

Electrical Transmission and Distribution Reference Book

*Copyright 1997
by ABB Power T&D Company Inc., Raleigh, North Carolina
Fifth Edition, Thirteenth Printing
Printed in the United States of America*

Electrical Transmission and Distribution Reference Book

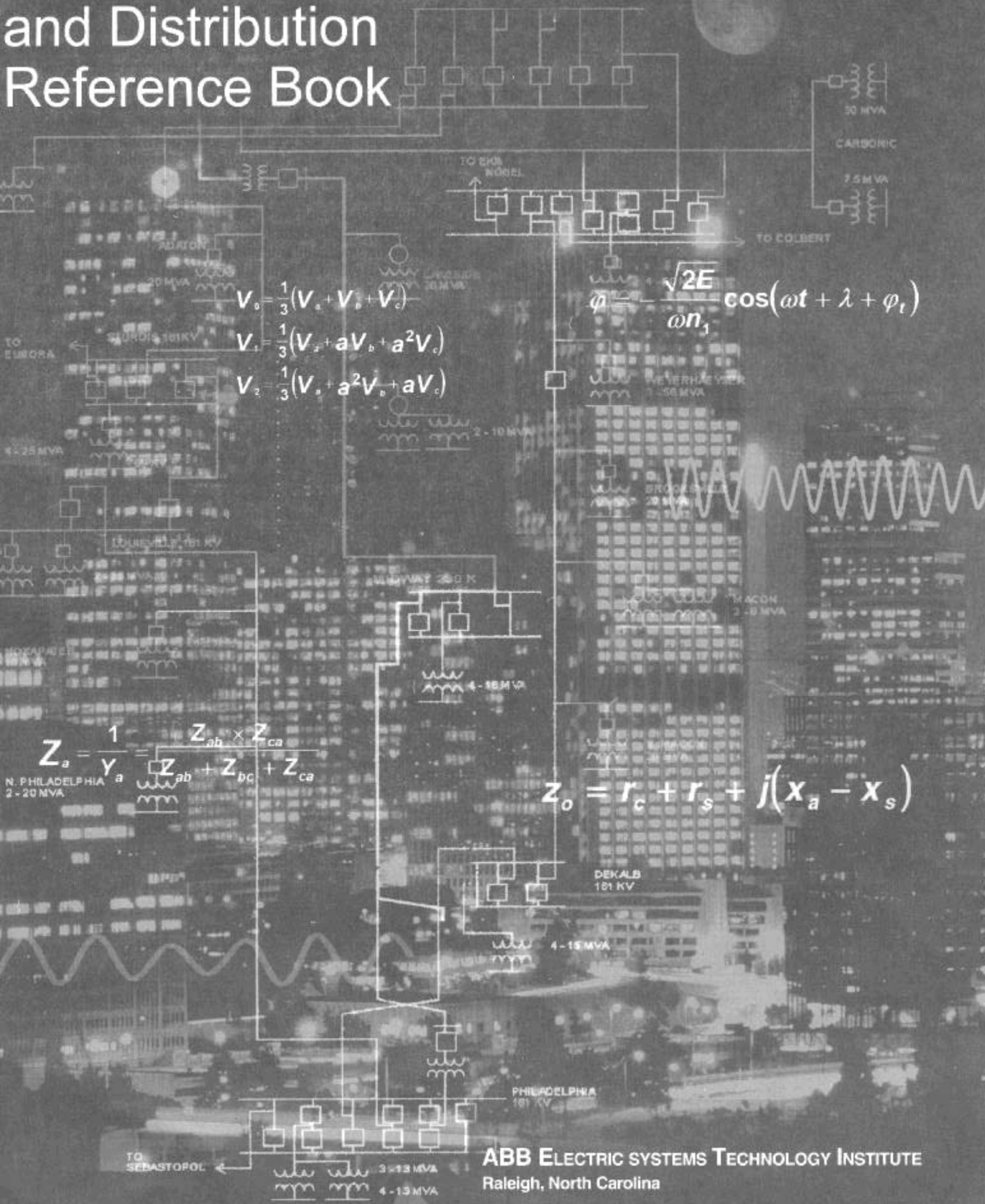

$$V_o = \frac{1}{3}(V_a + V_b + V_c)$$

$$V_1 = \frac{1}{3}(V_a + aV_b + a^2V_c)$$

$$V_2 = \frac{1}{3}(V_a + a^2V_b + aV_c)$$

$$\phi = \frac{\sqrt{2E}}{\omega n_1} \cos(\omega t + \lambda + \phi_t)$$

$$Z_a = \frac{1}{Y_a} = \frac{Z_{ab} \times Z_{ca}}{Z_{ab} + Z_{bc} + Z_{ca}}$$

$$Z_o = r_c + r_s + j(x_a - x_s)$$

ABB ELECTRIC SYSTEMS TECHNOLOGY INSTITUTE
Raleigh, North Carolina

Preface to the fifth edition

Fifty-five years ago, the Central Station Engineering Group of Westinghouse Electric Company first published a book focused on the practical application of electrical engineering to the transportation and delivery of electric power. The *Electrical Transmission and Distribution Reference Book* proved to be a simple, practical, and useful reference book for electric utility engineers as well as electrical equipment designers. Three generations of power engineers have used what has become popularly known as the “T&D Book” both as a core technical reference and as a tutorial on the finer points of power delivery system design and operation.

In the five and one half decades between its original publication and this latest edition, the T&D Book was revised and expanded three times. In many ways, the T&D book’s growth and evolution mirrored that of the electric power industry itself. The original book focused almost exclusively on transmission systems, addressing the higher voltages and longer lines then becoming common, as well as the rapidly growing complexity of transmission systems, particularly due to interconnection of individual electric utility systems into large power grids.

The long-term trend, however, was toward an increasing focus on distribution, that portion of the T&D system nearest the customer. Subsequent revisions of the T&D book added sections on power distribution systems, primary and secondary network design, capacitor application, and voltage flicker.

This latest revision continues the trend of increasing attention to the levels of the T&D system nearest the customer. Chapter 24, Characteristics of Distribution Loads, focuses on consumer load requirements and how they interact with distribution system economy and reliability. It presents detailed guidelines and design methods to identify the behavior of electric load on the distribution system, and to address it with respect to the “two Qs” – quantity and quality – that consumers of electric power have come to expect the T&D system will provide.

A more recent and accelerating trend in the power industry is the growth through mergers and acquisitions of both power companies and equipment suppliers into international companies operating on a worldwide scale. Several enormous power companies operate large power grids on three or more continents. More directly associated with this book, what was once the Central Station Engineering Group of Westinghouse Electric Company has been absorbed into ABB ELECTRIC SYSTEMS TECHNOLOGY INSTITUTE, part of a global company with technical and business resources vastly beyond anything the original authors of the T&D book could have envisioned. ABB-ETI continues to maintain the traditional, practical focus of the T&D book's creators, but has added research and development activities focused on meeting the needs of the 21st century with new equipment, designs, and technology.

This latest revision does more than just talk about new technologies. *Electrical Transmission and Distribution Reference Book*, fifth edition, is available in the traditional printed format as well as on computerized CD-ROM. The new format expands the book's usefulness as a resource for modern power engineers.

The material presented here is the result of research, investigation and practical application by many engineers and scientists, including cooperative studies with electric utilities, conductor and cable manufacturers, communications companies and industrial power users. It is not feasible to list here all of the names of the companies and individuals who have contributed to the body of knowledge covered in this book. These acknowledgements are given in the individual chapters. The authors gratefully acknowledge the hearty cooperation of all those who worked to produce this book. In particular, we wish to thank Ms. Kathy Hendricks, who tirelessly assisted in the preparation, editing, and formatting of this fifth edition.

Enrique Santacana
Vice-President and Director

October 1, 1997

Contents

Original Author ■ and Revising Author

CHAPTER 1	General Considerations of Transmission	page 1
	<i>C. A. Powel ■ C. A. Powel</i>	
2	Symmetrical Components	page 12
	<i>J. E. Hobson ■ D. L. Whitehead</i>	
3	Characteristics of Aerial Lines	page 32
	<i>Sherwin H. Wright and C. F. Hall ■ D. F. Shankle and R. L. Tremaine</i>	
4	Electrical Characteristics of Cables	page 64
	<i>H. N. Muller, Jr. ■ J. S. Williams</i>	
5	Power Transformers and Reactors	page 96
	<i>J. E. Hobson and R. L. Witzke ■ R. L. Witzke and J. S. Williams</i>	
6	Machine Characteristics	page 145
	<i>C. F. Wagner ■ C. F. Wagner</i>	
7	Excitation Systems	page 195
	<i>J. E. Barkle, Jr.</i>	
8	Application of Capacitors to Power Systems	page 233
	<i>A. A. Johnson</i>	
9	Regulation and Losses of Transmission Lines	page 265
	<i>G. D. McCann ■ R. F. Lawrence</i>	
10	Steady-State Performance of Systems Including Methods of Network Solution	page 290
	<i>E. L. Harder ■ E. L. Harder</i>	
11	Relay and Circuit Breaker Application	page 342
	<i>E. L. Harder and J. C. Cunningham ■ E. L. Harder and J. C. Cunningham</i>	
12	Power-Line Carrier Application	page 401
	<i>R. C. Cheek</i>	
13	Power-System Stability—Basic Elements of Theory and Application	page 433
	<i>R. D. Evans and H. N. Muller, Jr. ■ J. E. Barkle, Jr. and R. L. Tremaine</i>	
14	Power-System Voltages and Currents During Abnormal Conditions	page 496
	<i>R. L. Witzke ■ R. L. Witzke</i>	

Original Author ■ and Revising Author

CHAPTER 15	Wave Propagation on Transmission Lines	page 523
	<i>C. F. Wagner and G. D. McCann ■ C. F. Wagner</i>	
16	Lightning Phenomena	page 542
	<i>C. F. Wagner and G. D. McCann ■ C. F. Wagner and J. M. Clayton</i>	
17	Line Design Based on Direct Strokes	page 578
	<i>A. C. Monteith ■ E. L. Harder and J. M. Clayton</i>	
18	Insulation Coordination	page 610
	<i>A. C. Monteith and H. R. Vaughan ■ A. A. Johnson</i>	
19	Grounding of Power-System Neutrals	page 643
	<i>S. B. Griscom ■ S. B. Griscom</i>	
20	Distribution Systems	page 666
	<i>John S. Parsons and H. G. Barnett ■ John S. Parsons and H. G. Barnett</i>	
21	Primary and Secondary Network Distribution Systems	page 689
	<i>John S. Parsons and H. G. Barnett ■ John S. Parsons and H. G. Barnett</i>	
22	Lamp Flicker on Power Systems	page 719
	<i>S. B. Griscom ■ S. B. Griscom</i>	
23	Coordination of Power and Communication Systems	page 741
	<i>R. D. Evans ■ R. L. Witzke</i>	
24	Characteristics of Distribution Loads	page 784
	<i>H. L. Willis</i>	
	Appendix	page 809
	Index	page 838

CHAPTER 1

GENERAL CONSIDERATIONS OF TRANSMISSION

Original Author:
C. A. Powel

Revised by:
C. A. Powel

THROUGH discovery, invention, and engineering application, the engineer has made electricity of continually greater use to mankind. The invention of the dynamo first made engine power many times more effective in relieving the toil and increasing the opportunities and comforts not only of industry but also of the home. Its scope, however, was limited to relatively short distances from the power station because of the low voltage of the distribution circuits. This limitation, for economic reasons, kept the general use of electricity confined to city areas where a number of customers could be served from the same power station. The next step in the development of the present-day electric systems was the invention of the transformer. This invention was revolutionary in its effect on the electric industry because it made high voltage and long transmission distances possible, thus placing the engine power, through the medium of the alternating-current generator, at the doorstep of practically everyone.

The first alternating current system in America using transformers was put in operation at Great Barrington in Massachusetts in 1886. Mr. William Stanley, Westinghouse electrical expert who was responsible for the installation, gives an account of the plant, part of which reads:

"Before leaving Pittsburgh I designed several induction coils, or transformers as we now call them, for parallel connection. The original was designed in the early summer of 1885 and wound for 500 volts primary and 100 volts secondary emf. Several other coils were constructed for experimental purposes.

"At the north end of the village of Great Barrington was an old deserted rubber mill which I leased for a trifling sum and erected in it a 25 hp boiler and engine that I purchased for the purpose. After what seemed an interminable delay I at last installed the Siemens alternator that Mr. Westinghouse had imported from London. It was wound to furnish 12 amperes of current with a maximum of 500 volts. In the meantime I had started the construction of a number of transformers in the laboratory and engaged a young man to canvass the town of Great Barrington for light customers. We built in all at Great Barrington 26 transformers, 10 of which were sent to Pittsburgh to be used in a demonstration plant between the Union Switch and Signal Company's factory* and East Liberty.

"We installed in the town plant at Great Barrington two 50-light and four 25-light transformers, the remainder being used in the laboratory for experimental work. The transformers in the village lit 13 stores, 2 hotels, 2 doctors' offices, one barber shop, and the telephone and post offices. The length of the line from the laboratory to the center of the town was about 4000 feet."

Our central-station industry today is, for all practical purposes, entirely alternating current. It can, therefore, be said to have grown from the small beginning at Great

*About two miles.

Barrington to its present size involving as it does a capitalization in the privately-owned power companies of some 17 billion dollars with an annual revenue of 4 billion dollars.

The growth since the beginning of this century in installed generating capacity of all electric power plants

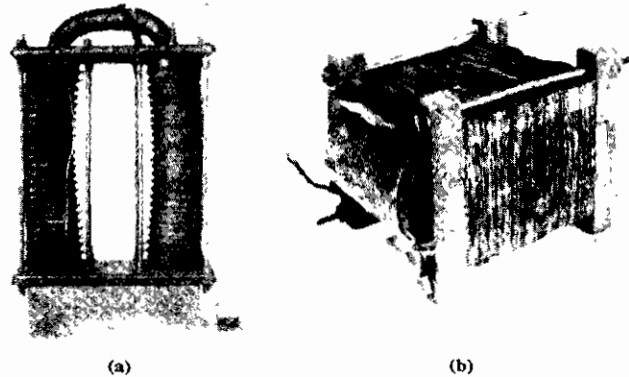

Fig. 1—(a) Gaulard and Gibbs transformer for which George Westinghouse had secured all rights in the United States. (b) First transformer designed by William Stanley. The prototype of all transformers since built, it definitely established the commercial feasibility of the alternating-current system, 1884-1886.

contributing to the public supply has been from about $1\frac{1}{2}$ million kilowatts to 55 million kilowatts in 1948. Of this 55 million kilowatts the privately-owned utilities accounted for 44 million kilowatts and government-owned utilities for 11 million kilowatts divided equally between the federal government and local governments. Thus, 80 percent of the generating capacity of the country is privately owned and 20 per cent government owned.

With this 55 million kilowatts of generating capacity, 282 billion kilowatt-hours, divided 228 billion kilowatt-hours by privately-owned generation and 54 billion public, were generated in 1948. The average use of the installed capacity for the country as a whole was, therefore,

$\frac{282\ 000}{55} = 5130$ hours, and the capacity factor for the country as a whole $\frac{5130}{8760} = 58.5$ percent.

This capacity factor of 58.5 percent is generally conceded as being too high. It does not allow sufficient margin to provide adequate spare capacity for maintenance and repairs. Fig. 2 illustrates how the spare and reserve capacity has shrunk in the past few years. A ratio of installed capacity to peak load of 1.15 to 1.20 is considered necessary to provide a safe margin for emergencies. Such

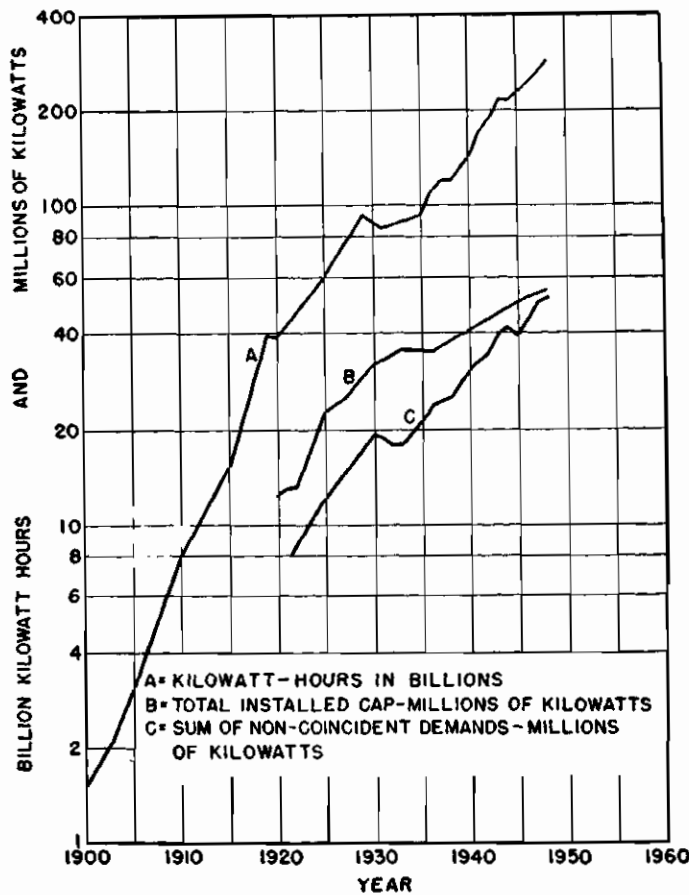

Fig. 2—Trend in production of electricity, installed capacity, and sum of peak demands.

a margin in 1948 would have given a capacity-factor of about 53 percent, instead of 58.5 percent.

The average cost of all electricity used for residential service has shown a steady downward trend since 1925 from 7 cents per kilowatt-hour to 3 cents in 1948. This is all the more remarkable as since 1939 all other items making up the cost-of-living index have shown increases ranging from 10 percent (for rents) to 121 percent (for food), the average increase of all items being 69 percent. The revenue from sales to residential customers accounts for about 36 percent of the total utility revenue; to large power customers about 29 percent; to small light and power customers 27 percent, and to miscellaneous customers (railroads, street lighting, etc.) 8 percent.

1. Sources of Energy

The sources of energy for large-scale generation of electricity are:

1. Steam, from (a) coal, (b) oil, or (c) natural gas
2. Water (hydro-electric)
3. Diesel power from oil

Other possible sources of energy are direct solar heat, windpower, tidal power, shale oil, and atomic energy, but none of these as yet has gone beyond the pilot-plant stage, for the reason that coal and petroleum are still abundantly available. But as fossil fuels become scarcer and more expensive, there is every reason to believe that all of these, as well as petroleum manufactured from vegetable matter, may become useful and economical supplementary sources of energy.

The estimated reserves of coal and lignite in the United States are about 3000 billion tons. This constitutes almost 99 percent of the mineral fuel energy reserves of the country; oil shale, petroleum and natural gas amounting to little more than 1 percent.¹

By far the greater part of the electric energy generated in this country is obtained from fuel, the 55 million kilo-

TABLE 1—PREFERRED STANDARDS FOR LARGE 3600-RPM 3-PHASE 60-CYCLE CONDENSING STEAM TURBINE-GENERATORS

	Air-Cooled Generator	Hydrogen-Cooled Generators Rated for 0.5 Psig Hydrogen Pressure						
		11 500	15 000	20 000	30 000	40 000	60 000	90 000*
Turbine-generator rating, kw	11 500	15 000	20 000	30 000	40 000	60 000	90 000*	
Turbine capability, kw	12 650	16 500	22 000	33 000	44 000	66 000	99 000	
Generator rating, kva	13 529	17 647	23 529	35 294	47 058	70 588	105 882	
power factor	0.85	0.85	0.85	0.85	0.85	0.85	0.85	
short-circuit ratio	0.8	0.8	0.8	0.8	0.8	0.8	0.8	
Throttle pressure, psig	600	850	850	850	{850} or {1250}	{850} or {1250}	{1450} or {1450}**	
Throttle temperature, F	825	900	900	900	{900} {950}	{900} {950}	{1000} {1000}	
Reheat temperature, F	1000	
Number of extraction openings	4	4	4	5	5	5	5	
Saturation temperatures at								
openings at "turbine-generator rating" with all extraction openings in service, F	1st	175	175	175	175	175	180	
	2nd	235	235	235	235	235	245	
	3rd	285	285	285	285	285	305	
	4th	350	350	350	350	350	380	
	5th	410	410	440	
Exhaust pressure, inches Hg abs	1.5	1.5	1.5	1.5	1.5	1.5	1.5	
Generator capability at 0.85 power factor and 15 psig hydrogen pressure, kva	...	20 394	27 058	40 588	54 117	81 176	121 764	
Generator capability at 0.85 power factor and 30 psig hydrogen pressure, kva	132 353	

*A 10 percent pressure drop is assumed between the high pressure turbine exhaust and low pressure turbine inlet for the reheat machine.

**These are two different units; the first for regenerative cycle operation, and the second a machine for reheat cycle operation.

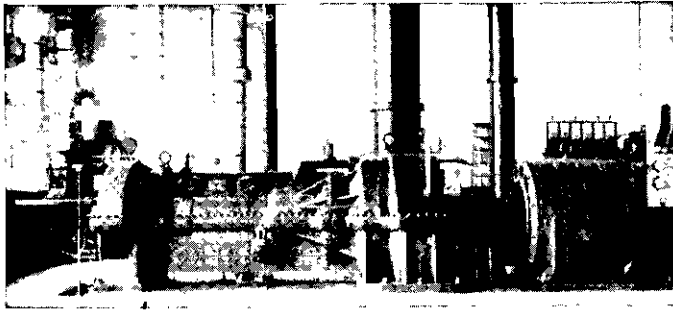

Fig. 3—The first central-station turbo-alternator installation in the United States—a 2000-kw turbine coupled to a 60-cycle generator, 2000 kw, 2400 volts, two-phase, 1200 rpm—at the Hartford Electric Light Company, Hartford, Connecticut, 1900. This turbine was about four times as large as any one built before that time and caused much comment the world over.

watts of installed capacity being made up of approximately 38 million kilowatts of steam turbines and one million kilowatts of diesel engines. Approximately 16 million kilowatts of the installed capacity are in hydro-electric stations. Of the 282 billion kilowatt-hours generated by all means in 1948, roughly 200 billion came from fuel; 76 percent from coal, 14 percent from natural gas, and 10 percent from oil.

2. Development of Steam Power

The modern steam-electric station can be dated from the installation by the Hartford Electric Company in 1900 of a 2000-kw unit (Fig. 3) which at that time was a large machine. Progress in design and efficiency from then on has been continuous and rapid. In 1925 the public utilities consumed in their fuel-burning plants an average of 2 pounds of coal (or coal equivalent) per kilowatt-hour, whereas today the corresponding figure is 1.3 pounds per kilowatt-hour. This average figure has not changed materially in the last 10 years. It would appear that the coal consumption curve is approaching an asymptote and that a much better overall performance is not to be expected, even though the best base-load stations generate power for less than one pound of coal per kilowatt-hour. The very high efficiency in the best base-load stations is obtained at a considerable increase in investment. It cannot be economically carried over to the system as a whole for the reason that there must be some idle or partly idle capacity on the system to allow for peaks (seasonal and daily), cleaning, adjustments, overhaul, and repairs. How much one can afford to spend for the improvement of station efficiency above "normal" depends on the shape of the system load curve, the role of the station in that curve, and the cost of fuel.

Most of the credit for the improvement in steam consumption goes to the boiler and turbine manufacturers who through continuous betterment of designs and materials have been able to raise steam pressures and temperatures. Between 1925 and 1942 the maximum throttle pressure was raised from 1000 psi to 2400 psi and the average from 350 to 1000 psi. In the same period the throttle temperature was raised from 725 to 1000 degrees F. and the

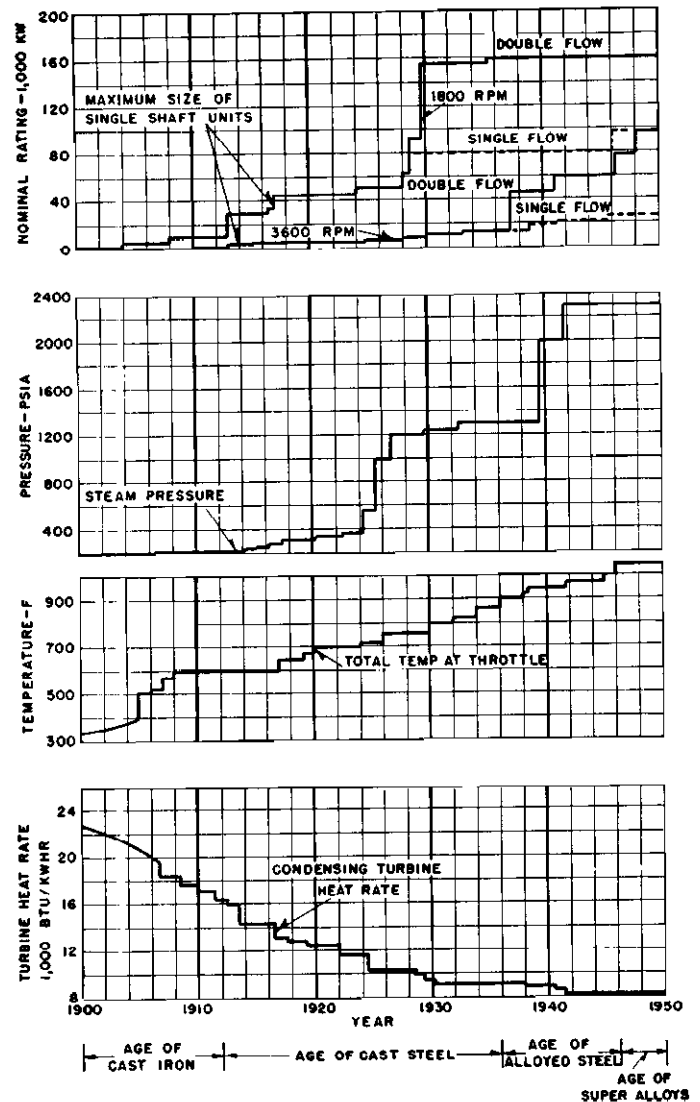

Fig. 4—Progress in turbine generator design.

average from 675 to 910 degrees. Generator losses in the meantime have been greatly reduced from about 6 percent in 1900 to 2 percent today, but these losses never did form a large part of the total, and their influence on the overall performance of the station has been minor.

The increase in maximum size of 60-cycle, two- and four-pole generating units over the years since 1900 is shown in Fig. 4. The remarkable increase has been due to improved materials and designs, particularly in large forgings, turbine blading, and generator ventilation.

In 1945 the American Society of Mechanical Engineers and the American Institute of Electrical Engineers adopted standard ratings for turbine-generator units. These were revised in November 1950 to include the 90 000 kw unit and are listed in Table 1. The machines are designed to meet their rating with 0.5 psi hydrogen pressure, but experience has shown that between 0.5 and 15 psi the output of the generator can be increased one percent for each pound increase in the gas pressure without exceeding the temperature rise guarantee at atmospheric pressure. In many locations operation at more than 15 psi gas pressure

may be difficult because of codes regulating operation of "unfired pressure vessels" at greater pressures, but serious consideration is being given to operation at 30 lbs.

For a hydrogen-air mixture to be explosive, the percentage of hydrogen must lie between 5 and 75 percent. The control equipment is designed to operate an alarm if the purity of the hydrogen drops below 95 percent. The density meter and alarm system is in principle a small constant-speed fan circulating a sample of the mixture. If the density varies, the drop of pressure across the fan varies and registers on the meter.

3. Development of Water Power

The great transmission systems of this country received their impetus as a result of hydro-electric developments. Forty years ago conditions favored such developments, and in the early years of this century water-power plants costing \$150 per kilowatt or less were common. Steam stations were relatively high in first cost and coal consumption per kilowatt hour was three times as much as today, and finally fuel oil was not readily available. As undeveloped water-power sites became economically less desirable, steam stations less costly and their efficiency higher, and as oil fuel and natural gas became more generally available through pipe lines, steam stations rapidly outgrew hydro-electric stations in number and capacity. Today very few water-power sites can be developed at such low cost as to be competitive with steam stations in economic energy production. For this reason hydro-electric developments of recent years have almost all been undertaken by Government agencies, which are in a position to include in the projects other considerations, such as, navigation, flood control, irrigation, conservation of resources, giving them great social value.

As the water-power developments within easy reach of the load centers were utilized and it became necessary to reach to greater distances for water power, only large developments could be considered, and stations of less than 100 000 kw became the exception rather than the rule, as witness Conowingo with 252 000 kw, Diablo with 135 000 kw, Fifteen Mile Falls with 140 000 kw, Osage with 200 000 kw, and many others. The developments of recent years undertaken by various government agencies have reached gigantic proportions, as for example Hoover Dam with 1 000 000 and Grand Coulee with 2 000 000 kw installed capacity.

A natural corollary to the increase in station capacity has been a gradual increase in the size of the individual generator units, the growth of which is shown in Fig. 5, culminating in the Grand Coulee generators of 120 000 kw at 120 rpm with an overall diameter of 45 feet.

Most of the multi-purpose hydraulic developments call for large, slow-speed machines. For such conditions vertical units are used to obtain maximum energy from the water passing through the turbine. The rotating parts are supported by a thrust bearing which is an integral part of the generator.

Two general types of generator design are used as distinguished by the arrangement of the guide and thrust bearings. Where the axial length of the generator is short in relation to its diameter, the "umbrella" design

is preferred, in which a single combination guide and thrust bearing is located below the rotor (Fig. 1, Chapter 6). Where the axial length of the machines is too great an additional guide bearing must be provided. In this case the combination thrust and guide bearing is usually located above the rotor and the additional guide bearing below the rotor.

The advantages of the umbrella design are (a) reduction in overhead room to assemble and dismantle the unit during erection and overhaul, and (b) simplicity of the single bearing from the standpoint of cooling and mini-

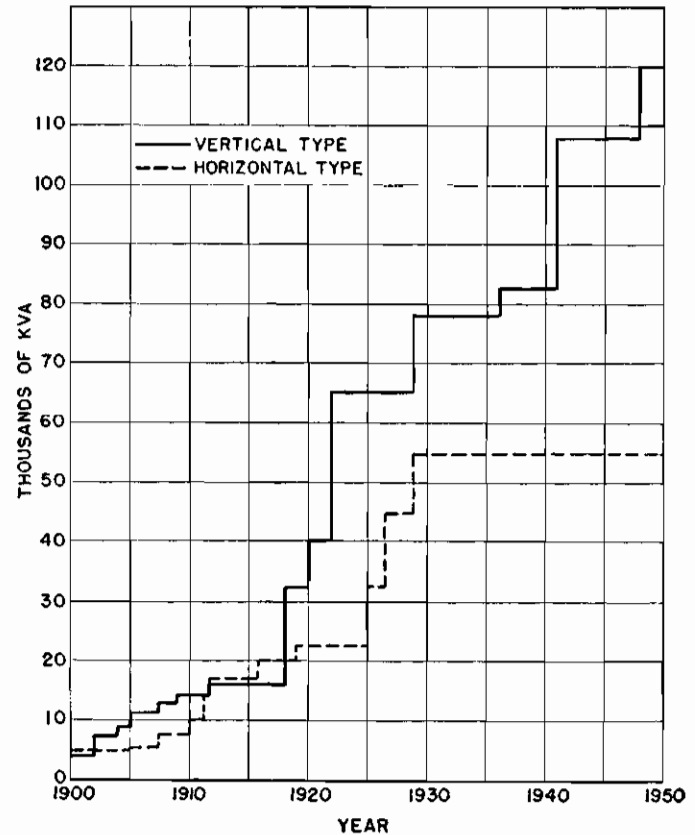

Fig. 5—Trend in maximum waterwheel generator ratings.

num amount of piping. The design also lends itself readily to a totally-enclosed recirculating system of ventilation, which keeps dirt out of the machine and facilitates the use of fire-extinguishing equipment. It also reduces heat and noise in the power house.

4. Combination of Water and Steam Power

There are very few locations today where an important market can be supplied entirely from water power because of seasonal variations in river flow, but in most cases a saving will be realized from combining water power and steam. The saving results from the combination of low operating cost of water-power plants with low investment cost of steam stations. Moreover, hydro-electric units in themselves have certain valuable advantages when used in combination with steam units. They start more quickly than steam-driven units, providing a high degree of standby readiness in emergency.

They are well adapted to maintenance of frequency, and also to providing wattless energy at times of low water flow. And finally, hydro-pondage can be drawn upon to relieve steam plants of short-time peaks to save banking extra boilers.

To what extent a water-power site can be developed economically involves a thorough investigation of individual cases. An economic balance must be struck between the steam and water power to give maximum economy. One might install enough generating capacity to take care of the maximum flow of the river during a short period. The cost per kilowatt installed would be low but the use made of the equipment (capacity factor) would also be low. Or one might put in only enough generating capacity to use the minimum river flow. In this case the cost of the development per kilowatt installed would be high, but the capacity factor would be high

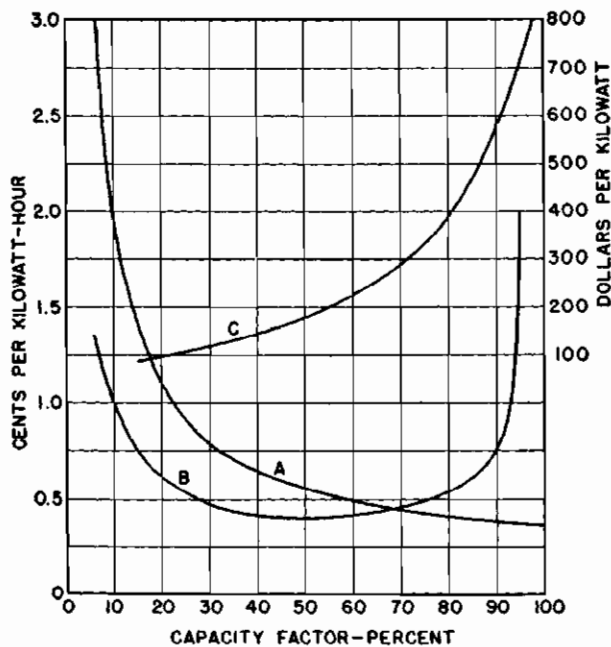

Fig. 6—Cost of energy at various capacity factors of steam and hydro-electric plants.

also. Obviously between these two extremes lies an optimum value. The ratio of installed water-power capacity to the peak load of the system that gives the minimum annual cost of power supply has been referred to as the "economic hydro ratio," and it can be determined without great difficulty for any particular set of conditions.

In a paper² presented before the American Society of Mechanical Engineers, Irwin and Justin discussed in an interesting and graphical manner the importance of incremental costs on the economics of any proposed development. Fig. 6, taken from their paper, shows in Curve C the capital cost per kilowatt of installation for various capacity factors. The costs were segregated in items that would be the same regardless of installation (land, water rights, dams) and those that vary with the amount of installation (power house, machinery, trans-

mission). The latter group in this particular study was about \$70 per kilowatt.

Curve A gives the total cost of energy per kilowatt hour for a modern steam plant costing \$95 per kilowatt with fixed charges at 12 percent and coal at \$4 a ton.

Curve B gives the total cost of energy from the water-power plant having the capital cost indicated in Curve C. To obtain such a curve it is necessary to determine the amount of energy available at the various capacity factors, the assumption being made that all hydro capacity installed is firm capacity[†], that is, that the system load can absorb all of the energy generated.

Curve B shows the typically high cost of hydro-electric energy as compared with steam at high capacity factors and its low cost at low capacity factors.

5. Transmission Liability

In a hydro-electric development the transmission becomes a large factor of expense and in comparing such developments with equivalent steam plants, it is necessary to include the transmission as a charge against the hydro-electric plant. Figures of cost published on the Hoover Dam-Los Angeles 287-kv line indicate that this transmission costs over \$90 a kilowatt, and other lines contemplated will probably show higher costs.

Under certain conditions it may be more costly to transmit electrical energy over wires than to transport the equivalent fuel to the steam station. It has been shown³ that the cost of electric transmission for optimum load and voltages can be expressed as a linear function of power and distance, as follows:

$$\text{For 50\% load factor: mills/kw-hr} = 0.54 + \frac{0.61 \times \text{miles}}{100}$$

$$\text{For 90\% load factor: mills/kw-hr} = 0.30 + \frac{0.35 \times \text{miles}}{100}$$

It was also shown that fuel transportation can be expressed as a linear function of energy and distance, thus:

Railroad rates on coal

$$\$1.20 + 5\frac{1}{2} \text{ mills per mile}$$

Pipe-line rates on crude oil

$$\$5.00 + 4 \text{ cents per mile per 100 barrels}$$

For pipe-line rates on natural gas two curves were given for estimated minimum and maximum interruptible contract rates

$$\$0 + 12 \text{ cents per mile per million cubic feet}$$

$$\$50 + 12 \text{ cents per mile per million cubic feet}$$

The authors point out that a comparison between transmission costs alone for gas, oil, and coal are likely to be misleading because there is a wide difference in the costs of the fuels at their source. There is also a considerable variation in the transportation costs above and below the average.

[†]"Firm Capacity" or "Firm Power" in the case of an individual station is the capacity intended to be always available even under emergency conditions. "Hydro Firm Capacity" in the case of combined steam and hydro is the part of the installed capacity that is capable of doing the same work on that part of the load curve to which it is assigned as could be performed by an alternative steam plant.

The equivalence between the fuels is given as:

1 ton of coal.....	25 000 000 BTU
1 barrel of oil.....	6 250 000 BTU
1000 cubic feet of gas.....	1 000 000 BTU

6. Purpose of Transmission

Transmission lines are essential for three purposes.

- To transmit power from a water-power site to a market. These may be very long and justified because of the subsidy aspect connected with the project.
- For bulk supply of power to load centers from outlying steam stations. These are likely to be relatively short.
- For interconnection purposes, that is, for transfer of energy from one system to another in case of emergency or in response to diversity in system peaks.

Frequent attempts have been made to set up definitions of "transmission lines," "distribution circuits" and "substations." None has proved entirely satisfactory or universally applicable, but for the purposes of accounting the Federal Power Commission and various state commissions have set up definitions that in essence read:

A transmission system includes all land, conversion structures and equipment at a primary source of supply; lines, switching and conversion stations between a generating or receiving point and the entrance to a distribution center or wholesale point, all lines and equipment whose primary purpose is to augment, integrate or tie together sources of power supply.

7. Choice of Frequency

The standard frequency in North America is 60 cycles per second. In most foreign countries it is 50 cycles. As a general-purpose distribution frequency 60 cycles has an economic advantage over 50 cycles in that it permits a maximum speed of 3600 rpm as against 3000 rpm. Where a large number of distribution transformers are used a considerable economic gain is obtained in that the saving in materials of 60-cycle transformers over 50-cycle transformers may amount to 10 to 15 percent. This is because in a transformer the induced voltage is proportional to the total flux-linkage and the frequency. The higher the frequency, therefore, the smaller the cross-sectional area of the core, and the smaller the core the shorter the length of the coils. There is a saving, therefore, in both iron and copper.

The only condition under which any frequency other than 50 to 60 cycles might be considered for a new project would be the case of a long transmission of, say, 500 or 600 miles. Such long transmission has been discussed in connection with remote hydro-electric developments at home and abroad, and for these a frequency less than 60 cycles might be interesting because as the frequency is decreased the inductive reactance of the line, $2\pi fL$, decreases and the capacitive reactance, $\frac{1}{2\pi fC}$, increases, resulting in higher load limits, transmission efficiency, and better regulation.

Full advantage of low frequency can be realized, however, only where the utilization is at low frequency. If the low transmission frequency must be converted to 60 cycles for utilization, most of the advantage is lost because of limitations of terminal conversion equipment.

Long-distance direct-current transmission has also been considered. It offers advantages that look attractive, but present limitations in conversion and inversion equipment make the prospect of any application in the near future unlikely.

In many industrial applications, particularly in the machine-tool industry, 60 cycles does not permit a high enough speed, and frequencies up to 2000 cycles may be necessary. Steps are being taken to standardize frequencies of more than 60 cycles.

8. Choice of Voltage

Transmission of alternating-current power over several miles dates from 1886 when a line was built at Cerchi, Italy, to transmit 150 hp 17 miles at 2000 volts. The voltage has progressively increased, as shown in Fig. 7, until in 1936 the Hoover Dam-Los Angeles line was put in service at 287 kv. This is still the highest operating voltage in use in the United States today, but consideration is being given to higher values. An investigation was begun in 1948 at the Tidd Station of the Ohio Power Company on an experimental line with voltages up to 500 kv.

The cost of transformers, switches, and circuit breakers increases rapidly with increasing voltage in the upper ranges of transmission voltages. In any investigation involving voltages above 230 000 volts, therefore, the unit cost of power transmitted is subject to the law of diminishing returns. Furthermore, the increase of the reactance of the terminal transformers also tends to counteract the gain obtained in the transmission line from the higher voltage. There is, therefore, some value of voltage in the range being investigated beyond which, under existing circumstances, it is uneconomical to go and it may be more profitable to give consideration to line compensation by means of capacitors to increase the economic limit of

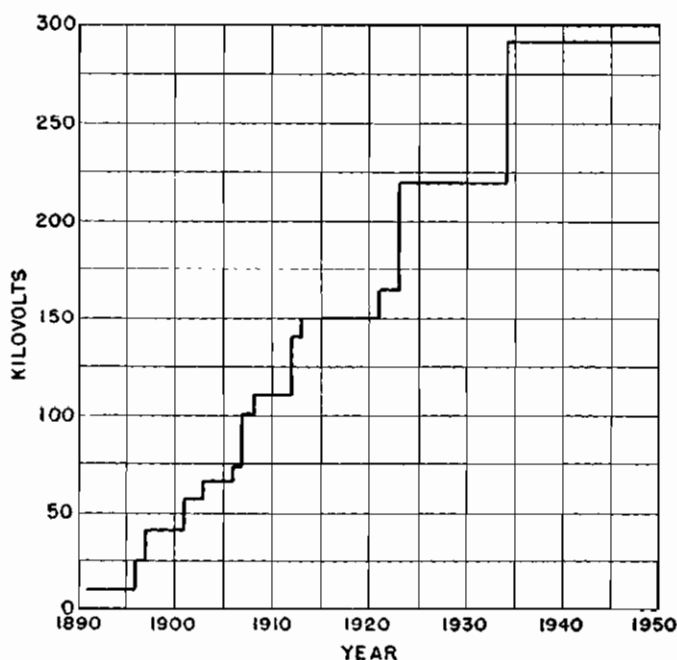

Fig. 7—Trend in transmission voltages in 60 years.

TABLE 2—FORM OF TABULATION FOR DETERMINING VOLTAGES AND CONDUCTOR SIZES

Based on the Transmission of 10 000 Kva for 10 Miles at 80 Percent Power Factor Lagging, 60-Cycle, 3-Phase

Between Conductors in KV	To Neutral in KV	Amperes for 10 000 Kva	CONDUCTORS										VOLTAGE DROP AT FULL LOAD			FIRST COST						ANNUAL OPERATING COST		
			B&S or Circular Mils	Total Weight in Pounds	Resistance in Ohms	Total I ² R Loss			Total Loss per Year in Kw-hr.	Resistance IR in Percent	Reactance IX in Percent	Percent Regulation	Conductors at 30 Cents per Pound	Transformers 25 000 Kva	Circuit Breakers and Contro	Lightning Arresters	Insulators	Total	Interest on First Cost at 6 Percent	Depreciation on First Cost 10 Percent	I ² R Losses at 1 Cent per Kw-hr.	Total		
						10 000 Kva	2 500 Kva	Loss in Percent																
22	12.7	262	300 000	147 000	1.97	405	5.1	25	1 610 000	4.1	12.6	11.0	\$14 100	\$69 600	\$ 9 500	\$1 600	\$1 500	\$126 300	\$7 580	\$12 630	\$16 100	\$36 310		
			#000	82 100	3.50	720	9.0	45	2 860 000	7.2	13.4	14.0	24 600	69 600	9 500	1 600	1 500	106 800	6 410	10 680	28 600	45 690		
			#0	51 600	5.55	1 140	14.3	71	4 520 000	11.5	14.0	17.5	15 500	69 600	9 500	1 600	1 500	97 700	5 860	9 770	45 200	60 830		
33	19.1	175	#00	65 000	4.40	405	5.1	25	1 610 000	4.0	6.4	7.0	19 500	71 600	9 700	2 400	2 200	105 400	6 330	10 540	16 100	32 970		
			#2	32 500	8.82	810	10.1	51	3 220 000	8.1	6.8	10.5	9 700	71 600	9 700	2 400	2 200	95 600	5 740	9 560	32 200	47 500		
			#4	20 200	14.0	1 290	16.1	81	5 120 000	12.9	7.0	14.5	6 000	71 600	9 700	2 400	2 200	91 900	5 520	9 190	51 200	65 910		
44	25.4	131	#2	32 500	8.82	453	5.7	28	1 800 000	4.5	3.8	5.9	9 700	74 400	10 900	3 400	3 000	101 400	6 090	10 140	18 000	34 230		
			#5	16 000	17.7	910	11.4	57	3 610 000	9.1	4.0	9.7	4 800	74 400	10 900	3 400	3 000	96 500	5 790	9 650	36 100	51 540		

TABLE 3—QUICK-ESTIMATING DATA ON THE LOAD CARRYING CAPACITY OF TRANSMISSION LINES†

Delivered Line Voltage	Kw Which Can Be Delivered Based on 5% Regulation and 90% Power Factor				
	Distance in Miles				
13.2 kv—3-foot spacing Stranded Copper	5	10	15	20	
	4	950	490	330	245
	2	1 400	700	470	350
	4/0	3 000	1 500	1 000	750
33 kv—4-foot spacing Stranded Copper	10	20	30	40	
	1	5 000	2 500	1 700	1 250
	2/0	6 700	3 350	2 200	1 700
	4/0	8 350	4 180	2 800	2 100
300 000	11 500	5 750	3 800	2 900	
66 kv—8-foot spacing Stranded Copper	20	40	60	80	
	2/0	12 500	6 250	4 180	3 140
	4/0	16 000	8 000	5 320	3 990
	300 000	18 400	9 180	6 120	4 590
	Kw Which Can Be Delivered Based on 10% Loss and Equal Voltage at Sending and Receiving Ends				
	Distance in Miles				
132 kv—16-foot spacing Stranded Copper	40	80	120	160	
	4/0	116 000	58 000	39 500	30 100
	300 000	172 000	86 000	58 800	44 800
	500 000	297 000	150 000	101 000	77 100
220 kv—24-foot spacing Hollow Copper	80	160	240	320	
	500 000	425 000	219 000	151 000	119 000
ACSR—795 000	417 000	216 000	149 000	118 500	

†Data obtained from Figs. 19 and 22 of Chap. 9.

power transmission than increase the voltage much above present practice.

The basic principles underlying system operation as regards voltages have been set forth in a report⁴ which lists the voltages in common use, the recommended limits of voltage spread, and the equipment voltage ratings intended to fulfill the voltage requirements of the level for which the equipment is designed. The report should be carefully studied before any plans are made involving the adoption of or change in a system voltage.

In selecting the transmission voltage, consideration should be given to the present and probable future voltage of other lines in the vicinity. The advantages of being able to tie together adjoining power districts at a common voltage frequently outweighs a choice of voltage based on lowest immediate cost.

If the contemplated transmission is remote from any existing system, the choice of voltage should result from a complete study of all factors involved. Attempts have been made to determine by mathematical expression, based on the well-known Kelvin's Law, the most economical transmission voltage with all factors evaluated, but these are so numerous that such an expression becomes complicated, difficult, and unsatisfactory. The only satisfactory way to determine the voltage is to make a complete study of the initial and operating costs corresponding to various assumed transmission voltages and to various sizes of conductors.

For the purposes of the complete study, it is usually unnecessary to choose more than three voltages, because a fairly good guess as to the probable one is possible without knowing more than the length of the circuit. For this preliminary guess, the quick-estimating Table 3 is useful. This table assumes that the magnitude of power transmitted in the case of voltages 13.2, 33, and 66 kv is based on a regulation of 5 percent and a load power factor of 90 percent. In the case of 132 and 220 kv, the table is based on a loss of 10 percent and equal voltages at the sending and receiving ends of the line. The reason for this and the bases of the calculations are given in Chapter 9.

A representative study is given in Table 2. It is assumed

that it is desired to transmit over a single-circuit ten miles long 8000 kw (10 000 kva) at 80 percent power-factor lagging for 10 hours a day followed by 2000 kw (2500 kva) at 80 percent power-factor for 14 hours. The preliminary guess indicates that 23, 34.5, or 46 kv are probably the economical nominal voltages. Equivalent conductor spacing and the number of insulators are as given in Table 4. Conductors of hard-drawn stranded copper are

TABLE 4—CONSTRUCTION FEATURES OF TRANSMISSION LINES IN THE UNITED STATES*

Line Voltage in Kv	Length in Miles			Equivalent Spacing		Number of Insulators		
	Av.	Min.	Max.	Type**	Av.	Av.	Min.	Max.
13.8	SC-W	3
34.5	SC-W	4
69	35	25	100	SC-W	8	5	4	8
115	40	25	100	SC-W	17	7	6	11
138	40	25	140	SC-W	18	10	8	12
230	133	45	260	SC-ST	31	15	14	20

employed, the resistance being taken at 25 degrees C. The step-up and step-down transformers are assumed as $2.5 \times 10\,000$ kva, 12 500 kva at either end, and high-voltage circuit-breakers are used in anticipation of future additional circuits.

The costs of the pole line, right-of-way, building, and real estate are not included as they will be practically the same for the range of voltages studied.

Assuming that the cost figures in the table are correct, a 34 500-volt line with No. 00 copper conductor is the most economical. The transmission loss will be 5 percent and the regulation 7 percent at full load, which is deemed satisfactory. The voltage is sufficiently high for use as a subtransmission voltage if and when the territory develops and additional load is created. The likelihood of early growth of a load district is an important factor in selection of the higher voltage and larger conductor where the annual operating costs do not vary too widely.

9. Choice of Conductors

The preliminary choice of the conductor size can also be limited to two or three, although the method of selecting will differ with the length of transmission and the choice of voltage. In the lower voltages up to, say, 30 kv, for a given percentage energy loss in transmission, the cross section and consequently the weight of the conductors required to transmit a given block of power varies inversely as the square of the voltage. Thus, if the voltage is doubled, the weight of the conductors will be reduced to one-fourth with approximately a corresponding reduction in their cost. This saving in conducting material for a given energy loss in transmission becomes less as the higher voltages are reached, becoming increasingly less as voltages go higher. This is for the reason that for the higher voltages at least two other sources of

*This table is based on information published in *Electrical World* and in *Electrical Engineering*. While it does not include all lines, it is probably representative of general practice in the U.S.A.

**SC-W—Single-circuit wood.

SC-ST—Single-circuit steel.

loss, leakage over insulators and the escape of energy through the air between the conductors (known as "corona"—see Chap. 3) appear. In addition to these two losses, the charging current, which increases as the transmission voltage goes higher, may either increase or decrease the current in the circuit depending upon the power-factor of the load current and the relative amount of the leading and lagging components of the current in the circuit. Any change in the current of the circuit will consequently be accompanied by a corresponding change in the I^2R loss. In fact, these sources of additional losses may, in some cases of long circuits or extensive systems, materially contribute toward limiting the transmission voltage. The weight of copper conductors, from which their cost can be calculated, is given in Chap. 3. As an insurance against breakdown, important lines frequently are built with circuits in duplicate. In such cases the cost of conductors for two circuits should not be overlooked.

10. Choice of Spacing

Conductor spacing depends upon the economic consideration given to performance against lightning surges. If maximum reliability is sought, the spacing loses its relation to the operating voltage and then a medium voltage line assumes most of the cost of a high-voltage transmission without the corresponding economy. (See Chap. 17) In general a compromise is adopted whereby the spacing is based on the dynamic voltage conditions with some allowance for reasonable performance against lightning surges.

Table 4 shows typical features of transmission lines in the United States including their "equivalent spacing" and the number of suspension insulators used. By equivalent spacing is understood the spacing that would give the same reactance and capacitance as if an equilateral triangular arrangement of conductors had been used. It is usually impractical to use an equilateral triangular arrangement for design reasons. The equivalent spacing is obtained from the formula $D = \sqrt[3]{ABC}$ where A , B , and C are the actual distances between conductors.

11. Choice of Supply Circuits

The choice of the electrical layout of the proposed power station is based on the conditions prevailing locally. It should take into consideration the character of the load and the necessity for maintaining continuity of service. It should be as simple in arrangement as practicable to secure the desired flexibility in operation and to provide the proper facilities for inspection of the apparatus.

A review of existing installations shows that the apparent combinations are innumerable, but an analysis indicates that in general they are combinations of a limited number of fundamental schemes. The arrangements vary from the simplest single-circuit layout to the involved duplicate systems installed for metropolitan service where the importance of maintaining continuity of service justifies a high capital expenditure.

The scheme selected for stations distributing power at bus voltage differs radically from the layout that would be desirable for a station designed for bulk transmission.

In some metropolitan developments supplying underground cable systems segregated-phase layouts have been and are still employed to secure the maximum of reliability in operation. However, their use seems to be on the decline, as the improvement in performance over the conventional adjacent phase grouping is not sufficiently better to justify the extra cost, particularly in view of the continuing improvement of protective equipment and the more reliable schemes of relaying available today for removing faulty equipment, buses, or circuits.

Several fundamental schemes for bus layouts supplying feeders at generator voltage are shown in Fig. 8. These vary from the simplest form of supply for a small industrial plant as shown in (a) to a reliable type of layout for central-station supply to important load areas shown in (e) and (f)†.

Sketch (a) shows several feeders connected to a common bus fed by only one generator. This type of construction should be used only where interruptions to service are relatively unimportant because outages must exist to all feeders simultaneously when the bus, generator breaker, generator or power source is out of service for any reason. Each feeder has a circuit breaker and a disconnect switch. The circuit breaker provides protection against short circuits on the feeder and enables the feeder to be removed from service while it is carrying load if necessary. The disconnect switch serves as additional backup protection for personnel, with the breaker open, during maintenance or repair work on the feeder. The disconnect switch also enables the breaker to be isolated from the bus for inspection and maintenance on the breaker. Quite frequently disconnect switches are arranged so that when opened the blade can be connected to a grounded clip for protection. If the bus is supplied by more than one generator, the reliability of supply to the feeders using this type of layout is considerably increased.

With more than one generator complete flexibility is obtained by using duplicate bus and switching equipment as shown in (b). It is often questionable whether the expense of such an arrangement is justified and it should be used only where the importance of the service warrants it. One breaker from each generator or feeder can be removed from service for maintenance with complete protection for maintenance personnel and without disrupting service to any feeder. Also, one complete bus section can be removed from service for cleaning and maintenance or for adding an additional feeder without interfering with the normal supply to other feeder circuits. There are many intermediate schemes that can be utilized that give a lesser degree of flexibility, an example of which is shown in (c). There are also several connections differing in degree of duplication that are intermediate to the three layouts indicated, as for instance in (d). An analysis of the connections in any station layout usually shows that they are built up from parts of the fundamental schemes depending upon the flexibility and reliability required.

The generating capacity connected to a bus may be so

†NELA Publications Nos. 164 and 278-20—Elec. App. Comm. give a number of station and substation layouts.

large that it is necessary to use current-limiting reactors in series with the generator leads or in series with each feeder. Sometimes both are required. Sketch (e) shows a double bus commonly used where reactors are in series with each generator and each feeder. Bus-tie reactors are also shown that, with all generators in service, keep the short-circuit currents within the interrupting ability of the breakers. These bus-tie reactors are important

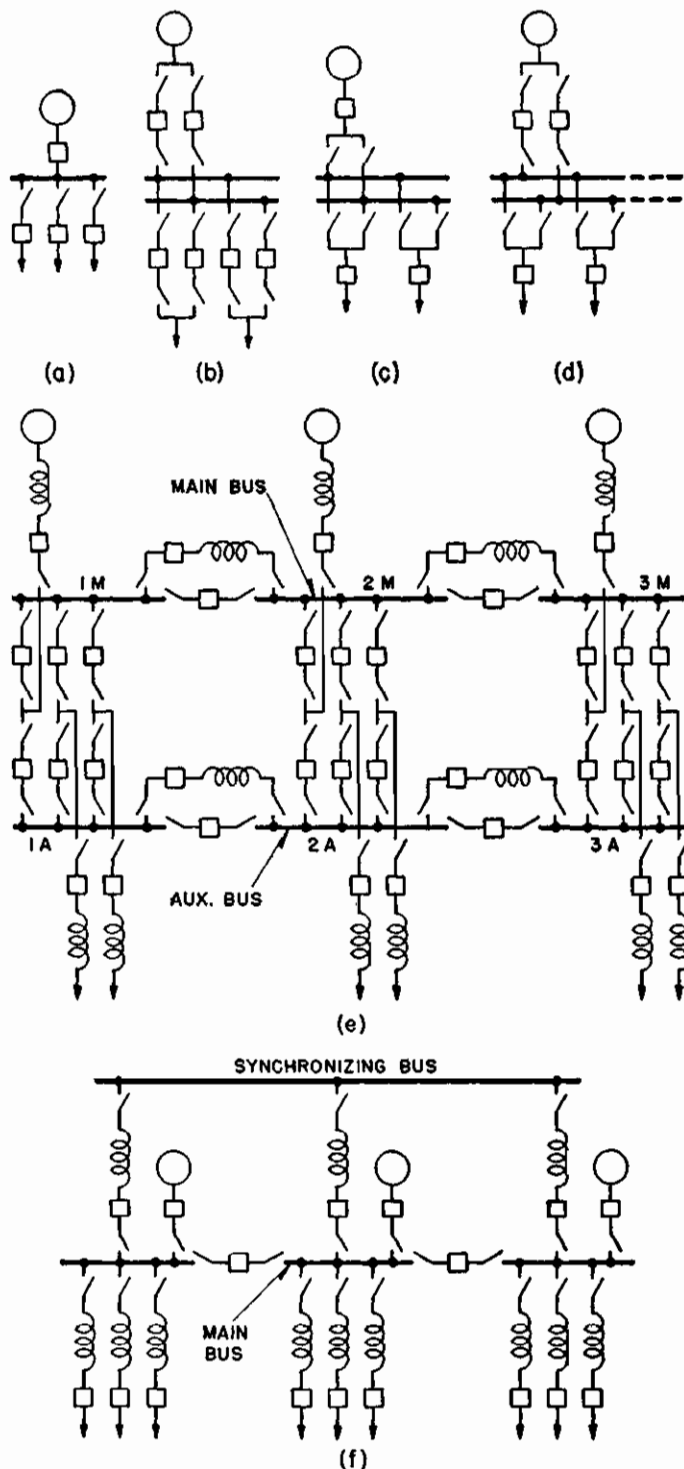

Fig. 8—Fundamental schemes of connections for supply at generator voltage.

because they not only limit the current on short circuit but also serve as a source of supply to the feeders on a bus section if the generator on that bus section fails. Each feeder can be connected to either the main or auxiliary bus through what is called a selector breaker. A selector breaker is similar in every respect to the feeder breaker and serves as backup protection in case the feeder breaker does not function properly when it should open on a feeder fault. The bus-tie breakers can be used when one or more generators are out of service to prevent voltage and phase-angle differences between bus sections that would exist with the supply to a bus section through a reactor. The phase angle between bus sections becomes important when a station is supplying a network system and should be kept to a minimum to prevent circulating currents through the network. For a network supply at least four bus sections are generally used so that the network can still be supplied in case one bus section should trip out on a fault. Sketch (e) shows only three bus sections, the main and auxiliary buses serve as one bus for the feeders connected to that section.

Sketch (f) shows a more modern design for central stations with the feeder reactors next to the bus structure, in contrast with (e) where the reactors are on the feeder side of the breaker. This arrangement is possible because of the proven reliability of reactors, circuit breakers, and dust-tight metalclad bus structures. Continuous supply to all feeders is provided through reactor ties to a synchronizing bus should a generator fail. Bus-tie circuit breakers are provided to tie solidly adjacent bus sections for operation with one or more generators out of service. Stations of this type would be expected to have four to six or more bus sections especially if the station supplies network loads. The synchronizing bus also serves as a point where tie feeders from other stations can be connected and be available for symmetrical power supply to all feeder buses through the reactors. This is not the case for station design shown in (e) where a tie feeder must be brought in to a particular bus section.

For any type of generating-station design proper current and potential transformers must be provided to supply the various types of relays to protect all electrical parts of the station against any type of fault. Likewise, current and voltage conditions must be obtained from current and potential transformers through the proper metering equipment to enable the operating forces to put into service or remove any equipment without impairing the operation of the remainder of the station. A ground bus must be provided for grounding each feeder when it is out of service for safety to personnel. Also a high-potential test bus is necessary to test circuit breakers, bus work and feeders, following an outage for repairs or maintenance, before being reconnected to the station.

Fire walls are generally provided between bus sections or between each group of two bus sections to provide against the possibility of a fire in one section spreading to the adjacent sections. The separate compartments within the station should be locked and made as tight as possible for protection against accidental contact by operating personnel either physically or through the medium of a wire or any conducting material. Stray animals have

caused considerable trouble by electrocuting themselves in accessible bus structures.

With stations supplying transmission systems the scheme of connections depends largely on the relative capacities of the individual generators, transformers and transmission circuits; and whether all the generated power is supplied in bulk over transmission lines or whether some must also be supplied at generator voltage. The simplest layout is obtained when each generator, transformer and transmission circuit is of the same capacity and can be treated as a single entity. Unfortunately, this is seldom the case because the number of generators do not equal the number of outgoing circuits. Even here, however, some simplification is possible if the transformers are selected of the same capacity as the generators, so that the combination becomes the equivalent of a high-voltage generator with all the switching on the high-voltage side of the transformer.

In Fig. 9, (a) shows the "unit scheme" of supply. The power system must be such that a whole unit comprising generator, transformer and transmission line can be dropped without loss of customer's load. The station auxiliaries that go with each unit are usually supplied

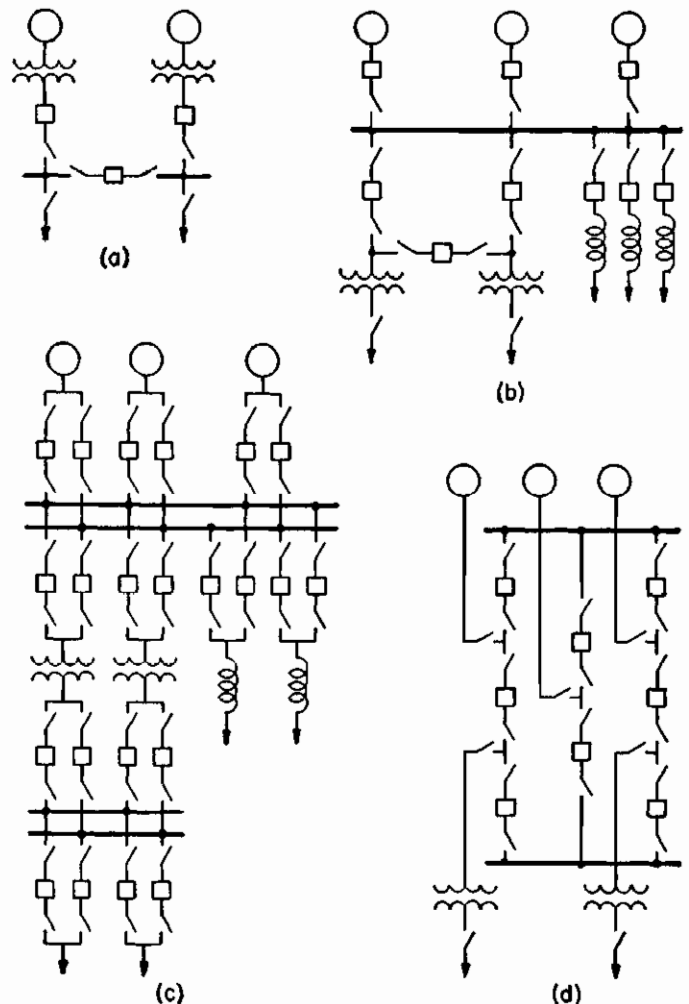

Fig. 9—Fundamental schemes of supply at higher than generated voltage.

through a station transformer connected directly to the generator terminals, an independent supply being provided for the initial start-up and for subsequent emergency restarts.

Sketch (b) shows the case where conditions do not permit of the transformers being associated directly with the generators because, perhaps, of outgoing feeders at generator voltage, but where the capacity of the transmission lines is such as to give an economical transformer size. Here it may be desirable to include the transformer bank as an integral part of the line and perform all switching operations on the low-voltage side. Sketch (b) shows the extreme of simplicity, which is permissible only where feeders and lines can be taken in and out of service at will, and (c) shows the other extreme where the feeders and lines are expected to be in service continuously. Sketch (d) shows an arrangement which is frequently applicable and which provides a considerable flexibility with the fewest breakers.

Figs. 8 and 9 include fundamental layouts from which almost any combination can be made to meet local conditions. The choice depends on the requirements of service continuity, the importance of which depends on two factors, the multiplicity of sources of supply, and the type of load. Some industrial loads are of such a nature that the relatively small risk of an outage does not justify duplication of buses and switching.

The same argument applies to the transmission line itself. Figure 10 shows an assumed transmission of 100 miles with two intermediate stations at 33 miles from either end. Sketch (a) is a fully-sectionalized scheme giving the ultimate in flexibility and reliability. Any section of either transmission circuit can be taken out for maintenance without the loss of generating capacity. Furthermore, except within that part of the transmission where one section is temporarily out of service, a fault on any section of circuit may also be cleared without loss of load. Sketch (b) shows the looped-in method of connection. Fewer breakers are required than for the fully sectionalized scheme, and as in (a) any section of the circuit can be removed from service without reducing power output. If, however, a second line trips out, part or all of the generating capacity may be lost. Relaying is somewhat more difficult than with (a), but not unduly so. Flexibility on the low-voltage side is retained as in (a). Sketch (c) is in effect an extension of the buses from station to station. The scheme is, of course, considerably cheaper than that in (a) and slightly less than that in (b) but can be justified only where a temporary outage of the transmission is unimportant. Relaying in (c) is complicated by the fact that ties between buses tend to equalize the currents so that several distinct relaying steps are required to clear a fault.

A proper balance must be kept between the reliability of the switching scheme used and the design of the line itself. Most line outages originate from lightning and a simplification and reduction in the cost of switching is permissible if the circuit is built lightning proof. (See Chap. 13.) On the other hand, if a line is of poor construction as regards insulation and spacing, it would not be good engineering to attempt to compensate for this by

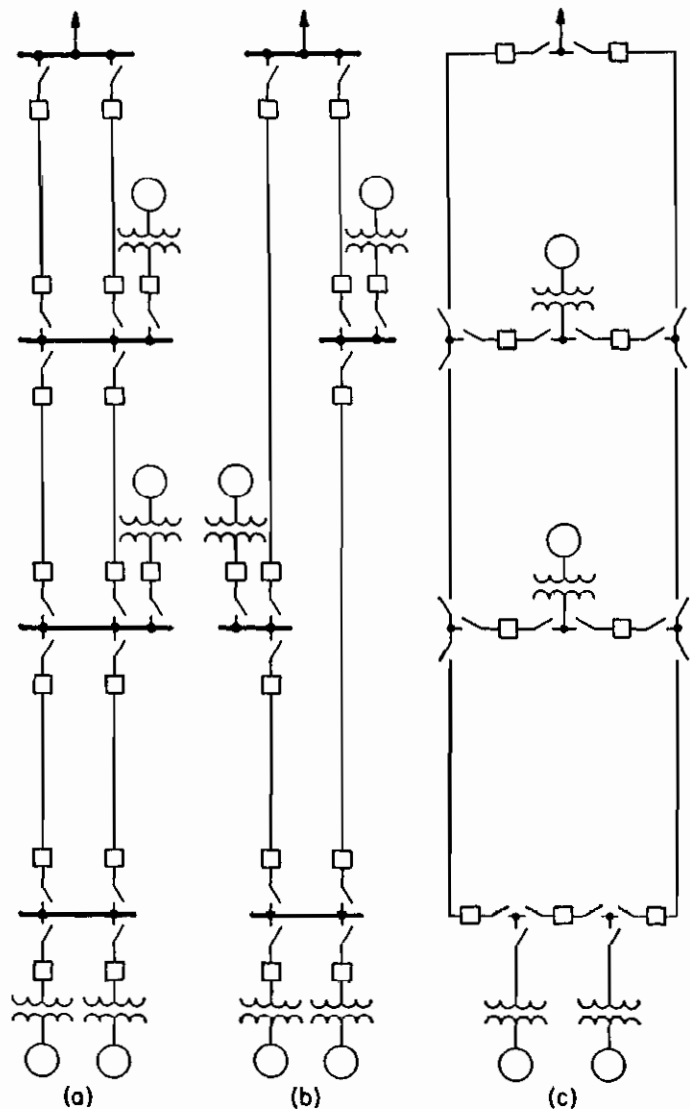

Fig. 10—Fundamental schemes of transmission. (a) Fully-sectionalized supply. (b) Looped-in supply. (c) Bussed supply.

putting in an elaborate switching and relaying scheme.

Only a few fundamental ideas have been presented on the possible layout of station buses and the switching arrangements of transmission circuits. The possible combinations are almost infinite in number and will depend on local conditions and the expenditure considered permissible for the conditions prevailing.

REFERENCES

1. Briefing the Record, edited by J. J. Jaklitsch, *Mechanical Engineering*, February 1948, p. 147.
2. Economic Balance Between Steam and Hydro Capacity, *Transactions A.S.M.E.*, Vol. 55, No. 3. Also *Electrical World*, August 30, 1932.
3. Economics of Long-Distance Energy Transmission, by R. E. Pierce and E. E. George, Ebasco Services, Inc., *A.I.E.E. Transactions*, Vol. 67, 1948, pp. 1089-1094.
4. EEI-NEMA Preferred Voltage Ratings for A-C Systems and Equipment, dated May 1949. EEI Publication No. R-6. NEMA Publication No. 117.

CHAPTER 2

SYMMETRICAL COMPONENTS

Original Author:

J. E. Hobson

Revised by:

D. L. Whitehead

THE analysis of a three-phase circuit in which phase voltages and currents are balanced (of equal magnitude in the three phases and displaced 120° from each other), and in which all circuit elements in each phase are balanced and symmetrical, is relatively simple since the treatment of a single-phase leads directly to the three-phase solution. The analysis by Kirchoff's laws is much more difficult, however, when the circuit is not symmetrical, as the result of unbalanced loads, unbalanced faults or short-circuits that are not symmetrical in the three phases. Symmetrical components is the method now generally adopted for calculating such circuits. It was presented to the engineering profession by Dr. Charles L. Fortescue in his 1918 paper, "Method of Symmetrical Coordinates Applied to the Solution of Polyphase Networks." This paper, one of the longest ever presented before the A.I.E.E., is now recognized as a classic in engineering literature. For several years symmetrical components remained the tool of the specialist; but the subsequent work of R. D. Evans, C. F. Wagner, J. F. Peters, and others in developing the sequence networks and extending the application to system fault calculations and stability calculations focused the attention of the industry on the simplification and clarification symmetrical components offered in the calculation of power system performance under unbalanced conditions.

The method was recognized immediately by a few engineers as being very useful for the analysis of unbalanced conditions on symmetrical machines. Its more general application to the calculation of power system faults and unbalances, and the simplification made possible by the use of symmetrical components in such calculations, was not appreciated until several years later when the papers by Evans, Wagner, and others were published. The use of symmetrical components in the calculation of unbalanced faults, unbalanced loads, and stability limits on three-phase power systems now overshadows the other applications.

The fundamental principle of symmetrical components, as applied to three-phase circuits, is that an unbalanced group of three related vectors (for example, three unsymmetrical and unbalanced vectors of voltage or current in a three-phase system) can be resolved into three sets of vectors. The three vectors of each set are of equal magnitude and spaced either zero or 120 degrees apart. Each set is a "symmetrical component" of the original unbalanced vectors. The same concept of resolution can be applied to rotating vectors, such as voltages or currents, or non-rotating vector operators such as impedances or admittances.

Stated in more general terms, an unbalanced group of n associated vectors, all of the same type, can be resolved into n sets of balanced vectors. The n vectors of each set are of equal length and symmetrically located with respect to each other. A set of vectors is considered to be symmetrically located if the angles between the vectors, taken in sequential order, are all equal. Thus three vectors of one set are symmetrically located if the angle between adjacent vectors is either zero or 120 degrees. Although the method of symmetrical components is applicable to the analysis of any multi-phase system, this discussion will be limited to a consideration of three-phase systems, since three phase systems are most frequently encountered.

This method of analysis makes possible the prediction, readily and accurately, of the behavior of a power system during unbalanced short-circuit or unbalanced load conditions. The engineer's knowledge of such phenomena has been greatly augmented and rapidly developed since its introduction. Modern concepts of protective relaying and fault protection grew from an understanding of the symmetrical component methods.

Out of the concept of symmetrical components have sprung, almost full-born, many electrical devices. The negative-sequence relay for the detection of system faults, the positive-sequence filter for causing generator voltage regulators to respond to voltage changes in all three phases rather than in one phase alone, and the connection of instrument transformers to segregate zero-sequence quantities for the prompt detection of ground faults are interesting examples. The HCB pilot wire relay, a recent addition to the list of devices originating in minds trained to think in terms of symmetrical components, uses a positive-sequence filter and a zero-sequence filter for the detection of faults within a protected line section and for initiating the high speed tripping of breakers to isolate the faulted section.

Symmetrical components as a tool in stability calculations was recognized in 1924-1926, and has been used extensively since that time in power system stability analyses. Its value for such calculations lies principally in the fact that it permits an unbalanced load or fault to be represented by an impedance in shunt with the single-phase representation of the balanced system.

The understanding of three-phase transformer performance, particularly the effect of connections and the phenomena associated with three-phase core-form units has been clarified by symmetrical components, as have been the physical concepts and the mathematical analysis of rotating machine performance under conditions of unbalanced faults or unbalanced loading.

The extensive use of the network calculator for the determination of short-circuit currents and voltages and for the application of circuit breakers, relays, grounding transformers, protector tubes, etc. has been furthered by the development of symmetrical components, since each sequence network may be set up independently as a single-phase system. A miniature network of an extensive power system, set up with three-phase voltages, separate impedances for each phase, and mutual impedances between phases would indeed be so large and cumbersome to handle as to be prohibitive. In this connection it is of interest to note that the network calculator has become an indispensable tool in the analysis of power system performance and in power system design.

Not only has the method been an exceedingly valuable tool in system analyses, but also, by providing new and simpler concepts the understanding of power system behavior has been clarified. The method of symmetrical components is responsible for an entirely different manner of approach to predicting and analyzing power-system performance.

Symmetrical components early earned a reputation of being complex. This is unfortunate since the mathematical manipulations attendant with the method are quite simple, requiring only a knowledge of complex vector notation. It stands somewhat unique among mathematical tools in that it has been used not only to explain existing conditions, but also, as pointed out above, the physical concepts arising from a knowledge of the basic principles have led to the development of new equipment and new schemes for power system operation, protection, etc. Things men come to know lose their mystery, and so it is with this important tool.

Inasmuch as the theory and applications of symmetrical components are fully discussed elsewhere (see references) the intention here is only to summarize the important equations and to provide a convenient reference for those who are already somewhat familiar with the subject.

I. THE VECTOR OPERATOR "a"

For convenience in notation and manipulation a vector operator is introduced. Through usage it has come to be known as the vector a and is defined as

$$a = -\frac{1}{2} + j\frac{\sqrt{3}}{2} = \epsilon^{j120} \quad (1)$$

This indicates that the vector a has unit length and is oriented 120 degrees in a positive (counter-clockwise) direction from the reference axis. A vector operated upon by a is not changed in magnitude but is simply rotated in position 120 degrees in the forward direction. For example, $V' = aV$ is a vector having the same length as the vector V , but rotated 120 degrees forward from the vector V . This relationship is shown in Fig. 1. The square of the vector a is another unit vector oriented 120 degrees in a negative (clockwise) direction from the reference axis, or oriented 240 degrees forward in a positive direction.

$$a^2 = (\epsilon^{j120})(\epsilon^{j120}) = \epsilon^{j240} = -\frac{1}{2} - j\frac{\sqrt{3}}{2} \quad (2)$$

As shown in Fig. 1, the resultant of a^2 operating on a vector V is the vector V'' having the same length as V , but located 120 degrees in a clockwise direction from V . The three vectors $1+j0$, a^2 , and a (taken in this order)

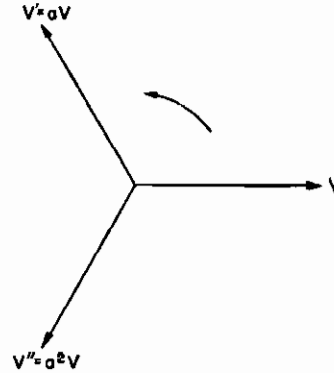

Fig. 1—Rotation of a vector by the operator a .

form a balanced, symmetrical, set of vectors of positive-phase-sequence rotation, since the vectors are of equal length, displaced equal angles from each other, and cross the reference line in the order 1, a^2 , and a (following the usual convention of counter-clockwise rotation for the

TABLE 1—PROPERTIES OF THE VECTOR OPERATOR "a"

$$\begin{aligned}
 1 &= 1 + j0 = \epsilon^{j0} \\
 a &= -\frac{1}{2} + j\frac{\sqrt{3}}{2} = \epsilon^{j120} \\
 a^2 &= -\frac{1}{2} - j\frac{\sqrt{3}}{2} = \epsilon^{j240} \\
 a^3 &= 1 + j0 = \epsilon^{j0} \\
 a^4 &= a = -\frac{1}{2} + j\frac{\sqrt{3}}{2} = \epsilon^{j120} \\
 a^5 &= a^2 = -\frac{1}{2} - j\frac{\sqrt{3}}{2} = \epsilon^{j240} \\
 a + a^2 + 1 &= 0 \\
 a + a^2 &= -1 + j0 = \epsilon^{j180} \\
 a - a^2 &= 0 + j\sqrt{3} = \sqrt{3}\epsilon^{j90} \\
 a^2 - a &= 0 - j\sqrt{3} = \sqrt{3}\epsilon^{j270} \\
 1 - a &= \frac{3}{2} - j\frac{\sqrt{3}}{2} = ja^2\sqrt{3} = \sqrt{3}\epsilon^{j330} \\
 1 - a^2 &= \frac{3}{2} + j\frac{\sqrt{3}}{2} = -ja\sqrt{3} = \sqrt{3}\epsilon^{j210} \\
 a - 1 &= -\frac{3}{2} + j\frac{\sqrt{3}}{2} = -ja^2\sqrt{3} = \sqrt{3}\epsilon^{j150} \\
 a^2 - 1 &= -\frac{3}{2} - j\frac{\sqrt{3}}{2} = ja\sqrt{3} = \sqrt{3}\epsilon^{j210} \\
 1 + a &= -a^2 = \frac{1}{2} + j\frac{\sqrt{3}}{2} = \epsilon^{j60} \\
 1 + a^2 &= -a = \frac{1}{2} - j\frac{\sqrt{3}}{2} = \epsilon^{j300} \\
 (1+a)(1+a^2) &= 1 + j0 = \epsilon^{j0} \\
 (1-a)(1-a^2) &= 3 + j0 = 3\epsilon^{j0} \\
 \frac{1+a}{1+a^2} &= a = -\frac{1}{2} + j\frac{\sqrt{3}}{2} = \epsilon^{j120} \\
 \frac{1-a}{1-a^2} &= -a = \frac{1}{2} - j\frac{\sqrt{3}}{2} = \epsilon^{j300} \\
 (1+a)^2 &= a = -\frac{1}{2} + j\frac{\sqrt{3}}{2} = \epsilon^{j120} \\
 (1+a^2)^2 &= a^2 = -\frac{1}{2} - j\frac{\sqrt{3}}{2} = \epsilon^{j240}
 \end{aligned}$$

vector diagram). The vectors 1, a , and a^2 (taken in this order) form a balanced, symmetrical, set of vectors of negative-phase-sequence, since the vectors do not cross the reference line in the order named, keeping the same

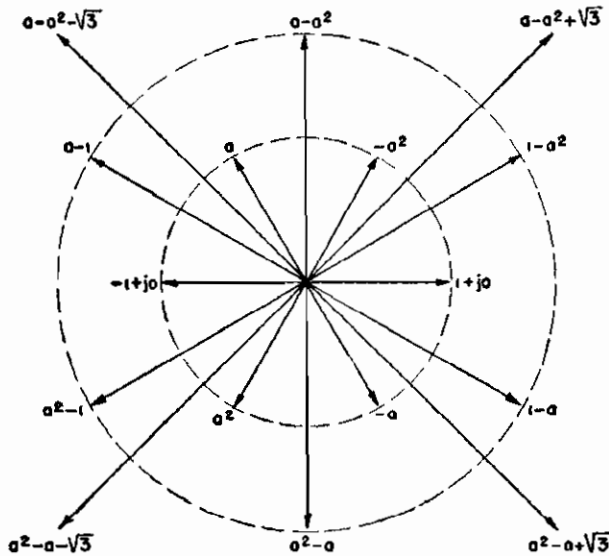

Fig. 2—Properties of the vector operator a .

convention of counterclockwise rotation, but the third named follows the first, etc.

Fundamental properties of the vector a are given in Table 1, and are shown on the vector diagram of Fig. 2.

II. RESOLUTION AND COMBINATION OF VECTOR COMPONENTS

1. Resolution of Unbalanced Three-Phase Voltages

A three-phase set of unbalanced voltage vectors is shown in Fig. 3. Any three unbalanced vectors such as those in Fig. 3 can be resolved into three balanced or symmetrical sets of vectors by the use of the following equations:

$$\begin{aligned} E_0 &= \frac{1}{3}(E_a + E_b + E_c) \\ E_1 &= \frac{1}{3}(E_a + aE_b + a^2E_c) \\ E_2 &= \frac{1}{3}(E_a + a^2E_b + aE_c) \end{aligned} \quad (3)$$

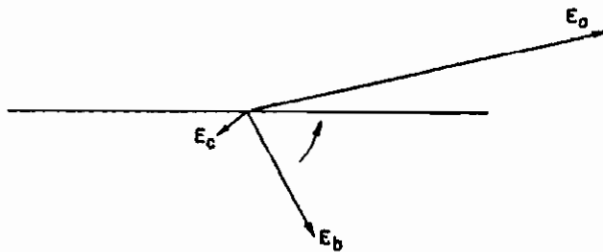

Fig. 3—Unbalanced vectors.

E_0 is the zero-sequence component of E_a , and is likewise the zero-sequence component of E_b and E_c , so that $E_0 = E_{a0} = E_{b0} = E_{c0}$. This set of three-phase vectors is shown in Fig. 4.



Fig. 4—Zero-sequence components of the vectors in Fig. 3.

E_1 is the positive-sequence component of E_a , written as E_{a1} . The positive-sequence component of E_b , E_{b1} , is equal to a^2E_{a1} . The positive-sequence component of E_c , E_{c1} , is equal to aE_{a1} . E_{a1} , E_{b1} , E_{c1} form a balanced, symmetrical three-phase set of vectors of positive phase sequence since the vector E_{a1} is 120 degrees ahead of E_{b1} and 120 degrees behind E_{c1} , as shown in Fig. 5.

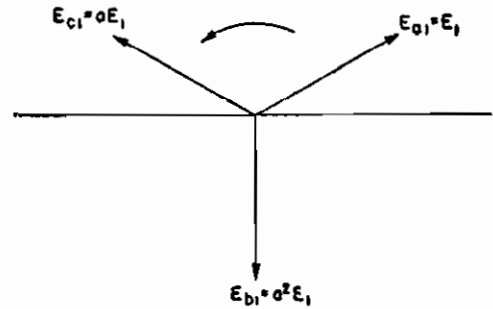

Fig. 5—Positive-sequence components of the vectors in Fig. 3.

E_2 is the negative-sequence component of E_a , written as E_{a2} . The negative-sequence components of E_b and E_c are, respectively, aE_{a2} and a^2E_{a2} , so that E_{a2} , E_{b2} , E_{c2} taken in order form a symmetrical set of negative-sequence vectors as in Fig. 6.

All three of the zero-sequence-component vectors are defined by E_0 , since $E_{a0} = E_{b0} = E_{c0}$. Likewise, the three

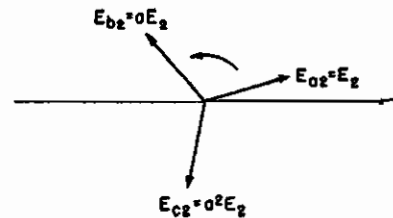

Fig. 6—Negative-sequence components of the vectors in Fig. 3.

positive-sequence vectors are defined by E_1 , since $E_{a1} = E_1$, $E_{b1} = a^2E_1$, and $E_{c1} = aE_1$. Similarly the three negative-sequence vectors are defined by E_2 . Thus all nine component vectors of the three original unbalanced vectors are completely defined by E_0 , E_1 , and E_2 ; and it is understood that E_0 , E_1 , and E_2 , are the zero-, positive-, and negative-sequence components of E_a without writing E_{a0} , etc. The three original unbalanced vectors possess six degrees of freedom, since an angle and a magnitude are necessary to define each vector. The nine component vectors also possess six degrees of freedom, since each of the three sets of component vectors is described by one angle and one magnitude; for example, the three positive-sequence vectors E_{a1} , E_{b1} , and E_{c1} , are defined by the angular position and magnitude of E_1 .

Note that all three sets of component vectors have the same counterclockwise direction of rotation as was assumed for the original unbalanced vectors. The negative-sequence set of vectors does not rotate in a direction opposite to the positive-sequence set; but the phase-sequence, that is, the order in which the maximum occur with time, of the negative-sequence set is a, c, b, a, and therefore opposite to the a, b, c, a, phase-sequence of the positive-sequence set.

The unbalanced vectors can be expressed as functions of the three components just defined:

$$\begin{aligned} E_a &= E_{a0} + E_{a1} + E_{a2} = E_0 + E_1 + E_2 \\ E_b &= E_{b0} + E_{b1} + E_{b2} = E_0 + a^2 E_1 + a E_2 \\ E_c &= E_{c0} + E_{c1} + E_{c2} = E_0 + a E_1 + a^2 E_2 \end{aligned} \quad (4)$$

The combination of the sequence component vectors to form the original unbalanced vectors is shown in Fig. 7.

In general a set of three unbalanced vectors such as those in Fig. 3 will have zero-, positive-, and negative-

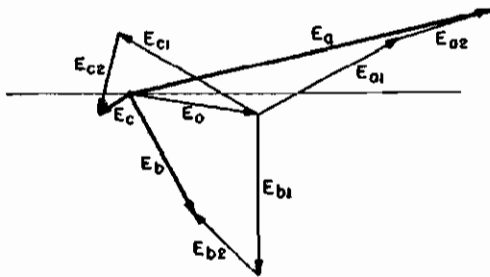

Fig. 7—Combination of the three symmetrical component sets of vectors to obtain the original unbalanced vectors in Fig. 3.

sequence components. However, if the vectors are balanced and symmetrical—of equal length and displaced 120 degrees from each other—there will be only a positive-sequence component, or only a negative-sequence component, depending upon the order of phase sequence for the original vectors.

Equations (3) can be used to resolve either line-to-neutral voltages or line-to-line voltages into their components. Inherently, however, since three delta or line-to-line voltages must form a closed triangle, there will be no zero-sequence component for a set of three-phase line-to-line voltages, and $E_{0D} = \frac{1}{3} (E_{ab} + E_{bc} + E_{ca}) = 0$. The subscript "D" is used to denote components of delta voltages or currents flowing in delta windings.

In many cases it is desirable to know the ratio of the negatives- to positive-sequence amplitudes and the phase angle between them. This ratio is commonly called the unbalance factor and can be conveniently obtained from the chart given in Fig. 8. The angle, θ , by which E_{a2} leads E_{a1} can be obtained also from the same chart. The chart is applicable only to three-phase, three-wire systems, since it presupposes no zero-sequence component. The only data needed to use the chart is the scalar magnitudes of the three line voltages. As an example the chart can be used to determine the unbalance in phase voltages permissible on induction motors without excessive heating. This limit has usually been expressed as a permissible

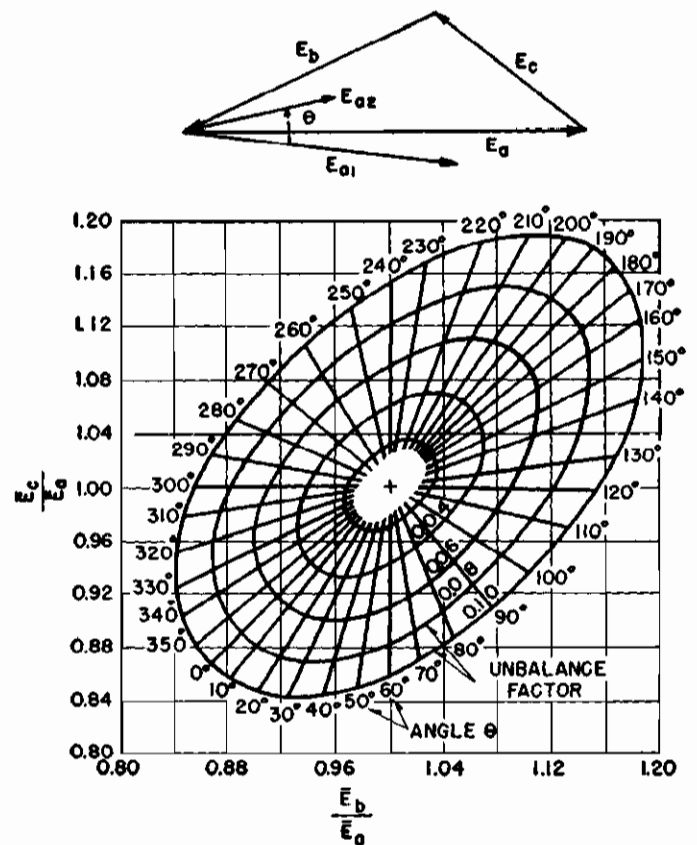

Fig. 8—Determination of unbalance factor.

negative sequence voltage whereas the phase voltages are of course more readily measured.

2. Resolution of Unbalanced Three-Phase Currents

Three line currents can be resolved into three sets of symmetrical component vectors in a manner analogous to that just given for the resolution of voltages.

Referring to Fig. 9:

$$\begin{aligned} I_0 &= I_{a0} = \frac{1}{3} (I_a + I_b + I_c) \\ I_1 &= I_{a1} = \frac{1}{3} (I_a + a I_b + a^2 I_c) \\ I_2 &= I_{a2} = \frac{1}{3} (I_a + a^2 I_b + a I_c) \end{aligned} \quad (5)$$

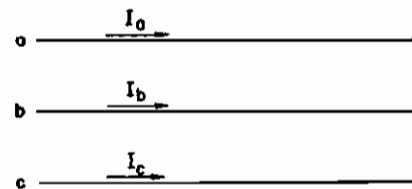

Fig. 9—Three-phase line currents.

The above are, respectively, the zero-, positive-, and negative-sequence components of I_a , the current in the reference phase.

$$\begin{aligned} I_a &= I_{a0} + I_{a1} + I_{a2} = I_0 + I_1 + I_2 \\ I_b &= I_{b0} + I_{b1} + I_{b2} = I_0 + a^2 I_1 + a I_2 \\ I_c &= I_{c0} + I_{c1} + I_{c2} = I_0 + a I_1 + a^2 I_2 \end{aligned} \quad (6)$$

Three delta currents, Fig. 10, can be resolved into components:

$$\begin{aligned} I_{0D} &= \frac{1}{3}(I_x + I_y + I_z) \\ I_{1D} &= \frac{1}{3}(I_x + aI_y + a^2I_z) \\ I_{2D} &= \frac{1}{3}(I_x + a^2I_y + aI_z) \end{aligned} \quad (7)$$

Where I_x has been chosen as the reference phase current.

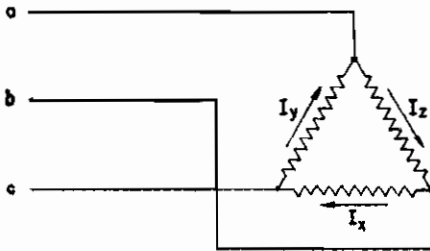

Fig. 10—Three-phase delta currents.

Three line currents flowing into a delta-connected load, or into a delta-connected transformer winding, cannot have a zero-sequence component since $I_a + I_b + I_c$ must obviously be equal to zero. Likewise the currents flowing into a star-connected load cannot have a zero-sequence component unless the neutral wire is returned or the neutral point is connected to ground. Another way of stating this fact is that zero-sequence current cannot flow into a delta-connected load or transformer bank; nor can zero-sequence current flow into a star-connected load or transformer bank unless the neutral is grounded or connected to a return neutral wire.

The choice of which phase to use as reference is entirely arbitrary, but once selected, this phase must be kept as the reference for voltages and currents throughout the system, and throughout the analysis. It is customary in symmetrical component notation to denote the reference phase as "phase a". The voltages and currents over an entire system are then expressed in terms of their components, all referred to the components of the reference phase. The components of voltage, current, impedance, or power found by analysis are directly the components of the reference phase, and the components of voltage, current, impedance, or power for the other phases are easily found by rotating the positive- or negative-sequence components of the reference-phase through the proper angle. The ambiguity possible where star-delta transformations of voltage and current are involved, or where the components of star voltages and currents are to be related to delta voltages and currents, is detailed in a following section.

3. Resolution of Unbalanced Impedances and Admittances

Self Impedances—Unbalanced impedances can be resolved into symmetrical components, although the impedances are vector operators, and not rotating vectors as are three-phase voltages and currents. Consider the three star-impedances of Fig. 11(a), which form an unbalanced load. Their sequence components are:

$$\begin{aligned} Z_0 &= \frac{1}{3}(Z_a + Z_b + Z_c) \\ Z_1 &= \frac{1}{3}(Z_a + aZ_b + a^2Z_c) \\ Z_2 &= \frac{1}{3}(Z_a + a^2Z_b + aZ_c) \end{aligned} \quad (8)$$

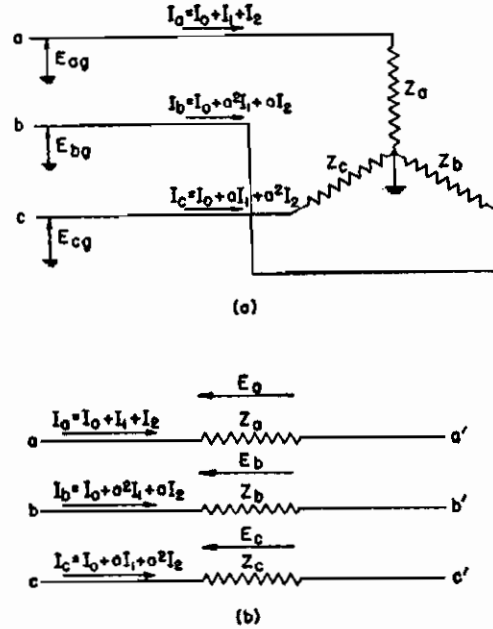

Fig. 11—Three unbalanced self impedances.

The sequence components of current through the impedances, and the sequence components of the line voltages impressed across them are interrelated by the following equations:

$$\begin{aligned} E_0 &= \frac{1}{3}(E_{ag} + E_{bg} + E_{cg}) = I_0Z_0 + I_1Z_2 + I_2Z_1 \\ E_1 &= \frac{1}{3}(E_{ag} + aE_{bg} + a^2E_{cg}) = I_0Z_1 + I_1Z_0 + I_2Z_2 \\ E_2 &= \frac{1}{3}(E_{ag} + a^2E_{bg} + aE_{cg}) = I_0Z_2 + I_1Z_1 + I_2Z_0 \end{aligned} \quad (9)$$

The above equations illustrate the fundamental principle that there is mutual coupling between sequences when the circuit constants are not symmetrical. As the equations reveal, both positive- and negative-sequence current (as well as zero-sequence current) create a zero-sequence voltage drop. If $Z_a = Z_b = Z_c$, the impedances are symmetrical, $Z_1 = Z_2 = 0$, and $Z_0 = Z_a$. For this condition,

$$\begin{aligned} E_0 &= I_0Z_0 \\ E_1 &= I_1Z_0 \\ E_2 &= I_2Z_0 \end{aligned} \quad (10)$$

and, as expected, the sequences are independent. If the neutral point is not grounded in Fig. 11(a), $I_0 = 0$ but $E_0 = I_1Z_2 + I_2Z_1$ so that there is a zero-sequence voltage, representing a neutral voltage shift, created by positive- and negative-sequence current flowing through the unbalanced load.

Equations (8) and (9) also hold for unsymmetrical series line impedances, as shown in Fig. 11(b), where E_0 , E_1 , and E_2 are components of E_a , E_b , and E_c , the voltage drops across the impedances in the three phases.

Mutual Impedances between phases can also be resolved into components. Consider Z_{mbc} of Fig. 12(a), as reference, then

$$\begin{aligned} Z_{m0} &= \frac{1}{3}(Z_{mbc} + Z_{mca} + Z_{mab}) \\ Z_{m1} &= \frac{1}{3}(Z_{mbc} + aZ_{mca} + a^2Z_{mab}) \\ Z_{m2} &= \frac{1}{3}(Z_{mbc} + a^2Z_{mca} + aZ_{mab}) \end{aligned} \quad (11)$$

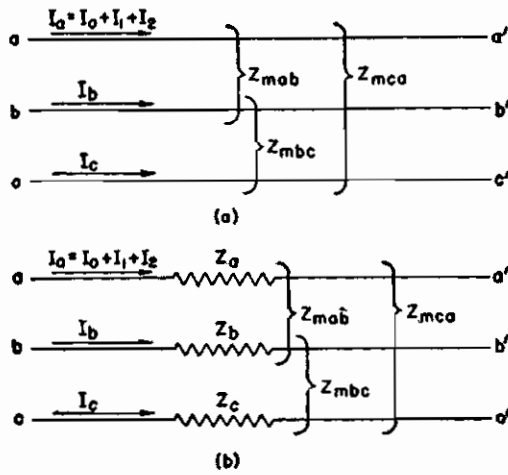

Fig. 12

- (a) Three unbalanced mutual impedances.
- (b) Unbalanced self and mutual impedances.

The components of the three-phase line currents and the components of the three-phase voltage drops created by the mutual impedances will be interrelated by the following equations:

$$\begin{aligned} E_0 &= \frac{1}{3}(E_{aa'} + E_{bb'} + E_{cc'}) = 2I_0Z_{m0} - I_1Z_{m2} - I_2Z_{m1} \\ E_1 &= \frac{1}{3}(E_{aa'} + aE_{bb'} + a^2E_{cc'}) = -I_0Z_{m1} - I_1Z_{m0} + 2I_2Z_{m2} \\ E_2 &= \frac{1}{3}(E_{aa'} + a^2E_{bb'} + aE_{cc'}) = -I_0Z_{m2} + 2I_1Z_{m1} - I_2Z_{m0} \end{aligned} \quad (12)$$

If, as in Fig. 12(b), both self and mutual impedances are present in a section of a three-phase circuit, the symmetrical components of the three voltage drops across the section are:

$$\begin{aligned} E_0 &= \frac{1}{3}(E_{aa'} + E_{bb'} + E_{cc'}) \\ &= I_0(Z_0 + 2Z_{m0}) + I_1(Z_2 - Z_{m2}) + I_2(Z_1 - Z_{m1}) \\ E_1 &= \frac{1}{3}(E_{aa'} + aE_{bb'} + a^2E_{cc'}) \\ &= I_0(Z_1 - Z_{m1}) + I_1(Z_0 - Z_{m0}) + I_2(Z_2 + 2Z_{m2}) \\ E_2 &= \frac{1}{3}(E_{aa'} + a^2E_{bb'} + aE_{cc'}) \\ &= I_0(Z_2 - Z_{m2}) + I_1(Z_1 + 2Z_{m1}) + I_2(Z_0 - Z_{m0}) \end{aligned} \quad (13)$$

Again, if both self and mutual impedances are symmetrical, in all three phases,

$$\begin{aligned} E_0 &= I_0(Z_0 + 2Z_{m0}) = I_0Z_0 \\ E_1 &= I_1(Z_0 - Z_{m0}) = I_1Z_1 \\ E_2 &= I_2(Z_0 - Z_{m0}) = I_2Z_2 \end{aligned} \quad (14)$$

Where Z_0 , Z_1 , and Z_2 are, respectively, the impedance to zero-, positive-, and negative-sequence. For this condition positive-sequence currents produce only a positive-sequence voltage drop, etc. Z_0 , Z_1 , and Z_2 are commonly referred to as the zero-sequence, positive-sequence, and negative-sequence impedances. Note, however, that this is not strictly correct and that Z_1 , the impedance to positive-sequence currents, should not be confused with Z_1 , the positive sequence component of self impedances. Since Z_0 , Z_1 , and Z_2 are used more frequently than Z_0 , Z_1 , and Z_2 the shorter expression "zero-sequence impedance" is usually used to refer to Z_0 rather than Z . For a circuit that has only symmetrical impedances, both self and mutual, the sequences are independent of each other, and positive-sequence currents produce only posi-

tive-sequence voltage drops, etc. Fortunately, except for unsymmetrical loads, unsymmetrical transformer connections, etc., the three-phase systems usually encountered are symmetrical (or balanced) and the sequences are independent.

Admittances can be resolved into symmetrical components, and the components used to find the sequence components of the currents through a three-phase set of line impedances, or star-connected loads, as functions of the symmetrical components of the voltage drops across the impedances. In Fig. 11(a), let $Y_a = \frac{1}{Z_a}$, $Y_b = \frac{1}{Z_b}$, $Y_c = \frac{1}{Z_c}$, then

$$\begin{aligned} Y_0 &= \frac{1}{3}(Y_a + Y_b + Y_c) \\ Y_1 &= \frac{1}{3}(Y_a + aY_b + a^2Y_c) \\ Y_2 &= \frac{1}{3}(Y_a + a^2Y_b + aY_c) \end{aligned} \quad (15)$$

and

$$\begin{aligned} I_0 &= E_0Y_0 + E_1Y_2 + E_2Y_1 \\ I_1 &= E_0Y_1 + E_1Y_0 + E_2Y_2 \\ I_2 &= E_0Y_2 + E_1Y_1 + E_2Y_0 \end{aligned} \quad (16)$$

Note, however, that Y_0 is not the reciprocal of Z_0 , as defined in Eq. 8, Y_1 is not the reciprocal of Z_1 , and Y_2 is not the reciprocal of Z_2 , unless $Z_a = Z_b = Z_c$; in other words, the components of admittance are not reciprocals of the corresponding components of impedance unless the three impedances (and admittances) under consideration are equal.

4. Star-Delta Conversion Equations

If a delta arrangement of impedances, as in Fig. 13(a), is to be converted to an equivalent star shown in Fig. 13(b), the following equations are applicable.

$$\begin{aligned} Z_a &= \frac{1}{Y_a} = \frac{Z_{ab} \times Z_{ca}}{Z_{ab} + Z_{bc} + Z_{ca}} \\ Z_b &= \frac{1}{Y_b} = \frac{Z_{ab} \times Z_{bc}}{Z_{ab} + Z_{bc} + Z_{ca}} \\ Z_c &= \frac{1}{Y_c} = \frac{Z_{bc} \times Z_{ca}}{Z_{ab} + Z_{bc} + Z_{ca}} \end{aligned} \quad (17)$$

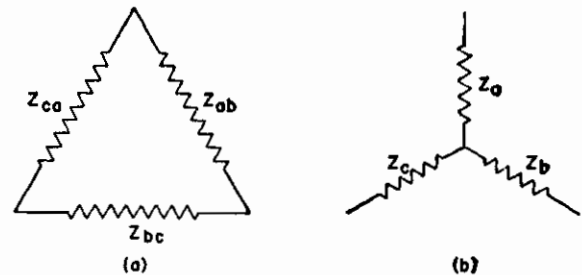

Fig. 13—Star-delta impedance conversions.

When the delta impedances form a three-phase load, no zero-sequence current can flow from the line to the load; hence, the equivalent star load must be left with neutral ungrounded.

The reverse transformation, from the star impedances of Fig. 13(b), to the equivalent delta Fig. 13(a), is given by

$$\begin{aligned} Z_{ab} &= Z_a + Z_b + \frac{Z_a Z_b}{Z_c} \\ Z_{bc} &= Z_b + Z_c + \frac{Z_b Z_c}{Z_a} \\ Z_{ca} &= Z_c + Z_a + \frac{Z_c Z_a}{Z_b} \end{aligned} \tag{18}$$

An equivalent delta for a star-connected, three-phase load with neutral grounded cannot be found, since zero-sequence current can flow from the line to the star load and return in the ground, but cannot flow from the line to any delta arrangement.

III. RELATIONSHIP BETWEEN SEQUENCE COMPONENTS OF LINE-TO-LINE AND LINE-TO-NEUTRAL VOLTAGES

Assume that E_{ag} , E_{bg} , and E_{cg} , are a positive-sequence set of line-to-neutral vectors in Fig. 14(a). The line-to-line voltages will also form a positive-sequence set of

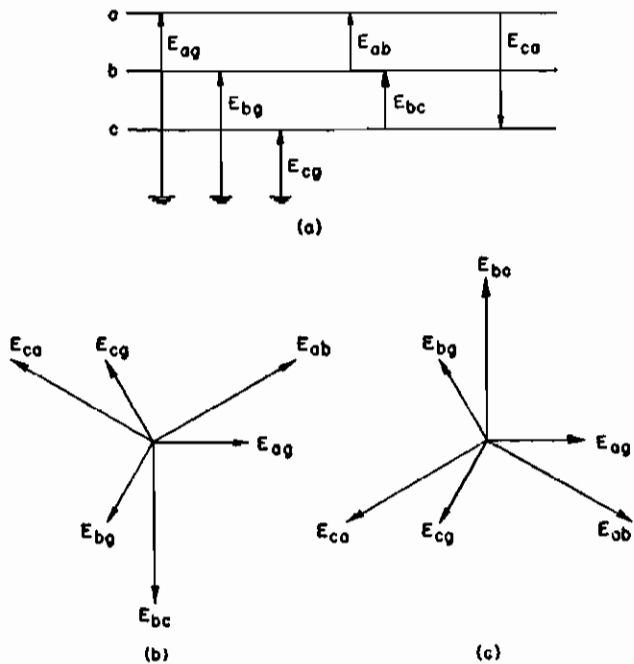

Fig. 14—Relationships between line-to-line and line-to-neutral components of voltage.

- (b) Positive-sequence relationships.
- (c) Negative-sequence relationships.

vectors. The relationship between the two sets of three-phase vectors is shown in Fig. 14(b). Although E_{1D} (the positive-sequence component of the line-to-line voltages) will be numerically equal to $\sqrt{3}E_1 - E_1$ is the positive-sequence component of the line-to-neutral voltages (which is equal in this case to E_{ag}); the angular relationship between E_1 and E_{1D} depends upon the line-to-line voltage taken as reference. The choice is arbitrary. Table 2 gives the relation between E_{1D} and E_1 for various line-to-line phases selected as reference.

TABLE 2

Reference Phase Line-to-Line Voltages	Positive-Sequence Line-to-Line Voltage As a Function of Positive Sequence Line-to-Neutral Voltage
AB	$E_{1D} = E_{ab} = \sqrt{3}E_1 \epsilon^{j30} = (1 - a^2)E_1$
BC	$E_{1D} = E_{bc} = -j\sqrt{3}E_1 = (a^2 - a)E_1$
CA	$E_{1D} = E_{ca} = \sqrt{3}E_1 \epsilon^{j150} = (a - 1)E_1$
BA	$E_{1D} = E_{ba} = \sqrt{3}E_1 \epsilon^{-j150} = (a^2 - 1)E_1$
CB	$E_{1D} = E_{cb} = j\sqrt{3}E_1 = (a - a^2)E_1$
AC	$E_{1D} = E_{ac} = \sqrt{3}E_1 \epsilon^{-j30} = (1 - a)E_1$

If E_{ag} , E_{bg} , and E_{cg} , form a negative-sequence set of vectors, the vector diagram of Fig. 14(c) illustrates the relation between $E_2 = E_{ag}$, and E_{2D} , the negative-sequence component of the line-to-line voltages. Again, the algebraic relation expressing E_{2D} as a function of E_2 will depend upon the line-to-line phase selected for reference, as illustrated in Table 3.

TABLE 3

Reference Phase	Negative-Sequence Line-to-Line Voltage As a Function of Negative Sequence Line-to-Neutral Voltage
AB	$E_{2D} = E_{ab} = \sqrt{3}E_2 \epsilon^{-j30} = (1 - a)E_2$
BC	$E_{2D} = E_{bc} = j\sqrt{3}E_2 = (a - a^2)E_2$
CA	$E_{2D} = E_{ca} = \sqrt{3}E_2 \epsilon^{-j150} = (a^2 - 1)E_2$
BA	$E_{2D} = E_{ba} = \sqrt{3}E_2 \epsilon^{j150} = (a - 1)E_2$
CB	$E_{2D} = E_{cb} = -j\sqrt{3}E_2 = (a^2 - a)E_2$
AC	$E_{2D} = E_{ac} = \sqrt{3}E_2 \epsilon^{j30} = (1 - a^2)E_2$

Since the line-to-line voltages cannot have a zero-sequence component, $E_{0D} = 0$ under all conditions, and E_0 is an indeterminate function of E_{0D} .

The equations expressing E_{1D} as a function of E_1 , and E_{2D} as a function of E_2 , can be solved to express E_1 and E_2 as functions of E_{1D} and E_{2D} , respectively. Refer to Table 4 for the relationships.

TABLE 4

Reference Phase		
AB	$E_1 = \frac{E_{1D}}{\sqrt{3}} \epsilon^{-j30} = \frac{1-a}{3} E_{1D}$	$E_2 = \frac{E_{2D}}{\sqrt{3}} \epsilon^{j30} = \frac{1-a^2}{3} E_{2D}$
BC	$E_1 = j \frac{E_{1D}}{\sqrt{3}} = \frac{a-a^2}{3} E_{1D}$	$E_2 = -j \frac{E_{2D}}{\sqrt{3}} = \frac{a^2-a}{3} E_{2D}$
CA	$E_1 = \frac{E_{1D}}{\sqrt{3}} \epsilon^{-j150} = \frac{a^2-1}{3} E_{1D}$	$E_2 = \frac{E_{2D}}{\sqrt{3}} \epsilon^{j150} = \frac{a-1}{3} E_{2D}$
BA	$E_1 = \frac{E_{1D}}{\sqrt{3}} \epsilon^{j150} = \frac{a-1}{3} E_{1D}$	$E_2 = \frac{E_{2D}}{\sqrt{3}} \epsilon^{-j150} = \frac{a^2-1}{3} E_{2D}$
CB	$E_1 = -j \frac{E_{1D}}{\sqrt{3}} = \frac{a^2-a}{3} E_{1D}$	$E_2 = j \frac{E_{2D}}{\sqrt{3}} = \frac{a-a^2}{3} E_{2D}$
AC	$E_1 = \frac{E_{1D}}{\sqrt{3}} \epsilon^{j30} = \frac{1-a^2}{3} E_{1D}$	$E_2 = \frac{E_{2D}}{\sqrt{3}} \epsilon^{-j30} = \frac{1-a}{3} E_{2D}$

Certain authors have arbitrarily adopted phase CB as reference, since the relations between the line-to-line and line-to-neutral components are easily remembered and the angular shift of 90 degrees is easy to carry in computations. Using this convention:

$$\begin{aligned}
 E_{1D} &= j\sqrt{3}E_1 & E_1 &= -j\frac{E_{1D}}{\sqrt{3}} \\
 E_{2D} &= -j\sqrt{3}E_2 & E_2 &= j\frac{E_{2D}}{\sqrt{3}} \\
 E_{0D} &= 0 & E_0 & \text{is not a function of } E_{0D}
 \end{aligned} \quad (19)$$

The equations and vector diagrams illustrate the interesting fact that the numerical relation between the line-to-line and line-to-neutral positive-sequence components is the same as for negative-sequence; but that the angular shift for negative-sequence is opposite to that for positive-sequence, regardless of the delta phase selected for reference. Also, a connection of power or regulating transformers giving a shift of θ degrees in the transformation for positive-sequence voltage and current will give a shift of $-\theta$ degrees in the transformation for negative-sequence voltage and current.

IV. SEQUENCE COMPONENTS OF LINE AND DELTA CURRENTS

The relation existing between the positive-sequence component of the delta currents and the positive-sequence component of the line currents flowing into a delta load or delta-connected transformer winding, and the relation existing for the negative-sequence components of the currents are given in Figs. 15(b) and 15(c). Although the components of line currents are $\sqrt{3}$ times the delta phase selected for reference, the angular relationship depends

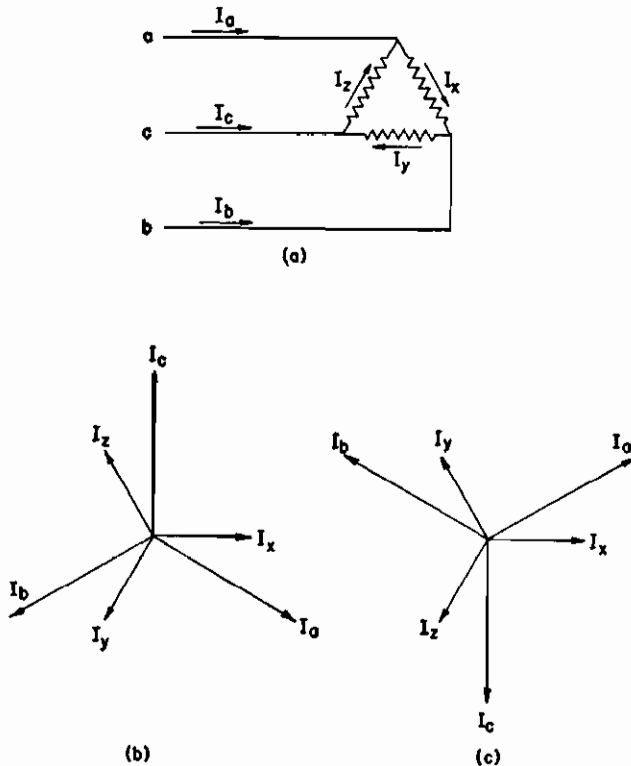

Fig. 15—Relationships between components of phase and delta currents.

- (b) Positive-sequence relationships.
(c) Negative-sequence relationships.

upon the phase selected for reference. I_a is taken as reference for the line currents. Refer to Table 5.

TABLE 5

Delta Reference Current	Fig. 14(b)	Fig. 14(c)
I_x	$I_{1D} = I_x = \frac{1}{\sqrt{3}}I_1e^{j30}$	$I_{2D} = I_x = \frac{1}{\sqrt{3}}I_2e^{-j30}$
I_y	$I_{1D} = I_y = \frac{-j}{\sqrt{3}}I_1$	$I_{2D} = I_y = \frac{j}{\sqrt{3}}I_2$
I_z	$I_{1D} = I_z = \frac{1}{\sqrt{3}}I_1e^{j150}$	$I_{2D} = I_z = \frac{1}{\sqrt{3}}I_2e^{-j150}$
$-I_x$	$I_{1D} = -I_x = \frac{1}{\sqrt{3}}I_1e^{-j150}$	$I_{2D} = -I_x = \frac{1}{\sqrt{3}}I_2e^{j150}$
$-I_y$	$I_{1D} = -I_y = \frac{j}{\sqrt{3}}I_1$	$I_{2D} = -I_y = \frac{-j}{\sqrt{3}}I_2$
$-I_z$	$I_{1D} = -I_z = \frac{1}{\sqrt{3}}I_1e^{-j30}$	$I_{2D} = -I_z = \frac{1}{\sqrt{3}}I_2e^{j30}$

If the current ($-I_y$) is taken as reference, the relations are easily remembered; also, the j operator is convenient to use in analysis.

$$\begin{aligned}
 I_{1D} &= \frac{j}{\sqrt{3}}I_1 & I_1 &= -j\sqrt{3}I_{1D} \\
 I_{2D} &= \frac{-j}{\sqrt{3}}I_2 & I_2 &= j\sqrt{3}I_{2D}
 \end{aligned} \quad (20)$$

V. STAR-DELTA TRANSFORMATIONS OF VOLTAGE AND CURRENT

Each sequence component of voltage and current must be followed separately through the transformer, and the angular shift of the sequence will depend upon the input and output phases arbitrarily selected for reference. In Fig. 16(a), the winding ratio is n and the overall transformation ratio is $N = \frac{n}{\sqrt{3}}$. Line-to-line or line-to-neutral voltages on the delta side will be N times the corresponding voltages on the star side of the transformer (neglecting impedance drop). If the transformer windings are symmetrical in the three phases, there will be no interaction between sequences, and each sequence component of voltage or current is transformed independently.

To illustrate the sequence transformations, phases a and a' have been selected as reference phases in the two circuits. Figs. 16(b), (c), (d), and (e) give the relationships for the three phases with each component of voltage and current considered separately.

From the vector diagrams

$$\begin{aligned}
 E_1' &= NE_1e^{j30} \\
 I_1' &= \frac{1}{N}I_1e^{j30} \\
 E_2' &= NE_2e^{-j30} \\
 I_2' &= \frac{1}{N}I_2e^{-j30}
 \end{aligned} \quad (21)$$

Regardless of the phases selected for reference, both positive-sequence current and voltage will be shifted in the same direction by the same angle. Negative-sequence current and voltage will also be shifted the same angle in

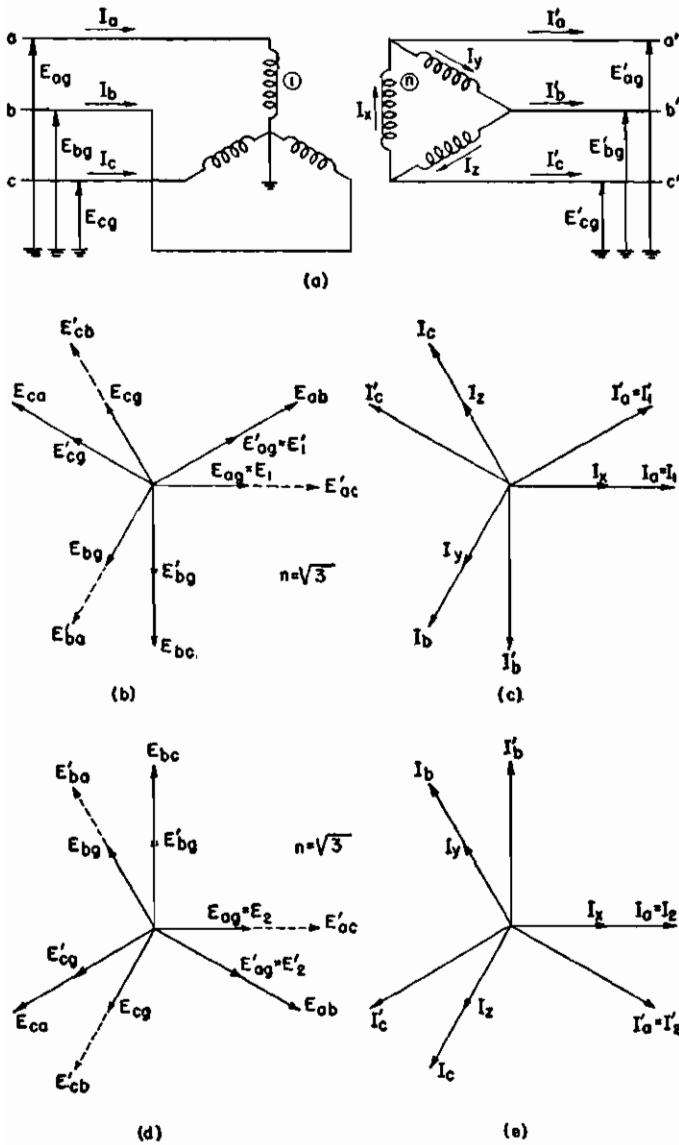

Fig. 16—Transformation of the sequence components of current and voltage in a star-delta transformer bank.

- (b) Relationship of positive-sequence line-to-neutral and line-to-line voltages.
- (c) Relationship of positive-sequence currents.
- (d) Relationship of negative-sequence line-to-neutral and line-to-line voltages.
- (e) Relationship of negative-sequence currents.

one direction, and the negative-sequence angular shift will be equal to the positive-sequence shift but in the opposite direction. As previously stated, this is a general rule for all connections of power and regulating transformers, wherever phase shift is involved in the transformation.

Since zero-sequence current cannot flow from the delta winding, there will be no zero-sequence component of I_a' . If the star winding is grounded, I_a may have a zero-sequence component. From the star side the transformer bank acts as a return path for zero-sequence current (if the neutral is grounded), and from the delta side the bank acts as an open circuit to zero-sequence. For zero-sequence current alone, $I_a = I_b = I_c = I_o$, and a current will circu-

late around the delta such that $I_x = I_y = I_z = I_{od} = \frac{1}{n} I_o$.

The zero-sequence line-to-neutral voltages, E_o and E_o' are entirely independent; each being determined by conditions in its respective circuit. The transformation characteristics for the three sequence currents and voltages, and the sequence impedance characteristics, for common connections of power and regulating transformers are given in Chap. 5. The action of a transformer bank in the transformation of zero-sequence currents must be given particular attention, since certain connections do not permit zero-sequence current to flow, others permit it to pass through the bank without transformation, and still others transform zero-sequence quantities in the same manner as positive- or negative-sequence quantities are transformed.

VI. THREE-PHASE POWER

The total three-phase power of a circuit can be expressed in terms of the symmetrical components of the line currents and the symmetrical components of the line-to-neutral voltages.

$$P = 3(E_0 I_0 \cos \theta_0 + E_1 I_1 \cos \theta_1 + E_2 I_2 \cos \theta_2) \quad (22)$$

where θ_0 is the angle between E_0 and I_0 , θ_1 the angle between E_1 and I_1 , θ_2 the angle between E_2 and I_2 . The equation shows that the total power is the sum of the three components of power; but the power in one phase of an unbalanced circuit is not one-third of the above expression, since each phase will contain components of power resulting from zero-sequence voltage and positive-sequence current, etc. This power "between sequences" is generated in one phase and absorbed by the others, and does not appear in the expression for total three-phase power.

Only positive-sequence power is developed by the generators. This power is converted to negative-sequence and zero-sequence power by circuit dissymmetry such as occurs from a single line-to-ground or a line-to-line fault. The unbalanced fault, unbalanced load, or other dissymmetry in the circuit thus acts as the "generator" for negative-sequence and zero-sequence power.

VII. CONJUGATE SETS OF VECTORS

Since power in an alternating-current circuit is defined as $E\hat{I}$ (the vector E times the conjugate of the vector I), some consideration should be given to conjugates of the symmetrical-component sets of vectors. A system of positive-sequence vectors are drawn in Fig. 17(a). In

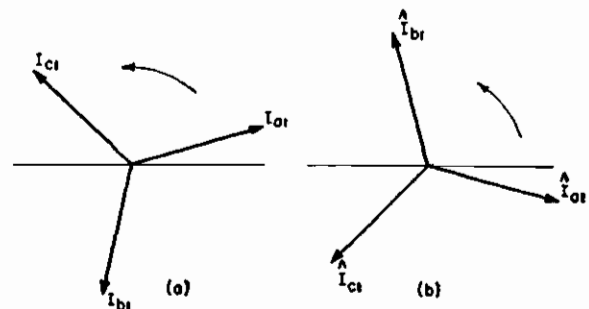

Fig. 17—Conjugates of a positive-sequence set of vectors.

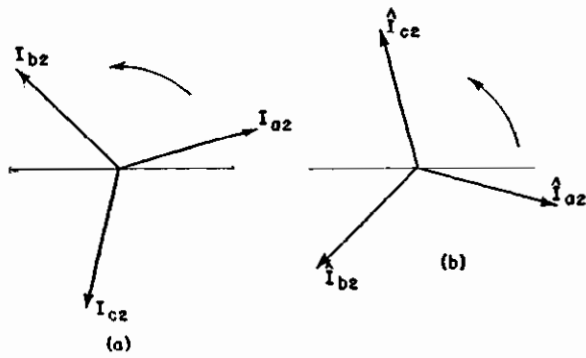

Fig. 18—Conjugates of a negative-sequence set of vectors.

accordance with the definition that the conjugate of a given vector is a vector of the same magnitude but displaced the same angle from the reference axis in the *opposite* direction to the given vector, the conjugates of the positive-sequence set of vectors are shown in Fig. 17(b). Note that the conjugates to a positive-sequence set of vectors form a negative-sequence set of vectors. Similarly, as in Fig. 18, the conjugates to a negative-sequence set of vectors form a posi-

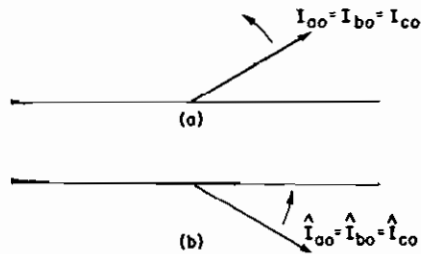

Fig. 19—Conjugates of a zero-sequence set of vectors.

tive-sequence set. The conjugate of a zero-sequence set of vectors is another zero-sequence set of vectors, see Fig. 19.

VIII. SEQUENCE NETWORKS

5. General Considerations

One of the most useful concepts arising from symmetrical components is that of the sequence network, which is an equivalent network for the balanced power system under an imagined operating condition such that only one sequence component of voltages and currents is present in the system. As shown above for the case of balanced loads (and it can be readily shown in general) currents of one sequence will create voltage drops of that sequence only, if a power system is balanced (equal series impedances in all three phases, equal mutual impedances between phases, rotating machines symmetrical in all three phases, all banks of transformers symmetrical in all three phases, etc.). There will be no interaction between sequences and the sequences are independent. Nearly all power systems can be assumed to be balanced except for emergency conditions such as short-circuits, faults, unbalanced load, unbalanced open circuits, or unsymmetrical conditions arising in rotating machines. Even under such emergency unbalanced conditions, which usually occur at only one point in the system, the remainder of the power system remains balanced and an equivalent sequence network can be ob-

tained for the balanced part of the system. The advantage of the sequence network is that, since currents and voltages of only one sequence are present, the three-phase system can be represented by an equivalent single-phase diagram. The entire sequence network can often be reduced by simple manipulation to a single voltage and a single impedance. The type of unbalance or dissymmetry in the circuit can be represented by an interconnection between the equivalent sequence networks.

The positive-sequence network is the only one of the three that will contain generated voltages, since alternators can be assumed to generate only positive-sequence voltages. The voltages appearing in the negative- and zero-sequence networks will be generated by the unbalance, and will appear as voltages impressed on the networks at the point of fault. Furthermore, the positive-sequence network represents the system operating under normal balanced conditions. For short-circuit studies the internal voltages are shorted and the positive sequence network is driven by the voltage appearing at the fault before the fault occurred according to the theory of Superposition and the Compensation Theorems (see Chapter 10, Section 11). This gives exactly the increments or changes in system quantities over the system. Since the fault current equals zero before the fault, the increment alone is the fault current total. However, the normal currents in any branch must be added to the calculated fault current in the same branch to get the total current in any branch after the fault occurs.

6. Setting Up the Sequence Networks

The equivalent circuits for each sequence are set up “as viewed from the fault,” by imagining current of the particular sequence to be circulated through the network from the fault point, investigating the path of current flow and the impedance of each section of the network to currents of that sequence. Another approach is to imagine in each network a voltage impressed across the terminals of the network, and to follow the path of current flow through the network, dealing with each sequence separately. It is particularly necessary when setting up the zero-sequence network to start at the fault point, or point of unbalance, since zero-sequence currents might not flow over the entire system. Only parts of the system over which zero-sequence current will flow, as the result of a zero-sequence voltage impressed at the unbalanced point, are included in the zero-sequence network “as viewed from the fault.” The two terminals for each network correspond to the two points in the three-phase system on either side of the unbalance. For the case of shunt faults between conductors and ground, one terminal of each network will be the fault point in the three-phase system, the other terminal will be ground or neutral at that point. For a series unbalance, such as an open conductor, the two terminals will correspond to the two points in the three-phase system immediately adjacent to the unbalance.

7. Sequence Impedances of Lines, Transformers, and Rotating Machinery

The impedance of any unit of the system—such as a generator, a transformer, or a section of line—to be in-

serted in a sequence network is obtained by imagining unit current of that sequence to be circulated through the apparatus or line in all three phases, and writing the equation for the voltage drop; or by actually measuring the voltage drop when current of the one sequence being investigated is circulated through the three phases of the apparatus. The impedance to negative-sequence currents for all static non-rotating apparatus will be equal to the impedance for positive-sequence currents. The impedance to negative-sequence currents for rotating apparatus will in general be different from the impedance to positive sequence. The impedance to zero-sequence currents for all apparatus will in general be different from either the impedance to positive-sequence or the impedance to negative-sequence. The sequence impedance characteristics of the component parts of a power system have been investigated in detail and are discussed in Chaps. 3, 4, 5, and 6.

An impedance in the neutral will not appear in either the positive-sequence network or the negative-sequence network, since the three-phase currents of either sequence add to zero at the neutral; an equivalent impedance equal to three times the ohmic neutral impedance will appear in the zero-sequence network, however, since the zero-sequence currents flowing in the three phases, I_0 add directly to give a neutral current of $3I_0$.

8. Assumed Direction of Current Flow

By convention, the positive direction of current flow in each sequence network is taken as being outward at the faulted or unbalanced point; thus the sequence currents are assumed to flow in the same direction in all three sequence networks. This convention of assumed current flow must be carefully followed to avoid ambiguity or error even though some of the currents are negative. After the currents flowing in each network have been determined, the sequence voltage at any point in the network can be found by subtracting the impedance drops of that sequence from the generated voltages, taking the neutral point of the network as the point of zero voltage. For example, if the impedances to positive-, negative-, and zero-sequence between neutral and the point in question are Z_1 , Z_2 , and Z_0 , respectively, the sequence voltages at the point will be

$$\begin{aligned} E_1 &= E_{a1} - I_1 Z_1 \\ E_2 &= -I_2 Z_2 \\ E_0 &= -I_0 Z_0 \end{aligned} \tag{23}$$

where E_{a1} is the generated positive-sequence voltage, the positive-sequence network being the only one of the three having a generated voltage between neutral and the point for which voltages are to be found. In particular, if Z_1 , Z_2 and Z_0 are the total equivalent impedances of the networks to the point of fault, then Eq. (23) gives the sequence voltages at the fault.

Distribution Factors—If several types of unbalance are to be investigated for one point in the system, it is convenient to find distribution factors for each sequence current by circulating unit sequence current in the terminals of each network, letting it flow through the network and finding how this current distributes in various branches. Regardless of the type of fault, and the magnitude of sequence current at the fault, the current will

distribute through each network in accordance with the distribution factors found for unit current. This follows from the fact that within any one of the three networks the currents and voltages of that sequence are entirely independent of the other two sequences.

These points will be clarified by detailed consideration of a specific example at the end of this chapter.

IX. CONNECTIONS BETWEEN THE SEQUENCE NETWORKS

As discussed in Part II, Sec. 3 of this chapter, any unbalance or dissymmetry in the system will result in mutual action between the sequences, so that it is to be expected that the sequence networks will have mutual coupling, or possibly direct connections, between them at the point of unbalance. Equations can be written for the conditions existing at the point of unbalance that show the coupling or connections necessarily existing between the sequence networks at that point.

As pointed out in Sec. 5, it is usually sufficiently accurate to reduce a given system to an equivalent source and single reactance to the point of fault. This in effect means that the system is reduced to a single generator with a fault applied at its terminals. Figs. 20(a) through 20(e) show such an equivalent system with the more common types of faults applied. For example Fig. 20(a) is drawn for a three-

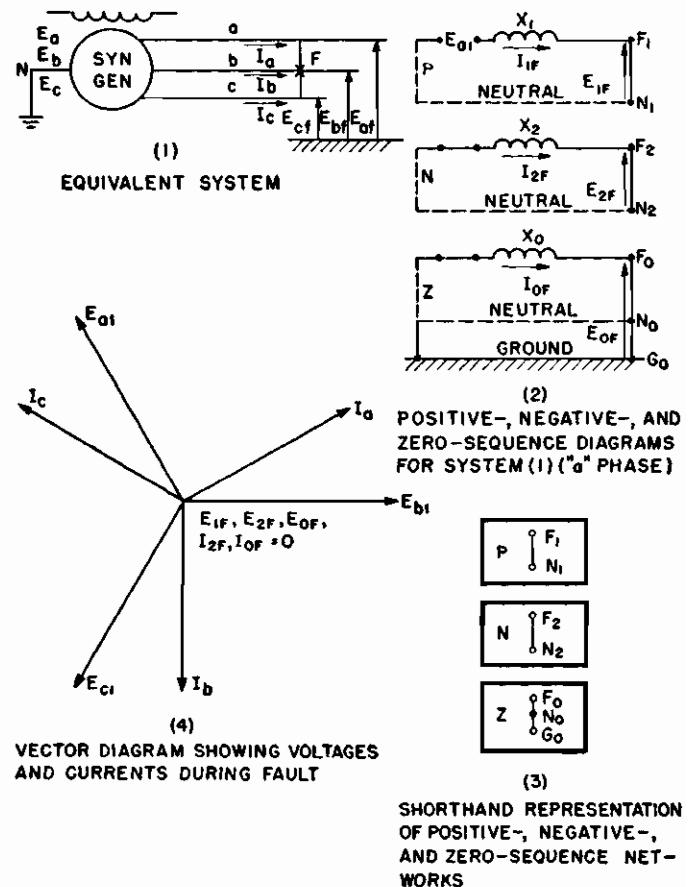

Fig. 20.

(a) Three-phase short circuit on generator.

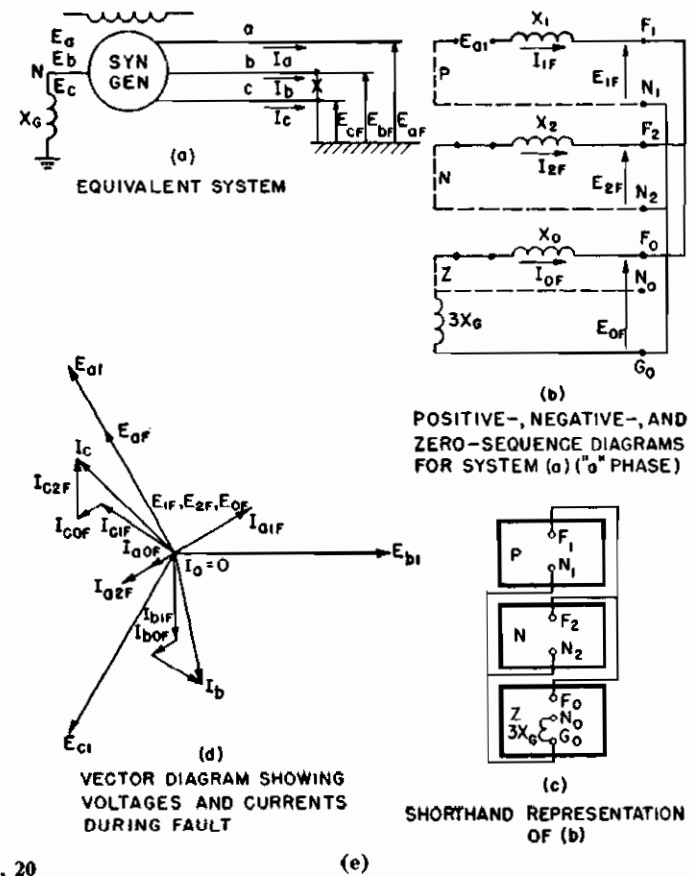
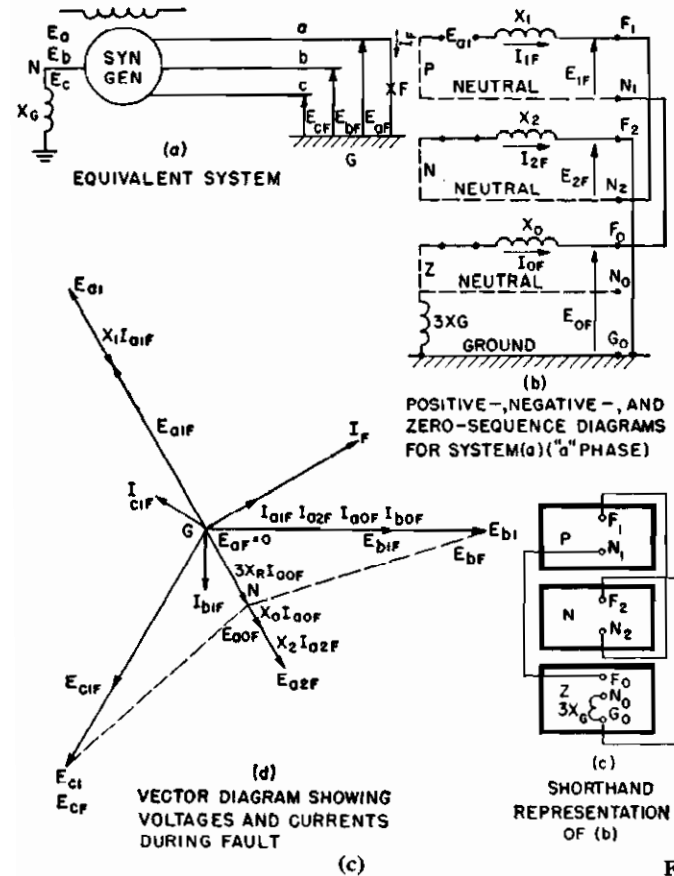
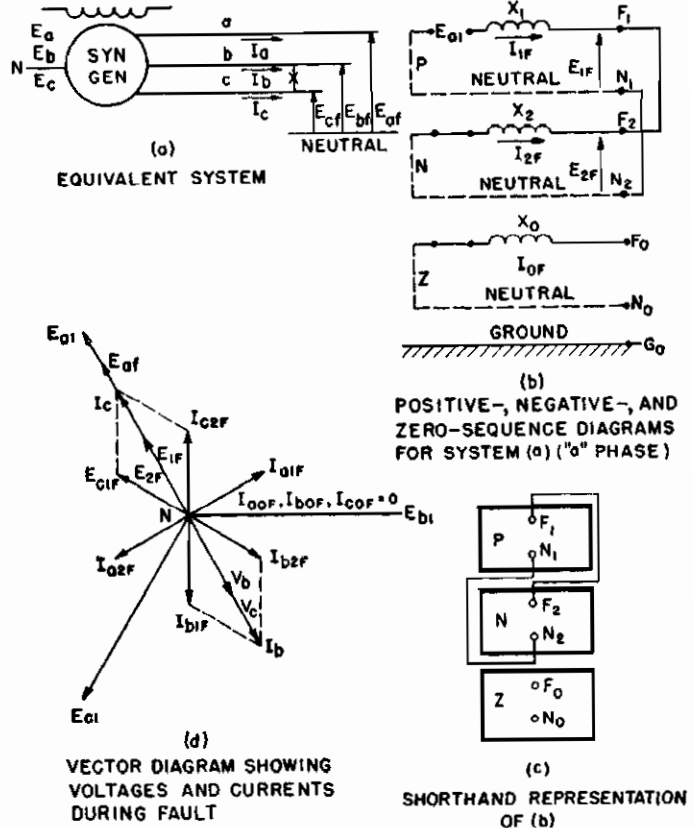
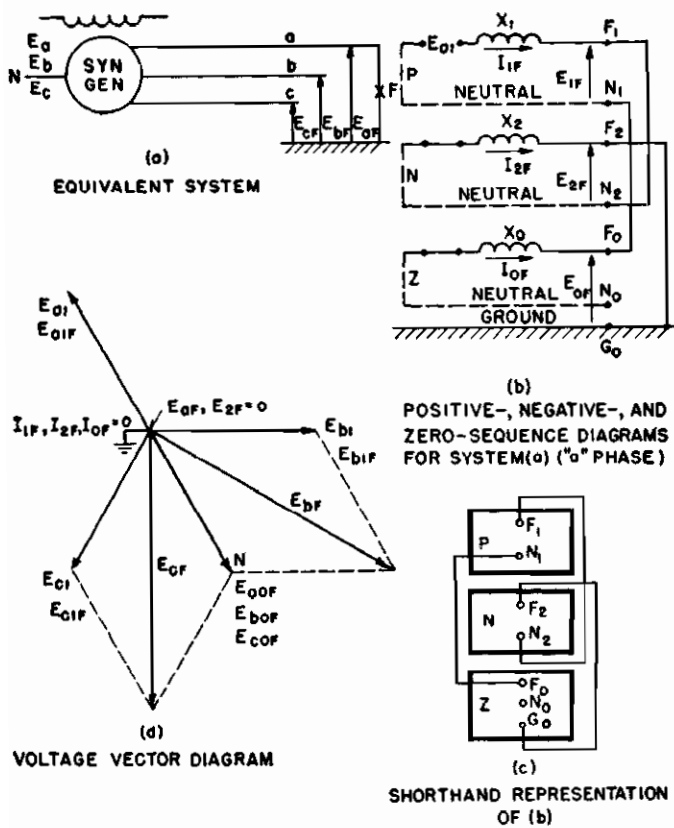

Fig. 20

- (b) Single-line-to-ground fault on ungrounded generator.
- (c) Single-line-to-ground fault on generator grounded through a neutral reactor.

- (d) Line-to-line fault on grounded or ungrounded generator.
- (e) Double-line-to-ground fault on generator grounded through a neutral reactor.

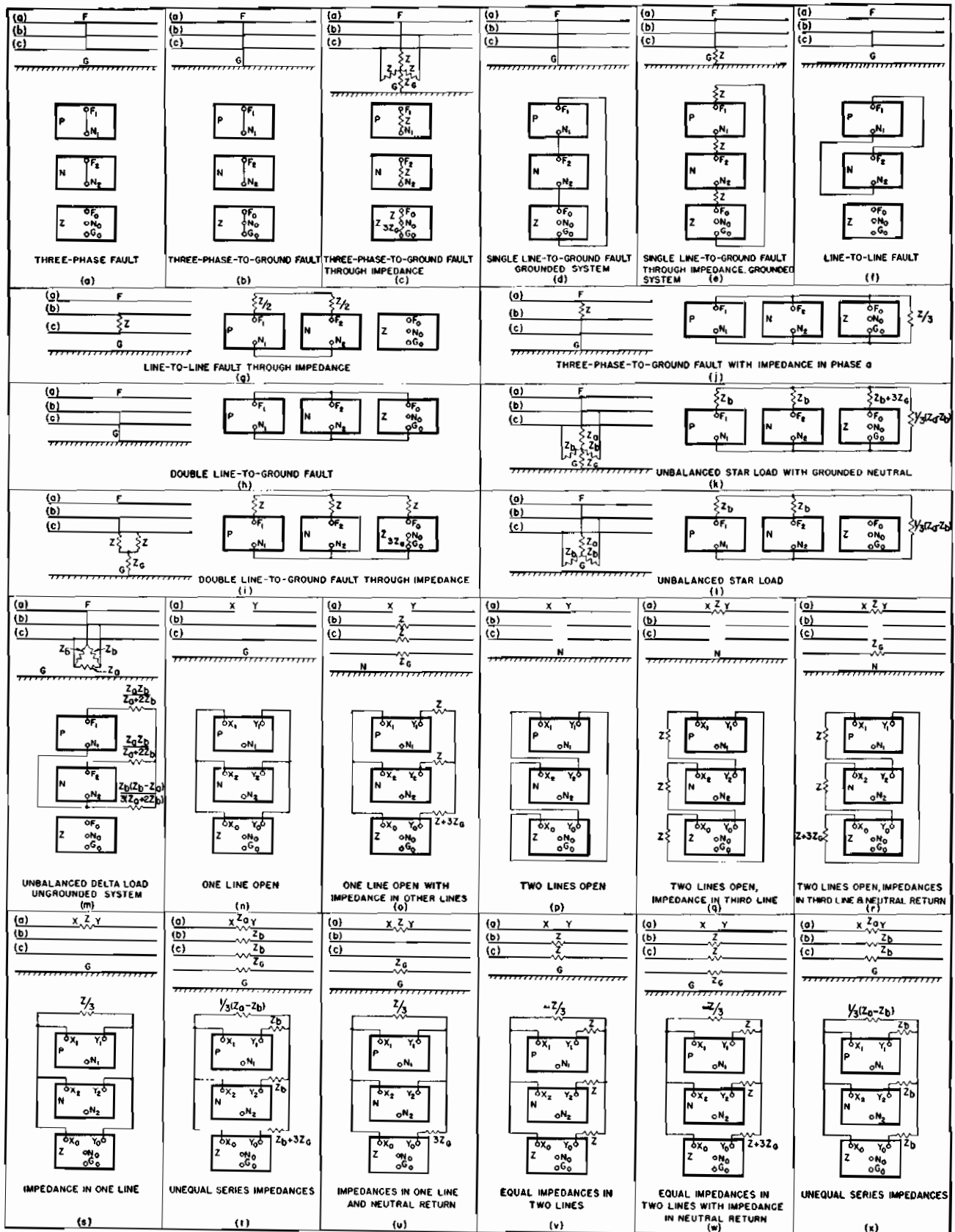

Fig. 21—Connection of the sequence networks to represent shunt and series unbalanced conditions. For shunt unbalances the faulted point in the system is represented by F and neutral by N . Corresponding points are represented in the sequence networks by the letter with a sequence subscript. P , N , and Z refer to the positive-, negative-, and zero-sequence networks, respectively. For series unbalances, points in the system adjacent to the unbalance are represented by X and Y . N is again the neutral.

phase fault on the system. Part (1) shows the equivalent system (2) the corresponding positive- negative- and zero-sequence diagrams, and (3) the shorthand representation of the sequence diagrams. Part (4) is a vector diagram showing graphically the relationship between the various voltages and currents. In the zero-sequence diagrams of (2) and (3) a distinction is made between "neutral", N , and "ground", G . In the positive- and negative-sequence networks no such distinction is necessary, since by their definition positive- and negative-sequence quantities are balanced with respect to neutral. For example, all positive- and negative-sequence currents add to zero at the system neutral so that the terms "neutral" and "ground" are synonymous. Zero-sequence quantities however, are not balanced with respect to neutral. Thus, by their nature zero-sequence currents require a neutral or ground return path. In many cases impedance exists between neutral and ground and when zero-sequence currents flow a voltage drop exists between neutral and ground. Therefore, it is necessary that one be specific when speaking of line-to-neutral and line-to-ground zero-sequence voltages. They are the same only when no impedance exists between the neutral and ground.

In parts (3) of Fig. 20(a) all portions of the network within the boxes are balanced and only the terminals at the point of unbalance are brought out. The networks as shown are for the "a" or reference phase only. In Eqs. (25) through (29) the zero-sequence impedance, Z_0 , is infinite for the case of Fig. 20(b) and includes $3X_G$ in the case of Fig. 20(c). Fig. 21 gives a summary of the connections required to represent the more common types of faults encountered in power system work.

Equations for calculating the sequence quantities at the point of unbalance are given below for the unbalanced conditions that occur frequently. In these equations E_{1F} , E_{2F} , and E_{0F} are components of the line-to-neutral voltages at the point of unbalance; I_{1F} , I_{2F} , and I_{0F} are components of the fault current I_F ; Z_1 , Z_2 , and Z_0 are impedances of the system (as viewed from the unbalanced terminals) to the flow of the sequence currents; and E_a is the line-to-neutral positive-sequence generated voltage.

9. Three-Phase Fault—Fig. 20(a)

$$I_{1F} = I_F = \frac{E_a}{Z_1} \quad (24)$$

10. Single Line-to-Ground Fault—Fig. 20(b) and 20(c)

$$I_{1F} = I_{2F} = I_{0F} = \frac{E_a}{Z_1 + Z_2 + Z_0} \quad (25)$$

$$I_F = I_{1F} + I_{2F} + I_{0F} = 3I_{0F} \quad (26)$$

$$E_{1F} = E_a - I_{1F}Z_1 = E_a \frac{(Z_2 + Z_0)}{Z_1 + Z_2 + Z_0} \quad (27)$$

$$E_{2F} = -I_{2F}Z_2 = -\frac{E_a Z_2}{Z_1 + Z_2 + Z_0} \quad (28)$$

$$E_{0F} = -I_{0F}Z_0 = -\frac{E_a Z_0}{Z_1 + Z_2 + Z_0} \quad (29)$$

11. Line-to-Line Fault—Fig. 20(d)

$$I_{1F} = -I_{2F} = \frac{E_a}{Z_1 + Z_2} \quad (30)$$

$$I_F = \sqrt{3}I_{1F} \quad (31)$$

$$E_{1F} = E_a - I_{1F}Z_1 = \frac{E_a Z_2}{Z_1 + Z_2} \quad (32)$$

$$E_{2F} = -I_{2F}Z_2 = \frac{E_a Z_2}{Z_1 + Z_2} \quad (33)$$

12. Double Line-to-Ground Fault—Fig. 20(e)

$$I_{1F} = \frac{E_a}{Z_1 + \frac{Z_2 Z_0}{Z_2 + Z_0}} = \frac{E_a (Z_2 + Z_0)}{Z_1 Z_2 + Z_1 Z_0 + Z_2 Z_0} \quad (34)$$

$$I_{2F} = -\frac{Z_0}{Z_2 + Z_0} I_{1F} = \frac{-Z_0 E_a}{Z_1 Z_2 + Z_1 Z_0 + Z_2 Z_0} \quad (35)$$

$$I_{0F} = -\frac{Z_2}{Z_2 + Z_0} I_{1F} = \frac{-Z_2 E_a}{Z_1 Z_2 + Z_1 Z_0 + Z_2 Z_0} \quad (36)$$

$$E_{1F} = E_a - I_{1F}Z_1 = \frac{Z_2 Z_0 E_a}{Z_1 Z_2 + Z_1 Z_0 + Z_2 Z_0} \quad (37)$$

$$E_{2F} = -I_{2F}Z_2 = \frac{Z_2 Z_0 E_a}{Z_1 Z_2 + Z_1 Z_0 + Z_2 Z_0} \quad (38)$$

$$E_{0F} = -I_{0F}Z_0 = \frac{Z_2 Z_0 E_a}{Z_1 Z_2 + Z_1 Z_0 + Z_2 Z_0} \quad (39)$$

13. One Line Open—Fig. 21(n)

$$I_{1F} = \frac{E_a (Z_2 + Z_0)}{Z_1 Z_2 + Z_1 Z_0 + Z_2 Z_0} \quad (40)$$

$$I_{2F} = \frac{Z_0 E_a}{Z_1 Z_2 + Z_1 Z_0 + Z_2 Z_0} \quad (41)$$

$$I_{0F} = \frac{-Z_2 E_a}{Z_1 Z_2 + Z_1 Z_0 + Z_2 Z_0} \quad (42)$$

$$E_{1x} - E_{1y} = E_a - I_{1F}Z_1 = \frac{Z_2 Z_0 E_a}{Z_1 Z_2 + Z_1 Z_0 + Z_2 Z_0} \quad (43)$$

$$E_{2x} - E_{2y} = -I_{2F}Z_2 = \frac{Z_2 Z_0 E_a}{Z_1 Z_2 + Z_1 Z_0 + Z_2 Z_0} \quad (44)$$

$$E_{0x} - E_{0y} = -I_{0F}Z_0 = \frac{Z_2 Z_0 E_a}{Z_1 Z_2 + Z_1 Z_0 + Z_2 Z_0} \quad (45)$$

14. Two Lines Open—Fig. 21(p)

$$I_{1F} = I_{2F} = I_{0F} = \frac{E_a}{Z_1 + Z_2 + Z_0} \quad (46)$$

$$I_F = I_a = 3I_{0F} \quad (47)$$

$$E_{1x} - E_{1y} = E_a - I_{1F}Z_1 = \frac{E_a (Z_2 + Z_0)}{Z_1 + Z_2 + Z_0} \quad (48)$$

$$E_{2x} - E_{2y} = -I_{2F}Z_2 = -\frac{Z_2 E_a}{Z_1 + Z_2 + Z_0} \quad (49)$$

$$E_{0x} - E_{0y} = -I_{0F}Z_0 = -\frac{Z_0 E_a}{Z_1 + Z_2 + Z_0} \quad (50)$$

15. Impedance in One Line—Fig. 21(s)

$$I_{1F} = \frac{E_a (ZZ_0 + ZZ_2 + 3Z_1 Z_2 Z_0)}{ZZ_1 Z_0 + ZZ_1 Z_2 + 3Z_1 Z_2 Z_0 + ZZ_2 Z_0} \quad (51)$$

$$I_{2F} = -\frac{ZZ_0 E_a}{ZZ_1 Z_0 + ZZ_1 Z_2 + 3Z_1 Z_2 Z_0 + ZZ_2 Z_0} \quad (52)$$

$$I_{0F} = -\frac{ZZ_2 E_a}{ZZ_1 Z_0 + ZZ_1 Z_2 + 3Z_1 Z_2 Z_0 + ZZ_2 Z_0} \quad (53)$$

$$E_{1x} - E_{1y} = E_a - I_{1F}Z_1 = \frac{ZZ_2 Z_0 E_a}{ZZ_1 Z_0 + ZZ_1 Z_2 + 3Z_1 Z_2 Z_0 + ZZ_2 Z_0} \quad (54)$$

$$E_{2x} - E_{2y} = - \frac{ZZ_2Z_0E_{a1}}{I_2Z_2 + ZZ_1Z_0 + ZZ_1Z_2 + 3Z_1Z_2Z_0 + ZZ_2Z_0} \quad (55)$$

$$E_{0x} - E_{0y} = - \frac{ZZ_2Z_0E_{a1}}{I_0Z_0 = ZZ_1Z_0 + ZZ_1Z_2 + 3Z_1Z_2Z_0 + ZZ_2Z_0} \quad (56)$$

If two or more unbalances occur simultaneously, mutual coupling or connections will occur between the sequence networks at each point of unbalance, and if the unbalances are not symmetrical with respect to the same phase, the

connections will have to be made through phase-shifting transformers. The analysis in the cases of simultaneous faults is considerably more complicated than for single unbalances.

No assumptions were made in the derivation of the representation of the shunt and series unbalances of Fig. 21 that would not permit the application of the same principles to simultaneous faults on multiple unbalances. In fact various cases of single unbalance can be combined to

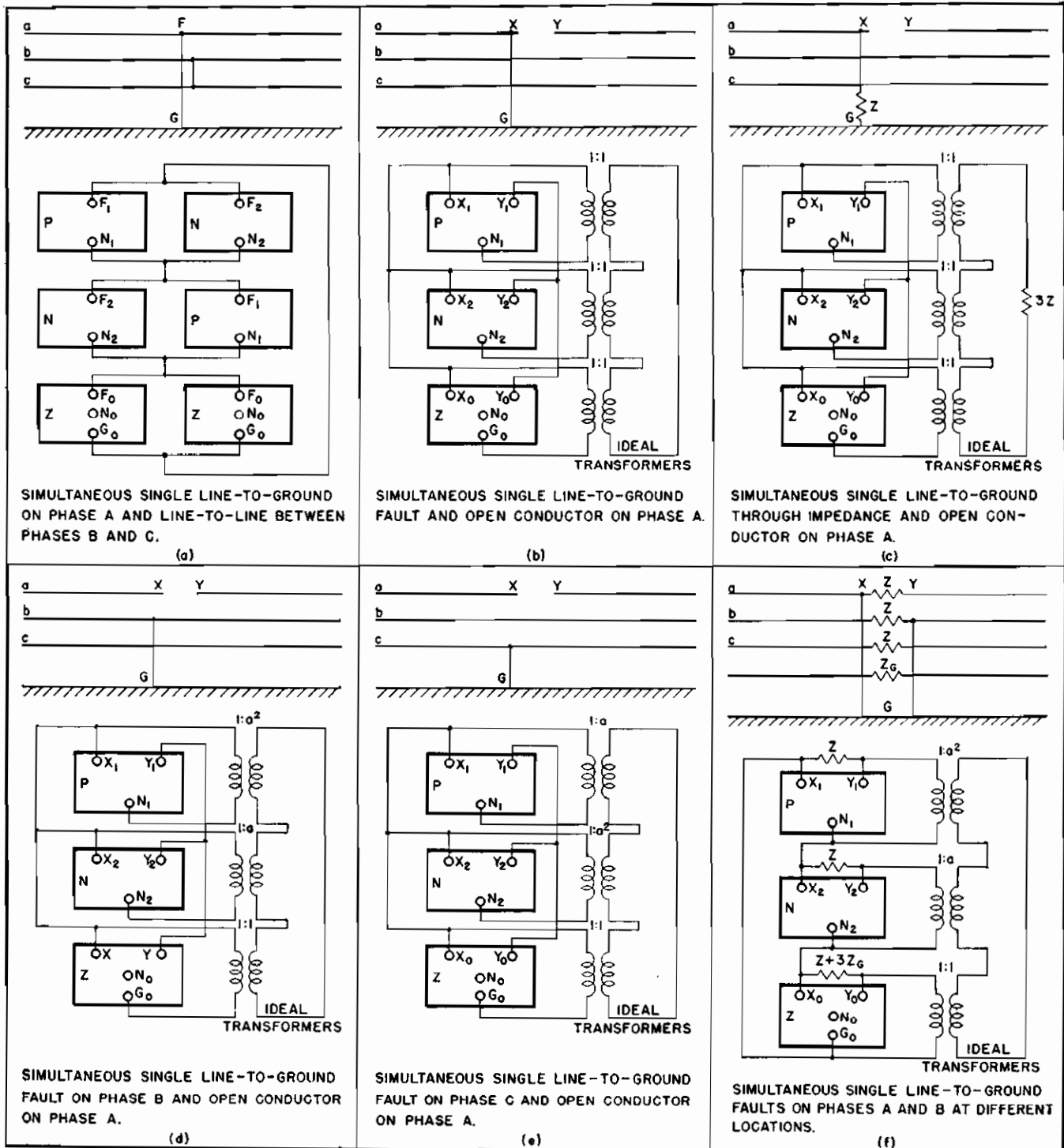

Fig. 22—Connections between the sequence networks for typical cases of multiple unbalances.

form the proper restraints or terminal connections to represent multiple unbalances. For example, the representation for a simultaneous single line-to-ground fault on phase "a" and a line-to-line fault on phases "b" and "c" can be derived by satisfying the terminal connections of Figs. 21(d) and 21(f). Fig. 21(d) dictates that the three networks be connected in series, while Fig. 21(f) shows the positive- and negative-sequence networks in parallel. Both of these requirements can be met simultaneously as shown in Fig. 22(a). Simultaneous faults that are not symmetrical to the reference phase can be represented by similar connections using ideal transformers or phase shifters to shift the sequence voltages and currents originating in all of the unbalances except the first or reference condition. The fault involving phase "a" is usually taken as the reference and all others are shifted by the proper amount before making the terminal connections required to satisfy that particular type of fault. The positive-, negative-, and zero-sequence shifts, respectively for an unbalance that is symmetrical to phase "a" are 1, 1, 1; "b" phase a^2 , a , 1; to "c" phase a , a^2 , 1. A few multiple unbalances that may occur at one point in a system simultaneously are given in Fig. 22, which also gives one illustration of simultaneous faults at different points in a system with one fault not symmetrical with respect to phase a.

To summarize, the procedure in finding voltages and currents throughout a system during fault conditions is: (1) set up each sequence network as viewed from the fault, (2) find the distribution factors for each sequence current throughout its network, (3) reduce the network to as simple a circuit as possible, (4) make the proper connection between the networks at the fault point to represent the unbalanced condition, (5) solve the resulting single-phase circuit for the sequence currents at the fault, (6) find the sequence components of voltage and current at the desired locations in the system. The positive-sequence voltage to be used, and the machine impedances, in step (5) depend upon when the fault currents and voltages are desired; if immediately after the fault occurs, in general, use subtransient reactances and the voltage back of subtransient reactance immediately preceding the fault; if a few cycles after the fault occurs, use transient reactances and the voltage back of transient reactance immediately before the fault; and if steady-state conditions are desired, use synchronous reactances and the voltage back of synchronous reactance. If regulators are used, normal bus voltage can be used to find steady-state conditions and the machine reactance in the positive-sequence network taken as being zero.

X. EXAMPLE OF FAULT CALCULATION

16. Problem

Let us assume the typical transmission system shown in Fig. 23(a) to have a single line-to-ground fault on one end of the 66 kv line as shown. The line construction is given in Fig. 23(b) and the generator constants in Fig. 23(c). Calculate the following:

- Positive-sequence reactance to the point of fault.
- Negative-sequence reactance to the point of fault.
- Zero-sequence reactance to the point of fault.

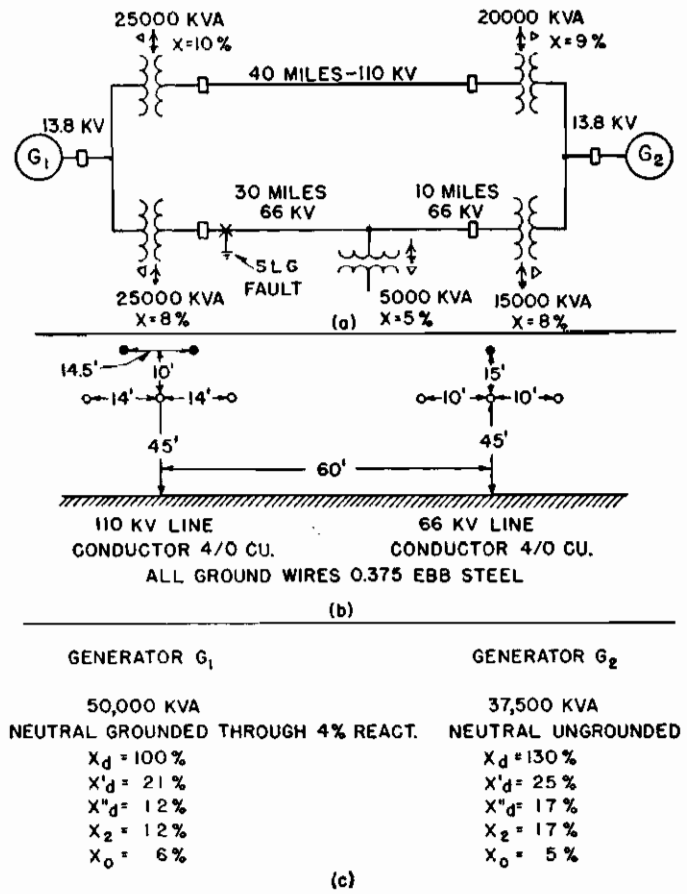

Fig. 23—Typical system assumed for fault calculation.

- System single-line diagram.
- Line construction.
- Tabulation of generator constants.
- Fault current.
- Line currents, line-to-ground voltages, and line-to-line voltages at the breaker adjacent to the fault.
- Line currents, line-to-ground voltages, and line-to-line voltages at the terminals of G' .
- Line currents, line-to-ground voltages, and line-to-line voltages at the 110 kv breaker adjacent to the 25,000 kva transformer.

17. Assumptions

- That the fault currents are to be calculated using transient reactances.
- A base of 50,000 kva for the calculations.
- That all resistances can be neglected.
- That a voltage, positive-sequence, as viewed from the fault of $j 100\%$ will be used for reference. This is an assumed voltage of $j \frac{66,000}{\sqrt{3}}$ volts between line "a" and neutral.
- That the reference phases on either side of the star-delta transformers are chosen such that positive-sequence voltage on the high side is advanced 30° in phase position from the positive-sequence voltage on the low side of the transformer.

18. Line Reactances (Refer to Chap. 3)

Positive- and Negative-Sequence Reactances of the 110 kv Line.

For 4/0 copper conductors $x_a = 0.497$ ohms per mile.
 $x_d = \frac{1}{3}(x_d \text{ for 14 feet} + x_d \text{ for 14 feet} + x_d \text{ for 28 feet}).$
 $= \frac{1}{3}(0.320 + 0.320 + 0.404) = 0.348$ ohms per mile.
 $x_1 = x_2 = x_a + x_d = 0.497 + 0.348 = 0.845$ ohms per mile.

Positive- and Negative-Sequence Reactances of the 66 kv Line.

$x_a = 0.497$ ohms per mile.
 $x_d = \frac{1}{3}(x_d \text{ for 10 feet} + x_d \text{ for 10 feet} + x_d \text{ for 20 feet}).$
 $= \frac{1}{3}(0.279 + 0.279 + 0.364) = 0.307$ ohms per mile.
 $x_1 = x_2 = x_a + x_d = 0.497 + 0.307 = 0.804$ ohms per mile.

Zero-Sequence Reactances—Since zero-sequence currents flowing in either the 110- or the 66-kv line will induce a zero-sequence voltage in the other line and in all three ground wires, the zero-sequence mutual reactances between lines, between each line and the two sets of ground wires, and between the two sets of ground wires, must be evaluated as well as the zero-sequence self reactances. Indeed, the zero-sequence self reactance of either the 110- or the 66-kv line will be affected by the mutual coupling existing with all of the ground wires. The three conductors of the 110-kv line, with ground return, are assumed to form one zero-sequence circuit, denoted by “a” in Fig. 24; the two ground conductors for this line, with ground return, form the zero-sequence circuit denoted “g”; the three conductors for the 66-kv line, with ground return, form the zero-sequence circuit denoted “a’”; and the single ground wire for the 66-kv line, with ground return, forms the zero-sequence circuit denoted “g’.” Although not strictly correct, we assume the currents carried by the two ground wires of circuit “g” are equal. Then let:

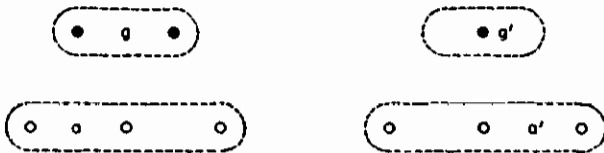

Fig. 24—Zero-sequence circuits formed by the 110 kv line (a), the 66 kv line (a’), the two ground wires (g), and the single ground wire (g’).

- E_0 = zero-sequence voltage of circuit a
- E_{g0} = zero-sequence voltage of circuit g = 0, since the ground wires are assumed to be continuously grounded.
- E'_0 = zero-sequence voltage of circuit a’
- E'_{g0} = zero-sequence voltage of circuit g’ = 0, since the ground wire is assumed to be continuously grounded.
- I_0 = zero-sequence current of circuit a
- I_g = zero-sequence current of circuit g
- I'_0 = zero-sequence current of circuit a’
- I'_g = zero-sequence current of circuit g’

It should be remembered that unit I_0 is one ampere in each of the three line conductors with three amperes re-

turning in ground; unit I_g is 3/2 amperes in each of the two ground wires with three amperes returning in the ground; unit I'_0 is one ampere in each of the three line conductors with three amperes returning in the ground; and unit I'_g is three amperes in the ground wire with three amperes returning in the ground.

These quantities are inter-related as follows:

$$\begin{aligned} E_0 &= I_0 Z_{0(a)} + I_g Z_{0(ag)} + I'_0 Z_{0(aa')} + I'_g Z_{0(ag')} \\ E_{g0} &= I_0 Z_{0(ag)} + I_g Z_{0(gg)} + I'_0 Z_{0(a'g)} + I'_g Z_{0(gg')} = 0 \\ E'_0 &= I_0 Z_{0(aa')} + I_g Z_{0(a'g)} + I'_0 Z_{0(a'a')} + I'_g Z_{0(a'g')} \\ E'_{g0} &= I_0 Z_{0(a'g')} + I_g Z_{0(gg')} + I'_0 Z_{0(a'g')} + I'_g Z_{0(g'g')} = 0 \end{aligned}$$

where

$$\begin{aligned} Z_{0(a)} &= \text{zero-sequence self reactance of the a circuit} \\ &= x_a + x_c - \frac{2}{3}(x_d \text{ for 14 feet} + x_d \text{ for 14 feet} + x_d \text{ for 28 feet}) \\ &= 0.497 + 2.89 - 2(0.348) = 2.69 \text{ ohms per mile.} \end{aligned}$$

$$\begin{aligned} Z_{0(a')} &= \text{zero-sequence self reactance of the a' circuit} \\ &= x_a + x_c - \frac{2}{3}(x_d \text{ for 10 feet} + x_d \text{ for 10 feet} + x_d \text{ for 20 feet}) \\ &= 0.497 + 2.89 - 2(0.307) = 2.77 \text{ ohms per mile.} \end{aligned}$$

$$\begin{aligned} Z_{0(g)} &= \text{zero-sequence self reactance of the g circuit} \\ &= \frac{2}{3}x_a + x_c - \frac{2}{3}(x_d \text{ for 14.5 feet}) \\ &= \frac{2}{3}(2.79) + 2.89 - \frac{2}{3}(0.324) = 6.59 \text{ ohms per mile.} \end{aligned}$$

$$\begin{aligned} Z_{0(g')} &= \text{zero-sequence self reactance of the g' circuit} \\ &= 3x_a + x_c \\ &= 3(2.79) + 2.89 = 11.26 \text{ ohms per mile.} \end{aligned}$$

$$\begin{aligned} Z_{0(ag)} &= \text{zero-sequence mutual reactance between the a and g circuits} \\ &= x_c - \frac{2}{3}(x_d \text{ for 12.06 feet} + x_d \text{ for 12.06 feet} + x_d \text{ for 12.35 feet} + x_d \text{ for 12.35 feet} + x_d \text{ for 23.5 feet} + x_d \text{ for 23.5 feet}) \\ &= 2.89 - 3(0.3303) = 1.90 \text{ ohms per mile.} \end{aligned}$$

$$\begin{aligned} Z_{0(aa')} &= \text{zero-sequence mutual reactance between the a and a' circuits} \\ &= x_c - \frac{2}{3}(x_d \text{ for 60 feet} + x_d \text{ for 50 feet} + x_d \text{ for 70 feet} + x_d \text{ for 46 feet} + x_d \text{ for 36 feet} + x_d \text{ for 56 feet} + x_d \text{ for 74 feet} + x_d \text{ for 64 feet} + x_d \text{ for 84 feet}) \\ &= 2.89 - 3(0.493) = 1.411 \text{ ohms per mile.} \end{aligned}$$

$$\begin{aligned} Z_{0(ag')} &= \text{zero-sequence mutual reactance between the a and g' circuits.} \\ &= x_c - \frac{2}{3}(x_d \text{ for 75 feet} + x_d \text{ for 62 feet} + x_d \text{ for 48 feet}) \\ &= 2.89 - 3(0.498) = 1.40 \text{ ohms per mile.} \end{aligned}$$

$$\begin{aligned} Z_{0(a'g')} &= \text{zero-sequence mutual reactance between the a' and g' circuits.} \\ &= x_c - \frac{2}{3}(x_d \text{ for 15 feet} + x_d \text{ for 18.03 feet} + x_d \text{ for 18.03 feet}) \\ &= 2.89 - 3(0.344) = 1.86 \text{ ohms per mile.} \end{aligned}$$

Similar definitions apply for $Z_{0(a'g)}$ and $Z_{0(gg')}$. In each case the zero-sequence mutual reactance between two circuits is equal to x_c minus three times the average of the x_d 's for all possible distances between conductors of the two circuits.

The zero-sequence self reactance of the 110-kv line in the presence of all zero-sequence circuits is obtained by

letting I_0' be zero in the above equations and solving for $\frac{E_0}{I_0}$. Carrying out this rather tedious process, it will be found that

$$\frac{E_0}{I_0} = 2.05 \text{ ohms per mile.}$$

The zero-sequence self reactance of the 66-kv line in the presence of all zero-sequence circuits is obtained by letting I_0 be zero in the equations and solving for $\frac{E_0'}{I_0'}$. It will be found that

$$\frac{E_0'}{I_0'} = 2.25 \text{ ohms per mile.}$$

The zero-sequence mutual reactance between the 66- and the 110-kv line in the presence of all zero-sequence

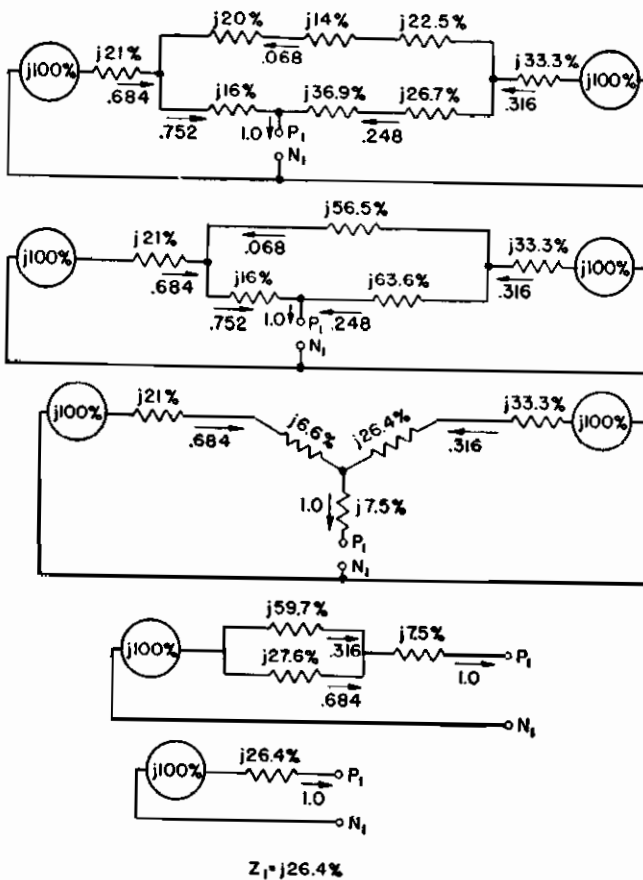

Fig. 25—Reduction of the positive-sequence network and the positive-sequence distribution factors.

circuits is obtained by letting I_0' be zero and solving for $\frac{E_0'}{I_0}$. When this is done, it will be found that $\frac{E_0'}{I_0}$ (with $I_0' = 0$) = $\frac{E_0}{I_0}$ (with $I_0 = 0$) = 0.87 ohms per mile.

19. The Sequence Networks

The sequence networks are shown in Figs. 25, 26, and 27, with all reactances expressed in percent on a 50 000-

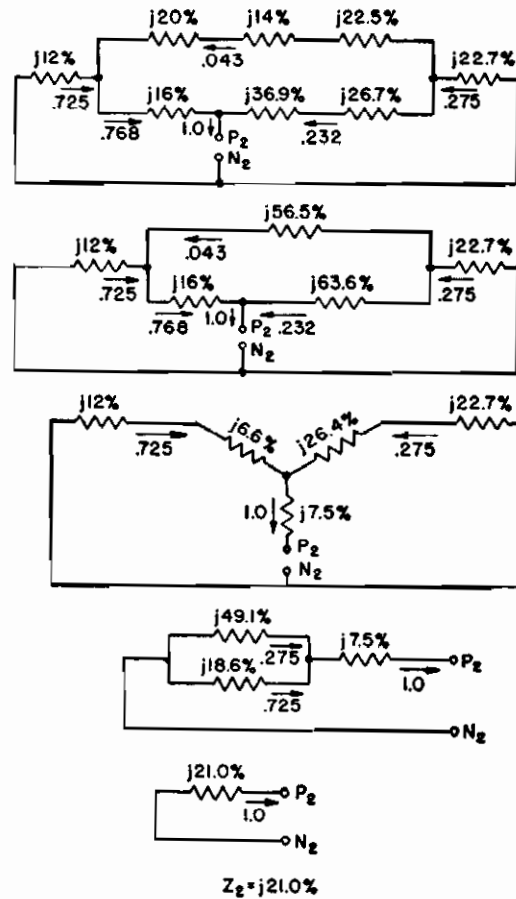

Fig. 26—Reduction of the negative-sequence network and the negative sequence distribution factors.

kva base and the networks set up as viewed from the fault. Illustrative examples of expressing these reactances in percent on a 50 000-kva base follow:

Positive-sequence reactance of G_2 =

$$(25) \frac{(50\ 000)}{(37\ 500)} = 33.3\%$$

Positive-sequence reactance of the 66-kv line =

$$\frac{(0.804) (40) (50\ 000)}{(66) (66) (10)} = 36.9\%$$

Positive-sequence reactance of the 110-kv line =

$$\frac{(0.845) (40) (50\ 000)}{(110) (110) (10)} = 14\%$$

Zero-sequence mutual reactance between the 66- and the 110-kv line for the 30 mile section =

$$\frac{(0.87) (30) (50\ 000)}{(110) (66) (10)} = 18\%$$

The distribution factors are shown on each sequence network; obtained by finding the distribution of one ampere taken as flowing out at the fault.

Each network is finally reduced to one equivalent impedance as viewed from the fault.

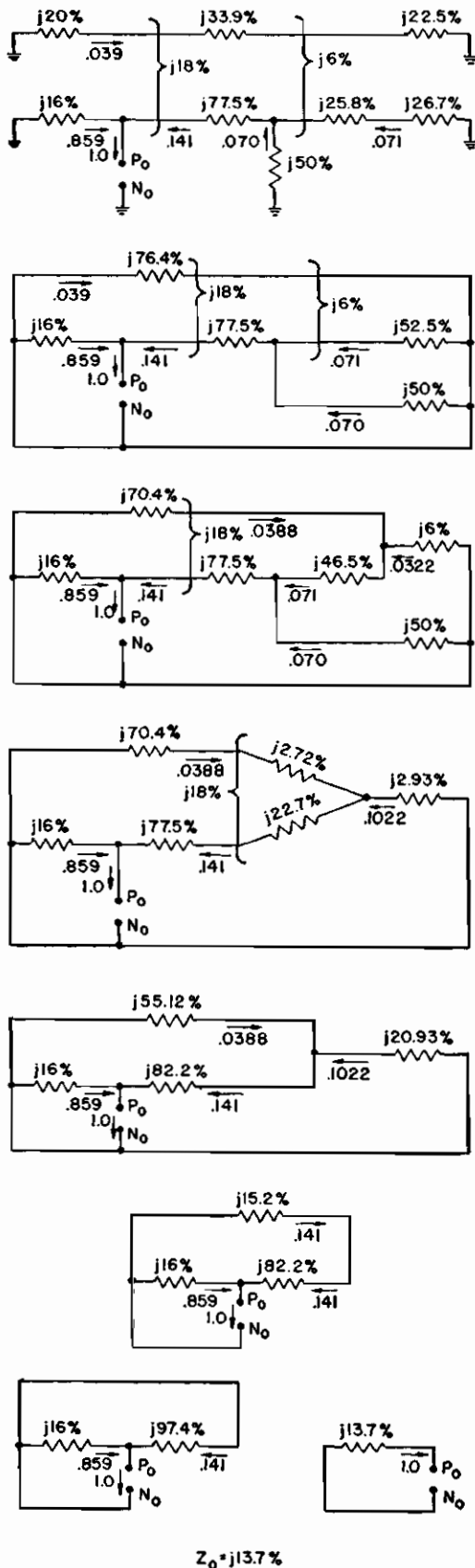

Fig. 27—Reduction of the zero-sequence network and the zero-sequence distribution factors.

20. Voltages and Currents at the Fault

The sequence networks are connected in series to represent a single line-to-ground fault. The total reactance of the resulting single-phase network is

$$Z_1\% + Z_2\% + Z_0\% = 26.4\% + 21.0\% + 13.7\% = 61.1\%.$$

Then: $I_{0F} = I_{1F} = I_{2F} = \frac{j100\%}{j61.1\%} = 1.637 \text{ p.u.}$

Since normal current for the 66-kv circuit (for a base kva of 50 000)

$$= \frac{50\,000}{\sqrt{3} \times 66} = 437.5 \text{ amperes.}$$

$$I_0 = I_1 = I_2 = (1.637)(437.5) = 715 \text{ amperes.}$$

The total fault current =

$$I_0 + I_1 + I_2 = 4.911 \text{ p.u.} = 2145 \text{ amperes.}$$

The sequence voltages at the fault:

$$E_1 = E_{a1} - I_1 Z_1 = j100\% - j(1.637)(26.4)\% = j56.9\% = j21\,700 \text{ volts.}$$

$$E_2 = -I_2 Z_2 = -j(1.637)(21)\% = -j34.4\% = -j13\,100 \text{ volts.}$$

$$E_0 = -I_0 Z_0 = -j(1.637)(13.7)\% = -j22.5\% = -j8\,600 \text{ volts.}$$

$$E_{ag} = E_0 + E_1 + E_2 = 0$$

$$E_{bg} = E_0 + a^2 E_1 + a E_2 = 30\,200 - j12\,900 = 32\,800 \text{ volts.}$$

$$E_{cg} = E_0 + a E_1 + a^2 E_2 = -30\,200 - j12\,900 = 32\,800 \text{ volts.}$$

$$E_{ab} = E_{ag} - E_{bg} = -30\,200 + j12\,900 = 32\,800 \text{ volts.}$$

$$E_{bc} = E_{bg} - E_{cg} = 60\,400 \text{ volts.}$$

$$E_{ca} = E_{cg} - E_{ag} = -30\,200 - j12\,900 = 32\,800 \text{ volts.}$$

21. Voltages and Currents at the Breaker Adjacent to the Fault

Using the distribution factors in the sequence networks at this point:

$$I_1 = (0.752)(1.637) = 1.231 \text{ p.u.} = 540 \text{ amperes.}$$

$$I_2 = (0.768)(1.637) = 1.258 \text{ p.u.} = 550 \text{ amperes.}$$

$$I_0 = (0.859)(1.637) = 1.407 \text{ p.u.} = 615 \text{ amperes.}$$

$$I_a = I_0 + I_1 + I_2 = 1705 \text{ amperes.}$$

$$I_b = I_0 + a^2 I_1 + a I_2 = 70 + j8.6 = 70.5 \text{ amperes.}$$

$$I_c = I_0 + a I_1 + a^2 I_2 = 70 - j8.6 = 70.5 \text{ amperes.}$$

The line-to-ground and line-to-line voltages at this point are equal to those calculated for the fault.

22. Voltages and Currents at the Breaker Adjacent to Generator G₁

The base, or normal, voltage at this point is 13 800 volts line-to-line, or 7960 volts line-to-neutral.

The base, or normal, current at this point is $\frac{50\,000}{\sqrt{3} \times 13.8} = 2090$ amperes. Since a star-delta transformation is involved, there will be a phase shift in positive- and negative-sequence quantities.

$$I_1 = (0.684)(1.637)(2090)\epsilon^{-j30} = 2340 \text{ amperes} = 2030 - j1170.$$

$$I_2 = (0.725)(1.637)(2090)\epsilon^{+j30} = 2480 \text{ amperes} = 2150 + j1240.$$

$$I_0 = 0.$$

$$I_a = I_0 + I_1 + I_2 = 4180 + j70 = 4180 \text{ amperes.}$$

$$I_b = I_0 + a^2 I_1 + a I_2 = -4180 + j70 = 4180 \text{ amperes.}$$

$$I_c = I_0 + a I_1 + a^2 I_2 = -j140 = 140 \text{ amperes.}$$

The sequence voltages at this point are:

$$E_1 = (j100\% - j0.684 \times 21 \times 1.637\%) \epsilon^{-j30} = -a^2 76.5\% \\ = 3045 + j5270 \text{ volts.}$$

$$E_2 = (-j0.725 \times 12 \times 1.637\%) \epsilon^{j30} = -a 14.2\% \\ = 565 - j980 \text{ volts.}$$

$$E_0 = 0.$$

$$E_{ag} = E_1 + E_2 = 3610 + j4290 = 5600 \text{ volts.}$$

$$E_{bg} = a^2 E_1 + a E_2 = 3610 - j4290 = 5600 \text{ volts.}$$

$$E_{cg} = a E_1 + a^2 E_2 = -7220 = 7220 \text{ volts.}$$

$$E_{ab} = +j8580 = 8580 \text{ volts.}$$

$$E_{bc} = 10\,830 - j4290 = 11\,650 \text{ volts.}$$

$$E_{ca} = -10\,830 - j4290 = 11\,650 \text{ volts.}$$

$$I_b = I_0 + a^2 I_1 + a I_2 = 40.5 + j9.35 = 41.6 \text{ amperes.}$$

$$I_c = I_0 + a I_1 + a^2 I_2 = 40.5 - j9.35 = 41.6 \text{ amperes.}$$

The sequence voltages at this point are:

$$E_1 = j100\% - j(0.684)(1.637)(21)\% \\ - j(-0.068)(1.637)(20)\% = j78.7\% \\ = j50\,000 \text{ volts.}$$

$$E_2 = -j(0.725)(1.637)(12)\% \\ - j(-0.043)(1.637)(20)\% = -j12.8\% \\ = -j8130 \text{ volts.}$$

$$E_0 = -j(0.039)(1.637)(20)\% = -j1.3\% = -j825 \text{ volts.}$$

$$E_{ag} = E_0 + E_1 + E_2 = j41\,000 = 41\,000 \text{ volts.}$$

$$E_{bg} = E_0 + a^2 E_1 + a E_2 = 50\,300 - j21\,750 = 54\,800 \text{ volts.}$$

$$E_{cg} = E_0 + a E_1 + a^2 E_2 = -50\,300 - j21\,750 = 54\,800 \text{ volts.}$$

$$E_{ab} = -50\,300 + j62\,750 = 80\,400 \text{ volts.}$$

$$E_{bc} = 100\,600 = 100\,600 \text{ volts.}$$

$$E_{ca} = -50\,300 - j62\,750 = 80\,400 \text{ volts.}$$

23. Voltages and Currents at the 110-kv Breaker Adjacent to the 25 000 kva Transformer

The base, or normal, voltage at this point is 110 000 volts line-to-line; or 63 500 volts line-to-neutral.

The base, or normal, current at this point is $\frac{50\,000}{\sqrt{3} \times 110}$
= 262 amperes.

The sequence currents at this point are:

$$I_1 = (-0.068)(1.637)(262) = -29.2 \text{ amperes.}$$

$$I_2 = (-0.043)(1.637)(262) = -18.4 \text{ amperes.}$$

$$I_0 = (0.039)(1.637)(262) = 16.7 \text{ amperes.}$$

$$I_a = I_0 + I_1 + I_2 = -30.9 = 30.9 \text{ amperes.}$$

REFERENCES

1. Method of Symmetrical Coordinates Applied to the Solution of Polyphase Networks, by C. L. Fortescue, *A.I.E.E. Transactions*, V. 37, Part II, 1918, pp. 1027-1140.
2. *Symmetrical Components* (a book), by C. F. Wagner and R. D. Evans, McGraw-Hill Book Company, 1933.
3. Sequence Network Connections for Unbalanced Load and Fault Conditions, by E. L. Harder, *The Electric Journal*, V. 34, December 1937, pp. 481-488.
4. Simultaneous Faults on Three-Phase Systems, by Edith Clarke, *A.I.E.E. Transactions*, V. 50, March 1931, pp. 919-941.
5. *Applications of Symmetrical Components* (a book) by W. V. Lyon, McGraw-Hill Book Company, 1937.

CHAPTER 3

CHARACTERISTICS OF AERIAL LINES

Original Authors:

Sherwin H. Wright and C. F. Hall

Revised by:

D. F. Shankle and R. L. Tremaine

IN the design, operation, and expansion of electrical power systems it is necessary to know electrical and physical characteristics of conductors used in the construction of aerial distribution and transmission lines.

This chapter presents a description of the common types of conductors along with tabulations of their important electrical and physical characteristics. General formulas are presented with their derivation to show the basis of the tabulated values and as a guide in calculating data for other conductors of similar shapes, dimensions, composition and operating conditions.

Also included are the more commonly used symmetrical-component-sequence impedance equations that are applicable to the solution of power system problems involving voltage regulation, load flow, stability, system currents, and voltages under fault conditions, or other system problems where the electrical characteristics of aerial lines are involved.

Additional formulas are given to permit calculation of approximate current-carrying capacity of conductors taking into account such factors as convection and radiation losses as influenced by ambient temperature, wind velocity, and permissible temperature rise.

I. TYPES OF CONDUCTORS

In the electric-power field the following types of conductors are generally used for high-voltage power transmission lines: stranded copper conductors, hollow copper conductors, and ACSR (aluminum cable, steel reinforced).

Other types of conductors such as Copperweld and Copperweld-Copper conductors are also used for transmission and distribution lines. Use is made of Copperweld, bronze, copper bronze, and steel for current-carrying conductors on rural lines, as overhead ground wires for transmission lines, as buried counterpoises at the base of transmission towers, and also for long river crossings.

A stranded conductor, typical of both copper and steel conductors in the larger sizes, is shown in Fig. 1. A stranded conductor is easier to handle and is more flexible than a solid conductor, particularly in the larger sizes.

A typical ACSR conductor is illustrated in Fig. 2. In this type of conductor, aluminum strands are wound about a core of stranded steel. Varying relationships between tensile strength and current-carrying capacity as well as overall size of conductor can be obtained by varying the proportions of steel and aluminum. By the use of a filler, such as paper, between the outer aluminum strands and the inner steel strands, a conductor of large diameter can be obtained for use in high voltage lines. This type of con-



Courtesy of General Cable Corporation

Fig. 1—A typical stranded conductor, (bare copper).

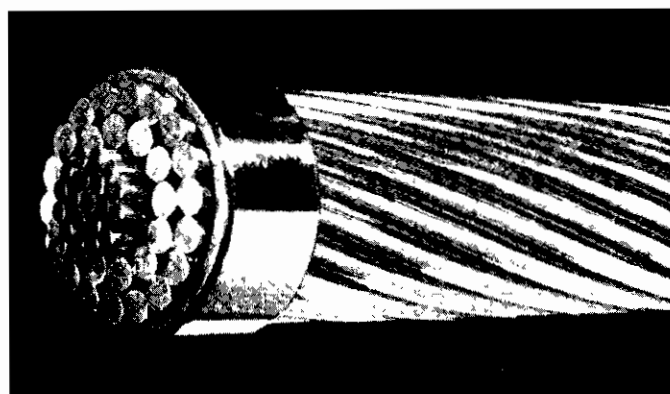

Courtesy of Aluminum Company of America

Fig. 2—A typical ACSR conductor.

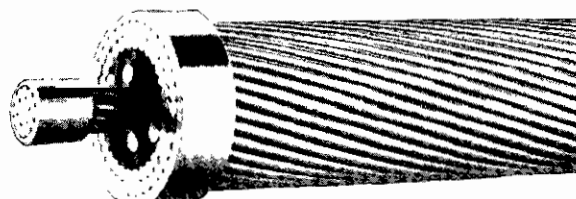

Courtesy of Aluminum Company of America

Fig. 3—A typical "expanded" ACSR conductor.

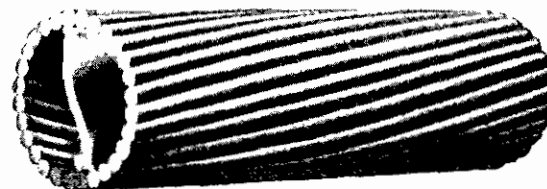

Courtesy of Anaconda Wire and Cable Company

Fig. 4—A typical Anaconda Hollow Copper Conductor.

ductor is known as "expanded" ACSR and is shown in Fig. 3.

In Fig. 4 is shown a representative Anaconda Hollow Copper Conductor. It consists of a twisted copper "I"

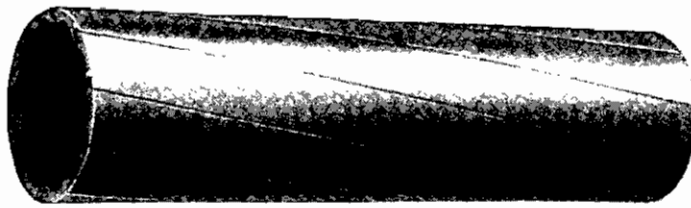

Courtesy of General Cable Corporation

Fig. 5—A typical General Cable Type HH.



Courtesy of Copperweld Steel Company

Fig. 6—A typical Copperweld conductor.



Courtesy of Copperweld Steel Company

Fig. 7—Typical Copperweld-Copper conductors

- (a) Upper photograph—Type V
 (b) Lower photograph—Type F

beam as a core about which strands of copper wire are wound. The "I" beam is twisted in a direction opposite to that of the inner layer of strands.

Another form of hollow copper conductor is shown in Fig. 5. Known as the General Cable Type HH hollow copper conductor, it is made up of segmental sections of copper mortised into each other to form a self-supporting hollow cylinder. Hollow copper conductors result in conductors of large diameter for a given cross section of copper. Corona losses are therefore smaller. This construction also produces a reduction in skin effect as well as inductance as compared with stranded conductors. A discussion of large diameter conductors and their characteristics is given in reference 1.

Copperweld conductors consist of different numbers of copper-coated steel strands, a typical conductor being illustrated in Fig. 6. Strength is provided by the core of steel and protection by the outer coating of copper.

When high current-carrying capacities are desired as well as high tensile strength, copper strands are used with Copperweld strands to form Copperweld-Copper conduct-

ors as shown in Fig. 7. Different relationships between current-carrying capacity, outside diameter, and tensile strength can be obtained by varying the number and size of the Copperweld and copper strands.

II. ELECTRICAL CHARACTERISTICS OF AERIAL CONDUCTORS

The following discussion is primarily concerned with the development of electrical characteristics and constants of aerial conductors, particularly those required for analysis of power-system problems. The constants developed are particularly useful in the application of the principles of symmetrical components to the solution of power-system problems involving positive-, negative-, and zero-sequence impedances of transmission and distribution lines. The basic quantities needed are the positive-, negative-, and zero-sequence resistances, inductive reactances and shunt capacitive reactances of the various types of conductors and some general equations showing how these quantities are used.

1. Positive- and Negative-Sequence Resistance

The resistance of an aerial conductor is affected by the three factors: temperature, frequency, current density. Practical formulas and methods will now be given to take into account these factors.

Temperature Effect on Resistance—The resistance of copper and aluminum conductors varies almost directly with temperature. While this variation is not strictly linear for an extremely wide range of temperatures, for practical purposes it can be considered linear over the range of temperatures normally encountered.

When the d-c resistance of a conductor at a given temperature is known and it is desired to find the d-c resistance at some other temperature, the following general formula may be used.

$$\frac{R_{t_2}}{R_{t_1}} = \frac{M + t_2}{M + t_1} \quad (1)$$

where

R_{t_2} = d-c resistance at any temperature t_2 degree C.

R_{t_1} = d-c resistance at any other temperature t_1 degree C.

M = a constant for any one type of conductor material.
 = inferred absolute zero temperature.

= 234.5 for annealed 100 percent conductivity copper.

= 241.5 for hard drawn 97.3 percent conductivity copper.

= 228.1 for aluminum.

The above formula is useful for evaluating changes in d-c resistance only, and cannot be used to give a-c resistance variations unless skin effect can be neglected. For small conductor sizes the frequency has a negligible effect on resistance in the d-c to 60-cycle range. This is generally true for conductor sizes up to 2/0.

The variations of resistance with temperature are usually unimportant because the actual ambient temperature is indefinite as well as variable along a transmission line. An illustration of percentage change in resistance is when temperature varies from winter to summer over a range of 0 degree C to 40 degrees C (32 degrees F to 104 degrees F) in which case copper resistance increases 17 percent.

Skin Effect in Straight Round Wires—The resistance of non-magnetic conductors varies not only with temperature but also with frequency. This is due to skin effect. Skin effect is due to the current flowing nearer the outer surface of the conductor as a result of non-uniform flux distribution in the conductor. This increases the resistance of the conductor by reducing the effective cross section of the conductor through which the current flows.

The conductor tables give the resistance at commercial frequencies of 25, 50, and 60 cycles. For other frequencies the following formula should be used.

$$r_t = Kr_{dc} \text{ ohms per mile} \tag{2}$$

where

r_t = the a-c resistance at the desired frequency (cycles per second).

r_{dc} = d-c resistance at any known temperature.

K = value given in Table 5.

In Table 5, K is given as a function of X , where

$$X = .063598 \sqrt{\frac{\mu f}{r_{\text{mile}}}} \tag{3}$$

f = frequency in cycles per second.

μ = permeability = 1.0 for non-magnetic materials.

r_{mile} = d-c resistance of the conductor in ohms per mile.

Table 5 (skin effect table) is carried in the Bureau of Standards Bulletin No. 169 on pages 226-8, to values of $X = 100$. To facilitate interpolation over a small range of the table, it is accurate as well as convenient to plot a curve of the values of K vs. values of X .

Combined Skin Effect and Temperature Effect on Resistance of Straight Round Wires—When both temperature and skin effect are considered in determining conductor resistance, the following procedure is followed.

First calculate the d-c resistance at the new temperature using Eq. (1). Then substitute this new value of d-c resistance and the desired frequency in the equation defining X . Having calculated X , determine K from Table 5. Then using Eq. (2), calculate the new a-c resistance r_t , using the new d-c resistance for r_{dc} and the value of K obtained from Table 5.

Effect of Current on Resistance—The resistance of magnetic conductors varies with current magnitude as well as with the factors that affect non-magnetic conductors (temperature and frequency).

Current magnitude determines the flux and therefore the iron or magnetic losses inside magnetic conductors. The presence of this additional factor complicates the determination of resistance of magnetic conductors as well as any tabulation of such data. For these reasons the effect of current magnitude will not be analyzed in detail. However, Fig. 8 gives the resistance of steel conductors as a function of current, and the tables on magnetic conductors such as Copperweld-copper, Copperweld, and ACSR conductors include resistance tabulations at two current carrying levels to show this effect. These tabulated resistances are generally values obtained by tests.

Zero-Sequence Resistance—The zero-sequence resistance of aerial conductors is discussed in detail in the section on zero-sequence resistance and inductive reactance given later in the chapter since the resistance and in-

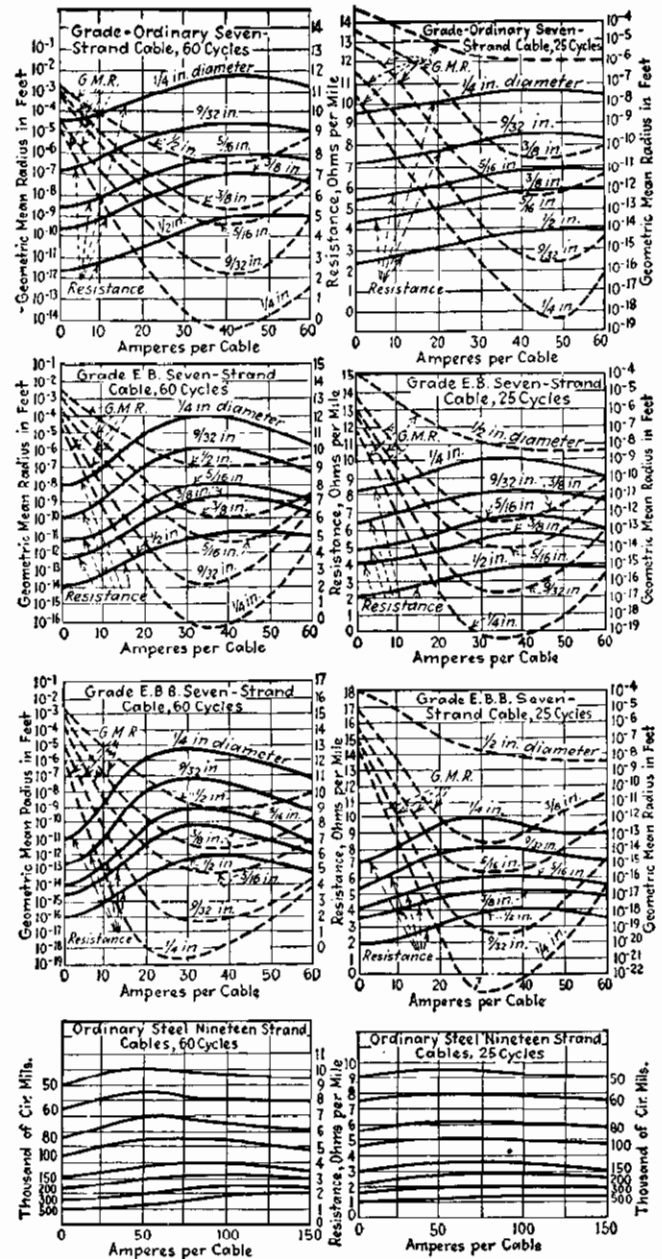

Fig. 8—Electrical Characteristics of Steel Ground Wires*

ductive reactance presented to zero-sequence currents is influenced by the distribution of the zero-sequence current in the earth return path.

2. Positive- and Negative-Sequence Inductive Reactance

To develop the positive- and negative-sequence inductive reactance of three-phase aerial lines it is first necessary to develop a few concepts that greatly simplify the problem.

First, the total inductive reactance of a conductor carrying current will be considered as the sum of two components:

*This figure has been taken from *Symmetrical Components* (a book) by C. F. Wagner and R. D. Evans, McGraw-Hill Book Company, 1933.

- (1) The inductive reactance due to the flux within a radius of one foot from the conductor center, including the flux inside the conductor.
- (2) The inductive reactance due to the flux external to a radius of one foot and out to some finite distance.

This concept was first given in Wagner and Evans book on Symmetrical Components² and was suggested by W. A. Lewis.⁴⁸

It can be shown most easily by considering a two-conductor single-phase circuit with the current flowing out in one conductor and returning in the other. In Fig. 9 such a circuit is shown with only the flux produced by conductor 1 for simplicity. Conductor 2 also produces similar lines of flux.

The classic inductance formula for a single round straight wire in the two-conductor single-phase circuit is:

$$L = \frac{\mu}{2} + 2 \ln \frac{D_{12}}{r} \text{ abhenries per cm. per conductor.} \quad (4)$$

where

- μ = permeability of conductor material.
- r = radius of conductor.

D_{12} = distance between conductor 1 and conductor 2.

D_{12} and r must be expressed in the same units for the above equation to be valid. For practical purposes one foot is used as the unit of length since most distances between aerial conductors are in feet. In cable circuits, however, the distance between conductors is less than one foot and the inch is a more common unit (see Chap. 4).

From derivation formulas a general term such as $2 \ln \frac{b}{a}$ represents the flux and associated inductance between circles of radius a and radius b surrounding a conductor carrying current. (See Fig. 10).

Rewriting Eq. (4) keeping in mind the significance of the general term $2 \ln \frac{b}{a}$,

$$L = \frac{\mu}{2} + 2 \ln \frac{1}{r} + 2 \ln \frac{D_{12}}{1} \text{ abhenries per cm. per conductor} \quad (5)$$

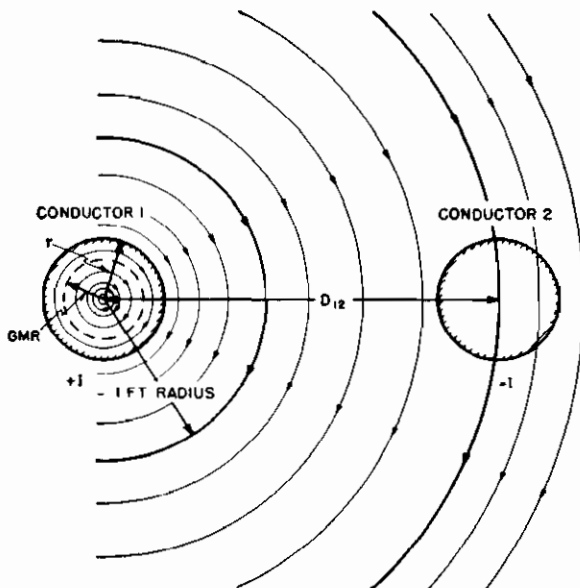

Fig. 9—A two conductor single phase circuit (inductance)

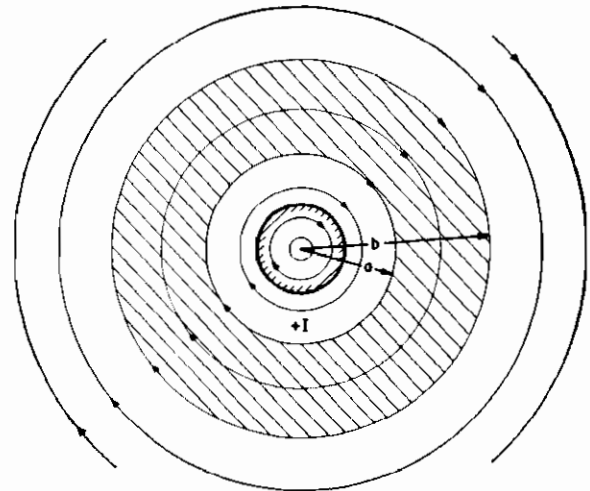

Fig. 10—Inductance due to flux between radius a and radius b ($2 \ln \frac{b}{a}$ abhenries per cm.)

where $\frac{\mu}{2}$ = inductance due to the flux inside the conductor.

$2 \ln \frac{1}{r}$ = inductance due to the flux outside the conductor to a radius of one foot.

$2 \ln \frac{D_{12}}{1}$ = inductance due to the flux external to a one foot radius out to D_{12} feet where D_{12} is the distance between conductor 1 and conductor 2.

From Fig. 9 it can be seen that it is unnecessary to include the flux beyond the return conductor 2 because this flux does not link any net current and therefore does not affect the inductance of conductor 1.

Grouping the terms in Eq. (5) we have:

$$L = \underbrace{\frac{\mu}{2} + 2 \ln \frac{1}{r}}_{L \text{ due to flux out to a one ft. radius}} + \underbrace{2 \ln \frac{D_{12}}{1}}_{L \text{ due to flux external to a 1 ft. radius out to } D_{12} \text{ ft.}} \text{ abhenries per cm. per conductor.} \quad (6)$$

Examining the terms in the first bracket, it is evident that this expression is the sum of the flux both inside the conductor ($\frac{\mu}{2}$) and that external to the conductor out to a radius of one foot ($2 \ln \frac{1}{r}$). Furthermore this expression contains terms that are strictly a function of the conductor characteristics of permeability and radius.

The term in the second bracket of Eq. (6) is an expression for inductance due to flux external to a radius of one foot and out to a distance of D_{12} , which, in the two-conductor case, is the distance between conductor 1 and conductor 2. This term is not dependent upon the conductor characteristics and is dependent only upon conductor spacing.

Equation (6) can be written again as follows:

$$L = 2 \ln \frac{1}{\text{GMR}} + 2 \ln \frac{D_{12}}{1} \text{ abhenries per cm. per conductor.} \quad (7)$$

GMR in the first term is the conductor "geometric mean radius". It can be defined as the radius of a tubular conductor with an infinitesimally thin wall that has the same external flux out to a radius of one foot as the internal and external flux of solid conductor 1, out to a radius of one foot. In other words, GMR is a mathematical radius assigned to a solid conductor (or other configuration such as stranded conductors), which describes in one term the inductance of the conductor due to both its internal flux ($\frac{\mu}{2}$) and the external flux out to a one foot radius ($2 \ln \frac{1}{r}$). GMR therefore makes it possible to replace the two terms ($\frac{\mu}{2} + 2 \ln \frac{1}{r}$) with one term ($2 \ln \frac{1}{\text{GMR}}$) which is entirely dependent upon the conductor characteristics. GMR is expressed in feet.

Converting Eq. (7) to practical units of inductive reactance,

$$x = 0.2794 \frac{f}{60} \log_{10} \frac{1}{\text{GMR}} + 0.2794 \frac{f}{60} \log_{10} \frac{D_{12}}{1} \text{ ohms per conductor per mile} \quad (8)$$

where f = frequency in cps.

GMR = conductor geometric mean radius in feet.

D_{12} = distance between conductors 1 and 2 in feet.

If we let the first term be called x_a and the second term x_d , then

$$x = x_a + x_d \text{ ohms per conductor per mile} \quad (9)$$

where

x_a = inductive reactance due to both the internal flux and that external to conductor 1 to a radius of one foot.

x_d = inductive reactance due to the flux surrounding conductor 1 from a radius of one foot out to a radius of D_{12} feet.

For the two-conductor, single-phase circuit, then, the total inductive reactance is

$$x = 2(x_a + x_d) \text{ ohms per mile of circuit} \quad (10)$$

since the circuit has two conductors, or both a "go" and "return" conductor.

Sometimes a tabulated or experimental reactance with 1 foot spacing is known, and from this it is desired to calculate the conductor GMR. By derivation from Eq. (8)

$$\text{GMR} = \frac{1}{\text{Antilog}_{10} \frac{\text{Reactance with 1 ft spacing (60 cycles)}}{0.2794}} \text{ feet.} \quad (11)$$

When reactance is known not to a one-foot radius but out to the conductor surface, it is called the "internal reactance." The formula for calculating the GMR from the "internal reactance" is:

$$\text{GMR} = \frac{\text{physical radius}}{\text{Antilog}_{10} \frac{\text{"Internal Reactance" (60 cycles)}}{0.2794}} \text{ feet} \quad (12)$$

The values of GMR at 60 cycles and x_a at 25, 50, and 60 cycles for each type of conductor are given in the tables of electrical characteristics of conductors. They are given

Solid round conductor.....	0.779a
Full stranding	
7.....	0.726a
19.....	0.758a
38.....	0.768a
61.....	0.772a
91.....	0.774a
127.....	0.776a
Hollow stranded conductors and A.C.S.R.	
(neglecting steel strands)	
30-two layer.....	0.826a
26-two layer.....	0.809a
54-three layer.....	0.810a
Single layer A.C.S.R.....	0.35a-070a
Point within circle.....	a
Point outside circle to circle.....	distance to center of circle
Rectangular section of sides α and β	0.2235($\alpha + \beta$)

CIRCULAR TUBE

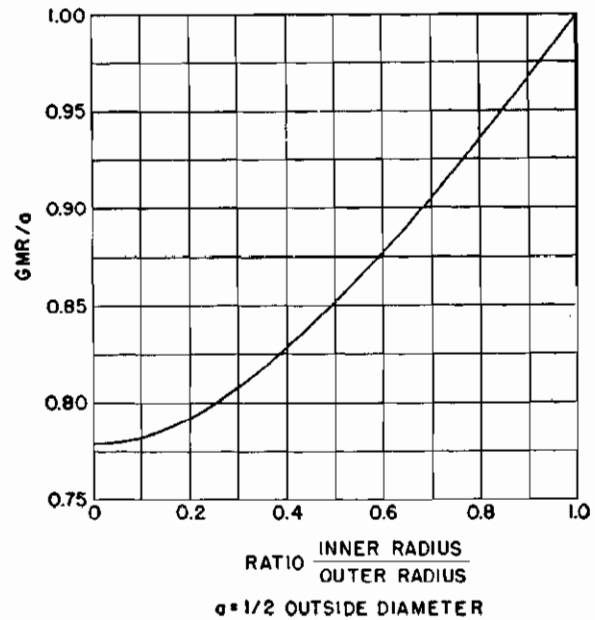

Fig. 11—Geometric Mean Radii and Distances.

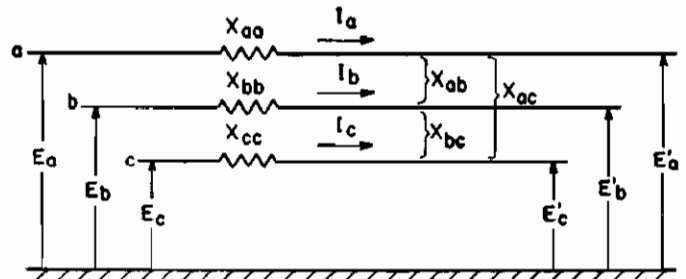
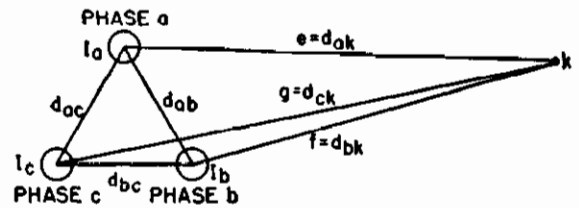

Fig. 12—A Three-conductor three-phase circuit (symmetrical spacing).

in these tables because they are a function of conductor characteristics of radius and permeability. Values of x_d for various spacings are given in separate tables in this Chapter for 25, 50, and 60 cycles. This factor is dependent on distance between conductors only, and is not associated with the conductor characteristics in any way.

In addition to the GMR given in the conductor characteristics tables, it is sometimes necessary to determine this quantity for other conductor configurations. Figure 11 is given for convenience in determining such values of GMR. This table is taken from the Wagner and Evans book *Symmetrical Components*, page 138.

Having developed x_a and x_d in terms of a two-conductor, single-phase circuit, these quantities can be used to determine the positive- and negative-sequence inductive reactance of a three-conductor, three-phase circuit.

Figure 12 shows a three-conductor, three-phase circuit carrying phase currents I_a , I_b , I_c produced by line to ground voltages E_a , E_b , and E_c . First, consider the case where the three conductors are symmetrically spaced in a triangular configuration so that no transpositions are required to maintain equal voltage drops in each phase along the line. Assume that the three-phase voltages E_a , E_b , E_c are balanced (equal in magnitude and 120° apart) so that they may be either positive- or negative-sequence voltages. Also assume the currents I_a , I_b , I_c are also balanced so that $I_a + I_b + I_c = 0$. Therefore no return current flows in the earth, which practically eliminates mutual effects between the conductors and earth, and the currents I_a , I_b , I_c can be considered as positive- or negative-sequence currents. In the following solution, positive- or negative-sequence voltages E_a , E_b , E_c , are applied to the conductors and corresponding positive- or negative-sequence currents are assumed to flow producing voltage drops in each conductor. The voltage drop per phase, divided by the current per phase results in the positive- or negative-sequence inductive reactance per phase for the three-phase circuit. To simplify the problem further, consider only one current flowing at a time. With all three currents flowing simultaneously, the resultant effect is the sum of the effects produced by each current flowing alone.

Taking phase a , the voltage drop is:

$$E_a - E_a' = I_a x_{aa} + I_b x_{ab} + I_c x_{ac} \quad (13)$$

where

- x_{aa} = self inductive reactance of conductor a .
- x_{ab} = mutual inductive reactance between conductor a , and conductor b .
- x_{ac} = mutual inductive reactance between conductor a and conductor c .

In terms of x_a and x_d , inductive reactance spacing factor,

$$x_{aa} = x_a + x_{d(ak)} \quad (14)$$

where only I_a is flowing and returning by a remote path e feet away, assumed to be the point k .

Considering only I_b flowing in conductor b and returning by the same remote path f feet away,

$$x_{ab} = x_{d(bk)} - x_{d(ba)} \quad (15)$$

where x_{ab} is the inductive reactance associated with the flux produced by I_b that links conductor a out to the return path f feet away.

Finally, considering only I_c flowing in conductor c and returning by the same remote path g feet away.

$$x_{ac} = x_{d(ck)} - x_{d(ca)} \quad (16)$$

where x_{ac} is the inductive reactance associated with the flux produced by I_c that links conductor a out to the return path g feet away.

With all three currents I_a , I_b , I_c flowing simultaneously, we have in terms of x_a and x_d factors:

$$E_a - E_a' = I_a(x_a + x_{d(ak)}) + I_b(x_{d(bk)} - x_{d(ba)}) + I_c(x_{d(ck)} - x_{d(ca)}) \quad (17)$$

Expanding and regrouping the terms we have:

$$E_a - E_a' = I_a x_a - I_b x_{d(ba)} - I_c x_{d(ca)} + [I_a x_{d(ak)} + I_b x_{d(bk)} + I_c x_{d(ck)}] \quad (18)$$

Since $I_c = -I_a - I_b$, the terms in the bracket may be written

$$I_a(x_{d(ak)} - x_{d(ck)}) + I_b(x_{d(bk)} - x_{d(ck)})$$

Using the definition of x_d , $0.2794 \frac{f}{60} \log \frac{D_{12}}{1}$, this expression

can be written

$$I_a \left(0.2794 \frac{f}{60} \log \frac{d_{(ak)}}{d_{(ck)}} \right) + I_b \left(0.2794 \frac{f}{60} \log \frac{d_{(bk)}}{d_{(ck)}} \right)$$

Assuming the distances $d_{(ak)}$, $d_{(ck)}$, and $d_{(bk)}$ to the remote path approach infinity, then the ratios $\frac{d_{(ak)}}{d_{(ck)}}$ and $\frac{d_{(bk)}}{d_{(ck)}}$ approach unity. Since the log of unity is zero, the two terms in the bracket are zero, and Eq. (18) reduces to

$$E_a - E_a' = I_a x_a - I_b x_{d(ba)} - I_c x_{d(ca)} \quad (19)$$

since

$$x_{d(ba)} = x_{d(ca)} = x_{d(bc)} = x_d, \text{ and } I_a = -I_b - I_c, \quad (20)$$

$$E_a - E_a' = I_a(x_a + x_d)$$

Dividing the equation by I_a ,

$$x_1 = x_2 = \frac{E_a - E_a'}{I_a} = x_a + x_d \text{ ohms per phase per mile} \quad (21)$$

where

x_a = inductive reactance for conductor a due to the flux out to one foot.

x_d = inductive reactance corresponding to the flux external to a one-foot radius from conductor a out to the center of conductor b or conductor c since the spacing between conductors is symmetrical.

Therefore, the positive- or negative-sequence inductive reactance per phase for a three-phase circuit with equilateral spacing is the same as for one conductor of a single-phase circuit as previously derived. Values of x_a for various conductors are given in the tables of electrical characteristics of conductors later in the chapter, and the values of x_d are given in the tables of inductive reactance spacing factors for various conductor spacings.

When the conductors are unsymmetrically spaced, the voltage drop for each conductor is different, assuming the currents to be equal and balanced. Also, due to the unsymmetrical conductor spacing, the magnetic field external to the conductors is not zero, thereby causing induced voltages in adjacent electrical circuits, particularly telephone circuits, that may result in telephone interference.

To reduce this effect to a minimum, the conductors are transposed so that each conductor occupies successively the

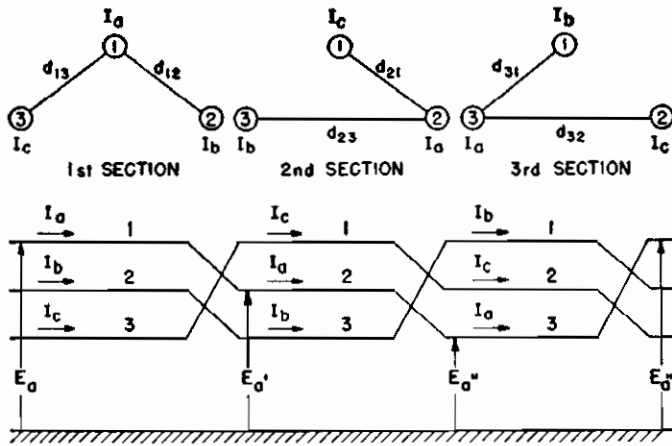

Fig. 13—A Three-conductor three-phase circuit (unsymmetrical spacing).

same positions as the other two conductors in two successive line sections. For three such transposed line sections, called a "barrel of transposition", the total voltage drop for each conductor is the same, and any electrical circuit parallel to the three transposed sections has a net voltage of very low magnitude induced in it due to normal line currents.

In the following derivation use is made of the general equations developed for the case of symmetrically spaced conductors. First, the inductive reactance voltage drop of phase *a* in each of the three line sections is obtained. Adding these together and dividing by three gives the average inductive reactance voltage drop for a line section. Referring to Fig. 13 and using Eq. (19) for the first line section where I_a is flowing in conductor 1,

$$E_a - E_a' = I_a x_a - I_b x_{d(12)} - I_c x_{d(13)}.$$

In the second line section where I_a is flowing in conductor 2,

$$E_a' - E_a'' = I_a x_a - I_b x_{d(23)} - I_c x_{d(21)}.$$

In the third line section where I_a is flowing in conductor 3,

$$E_a'' - E_a''' = I_a x_a - I_b x_{d(31)} - I_c x_{d(32)}.$$

Taking the average voltage drop per line section, we have

$$\begin{aligned} E_{avg} &= \frac{(E_a - E_a') + (E_a' - E_a'') + (E_a'' - E_a''')}{3} \\ &= \frac{3I_a x_a - I_b (x_{d(12)} + x_{d(23)} + x_{d(31)}) - I_c (x_{d(13)} + x_{d(21)} + x_{d(32)})}{3} \\ E_{avg} &= I_a x_a - (I_b + I_c) \frac{(x_{d(12)} + x_{d(23)} + x_{d(31)})}{3} \end{aligned}$$

Since

$$\begin{aligned} I_a + I_b + I_c &= 0, & I_a &= -(I_b + I_c) \\ E_{avg} &= I_a \left(x_a + \frac{x_{d(12)} + x_{d(23)} + x_{d(31)}}{3} \right). \end{aligned}$$

Dividing by I_a , we have the positive- or negative-sequence inductive reactance per phase

$$x_1 = x_2 = (x_a + x_d) \text{ ohms per phase per mile}$$

where

$$x_d = \frac{1}{3} (x_{d(12)} + x_{d(23)} + x_{d(31)}) \text{ ohms per phase per mile.} \tag{22}$$

Expressed in general terms,

$$x_d = \frac{1}{3} \left(0.2794 \frac{f}{60} \right) (\log d_{(12)} + \log d_{(23)} + \log d_{(31)})$$

$$x_d = \frac{1}{3} 0.2794 \frac{f}{60} \log d_{12} d_{23} d_{31}$$

$$x_d = 0.2794 \frac{f}{60} \log \sqrt[3]{d_{12} d_{23} d_{31}}$$

$$x_d = 0.2794 \frac{f}{60} \log \text{GMD}$$

where GMD (geometrical mean distance) = $\sqrt[3]{d_{12} d_{23} d_{31}}$, and is mathematically defined as the *n*th root of an *n*-fold product.

For a three-phase circuit where the conductors are not symmetrically spaced, we therefore have an expression for the positive- or negative-sequence inductive reactance, which is similar to the symmetrically spaced case except x_d is the inductive-reactance spacing factor for the GMD (geometric mean distance) of the three conductor separations. For x_d , then, in the case of unsymmetrical conductor spacing, we can take the average of the three inductive-reactance spacing factors

$$x_d = \frac{1}{3} (x_{d(12)} + x_{d(23)} + x_{d(31)}) \text{ ohms per phase per mile}$$

or we can calculate the GMD of the three spacings

$$\text{GMD} = \sqrt[3]{d_{12} d_{23} d_{31}} \text{ feet} \tag{23}$$

and use the inductive-reactance spacing factor for this distance. This latter procedure is perhaps the easier of the two methods.

x_a is taken from the tables of electrical characteristics of conductors presented later in the chapter, and x_d is taken

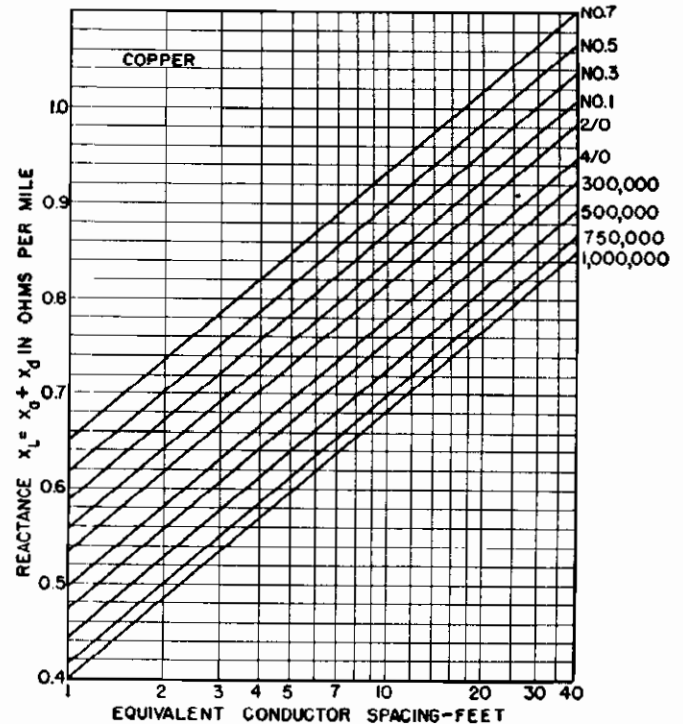

Fig. 14—Quick reference curves for 60-cycle inductive reactance of three-phase lines (per phase) using hard drawn copper conductors. For total reactance of single-phase lines multiply these values by two. See Eqs. (10) and (21).

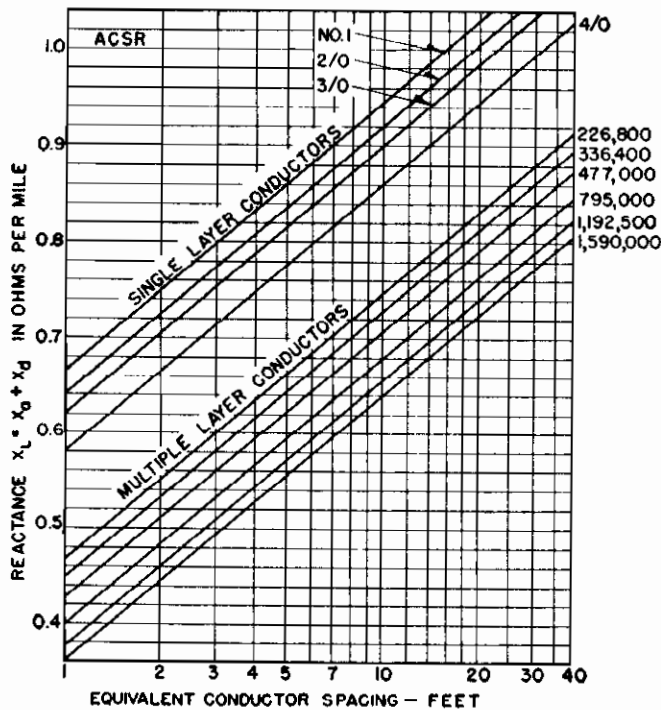

Fig. 15—Quick reference curves for 60-cycle inductive reactance of three-phase lines (per phase) using ACSR conductors. For total reactance of single-phase lines, multiply these values by two. See Eqs. (10) and (21).

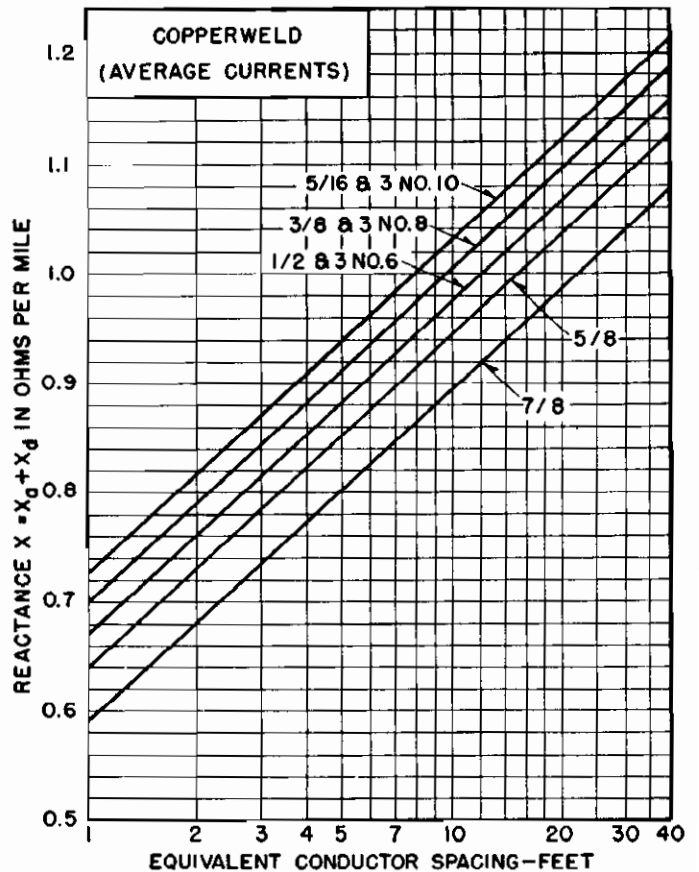

Fig. 17—Quick reference curves for 60-cycle inductive reactance of three-phase lines (per phase) using Copperweld conductors. For total reactance of single-phase lines multiply these values by two. See Eqs. (10) and (21).

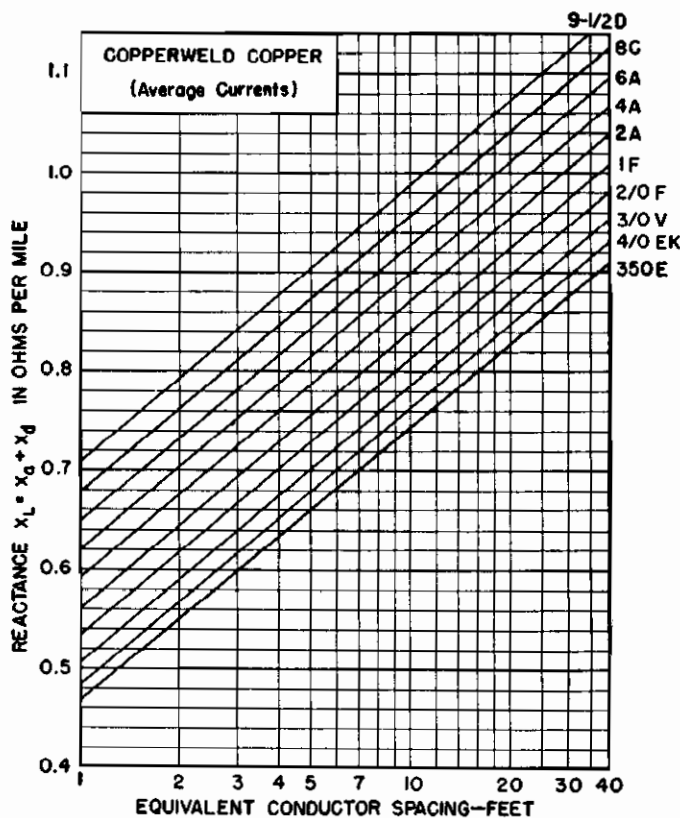

Fig. 16—Quick reference curves for 60-cycle inductive reactance of three-phase lines (per phase) using Copperweld-Copper conductors. For total reactance of single-phase lines multiply these values by two. See Eqs. (10) and (21).

from the tables of inductive-reactance spacing factors. Geometric mean distance (GMD) is sometimes referred to as "equivalent conductor spacing." For quick reference the curves of Figs. (14), (15), (16), and (17) have been plotted giving the reactance ($x_a + x_d$) for different conductor sizes and "equivalent conductor spacings."

Since most three-phase lines or circuits do not have conductors symmetrically spaced, the above formula for positive- or negative-sequence inductive reactance is generally used. This formula, however, assumes that the circuit is transposed.

When a single-circuit line or double-circuit line is not transposed, either the dissymmetry is to be ignored in the calculations, in which case the general symmetrical components methods can be used, or dissymmetry is to be considered, thus preventing the use of general symmetrical-components methods. In considering this dissymmetry, unequal currents and voltages are calculated for the three phases even when terminal conditions are balanced. In most cases of dissymmetry it is most practical to treat the circuit as transposed and use the equations for x_1 and x_2 derived for an unsymmetrically-spaced transposed circuit. Some error results from this method but in general it is small as compared with the laborious calculations that must be made when the method of symmetrical components cannot be used.

Positive- and Negative-Sequence Reactance of Parallel Circuits—When two parallel three-phase circuits are close together, particularly on the same tower, the effect of mutual inductance between the two circuits is not entirely eliminated by transpositions. By referring to Fig. 18 showing two transposed circuits on a single tower, the positive- or negative-sequence reactance of the parallel circuit is:

$$x_1 = x_2 = 0.2794 \frac{f}{60} \left[\frac{1}{2} \log_{10} \frac{\sqrt[3]{d_{ab}d_{bc}d_{ca}}}{GMR_{\text{conductor}}} - \frac{1}{2} \log_{10} \frac{(d_{aa'})^4(d_{bb'})^2}{(d_{ab'})^2(d_{ca'})^2(d_{bc'})^2} \right] \text{ ohms per phase per mile.} \quad (24)$$

in which the distances are those between conductors in the first section of transposition.

The first term in the above equation is the positive- or negative-sequence reactance for the combined circuits. The second term represents the correction factor due to the

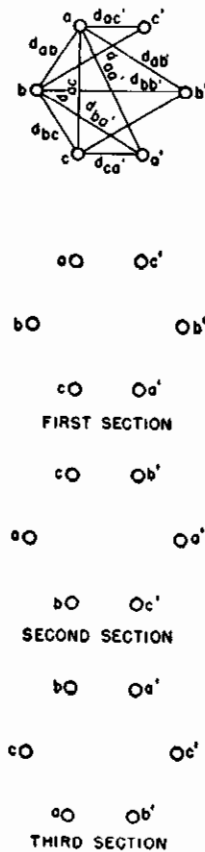

Fig. 18—Two parallel three-phase circuits on a single tower showing transpositions.

mutual reactance between the two circuits and may reduce the reactance three to five percent. The formula assumes transposition of the conductor as shown in Fig. 18.

The formula also assumes symmetry about the vertical axis but not necessarily about the horizontal axis.

As contrasted with the usual conductor arrangement as shown in Fig. 18, the arrangement of conductors shown in Fig. 19 might be used. However, this arrangement of con-

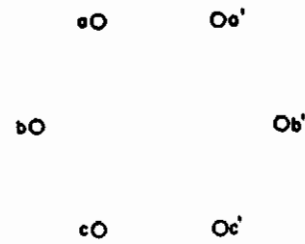

Fig. 19—Arrangement of conductors on a single tower which materially increases the inductance per phase.

ductors results in five to seven percent greater inductive reactance than the usual arrangement of conductors. This has been demonstrated in several references.³

3. Zero-Sequence Resistance and Inductive Reactance

The development of zero-sequence resistance and inductive reactance of aerial lines will be considered simultaneously as they are related quantities. Since zero-sequence currents for three-phase systems are in phase and equal in magnitude, they flow out through the phase conductors and return by a neutral path consisting of the earth alone, neutral conductor alone, overhead ground wires, or any combination of these. Since the return path often consists of the earth alone, or the earth in parallel with some other path such as overhead ground wires, it is necessary to use a method that takes into account the resistivity of the earth as well as the current distribution in the earth. Since both the zero-sequence resistance and inductive-reactance of three-phase circuits are affected by these two factors, their development is considered jointly.

As with the positive- and negative-sequence inductive reactance, first consider a single-phase circuit consisting of a single conductor grounded at its far end with the earth acting as a return conductor to complete the circuit. This permits the development of some useful concepts for calculating the zero-sequence resistance and inductive reactance of three-phase circuits.

Figure 20 shows a single-phase circuit consisting of a single outgoing conductor *a*, grounded at its far end with the return path for the current consisting of the earth. A second conductor, *b*, is shown to illustrate the mutual effects produced by current flowing in the single-phase circuit. The zero-sequence resistance and inductive reactance of this circuit are dependent upon the resistivity of the earth and the distribution of the current returning in the earth.

This problem has been analyzed by Rudenberg, Mayr,

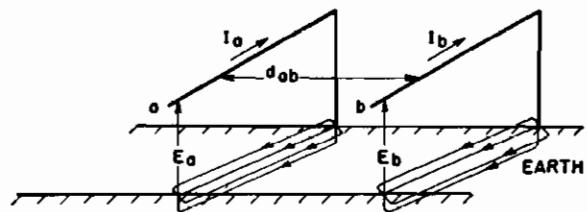

Fig. 20—A single conductor single phase circuit with earth return.

and Pollaczek in Europe, and Carson and Campbell in this country. The more commonly used method is that of Carson, who, like Pollaczek, considered the return current to return through the earth, which was assumed to have uniform resistivity and to be of infinite extent.

The solution of the problem is in two parts: (1) the determination of the self impedance z_s of conductor a with earth return (the voltage between a and earth for unit current in conductor a), and (2), the mutual impedance z_{gm} between conductors a and b with common earth return (the voltage between b and earth for unit current in a and earth return).

As a result of Carson's formulas, and using average heights of conductors above ground, the following fundamental simplified equations may be written:

$$z_s = r_c + 0.00159f + j0.004657f \log_{10} \frac{2160\sqrt{\frac{\rho}{f}}}{\text{GMR}} \quad \text{ohms per mile} \quad (25)$$

$$z_{gm} = 0.00159f + j0.004657f \log_{10} \frac{2160\sqrt{\frac{\rho}{f}}}{d_{ab}} \quad \text{ohms per mile} \quad (26)$$

where

r_c = resistance of conductor a per mile.

f = frequency in cps.

ρ = earth resistivity in ohms per meter cube.

GMR = geometric mean radius of conductor a in feet.

d_{ab} = distance between conductors a and b in feet.

A useful physical concept for analyzing earth-return circuits is that of concentrating the current returning through the earth in a fictitious conductor at some considerable depth below the outgoing conductor a . This equivalent depth of the fictitious return conductor is represented as D_e .

For the single-conductor, single-phase circuit with earth return now considered as a single-phase, two-wire circuit, the self-inductive reactance is given by the previously derived $j0.2794 \frac{f}{60} \log_{10} \frac{D_{12}}{\text{GMR}}$ (See Eq. (8)) for a single-phase,

two-wire circuit, or $j0.004657f \log_{10} \frac{D_e}{\text{GMR}}$ where D_e is

substituted for D_{12} , the distance between conductor a and the fictitious return conductor in the earth. This expression is similar to the inductive-reactance as given in Carson's simplified equation for self impedance. Equating the logarithmic expressions of the two equations,

$$j0.004657f \log_{10} \frac{D_e}{\text{GMR}} = j0.004657f \log_{10} \frac{2160\sqrt{\frac{\rho}{f}}}{\text{GMR}} \quad \text{or } D_e = 2160 \sqrt{\frac{\rho}{f}} \text{ feet.} \quad (27)$$

This defines D_e , equivalent depth of return, and shows that it is a function of earth resistivity, ρ , and frequency, f .

Also an inspection of Carson's simplified equations show that the self and mutual impedances contain a resistance component $0.00159f$, which is a function of frequency.

Rewriting Carson's equations in terms of equivalent depth of return, D_e ,

$$z_s = r_c + 0.00159f + j0.004657f \log_{10} \frac{D_e}{\text{GMR}} \quad \text{ohms per mile.} \quad (28)$$

$$z_{gm} = 0.00159f + j0.004657f \log_{10} \frac{D_e}{d_{ab}} \quad \text{ohms per mile.} \quad (29)$$

These equations can be applied to multiple-conductor circuits if r_c , the GMR and d_{ab} refer to the conductors as a group. Subsequently the GMR of a group of conductors are derived for use in the above equations.

To convert the above equations to zero-sequence quantities the following considerations must be made. Considering three conductors for a three-phase system, unit zero-sequence current consists of one ampere in each phase conductor and three amperes in the earth return circuit. To use Eqs. (28) and (29), replace the three conductors by a single equivalent conductor in which three amperes flow for every ampere of zero-sequence current. Therefore the corresponding zero-sequence self and mutual impedances per phase are three times the values given in Carson's simplified equations. Calling the zero sequence impedances z_0 and z_{0m} , we have:

$$z_0 = 3r_c + 0.00477f + j0.01397f \log_{10} \frac{D_e}{\text{GMR}} \quad \text{ohms per phase per mile.} \quad (30)$$

$$z_{0(m)} = 0.00477f + j0.01397f \log_{10} \frac{D_e}{d_{ab}} \quad \text{ohms per phase per mile} \quad (31)$$

where f = frequency in cps.

r_c = resistance of a conductor equivalent to the three conductors in parallel. $3r_c$ therefore equals the resistance of one conductor for a three-phase circuit.

GMR = geometric mean radius for the group of phase conductors. This is different than the GMR for a single conductor and is derived subsequently as $\text{GMR}_{\text{circuit}}$.

d_{ab} = distance from the equivalent conductor to a parallel conductor, or some other equivalent conductor if the mutual impedance between two parallel three-phase circuits is being considered.

For the case of a single overhead ground wire, Eq. (30) gives the zero-sequence self impedance. Equation (31) gives the zero-sequence mutual impedance between two overhead ground wires.

Zero-sequence self impedance of two ground wires with earth return

Using Eq. (30) the zero-sequence self impedance of two ground wires with earth return can be derived.

$$z_0 = 3r_c + 0.00477f + j0.01397f \log_{10} \frac{D_e}{\text{GMR}} \quad \text{ohms per phase per mile} \quad (30)$$

where r_c = resistance of a single conductor equivalent to the two ground wires in parallel. (r_c therefore

becomes $\frac{r_a}{2}$ where r_a is the resistance of one of the two ground wires).

GMR=geometric mean radius for the two ground wires. (GMR therefore becomes $\sqrt[3]{(\text{GMR})^2_{\text{conductor}} d_{xy}}$ or $\sqrt[3]{(\text{GMR})(d_{xy})}$

where d_{xy} is the distance between the two conductors x and y .)

Substituting $\frac{r_a}{2}$ for r_o and $\sqrt[3]{(\text{GMR})(d_{xy})}$ for GMR in Eq. (30), the zero-sequence self impedance of two ground wires with earth return becomes

$$z_o = \frac{3r_a}{2} + 0.00477f + j0.01397f \log_{10} \frac{D_o}{\sqrt[3]{(\text{GMR})(d_{xy})}} \quad (32)$$

ohms per mile per phase.

Zero-sequence self impedance of n ground wires with earth return

Again using Eq. (30), the zero-sequence self impedance of n ground wires with earth return can be developed.

$$z_o = 3r_o + 0.00477f + j0.01397f \log_{10} \frac{D_o}{\text{GMR}} \quad (30)$$

ohms per mile per phase.

Since r_o is the resistance of a single conductor equivalent to n ground wires in parallel, then $r_o = \frac{r_a}{n}$ where r_a is the resistance of one of the n ground wires, in ohms per phase per mile.

GMR is the geometric mean radius of the n ground wires as a group, which may be written as follows in terms of all possible distances,

$$\text{GMR} = \sqrt[3]{(\text{GMR})^n_{\text{conductor}} \frac{(d_{(g_1g_2)}d_{(g_1g_3)} \dots d_{(g_1g_n)})(d_{(g_2g_1)}d_{(g_2g_3)} \dots d_{(g_2g_n)})(d_{(g_3g_1)}d_{(g_3g_2)} \dots d_{(g_3g_n)})(d_{(g_n g_1)}d_{(g_n g_2)} \dots d_{(g_n g_{n-1})})}{\text{feet.}}}$$

This expression can also be written in terms of all possible pairs of distances as follows.

$$\text{GMR} = \sqrt[3]{(\text{GMR})^n_{\text{conductor}} \frac{(d_{(g_1g_2)}d_{(g_1g_3)} \dots d_{(g_1g_n)})^2 (d_{(g_2g_3)} \dots d_{(g_2g_n)})^2 (d_{(g_3g_n)})^2}{\text{feet.}}} \quad (33)$$

The equation for zero-sequence self impedance of n ground wires with earth return can therefore be obtained by substituting $\frac{r_a}{n}$ for r_o and Eq. (33) for GMR in Eq. (30).

Self impedance of parallel conductors with earth return

In the preceding discussion the self and mutual impedances between single cylindrical conductors with earth return were derived from which the zero-sequence self and mutual reactances were obtained. These expressions were expanded to include the case of multiple overhead ground wires, which are not transposed. The more common case is that of three-phase conductors in a three-phase circuit which can be considered to be in parallel when zero-sequence currents are considered. Also the three conductors in a three-phase circuit are generally transposed. This factor was not considered in the preceding cases for multiple overhead ground wires.

In order to derive the zero-sequence self impedance of three-phase circuits it is first necessary to derive the self impedance of three-phase circuits taking into account

transpositions. The expression for self impedance is then converted to zero-sequence self impedance in a manner analogous to the case of single conductors with earth return.

Consider three phase conductors $a, b,$ and c as shown in Fig. 21. With the conductors transposed the current

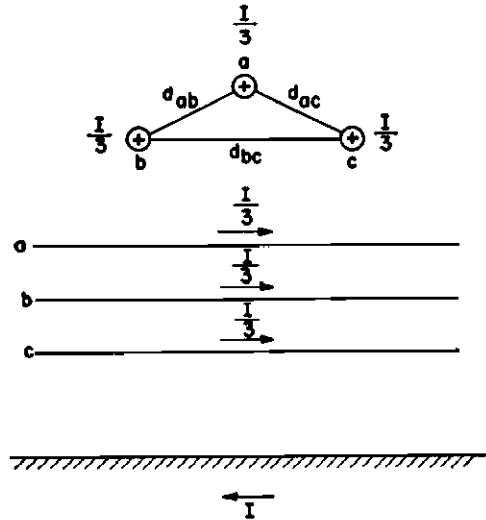

Fig. 21—Self impedance of parallel conductors with earth return.

divides equally between the conductors so that for a total current of unity, the current in each conductor is one third.

The voltage drop in conductor a for the position indicated in Fig. 21 is

$$\frac{z_{aa}}{3} + \frac{z_{ab}}{3} + \frac{z_{ac}}{3}$$

For conductor b :

$$\frac{z_{ab}}{3} + \frac{z_{bb}}{3} + \frac{z_{bc}}{3}$$

and for conductor c :

$$\frac{z_{ac}}{3} + \frac{z_{bc}}{3} + \frac{z_{cc}}{3}$$

in which $z_{aa}, z_{bb},$ and z_{cc} are the self impedances of the three conductors with ground return and $z_{ab}, z_{bc},$ and z_{ac} are the mutual impedances between the conductors.

Since conductor a takes each of the three conductor positions successively for a transposed line, the average drop per conductor is

$$\frac{1}{9}(z_{aa} + z_{bb} + z_{cc} + 2z_{ab} + 2z_{bc} + 2z_{ac}).$$

Substituting the values of self and mutual impedances given by Eqs. (28) and (29) in this expression,

$$z_s = \frac{1}{9} \left[3r_o + 9(0.00159f) + j0.004657f \left(3 \log_{10} \frac{D_o}{\text{GMR}} + 2 \log_{10} \frac{D_o}{d_{ab}} + 2 \log_{10} \frac{D_o}{d_{bc}} + 2 \log_{10} \frac{D_o}{d_{ac}} \right) \right]$$

ohms per mile.

$$z_s = \frac{r_o}{3} + 0.00159f + j0.004657f \log_{10} \frac{D_o}{\sqrt[3]{(\text{GMR})^3 d_{ab}^2 d_{bc}^2 d_{ca}^2}} \quad (34)$$

ohms per mile.

The ninth root in the denominator of the logarithmic term is the GMR of the circuit and is equal to an infinitely thin tube which would have the same inductance as the three-conductor system with earth return shown in Fig. 21.

$$\text{GMR}_{\text{circuit}} = \sqrt[9]{(\text{GMR})^3_{\text{conductor}} d_{ab}^2 d_{bc}^2 d_{ca}^2} \text{ feet.}$$

$$\text{GMR}_{\text{circuit}} = \sqrt[9]{(\text{GMR})^3_{\text{conductor}} (d_{ab} d_{bc} d_{ca})^2} \text{ feet.}$$

$$\text{GMR}_{\text{circuit}} = \sqrt[9]{\text{GMR}_{\text{conductor}} (\sqrt[3]{d_{ab} d_{bc} d_{ca}})^2} \text{ feet.}$$

By previous derivation (See Eq. (23)), $\text{GMD}_{\text{separation}}$
 $= \sqrt[3]{d_{ab} d_{bc} d_{ca}}$ feet.

$$\text{Therefore } \text{GMR}_{\text{circuit}} = \sqrt[9]{(\text{GMR})_{\text{conductor}} (\text{GMD})^2_{\text{separation}}} \text{ feet.} \quad (35)$$

Substituting $\text{GMR}_{\text{circuit}}$ from equation (35) in equation (34),

$$z_g = \frac{r_c}{3} + 0.00159f + j0.004657f \log_{10} \frac{D_o}{\sqrt[9]{(\text{GMR})_{\text{conductor}} (\text{GMD})^2_{\text{separation}}}} \text{ ohms per mile.} \quad (36)$$

In equations (34) and (36), r_c is the resistance per mile of one phase conductor.

Zero-sequence self impedance of three parallel conductors with earth return

Equation (36) gives the self impedance of three parallel conductors with earth return and was derived for a total current of unity divided equally among the three conductors. Since zero-sequence current consists of unit current in each conductor or a total of three times unit current for the group of three conductors, the voltage drop for zero-sequence currents is three times as great. Therefore Eq. (36) must be multiplied by three to obtain the zero-sequence self impedance of three parallel conductors with earth return. Therefore,

$$z_0 = r_c + 0.00477f + j0.01397f \log_{10} \frac{D_o}{\sqrt[9]{\text{GMR}_{\text{conductor}} (\text{GMD})^2_{\text{separation}}}} \text{ ohms per phase per mile} \quad (37)$$

where $\sqrt[9]{\text{GMR}_{\text{conductor}} (\text{GMD})^2_{\text{separation}}}$ is the $\text{GMR}_{\text{circuit}}$ derived in equation (35) or $\sqrt[9]{(\text{GMR})^3_{\text{conductor}} d_{ab}^2 d_{bc}^2 d_{ca}^2}$

Zero-sequence mutual impedance between two circuits with earth return

Using a similar method of derivation the zero-sequence mutual impedance between 2 three-phase circuits with common earth return is found to be

$$z_{0(m)} = 0.00477f + j0.01397f \log_{10} \frac{D_o}{\text{GMD}} \text{ ohms per phase per mile} \quad (38)$$

where GMD is the geometric mean distance between the 2 three-phase circuits or the ninth root of the product of the nine possible distances between conductors in one group and conductors in the other group. Note the similarity between Eq. (38) and Eq. (31)

Zero-sequence self impedance of two identical parallel circuits with earth return

For the special case where the two parallel three-phase circuits are identical, following the same method of derivation

$$z_0 = \frac{r_c}{2} + 0.00477f + j0.01397f \log_{10} \frac{D_o}{\sqrt{(\text{GMR})(\text{GMD})}} \text{ ohms per phase per mile} \quad (39)$$

in which GMR is the geometric mean radius of one set of conductors, $(\sqrt[9]{(\text{GMR})_{\text{conductor}} (\text{GMD})^2_{\text{separation}}})$, and GMD is the geometric mean distance between the two sets of conductors or the ninth root of the product of the nine possible distances between conductors in one circuit and conductors in the other circuit.

This equation is the same as $\frac{1}{2}(z_0 + z_{0(m)})$ where z_0 is the zero-sequence self impedance of one circuit by equation (37) and $z_{0(m)}$ is the zero-sequence mutual impedance between two circuits as given by Eq. (38). For non-identical circuits it is better to compute the mutual and self impedance for the individual circuits, and using $\frac{1}{2}(z_0 + z_{0(m)})$ compute the zero-sequence self impedance.

Zero-sequence mutual impedance between one circuit (with earth return) and n ground wires (with earth return)

Figure 22 shows a three-phase circuit with n ground

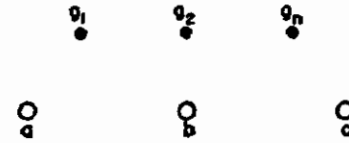

Fig. 22—A three-conductor three-phase circuit (with earth return) and n ground wires (with earth return)

wires. Equation (31) gives the zero sequence mutual impedance between two conductors:

$$z_{0(m)} = 0.00477f + j0.01397f \log_{10} \frac{D_o}{d_{ab}} \text{ ohms per phase per mile} \quad (31)$$

where d_{ab} is the distance between the two conductors. This equation can be applied to two groups of conductors if d_{ab} is replaced by the GMD or geometric mean distance between the two groups. In Fig. 22, if the ground wires are considered as one group of conductors, and the phase conductors a, b, c, are considered as the second group of conductors, then the GMD between the two groups is

$$\text{GMD} = \sqrt[9]{d_{ag1} d_{bg1} d_{cg1} \cdots d_{agn} d_{bn} d_{cn}} \text{ feet}$$

Substituting this quantity for d_{ab} in Eq. (31) results in an equation for the zero-sequence mutual impedance between one circuit and n ground wires. This $z_{0(m)}$ is $z_{0(ng)}$.

$$z_{0(m)} = 0.00477f + j0.01397f \log_{10} \frac{D_o}{\sqrt[3]{d_{ag1}d_{bg1}d_{cg1} - d_{agn}d_{bgn}d_{cgn}}} \text{ ohms per phase per mile.} \quad (40)$$

Zero-sequence impedance of one circuit with n ground wires (and earth) return.

Referring to Fig. 20 the zero-sequence self impedance of a single conductor, and the zero-sequence mutual impedance between a single conductor and another single conductor with the same earth return path was derived. These values are given in Eqs. (30) and (31). As stated before, these equations can be applied to multi-conductor circuits by substituting the circuit GMR for the conductor GMR in Eq. (30) and the GMD between the two circuits for d_{ab} in Eq. (31).

First, consider the single-conductor, single-phase circuit with earth return and one ground wire with earth return. Referring to Fig. 20 conductor a is considered as the single conductor of the single-phase circuit and conductor b will be used as the ground wire.

Writing the equations for E_a and E_b , we have:

$$E_a = I_a z_{aa} + I_b z_m \quad (41)$$

$$E_b = I_a z_m + I_b z_{bb}. \quad (42)$$

If we assume conductor b as a ground wire, then $E_b = 0$ since both ends of this conductor are connected to ground. Therefore solving Eq. (42) for I_b and substituting this value of I_b in Eq. (41),

$$E_a = I_a \left(z_{aa} - \frac{z_m^2}{z_{bb}} \right).$$

To obtain z_a , divide E_a by I_a , and the result is

$$z_a = z_{aa} - \frac{z_m^2}{z_{bb}} \quad (43)$$

The zero-sequence impedance of a single-conductor, single-phase circuit with one ground wire (and earth) return is therefore defined by Eq. (43) when zero-sequence self impedances of single-conductor, single-phase circuits are substituted for z_{aa} and z_{bb} and the zero-sequence mutual impedance between the two conductors is substituted for z_m . Equation (43) can be expanded to give the zero-sequence impedance of a three-phase circuit with n ground wires (and earth) return.

$$z_0 = z_{0(a)} - \frac{z_{0^2(a,g)}}{z_{0(g)}} \quad (44)$$

Where z_0 = zero-sequence impedance of one circuit with n ground wires (and earth) return.

$z_{0(a)}$ = zero-sequence self impedance of the three-phase circuit.

$z_{0(g)}$ = zero-sequence self impedance of n ground wires.

$z_{0(a,g)}$ = zero-sequence mutual impedance between the phase conductors as one group of conductors and the ground wire(s) as the other conductor group.

Equation (44) results in the equivalent circuit of Fig. 23 for determining the zero-sequence impedance of one circuit with n ground wires (and earth) return.

General Method for Zero-Sequence Calculations

The preceding sections have derived the zero-sequence self and mutual impedances for the more common circuit arrangements both with and without ground wires. For more complex circuit and ground wire arrangements a

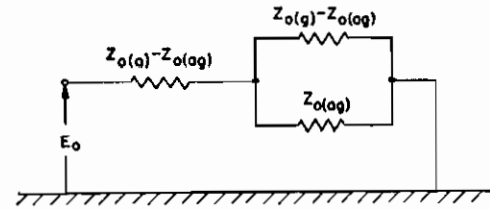

Fig. 23—Equivalent circuit for zero-sequence impedance of one circuit (with earth return) and n ground wires (with earth return).

general method must be used to obtain the zero-sequence impedance of a particular circuit in such arrangements.

The general method consists of writing the voltage drop for each conductor or each group of conductors in terms of zero-sequence self and mutual impedances with all conductors or groups of conductors present. Ground wire conductors or groups of conductors have their voltage drops equal to zero. Solving these simultaneous equations for $\frac{E_0}{I_0}$ of the desired circuit gives the zero-sequence impedance of that circuit in the presence of all the other zero-sequence circuits.

This general method is shown in detail in Chap. 2, Part X, Zero-Sequence Reactances. Two circuits, one with two overhead ground wires and one with a single overhead ground wire are used to show the details of this more general method.

Practical Calculation of Zero-Sequence Impedance of Aerial Lines—In the preceding discussion a number of equations have been derived for zero-sequence self and mutual impedances of transmission lines taking into account overhead ground wires. These equations can be further simplified to make use of the already familiar quantities r_a , x_a , and x_d . To do this two additional quantities, r_e and x_e are necessary that result from the use of the earth as a return path for zero-sequence currents. They are derived from Carson's formulas and can be defined as follows:

$$r_e = 0.00477f \text{ ohms per phase per mile.}$$

$$x_e = 0.006985f \log_{10} 4.6655 \times 10^6 \frac{\rho}{f} \text{ ohms per phase per mile.} \quad (46)$$

It is now possible to write the previously derived equations for zero-sequence self and mutual impedances in terms of r_a , x_a , x_d , r_e , and x_e . The quantities r_a , x_a , x_d are given in the tables of Electrical Characteristics of Conductors and Inductive Reactance Spacing Factors. The quantities r_e and x_e are given in Table 7 as functions of earth resistivity, ρ , in meter ohms for 25, 50, and 60 cycles per second. The following derived equations are those most commonly used in the analysis of power system problems.

Zero-sequence impedance—one circuit (with earth return) but without ground wires

$$z_0 = r_e + 0.00477f + j0.01397f \log_{10} \frac{D_e}{\sqrt[3]{(\text{GMR})_{\text{conductor}}(\text{GMD})^2_{\text{separation}}}} \text{ ohms per phase per mile.} \quad (37)$$

$$z_0 = r_a + r_e + j0.006985f \log_{10} 4.6656 \times 10^6 \frac{\rho}{f} + j0.2794 \frac{f}{60} \log_{10} \frac{1}{\text{GMR}_{\text{conductor}}} - j2(0.2794) \frac{f}{60} \log_{10} \text{GMD}_{\text{separation}}$$

$$z_0 = r_a + r_e + j(x_e + x_a - 2x_d) \text{ ohms per phase per mile} \quad (47)$$

where $x_d = \frac{1}{3}(x_{d(ab)} + x_{d(bc)} + x_{d(ca)})$
and $x_{d(ab)} = x_d$ from Table 6 for spacing a to b , etc.

Mutual zero-sequence impedance between two circuits (with earth return) but without ground wires

$$z_{0(m)} = 0.00477f + j0.01397f \log_{10} \frac{D_e}{\text{GMD}} \text{ ohms per phase per mile.} \quad (38)$$

$$z_{0(m)} = r_e + j0.006985f \log_{10} 4.665 \times 10^6 \frac{\rho}{f} - j0.006985f \log_{10} \text{GMD}^2$$

$$z_{0(m)} = r_e + j(x_e - 3x_d) \text{ ohms per phase per mile} \quad (48)$$

where x_d is $\frac{1}{9}(x_{d(aa')} + x_{d(ab')} + x_{d(ac')} + x_{d(ba')} + x_{d(bb')} + x_{d(bc')} + x_{d(ca')} + x_{d(cb')} + x_{d(cc')})$

Zero-sequence self impedance—one ground wire (with earth return)

$$z_{0(g)} = 3r_e + 0.00477f + j0.01397f \log_{10} \frac{D_e}{\text{GMR}_{\text{conductor}}} \text{ ohms per phase per mile.} \quad (30)$$

$$z_{0(g)} = 3r_a + r_e + j0.006985f \log_{10} 4.6656 \times 10^6 \frac{\rho}{f} + 0.006985f \log_{10} \frac{1}{(\text{GMR})^2_{\text{conductor}}}$$

$$z_{0(g)} = 3r_a + r_e + j(x_e + 3x_a) \text{ ohms per phase per mile.} \quad (49)$$

Zero sequence self impedance—two ground wires (with earth return)

$$z_{0(g)} = \frac{3r_a}{2} + 0.00477f + j0.01397f \log_{10} \frac{D_e}{\sqrt[2]{(\text{GMR})_{\text{conductor}}d_{xy}}} \text{ ohms per phase per mile.} \quad (32)$$

$$z_{0(g)} = \frac{3r_a}{2} + r_e + j0.006985f \log_{10} 4.6656 \times 10^6 \frac{\rho}{f} + \frac{0.8382}{2} \log \frac{1}{\text{GMR}} - \frac{0.8382}{2} \log \frac{d_{xy}}{1}$$

$$z_{0(g)} = \frac{3r_a}{2} + r_e + j(x_e + \frac{3}{2}x_a - \frac{3}{2}x_d) \text{ ohms per phase per mile} \quad (50)$$

where

$x_d = x_d$ from Table 6 for spacing between ground wires, d_{xy} .

Zero-sequence self impedance— n ground wires (with earth return)

$$z_{0(g)} = 3r_e + 0.00477f + j0.01397f \log_{10} \frac{D_e}{\text{GMR}} \text{ ohms per phase per mile} \quad (30)$$

where $r_e = \frac{r_a}{n}$ ohms per phase per mile.

$$\text{GMR} = \sqrt[3]{(\text{GMR})^n_{\text{conductor}}(d_{g1g2}d_{g1g3} \dots d_{g1gn})(d_{g2g1}d_{g2g3} \dots d_{g2gn})(d_{g3g1}d_{g3g2} \dots d_{g3gn})(d_{gng1}d_{gng2} \dots d_{gng(n-1)})}$$

$$z_{0(g)} = \frac{3r_a}{n} + r_e + jx_e + j\frac{3}{2}(0.2794) \frac{f}{60} \log_{10} 4.665 \times 10^6 \frac{\rho}{f} + j\frac{3}{2}(0.2794) \frac{f}{60} \log_{10} \frac{1}{(\text{GMR})^2_{\text{conductor}}} - j\frac{3}{2}(0.2794) \frac{f}{60} \log_{10} \left[(d_{g1g2}d_{g1g3} \dots d_{g1gn})(d_{g2g1}d_{g2g3} \dots d_{g2gn})(d_{g3g1}d_{g3g2} \dots d_{g3gn})(d_{gng1}d_{gng2} \dots d_{gng(n-1)}) \right]^{\frac{2}{n^2}}$$

$$z_{0(g)} = \frac{3}{n}r_a + r_e + j(x_e + \frac{3x_a}{n} - \frac{3(n-1)}{n}x_d) \text{ ohms per mile per phase} \quad (51)$$

where $x_d = \frac{1}{n(n-1)}$ (sum of $x_{d's}$ for all possible distances between all ground wires.)

or $x_d = \frac{2}{n(n-1)}$ (sum of $x_{d's}$ for all possible distances between all possible pairs of ground wires).

Zero-sequence mutual impedance between one circuit (with earth return) and n ground wires (with earth return)

$$z_{0(ag)} = 0.00477f + j0.01397f \log_{10} \frac{D_e}{\sqrt[3n]{d_{ag1}d_{bg1}d_{cg1} \dots d_{agn}d_{bgn}d_{cgn}}} \text{ ohms per phase per mile.} \quad (40)$$

$$z_{0(ag)} = r_e + j0.006985f \log_{10} 4.6656 \times 10^6 \frac{\rho}{f} - j0.006985f \log_{10} \left(\sqrt[3n]{d_{ag1}d_{bg1}d_{cg1} \dots d_{agn}d_{bgn}d_{cgn}} \right)^2$$

$$z_{0(ag)} = r_e + j(x_e - 3x_d) \text{ ohms per phase per mile} \quad (52)$$

where $x_d = \frac{1}{3n}(x_{d(ag1)} + x_{d(bg1)} + x_{d(cg1)} + \dots + x_{d(agn)} + x_{d(bgn)} + x_{d(cgn)})$.

Zero-sequence impedance—One circuit with n ground wires (and earth return)

$$z_0 = z_{0(a)} - \frac{z_{0(ag)}^2}{z_{0(g)}} \quad (44)$$

where $z_{0(a)}$ = zero-sequence self impedance of the three-phase circuit.

$z_{0(g)}$ = zero-sequence self impedance of n ground wires.

$z_{0(ag)}$ = zero-sequence mutual impedance between the three-phase circuit as one group of conductors and the ground wire(s) as the other conductor group.

4. Positive-, Negative-, and Zero-sequence Shunt Capacitive Reactance

The capacitance of transmission lines is generally a negligible factor at the lower voltages under normal operating conditions. However, it becomes an appreciable effect for higher voltage lines and must be taken into consideration when determining efficiency, power factor, regulation, and voltage distribution under normal operating conditions. Use of capacitance in determining the performance of long high voltage lines is covered in detail in Chap. 9, "Regulation and Losses of Transmission Lines."

Capacitance effects of transmission lines are also useful in studying such problems as inductive interference, lightning performance of lines, corona, and transients on power systems such as those that occur during faults.

For these reasons formulas are given for the positive-, negative-, and zero-sequence shunt capacitive reactance for the more common transmission line configurations. The case of a two-conductor, single-phase circuit is considered to show some of the fundamentals used to obtain these formulas. For a more detailed analysis of the capacitance problem a number of references are available.^{2,4,5}

In deriving capacitance formulas the distribution of a charge, q , on the conductor surface is assumed to be uniform. This is true because the spacing between conductors in the usual transmission circuit is large and therefore the charges on surrounding conductors produce negligible distortion in the charge distribution on a particular conductor. Also, in the case of a single isolated charged conductor, the voltage between any two points of distances x and y meters radially from the conductor can be defined as the work done in moving a unit charge of one coulomb from point P_2 to point P_1 through the electric field produced by the charge on the conductor. (See Fig. 24.) This is given

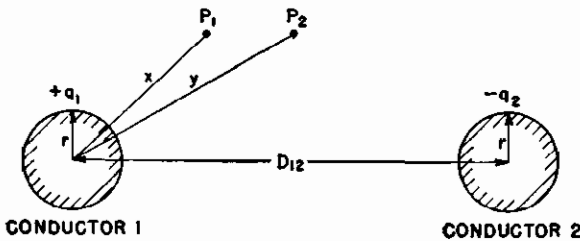

Fig. 24—A two conductor single phase circuit (capacitance).

by

$$V_{xy} = 18 \times 10^9 q \ln \frac{y}{x} \text{ volts} \quad (53)$$

where q is the conductor charge in coulombs per meter.

By use of this equation and the principle of superposition, the capacitances of systems of parallel conductors can be determined.

Applying Eq. (53) and the principle of superposition to the two-conductor, single-phase circuit of Fig. 24 assuming conductor 1 alone to have a charge q_1 , the voltage between conductors 1 and 2 is

$$V_{12} = 18 \times 10^9 q_1 \ln \frac{D_{12}}{r} \text{ volts.} \quad (54)$$

This equation shows the work done in moving a unit charge from conductor 2 a distance D_{12} meters to the surface of conductor 1 through the electric field produced by q_1 . Now assuming only conductor 2, having a charge q_2 , the voltage between conductors 1 and 2 is

$$V_{12} = 18 \times 10^9 q_2 \ln \frac{r}{D_{12}} \text{ volts.} \quad (55)$$

This equation shows the work done in moving a unit charge from the outer radius of conductor 2 to conductor 1 a distance D_{12} meters away through the electric field produced by q_2 .

With both charges q_1 and q_2 present, by the principle of superposition the voltage V_{12} is the sum of the voltages resulting from q_1 and q_2 existing one at a time. Therefore V_{12} is the sum of Eqs. (54) and (55) when both charges q_1 and q_2 are present.

$$V_{12} = 18 \times 10^9 \left(q_1 \ln \frac{D_{12}}{r} + q_2 \ln \frac{r}{D_{12}} \right) \text{ volts.} \quad (56)$$

Also if the charges on the two conductors are equal and their sum is zero,

$$q_1 + q_2 = 0 \text{ or } q_2 = -q_1$$

Substituting $-q_1$ for q_2 in equation (56)

$$V_{12} = 36 \times 10^9 q_1 \ln \frac{D_{12}}{r} \text{ volts.} \quad (57)$$

The capacitance between conductors 1 and 2 is the ratio of the charge to the voltage or

$$\frac{q_1}{V_{12}} = C_{12} = \frac{1}{36 \times 10^9 \ln \frac{D_{12}}{r}} \text{ farads per meter.} \quad (58)$$

The capacitance to neutral is twice that given in Eq. (58) because the voltage to neutral is half of V_{12} .

$$C_n = \frac{1}{18 \times 10^9 \ln \frac{D_{12}}{r}} \text{ farads per meter.} \quad (59)$$

The shunt-capacitive reactance to neutral (or per conductor) is $x_{cn} = \frac{1}{2\pi f C}$ or in more practical units

$$x_{cn} = 0.0683 \frac{60}{f} \log_{10} \frac{D_{12}}{r} \text{ megohms per conductor per mile.} \quad (60)$$

This can be written as

$$x_{cn} = 0.0683 \frac{60}{f} \log_{10} \frac{1}{r} + 0.0683 \frac{60}{f} \log_{10} \frac{D_{12}}{1} \text{ megohms per conductor per mile} \quad (61)$$

where D_{12} and r are in feet and f is cycles per second. Eq. (61) may be written

$$x_{cn} = x_a' + x_d' \text{ megohms per conductor per mile.} \quad (62)$$

The derivation of shunt-capacitive reactance formulas brings about terms quite analogous to those derived for inductive reactance, and as in the case of inductive reactance, these terms can be resolved into components as shown in Eq. (62). The term x_a' accounts for the electrostatic flux within a one foot radius and is the term

$0.0683 \frac{60}{f} \log_{10} \frac{1}{r}$ in Eq. (61). It is a function of the conductor outside radius only. The term x_d' accounts for the electric flux between a one foot radius and the distance D_{12} to the other conductor and is the term $0.0683 \frac{60}{f} \log_{10} \frac{D_{12}}{1}$ in Eq. (61). Note that unlike inductive-reactance

where the conductor geometric mean radius (GMR) is used, in capacitance calculations the only conductor radius used is the actual physical radius of the conductor in feet.

Zero-sequence capacitive reactance is, like inductive-reactance, divided into components x_a' taking into account the electrostatic flux within a one-foot radius, x_d' taking into account the electrostatic flux external to a radius of one foot out to a radius D feet, and x_e' taking into account the flux external to a radius of one foot and is a function of the spacing to the image conductor.

$$x_e' = \frac{12.30}{f} \log_{10} 2h \text{ megohms per mile per conductor} \quad (63)$$

where h = conductor height above ground.
 f = frequency in cps.

x_a' is given in the tables of Electrical Characteristics of conductors, x_d' is given in Table 8, Shunt-Capacitive Reactance Spacing Factor, and x_e' is given in Table 9, Zero-Sequence Shunt-Capacitive Reactance Factor.

The following equations have been derived in a manner similar to those for the two-conductor, single-phase case, making use of the terms x_a' , x_d' and x_e' . They are summarized in the following tabulation.

Shunt-Capacitive Reactance, x_c , of Three-Phase Circuits (Conductors a, b, c)

(a) Positive (and negative) sequence x_c .
 $x_1' = x_2' = x_3' = x_a' + x_d'$ megohms per conductor per mile. (64)

$$x_d' = \frac{1}{3} (\text{sum of all three } x_d' \text{'s for distances between all possible pairs}).$$

$$= \frac{1}{3} (x_{d'ab} + x_{d'ac} + x_{d'bc}). \text{ See Table (8)} \quad (65)$$

(b) Zero-Sequence x_c of one circuit (and earth).
 $x_{0(a)}' = x_a' + x_e' - 2x_d'$ megohms per conductor per mile. (66)

x_d' = value given in Eq. (65). Table (9) gives x_e' .

(c) Zero-Sequence x_c of one ground wire (and earth).
 $x_{0(g)}' = 3x_{a'(g)}' + x_{e'(g)}$ megohms per conductor per mile. (67)

(d) Zero-Sequence x_c of two ground wires (and earth).
 $x_{0(g)}' = \frac{3}{2} x_{a'(g)}' + x_{e'(g)} - \frac{3}{2} x_d'$ megohms per conductor per mile. (68)

$x_d' = x_{d'(g1g2)}' = x_d'$ for distance between ground wires.

(e) Zero Sequence x_c of n ground wires (and earth).
 $x_{0(g)}' = x_e' + \frac{3}{n} x_a' - \frac{3(n-1)}{n} x_d'$ megohms per conductor per mile (69)

where

$$x_d' = \frac{2}{n(n-1)} (\text{sum of all } x_d' \text{'s for all possible distances between all possible pairs of ground wires})$$

$$\text{or } x_d' = \frac{1}{n(n-1)} (\text{sum of all } x_d' \text{'s for all possible distances between all ground wires}).$$

(f) Zero-Sequence x_c between one circuit (and earth) and n ground wires (and earth)
 $x_{0'(ag)}' = x_e' - 3x_d'$ megohms per conductor per mile. (70)

$$x_d' = \frac{1}{3n} (x_{d'(ag1)}' + x_{d'(bg1)}' + x_{d'(cg1)}' \cdots + x_{d'(agn)}' + x_{d'(bgn)}' + x_{d'(cgn)}').$$

(g) Zero-Sequence x_c of one circuit with n ground wires
 $x_0' = x_{0'(a)}' - \frac{x_{0'(ag)}'^2}{x_{0'(g)}'}$ megohms per conductor per mile. (71)

Shunt Capacitive Reactance, x_c , of Single-Phase Circuits (Conductors a and b)

(h) x_c of single-phase circuit of two identical conductors
 $x' = 2(x_a' + x_d')$ megohms per mile of circuit. (72)
 $x_d' = x_d'$ for spacing between conductors.

(i) x_c of single-phase circuit of two non-identical conductors a and b .

$$x' = x_{a'(a)}' + x_{a'(b)}' + 2x_d'$$
 megohms per mile of circuit. (73)

(j) x_c of one conductor and earth.

$$x' = x_a' + \frac{1}{3} x_e'$$
 megohms per mile. (74)

In using the equations it should be remembered that the shunt capacitive reactance in megohms for more than one mile decreases because the capacitance increases. For more than one mile of line, therefore, the shunt-capacitive reactance as given by the above equations should be divided by the number of miles of line.

5. Conductor Temperature Rise and Current-Carrying Capacity

In distribution- and transmission-line design the temperature rise of conductors above ambient while carrying current is important. While power loss, voltage regulation, stability and other factors may determine the choice of a conductor for a given line, it is sometimes necessary to consider the maximum continuous current carrying capacity of a conductor. The maximum continuous current rating is necessary because it is determined by the maximum operating temperature of the conductor. This temperature affects the sag between towers or poles and determines the loss of conductor tensile strength due to annealing. For short tie lines or lines that must carry excessive loads under emergency conditions, the maximum continuous current-carrying capacity may be important in selecting the proper conductor.

The following discussion presents the Schurig and Frick⁶ formulas for calculating the approximate current-carrying capacity of conductors under known conditions of ambient temperature, wind velocity, and limiting temperature rise.

The basis of this method is that the heat developed in the conductor by I^2R loss is dissipated (1) by convection

in the surrounding air, and (2) radiation to surrounding objects. This can be expressed as follows:

$$I^2R = (W_c + W_r)A \text{ watts.} \quad (75)$$

where I = conductor current in amperes.

R = conductor resistance per foot.

W_c = watts per square inch dissipated by convection.

W_r = watts per square inch dissipated by radiation.

A = conductor surface area in square inches per foot of length.

The watts per square inch dissipated by convection, W_c , can be determined from the following equation:

$$W_c = \frac{0.0128 \sqrt{pv} \Delta t}{T_a^{0.123} \sqrt{d}} \text{ watts per square inch} \quad (76)$$

where p = pressure in atmospheres ($p=1.0$ for atmospheric pressure).

v = velocity in feet per second.

T_a = (degrees Kelvin) average of absolute temperatures of conductor and air.

d = outside diameter of conductor in inches.

Δt = (degrees C) temperature rise.

This formula is an approximation applicable to conductor diameters ranging from 0.3 inch to 5 inches or more when the velocity of air is higher than free convection air currents (0.2–0.5 ft./sec).

The watts per square inch dissipated by radiation, W_r , can be determined from the following equation:

$$W_r = 36.8E \left[\left(\frac{T}{1000} \right)^4 - \left(\frac{T_0}{1000} \right)^4 \right] \text{ watts per square inch}$$

where E = relative emissivity of conductor surface ($E=1.0$ for "black body," or 0.5 for average oxidized copper).

T = (degrees Kelvin) absolute temperature of conductor.

T_0 = (degrees Kelvin) absolute temperature of surroundings.

By calculating $(W_c + W_r)$, A , and R , it is then possible to determine I from Eq. (75). The value of R to use is the a-c resistance at the conductor temperature (ambient temperature plus temperature rise) taking into account skin effect as discussed previously in the section on positive- and negative-sequence resistances.

This method is, in general, applicable to both copper and aluminum conductors. Tests have shown that aluminum conductors dissipate heat at about the same rate as copper conductors of the same outside diameter when the temperature rise is the same. Where test data is available on conductors, it should be used. The above general method can be used when test data is not available, or to check test results.

The effect of the sun upon conductor temperature rise is generally neglected, being some 3° to 8°C. This small effect is less important under conditions of high temperature rise above ambient.⁶

The tables of Electrical Characteristics of Conductors include tabulations of the approximate maximum current-

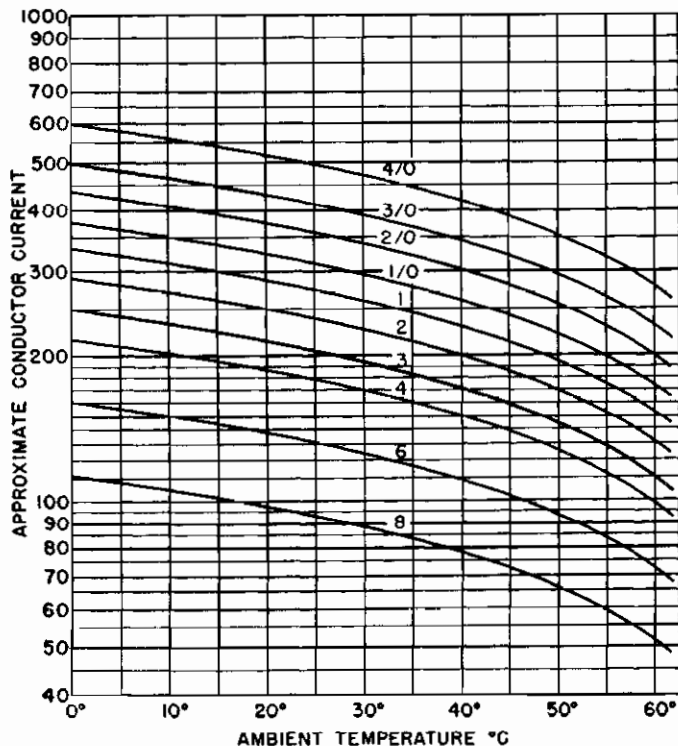

Fig. 25—Copper conductor current carrying capacity in Amperes VS. Ambient Temperature in °C. (Copper Conductors at 75°C, wind velocity at 2 fps.)

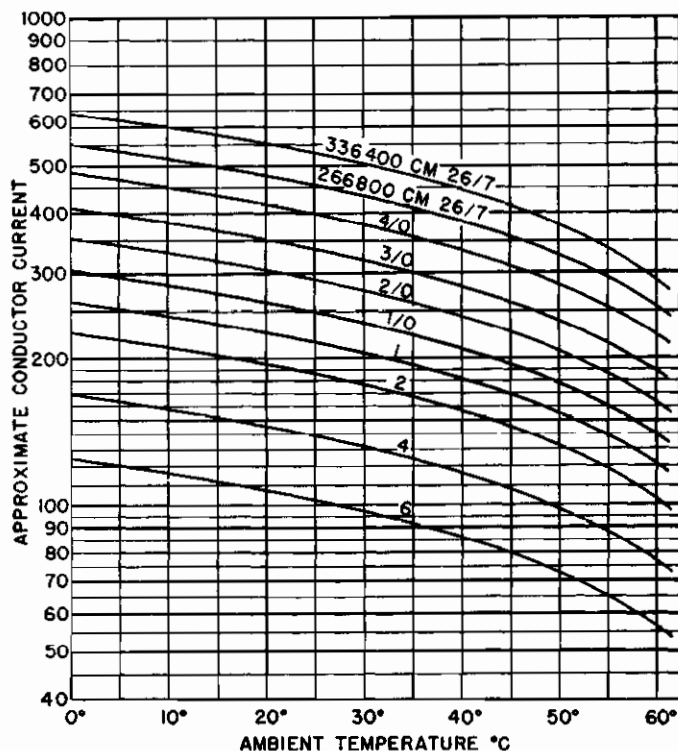

Fig. 26—Aluminum conductor current carrying capacity in Amperes VS. Ambient Temperature in °C. (Aluminum Conductors at 75°C, wind velocity at 2 fps.)



TABLE 1—CHARACTERISTICS OF COPPER CONDUCTORS, HARD DRAWN, 97.3 PERCENT CONDUCTIVITY

Circular Mils	A.W.G. or B. & S.	Number of Strands	Diam- eter of Indi- vidual Strands Inches	Out- side Diam- eter Inches	Break- ing Strength Pounds	Weight Pounds per Mile	Ap- prox. Cur- rent Carry- ing Capa- city* Amps	Geo- metric Mean Radius at 60 Cycles Feet	r_a Resistance Ohms per Conductor per Mile								x_a Inductive Reactance Ohms per Conductor Per Mile At 1 Ft. Spacing			x_a' Shunt Capacitive Reactance Megohms per Conductor Per Mile At 1 Ft. Spacing		
									25°C. (77°F.)				50°C. (122°F.)				25 cycles	50 cycles	60 cycles	25 cycles	50 cycles	60 cycles
									d-c	25 cycles	50 cycles	60 cycles	d-c	25 cycles	50 cycles	60 cycles						
1 000 000	...	37	0.1644	1.151	43 830	16 300	1 300	0.0368	0.0585	0.0594	0.0620	0.0634	0.0640	0.0648	0.0672	0.0685	0.1666	0.333	0.400	0.216	0.1081	0.0901
900 000	...	37	0.1560	1.092	39 510	14 670	1 220	0.0349	0.0650	0.0658	0.0682	0.0695	0.0711	0.0718	0.0740	0.0752	0.1693	0.339	0.406	0.220	0.1100	0.0916
800 000	...	37	0.1470	1.029	35 120	13 040	1 130	0.0329	0.0731	0.0739	0.0760	0.0772	0.0800	0.0806	0.0826	0.0837	0.1722	0.344	0.413	0.224	0.1121	0.0934
750 000	...	37	0.1424	0.997	33 400	12 230	1 090	0.0319	0.0780	0.0787	0.0807	0.0818	0.0853	0.0859	0.0878	0.0888	0.1739	0.348	0.417	0.226	0.1132	0.0943
700 000	...	37	0.1375	0.963	31 170	11 410	1 040	0.0308	0.0836	0.0842	0.0861	0.0871	0.0914	0.0920	0.0937	0.0947	0.1759	0.352	0.422	0.229	0.1145	0.0954
600 000	...	37	0.1273	0.891	27 020	9 781	940	0.0285	0.0975	0.0981	0.0997	0.1006	0.1066	0.1071	0.1084	0.1095	0.1799	0.360	0.432	0.235	0.1173	0.0977
500 000	...	37	0.1162	0.814	22 510	8 151	840	0.0260	0.1170	0.1175	0.1188	0.1196	0.1280	0.1283	0.1296	0.1303	0.1845	0.369	0.443	0.241	0.1205	0.1004
500 000	...	19	0.1622	0.811	21 590	8 151	840	0.0256	0.1170	0.1175	0.1188	0.1196	0.1280	0.1283	0.1296	0.1303	0.1853	0.371	0.445	0.241	0.1206	0.1005
450 000	...	19	0.1539	0.770	19 750	7 336	780	0.0243	0.1300	0.1304	0.1316	0.1323	0.1422	0.1426	0.1437	0.1443	0.1879	0.376	0.451	0.245	0.1224	0.1020
400 000	...	19	0.1451	0.726	17 560	6 521	730	0.0229	0.1462	0.1466	0.1477	0.1481	0.1600	0.1603	0.1613	0.1619	0.1909	0.382	0.458	0.249	0.1245	0.1038
350 000	...	19	0.1357	0.679	15 590	5 706	670	0.0211	0.1671	0.1675	0.1684	0.1690	0.1828	0.1831	0.1840	0.1845	0.1943	0.389	0.466	0.254	0.1260	0.1058
350 000	...	12	0.1708	0.710	15 140	5 706	670	0.0225	0.1671	0.1675	0.1684	0.1690	0.1828	0.1831	0.1840	0.1845	0.1918	0.384	0.460	0.251	0.1253	0.1044
300 000	...	19	0.1257	0.629	13 510	4 891	610	0.01987	0.1950	0.1953	0.1961	0.1966	0.213	0.214	0.214	0.215	0.1982	0.396	0.476	0.259	0.1266	0.1080
300 000	...	12	0.1581	0.657	13 170	4 891	610	0.0208	0.1950	0.1953	0.1961	0.1966	0.213	0.214	0.214	0.215	0.1957	0.392	0.470	0.256	0.1281	0.1068
250 000	...	19	0.1147	0.574	11 360	4 076	540	0.01813	0.234	0.234	0.235	0.235	0.256	0.256	0.257	0.257	0.203	0.406	0.487	0.260	0.1329	0.1108
250 000	...	12	0.1443	0.600	11 130	4 076	540	0.01902	0.234	0.234	0.235	0.235	0.256	0.256	0.257	0.257	0.200	0.401	0.481	0.263	0.1313	0.1094
211 600	4/0	19	0.1055	0.528	9 617	3 450	480	0.01668	0.276	0.277	0.277	0.278	0.302	0.303	0.303	0.303	0.207	0.414	0.497	0.272	0.1359	0.1132
211 600	4/0	12	0.1328	0.552	9 483	3 450	490	0.01750	0.276	0.277	0.277	0.278	0.302	0.303	0.303	0.303	0.205	0.409	0.491	0.260	0.1343	0.1119
211 600	4/0	7	0.1739	0.522	9 154	3 450	480	0.01579	0.276	0.277	0.277	0.278	0.302	0.303	0.303	0.303	0.210	0.420	0.503	0.273	0.1363	0.1136
167 800	3/0	12	0.1183	0.492	7 556	2 736	420	0.01559	0.349	0.349	0.349	0.350	0.381	0.381	0.382	0.382	0.210	0.421	0.505	0.277	0.1384	0.1153
167 800	3/0	7	0.1548	0.464	7 366	2 736	420	0.01404	0.349	0.349	0.349	0.350	0.381	0.381	0.382	0.382	0.216	0.431	0.518	0.281	0.1405	0.1171
133 100	2/0	7	0.1379	0.414	5 926	2 170	360	0.01252	0.440	0.440	0.440	0.440	0.481	0.481	0.481	0.481	0.222	0.443	0.532	0.289	0.1445	0.1205
105 500	1/0	7	0.1228	0.368	4 752	1 720	310	0.01113	0.555	0.555	0.555	0.555	0.606	0.607	0.607	0.607	0.227	0.455	0.546	0.298	0.1488	0.1240
83 690	1	7	0.1093	0.328	3 804	1 364	270	0.00992	0.699	0.699	0.699	0.699	0.765	0.765	0.765	0.765	0.233	0.467	0.560	0.306	0.1528	0.1274
83 690	1	3	0.1670	0.360	3 620	1 351	270	0.01016	0.692	0.692	0.692	0.692	0.757	0.757	0.757	0.757	0.232	0.464	0.557	0.299	0.1495	0.1246
66 370	2	7	0.0974	0.292	3 045	1 082	230	0.00883	0.881	0.882	0.882	0.882	0.964	0.964	0.964	0.964	0.239	0.478	0.574	0.314	0.1570	0.1308
66 370	2	3	0.1487	0.320	2 913	1 071	240	0.00903	0.873	0.882	0.882	0.882	0.955	0.955	0.955	0.955	0.238	0.476	0.571	0.307	0.1537	0.1281
66 370	2	1	0.258	0.258	3 003	1 061	220	0.00836	0.864	0.882	0.882	0.882	0.945	0.945	0.945	0.945	0.242	0.484	0.581	0.323	0.1614	0.1345
52 630	3	7	0.0867	0.260	2 433	858	200	0.00787	1.112	1.112	1.112	1.112	1.216	1.216	1.216	1.216	0.245	0.490	0.588	0.322	0.1611	0.1343
52 630	3	3	0.1325	0.285	2 359	850	200	0.00805	1.101	1.101	1.101	1.101	1.204	1.204	1.204	1.204	0.244	0.488	0.585	0.316	0.1578	0.1315
52 630	3	1	0.229	0.229	2 439	841	190	0.00745	1.090	1.090	1.090	1.090	1.192	1.192	1.192	1.192	0.248	0.496	0.595	0.331	0.1656	0.1380
41 740	4	3	0.1180	0.254	1 879	674	180	0.00717	1.388	1.388	1.388	1.388	1.518	1.518	1.518	1.518	0.250	0.499	0.599	0.324	0.1619	0.1349
41 740	4	1	0.204	0.204	1 970	667	170	0.00663	1.374	1.374	1.374	1.374	1.503	1.503	1.503	1.503	0.254	0.507	0.609	0.339	0.1697	0.1415
33 100	5	3	0.1050	0.226	1 505	534	150	0.00638	1.750	1.750	1.750	1.750	1.914	1.914	1.914	1.914	0.256	0.511	0.613	0.332	0.1661	0.1384
33 100	5	1	0.1819	0.1819	1 591	529	140	0.00590	1.723	1.723	1.723	1.723	1.895	1.895	1.895	1.895	0.260	0.519	0.623	0.348	0.1738	0.1449
26 250	6	3	0.0935	0.201	1 205	424	130	0.00568	2.21	2.21	2.21	2.21	2.41	2.41	2.41	2.41	0.262	0.523	0.628	0.341	0.1703	0.1419
26 250	6	1	0.1620	0.1620	1 280	420	120	0.00526	2.18	2.18	2.18	2.18	2.39	2.39	2.39	2.39	0.265	0.531	0.637	0.356	0.1790	0.1483
20 820	7	1	0.1443	0.1443	1 030	333	110	0.00468	2.75	2.75	2.75	2.75	3.01	3.01	3.01	3.01	0.271	0.542	0.651	0.364	0.1821	0.1517
16 510	8	1	0.1285	0.1285	826	264	90	0.00417	3.47	3.47	3.47	3.47	3.80	3.80	3.80	3.80	0.277	0.554	0.665	0.372	0.1862	0.1552

* For conductor at 75°C., air at 25°C., wind 1.4 miles per hour (2 ft/sec), frequency=60 cycles.

carrying capacity based on 50°C rise above an ambient of 25°C, (75°C total conductor temperature), tarnished surface ($E=0.5$), and an air velocity of 2 feet per second. These conditions were used after discussion and agreement with the conductor manufacturers. These thermal limitations are based on continuous loading of the conductors.

The technical literature shows little variation from these conditions as line design limits.⁷ The ambient air temperature is generally assumed to be 25°C to 40°C whereas the temperature rise is assumed to be 10°C to 60°C. This gives a conductor total temperature range of 35°C to 100°C. For design purposes copper or ACSR conductor total temperature is usually assumed to be 75°C as use of this value has given good conductor performance from an annealing standpoint, the limit being about 100°C where annealing of copper and aluminum begins.

Using Schurig and Frick's formulas, Fig. 25 and Fig. 26 have been calculated to show how current-carrying capacity of copper and aluminum conductors varies with ambient temperature assuming a conductor temperature of 75.C and wind velocity of 2 feet per second. These values are conservative and can be used as a guide in normal line design. For those lines where a higher conductor tem-

perature may be obtained that approaches 100°C, the conductor manufacturer should be consulted for test data or other more accurate information as to conductor temperature limitations. Such data on copper conductors has been presented rather thoroughly in the technical literature.⁷

III TABLES OF CONDUCTOR CHARACTERISTICS

The following tables contain data on copper, ACSR, hollow copper, Copperweld-copper, and Copperweld conductors, which along with the previously derived equations, permit the determination of positive-, negative-, and zero-sequence impedances of conductors for use in the solution of power-system problems. Also tabulated are such conductor characteristics as size, weight, and current-carrying capacity as limited by heating.

The conductor data (r_a , x_a , x_a') along with inductive and shunt-capacitive reactance spacing factors (x_a , x_d') and zero-sequence resistance, inductive and shunt-capacitive reactance factors (r_e , x_e , x_e') permit easy substitution in the previously derived equations for determining the symmetrical component sequence impedances of aerial circuits.

The cross-sectional inserts in the tables are for ease in

TABLE 3-A—CHARACTERISTICS OF ANACONDA HOLLOW COPPER CONDUCTORS

(Anaconda Wire & Cable Company)



Design Number	Size of Conductor Circular Mils or A.W.G.	Wires		Outside Diameter Inches	Breaking Strain Pounds	Weight Pounds per Mile	Geometric Mean Radius at 60 Cycles Feet	Approx. Current Carrying Capacity Amps†	r_a Resistance Ohms per Conductor per Mile				x_a Inductive Reactance Ohms per Conductor per Mile at 1 Ft. Spacing			x'_a Shunt Capacitive Reactance Megohms per Conductor per Mile at 1 Ft. Spacing					
		Number	Diameter Inches						25°C. (77°F.)		50°C. (122°F.)		25 cycles	50 cycles	60 cycles	25 cycles	50 cycles	60 cycles	25 cycles	50 cycles	60 cycles
									d-c	25 cycles	50 cycles	60 cycles									
966	890 500	28	0.1610	1.650	36 000	15 085	0.0612	1395	0.0671	0.0676	0.0734	0.0739	0.1412	0.282	0.339	0.1907	0.0953	0.0794			
969	750 000	42	0.1296	1.155	34 200	12 345	0.0408	1160	0.0786	0.0791	0.0860	0.0865	0.1617	0.323	0.388	0.216	0.1080	0.0960			
939	650 000	50	0.1097	1.126	29 500	10 761	0.0406	1060	0.0909	0.0915	0.0994	0.1001	0.1621	0.324	0.389	0.218	0.1089	0.0908			
360R1	600 000	50	0.1053	1.007	27 500	9 905	0.0387	1020	0.0984	0.0991	0.1077	0.1084	0.1644	0.329	0.395	0.221	0.1105	0.0921			
938	550 000	50	0.1009	1.036	25 200	9 103	0.0373	960	0.1076	0.1081	0.1177	0.1183	0.1663	0.333	0.399	0.224	0.1119	0.0932			
4R5	510 000	50	0.0970	1.000	22 700	8 485	0.0360	910	0.1173	0.1178	0.1283	0.1289	0.1681	0.336	0.404	0.226	0.1131	0.0943			
892R3	500 000	18	0.1558	1.080	21 400	8 263	0.0394	900	0.1178	0.1184	0.1289	0.1296	0.1630	0.326	0.391	0.221	0.1104	0.0920			
933	450 000	21	0.1353	1.074	19 300	7 476	0.0398	850	0.1319	0.1324	0.1443	0.1448	0.1630	0.326	0.391	0.221	0.1106	0.0922			
924	400 000	21	0.1227	1.014	17 200	6 612	0.0376	810	0.1485	0.1491	0.1624	0.1631	0.1658	0.332	0.398	0.225	0.1126	0.0939			
925R1	380 500	22	0.1211	1.003	16 300	6 331	0.0373	780	0.1565	0.1572	0.1712	0.1719	0.1663	0.333	0.399	0.226	0.1130	0.0942			
565R1	350 000	21	0.1196	0.950	15 100	5 813	0.0353	750	0.1695	0.1700	0.1854	0.1860	0.1691	0.338	0.406	0.230	0.1150	0.0958			
936	350 000	15	0.1444	0.860	15 400	5 778	0.0311	740	0.1690	0.1695	0.1849	0.1854	0.1754	0.351	0.421	0.237	0.1185	0.0988			
378R1	350 000	30	0.1059	0.736	16 100	5 739	0.0253	700	0.1685	0.1690	0.1843	0.1849	0.1860	0.372	0.446	0.248	0.1241	0.1034			
954	321 000	22	0.1113	0.920	13 850	5 343	0.0340	700	0.1851	0.1856	0.202	0.203	0.1710	0.342	0.410	0.232	0.1161	0.0968			
935	300 000	18	0.1205	0.839	13 100	4 984	0.0307	670	0.1980	0.1985	0.216	0.217	0.1761	0.352	0.423	0.239	0.1194	0.0995			
903R1	300 000	15	0.1338	0.797	13 200	4 953	0.0289	660	0.1969	0.1975	0.215	0.216	0.1793	0.359	0.430	0.242	0.1212	0.1010			
178R2	300 000	12	0.1507	0.750	13 050	4 937	0.0266	650	0.1964	0.1969	0.215	0.216	0.1833	0.367	0.440	0.247	0.1234	0.1028			
926	250 000	18	0.1100	0.766	10 950	4 155	0.0279	600	0.238	0.239	0.260	0.261	0.1810	0.362	0.434	0.245	0.1226	0.1022			
915R1	250 000	15	0.1214	0.725	11 000	4 148	0.0266	590	0.237	0.238	0.259	0.260	0.1834	0.367	0.440	0.249	0.1246	0.1038			
24R1	250 000	12	0.1368	0.683	11 000	4 133	0.0245	580	0.237	0.238	0.259	0.260	0.1876	0.375	0.450	0.253	0.1267	0.1066			
923	4/0	18	0.1005	0.700	9 300	3 521	0.0255	530	0.281	0.282	0.307	0.308	0.1855	0.371	0.445	0.252	0.1258	0.1049			
922	4/0	15	0.1109	0.663	9 300	3 510	0.0238	520	0.281	0.282	0.307	0.308	0.1889	0.378	0.453	0.256	0.1278	0.1065			
50R2	4/0	14	0.1152	0.650	9 300	3 510	0.0234	520	0.280	0.281	0.306	0.307	0.1898	0.380	0.455	0.257	0.1285	0.1071			
158R1	3/0	16	0.0961	0.606	7 500	2 785	0.0221	460	0.354	0.355	0.387	0.388	0.1928	0.386	0.463	0.262	0.1310	0.1091			
495R1	3/0	15	0.0996	0.595	7 600	2 785	0.0214	460	0.353	0.354	0.386	0.387	0.1943	0.389	0.466	0.263	0.1316	0.1097			
570R2	3/0	12	0.1123	0.560	7 600	2 772	0.0201	450	0.352	0.353	0.385	0.386	0.1976	0.395	0.474	0.268	0.1338	0.1115			
909R2	2/0	15	0.0880	0.530	5 950	2 213	0.0191	370	0.446	0.446	0.487	0.487	0.200	0.400	0.481	0.271	0.1357	0.1131			
412R2	2/0	14	0.0913	0.515	6 000	2 207	0.0184	370	0.446	0.446	0.487	0.487	0.202	0.404	0.485	0.274	0.1368	0.1140			
937	2/0	13	0.0950	0.505	6 000	2 203	0.0181	370	0.446	0.446	0.487	0.487	0.203	0.406	0.487	0.275	0.1375	0.1146			
930	125 600	14	0.0885	0.500	5 650	2 083	0.0180	360	0.473	0.473	0.517	0.517	0.203	0.406	0.487	0.276	0.1378	0.1149			
934	121 300	15	0.0836	0.500	5 400	2 015	0.0179	350	0.491	0.491	0.537	0.537	0.203	0.407	0.488	0.276	0.1378	0.1149			
901	119 400	12	0.0936	0.470	5 300	1 979	0.0165	340	0.507	0.507	0.555	0.555	0.207	0.415	0.498	0.280	0.1400	0.1167			

†For conductor at 75°C., air at 25°C., wind 1.4 miles per hour (2 ft/sec), frequency=60 cycles, average tarnished surface.

TABLE 3-B—CHARACTERISTICS OF GENERAL CABLE TYPE HH HOLLOW COPPER CONDUCTORS

(General Cable Corporation)



Conductor Size Circular Mils or A.W.G.	Out-side ⁽¹⁾ Diameter Inches	Wall Thickness Inches	Weight Pounds per Mile	Breaking Strength Pounds	Geometric Mean Radius Feet	Approx. Current Carrying Capacity ⁽²⁾ Amps	r_a Resistance Ohms per Conductor per Mile								x_a Inductive Reactance Ohms per Conductor per Mile at 1 Foot Spacing			x'_a Shunt Capacitive Reactance Megohms per Conductor per Mile at 1 Foot Spacing		
							25°C. (77°F.)				50°C. (122°F.)				25 cycles	50 cycles	60 cycles	25 cycles	50 cycles	60 cycles
							d-c	25 cycles	50 cycles	60 cycles	d-c	25 cycles	50 cycles	60 cycles						
1 000 000	2 103	0.150*	16 160	43 190	0.0833	1620	0.0576	0.0576	0.0577	0.0577	0.0630	0.0630	0.0631	0.0631	0.1257	0.251	0.302	0.1734	0.0867	0.0722
950 000	2 035	0.147*	15 350	41 030	0.0805	1565	0.0606	0.0606	0.0607	0.0607	0.0663	0.0664	0.0664	0.0664	0.1274	0.255	0.306	0.1757	0.0879	0.0732
900 000	1 966	0.144*	14 540	38 870	0.0778	1505	0.0640	0.0640	0.0641	0.0641	0.0700	0.0701	0.0701	0.0701	0.1291	0.258	0.310	0.1782	0.0891	0.0742
850 000	1 901	0.140*	13 730	36 710	0.0751	1450	0.0677	0.0678	0.0678	0.0678	0.0741	0.0742	0.0742	0.0742	0.1309	0.262	0.314	0.1805	0.0903	0.0752
800 000	1 820	0.137*	12 920	34 550	0.0722	1390	0.0720	0.0720	0.0720	0.0721	0.0788	0.0788	0.0788	0.0788	0.1329	0.266	0.319	0.1833	0.0917	0.0764
790 000	1 650	0.131†	12 760	34 120	0.0646	1335	0.0729	0.0729	0.0730	0.0730	0.0797	0.0798	0.0799	0.0799	0.1385	0.277	0.332	0.1906	0.0953	0.0794
750 000	1 750	0.133*	12 120	32 390	0.0691	1325	0.0768	0.0768	0.0768	0.0769	0.0840	0.0840	0.0841	0.0841	0.1351	0.270	0.324	0.1864	0.0932	0.0777
700 000	1 686	0.130*	11 310	30 230	0.0665	1265	0.0822	0.0823	0.0823	0.0823	0.0900	0.0900	0.0901	0.0901	0.1370	0.274	0.329	0.1891	0.0945	0.0788
650 000	1 610	0.126*	10 500	28 070	0.0635	1200	0.0886	0.0886	0.0886	0.0887	0.0969	0.0970	0.0970	0.0970	0.1394	0.279	0.335	0.1924	0.0962	0.0802
600 000	1 558	0.123*	9 692	25 910	0.0615	1140	0.0959	0.0960	0.0960	0.0960	0.1050	0.1051	0.1051	0.1051	0.1410	0.282	0.338	0.1947	0.0974	0.0811
550 000	1 478	0.119*	8 884	23 750	0.0582	1075	0.1047	0.1048	0.1048	0.1048	0.1146	0.1146	0.1147	0.1147	0.1437	0.287	0.345	0.1985	0.0992	0.0827
512 000	1 400	0.115*	8 270	22 110	0.0551	1020	0.1124	0.1125	0.1125	0.1125	0.1230	0.1230	0.1231	0.1231	0.1466	0.293	0.352	0.202	0.1012	0.0843
500 000	1 390	0.115*	8 076	21 590	0.0547	1005	0.1151	0.1151	0.1152	0.1152	0.1259	0.1260	0.1260	0.1260	0.1469	0.294	0.353	0.203	0.1014	0.0845
500 000	1 268	0.109†	8 074	21 590	0.0494	978	0.1151	0.1152	0.1152	0.1152	0.1259	0.1260	0.1260	0.1261	0.1521	0.304	0.365	0.209	0.1047	0.0872
500 000	1 100	0.130†	8 068	21 590	0.0420	937	0.1150	0.1151	0.1152	0.1152	0.1258	0.1259	0.1260	0.1260	0.1603	0.321	0.385	0.219	0.1098	0.0915
500 000																				

TABLE 4-A—CHARACTERISTICS OF COPPERWELD-COPPER CONDUCTORS

(Copperweld Steel Company)

Nominal Designation	Size of Conductor			Copper Equivalent Circular Mils or A.W.G.	Rated Breaking Load Lbs.	Weight Lbs. per Mile	Geometric Mean Radius at 60 Cycles Feet	Approx. Current Carrying Capacity at 60 Cycles Amps*	r_a Resistance				r_a Resistance				X_a Inductive Reactance			X_a' Capacitive Reactance		
	Number and Diameter of Wires		Outside Diameter Inches						Resistance Ohms per Conductor per Mile at 25°C. (77°F.) Small Currents			Resistance Ohms per Conductor per Mile at 50°C. (122°F.) Current Approx. 75% of Capacity**			Ohms per Mile			Reactance Megohms per Conductor per Mile One ft. Spacing				
	Copper-weld	Copper							d-c	25 cycles	50 cycles	60 cycles	d-c	25 cycles	50 cycles	60 cycles	25 cycles	50 cycles	60 cycles	25 cycles	50 cycles	60 cycles
350 E	7x 1576"	12x 1576"	0.788	350 000	32 420	7 409	0.0220	660	0.1658	0.1728	0.1780	0.1812	0.1812	0.1915	0.201	0.204	0.1929	0.386	0.463	0.243	0.1216	0.1014
350 EK	1x 1470"	15x 1470"	0.735	350 000	23 850	6 536	0.0245	680	0.1658	0.1682	0.1700	0.1705	0.1812	0.1845	0.1873	0.1882	0.1875	0.375	0.450	0.248	0.1241	0.1034
350 V	3x 1751"	9x 1893"	0.754	350 000	23 480	6 578	0.0226	650	0.1655	0.1725	0.1800	0.1828	0.1809	0.1910	0.202	0.206	0.1915	0.383	0.460	0.246	0.1232	0.1027
300 E	7x 1459"	12x 1459"	0.729	300 000	27 770	6 351	0.0204	600	0.1934	0.200	0.207	0.209	0.211	0.222	0.232	0.235	0.1969	0.394	0.473	0.249	0.1244	0.1037
300 EK	4x 1561"	15x 1361"	0.680	300 000	20 960	5 602	0.0227	610	0.1934	0.1958	0.1976	0.1981	0.211	0.215	0.218	0.219	0.1914	0.383	0.460	0.251	0.1269	0.1057
300 V	3x 1621"	9x 1752"	0.698	300 000	20 730	5 639	0.0209	590	0.1930	0.200	0.208	0.210	0.211	0.222	0.233	0.237	0.1954	0.391	0.469	0.252	0.1259	0.1050
250 E	7x 1332"	12x 1332"	0.666	250 000	23 920	5 292	0.01859	540	0.232	0.239	0.245	0.248	0.254	0.265	0.275	0.279	0.202	0.403	0.484	0.255	0.1276	0.1064
250 EK	4x 1242"	15x 1242"	0.621	250 000	17 840	4 669	0.0207	540	0.232	0.235	0.236	0.237	0.254	0.258	0.261	0.261	0.1960	0.392	0.471	0.260	0.1301	0.1084
250 V	3x 1480"	9x 1600"	0.637	250 000	17 420	4 699	0.01911	530	0.232	0.239	0.246	0.249	0.253	0.264	0.276	0.281	0.200	0.400	0.480	0.258	0.1292	0.1077
4/0 E	7x 1225"	12x 1225"	0.613	4/0	20 730	4 479	0.01711	480	0.274	0.281	0.287	0.290	0.300	0.312	0.323	0.326	0.206	0.411	0.493	0.261	0.1306	0.1088
4/0 G	3x 1941"	5x 1941"	0.583	4/0	15 640	4 168	0.01409	460	0.274	0.281	0.291	0.298	0.299	0.318	0.336	0.342	0.215	0.431	0.517	0.268	0.1341	0.1118
4/0 EK	4x 1143"	15x 1143"	0.571	4/0	15 370	3 951	0.01903	490	0.274	0.277	0.278	0.279	0.300	0.304	0.307	0.308	0.200	0.401	0.481	0.266	0.1331	0.1109
4/0 V	3x 1361"	9x 1472"	0.586	4/0	15 000	3 977	0.01758	470	0.274	0.281	0.288	0.291	0.299	0.311	0.323	0.328	0.204	0.409	0.490	0.264	0.1322	0.1101
4/0 F	1x 1833"	6x 1833"	0.550	4/0	12 290	3 750	0.01558	470	0.273	0.280	0.285	0.287	0.299	0.309	0.318	0.322	0.210	0.421	0.505	0.269	0.1341	0.1120
3/0 E	7x 1091"	12x 1091"	0.545	3/0	16 800	3 552	0.01521	420	0.316	0.353	0.359	0.361	0.378	0.391	0.402	0.407	0.212	0.423	0.508	0.270	0.1348	0.1123
3/0 G	3x 1851"	5x 1851"	0.515	3/0	16 170	3 732	0.01156	410	0.314	0.356	0.367	0.372	0.377	0.398	0.419	0.428	0.225	0.451	0.511	0.268	0.1341	0.1118
3/0 G	2x 1731"	2x 1731"	0.519	3/0	12 860	3 305	0.01254	400	0.311	0.355	0.365	0.369	0.377	0.397	0.416	0.423	0.221	0.443	0.531	0.273	0.1365	0.1137
3/0 EK	4x 1018"	4x 1018"	0.509	3/0	12 370	3 134	0.01697	420	0.316	0.348	0.350	0.351	0.378	0.382	0.386	0.386	0.206	0.412	0.495	0.271	0.1372	0.1143
3/0 V	3x 1311"	9x 1311"	0.522	3/0	12 220	3 154	0.01566	410	0.345	0.352	0.360	0.362	0.377	0.390	0.403	0.408	0.210	0.420	0.504	0.273	0.1363	0.1136
3/0 F	1x 1632"	6x 1632"	0.490	3/0	9 980	2 974	0.01388	410	0.344	0.351	0.356	0.358	0.377	0.388	0.397	0.401	0.216	0.432	0.519	0.277	0.1385	0.1155
2/0 K	4x 1780"	3x 1780"	0.534	2/0	17 600	3 411	0.00912	360	0.431	0.417	0.459	0.466	0.475	0.499	0.524	0.535	0.237	0.475	0.570	0.271	0.1355	0.1129
2/0 J	3x 1648"	4x 1648"	0.494	2/0	13 430	2 900	0.01029	350	0.434	0.446	0.457	0.462	0.475	0.498	0.520	0.530	0.231	0.463	0.555	0.277	0.1383	0.1152
2/0 G	2x 1542"	5x 1542"	0.463	2/0	10 510	2 622	0.01119	350	0.431	0.445	0.456	0.459	0.475	0.497	0.518	0.525	0.227	0.454	0.545	0.281	0.1406	0.1171
2/0 V	3x 1080"	9x 1167"	0.465	2/0	9 846	2 502	0.01395	360	0.435	0.442	0.450	0.452	0.476	0.489	0.504	0.509	0.216	0.432	0.518	0.281	0.1404	0.1170
2/0 F	1x 1454"	6x 1454"	0.436	2/0	8 094	2 359	0.01235	350	0.434	0.441	0.446	0.448	0.475	0.487	0.497	0.501	0.222	0.444	0.533	0.285	0.1427	0.1189
1/0 K	4x 1585"	3x 1585"	0.475	1/0	14 490	2 703	0.00812	310	0.548	0.560	0.573	0.579	0.599	0.625	0.652	0.664	0.243	0.487	0.584	0.279	0.1397	0.1164
1/0 J	3x 1467"	4x 1467"	0.440	1/0	10 970	2 346	0.00917	310	0.548	0.559	0.570	0.576	0.599	0.624	0.648	0.659	0.237	0.474	0.569	0.285	0.1423	0.1186
1/0 G	2x 1373"	5x 1373"	0.412	1/0	8 563	2 078	0.00996	310	0.518	0.559	0.568	0.573	0.599	0.623	0.645	0.654	0.233	0.466	0.559	0.289	0.1447	0.1206
1/0 F	1x 1294"	6x 1294"	0.388	1/0	6 536	1 870	0.01099	310	0.548	0.554	0.559	0.562	0.599	0.612	0.622	0.627	0.228	0.456	0.547	0.294	0.1469	0.1224
1 N	5x 1546"	2x 1546"	0.461	1	15 410	2 541	0.00638	280	0.691	0.705	0.719	0.726	0.755	0.787	0.818	0.832	0.256	0.512	0.614	0.281	0.1405	0.1171
1 K	4x 1412"	3x 1412"	0.423	1	11 900	2 144	0.00723	270	0.691	0.704	0.716	0.722	0.755	0.784	0.813	0.825	0.249	0.498	0.598	0.288	0.1438	0.1198
1 J	3x 1307"	4x 1307"	0.392	1	9 000	1 861	0.00817	270	0.691	0.703	0.714	0.719	0.755	0.783	0.808	0.820	0.243	0.486	0.583	0.293	0.1465	0.1221
1 G	2x 1222"	5x 1222"	0.367	1	6 956	1 619	0.00887	260	0.691	0.702	0.712	0.716	0.755	0.781	0.805	0.815	0.239	0.478	0.573	0.298	0.1488	0.1240
1 F	1x 1153"	6x 1153"	0.346	1	5 266	1 483	0.00980	270	0.691	0.698	0.704	0.705	0.755	0.769	0.781	0.786	0.234	0.468	0.561	0.302	0.1509	0.1258
2 P	6x 1540"	1x 1540"	0.462	2	16 870	2 487	0.00501	250	0.871	0.886	0.901	0.909	0.952	0.988	1.024	1.040	0.268	0.536	0.643	0.281	0.1406	0.1172
2 N	5x 1377"	2x 1377"	0.413	2	12 680	2 015	0.00568	240	0.871	0.885	0.899	0.906	0.952	0.986	1.020	1.035	0.261	0.523	0.627	0.289	0.1446	0.1205
2 K	4x 1257"	3x 1257"	0.377	2	9 730	1 701	0.00644	240	0.871	0.884	0.896	0.902	0.952	0.983	1.014	1.028	0.255	0.510	0.612	0.296	0.1479	0.1232
2 J	3x 1164"	4x 1164"	0.349	2	7 322	1 478	0.00727	230	0.871	0.883	0.894	0.899	0.952	0.982	1.010	1.022	0.249	0.498	0.598	0.301	0.1506	0.1255
2 A	1x 1699"	2x 1699"	0.366	2	5 876	1 358	0.00763	240	0.869	0.875	0.880	0.882	0.950	0.962	0.973	0.979	0.247	0.493	0.592	0.298	0.1489	0.1241
2 G	2x 1089"	5x 1089"	0.327	2	5 626	1 307	0.00790	230	0.871	0.882	0.892	0.896	0.952	0.980	1.006	1.016	0.245	0.489	0.587	0.306	0.1529	0.1275
2 F	1x 1026"	6x 1026"	0.308	2	4 233	1 176	0.00873	230	0.871	0.878	0.884	0.885	0.952	0.967	0.979	0.985	0.230	0.479	0.575	0.310	0.1551	0.1292
3 P	6x 1371"	1x 1371"	0.411	3	13 910	1 973	0.00445	220	1.098	1.113	1.127	1.136	1.200	1.239	1.273	1.296	0.274	0.547	0.657	0.290	0.1448	0.1207
3 N	5x 1226"	2x 1226"	0.368	3	10 390	1 598	0.00506	210	1.098	1.112	1.126	1.133	1.200	1.237	1.273	1.289	0.267	0.534	0.641	0.298	0.1487	0.1239
3 K	4x 1120"	3x 1120"	0.336	3	7 910	1 349	0.00574	210	1.098	1.111	1.123	1.129	1.200	1.233	1.267	1.281	0.261	0.522	0.626	0.304	0.1520	0.1266
3 J	3x 1036"																					

TABLE 4-B—CHARACTERISTICS OF COPPERWELD CONDUCTORS
(Copperweld Steel Company)



Nominal Conductor Size	Number and Size of Wires	Outside Diameter Inches	Area of Conductor Circular Mils	Rated Breaking Load Pounds		Weight Pounds per Mile	Geometric Mean Radius at 60 cycles and Average Currents Feet	Approx. Current Carrying Capacity* Amps at 60 Cycles	r_a Resistance Ohms per Conductor per Mile at 25°C. (77°F.) Small Currents			r_a Resistance Ohms per Conductor per Mile at 75°C. (167°F.) Current Approx. 75% of Capacity**			x_a Inductive Reactance Ohms per Conductor per Mile One Ft. Spacing Average Currents			x_a' Capacitive Reactance Megohms per Conductor per Mile One Ft. Spacing				
				Strength					d-c	25 cycles	50 cycles	60 cycles	d-c	25 cycles	50 cycles	60 cycles	25 cycles	50 cycles	60 cycles	25 cycles	50 cycles	60 cycles
				High	Extra High																	
30% Conductivity																						
7/8"	19 No. 5	0.910	628 900	55 570	66 910	9 344	0.00758	620	0.306	0.316	0.326	0.331	0.363	0.419	0.476	0.499	0.261	0.493	0.592	0.233	0.1165	0.0971
13/16"	19 No. 6	0.810	498 800	45 830	55 530	7 410	0.00675	540	0.386	0.396	0.406	0.411	0.458	0.518	0.580	0.605	0.267	0.505	0.606	0.241	0.1206	0.1005
23/32"	19 No. 7	0.721	395 500	37 740	45 850	5 877	0.00601	470	0.486	0.496	0.506	0.511	0.577	0.643	0.710	0.737	0.273	0.517	0.621	0.250	0.1248	0.1040
21/32"	19 No. 8	0.642	313 700	31 040	37 690	4 660	0.00535	410	0.613	0.623	0.633	0.638	0.728	0.799	0.872	0.902	0.279	0.529	0.635	0.258	0.1289	0.1074
9/16"	19 No. 9	0.572	248 800	25 500	30 610	3 696	0.00477	360	0.773	0.783	0.793	0.798	0.917	0.995	1.075	1.106	0.285	0.541	0.649	0.266	0.1330	0.1109
5/8"	7 No. 4	0.613	292 200	24 780	29 430	4 324	0.00511	410	0.556	0.664	0.672	0.676	0.778	0.824	0.870	0.887	0.281	0.533	0.640	0.261	0.1306	0.1088
9/16"	7 No. 5	0.546	231 700	20 470	24 650	3 429	0.00455	360	0.827	0.835	0.843	0.847	0.981	1.030	1.080	1.099	0.287	0.545	0.654	0.269	0.1347	0.1122
1/2"	7 No. 6	0.486	183 800	16 890	20 460	2 719	0.00405	310	1.012	1.050	1.058	1.062	1.237	1.290	1.343	1.364	0.293	0.557	0.668	0.278	0.1388	0.1157
7/16"	7 No. 7	0.433	145 700	13 910	16 890	2 157	0.00361	270	1.315	1.323	1.331	1.335	1.560	1.617	1.675	1.697	0.299	0.569	0.683	0.286	0.1429	0.1191
3/8"	7 No. 8	0.385	115 600	11 440	13 890	1 710	0.00321	230	1.658	1.666	1.671	1.678	1.967	2.03	2.09	2.12	0.305	0.581	0.697	0.294	0.1471	0.1226
9/16"	7 No. 9	0.343	91 650	9 393	11 290	1 356	0.00286	200	2.09	2.10	2.11	2.11	2.48	2.55	2.61	2.64	0.311	0.592	0.711	0.303	0.1512	0.1260
5/16"	7 No. 10	0.306	72 680	7 758	9 196	1 076	0.00255	170	2.64	2.64	2.65	2.66	3.13	3.20	3.27	3.30	0.316	0.604	0.725	0.311	0.1553	0.1294
3 No. 5	3 No. 5	0.392	99 310	9 262	11 860	1 467	0.00457	220	1.926	1.931	1.936	1.938	2.29	2.31	2.34	2.35	0.299	0.545	0.654	0.293	0.1465	0.1221
3 No. 6	3 No. 6	0.349	78 750	7 639	9 754	1 163	0.00407	190	2.43	2.43	2.44	2.44	2.88	2.91	2.94	2.95	0.295	0.556	0.668	0.301	0.1506	0.1255
3 No. 7	3 No. 7	0.311	62 450	6 291	7 922	922	0.00363	160	3.06	3.07	3.07	3.07	3.63	3.66	3.70	3.71	0.301	0.568	0.682	0.310	0.1547	0.1289
3 No. 8	3 No. 8	0.277	49 530	5 174	6 282	731	0.00323	140	3.86	3.87	3.87	3.87	4.58	4.61	4.65	4.66	0.307	0.580	0.696	0.318	0.1589	0.1324
3 No. 9	3 No. 9	0.247	39 290	4 250	5 129	580	0.00288	120	4.87	4.87	4.88	4.88	5.78	5.81	5.85	5.86	0.313	0.591	0.710	0.326	0.1629	0.1358
3 No. 10	3 No. 10	0.220	31 150	3 509	4 160	460	0.00257	110	6.14	6.14	6.15	6.15	7.28	7.32	7.36	7.38	0.319	0.603	0.724	0.334	0.1671	0.1392
40% Conductivity																						
7/8"	19 No. 5	0.910	628 900	50 240	9 344	0.01175	690	0.229	0.239	0.249	0.254	0.272	0.321	0.371	0.391	0.236	0.449	0.539	0.233	0.1165	0.0971
13/16"	19 No. 6	0.810	498 800	41 600	7 410	0.01046	610	0.289	0.299	0.309	0.314	0.343	0.396	0.450	0.472	0.241	0.461	0.553	0.241	0.1206	0.1005
23/32"	19 No. 7	0.721	395 500	34 390	5 877	0.00931	530	0.365	0.375	0.385	0.390	0.433	0.490	0.549	0.573	0.247	0.473	0.567	0.250	0.1248	0.1040
21/32"	19 No. 8	0.642	313 700	28 380	4 660	0.00829	470	0.460	0.470	0.480	0.485	0.546	0.608	0.672	0.698	0.253	0.485	0.582	0.258	0.1289	0.1074
9/16"	19 No. 9	0.572	248 800	23 390	3 696	0.00739	410	0.590	0.590	0.600	0.605	0.688	0.756	0.826	0.853	0.259	0.496	0.595	0.266	0.1330	0.1109
5/8"	7 No. 4	0.613	292 200	22 310	4 324	0.00792	470	0.492	0.500	0.508	0.512	0.584	0.624	0.664	0.680	0.259	0.489	0.587	0.261	0.1306	0.1088
9/16"	7 No. 5	0.546	231 700	18 510	3 429	0.00705	410	0.620	0.628	0.636	0.640	0.738	0.780	0.843	0.840	0.261	0.501	0.601	0.269	0.1347	0.1122
1/2"	7 No. 6	0.486	183 800	15 330	2 719	0.00628	350	0.782	0.790	0.798	0.802	0.928	0.975	1.021	1.040	0.267	0.513	0.615	0.278	0.1388	0.1157
7/16"	7 No. 7	0.433	145 700	12 670	2 157	0.00559	310	0.986	0.994	1.002	1.006	1.170	1.220	1.271	1.291	0.273	0.524	0.629	0.286	0.1429	0.1191
3/8"	7 No. 8	0.385	115 600	10 460	1 710	0.00497	270	1.244	1.252	1.260	1.264	1.476	1.530	1.584	1.606	0.279	0.536	0.644	0.294	0.1471	0.1226
9/16"	7 No. 9	0.343	91 650	8 616	1 356	0.00443	230	1.568	1.576	1.584	1.588	1.861	1.919	1.978	2.00	0.285	0.548	0.658	0.303	0.1512	0.1260
5/16"	7 No. 10	0.306	72 680	7 121	1 076	0.00395	200	1.978	1.986	1.994	1.998	2.35	2.41	2.47	2.50	0.291	0.559	0.671	0.311	0.1553	0.1294
3 No. 5	3 No. 5	0.392	99 310	8 373	1 167	0.00621	250	1.445	1.450	1.455	1.457	1.714	1.738	1.762	1.772	0.269	0.514	0.617	0.293	0.1465	0.1221
3 No. 6	3 No. 6	0.349	78 750	6 934	1 163	0.00553	220	1.821	1.826	1.831	1.833	2.16	2.19	2.21	2.22	0.275	0.526	0.631	0.301	0.1506	0.1255
3 No. 7	3 No. 7	0.311	62 450	5 732	922	0.00492	190	2.30	2.30	2.31	2.31	2.73	2.75	2.78	2.79	0.281	0.537	0.645	0.310	0.1547	0.1289
3 No. 8	3 No. 8	0.277	49 530	4 730	731	0.00439	160	2.90	2.90	2.91	2.91	3.44	3.47	3.50	3.51	0.286	0.549	0.659	0.318	0.1589	0.1324
3 No. 9	3 No. 9	0.247	39 290	3 898	580	0.00391	140	3.65	3.66	3.66	3.66	4.33	4.37	4.40	4.41	0.292	0.561	0.673	0.326	0.1629	0.1358
3 No. 10	3 No. 10	0.220	31 150	3 221	460	0.00348	120	4.61	4.61	4.62	4.62	5.46	5.50	5.53	5.55	0.297	0.572	0.687	0.334	0.1671	0.1392
3 No. 12	3 No. 12	0.174	19 590	2 236	289	0.00276	90	7.32	7.33	7.33	7.31	8.69	8.73	8.77	8.78	0.310	0.596	0.715	0.351	0.1754	0.1462

*Based on conductor temperature of 125°C. and an ambient of 25°C.
 **Resistance at 75°C. total temperature, based on an ambient of 25°C. plus 50°C. rise due to heating effect of current.
 The approximate magnitude of current necessary to produce the 50°C. rise is 75% of the "Approximate Current Carrying Capacity at 60 Cycles."

TABLE 5—SKIN EFFECT TABLE

X	K	X	K	X	K	X	K
0.0	1.00000	1.0	1.00519	2.0	1.07816	3.0	1.31809
0.1	1.00000	1.1	1.00758	2.1	1.09375	3.1	1.35102
0.2	1.00001	1.2	1.01071	2.2	1.11126	3.2	1.38504
0.3	1.00004	1.3	1.01470	2.3	1.13069	3.3	1.41999
0.4	1.00013	1.4	1.01969	2.4	1.15207	3.4	1.45570
0.5	1.00032	1.5	1.02582	2.5	1.17538	3.5	1.49202
0.6	1.00067	1.6	1.03323	2.6	1.20056	3.6	1.52879
0.7	1.00124	1.7	1.04205	2.7	1.22753	3.7	1.56587
0.8	1.00212	1.8	1.05240	2.8	1.25620	3.8	1.60314
0.9	1.00340	1.9	1.06440	2.9	1.28644	3.9	1.64051

TABLE 6—INDUCTIVE REACTANCE SPACING FACTOR (x_d) OHMS PER CONDUCTOR PER MILE

25 CYCLES

		SEPARATION											
		INCHES											
Feet		0	1	2	3	4	5	6	7	8	9	10	11
0	-	-0.1256	-0.0906	-0.0701	-0.0555	-0.0443	-0.0350	-0.0273	-0.0205	-0.0145	-0.0092	-0.0044	
1	0	0.0040	0.0078	0.0113	0.0145	0.0176	0.0205	0.0232	0.0258	0.0283	0.0306	0.0329	
2	0.0350	0.0371	0.0391	0.0410	0.0428	0.0446	0.0463	0.0480	0.0496	0.0511	0.0527	0.0541	
3	0.0555	0.0569	0.0583	0.0596	0.0609	0.0621	0.0633	0.0645	0.0657	0.0668	0.0679	0.0690	
4	0.0701	0.0711	0.0722	0.0732	0.0741	0.0751	0.0760	0.0770	0.0779	0.0788	0.0797	0.0805	
5	0.0814	0.0822	0.0830	0.0838	0.0846	0.0854	0.0862	0.0869	0.0877	0.0884	0.0892	0.0899	
6	0.0906	0.0913	0.0920	0.0927	0.0933	0.0940	0.0946	0.0953	0.0959	0.0965	0.0972	0.0978	
7	0.0984	0.0990	0.0996	0.1002	0.1007	0.1013	0.1019	0.1024	0.1030	0.1035	0.1041	0.1046	
8	0.1051												
9	0.1111												
10	0.1164												

x_d at
25 cycles
 $x_d = 0.1164 \log_{10} d$
 $d = \text{separation, feet.}$

FUNDAMENTAL EQUATIONS
 $x_1 = x_2 = r_a + j(x_a + x_d)$
 $x_o = r_a + r_e + j(x_a + x_e - 2x_d)$

50 CYCLES

		SEPARATION											
		Inches											
Feet		0	1	2	3	4	5	6	7	8	9	10	11
10	0.1164												
11	0.1212												
12	0.1256												
13	0.1297												
14	0.1334												
15	0.1369												
16	0.1402												
17	0.1432												
18	0.1461	0	-0.2513	-0.1812	-0.1402	-0.1111	-0.0885	-0.0701	-0.0545	-0.0410	-0.0291	-0.0184	-0.0088
19	0.1489	1	0	0.0081	0.0156	0.0226	0.0291	0.0352	0.0410	0.0465	0.0517	0.0566	0.0613
20	0.1515	2	0.0701	0.0742	0.0782	0.0820	0.0857	0.0892	0.0927	0.0960	0.0992	0.1023	0.1053
21	0.1539	3	0.1111	0.1139	0.1166	0.1192	0.1217	0.1242	0.1267	0.1291	0.1314	0.1337	0.1359
22	0.1563	4	0.1402	0.1423	0.1443	0.1463	0.1483	0.1502	0.1521	0.1539	0.1558	0.1576	0.1593
23	0.1585	5	0.1627	0.1644	0.1661	0.1677	0.1693	0.1708	0.1724	0.1739	0.1754	0.1769	0.1783
24	0.1607	6	0.1812	0.1826	0.1839	0.1853	0.1866	0.1880	0.1893	0.1906	0.1918	0.1931	0.1943
25	0.1627	7	0.1968	0.1980	0.1991	0.2003	0.2015	0.2026	0.2037	0.2049	0.2060	0.2071	0.2081
26	0.1647	8	0.2103										
27	0.1666	9	0.2222										
28	0.1685	10	0.2328										
29	0.1702	11	0.2425										

x_d at
50 cycles
 $x_d = 0.2328 \log_{10} d$
 $d = \text{separation, feet.}$

60 CYCLES

		SEPARATION											
		Inches											
Feet		0	1	2	3	4	5	6	7	8	9	10	11
30	0.1720	12	0.2513										
31	0.1736	13	0.2594										
32	0.1752	14	0.2669										
33	0.1768	15	0.2738										
34	0.1783	16	0.2804										
35	0.1798	17	0.2865										
36	0.1812	18	0.2923	0	-0.3015	-0.2174	-0.1682	-0.1333	-0.1062	-0.0841	-0.0654	-0.0492	-0.0349
37	0.1826	19	0.2977	1	0	0.0097	0.0187	0.0271	0.0349	0.0423	0.0492	0.0558	0.0620
38	0.1839	20	0.3029	2	0.0841	0.0891	0.0938	0.0984	0.1028	0.1071	0.1112	0.1152	0.1190
39	0.1852	21	0.3079	3	0.1333	0.1366	0.1399	0.1430	0.1461	0.1491	0.1520	0.1549	0.1577
40	0.1865	22	0.3126	4	0.1682	0.1707	0.1732	0.1756	0.1779	0.1802	0.1825	0.1847	0.1869
41	0.1878	23	0.3170	5	0.1953	0.1973	0.1993	0.2012	0.2031	0.2050	0.2069	0.2087	0.2105
42	0.1890	24	0.3214	6	0.2174	0.2191	0.2207	0.2224	0.2240	0.2256	0.2271	0.2287	0.2302
43	0.1902	25	0.3255	7	0.2361	0.2376	0.2390	0.2404	0.2418	0.2431	0.2445	0.2458	0.2472
44	0.1913	26	0.3294	8	0.2523								
45	0.1925	27	0.3333	9	0.2666								
46	0.1936	28	0.3369	10	0.2794								
47	0.1947	29	0.3405	11	0.2910								
48	0.1957	30	0.3439	12	0.3015								
49	0.1968	31	0.3472	13	0.3112								
		32	0.3504	14	0.3202								
		33	0.3536	15	0.3286								
		34	0.3566	16	0.3364								
		35	0.3595	17	0.3438								
		36	0.3624	18	0.3507								
		37	0.3651	19	0.3573								
		38	0.3678	20	0.3635								
		39	0.3704	21	0.3694								
		40	0.3730	22	0.3751								
		41	0.3755	23	0.3805								
		42	0.3779	24	0.3856								
		43	0.3803	25	0.3906								
		44	0.3826	26	0.3953								
		45	0.3849	27	0.3999								
		46	0.3871	28	0.4043								
		47	0.3893	29	0.4086								
		48	0.3914	30	0.4127								
		49	0.3935	31	0.4167								
				32	0.4205								
				33	0.4243								
				34	0.4279								
				35	0.4314								
				36	0.4348								
				37	0.4382								
				38	0.4414								
				39	0.4445								
				40	0.4476								
				41	0.4506								
				42	0.4535								
				43	0.4564								
				44	0.4592								
				45	0.4619								
				46	0.4646								
				47	0.4672								
				48	0.4697								
				49	0.4722								

x_d at
60 cycles
 $x_d = 0.2794 \log_{10} d$
 $d = \text{separation, feet.}$

TABLE 7—ZERO-SEQUENCE RESISTANCE AND INDUCTIVE REACTANCE FACTORS (r_o, x_o)* Ohms per Conductor per Mile

	ρ Meter Ohm	FREQUENCY		
		25 Cycles	50 Cycles	60 Cycles
r_o	All	0.1192	0.2383	0.2880
	1	0.921	1.736	2.050
x_o	5	1.043	1.980	2.343
	10	1.095	2.085	2.469
	50	1.217	2.329	2.762
	100†	1.270	2.434	2.888
	500	1.392	2.679	3.181
	1000	1.444	2.784	3.307
	5000	1.566	3.028	3.600
	10 000	1.619	3.133	3.726

*From Formulas:
 $r_o = 0.004764f$

$$x_o = 0.006985f \log_{10} 4.665 600 \rho^2$$

where $f = \text{frequency}$
 $\rho = \text{Resistivity (meter-ohm)}$

†This is an average value which may be used in the absence of definite information.

TABLE 8—SHUNT CAPACITIVE REACTANCE SPACING FACTOR (x_d') MEGOHMS PER CONDUCTOR PER MILE

25 CYCLES

		SEPARATION											
		INCHES											
Feet		0	1	2	3	4	5	6	7	8	9	10	11
0	—	0	0	0	0	0	0	0	0	0	0	0	0
1	0	-0.1769	-0.1276	-0.0987	-0.0782	-0.0623	-0.0494	-0.0384	-0.0289	-0.0205	-0.0130	-0.0062	0.0463
2	0.0494	0.0523	0.0551	0.0577	0.0603	0.0628	0.0652	0.0676	0.0698	0.0720	0.0742	0.0762	0.0782
3	0.0782	0.0802	0.0821	0.0839	0.0857	0.0875	0.0892	0.0909	0.0925	0.0941	0.0957	0.0972	0.0987
4	0.0987	0.1002	0.1016	0.1030	0.1044	0.1058	0.1071	0.1084	0.1097	0.1109	0.1122	0.1134	0.1146
5	0.1146	0.1158	0.1169	0.1181	0.1192	0.1203	0.1214	0.1225	0.1235	0.1246	0.1256	0.1266	0.1276
6	0.1276	0.1286	0.1295	0.1305	0.1314	0.1324	0.1333	0.1342	0.1351	0.1360	0.1368	0.1377	0.1386
7	0.1386	0.1394	0.1402	0.1411	0.1419	0.1427	0.1435	0.1443	0.1450	0.1458	0.1466	0.1473	0.1481
8	0.1481												
9	0.1565												
10	0.1640												
11	0.1707												
12	0.1769												
13	0.1826												
14	0.1879												
15	0.1928												
16	0.1974												
17	0.2017												
18	0.2058												
19	0.2097												
20	0.2133												
21	0.2168												
22	0.2201												
23	0.2233												
24	0.2263												
25	0.2292												
26	0.2320												
27	0.2347												
28	0.2373												
29	0.2398												
30	0.2422												
31	0.2445												
32	0.2468												
33	0.2490												
34	0.2511												
35	0.2532												
36	0.2552												
37	0.2571												
38	0.2590												
39	0.2609												
40	0.2627												
41	0.2644												
42	0.2661												
43	0.2678												
44	0.2695												
45	0.2711												
46	0.2726												
47	0.2742												
48	0.2756												
49	0.2771												

x_d' at
25 cycles
 $x_d' = .1640 \log_{10} d$
 d =separation, feet.

FUNDAMENTAL
EQUATIONS

$$x_i' = x_2' = x_a' + x_d'$$

$$x_o' = x_a' + x_e' - 2x_d'$$

50 CYCLES

		SEPARATION											
		INCHES											
Feet		0	1	2	3	4	5	6	7	8	9	10	11
0	—	0	0	0	0	0	0	0	0	0	0	0	0
1	0	-0.0885	-0.0638	-0.0494	-0.0391	-0.0312	-0.0247	-0.0192	-0.0144	-0.0102	-0.0065	-0.0031	0.0232
2	0.0247	0.0261	0.0275	0.0289	0.0302	0.0314	0.0326	0.0338	0.0349	0.0360	0.0371	0.0381	0.0386
3	0.0391	0.0401	0.0410	0.0420	0.0429	0.0437	0.0446	0.0454	0.0463	0.0471	0.0478	0.0486	0.0492
4	0.0494	0.0501	0.0508	0.0515	0.0522	0.0529	0.0535	0.0542	0.0548	0.0555	0.0561	0.0567	0.0572
5	0.0573	0.0579	0.0585	0.0590	0.0596	0.0601	0.0607	0.0612	0.0618	0.0623	0.0628	0.0633	0.0638
6	0.0638	0.0643	0.0648	0.0652	0.0657	0.0662	0.0666	0.0671	0.0675	0.0680	0.0684	0.0689	0.0693
7	0.0693	0.0697	0.0701	0.0705	0.0709	0.0713	0.0717	0.0721	0.0725	0.0729	0.0733	0.0737	0.0740
8	0.0740												
9	0.0782												
10	0.0820												
11	0.0854												
12	0.0885												
13	0.0913												
14	0.0940												
15	0.0964												
16	0.0987												
17	0.1009												
18	0.1029												
19	0.1048												
20	0.1067												
21	0.1084												
22	0.1100												
23	0.1116												
24	0.1131												
25	0.1146												
26	0.1160												
27	0.1173												
28	0.1186												
29	0.1199												
30	0.1211												
31	0.1223												
32	0.1234												
33	0.1245												
34	0.1255												
35	0.1266												
36	0.1276												
37	0.1286												
38	0.1295												
39	0.1304												
40	0.1313												
41	0.1322												
42	0.1331												
43	0.1339												
44	0.1347												
45	0.1355												
46	0.1363												
47	0.1371												
48	0.1378												
49	0.1386												

x_d' at
50 cycles
 $x_d' = 0.08198 \log_{10} d$
 d =separation, feet.

x_d' at
60 cycles
 $x_d' = 0.06831 \log_{10} d$
 d =separation, feet.

TABLE 9—ZERO-SEQUENCE SHUNT CAPACITIVE REACTANCE FACTOR x_o' MEGOHMS PER CONDUCTOR PER MILE

Conductor Height Above Ground Feet	FREQUENCY		
	25 Cycles	50 Cycles	60 Cycles
10	0.640	0.320	0.267
15	0.727	0.363	0.303
20	0.788	0.394	0.328
25	0.836	0.418	0.348
30	0.875	0.437	0.364
40	0.936	0.468	0.390
50	0.984	0.492	0.410
60	1.023	0.511	0.426
70	1.056	0.528	0.440
80	1.084	0.542	0.452
90	1.109	0.555	0.462
100	1.132	0.566	0.472

$$x_o' = \frac{12.30}{f} \log_{10} 2 h$$

where h =height above ground.
 f =frequency.

IV CORONA

With the increased use of high-voltage transmission lines and the probability of going to still higher operating voltages, the common aspects of corona (radio influence and corona loss) have become more important in the design of transmission lines.

In the early days of high-voltage transmission, corona was something which had to be avoided, largely because of the energy loss associated with it. In recent years the RI (radio influence) aspect of corona has become more important. In areas where RI must be considered, this factor might establish the limit of acceptable corona performance.

Under conditions where abnormally high voltages are present, corona can affect system behavior. It can reduce the overvoltage on long open-circuited lines. It will attenuate lightning voltage surges (see Sec. 29 Chap. 15) and switching surges.¹⁷ By increasing the electrostatic coupling between the shield wire and phase conductors, corona at times of lightning strokes to towers or shield wires reduces the voltage across the supporting string of insulators and thus, in turn, reduces the probability of flash-over and improves system performance. On high-voltage lines grounded through a ground-fault neutralizer, the in-phase current due to corona loss can prevent extinction of the arc during a line to ground fault.²⁸

6. Factors Affecting Corona

At a given voltage, corona is determined by conductor diameter, line configuration, type of conductor, condition of its surface, and weather. Rain is by far the most important aspect of weather in increasing corona. Hoarfrost and fog have resulted in high values of corona loss on experimental test lines. However, it is believed that these high losses were caused by sublimation or condensation of water vapor, which are conditions not likely to occur on an operating line because the conductor temperature would normally be above ambient. For this reason, measurements of loss made under conditions of fog and hoarfrost might be unreliable unless the conductors were at operating temperatures. Falling snow generally causes only a moderate increase in corona. Also, relative humidity, temperature, atmospheric pressure, and the earth's electric field can affect corona, but their effect is minor compared to that of rain. There are apparently other unknown factors found under desert conditions which can increase corona.¹⁹

The effect of atmospheric pressure and temperature is generally considered to modify the critical disruptive voltage of a conductor directly, or as the $\frac{2}{3}$ power of the air density factor, δ , which is given by:

$$\delta = \frac{17.9b}{459 + ^\circ F} \quad (78)$$

where

b = barometric pressure in inches of mercury
 $^\circ F$ = temperature in degrees Fahrenheit.

The temperature to be used in the above equation is generally considered to be the conductor temperature. Under

TABLE 10—STANDARD BAROMETRIC PRESSURE AS A FUNCTION OF ALTITUDE

Altitude, feet	Pressure, in. Hg.	Altitude, feet	Pressure, in. Hg.
-1000	31.02	4 000	25.84
- 500	30.47	5 000	24.89
		6 000	23.98
0	29.92	8 000	22.22
1000	28.86	10 000	20.58
2000	27.82	15 000	16.88
3000	26.81	20 000	13.75

standard conditions (29.92 in. of Hg. and 77°F) the air density factor equals 1.00. The air density factor should be considered in the design of transmission lines to be built in areas of high altitude or extreme temperatures. Table 10 gives barometric pressures as a function of altitude.

Corona in fair weather is negligible or moderate up to a voltage near the disruptive voltage for a particular conductor. Above this voltage corona effects increase very rapidly. The calculated disruptive voltage is an indicator of corona performance. A high value of critical disruptive voltage is not the only criterion of satisfactory corona performance. Consideration should also be given to the sensitivity of the conductor to foul weather. Corona increases somewhat more rapidly on smooth conductors than it does on stranded conductors. Thus the relative corona characteristics of these two types of conductors might interchange between fair and foul weather. The equation for critical disruptive voltage is:

$$E_c = g_0 \delta^{2/3} r m \log_e D/r \quad (79a)$$

where:

E_c = critical disruptive voltage in kv to neutral

g_0 = critical gradient in kv per centimeter. (Ref. 10 and 16 use $g_0 = 21.1$ Kv/cm rms. Recent work indicates value given in Sec. 10 is more accurate.)

r = radius of conductor in centimeters

D = the distance in centimeters between conductors, for single-phase, or the equivalent phase spacing, for three-phase voltages.

m = surface factor (common values, 0.84 for stranded, 0.92 for segmental conductors)

δ = air density factor

The more closely the surface of a conductor approaches a smooth cylinder, the higher the critical disruptive voltage assuming constant diameter. For equal diameters, a stranded conductor is usually satisfactory for 80 to 85 percent of the voltage of a smooth conductor. Any distortion of the surface of a conductor such as raised strands, die burrs, and scratches will increase corona. Care in handling conductors should be exercised, and imperfections in the surface should be corrected, if it is desired to obtain the best corona performance from a conductor. Die burrs and die grease on a new conductor, particularly the segmental type, can appreciably increase corona effects when it is first placed in service. This condition improves with time, taking some six months to become stable.

Strigel⁴⁴ concluded that the material from which a conductor is made has no effect on its corona performance. In

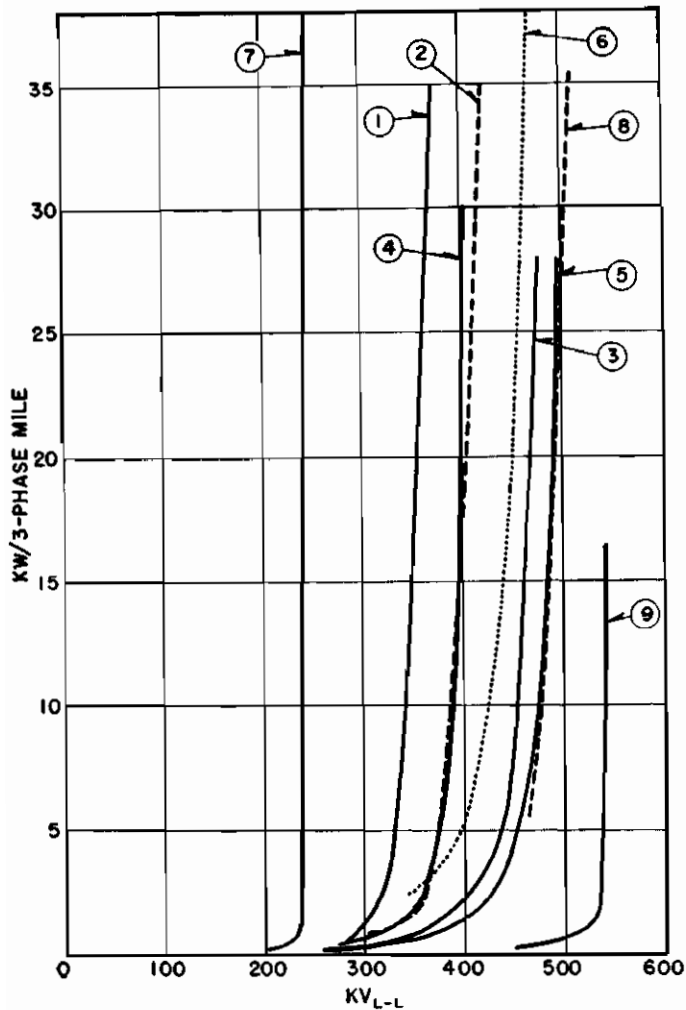

Curve 1—1.4 in. HH copper. $\delta=0.88$. Ref. 19. Corona loss test made in desert at a location where abnormally high corona loss is observed on the Hoover-Los Angeles 287.5-kv line, which is strung with this conductor. Measurement made in three-phase test line. This particular curve is plotted for $\delta=0.88$ to show operating condition in desert. All other curves are for $\delta=1.00$.

Curve 2—Same as curve 1, except converted to $\delta=1.00$.

Curve 3—1.4 in. HH copper. Ref. 12. Corona loss test made in California. Comparison with curve 2 shows effect of desert conditions. Measurements made on three-phase test line, 30-foot flat spacing, 16-foot sag, 30-foot ground clearance, 700 feet long.

Curve 4—1.1 in. HH. Ref. 13. Measurements made on three-phase test line, 22-foot flat spacing, 16-foot sag, 30-foot clearance to ground, 700 feet long.

Curve 5—1.65 in. smooth. Ref. 12. This conductor had a poor surface. Measurements made on three-phase test line, 30-foot spacing, 16-foot sag, 30-foot ground clearance, 700 feet long.

Curve 6—1.65 in. smooth aluminum. Ref. 27. Reference curve obtained by converting per-phase measurement to loss on three-phase line. Dimensions of line not given.

Curve 7—1.04 in. smooth cylinder. Ref. 23. In reference this conductor is referred to as having an infinite number of strands. Plotted curve obtained by conversion of per-phase measurements to three-phase values, using an estimated value for charging kva, to give loss on a line having 45-foot flat configuration.

Curve 8—1.96 in. smooth aluminum. Ref. 28. Reference curve gives three-phase loss, but line dimensions are not given.

Curve 9—1.57 in. smooth. Ref. 23. This conductor was smooth and clean. Reference curve gives per-phase values. Plotted curve is for 45-foot flat spacing.

Fig. 27—Fair-Weather Corona-Loss Curves for Smooth Conductors; Air Density Factor, $\delta=1$.

industrial areas, foreign material deposited on the conductor can, in some cases, seriously reduce the corona performance. (Reference 28 gives some measurements made in an industrial area.)

Corona is an extremely variable phenomenon. On a conductor energized at a voltage slightly above its fair weather corona-starting voltage, variations up to 10 to 1 in corona loss and radio-influence factor have been recorded during fair weather. The presence of rain produces corona loss on a conductor at voltages as low as 65 percent of the voltage at which the same loss is observed during fair-weather. Thus it is not practical to design a high-voltage line such that it will never be in corona. This also precludes expressing a ratio between fair- and foul-weather corona, since the former might be negligibly small.

If a conductor is de-energized for more than about a day, corona is temporarily increased. This effect is moderate compared to that of rain. It can be mitigated by re-energizing a line during fair weather where such a choice is possible.

7. Corona Loss

Extensive work by a large number of investigators has been done in determining corona loss on conductors operated at various voltages. This work has led to the devel-

opment of three formulas^(10,14,16) generally used in this country (Reference 18 gives a large number of formulas). The Carroll-Rockwell and the Peterson formulas are considered the most accurate especially in the important low loss region (below 5 kw per three-phase mile). The Peterson formula, when judiciously used, has proved to be a reliable indicator of corona performance (see Sec. 9) for transmission voltages in use up to this time. Recent work on corona loss has been directed toward the extra-high-voltage range and indicates that more recent information should be used for these voltages.

Fair-weather corona-loss measurements made by a number of different investigators are shown in Figs. 27, 28, and 29. All curves are plotted in terms of kilowatts per three-phase mile. The data presented in these curves has been corrected for air density factor, δ , by multiplying the test voltage by $1/\delta^{2/3}$. Some error might have been introduced in these curves because in most cases it was necessary to convert the original data from per-phase measurements. The conversions were made on the basis of voltage gradient at the surface of each conductor. The curves should be used as an indicator of expected performance during fair weather. For a particular design, reference should be made to the original publications, and a conversion made for the design under consideration. The relation between fair-

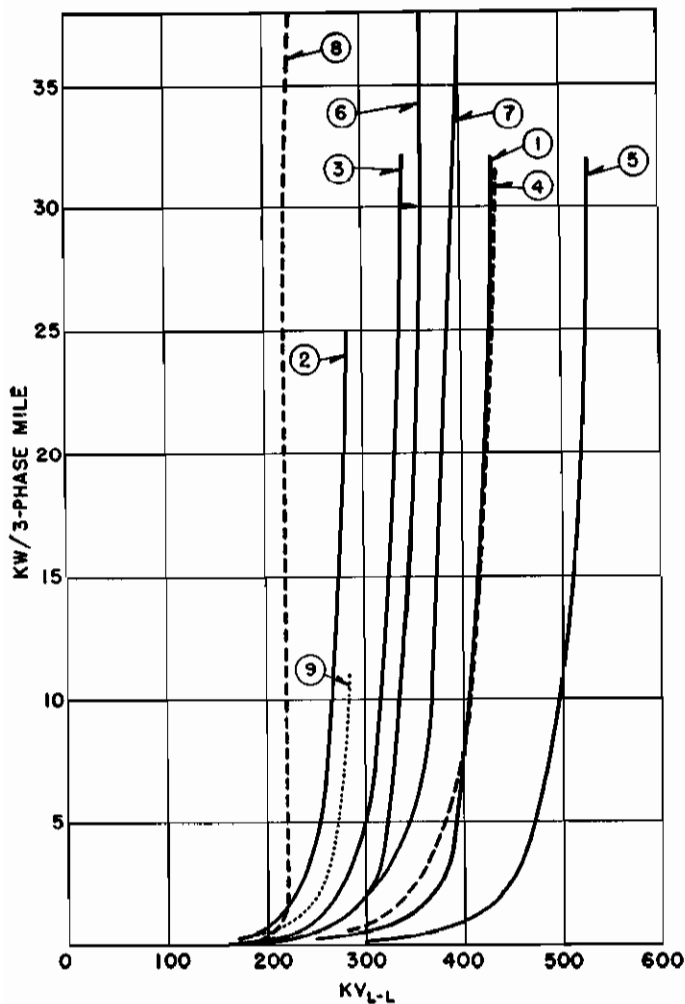

- Curve 1—1.4 in. ACSR. Ref. 12. Conductor was washed with gasoline then soap and water. Test configuration: three-phase line, 30-foot flat spacing, 16-foot sag, 30-foot ground clearance, 700 feet long.
- Curve 2—1.0 in. ACSR. Ref. 11. Conductor weathered by exposure to air without continuous energization. Test configuration: three-phase line, 20-foot flat spacing, 700 feet long.
- Curve 3—1.125 in. hollow copper. Ref. 14. Washed in same manner as for curve 1. Test configuration: three-phase line, 22-foot flat spacing.
- Curve 4—1.49 in. hollow copper. Ref. 14. Washed in same manner as for curve 1. Test configuration: three-phase line, 30-foot flat spacing, 16-foot sag, 30-foot ground clearance, 700 feet long.
- Curve 5—2.00 in. hollow aluminum. Ref. 14. Washed in same manner as for curve 1. Test configuration: three-phase line, 30-foot flat spacing, 16-foot sag, 30-foot ground clearance, 700 feet long.
- Curve 6—1.09 in. steel-aluminum. Ref. 22. Reference curve is average fair-weather corona loss obtained by converting per-phase measurements to three-phase values, for a line 22.9 foot flat spacing, 32.8 feet high. This conductor used on 220-kv lines in Sweden which have above dimensions.
- Curve 7—1.25 in. steel-aluminum. Ref. 22 App. A. Plotted curve obtained by estimating average of a number of fair-weather per-phase curves given in reference and converting to three-phase loss for line having 32-foot flat spacing, 50-foot average height.
- Curve 8—1.04 in. steel-aluminum, 24-strand. Ref. 23. Plotted curve obtained by conversion of per-phase measurements to three-phase values, using an estimated value for charging kva, to give loss on a line having 45-foot flat configuration.
- Curve 9—0.91 in. Hollow Copper. Ref. 11. Conductor washed. Test configuration: three-phase line, 20-foot flat spacing, 700 feet long.

Fig. 28—Fair-Weather Corona-Loss Curves for Stranded Conductors; Air Density Factor, $\delta = 1$.

and foul-weather corona loss and the variation which can be expected during fair weather is shown in Fig. 30 for one conductor.

Corona loss on a satisfactory line is primarily caused by rain. This is shown by the fairly high degree of correlation between total rainfall and integrated corona loss which has been noted.^(21,26,41) The corona loss at certain points on a transmission line can reach high values during bad storm conditions. However, such conditions are not likely to occur simultaneously all along a line. Borgquist and Vrethem expect only a variation from 1.6 to 16 kw per mile, with an average value of 6.5 kw per mile, on their 380-kv lines now under construction in Sweden. The measured loss on their experimental line varied from 1.6 to 81 kw per mile. The calculated fair-weather corona loss common in the U.S.A. is generally less than one kw per mile, based on calculations using Reference 16. Where radio-influence must be considered, the annual corona loss will not be of much economic importance²⁰, and the maximum loss will not constitute a serious load.

Corona loss is characterized on linear coordinates by a rather gradual increase in loss with increased voltage up to the so-called "knee" and above this voltage, a very rapid increase in loss. The knee of the fair-weather loss curve is generally near the critical disruptive voltage. A transmis-

sion line should be operated at a voltage well below the voltage at which the loss begins to increase rapidly under fair-weather conditions. Operation at or above this point can result in uneconomical corona loss. A very careful analysis, weighing the annual energy cost and possibly the maximum demand against reduced capitalized line cost, must be made if operation at a voltage near or above the knee of the fair-weather loss curve is contemplated.

Corona loss on a conductor is a function of the voltage gradient at its surface. Thus the effect of reduced conductor spacing and lowered height is to increase the corona loss as a function of the increased gradient. On transmission lines using a flat conductor configuration, the gradient at the surface of the middle phase conductor is higher than on the outer conductor. This results in corona being more prevalent on the middle conductor.

8. Radio Influence (RI)

Radio influence is probably the factor limiting the choice of a satisfactory conductor for a given voltage. The RI performance of transmission lines has not been as thoroughly investigated as corona loss. Recent publications (see references) present most of the information available. RI plotted against voltage on linear graph paper is characterized by a gradual increase in RI up to a vol-

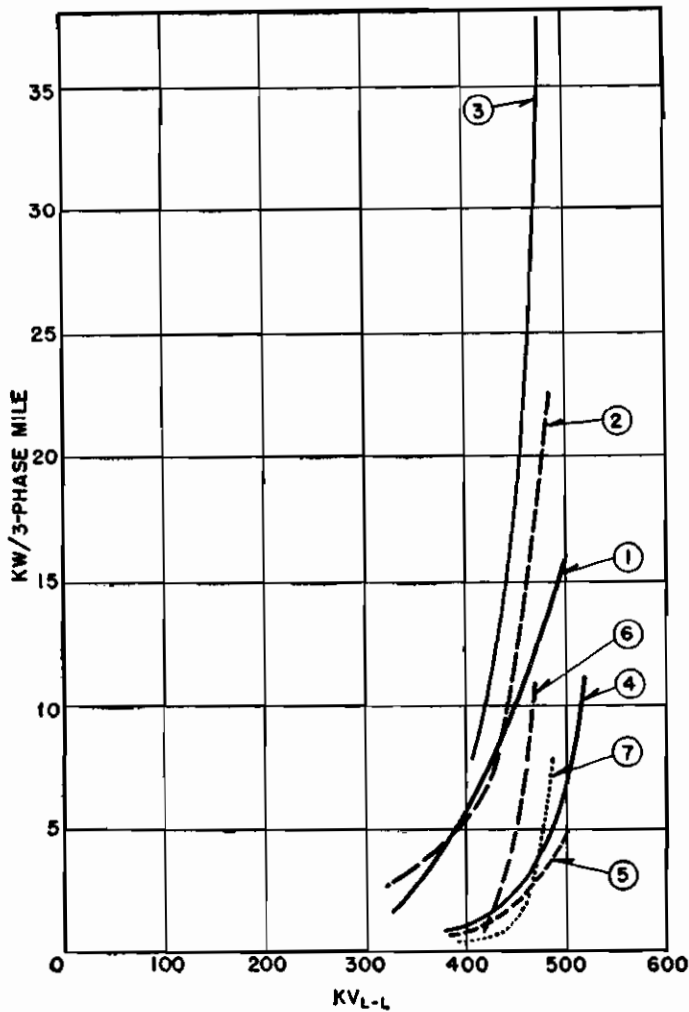

Fig. 29—Fair-Weather Corona-Loss Curves for Two-, Three-, and Four-conductor Bundles; Air Density Factor, $\delta = 1.00$.

tage slightly below the minimum voltage at which measurable corona loss is detected. Above this voltage, the increase in the RI is very rapid. The rate of increase in RI is influenced by conductor surface and diameter, being higher for smooth conductors and large-diameter conductors. Above a certain voltage, the magnitude of the RI field begins to level off. For practical conductors, the leveling off value is *much* too high to be acceptable, and where RI is a factor, lines must be designed to operate below the voltage at which the rapid increase starts during fair weather. Figures 32 and 33 are characteristic RI curves. The relation between fair- and foul-weather corona performance is shown in Fig. 32.

An evaluation of RI in the design of a high-voltage line must consider not only its magnitude, but its effect on the various communication services which require protection. Amplitude-modulated broadcasting and power-line carrier are the most common services encountered but other services such as aviation, marine, ship-to-shore SOS calls, police and a number of government services might also have to be considered.

In determining the RI performance of a proposed line, the magnitude of the RI factors for the entire frequency

Curve 1—4/0.985/15.7* (Smooth) Ref. 25. δ not given, but assumed 1.10, which is average value for Germany. Reference curve obtained by converting single-phase measurements to three-phase values on the basis of surface gradient. Dimensions of line used in making conversion are not given.

Curve 2—4/0.827/15.7* (stranded aluminum-steel). Ref. 25. $\delta = 1.092$. See discussion of Curve 1.

Curve 3—3/0.985/11.8* (Smooth). Ref. 26. $\delta = 1.092$. Reference curve gives single-phase measurements versus line-to-ground voltage, but it is not clear whether actual test voltage or equivalent voltage at line height is given. Latter was used in making the conversion to three-phase. If this is wrong, curve is approximately 15 percent low in voltage. Converted to flat configuration of 45 feet.

Curve 4—2/1.09/17.7* (Stranded aluminum-steel). $\delta = 1.01$. Ref. 12, App. A. Reference curve gives per-phase measurements versus gradient. Converted to three-phase corona loss on line of 42.5-foot average height, 39.4-foot flat configuration.

Curve 5—2/1.25/17.7* (Stranded aluminum-steel) δ not given, probably close to unity. Ref. 12. Reference curve, which gives three-phase corona loss, was converted from per-phase measurements. Dimensions 42.5 feet average height, 39.4 feet flat configuration. This conductor was selected for use on the Swedish 380-kv system. Original author probably selected a worse fair-weather condition than the writer did in plotting curve 4, which could account for their closeness.

Curve 6—2/1.04/23.7* (Stranded aluminum-steel). δ not given. Ref. 13. Plotted curve is average of two single-phase fair-weather curves, converted to three-phase loss for 45-foot flat configuration. See Curve 7.

Curve 7—2/1.04/15.7* (Stranded aluminum-steel). δ not given. Ref. 13. Plotted curve is average of two single-phase fair-weather curves, converted to three-phase loss for 45-foot flat configuration. Data for curves 6 and 7 were taken at same time in order to show effect of sub-conductor separation.

*Bundle-conductor designation—number of sub-conductors/outside diameter of each sub-conductor in inches/separation between adjacent sub-conductors in inches.

range of communication services likely to be encountered, should be known. An evaluation of these factors in terms of their effect on various communication services must take into consideration many things. These are available signal intensities along the line, satisfactory signal-to-noise ratios, effect of weather on the RI factors and on the importance of particular communication services, number and type of receivers in vicinity of the line, proximity of particular receivers, transfer of RI to lower-voltage circuits, the general importance of particular communication services, and means for improvement of reception at individual receiver locations.²¹ For extra-high-voltage and double-circuit high-voltage lines the tolerable limits of RI might be higher because the number of receivers affected, the coupling to lower voltage circuits, and the coupling to receiver antennas is reduced. Also fewer lines are required for the same power handling ability, and wider right-of-ways are used which tend to reduce the RI problem.

Although RI increases very rapidly with increased gradient at the surface of a conductor, theoretical considerations of the radiation characteristics of a transmission line as spacing is reduced, indicate that the RI from a transmission line will not be seriously affected by reduced spacing.⁴²

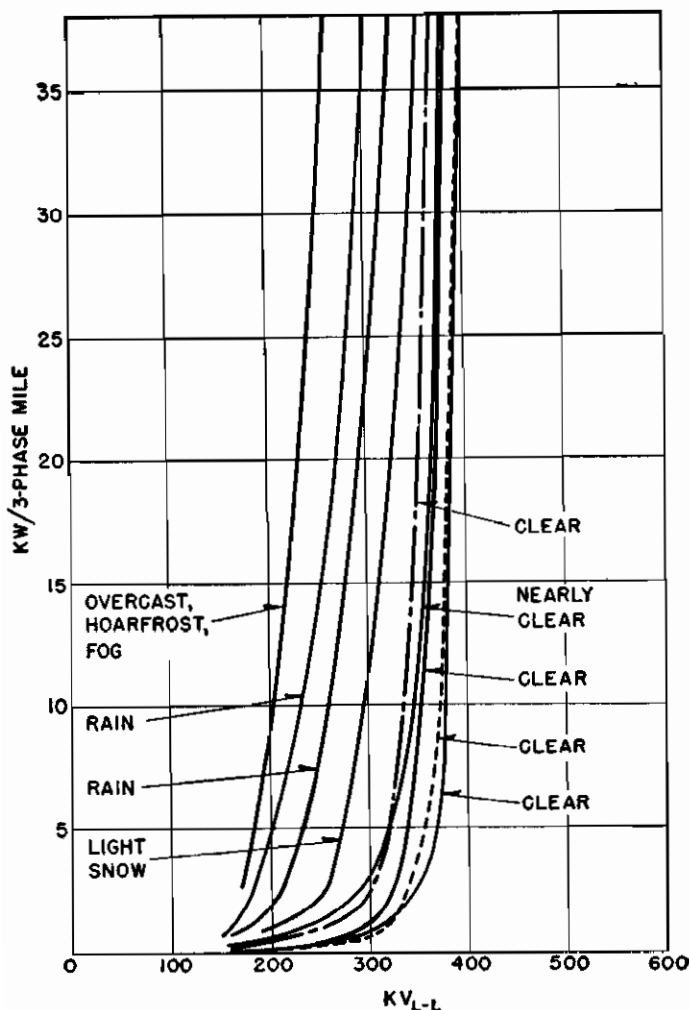

Fig. 30—Corona Loss on 1.09 Inch Stranded Aluminum-Steel Conductor under Different Weather Conditions. This conductor is in use on the Swedish 220-kv system. Note variation in fair-weather corona loss and the relation between fair- and foul-weather corona loss. Plotted curves obtained by converting per-phase measurements to three-phase values for a line having 32-foot flat spacing, 50-foot average height. No correction made for air density factor. Ref. 22, App. A.

The conductor configuration, the number of circuits, and the presence of ground wires affect the radiation from the line with a given RI voltage on the conductors. Very little is known about the radiation characteristics of transmission lines and caution should be exercised in applying data not taken on a line configuration closely approximating the design under consideration.

The RI field from a transmission line varies somewhat as the inverse of the radio frequency measured. Thus services in the higher-frequency bands, (television³⁷, frequency-modulated broadcasting, microwave relay, radar, etc.) are less apt to be affected. Directional antennas which are generally used at these frequencies, on the average, increase the signal-to-noise ratio. The lower signal strengths, and wider band-widths generally found in the high-frequency bands can alter this picture somewhat. Frequency-modulated broadcast is inherently less sensitive to RI because of its type of modulation.

Standard radio-noise meters^{35,36} can measure the average, quasi-peak, and peak values of the RI field. The average value is the amplitude of the RI field averaged continuously over $\frac{1}{2}$ second. For quasi-peak measurements, a circuit having a short time constant (0.001–0.01 sec.) for charging and a long time constant (0.3 to 0.6 sec.) for discharging is used, with the result that the meter indication is near the peak value of the RI field. Aural tests of radio reception indicate that quasi-peak readings interpreted in terms of broadcast-station field strengths represent more accurately the “nuisance” value of the RI field. The peak value is the maximum instantaneous value during a given period. The type of measurements made must be known before evaluating published RI information or misleading conclusions can be drawn.

The lateral attenuation of RI from a transmission line depends on the line dimensions and is independent of voltage. At distances between 40 and 150 feet from the outer conductor, the attenuation at 1000 kc varies from 0.1 to 0.3 db per foot, with the lower values applying generally to high-voltage lines. Typical lateral attenuation curves are shown in Fig. 34. Lateral attenuation is affected by local conditions. Because of the rapid attenuation of RI laterally from a line, a change of a few hundred feet in the location of a right-of-way can materially aid in protecting a communication service.

9. Selection of Conductor

In the selection of a satisfactory conductor from the standpoint of its corona performance for voltages up to 230 kv, operating experience and current practice are the best guide. Experience in this country indicates that the corona performance of a transmission line will be satisfactory when a line is designed so that the fair-weather corona loss according to Peterson’s formula,¹⁶ is less than one kw per three-phase mile. Unsatisfactory corona performance in areas where RI must be considered has been reported for lines on which the calculated corona loss is in excess of this value, or even less in the case of medium high-voltage lines. Figure 31 is based on Peterson’s formula and indicates satisfactory conductors which can be used on high-voltage lines. For medium high-voltage lines (138 kv) considerably more margin below the one kw curve is necessary because of the increased probability of exposure of receivers to RI from the line, and a design approaching 0.1 kw should be used.

10. Bundle Conductors

A “bundle conductor” is a conductor made up of two or more “sub-conductors”, and is used as one phase conductor. Bundle conductors are also called duplex, triplex, etc., conductors, referring to the number of sub-conductors and are sometimes referred to as grouped or multiple conductors. Considerable work on bundle conductors has been done by the engineers of Siemens-Schuckertwerke²⁷ who concluded that bundle conductors were not economical at 220 kv, but for rated voltages of 400 kv or more, are the best solution for overhead transmission. Rusck and Rathsmann⁴⁶ state that the increase in transmitting capacity justifies economically the use of two-conductor bundles on 220-kv lines.

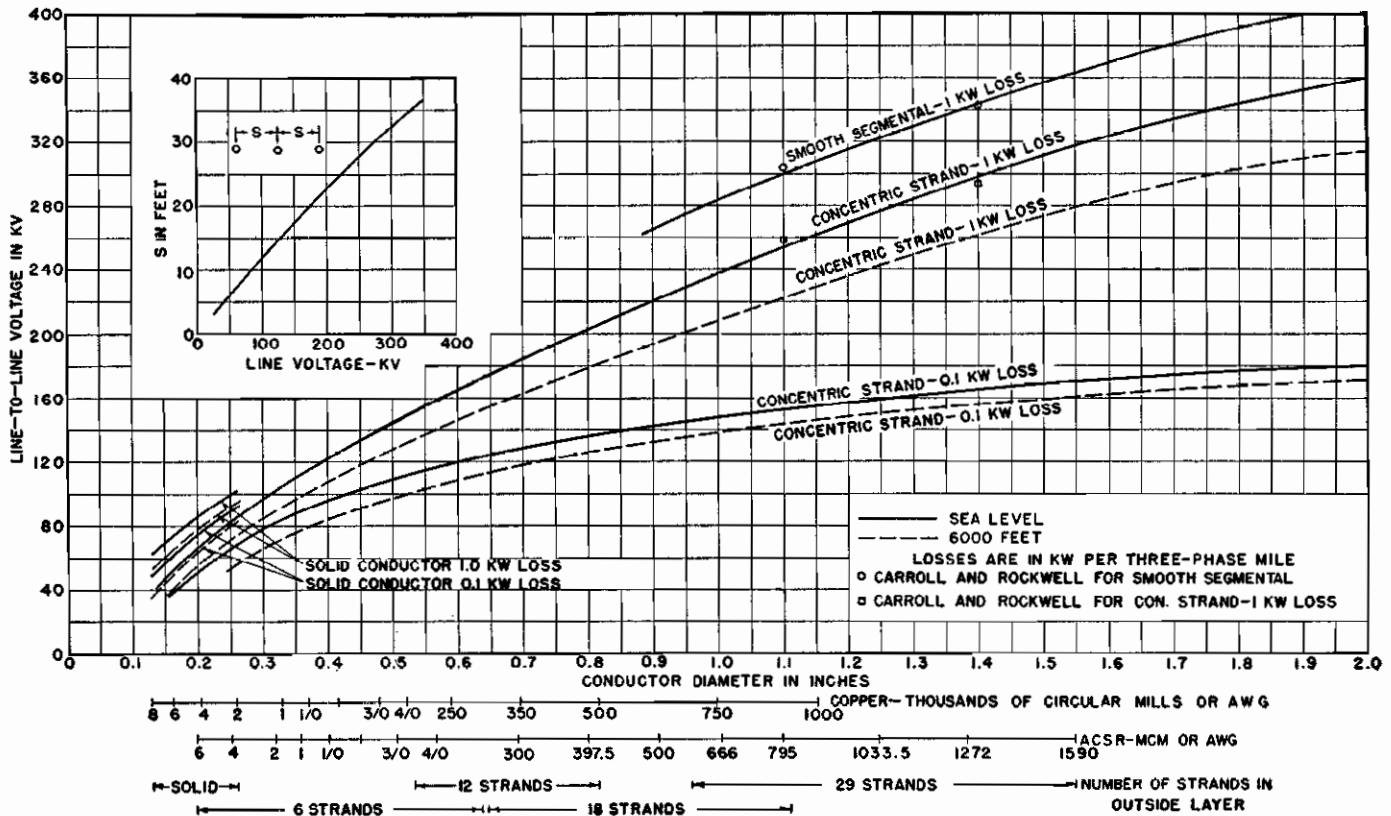

Fig. 31—Quick-Estimating Corona-Loss Curves. Curves based on Peterson's formula with a few check points from the Carrol and Rockwell paper for comparison.

The advantages of bundle conductors are higher disruptive voltage with conductors of reasonable dimensions, reduced surge impedance and consequent higher power capabilities, and less rapid increase of corona loss and RI with increased voltage.^{22,27,28} These advantages must be weighed against increased circuit cost, increased charging kva if it cannot be utilized, and such other considerations as the large amount of power which would be carried by one circuit. It is possible with a two-conductor bundle composed of conductors of practical size to obtain electrical characteristics, excepting corona, equivalent to a single conductor up to eight inches in diameter.

Theoretically there is an optimum sub-conductor separation for bundle conductors that will give minimum crest gradient on the surface of a sub-conductor and hence highest disruptive voltage. For a two-conductor bundle, the separation is not very critical, and it is advantageous to use a larger separation than the optimum which balances the reduced corona performance and slightly increased circuit cost against the advantage of reduced reactance.

Assuming isolated conductors which are far apart compared to their diameter and have a voltage applied between them, the gradient at the surface of one conductor is given by:

$$g = \frac{e}{r \log_e D/r} \quad (79b)$$

where the symbols have the same meaning as used in Eq. (79a). This equation is the same as equation (79a), except that surface factor, m , and air density factor, δ , have been omitted. These factors should be added to Eqs. 80 and 81 for practical calculations. For a two-conductor bundle, the equation for maximum gradient at the surface of a sub-conductor³³ is:

$$g = \frac{e(1+2r/S)}{2r \log_e \frac{D}{\sqrt{rS}}} \quad (80)$$

where:

S = separation between sub-conductors in centimeters.

Because of the effect of the sub-conductors on each other, the gradient at the surface of a sub-conductor is not uniform. It varies in a cosinusoidal manner from a maximum at a point on the outside surface on the line-of-centers, to a minimum at the corresponding point on the inside surface. This effect modifies the corona performance of a bundle conductor such that its corona starting point corresponds to the voltage that would be expected from calculations, but the rate of increase of corona with increased voltage is less than for a single conductor. This effect can be seen by comparing curve 6 of Fig. 28 with curve 2 of Fig. 29. Cahen and Pelissier^{21,24} concluded that the corona performance of a two-conductor bundle is more accurately indicated by the mean between the average

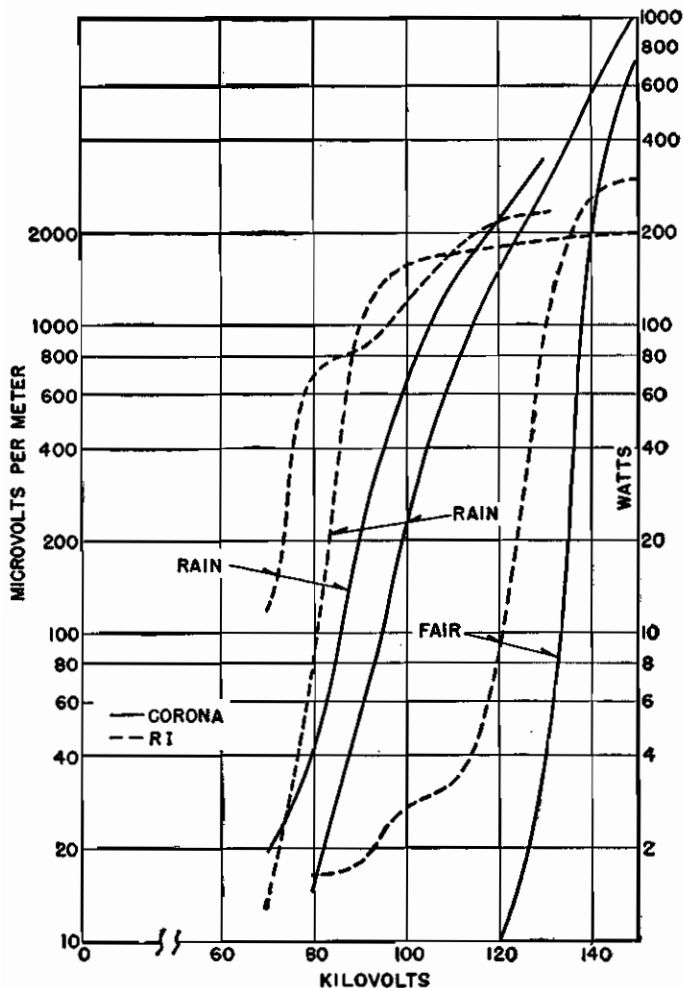

Fig. 32—Radio influence and corona loss measurements made on an experimental test line. Ref. 26.

and maximum gradient at the surface of a sub-conductor, which is given by:

$$g = \frac{e(1+r/S)}{2r \log_{10} \frac{D}{\sqrt{rS}}} \quad (81)$$

If it is desired to determine the approximate disruptive voltage of a conductor, $g_0 = 21.1 \left(1 + \frac{0.301}{\sqrt{r}}\right)$ kv per centimeter rms can be substituted for g and the equations solved for e_0 in kv rms. This value neglects air density Factor and surface factor, which can be as low as 0.80 (consult references 10 and 16 for more accurate calculations).

380 kv Systems using bundle conductors are being built or under consideration in Sweden, France, and Germany.

Curve 1—Average lateral attenuation for a number of transmission lines from 138- to 450-kv. $\circ \times \triangle \square$ are plotted values which apply to this curve only. Test frequency 1000 kc. Ref. 21.

Curve 2—Lateral Attenuation from the 220-kv Eguzon-Chaingy line in France. Line has equilateral spacing, but dimensions not given. Distance measured from middle phase. Test frequency—868 kc. Ref. 24.

Curve 3—Lateral Attenuation from 230-kv Midway—Columbia Line of the Bonneville Power Administration. Conductor height 47.5 feet, test frequency 830 kc. Ref. 42.

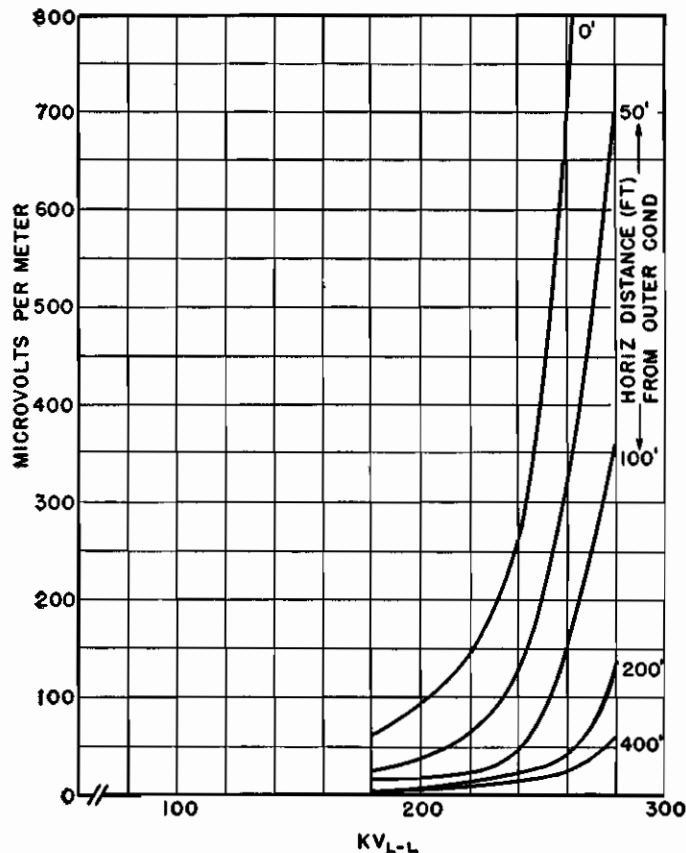

Fig. 33—Fair-Weather Radio-Influence Field from a Transmission Line as a Function of Voltage. Measurements made opposite mid-span on the 230-kv Covington-Grand Coulee Line No. 1 of the Bonneville Power Administration. RI values are quasi-peak. 1.108 inch ACSR conductor, 27-foot flat spacing, 41-foot height, test frequency—800 kc.

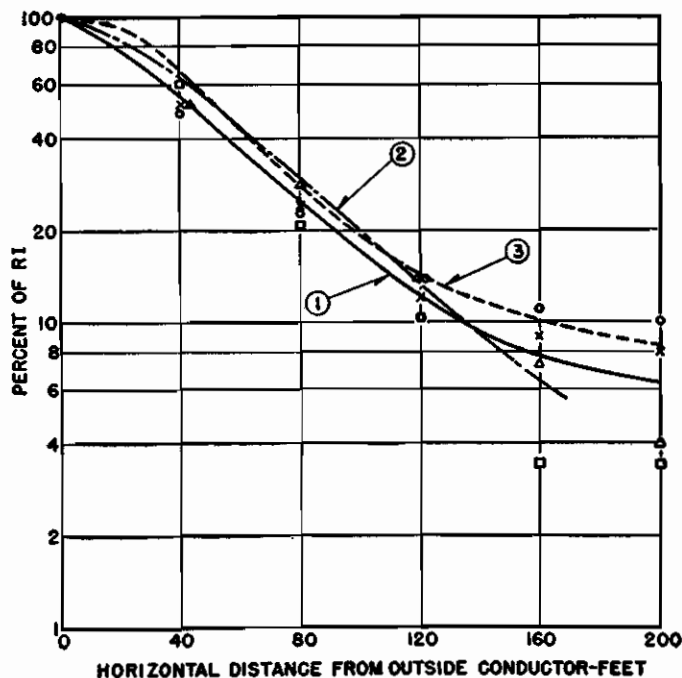

Fig. 34—Lateral Attenuation of Radio Influence in Vicinity of High-Voltage Transmission Lines.

REFERENCES

1. Line Conductors—Tidd 500-kv Test Lines, by E. L. Peterson, D. M. Simmons, L. F. Hickernell, M. E. Noyes. AIEE Paper 47-244.
2. *Symmetrical Components*, (a book), by C. F. Wagner and R. D. Evans. McGraw-Hill Book Company, 1933.
3. Reducing Inductance on Adjacent Transmission Circuits, by H. B. Dwight, *Electrical World*, Jan. 12, 1924, p 89.
4. *Electric Power Transmission* (a book), by L. F. Woodruff. John Wiley and Sons, Inc., 1938.
5. *Electrical Transmission of Power and Signals* (a book), by Edward W. Kimbark. John Wiley and Sons, Inc., 1949.
6. Heating and Current Carrying Capacity of Bare Conductors for Outdoor Service, by O. R. Schurig and C. W. Frick, *General Electric Review* Volume 33, Number 3, March 1930, p 142.
7. Hy-Therm Copper—An Improved Overhead-Line Conductor, by L. F. Hickernell, A. A. Jones, C. J. Snyder. AIEE Paper 49-3.
8. *Electrical Characteristics of Transmission Circuits*, (a book), by W. Nesbit, Westinghouse Technical Night School Press, 1926.
9. Resistance and Reactance of Commercial Steel Conductors, by Prof. H. B. Dwight, *Electric Journal*, January 1919, page 25.
10. Dielectric Phenomena in High-Voltage Engineering (Book) F. W. Peck, Jr. McGraw-Hill Book Co. Inc. New York, 1929.
11. Corona Loss Measurements on a 220-KV 60-Cycle Three-Phase Experimental Line, J. S. Carroll, L. H. Brown, D. P. Dinapoli, *A.I.E.E. Transactions* Vol. 50, 1931, pages 36-43.
12. Corona Losses from Conductors 1.4-inch Diameter, J. S. Carroll, B. Cozzens, T. M. Blakeslee, *A.I.E.E. Transactions* Vol. 53, 1934, pages 1727-33.
13. Corona Losses at 230 KV with One Conductor Grounded, J. S. Carroll, D. M. Simmons, *A.I.E.E. Transactions* Vol. 54, 1935, pages 846-7.
14. Empirical Method of Calculating Corona Loss from High-Voltage Transmission Lines, J. S. Carroll, M. M. Rockwell, *A.I.E.E. Transactions* Vol. 56, 1937, page 558.
15. Corona Loss Measurements for the Design of Transmission Lines to Operate at Voltages between 220-KV and 330-KV. J. S. Carroll, B. Cozzens, *A.I.E.E. Transactions* Vol. 52, 1933, pages 55-62.
16. Development of Corona Loss Formula (discussion of reference 15), W. S. Peterson, *A.I.E.E. Transactions* Vol. 52, pages 62-3.
17. New Techniques on the Anacom—Electric Analog Computer, E. L. Harder, J. T. Carleton, AIEE Technical Paper 50-85.
18. Ein neues Verlustgesetz der Wechselspannungskorona, H. Prinz, Wiss. Veroff. Siemens-Schuckertwerke A.G.—Vol. XIX, July 26, 1940.
19. Desert Measurements of Corona Loss on Conductors for Operation above 230 KV, W. S. Peterson, B. Cozzens, J. S. Carroll, as presented AIEE Convention Pasadena, Calif., June 12-16, 1950.
20. Transmission of Electric Power at Extra High Voltages, Philip Sporn, A. C. Monteith, *A.I.E.E. Transactions*, Vol. 66, 1947 pages 1571-7, disc. 1582.
21. Progress Report on 500-KV Test Project of the American Gas and Electric Company—Corona, Radio Influence, and Other Factors. Philip Sporn, A. C. Monteith, as presented AIEE Convention, Pasadena, Calif. June 12-16, 1950.
22. The Swedish 380-KV System, W. Borgquist, A. Vrethem, see also Appendix, A. B. Henning, S. Skagerlind, CIGRE paper 412, 1948 session, June 24 to July 3, Conference Internationale des Grands Reseaux Electriques a Haute Tension.
23. Influence, sur l'Effet de Couronne, du Diametre et du Profil des Cables des Lignes Aeriennes a Tres Haute Tension, F. Cahen, R. Pelissier, *Revue Generale de l'Electricité*, Vol. 58, pages 279-90.
24. L'emploi de Conducteurs en Faisceaux pour L'Armement des Lignes a Très Haute Tension, F. Cahen, R. Pelissier. *Bull. Soc. Française des Electriciens*, 6th Series, Vol. VIII, No. 79, 1948.
25. Recherches Experimentales sur le Comportement des Conducteurs des Lignes a 400 KV, F. Cahen, R. Pelissier, *Bull. Soc. Française des Electriciens*, 6th Series, Vol. IX No. 99, Dec. 1949.
26. Mecanisme de l'Effet de Couronne sur les Lignes de Transport d'Energie en Courant Alternatif, R. Pelissier, D. Renaudin *Bull. Soc. Française des Electriciens*, 6th Series, Vol. 9, Feb. 1949.
27. Bundelleitungen, W. v. Mangoldt, F. Busemann, A. Buerklin, G. Markt, F. I. Kromer, Siemens-Schuckertwerke, A. G. pamphlet, Berlin-Siemensstadt, 1942.
28. 400-KV Transmission Lines with Special Reference to Multiple Conductor Lines (Bundelleitungen), British Intelligence Objectives Sub-committee, Final Report No. 1833, Item No. 33, S.O. Code—No. 51-8275-33, Technical Information and Documents Unit 40, Cadogan Square, London S.W.1 England.
29. Drehstromfernuebertragung mit Bundelleitern, G. Markt, B. Mengele, *Elektrotechnik und Maschinenbau*, 1932, page 293.
30. Die Wirtschaftliche Bemessung von Bundelleiter-Leitungen *Elektrotechnik und Maschinenbau*, 1935, page 410.
31. 500-KV Experimental Station at Chevilly: Use of Bundle Conductors; Corona Effects; Clearances, P. Ailleret, F. Cahen, Conf. Int. des Grands Res. Electr. a Haute Tension (CIGRE), 1948, paper No. 410.
32. Relative Surface Voltage Gradients of Grouped Conductors, M. Temoshok, *A.I.E.E. Transactions* Vol. 67, Part II, pages 1583-9.
33. Discussion of Reference 32 by C. F. Wagner, *A.I.E.E. Transactions* Vol. 67, Part II, page 1590.
34. Three-Phase Multiple-Conductor Circuits, E. Clarke, *A.I.E.E. Transactions*, Vol. 51, 1932, page 809, Appendix C by S. Crary.
35. Methods of Measuring Radio Noise 1940—A report of the Joint Coordination Committee on Radio Reception of EEI, NEMA, and RMA.
36. Proposed American Standard Specification for a Radio Noise Meter—0.015 to 25 megacycles. Oct. 1949 (Published for one year trial use).
37. Television Interference Seldom Comes from Power Systems, F. L. Greene, *Electrical World*, Jan. 16, 1950, pages 55-9.
38. Effect of Radio Frequencies of a Power System in Radio-Receiving Systems, C. V. Aggers, W. E. Pakala, W. A. Stickel, *A.I.E.E. Transactions*, Vol. 62, 1934, pages 169-72.
39. Measurements Pertaining to the Coordination of Radio Reception with Power Apparatus and Systems, C. M. Foust, C. W. Frick, *A.I.E.E. Transactions* Vol. 62, 1943, pages 284-91, disc. 458.
40. Radio Interference Suppression in Canada, H. O. Merriman, AIEE paper No. 47-140.
41. Results of Tests Carried out at the 500-kv Experimental Station of Chevilly (France), Especially on Corona Behavior of Bundle Conductors, F. Cahen, *A.I.E.E. Transactions*, 1948, Vol. 67, Part II, pages 1118-25.
42. Radio-Noise Influence of 230-KV Lines, H. L. Rorden, *A.I.E.E. Transaction*, Vol. 66, 1947, pages 677-8; disc. 682.
43. Radio Influence from High Voltage Corona, G. R. Slemon, AIEE paper No. 49-60.
44. Comparative Investigation of D.C.- and A.C.-Corona on Two-Conductor Transmission Lines (In German), R. Strigel, *Wissenschaftliche Veroeffentlichungen Aus Den Siemens-Werken*, Vol. 15, Part 2, 1936, pages 68-91.
45. The Swedish 380 KV System, A. Rusck, Bo G. Rathsmann, *Electrical Engineering*, Dec. 1949, pages 1025-9.
46. Series Capacitor and Double Conductors in the Swedish Transmission System, A. Rusck, Bo G. Rathsmann, *Electrical Engineering*, Jan. 1950, pages 53-7.
47. Effect of Earthing on Corona Losses, Conductor Diameter And Length of Insulator Strings, *The Brown Boveri Review*, Vol. XXXV Nos. 7/8, July/August, 1948, pages 192-201.
48. *The Transmission of Electric Power* (a book), by W. A. Lewis, (1948 Lithoprinted Edition) Illinois Institute of Technology.

CHAPTER 4

ELECTRICAL CHARACTERISTICS OF CABLES

Original Author:

H. N. Muller, Jr.

Revised by:

J. S. Williams

CABLES are classified according to their insulation as paper, varnished-cambric, rubber, or asbestos, each of these materials having unique characteristics which render it suitable for particular applications. Because cables for power transmission and distribution are composed of so many different types of insulation, conductors, and sheathing materials, the discussion here must be limited to those cable designs most commonly used. Reasonable estimates of electrical characteristics for cables not listed can be obtained in most cases by reading from the table for a cable having similar physical dimensions.

Paper can be wound onto a conductor in successive layers to achieve a required dielectric strength, and this is the insulation generally used for cables operating at 10 000 volts and higher. Paper insulation is impregnated in different ways, and accordingly cables so insulated can be sub-divided into solid, oil-filled, or gas-filled types.

Solid paper-insulated cables are built up of layers of paper tape wound onto the conductor and impregnated with a viscous oil, over which is applied a tight-fitting, extruded lead sheath. Multi-conductor solid cables are also available, but the material shown here covers only single- and three-conductor types. Three-conductor cables are of either belted or shielded construction. The belted assembly consists of the three separately insulated conductors cabled together and wrapped with another layer of impregnated paper, or belt, before the sheath is applied. In the shielded construction each conductor is individually insulated and covered with a thin metallic non-magnetic shielding tape; the three conductors are then cabled together, wrapped with a metallic binder tape, and sheathed with lead. The purpose of the metallic shielding tape around each insulated conductor is to control the electrostatic stress, reduce corona formation, and decrease the thermal resistance. To minimize circulating current under normal operating conditions and thus limit the power loss, shielding tape only three mils in thickness is used. Solid single-conductor cables are standard for all voltages from 1 to 69 kv; solid three-conductor cables are standard from 1 to 46 kv. Sample sections of paper-insulated single-conductor, three-conductor belted, and three-conductor shielded cables are shown in Fig. 1(a), (b), and (c) respectively.

Oil-filled paper-insulated cables are available in single- or three-conductor designs. Single-conductor oil-filled cable consists of a concentric stranded conductor built around an open helical spring core, which serves as a channel for the flow of low-viscosity oil. This cable is insulated and sheathed in the same manner as solid cables, as a comparison of Figs. 1(a) and 1(d) indicates. Three-conductor oil-filled cables are all of the shielded design, and have three

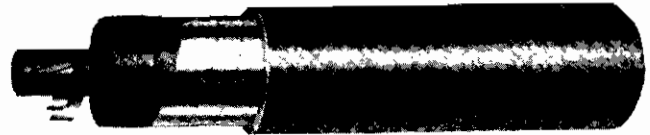

(a) Single-conductor solid, compact-round conductor.

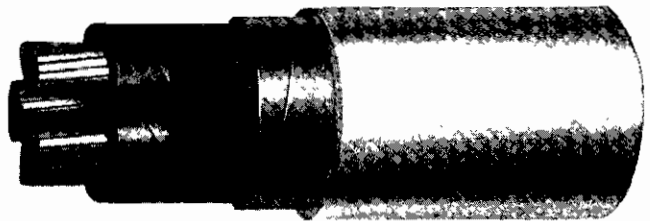

(b) Three-conductor belted, compact-sector conductors.

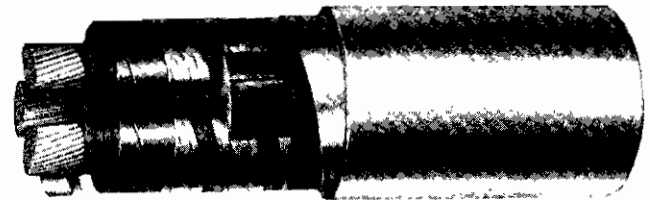

(c) Three-conductor shielded, compact-sector conductors.

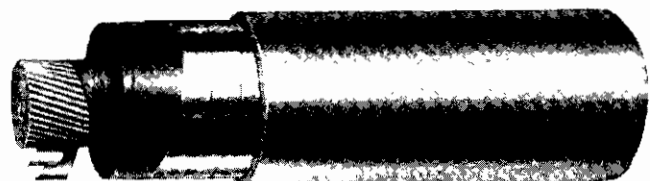

(d) Single-conductor oil-filled, hollow-stranded conductor.

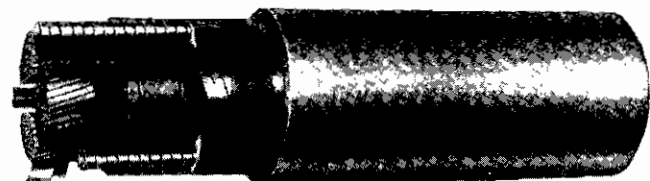

(e) Three-conductor oil-filled, compact-sector conductors.

Fig. 1—Paper-insulated cables.

Courtesy of General Cable Corporation

oil channels composed of helical springs that extend through the cable in spaces normally occupied by filler material. This construction is shown in Fig. 1(e). Oil-filled cables are relatively new and their application has become widespread in a comparatively short time. The oil used is only slightly more viscous than transformer oil, and

remains fluid at all operating temperatures. The oil in the cable and its connected reservoirs is maintained under moderate pressure so that during load cycles oil may flow between the cable and the reservoirs to prevent the development of voids or excessive pressure in the cable. The prevention of void formation in paper insulation permits the use of greatly reduced insulation thickness for a given operating voltage. Another advantage of oil-filled cables is that oil will seep out through any crack or opening which develops in the sheath, thereby preventing the entrance of water at the defective point. This action prevents the occurrence of a fault caused by moisture in the insulation, and since operating records show that this cause accounts for a significant percentage of all high-voltage cable faults, it is indeed a real advantage. Single-conductor oil-filled cables are used for voltages ranging from 69 to 230 kv; the usual range for three-conductor oil-filled cables is from 23 to 69 kv.

Gas-filled cables of the low-pressure type have recently become standard up to 46 kv. The single-conductor type employs construction generally similar to that of solid cables, except that longitudinal flutes or other channels are provided at the inner surface of the sheath to conduct nitrogen along the cable. The three-conductor design employs channels in the filler spaces among the conductors, much like those provided in oil-filled three-conductor cables. The gas is normally maintained between 10 and 15 pounds per square inch gauge pressure, and serves to fill all cable voids and exclude moisture at faulty points in the sheath or joints.

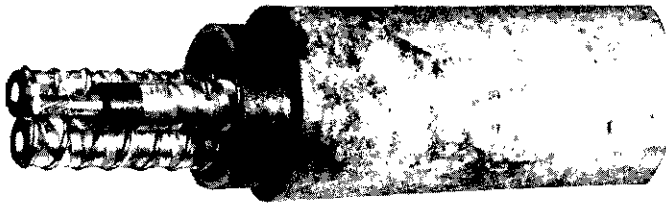

Courtesy of the Okonite-Callender Cable Company

Fig. 2—High-pressure pipe-type oil-filled cable.

High-pressure cables, of either the oil- or gas-filled variety, are being used widely for the higher range of voltages. The physical and electrical characteristics are fairly well known, but their specifications are not yet standardized. The usual application calls for pressure of about 200 pounds per square inch, contained by a steel pipe into which three single-conductor cables are pulled. The immediate presence of the iron pipe makes difficult the calculations of circuit impedance, particularly the zero-sequence quantities. Most high-pressure cables are designed so that the oil or gas filler comes into direct contact with the conductor insulation; in oil-filled pipe-type cables a temporary lead sheath can be stripped from the cable as it is pulled into the steel pipe; in gas-filled pipe-type cables the lead sheath surrounding each conductor remains in place, with nitrogen introduced both inside and outside the sheath so that no differential pressure develops across the sheath. Examples of oil- and gas-filled pipe-type cables are shown in Figs. 2 and 3.

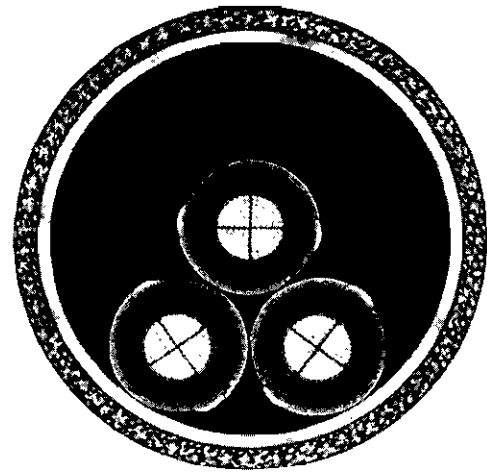

Courtesy of General Cable Corporation

Fig. 3—Cross-section of high-pressure pipe-type gas-filled cable. Oil-filled pipe-type cable may have a similar cross-section.

Compression cable is another high-pressure pipe-type cable in which oil or nitrogen gas at high pressure is introduced within a steel pipe containing lead-sheathed solid-type single-conductor cables; no high-pressure oil or gas is introduced directly inside the lead sheaths, but voids within the solid-type insulation are prevented by pressure exerted externally on the sheaths. This construction is sketched in Fig. 4.

During recent years there has been a trend toward the modification of cable conductors to reduce cost and improve operating characteristics, particularly in multi-conductor cables. Referring to Fig. 5, the first departure from concentric round conductors was the adoption of sector-shaped conductors in three-conductor cables. More recently a crushed stranding that results in a compacted sector has been developed and has found widespread use for conductor sizes of 1/0 A.W.G. and larger. Its use in smaller conductors is not practical. The principal advantages of such a conductor are: reduced overall diameter for a given copper cross-section; elimination of space between the conductor and the insulation, which results in higher

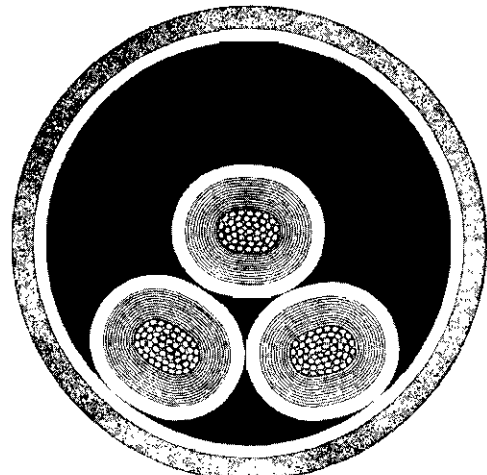
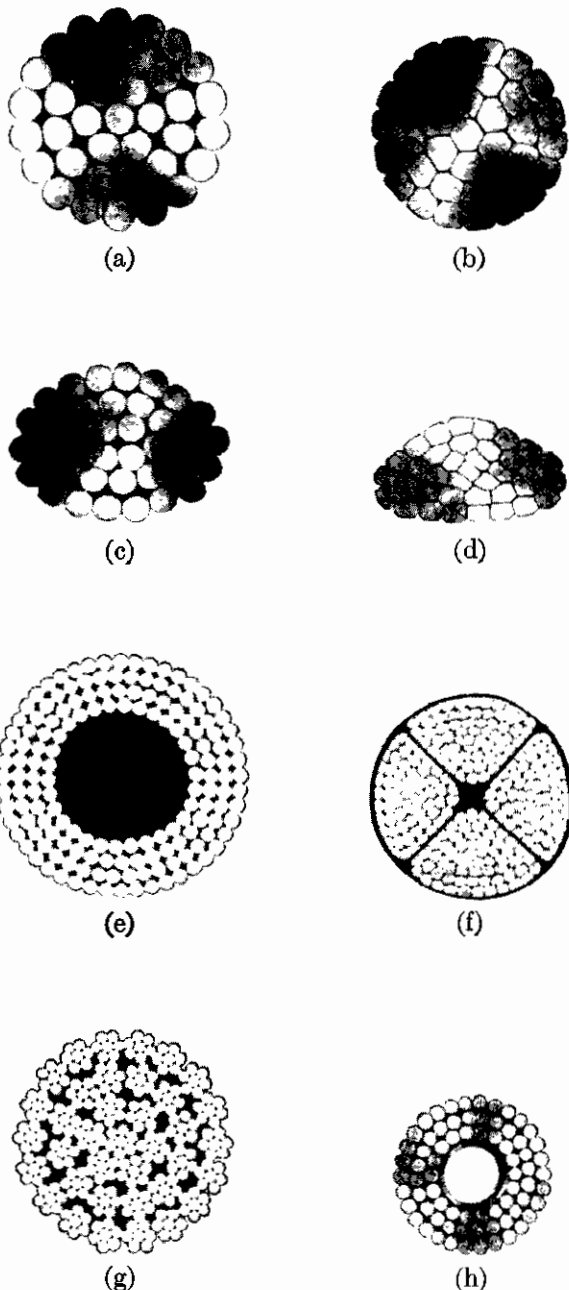

Fig. 4—Cross-sectional sketch of compression cable.



Photographs in this figure furnished by the Okonite-Callender Cable Company

Fig. 5—Cable conductors.

- (a) Standard concentric stranded.
- (b) Compact round.
- (c) Non-compact sector.
- (d) Compact sector.
- (e) Annular stranded (rope core).
- (f) Segmental.
- (g) Rope stranded.
- (h) Hollow core.

electrical breakdown; low a-c resistance due to minimizing of proximity effect; retention of the close stranding during bending; and for solid cables, elimination of many longitudinal channels along which impregnating compound can migrate. While most single-conductor cables are of the

concentric-strand type, they may also be compact-round, annular-stranded, segmental, or hollow-core.

I. ELECTRICAL CHARACTERISTICS

The electrical characteristics of cables have been discussed comprehensively in a series of articles¹ upon which much of the material presented here has been based. This chapter is primarily concerned with the determination of the electrical constants most commonly needed for power-system calculations, particular emphasis being placed on quantities necessary for the application of symmetrical components.² A general rule is that regardless of the complexity of mutual inductive relations between component parts of individual phases, the method of symmetrical components can be applied rigorously whenever there is symmetry among phases. All the three-conductor cables inherently satisfy this condition by the nature of their construction; single-conductor cables may or may not, although usually the error is small in calculating short-circuit currents. Unsymmetrical spacing and change in permeability resulting from different phase currents when certain methods of eliminating sheath currents are used, may produce dissymmetry.

Those physical characteristics that are of general interest in electrical application problems have been included along with electrical characteristics in the tables of this section.

All linear dimensions of radius, diameter, separation, or distance to equivalent earth return are expressed in inches in the equations in this chapter. This is unlike overhead transmission line theory where dimensions are in feet; the use of inches when dealing with cable construction seems appropriate. Many equations contain a factor for frequency, f , which is the circuit operating frequency in cycles per second.

1. Geometry of Cables

The space relationship among sheaths and conductors in a cable circuit is a major factor in determining reactance, capacitance, charging current, insulation resistance, dielectric loss, and thermal resistance. The symbols used in this chapter for various cable dimensions, both for single-conductor and three-conductor types, are given in Figs. 6 and 7. Several factors have come into universal use for defining the cross-section geometry of a cable circuit, and some of these are covered in the following paragraphs.^{1,2}

Geometric Mean Radius (GMR)—This factor is a property usually applied to the conductor alone, and depends on the material and stranding used in its construction. One component of conductor reactance³ is normally calculated by evaluating the integrated flux-linkages both inside and outside the conductor within an overall twelve-inch radius. Considering a solid conductor, some of the flux lines lie within the conductor and contribute to total flux-linkages even though they link only a portion of the total conductor current; if a tubular conductor having an infinitely thin wall were substituted for the solid conductor, its flux would necessarily all be external to the tube. A theoretical tubular conductor, in order to be inductively equivalent to a solid conductor, must have a smaller radius so

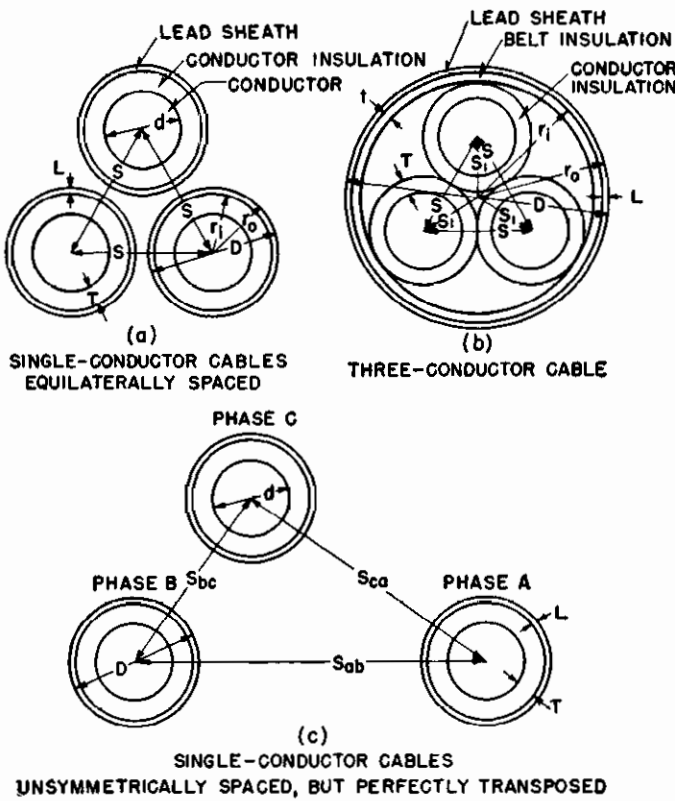

Fig. 6—Geometry of cables.

that the flux-linkages present inside the solid conductor but absent within the tube will be replaced by additional linkages between the tube surface and the limiting cylinder of twelve-inch radius. A solid copper conductor of radius $d/2$ can be replaced by a theoretical tubular conductor whose radius is $0.779 d/2$. This equivalent radius is called the geometric mean radius of the actual conductor, denoted herein by GMR_{1c} where the subscript denotes reference to only a single actual conductor. This quantity can be used in reactance calculations without further reference to the shape or make-up of the conductor. The factor by which actual radius must be multiplied to obtain GMR_{1c} varies with

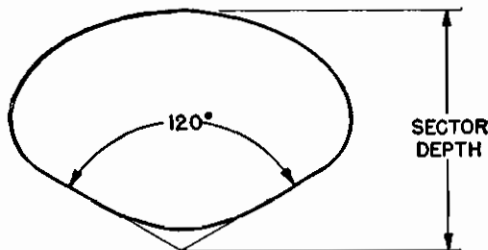

Fig. 7—Typical sector shape of conductor used in three-conductor cables.

stranding or hollow-core construction as shown in Chap. 3, Fig. 11. Sometimes in calculations involving zero-sequence reactances, simplification may result if the three conductors comprising a three-phase circuit are considered as a group and converted to a single equivalent conductor. This requires the use of a new GMR , denoted here as

GMR_{3c} , which applies to the group as though it were one complex conductor. This procedure is illustrated later in Eq. (18).

Geometric Mean Distance (GMD)—Spacings among conductors, or between conductors and sheaths, are important in determining total circuit reactance. The total flux-linkages surrounding a conductor can be divided into two components, one extending inward from a cylinder of 12-inch radius as discussed in the preceding paragraph, and the other extending outward from this cylinder to the current return path beyond which there are no net flux-linkages.³ The flux-linkages per unit conductor current between the 12-inch cylinder and the return path are a function of the separation between the conductor and its return. The return path can in many cases be a parallel group of wires, so that a geometric mean of all the separations between the conductor and each of its returns must be used in calculations. Geometric mean distance, therefore, is a term that can be used in the expression for external flux-linkages, not only in the simple case of two adjacent conductors where it is equal to the distance between conductor centers, but also in the more complex case where two circuits each composed of several conductors are separated by an equivalent GMD.

The positive- or negative-sequence reactance of a three-phase circuit depends on separation among phase conductors. If the conductors are equilaterally spaced the distance from one conductor center to another is equal to the GMD among conductors for that circuit. Using the terminology in Fig. 6,

$$GMD_{3c} = S \text{ for an equilateral circuit.}$$

The subscript here denotes that this GMD applies to separations among three conductors. If the conductors are arranged other than equilaterally, but transposed along their length to produce a balanced circuit, the equivalent separation may be calculated by deriving a geometric mean distance from the cube root of three distance products³ (see Chap. 3):

$$GMD_{3c} = \sqrt[3]{S_{ab} \cdot S_{bc} \cdot S_{ca}} \quad (1)$$

The component of circuit reactance caused by flux outside a twelve inch radius is widely identified as “reactance spacing factor” (x_d) and can be calculated directly from the GMD:

$$x_d = 0.2794 \frac{f}{60} \log_{10} \frac{GMD_{3c}}{12} \text{ ohms per phase per mile.} \quad (2)$$

When the equivalent separation is less than twelve inches, as can occur in cable circuits, the reactance spacing factor is negative so as to subtract from the component of conductor reactance due to flux out to a twelve-inch radius.

The zero-sequence reactance of a three-phase circuit may depend on spacing among conductors and sheath as well as among conductors. A distance that represents the equivalent spacing between a conductor or a group of conductors and the enclosing sheath can be expressed as a GMD. Also, the equivalent separation between cable conductors and the sheath of a nearby cable, or the equivalent separation between two nearby sheaths, can be expressed as a GMD. Because these and other versions² of geometric mean distance may be used successively in a single problem, care

must be taken to identify and distinguish among them during calculations.

Geometric Factor—The relation in space between the cylinders formed by sheath internal surface and conductor external surface in a single-conductor lead-sheathed cable can be expressed as a "geometric factor." This factor is applicable to the calculation of such cable characteristics as capacitance, charging current, dielectric loss, leakage current, and heat transfer, because these characteristics depend on a field or flow pattern between conductor and sheath. The mathematical expression for geometric factor G in a single conductor cable is

$$G = 2.303 \log_{10} \frac{2r_1}{d} \quad (3)$$

where:

r_1 = inside radius of sheath.
 d = outside diameter of conductor.

Geometric factors for single-conductor cables can be read from Fig. 8. Geometric factors for three-phase shielded cables having round conductors are identical, except for heat flow calculations, to those for single-conductor cables. The shielding layer establishes an equipotential surface surrounding each conductor just as a lead sheath does for single-conductor cables. The heat conductivity of the three-mil shielding tape is not high enough to prevent a temperature differential from developing around the shield circumference during operation: this poses a more complex problem than can be solved by the simple geometric factors given here.

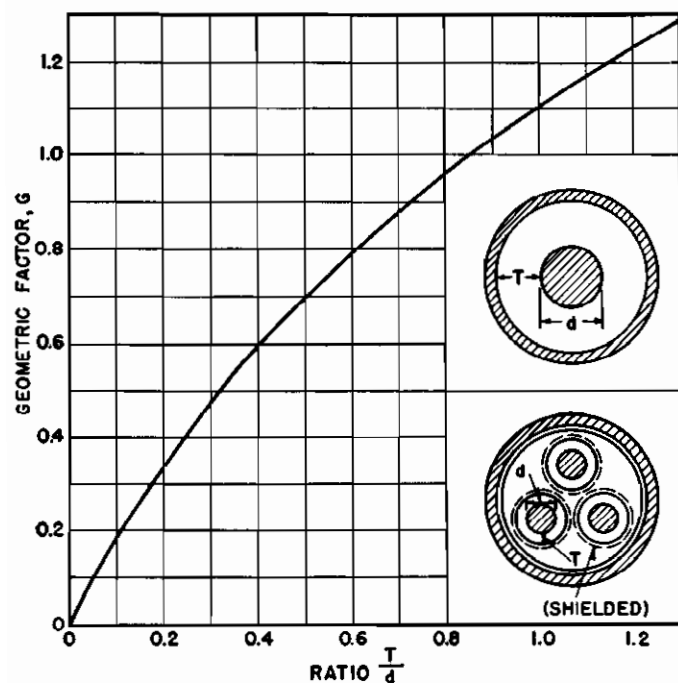

Fig. 8—Geometric factor for single-conductor cables, or three-conductor shielded cables having round conductors.

NOTE: This is approximately correct for shielded sector-conductor cables if curve is entered with the dimensions of a round-conductor cable having identical conductor area and insulation thickness. This geometric factor is not applicable for heat-flow calculations in shielded cables. See Secs. 5 and 6.

Because of the various possible combinations of conductors and sheaths that can be taken in a three-conductor belted cable, several geometric factors are required for complete definition. Two of these factors, the ones applicable to positive- and to zero-sequence electrical calculations, are shown in Fig. 9.

2. Positive- and Negative-Sequence Resistance

Skin Effect—It is well known that the resistance of a conductor to alternating current is larger than its resistance to direct current. The direct-current resistance in cables can be taken as the resistance of solid rod of the same length and cross-section, but increased two percent to take into account the effect of spiraling of the strands that compose the conductor. When alternating current flows in the conductor there is an unequal distribution of current, with the outer filaments of the conductor carrying more current than the filaments closer to the center. This results in a higher resistance to alternating current than to direct current, and is commonly called skin effect. The ratio of the two resistances is known as the skin-effect ratio. In small conductors this ratio is entirely negligible, but for larger conductors it becomes quite appreciable, and must be considered when figuring the 60-cycle resistances of large con-

TABLE 1—DIMENSIONS AND 60-CYCLE SKIN-EFFECT RATIO OF STRANDED COPPER CONDUCTORS AT 65°C.

Conductor Size (Circular Mils)	Round Concentric-Stranded		Inner Diameter of Annular Stranded Conductor, inches			
	Diameter inches	Ratio	0.50		0.75	
			Outer Diam.	Ratio	Outer Diam.	Ratio
211 600	0.528	1.00
250 000	0.575	1.005
300 000	0.630	1.006
400 000	0.728	1.012
500 000	0.814	1.018	0.97	1.01
600 000	0.893	1.026	1.04	1.01
800 000	1.031	1.046	1.16	1.02	1.28	1.01
1 000 000	1.152	1.068	1.25	1.03	1.39	1.02
1 500 000	1.412	1.145	1.52	1.09	1.63	1.06
2 000 000	1.631	1.239	1.72	1.17	1.80	1.12
2 500 000	1.825	1.336	1.91	1.24	2.00	1.20
3 000 000	1.998	1.439	2.08	1.36	2.15	1.29

ductors. Some skin-effect ratios are tabulated in Table 1 for stranded and representative hollow conductors.¹

Proximity Effect—The alternating magnetic flux in a conductor caused by the current flowing in a neighboring conductor gives rise to circulating currents, which cause an apparent increase in the resistance of a conductor. This phenomenon is called proximity effect. The increase in resistance is negligible except in very large conductors.

Proximity effect can, however, become important under certain conditions of cable installation. When cables are laid parallel to metal beams, walls, etc., as is frequently the case in buildings or ships, proximity effect increases the apparent impedance of these cables appreciably. Booth, Hutchings and Whitehead⁴ have made extensive tests on

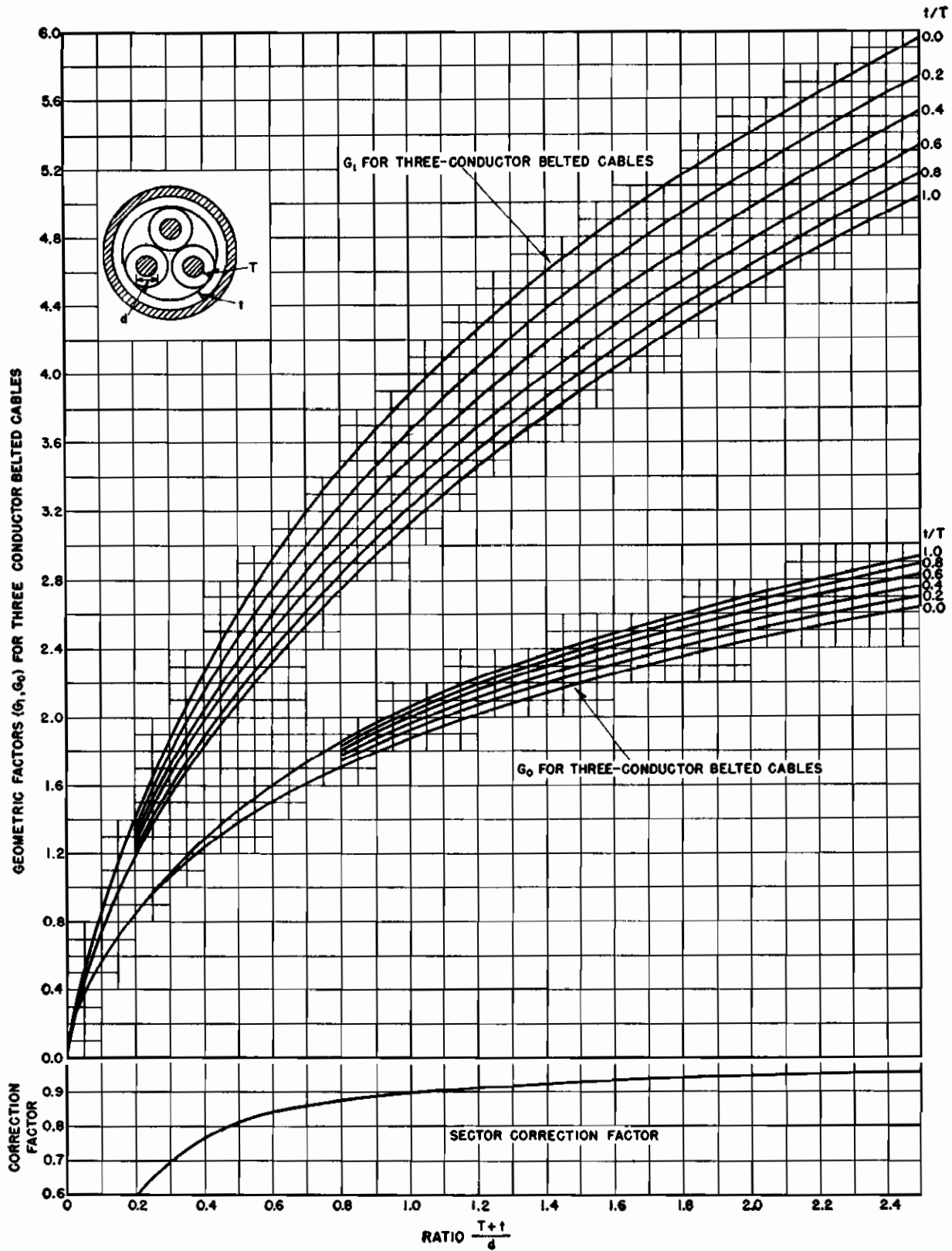

Fig. 9—Geometric factor for three-conductor belted cables having round or sector conductors.

NOTE: For cables having sector conductors, enter the curve with the dimensions of a round-conductor cable having identical conductor area and insulation thicknesses. Multiply the resultant geometric factor by the sector correction factor given above. (G_1 is calculated for three-phase operation; G_0 is calculated for single-phase operation, with three conductors paralleled and return in sheath. See Secs. 5 and 6.)

the impedance and current-carrying capacity of cables, as they are affected by proximity to flat plates of conducting and magnetic material. Figures 11 and 12, taken from this work, illustrate forcefully that proximity effect can be significantly large. Although these tests were performed at 50 cycles it is believed that the results serve to indicate effects that would be experienced at 60 cycles. The results in an actual installation of cables close to metal surfaces are influenced so greatly by the material involved, and by the

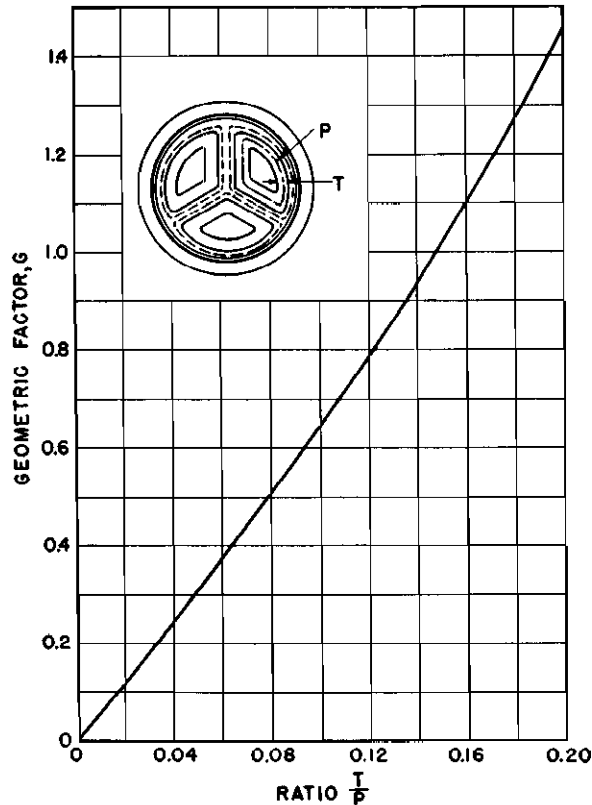

Fig. 10—Geometric factor for three-conductor shielded cables having sector conductors, in terms of insulation thickness T and mean periphery P .

structural shape of the surface, that calculation and prediction is difficult.

The additional losses caused by placing a metal plate or other structural shape close to a cable circuit arise from both hysteresis and eddy-current effects within the plate. Hysteresis losses are large if the flux density within the plate is high throughout a large proportion of the plate volume. A material having high permeability and very high resistivity would promote hysteresis loss, because flux developed by cable currents could concentrate within the low-reluctance plate, and because the action of eddy-currents to counteract the incident flux would be comparatively small in a high-resistance material. Eddy-current losses depend on the magnetic field strength at the plate, and also upon the resistance of the paths available for flow within the plate.

Because the factors that affect hysteresis loss and those that affect eddy-current loss are interdependent, it is seldom easy to theorize on which material or combination of ma-

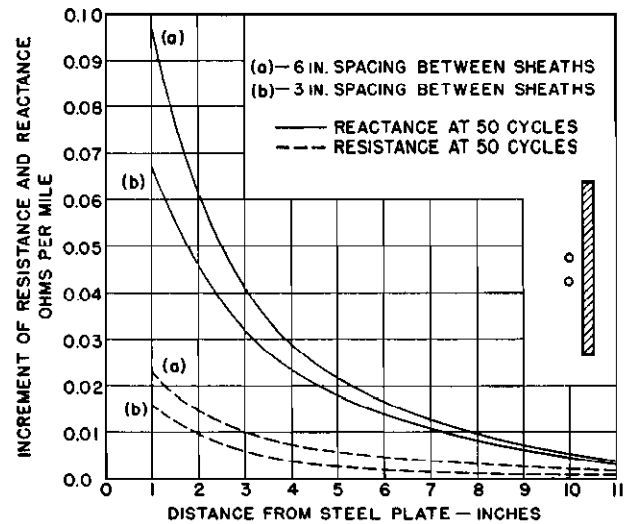

Fig. 11—Increase in cable resistance and reactance caused by proximity to steel plate for single phase systems (cable sheaths are insulated).

terials will contribute lowest losses. Some practical possibilities, drawn from experience in the design of switchgear, transformers, and generators, are listed here:

- The magnetic plate can be shielded by an assembly of laminated punchings, placed between the cables and the plate, so that flux is diverted from the plate and into the laminations. The laminations normally have low eddy-current losses and they must be designed so that flux density is not excessive.
- The magnetic plate can be shielded with a sheet of conducting material, such as copper or aluminum, placed so that the magnetic field acts to build up

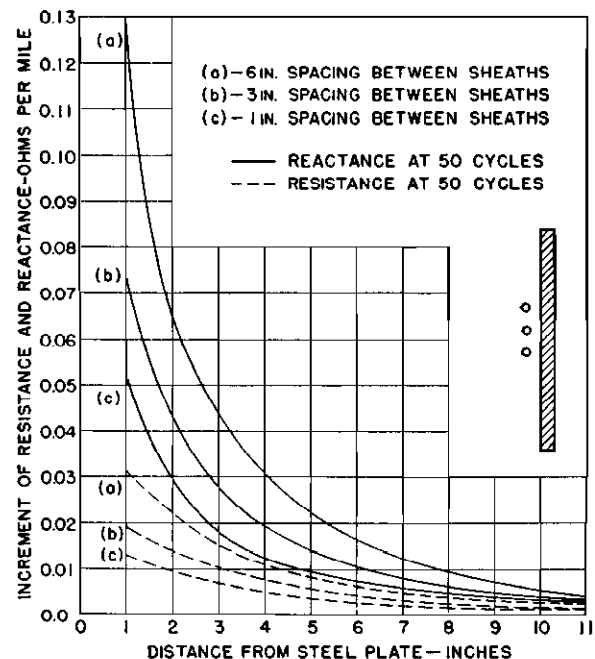

Fig. 12—Increase in cable resistance and reactance caused by proximity to steel plate for three-phase systems (cable sheaths are insulated).

counteracting circulating currents within the conducting sheet: these currents considerably reduce the magnetic field strength at the plate. The conducting sheet must have sufficient cross-sectional area to accommodate the currents developed.

- c. The magnetic material can be interleaved with conducting bars that are bonded at the ends so that circulating currents develop to counteract the incident magnetic field as in (b).
- d. The magnetic plate can be replaced, either entirely or partially, by a non-magnetic steel. Non-magnetic steel has low permeability and high resistivity when compared with conventional steel plate: these characteristics do not act in all respects to reduce losses, but the net effect is often a loss reduction. Non-magnetic steel is of particular benefit when the structure near the cable circuit partially or entirely surrounds individual phase conductors.

The effect of parallel metal on reactance is much larger than on resistance as Figs. 11 and 12 indicate. These figures also show that the magnitude of the increase in impedance is independent of conductor size. Actually, when large cables approach very close to steel, the resistance increments become higher and the reactance increments become somewhat lower. The curves of Figs. 11 and 12 are based on tests performed at approximately two-thirds of maximum current density for each cable used. The increments in resistance and reactance do not, however, change greatly with current density; the variation is only about 1 percent per 100 amperes. In three-phase systems the middle cable of the three is influenced less than the outer ones by the presence of the parallel steel. This variation again is less than variations in materials and has not been accounted for in Figs. 11 and 12. These curves cover only a few specific cases, and give merely an indication of the importance and magnitude of proximity effect. More detailed information can be found in the reference listed.⁴

Proximity effect also has an important bearing on the current-carrying capacity of cables when installed near steel plates or structures. This subject is discussed in the section on current-carrying capacity.

Sheath Currents in Cables—Alternating current in the conductors of single-conductor cables induces alternating voltages in the sheaths. When the sheaths are continuous and bonded together at their ends so that sheath currents may flow longitudinally, additional I^2R losses develop in the sheath. The common way to represent these losses is by increasing the resistance of the conductor involved. For single-conductor cables operating in three-phase systems, this increment in resistance can be calculated by the following equation, the derivation of which is given in references:^{1,2}

$$r = \frac{x_m^2 r_s}{x_m^2 + r_s^2} \text{ ohms per phase per mile.} \quad (4)$$

Here x_m is the mutual reactance between conductors and sheath in ohms per phase per mile, and r_s is the resistance of the sheath in ohms per phase per mile. These two quantities can be determined from the following equations:

$$x_m = 0.2794 \frac{f}{60} \log_{10} \frac{2S}{r_o + r_i} \text{ ohms per phase per mile.} \quad (5)$$

and

$$r_s = \frac{0.200}{(r_o + r_i)(r_o - r_i)} \text{ ohms per phase per mile, for lead sheath.} \quad (6)$$

in which

S = spacing between conductor centers in inches.

r_o = outer radius of lead sheath in inches.

r_i = inner radius of lead sheath in inches.

Thus the total resistance (r_a) to positive- or negative-sequence current flow in single-conductor cables, including the effect of sheath currents, is

$$r_a = r_o + \frac{x_m^2 r_s}{x_m^2 + r_s^2} \text{ ohms per phase per mile.} \quad (7)$$

where r_o is the alternating-current resistance of the conductor alone including skin effect at the operating frequency. Eq. (7) applies rigorously only when the cables are in an equilateral triangular configuration. For other arrangements the geometric mean distance among three conductors, GMD_{3c} , can be used instead of S with results sufficiently accurate for most practical purposes.

The sheath loss in a three-conductor cable is usually negligible except for very large cables and then it is important only when making quite accurate calculations. In these largest cables the sheath losses are about 3 to 5 percent of the conductor loss, and are of relatively little importance in most practical calculations. When desired the sheath loss in three-conductor cables can be calculated from the equivalent resistance,

$$r = \frac{44160(S_1)^2}{r_s(r_o + r_i)^2} \times 10^{-6} \text{ ohms per phase per mile.} \quad (8)$$

where

r_s is sheath resistance from Eq. (6).

r_o and r_i are sheath radii defined for Eq. (5).

$$S_1 = \frac{1}{\sqrt{3}}(d + 2T), \text{ and is the distance between conductor center and sheath center for three-conductor cables made up of round conductors.} \quad (9)$$

d = conductor diameter.

T = conductor insulation thickness.

For sector-shaped conductors an approximate figure can be had by using Eq. (8), except that d should be 82 to 86 percent of the diameter of a round conductor having the same cross-sectional area.

Example 1—Find the resistance at 60 cycles of a 750 000 circular-mil, three-conductor belted cable having 156 mil conductor insulation and 133 mil lead sheath. The overall diameter of the cable is 2.833 inches and the conductors are sector shaped.

From conductor tables (see Table 10) the diameter of an equivalent round conductor is 0.998 inches. From Eq. (9),

$$S_1 = \frac{1}{\sqrt{3}}[0.998(0.84) + 2(0.156)] = 0.664 \text{ inches.}$$

Since the overall diameter is 2.833 inches,

$$r_o = 1.417 \text{ inches}$$

and

$$r_i = 1.284 \text{ inches.}$$

From Eq. (6),

$$\begin{aligned} r_a &= \frac{0.200}{(2.701)(0.133)} \\ &= 0.557 \text{ ohms per phase per mile.} \end{aligned}$$

Substituting in Eq. (8),

$$\begin{aligned} r &= \frac{44160(0.664)^2}{0.557(2.701)^2} \times 10^{-6} \\ &= 0.00479 \text{ ohms per phase per mile.} \end{aligned}$$

From Table 6 it is found that r_c , the conductor resistance, including skin effect is 0.091 ohms per phase per mile. The total positive- and negative-sequence resistance is then,

$$r_a = 0.091 + .005 = 0.096 \text{ ohms per phase per mile.}$$

Sheath currents obviously have little effect on the total alternating-current resistance of this cable.

Theoretically some allowance should be made for the losses that occur in the metallic tape on the individual conductors of shielded cable, but actual measurements indicate that for all practical purposes these losses are negligible with present designs and can be ignored in most cases. The resistance to positive- and negative-sequence in shielded cable can be calculated as though the shields were not present.

Three Conductors in Steel Pipe—Typical values for positive- and negative-sequence resistance of large pipe-type cables have been established by test⁵, and an empirical calculating method has been proposed by Wiseman⁶ that checks the tests quite closely. Because the calculations are complex, only an estimating curve is presented

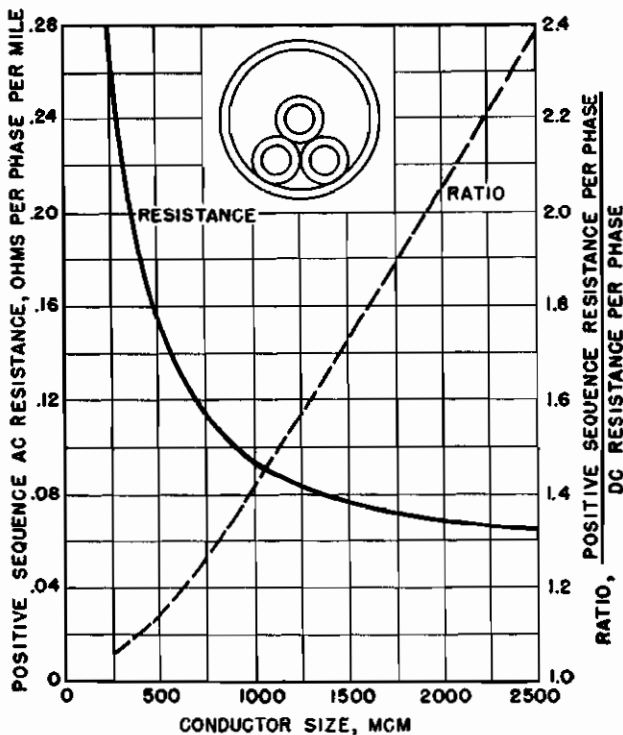

Fig. 13—Positive-sequence resistance of high-voltage cables in steel pipe (estimating curve).

here. The ratio of actual resistance as installed to the d-c resistance of the conductor itself based on data obtained in laboratory tests is shown in Fig. 13. The increased resistance is due to conductor skin effect, conductor proximity effect in the presence of steel pipe, and to I^2R loss in the pipe itself. In preparing Fig. 13, the pipe size assumed for each cable size was such that 60 percent of the internal pipe cross-sectional area would have been unoccupied by cable material: choosing a nearest standard pipe size as a practical expedient does not affect the result appreciably. The conductor configuration for these tests was a triangular grouping, with the group lying at the bottom of the pipe. If, instead, the conductors were to be laid in an approximately flat cradled arrangement, some change in resistance would be expected. Actual tests on the flat arrangement produced variable results as conductor size was changed, some tests giving higher losses and some lower than the triangular. If a maximum value is desired, an estimated increase of 15 percent above the resistance for triangular configuration can be used. Field tests have been made on low-voltage circuits by Brieger¹⁴, and these results are shown in Table 2.

3. Positive- and Negative-Sequence Reactances

Single-Conductor Cables—The reactance of single-conductor lead-sheathed cables to positive- and negative-sequence currents can be calculated from the following equation, which takes into account the effect of sheath currents.

$$x_1 = x_2 = 0.2794 \frac{f}{60} \log_{10} \frac{\text{GMD}_{3c}}{\text{GMR}_{1c}} \frac{x_m^3}{x_m^2 + r_s^2} \text{ ohms per phase per mile.} \quad (10)$$

or

$$x_1 = x_2 = x_a + x_d - \frac{x_m^3}{x_m^2 + r_s^2} \text{ ohms per phase per mile.} \quad (11)$$

The conductor component of reactance is

$$x_a = 0.2794 \frac{f}{60} \log_{10} \frac{12}{\text{GMR}_{1c}} \quad (12)$$

where

GMR_{1c} = geometric mean radius of one conductor.

The separation component of reactance is

$$x_d = 0.2794 \frac{f}{60} \log_{10} \frac{\text{GMD}_{3c}}{12} \quad (13)$$

where

GMD_{3c} = geometric mean distance among three conductors (see Eq. 1).

The component to be subtracted¹ because of the effect of sheath currents is composed of terms defined by Eqs. (5) and (6).

Three-Conductor Cables—Because negligible sheath current effects are present in three-conductor non-shielded cables, the reactance to positive- and negative-sequence currents can be calculated quite simply as:

$$x_1 = x_2 = 0.2794 \frac{f}{60} \log_{10} \frac{\text{GMD}_{3c}}{\text{GMR}_{1c}} \text{ ohms per phase per mile} \quad (14)$$

or

$$x_1 = x_2 = x_a + x_d \text{ ohms per phase per mile} \quad (15)$$

TABLE 2—IMPEDANCE OF THREE-PHASE 120/208 VOLT CABLE CIRCUITS IN FIBRE AND IN IRON CONDUITS.¹

Positive- and Negative-Sequence Impedance, Ohms per Phase per Mile at 60 Cycles.

Phase Conductor Size	Conductor Assembly	Duct Material (4 inch)	Cable Sheath (Phase Conductors)	Resistance (Ohms at 25°C.)	Reactance (Ohms)
500 MCM (1 per phase)	Uncabled ²	Fibre	Non-leaded	0.120	0.180
			Lead	0.127	0.188
		Iron	Non-leaded	0.135	0.229
			Lead	0.156	0.236
	Cabled ³	Fibre	Non-leaded	0.125	0.169
		Iron	Non-leaded	0.135	0.187
	Cabled ⁴	Fibre	Non-leaded	0.136	0.144
		Iron	Non-leaded	0.144	0.159
0000 AWG (2 per phase)	Uncabled ⁵	Fibre	Non-leaded	0.135	0.101
		Iron	Non-leaded	0.144	0.152
		Lead	0.143	0.113	
	Cabled ⁶	Fibre	Non-leaded	0.137	0.079
		Iron	Non-leaded	0.137	0.085

Zero-Sequence Impedance, Ohms Per Phase Per Mile at 60 Cycles.

Phase Conductor Size	Neutral Conductor Size	Conductor Assembly	Duct Material (4 inch)	Cable Sheath (Phase Conductors)	Resistance (Ohms at 25°C.)	Reactance (Ohms)
500 MCM (1 per phase)	0000 AWG (1 conductor, bare)	Uncabled ²	Fibre	Non-leaded	0.972	0.814
			Lead	0.777	0.380	
		Iron	Lead	0.729	0.349	
			Uncabled ²	Iron	Non-leaded	0.539
	Cabled ³	Fibre	Non-leaded	0.539	0.566	
		Iron	Non-leaded	0.534	0.603	
000 AWG (3 conductors, bare)	Cabled ⁴	Fibre	Non-leaded	0.471	0.211	
		Iron	Non-leaded	0.433	0.264	
	Uncabled ⁵	Fibre	Non-leaded	1.015	0.793	
		Iron	Non-leaded	0.707	0.676	
0000 AWG (2 per phase)	0000 AWG (1 conductor, bare)	Uncabled ⁵	Lead	0.693	0.328	
			Non-leaded	0.583	0.475	
			Iron	Non-leaded	0.629	0.538
	500 MCM (1 conductor, bare)	Cabled ⁶	Iron	Non-leaded	0.497	0.359

¹ Material taken from "Impedance of Three-Phase Secondary Mains in Non-Metallic and Iron Conduits," by L. Brieger, EET Bulletin, Vol. 6, No. 2, pg. 61, February 1938.² Assembly of four conductors arranged rectangularly, in the sequence (clockwise) A-B-C-neutral, while being pulled into the duct; conductors may assume a random configuration after entering the duct.³ Assembly as in note 2, except that conductors are cabled in position.⁴ Assembly of three phase conductors arranged triangularly with three neutral conductors interposed in the spaces between phase conductors. All conductors are cabled in position.⁵ Assembly of six phase conductors arranged hexagonally, in the sequence A-B-C-A-B-C, with either one or two neutral conductors inside the phase conductor group. This arrangement is maintained only at the duct entrance; a random configuration may develop within the duct.⁶ Assembly as in note 5, except that conductors are cabled in position.

where:

$GMD_{3c} = S =$ geometric mean distance among three conductors, and the remaining values are as defined in Eqs. (12) and (13).

For sector-shaped conductors no accurate data on change in reactance because of conductor shape is available, but Dr. Simmons can be quoted as authority for the statement that the reactance is from five to ten percent less than for round conductors of the same area and insulation thickness.

For shielded three-conductor cables the reactance to positive- and negative-sequence currents can be calculated as though the shields were not present, making it similar to belted three-conductor cable. This is true because the effect on reactance of the circulating currents in the shielding tapes has been calculated by the method used for determining sheath effects in single-conductor cables and proves to be negligible.

Three Conductors in Steel Pipe—Conductor skin effect and proximity effects influence the apparent reactance of high-voltage cables in steel pipe. Because the detailed

calculation of these factors is complex, a curve is supplied in Fig. 14 that serves for estimating reactance within about five percent accuracy. The curve is drawn for triangular conductor grouping, with the group lying at the bottom of the pipe. If the grouping is instead a flat cradled arrangement, with the conductors lying side-by-side at the bottom of the pipe, the curve results should be increased by 15 percent. A calculating method that accounts in detail for

of these inductive effects cannot always be identified individually from the equations to be used for reactance calculations because the theory of earth return circuits³, and the use of one GMR to represent a paralleled conductor group, present in combined form some of the fundamental effects contributing to total zero-sequence reactance. The resistance and reactance effects are interrelated so closely that they are best dealt with simultaneously.

Cable sheaths are frequently bonded and grounded at several points, which allows much of the zero-sequence return current to flow in the sheath. On the other hand, when any of the various devices used to limit sheath current are employed, much or all of the return current flows in the earth. The method of bonding and grounding, therefore, has an effect upon the zero-sequence impedance of cables. An actual cable installation should approach one of these three theoretical conditions:

- 1 Return current in sheath and ground in parallel.
- 2 All return current in sheath, none in ground.
- 3 All return current in ground, none in sheath.

Three-Conductor Cables—Actual and equivalent circuits for a single-circuit three-conductor cable having a solidly bonded and grounded sheath are shown in Fig. 15 (a) and (c). The impedance of the group of three paralleled conductors, considering the presence of the earth return but ignoring for the moment the presence of the sheath, is given in Eqs. (16) or (17) in terms of impedance to zero-sequence currents.

$$z_0 = r_c + r_e + j0.8382 \frac{f}{60} \log_{10} \frac{D_e}{GMR_{3c}}$$

ohms per phase per mile (16)

or

$$z_0 = r_c + r_e + j(x_a + x_e - 2x_d)$$

ohms per phase per mile. (17)

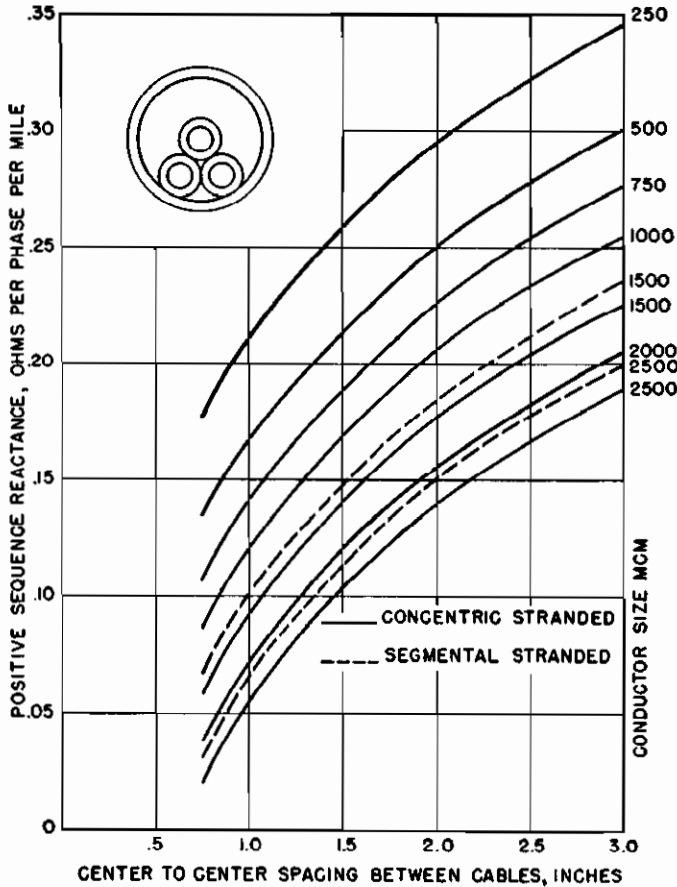

Fig. 14—Positive-sequence reactance of high-voltage cables in steel pipe (estimating curve).

the variable factors in this problem has been presented by Del Mar⁷. Table 2 contains information¹⁴ useful in estimating the impedance of low-voltage (120/208 volt) cables in iron conduit.

4. Zero-Sequence Resistance and Reactance

When zero-sequence current flows along the phase conductors of a three-phase cable circuit, it must return in either the ground, or the sheaths, or in the parallel combination of both ground and sheaths.² As zero-sequence current flows through each conductor it encounters the a-c resistance of that conductor, and as it returns in the ground or sheaths it encounters the resistance of those paths. The zero-sequence current flowing in any one phase encounters also the reactance arising from conductor self-inductance, from mutual inductance to the other two phase conductors, from mutual inductance to the ground and sheath return paths, and from self-inductance of the return paths. Each

TABLE 3—EQUIVALENT DEPTH OF EARTH RETURN (D_e), AND EARTH IMPEDANCE (r_e AND x_e), AT 60 CYCLES

Earth Resistivity (meter-ohm)	Equivalent Depth of Earth Return, D_e		Equivalent Earth Resistance r_e (ohms per mile)	Equivalent Earth Reactance x_e (ohms per mile)
	inches	feet		
1	3.36×10^3	280	0.286	2.05
5	7.44×10^3	620	0.286	2.34
10	1.06×10^4	880	0.286	2.47
50	2.40×10^4	2 000	0.286	2.76
100	3.36×10^4	2 800	0.286	2.89
500	7.44×10^4	6 200	0.286	3.18
1 000	1.06×10^5	8 800	0.286	3.31
5 000	2.40×10^5	20 000	0.286	3.60
10 000	3.36×10^5	28 000	0.286	3.73

where:

- r_c = a-c resistance of one conductor, ohms per mile.
- r_e = a-c resistance of earth return (See Table 3), ohms per mile.
- D_e = distance to equivalent earth return path, (See Table 3), inches.

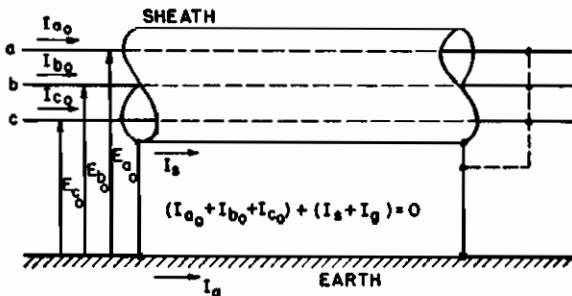

ACTUAL CIRCUIT
(ONE THREE-CONDUCTOR CABLE)
(a)

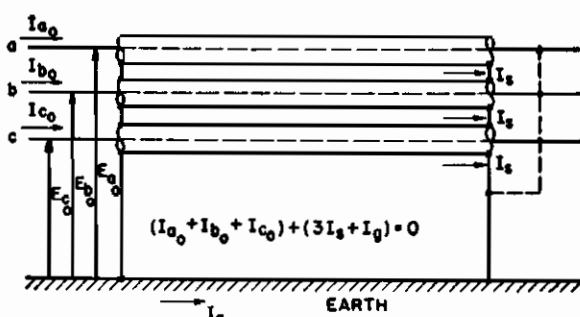

ACTUAL CIRCUIT
(THREE SINGLE-CONDUCTOR CABLES)
(b)

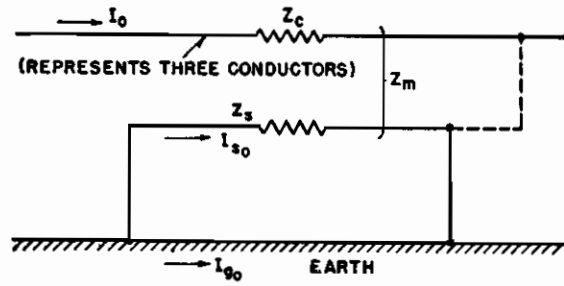

EQUIVALENT CIRCUIT
(IMPEDANCES EXPRESSED IN ZERO SEQUENCE TERMS)
(c)

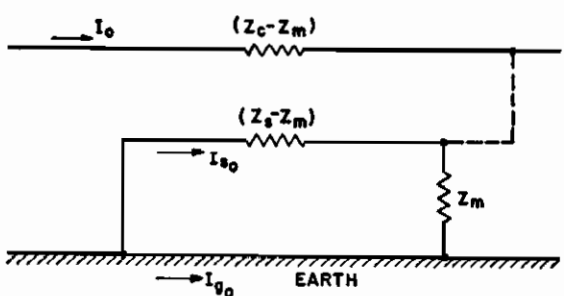

MODIFIED EQUIVALENT CIRCUIT
(IMPEDANCES EXPRESSED IN ZERO-SEQUENCE TERMS)
(d)

GMR_{3c} = geometric mean radius of the conducting path made up of the three actual conductors taken as a group, inches.
 $= \sqrt[3]{(GMR_{1c})(S)^2}$ for round conductors. (18)

GMR_{1c} = geometric mean radius of an individual conductor, inches.
 x_a = reactance of an individual phase conductor at twelve inch spacing, ohms per mile.
 x_e = reactance of earth return.
 $= 0.8382 \frac{f}{60} \log_{10} \frac{D_o}{12}$ ohms per mile. (Refer to Table 3). (19)

$$x_d = 0.2794 \frac{f}{60} \log_{10} \left(\frac{GMD_{3c}}{12} \right), \text{ ohms per mile.}$$

GMD_{3c} = geometric mean distance among conductor centers, inches.
 $= S = (d + 2T)$ for round conductors in three conductor cables.

The impedance of the sheath, considering the presence of the earth return path but ignoring for the moment the presence of the conductor group, is given in terms of impedance to zero-sequence currents:

$$z_s = 3r_s + r_e + j0.8382 \frac{f}{60} \log_{10} \frac{2D_o}{r_o + r_i} \text{ ohms per phase per mile.} \quad (20)$$

or

$$z_s = 3r_s + r_e + j(3x_s + x_e) \text{ ohms per phase per mile.} \quad (21)$$

where:

- r_s = sheath resistance, ohms per mile.
 $= \frac{0.200}{(r_o + r_i)(r_o - r_i)}$ for lead sheaths.
- r_i = inside radius of sheath, inches.
- r_o = outside radius of sheath, inches.
- x_s = reactance of sheath, ohms per mile.
 $= 0.2794 \frac{f}{60} \log_{10} \frac{24}{r_o + r_i}$ ohms per mile. (22)

The mutual impedance between conductors and sheath, considering the presence of the earth return path which is common to both sheath and conductors, in zero-sequence terms is

$$z_m = r_e + j0.8382 \frac{f}{60} \log_{10} \frac{2D_o}{r_o + r_i} \text{ ohms per phase per mile.} \quad (23)$$

or

$$z_m = r_e + j(3x_s + x_e) \text{ ohms per phase per mile.} \quad (24)$$

The equivalent circuit in Fig. 15(d) is a conversion from the one just above it, and combines the mutual impedance into a common series element. From this circuit, when both ground and sheath return paths exist, total zero-sequence impedance is:

$$z_0 = (z_o - z_m) + \frac{(z_s - z_m)z_m}{z_s} = z_o - \frac{z_m^2}{z_s} \text{ ohms per phase per mile.} \quad (25)$$

Fig. 15—Actual and equivalent zero-sequence circuits for three-conductor and single-conductor lead-sheathed cables.

If current returns in the sheath only, with none in the ground:

$$\begin{aligned} z_0 &= (z_c - z_m) + (z_s - z_m) \\ &= z_c + z_s - 2z_m \end{aligned} \quad (26)$$

$$= r_c + 3r_s + j0.8382 \frac{f}{60} \log_{10} \frac{r_c + r_s}{2(\text{GMR}_{3c})} \text{ ohms per phase per mile.} \quad (27)$$

$$= r_c + 3r_s + j(x_s - 2x_d - 3x_a) \text{ ohms per phase per mile.} \quad (28)$$

If current returns in ground only with none in the sheath, as would be the case with non-sheathed cables or with insulating sleeves at closely spaced intervals, the zero-sequence impedance becomes:

$$\begin{aligned} z_0 &= (z_c - z_m) + z_m \\ &= z_c \text{ ohms per phase per mile.} \end{aligned} \quad (29)$$

The zero-sequence impedance of shielded cables can be calculated as though the shielding tapes were not present because the impedance is affected only slightly by circulating currents in the shields.

The equivalent geometric mean radius (GMR_{3c}) for three-conductor cables having sector conductors is difficult to calculate accurately. The method used to calculate values of GMR_{3c} for the tables of characteristics is of practical accuracy, but is not considered to be appropriate for explanation here. As an alternate basis for estimations, it appears that the GMR_{3c} for three sector-conductors is roughly 90 percent of the GMR_{3c} for three round conductors having the same copper area and the same insulation thickness.

Example 2—Find the zero-sequence impedance of a three-conductor belted cable, No. 2 A.W.G. conductor (7 strands) with conductor diameter of 0.292 inches. Conductor insulation thickness is 156 mils, belt insulation is 78 mils, lead sheath thickness is 109 mils, and overall cable diameter is 1.732 inches. Assume $D_e = 2800$ feet and resistance of one conductor = 0.987 ohms per mile at 60 cycles. Distance between conductor centers is:

$$S = 0.292 + 2 \times 0.156 = 0.604 \text{ inches.}$$

GMR of one conductor is (see Chap. 3, Fig. 11):

$$\text{GMR}_{1c} = 0.726 \times 0.146 = 0.106 \text{ inches.}$$

GMR of three conductors is:

$$\text{GMR}_{3c} = \sqrt[3]{(0.106)(0.604)^2} = 0.338 \text{ inches.}$$

The conductor component of impedance is

$$\begin{aligned} (r_c = 0.987, r_e = 0.286): \\ z_c &= 0.987 + 0.286 + j0.8382 \log_{10} \frac{2800 \times 12}{0.338} \\ &= 1.27 + j4.18 = 4.37 \text{ ohms per mile.} \end{aligned}$$

This would represent total zero-sequence circuit impedance if all current returned in the ground, and none in the sheath.

For the sheath component of impedance:

$$\begin{aligned} r_s &= \frac{0.200}{(1.623)(0.109)} = 1.13 \text{ ohms per mile} \\ z_s &= 3 \times 1.13 + 0.286 + j0.8382 \log_{10} \frac{2 \times 2800 \times 12}{1.623} \\ &= 3.68 + j3.87 \text{ ohms per mile} \end{aligned}$$

The mutual component of impedance is:

$$z_m = 0.286 + j3.87$$

If all current returned the sheath, and none in the ground,

$$\begin{aligned} z_0 &= 1.27 + j4.18 + 3.68 + j3.87 - 0.57 - j7.74 \\ &= 4.38 + j0.31 = 4.39 \text{ ohms per mile.} \end{aligned}$$

If return current may divide between the ground and sheath paths,

$$\begin{aligned} z_0 &= 1.27 + j4.18 - \frac{(0.286 + j3.87)^2}{3.68 + j3.87} \\ &= 1.27 + j4.18 + 1.623 - j2.31 \\ &= 2.89 + j1.87 = 3.44 \text{ ohms per mile.} \end{aligned}$$

The positive-sequence impedance of this cable is:

$$z_1 = 0.987 + j0.203 \text{ ohms per mile.}$$

Therefore the ratio of zero- to positive-sequence resistance is 2.9, and the ratio of zero- to positive-sequence reactance is 9.2.

Zero-sequence impedance is often calculated for all return current in the sheath and none in the ground, because the magnitude of the answer is usually close to that calculated considering a paralleled return. The actual nature of a ground-return circuit is usually indefinite, since it may be mixed up with water pipes and other conducting materials, and also because low-resistance connections between sheath and earth are sometimes difficult to establish.

Single-Conductor Cables—Fig. 15 also shows the actual and equivalent circuits for three single-conductor cables in a perfectly transposed three-phase circuit, where the sheaths are solidly bonded and grounded. The impedance expressions applying to single-conductor cables differ in some respects from those for three-phase cables:

$$\begin{aligned} z_c &= r_c + r_e + j0.8382 \frac{f}{60} \log_{10} \frac{D_e}{\text{GMR}_{3c}} \text{ ohms} \\ &\text{per phase per mile.} \end{aligned} \quad (30)$$

or

$$\begin{aligned} z_c &= r_c + r_e + j(x_s + x_e - 2x_d) \text{ ohms} \\ &\text{per phase per mile.} \end{aligned} \quad (31)$$

where:

r_c = a.c. resistance of one conductor, ohms per mile.

r_e = a.c. resistance of earth (see Table 3), ohms per mile.

D_e = distance to equivalent earth return path (see Table 3), inches.

GMR_{3c} = geometric mean radius of the conducting path made up of the three actual conductors taken as a group, inches.

$$= \sqrt[3]{(\text{GMR}_{1c})(\text{GMD}_{3c})^2}$$

x_s = reactance of an individual phase conductor at twelve-inch spacing, ohms per mile.

x_e = reactance of earth return.

$$= 0.8382 \frac{f}{60} \log_{10} \frac{D_e}{12} \text{ ohms per mile.}$$

(See Table 3.)

$$x_d = 0.2794 \frac{f}{60} \log_{10} \left(\frac{\text{GMD}_{3c}}{12} \right), \text{ ohms per mile.}$$

GMD_{3c} = geometric mean distance among conductor centers, inches.
 $= \sqrt[3]{S_{ab} \cdot S_{bc} \cdot S_{ca}}$.

$$z_a = r_a + r_e + j0.8382 \frac{f}{60} \log_{10} \frac{D_e}{GMR_{3c}} \text{ ohms per phase per mile} \quad (32)$$

or

$$z_a = r_a + r_e + j(x_a + x_e - 2x_d) \text{ ohms per phase per mile} \quad (33)$$

where:

GMR_{3c} = geometric mean radius of the conducting path made up of the three sheaths in parallel

$$= \sqrt[3]{\left(\frac{r_o + r_i}{2}\right) (GMD_{3c})^2}$$

r_a = resistance of one sheath, ohms per mile
 $= \frac{0.200}{(r_o + r_i)(r_o - r_i)}$ for lead sheaths.

r_i = inside radius of sheath, inches.

r_o = outside radius of sheath, inches.

x_a = reactance of one sheath, ohms per mile

$$= 0.2794 \frac{f}{60} \log_{10} \frac{24}{r_o + r_i}$$

$$z_m = r_o + j0.8382 \frac{f}{60} \log_{10} \frac{D_e}{GMD_{3c-3s}} \text{ ohms per phase per mile.} \quad (34)$$

or

$$z_m = r_e + j(x_a + x_e - 2x_d) \text{ ohms per phase per mile.} \quad (35)$$

where:

GMD_{3c-3s} = geometric mean of all separations between sheaths and conductors.

$$= \sqrt[9]{\left(\frac{r_o + r_i}{2}\right)^3 (GMD_{3c})^6} = \sqrt[3]{\left(\frac{r_o + r_i}{2}\right) (GMD_{3c})^2}$$

From the equivalent circuit of Fig. 15, total zero-sequence impedance when both ground and sheath paths exist is:

$$z_0 = z_c - \frac{z_m^2}{z_s} \text{ ohms per phase per mile.} \quad (25)$$

If current returns in the sheath only, with none in the ground:

$$z_0 = z_c + z_s - 2z_m \text{ ohms per phase per mile} \quad (26)$$

$$= r_o + r_a + 0.8382 \log_{10} \frac{GMR_{3s}}{GMR_{3c}} \text{ ohms per phase per mile.} \quad (36)$$

$$= r_o + r_a + j(x_a - x_s) \text{ ohms per phase per mile.} \quad (37)$$

If current returns in the ground only:

$$z_0 = (z_c - z_m) + z_m = z_c \text{ ohms per phase per mile.} \quad (29)$$

Cables in Steel Pipes or Conduits—When cables are installed in iron conduits or steel pipes, the zero-sequence resistance and reactance are affected by the magnetic material because it closely surrounds the phase conductors and forms a likely return path for zero-sequence current. No method of calculating this zero-sequence impedance is available, but some rather complete results are available from field tests on installed low-voltage cables, as shown

in Table 2. Some special tests of the zero-sequence impedance of high-voltage pipe-type cable have been made but the results are not yet of a sufficiently wide scope to be generally usable.

5. Shunt Capacitive Reactance

Shunt capacitive reactances of several types of cables are given in the Tables of Electrical Characteristics, directly in ohms per mile. In addition, shunt capacitance and charging current can be derived from the curves of geometric factors shown in Figs. 8 and 9, for any cable whose dimensions are known. The geometric factors given in these curves are identified by symmetrical-component terminology.

The positive-, negative-, and zero-sequence shunt capacitances for single-conductor metallic-sheathed cables are all equal, and can be derived from the curves of Fig. 8. Three-conductor shielded cables having round conductors are similar to single-conductor cable in that each phase conductor is surrounded by a grounded metallic covering; therefore the positive-, negative-, and zero-sequence values are equal and are dependent upon the geometric factor relating a conductor to its own shielding layer. The geometric factor for three-conductor shielded cables having sector-shaped conductors is approximately equal to the geometric factor, G , applying to round conductors. However, if the sector shape of a shielded cable is known, then the curve in Fig. 10, based on insulation thickness and mean periphery of insulation, is recommended as giving more accurate values of geometric factor.

For single-conductor and three-conductor shielded cables (see Fig. 8),

$$C_1 = C_2 = C_0 = \frac{0.0892k}{G} \text{ microfarads per phase per mile.} \quad (38)$$

$$x_1' = x_2' = x_0' = \frac{1.79G}{f \cdot k} \text{ megohms per phase per mile.} \quad (39)$$

$$I_1' = I_2' = I_0' = \frac{0.323f \cdot k \cdot kv}{1000G} \text{ amperes per phase per mile.} \quad (40)$$

Three-conductor belted cables having no conductor shielding have zero-sequence values which differ from the positive- and negative-sequence; the appropriate geometric factors are given in Fig. 9;

$$C_1 = C_2 = \frac{0.267k}{G_1} \text{ microfarads per phase per mile.} \quad (41)$$

$$C_0 = \frac{0.0892k}{G_0} \text{ microfarads per phase per mile.} \quad (42)$$

$$x_1' = x_2' = \frac{0.597G_1}{f \cdot k}, \text{ megohms per phase per mile.} \quad (43)$$

$$x_0' = \frac{1.79G_0}{f \cdot k} \text{ megohms per phase per mile.} \quad (44)$$

$$I_1' = I_2' = \frac{0.97f \cdot k \cdot kv}{1000G_1} \text{ amperes per phase per mile.} \quad (45)$$

$$I_0' = \frac{0.323f \cdot k \cdot kv}{1000G_0} \text{ amperes per phase per mile.} \quad (46)$$

When three-conductor belted cables have sector-shaped conductors, the geometric factor must be corrected from the value which applies to round conductors. This correction factor is plotted in Fig. 9, and its use is explained below the curve.

In the foregoing equations,

C_1 , C_2 , and C_0 are positive-, negative-, and zero-sequence capacitances.

x_1 , x_2 and x_0 are positive-, negative-, and zero-sequence capacitive reactances.

I_1 , I_2 and I_0 are positive-, negative-, and zero-sequence charging currents.

kv = line-to-line system voltage, kilovolts.

k = dielectric constant, according to the values in Table 4.

It is important to note that in converting shunt capacitive reactance from an "ohms per phase per mile" basis to a total "ohms per phase" basis, it is necessary to divide by the circuit length:

$$X_{c'} = \frac{x_{c'}}{l, \text{ length in miles}}, \text{ ohms per phase.} \quad (47)$$

6. Insulation Resistance.

The calculation of cable insulation resistance is difficult because the properties of the insulation are generally predictable only within a wide range. The equations presented below are therefore quite dependent upon an accurate knowledge of insulation power factor.

For single-conductor and three-conductor shielded cables,

$$r_1 = r_2 = r_0 = \frac{1.79G}{f \cdot k \cdot \cos \phi} \cdot 10^8 \text{ ohms per phase per mile.} \quad (48)$$

For three-conductor belted cables,

$$r_1 = r_2 = \frac{0.597G_1}{f \cdot k \cdot \cos \phi} \cdot 10^8 \text{ ohms per phase per mile.} \quad (49)$$

$$r_0 = \frac{1.79G_0}{f \cdot k \cdot \cos \phi} \cdot 10^8 \text{ ohms per phase per mile.} \quad (50)$$

In these equations,

r_1 , r_2 , and r_0 are positive-, negative-, and zero-sequence shunt resistances.

k = dielectric constant (see Table 4).

$\cos \phi$ = power factor of insulation, in per unit.

In Table 5 are listed maximum values of insulation power factor, taken from specifications of the Association of Edison Illuminating Companies¹⁶. These standard values will very probably be several times larger than actual measured power factors on new cables.

TABLE 4—DIELECTRIC CONSTANTS OF CABLE INSULATION

Insulation	Range of k	Typical k
Solid Paper	3.0–4.0	3.7
Oil-Filled	3.0–4.0	3.5
Gas-Filled	3.0–4.0	3.7
Varnished Cambric	4.0–6.0	5.0
Rubber	4.0–9.0	6.0

TABLE 5—MAXIMUM POWER FACTORS* OF CABLE INSULATION

Temperature of Cable (Deg. C.)	Solid Paper	Oil-Filled (low-pressure)	Gas-Filled (low-pressure)
25 to 60	0.009	0.0060	0.009
70	0.015	0.0075	0.013
80	0.021	0.0090	0.018
85	0.025	0.0097	0.022
90	0.030	0.0105	0.027

*The power factor of new cable is usually below these values by a wide margin.¹⁶

II. TABLES OF ELECTRICAL CHARACTERISTICS

The 60-cycle electrical characteristics of the most usual sizes and voltage classes of paper insulated cable are contained in Tables 6 through 11. In each case the positive-, negative-, and zero-sequence resistances and reactances are tabulated, or else constants are given from which these quantities can be calculated. Also, included in these tables are other characteristics useful in cable work, such as typical weights per 1000 feet, sheath thicknesses and resistances, conductor diameters and GMR's, and the type of conductors normally used in any particular cable.

In each of these tables the electrical characteristics have been calculated by the equations and curves presented in the foregoing pages. Where sector-shaped conductors are used, some approximations are necessary as pointed out previously. In Table 6 the positive- and negative-sequence reactance for sectored cables has arbitrarily been taken 7.5 percent less than that of an equivalent round-conductor cable, in accordance with Dr. Simmons' recommendations. The equivalent GMR of three conductors in sectored cables is necessarily an approximation because the GMR of one sector cannot be determined accurately. This condition arises since the shape of sectors varies and a rigorous calculation is not justified. The variation in sector shapes probably is greater than any error present in the approximation given in the tables. The reactances calculated from these approximate GMR's are sufficiently accurate for all practical calculations.

Table 7 for shielded cables is similar in form to Table 6 and where sectored cables are listed the same approximations in GMR and reactance apply. Table 8 for three-conductor oil-filled cables is similar to both Tables 6 and 7 and the same considerations apply.

In these tables for three-conductor cables, the zero-sequence characteristics are calculated for the case of all return current in the sheath and none in the ground. As pointed out in the discussion of zero-sequence impedance, this is usually sufficiently accurate because of the indefinite nature of the ground return circuit. Where ground must be considered or where there are paralleled three-phase circuits, the impedance must be calculated as illustrated in the examples given.

From the quantities given in these tables of three-conductor cables, the overall diameter of any particular cable can be calculated.

$$D = 2.155(d + 2T) + 2(t + L) \quad (51)$$

TABLE 6—60-CYCLE CHARACTERISTICS OF THREE-CONDUCTOR BELTED PAPER-INSULATED CABLES
Grounded Neutral Service

Voltage Class	Insulation Thickness Mils		Circular Mils or AWG (B. & S.)	Type of (4) Conductor	Weight per 1000 Feet	Diameter or Sector Depth (5) inches	Resistance, Ohms Per Mile (1)	GMR of One Conductor—Inches (2)	POSITIVE & NEGATIVE—SEQ.		GMR—Three Conductors	ZERO—SEQUENCE			SHEATH		
	Conductor	Belt							Series Reactance Ohms per Mile (3)	Shunt Capacitive Reactance Ohms per Mile (3)		Series Resistance Ohms per Mile (4)	Series Reactance Ohms per Mile (4)	Shunt Capacitive Reactance Ohms per Mile (4)	Thickness Mils	Resistance, Ohms per Mile at 50°C	
1 Kv	60	35	6	SR	1 500	0.184	2.50	0.067	0.185	6300	0.184	10.66	0.315	11 600	85	2.69	
	60	35	4	SR	1 910	0.232	1.58	0.084	0.175	5400	0.218	8.39	0.293	10 200	90	2.27	
	60	35	2	SR	2 390	0.292	0.987	0.106	0.165	4700	0.262	6.99	0.273	9 000	90	2.00	
	60	35	1	SR	2 820	0.332	0.786	0.126	0.155	4300	0.295	6.07	0.256	8 400	95	1.76	
	60	35	0	SR	3 210	0.373	0.622	0.142	0.152	4000	0.326	5.54	0.246	7 900	95	1.64	
	60	35	00	CS	3 160	0.323	0.495	0.151	0.138	2800	0.290	5.96	0.250	5 400	95	1.82	
	60	35	000	CS	3 650	0.364	0.392	0.171	0.134	2300	0.320	5.46	0.241	4 500	95	1.69	
	60	35	0000	CS	4 390	0.417	0.310	0.191	0.131	2000	0.355	4.72	0.237	4 000	100	1.47	
	60	35	250 000	CS	4 900	0.455	0.263	0.210	0.129	1800	0.387	4.46	0.224	3 600	100	1.40	
	60	35	300 000	CS	5 660	0.497	0.220	0.230	0.128	1700	0.415	3.97	0.221	3 400	105	1.25	
	60	35	350 000	CS	6 310	0.539	0.190	0.249	0.126	1500	0.440	3.73	0.216	3 100	105	1.18	
	60	35	400 000	CS	7 080	0.572	0.166	0.265	0.124	1500	0.467	3.41	0.214	2 900	110	1.08	
	60	35	500 000	CS	8 310	0.642	0.134	0.297	0.123	1300	0.517	3.11	0.208	2 600	110	0.993	
	65	40	600 000	CS	9 800	0.700	0.113	0.327	0.122	1200	0.567	2.74	0.197	2 400	115	0.877	
	65	40	750 000	CS	11 800	0.780	0.091	0.366	0.121	1100	0.623	2.40	0.194	2 100	120	0.771	
	3 Kv	70	40	6	SR	1 680	0.184	2.50	0.067	0.192	6700	0.192	9.67	0.322	12 500	90	2.39
		70	40	4	SR	2 030	0.232	1.58	0.084	0.181	5800	0.227	8.06	0.298	11 200	90	2.16
		70	40	2	SR	2 600	0.292	0.987	0.106	0.171	5100	0.271	6.39	0.278	9 800	95	1.80
70		40	1	SR	2 930	0.332	0.786	0.126	0.161	4700	0.304	5.83	0.263	9 200	95	1.68	
70		40	0	SR	3 440	0.373	0.622	0.142	0.156	4400	0.335	5.06	0.256	8 600	100	1.48	
70		40	00	CS	3 300	0.323	0.495	0.151	0.142	3500	0.297	5.69	0.259	6 700	95	1.73	
70		40	000	CS	3 890	0.364	0.392	0.171	0.138	2700	0.329	5.28	0.246	5 100	95	1.63	
70		40	0000	CS	4 530	0.417	0.310	0.191	0.135	2400	0.367	4.57	0.237	4 600	100	1.42	
70		40	250 000	CS	5 160	0.455	0.263	0.210	0.132	2100	0.396	4.07	0.231	4 200	105	1.27	
70		40	300 000	CS	5 810	0.497	0.220	0.230	0.130	1900	0.424	3.82	0.228	3 800	105	1.20	
70		40	350 000	CS	6 470	0.539	0.190	0.249	0.129	1800	0.455	3.61	0.219	3 700	105	1.14	
70		40	400 000	CS	7 240	0.572	0.166	0.265	0.128	1700	0.478	3.32	0.218	3 400	110	1.05	
70		40	500 000	CS	8 660	0.642	0.134	0.297	0.126	1500	0.527	2.89	0.214	3 000	115	0.918	
75		40	600 000	CS	9 910	0.700	0.113	0.327	0.125	1400	0.577	2.68	0.210	2 800	115	0.855	
75		40	750 000	CS	11 920	0.780	0.091	0.366	0.123	1300	0.633	2.37	0.204	2 500	120	0.758	
5 Kv		105	55	6	SR	2 150	0.184	2.50	0.067	0.215	8500	0.218	8.14	0.342	15 000	95	1.88
		100	55	4	SR	2 470	0.232	1.58	0.084	0.199	7600	0.250	6.86	0.317	13 600	95	1.76
		95	50	2	SR	2 900	0.292	0.987	0.106	0.184	6100	0.291	5.88	0.290	11 300	95	1.63
	90	45	1	SR	3 280	0.332	0.786	0.126	0.171	5400	0.321	5.23	0.270	10 200	100	1.48	
	90	45	0	SR	3 660	0.373	0.622	0.142	0.165	5000	0.352	4.79	0.259	9 600	100	1.39	
	85	45	00	CS	3 480	0.323	0.495	0.151	0.148	3600	0.312	5.42	0.263	9 300	95	1.64	
	85	45	000	CS	4 080	0.364	0.392	0.171	0.143	3200	0.343	4.74	0.254	6 700	100	1.45	
	85	45	0000	CS	4 720	0.417	0.310	0.191	0.141	2800	0.380	4.33	0.245	8 300	100	1.34	
	85	45	250 000	CS	5 370	0.455	0.263	0.210	0.138	2600	0.410	3.89	0.237	7 800	105	1.21	
	85	45	300 000	CS	6 050	0.497	0.220	0.230	0.135	2400	0.438	3.67	0.231	7 400	105	1.15	
	85	45	350 000	CS	6 830	0.539	0.190	0.249	0.133	2200	0.470	3.31	0.225	7 000	110	1.04	
	85	45	400 000	CS	7 480	0.572	0.166	0.265	0.131	2000	0.493	3.17	0.221	6 700	110	1.00	
	85	45	500 000	CS	8 890	0.642	0.134	0.297	0.129	1800	0.542	2.79	0.216	6 200	115	0.885	
	85	45	600 000	CS	10 300	0.700	0.113	0.327	0.128	1600	0.587	2.51	0.210	5 800	120	0.798	
	85	45	750 000	CS	12 340	0.780	0.091	0.366	0.125	1500	0.643	2.21	0.206	5 400	125	0.707	
	8 Kv	130	65	6	SR	2 450	0.184	2.50	0.067	0.230	9600	0.236	7.57	0.353	16 300	95	1.69
		125	65	4	SR	2 900	0.232	1.58	0.084	0.212	8300	0.269	6.08	0.329	14 500	100	1.50
		115	60	2	SR	3 280	0.292	0.987	0.106	0.193	6800	0.307	5.25	0.302	12 500	100	1.42
110		55	1	SR	3 560	0.332	0.786	0.126	0.179	6100	0.338	4.90	0.280	11 400	100	1.37	
110		55	0	SR	4 090	0.373	0.622	0.142	0.174	5700	0.368	4.31	0.272	10 700	105	1.23	
105		55	00	CS	3 870	0.323	0.495	0.151	0.156	4300	0.330	4.79	0.273	8 300	100	1.43	
105		55	000	CS	4 390	0.364	0.392	0.171	0.151	3800	0.362	4.41	0.263	7 400	100	1.34	
105		55	0000	CS	5 150	0.417	0.310	0.191	0.147	3500	0.399	3.88	0.254	6 600	105	1.19	
105		55	250 000	CS	5 830	0.455	0.263	0.210	0.144	3200	0.428	3.50	0.246	6 200	110	1.08	
105		55	300 000	CS	6 500	0.497	0.220	0.230	0.141	2900	0.458	3.31	0.239	5 600	110	1.03	
105		55	350 000	CS	7 160	0.539	0.190	0.249	0.139	2700	0.489	3.12	0.233	5 200	110	0.978	
105		55	400 000	CS	7 980	0.572	0.166	0.265	0.137	2500	0.513	2.86	0.230	4 900	115	0.899	
105		55	500 000	CS	9 430	0.642	0.134	0.297	0.135	2200	0.563	2.53	0.224	4 300	120	0.800	
105		55	600 000	CS	10 680	0.700	0.113	0.327	0.132	2000	0.606	2.39	0.218	3 900	120	0.758	
105		55	750 000	CS	12 740	0.780	0.091	0.366	0.129	1800	0.663	2.11	0.211	3 500	125	0.673	
15 Kv		170	85	2	SR	4 350	0.292	0.987	0.106	0.217	8600	0.349	4.20	0.323	15 000	110	1.07
		165	80	1	SR	4 640	0.332	0.786	0.126	0.202	7800	0.381	3.88	0.305	13 800	110	1.03
		160	75	0	SR	4 990	0.373	0.622	0.142	0.193	7100	0.409	3.62	0.288	12 800	110	1.00
	155	75	00	SR	5 600	0.419	0.495	0.159	0.185	6500	0.439	3.25	0.280	12 000	115	0.918	
	155	75	000	SR	6 230	0.470	0.392	0.178	0.180	6000	0.476	2.99	0.272	11 300	115	0.867	
	155	75	0000	SR	7 180	0.528	0.310	0.200	0.174	5600	0.520	2.64	0.263	10 600	120	0.778	
	155	75	250 000	SR	7 840	0.575	0.263	0.218	0.168	5300	0.555	2.50	0.256	10 200	120	0.744	
	155	75	300 000	CS	7 480	0.497	0.220	0.230	0.155	5400	0.507	2.79	0.254	7 900	115	0.855	
	155	75	350 000	CS	8 340	0.539	0.190	0.249	0.152	5100	0.536	2.54	0.250	7 200	120	0.784	
	155	75	400 000	CS	9 030	0.572	0.166	0.265	0.149	4900	0.561	2.44	0.245	6 900	120	0.758	

TABLE 7—60-CYCLE CHARACTERISTICS OF THREE-CONDUCTOR SHIELDED PAPER-INSULATED CABLES
Grounded Neutral Service

Voltage Class	Insulation Thickness Mils	Circular Mils or AWG (B. & S.)	Type of Conductor (†)	Weight per 1000 Feet	Diameter or Sector Depth (‡) inches	Resistance—Ohms per Mile (‡)	GMR of one Conductor (‡) inches	POSITIVE & NEGATIVE SEQUENCE		GMR—Three Conductors	ZERO—SEQUENCE			SHEATH	
								Series Reactance Ohms per Mile	Shunt-Capacitive Reactance—Ohms per Mile (¶)		Series Reactance Ohms per Mile (¶)	Series Reactance Ohms per Mile (¶)	Shunt-Capacitive Reactance—Ohms per Mile (¶)	Thickness Mils	Resistance Ohms per Mile at 50°C
15 Kv	205	4	SR	3 860	0.232	1.58	0.084	0.248	8200	0.328	5.15	0.325	8200	105	1.19
	190	2	SR	4 260	0.292	0.987	0.106	0.226	6700	0.365	4.44	0.298	6700	105	1.15
	185	1	SR	4 740	0.332	0.786	0.126	0.210	6000	0.398	3.91	0.285	6000	110	1.04
	180	0	SR	5 090	0.373	0.622	0.141	0.201	5400	0.425	3.65	0.275	5400	110	1.01
	175	00	CS	4 790	0.323	0.495	0.151	0.178	5200	0.397	3.95	0.268	5200	105	1.15
	175	000	CS	5 510	0.364	0.392	0.171	0.170	4800	0.432	3.48	0.256	4800	110	1.03
	175	0000	CS	6 180	0.417	0.310	0.191	0.166	4400	0.468	3.24	0.249	4400	110	0.975
	175	250 000	CS	6 910	0.455	0.263	0.210	0.158	4100	0.498	2.95	0.243	4100	115	0.897
	175	300 000	CS	7 610	0.497	0.220	0.230	0.156	3800	0.530	2.80	0.237	3800	115	0.860
	175	350 000	CS	8 480	0.539	0.190	0.249	0.153	3600	0.561	2.53	0.233	3600	120	0.783
	175	400 000	CS	9 170	0.572	0.166	0.265	0.151	3400	0.585	2.45	0.228	3400	120	0.761
	175	500 000	CS	10 710	0.642	0.134	0.297	0.146	3100	0.636	2.19	0.222	3100	125	0.684
175	600 000	CS	12 230	0.700	0.113	0.327	0.143	2900	0.681	1.98	0.215	2900	130	0.623	
175	750 000	CS	14 380	0.780	0.091	0.366	0.139	2600	0.737	1.78	0.211	2600	135	0.562	
23 Kv	265	2	SR	5 590	0.292	0.987	0.106	0.250	8300	0.418	3.60	0.317	8300	115	0.870
	250	1	SR	5 860	0.332	0.786	0.126	0.232	7500	0.450	3.26	0.298	7500	115	0.851
	250	0	SR	6 440	0.373	0.622	0.141	0.222	6800	0.477	2.99	0.290	6800	120	0.788
	240	00	CS	6 060	0.323	0.495	0.151	0.196	6600	0.446	3.16	0.285	6600	115	0.890
	240	000	CS	6 620	0.364	0.392	0.171	0.188	6000	0.480	2.95	0.285	6000	115	0.851
	240	0000	CS	7 480	0.410	0.310	0.191	0.181	5600	0.515	2.64	0.268	5600	120	0.775
	240	250 000	CS	8 070	0.447	0.263	0.210	0.177	5200	0.545	2.50	0.261	5200	120	0.747
	240	300 000	CS	8 990	0.490	0.220	0.230	0.171	4900	0.579	2.29	0.252	4900	125	0.690
	240	350 000	CS	9 720	0.532	0.190	0.249	0.167	4600	0.610	2.10	0.249	4600	125	0.665
	240	400 000	CS	10 650	0.566	0.166	0.265	0.165	4400	0.633	2.03	0.246	4400	130	0.620
	240	500 000	CS	12 280	0.635	0.134	0.297	0.159	3900	0.687	1.82	0.237	3900	135	0.562
	240	600 000	CS	13 610	0.690	0.113	0.327	0.154	3700	0.730	1.73	0.230	3700	135	0.540
240	750 000	CS	15 830	0.767	0.091	0.366	0.151	3400	0.787	1.56	0.225	3400	140	0.488	
35 Kv	355	0	SR	8 520	0.288	0.622	0.141	0.239	9900	0.523	2.40	0.330	9900	130	0.594
	345	00	SR	9 180	0.323	0.495	0.159	0.226	9100	0.548	2.17	0.322	9100	135	0.559
	345	000	SR	9 900	0.364	0.392	0.178	0.217	8500	0.585	2.01	0.312	8500	135	0.538
	345	0000	CS	9 830	0.410	0.310	0.191	0.204	7200	0.594	2.00	0.290	7200	135	0.563
	345	250 000	CS	10 470	0.447	0.263	0.210	0.197	6800	0.628	1.90	0.280	6800	135	0.545
	345	300 000	CS	11 290	0.490	0.220	0.230	0.191	6400	0.663	1.80	0.273	6400	135	0.527
	345	350 000	CS	12 280	0.532	0.190	0.249	0.187	6000	0.693	1.66	0.270	6000	140	0.491
	345	400 000	CS	13 030	0.566	0.166	0.265	0.183	5700	0.721	1.61	0.265	5700	140	0.480
	345	500 000	CS	14 760	0.635	0.134	0.297	0.177	5200	0.773	1.46	0.257	5200	145	0.441
	345	600 000	CS	16 420	0.690	0.113	0.327	0.171	4900	0.819	1.35	0.248	4900	150	0.412
	345	750 000	CS	18 860	0.767	0.091	0.366	0.165	4500	0.879	1.22	0.243	4500	155	0.377

†A-c resistance based on 100% conductivity at 65°C, including 2% allowance for stranding.
‡GMR of sector-shaped conductors is an approximate figure close enough for most practical applications.
§For dielectric constant=3.7.
¶Based on all return current in the sheath; none in ground.
‡See Fig. 7.
*The following symbols are used to designate conductor types: SR—Stranded Round; CS—Compact Sector.

in which, according to Fig. 6,

- D = outside diameter in inches.
- d = diameter of individual conductor in inches.
- T = conductor insulation thickness in inches.
- t = belt insulation thickness in inches (when present).
- L = lead sheath thickness in inches.

This equation refers to cables with round conductors. For sectored cables there is no exact rule, but a close approximation can be obtained by using an equivalent cable with round conductors and calculating the diameter D by Eq. (11), and then subtracting 0.3 to 0.4 times the round conductor diameter d , depending upon the shape of the sector.

A set of calculated constants is given in Table 10 for single-conductor cables, from which the positive-, negative- and zero-sequence characteristics can be quickly determined by using the equations given at the foot of the tabulation. These equations are derived directly from

those given for the calculation of sequence impedances in the sections under Electrical Characteristics. Since

$$x_s = 0.2794 \frac{f}{60} \log_{10} \frac{12}{GMR_{1s}} \text{ ohms per phase per mile} \quad (12)$$

$$x_s = 0.2794 \frac{f}{60} \log_{10} \frac{24}{r_o + r_i} \text{ ohms per phase per mile} \quad (22)$$

$$x_d = 0.2794 \frac{f}{60} \log_{10} \frac{S}{12} \text{ ohms per phase per mile} \quad (13)$$

and r_c and r_s are conductor and sheath resistances respectively, the derivation of the equations given with Table 10 becomes evident. Table 12 gives the one other quantity, x_d , necessary for the use of Table 10. These reactance spacing factors are tabulated for equivalent cable spacings

TABLE 8—60-CYCLE CHARACTERISTICS OF THREE-CONDUCTOR OIL-FILLED PAPER-INSULATED CABLES
Grounded Neutral Service

Voltage Class	Insulation Thickness Mils	Circular Mills or AWG (B. & S.)	Type of Conductor (°)	Weight per 1000 Feet	Diameter or Sector Depth (°)—inches	Resistance-Ohms Per Mile (¹)	GMR of One Conductor (²)—inches	POSITIVE & NEGATIVE SEQ.		GMR—Three Conductors	ZERO—SEQUENCE			SHEATH	
								Series Reactance Ohms Per Mile	Shunt Capacitive Reactance-Ohms Per Mile (³)		Series Resistance Ohms Per Mile (⁴)	Series Reactance Ohms Per Mile (⁴)	Shunt Capacitive Reactance-Ohms Per Mile (⁴)	Thickness Mils	Resistance-Ohms Per Mile at 50°C
35 Kv	190	00	CS	5 590	0.323	0.495	0.151	0.185	6030	0.406	3.56	0.265	6030	115	1.02
		000	CS	6 150	0.364	0.392	0.171	0.178	5480	0.439	3.30	0.256	5480	115	0.970
		0000	CS	6 860	0.417	0.310	0.191	0.172	4840	0.478	3.06	0.243	4840	115	0.918
		250 000	CS	7 680	0.455	0.263	0.210	0.168	4570	0.508	2.72	0.238	4570	125	0.820
		300 000	CS	9 090	0.497	0.220	0.230	0.164	4200	0.539	2.58	0.232	4200	125	0.788
		350 000	CS	9 180	0.539	0.190	0.249	0.160	3900	0.570	2.44	0.227	3900	125	0.752
		400 000	CS	9 900	0.572	0.166	0.265	0.157	3690	0.595	2.35	0.223	3690	125	0.720
		500 000	CS	11 550	0.642	0.134	0.297	0.153	3400	0.646	2.04	0.217	3400	135	0.636
		600 000	CS	12 900	0.700	0.113	0.327	0.150	3200	0.691	1.94	0.210	3200	135	0.608
		750 000	CS	15 660	0.780	0.091	0.366	0.148	3070	0.763	1.73	0.202	3070	140	0.548
46 Kv	225	00	CS	6 360	0.323	0.495	0.151	0.195	6700	0.436	3.28	0.272	6700	115	0.928
		000	CS	6 940	0.364	0.392	0.171	0.188	6100	0.468	2.87	0.265	6100	125	0.826
		0000	CS	7 660	0.410	0.310	0.191	0.180	5520	0.503	2.67	0.256	5520	125	0.788
		250 000	CS	8 280	0.447	0.263	0.210	0.177	5180	0.533	2.55	0.247	5180	125	0.761
		300 000	CS	9 690	0.490	0.220	0.230	0.172	4820	0.566	2.41	0.241	4820	125	0.729
		350 000	CS	10 100	0.532	0.190	0.249	0.168	4490	0.596	2.16	0.237	4490	135	0.658
		400 000	CS	10 820	0.566	0.166	0.265	0.165	4220	0.623	2.08	0.232	4220	135	0.639
		500 000	CS	12 220	0.635	0.134	0.297	0.160	3870	0.672	1.94	0.226	3870	135	0.603
		600 000	CS	13 930	0.690	0.113	0.327	0.156	3670	0.718	1.74	0.219	3670	140	0.542
		750 000	CS	16 040	0.767	0.091	0.366	0.151	3350	0.773	1.62	0.213	3350	140	0.510
69 Kv	315	00	CR	8 240	0.376	0.495	0.147	0.234	8330	0.532	2.41	0.290	8330	135	0.639
		000	CS	8 830	0.364	0.392	0.171	0.208	7560	0.538	2.32	0.284	7560	135	0.642
		0000	CS	9 660	0.410	0.310	0.191	0.200	6840	0.575	2.16	0.274	6840	135	0.618
		250 000	CS	10 330	0.447	0.263	0.210	0.195	6500	0.607	2.06	0.266	6500	135	0.597
		300 000	CS	11 540	0.490	0.220	0.230	0.190	6030	0.640	1.85	0.260	6030	140	0.543
		350 000	CS	12 230	0.532	0.190	0.249	0.185	5700	0.672	1.77	0.254	5700	140	0.527
		400 000	CS	13 040	0.566	0.166	0.265	0.181	5430	0.700	1.55	0.248	5430	140	0.513
		500 000	CS	14 880	0.635	0.134	0.297	0.176	5050	0.750	1.51	0.242	5050	150	0.460
		600 000	CS	16 320	0.690	0.113	0.327	0.171	4740	0.797	1.44	0.235	4740	150	0.442
		750 000	CS	18 980	0.767	0.091	0.366	0.165	4360	0.854	1.29	0.230	4360	155	0.399

¹A-c resistance based on 100% conductivity at 65°C. including 2% allowance for stranding.
 ²GMR of sector-shaped conductors is an approximate figure close enough for most practical applications.
 ³For dielectric constant=3.5.
 ⁴Based on all return current in sheath; none in ground.
 ⁵See Fig. 7.
 ⁶The following symbols are used to designate the cable types: CR—Compact Round; CS—Compact Sector.

from 0.5 to 36.0 inches, which should cover the range met in practice. For all spacings less than 12 inches, x_d is negative.

The constants calculated in this manner apply to one three-phase circuit of single-conductor lead-sheath cables, assuming all zero-sequence return current to be in the sheaths, none in the ground.

The 60-cycle characteristics of single-conductor oil-filled cables are given in Table 11. This table is similar in form to Table 10 and the impedance characteristics are determined in precisely the same way. Here again the sequence constants apply to one three-phase circuit of three cables with zero-sequence return current assumed to be all in the cable sheaths. Single-conductor oil-filled cables have hollow conductors (the oil channel forms the core), consequently Table 11 includes cables of the two most common inside diameters, 0.5 and 0.69 inches.

In each of the tabulations, the voltage class listed in the first column refers specifically to grounded-neutral operation. Frequently cable systems are operated with other than a solidly grounded neutral. In low-voltage cables the

same insulation thickness is used for both grounded and ungrounded operation, but in cables rated 7000 volts and above, a greater thickness of insulation is recommended for a given voltage class when cable is operated with an ungrounded neutral. A good approximation of the electrical characteristics of these higher voltage cables when operated with other than a solidly grounded neutral, can be had by referring in each specific case to the next higher voltage class listed in the tables.

The constants of several typical cables calculated by the methods outlined are listed in Table 13. These typical cases are included to be used as a check on the general magnitude of cable constants when making calculations for a specific case. Representative sizes and types of cable have been chosen to cover as many types of calculation as possible.

III. TABLES OF CURRENT CARRYING CAPACITY

One of the most common problems in cable calculations is that of determining the maximum permissible amperes

TABLE 9—60-CYCLE CHARACTERISTICS OF THREE-CONDUCTOR GAS-FILLED PAPER-INSULATED CABLES (SHIELDED TYPE)

Grounded Neutral Service

Voltage Class	Insulation Thickness Mils	Circular Mils or AWG (B. & B.)	Type of Conductor (†)	Weight Per 1000 Feet	Diameter or Sector Depth (‡)—inches	Resistance-Ohms Per Mile (¶)	GMR of One Conductor (‡)—inches	POSITIVE & NEGATIVE SEQ.		GMR—Three Conductors	ZERO-SEQUENCE			SHEATH	
								Series Reactance Ohms Per Mile	Shunt Capacitive Reactance-Ohms Per Mile (‡)		Series Resistance Ohms Per Mile (‡)	Series Reactance Ohms Per Mile (‡)	Shunt Capacitive Reactance-Ohms Per Mile (‡)	Thickness Mils	Resistance-Ohms Per Mile at 50°C
15 Kv	130	2	SR	3 800	0.292	0.987	0.106	0.197	5100	0.321	4.86	0.289	5100	110	1.29
	130	1	SR	4 320	0.332	0.786	0.126	0.189	4600	0.354	4.42	0.274	4600	110	1.21
	130	0	CS	4 010	0.288	0.622	0.135	0.172	4500	0.326	4.52	0.279	4500	110	1.30
	130	00	CS	4 440	0.323	0.495	0.151	0.165	4200	0.355	4.34	0.267	4200	110	1.28
	130	000	CS	4 970	0.364	0.392	0.171	0.158	3800	0.392	3.90	0.245	3800	110	1.17
	130	0000	CS	5 620	0.417	0.310	0.191	0.158	3500	0.437	3.58	0.234	3500	110	1.09
	130	250 000	CS	6 180	0.455	0.263	0.210	0.153	3200	0.462	3.41	0.230	3200	110	1.05
	130	350 000	CS	7 530	0.539	0.190	0.249	0.146	2800	0.521	3.05	0.222	2800	110	0.953
	130	500 000	CS	9 540	0.642	0.134	0.297	0.141	2400	0.600	2.70	0.210	2400	110	0.854
	130	750 000	CS	12 900	0.780	0.091	0.366	0.137	2200	0.715	2.21	0.198	2200	115	0.707
	150	1 000 000	CS	16 450	0.900	0.070	0.430	0.134	2000	0.810	1.80	0.193	2000	125	0.578
23 Kv	200	2	SR	4 670	0.292	0.987	0.106	0.224	6900	0.376	4.17	0.302	6900	110	1.06
		1	SR	5 120	0.332	0.786	0.126	0.215	6300	0.410	3.82	0.286	6300	110	1.01
		0	CR	5 300	0.288	0.622	0.131	0.211	6200	0.398	3.62	0.302	6200	110	1.00
		00	CS	5 360	0.323	0.495	0.151	0.188	5800	0.412	3.56	0.281	5800	110	1.02
		000	CS	5 910	0.364	0.392	0.171	0.178	5300	0.445	3.31	0.271	5300	110	0.971
		0000	CS	6 570	0.417	0.310	0.191	0.175	4800	0.488	3.08	0.258	4800	110	0.922
		250 000	CS	7 160	0.455	0.263	0.210	0.171	4500	0.520	2.92	0.249	4500	110	0.885
		350 000	CS	8 540	0.539	0.190	0.249	0.163	4000	0.575	2.64	0.240	4000	110	0.816
		500 000	CS	10 750	0.642	0.134	0.297	0.155	3500	0.655	2.36	0.230	3500	110	0.741
		750 000	CS	14 650	0.780	0.091	0.466	0.147	2900	0.760	1.84	0.218	2900	125	0.582
	1 000 000	CS	18 560	0.900	0.070	0.430	0.144	2600	0.850	1.49	0.210	2600	140	0.473	
35 Kv	310	0	CR	6 900	0.288	0.622	0.131	0.242	8400	0.477	3.00	0.320	8400	110	0.794
		00	CR	7 300	0.323	0.495	0.147	0.233	7900	0.509	2.69	0.310	7900	110	0.763
		000	CR	8 200	0.364	0.392	0.165	0.222	7300	0.545	2.58	0.284	7300	115	0.730
		0000	CS	8 660	0.410	0.310	0.191	0.201	6700	0.570	2.43	0.281	6700	115	0.707
		250 000	CS	9 380	0.447	0.263	0.210	0.195	6300	0.604	2.32	0.270	6300	115	0.685
		350 000	CS	11 200	0.532	0.190	0.249	0.185	5600	0.665	1.95	0.264	5600	125	0.587
		500 000	CS	12 790	0.635	0.134	0.297	0.175	4800	0.745	1.63	0.251	4800	135	0.500
		750 000	CS	18 190	0.767	0.091	0.366	0.165	4200	0.847	1.32	0.238	4200	150	0.409
		1 000 000	CS	22 100	0.898	0.070	0.430	0.158	3700	0.930	1.13	0.234	3700	160	0.353

1A-c resistance based on 100% conductivity at 65°C. including 2% allowance for stranding.
 *GMR of sector-shaped conductors is an approximate figure close enough for most practical applications.
 †For dielectric constant=3.7.
 ‡Based on all return current in sheath; none in ground.
 §Sec Fig. 7.
 ¶The following symbols are used to designate conductor types: SR—Stranded Round; CR—Compact Round; CS—Compact Sector.

per conductor for any given cable. The limiting factor in cable applications is not always the maximum permissible insulation temperature. Sometimes regulation, efficiency, economy, etc., may dictate the maximum permissible amperes. However because temperature rise is most often the controlling factor, the calculations of current-carrying capacity are usually based upon this limitation.

In Tables 14 through 19 earth temperature is assumed to be uniform at 20 degrees Centigrade. These tables were taken from a publication¹⁶ of the Insulated Power Cable Engineers Association and give maximum allowable amperes per conductor for representative cable types. Corrections for earth temperatures other than 20 degrees Centigrade are given within the tables.

Special conditions may make it advisable to calculate a cable temperature problem in detail,^{10,11} taking into account variable loading, "hot spots" along the cable route, and other factors not contemplated in making up the tabulated information.

Approximations can also be obtained for the current-carrying capacities of other types of insulation by applying

multipliers to the tables presented for paper-insulated cables. The value for varnished cambric-insulated cables can be obtained by multiplying the value given in the tables for paper insulation by 0.91, the resulting figure being accurate to within five percent of the calculated value. Similarly, carrying capacities for rubber insulation can be determined with the same degree of accuracy by applying a factor of 0.85 to the figure given for an equivalent paper-insulated cable. For special heat-resisting rubber this factor becomes 0.95.

Circuits are frequently installed with each duct containing three cables. The current capacity of these circuits will be less than that tabulated here for one cable per duct, but will be somewhat higher than the capacity of an equivalent shielded three-conductor cable of the same conductor size and voltage rating.

The number of overhead power cables is a small percentage of the number in ducts, and for this reason space does not permit inclusion of loading tables for cables in air. Unfortunately there is no simple correction factor or curve that can be used to translate the figure for cables in ducts

TABLE 10—60-CYCLE CHARACTERISTICS OF SINGLE-CONDUCTOR CONCENTRIC-STRAND PAPER-INSULATED CABLES
Grounded Neutral Service

Voltage Class	Insulation Thickness Mils	Circular Mills or AWG (B & S)	Weight Per 1000 Feet	Diameter of Conductor—inches	GMR of One Conductor ¹ —inches	Reactance at 12 Inches—Ohms Per Phase Per Mile	Reactance of Sheath—Ohms Per Phase Per Mile	Resistance of One Conductor—Ohms Per Phase Per Mile ²	Resistance of Sheath —Ohms Per Phase Per Mile at 50°C	Shunt Capacitive Reactance—Ohms Per Phase Per Mile ³	Lead Sheath Thickness—Mils	Voltage Class										
												Insulation thickness Mils	Circular Mills or AWG (B & S)	Weight Per 1000 Feet	Diameter of Conductor—inches	GMR of One Conductor ¹ inches	Reactance at 12 inches—Ohms per Phase per Mile	Reactance of Sheath —Ohms per Phase	Resistance of One Conductor—Ohms per Phase per Mile ²	Resistance of Sheath —Ohms per phase per Mile at 50°C	Shunt-Capacitive React- ance Ohms per phase per Mile ³	Lead Sheath Thickness—Mils
1 Kv	60	6	560	0.184	0.067	0.628	0.489	2.50	6.20	4040	75	220	4	1340	0.232	0.084	0.602	0.412	1.58	2.91	8560	85
	60	4	670	0.232	0.084	0.602	0.475	1.58	5.56	3360	75	215	2	1500	0.292	0.106	0.573	0.406	0.987	2.74	7270	85
	60	2	880	0.292	0.106	0.573	0.458	0.987	4.55	2760	80	210	1	1610	0.332	0.126	0.552	0.400	0.786	2.64	6580	86
	60	1	990	0.332	0.126	0.552	0.450	0.786	4.25	2490	80	200	0	1710	0.373	0.141	0.539	0.397	0.622	2.59	5880	85
	60	0	1110	0.373	0.141	0.539	0.442	0.622	3.61	2250	80	195	00	1940	0.418	0.159	0.524	0.391	0.495	2.32	5290	90
	60	00	1270	0.418	0.159	0.524	0.434	0.495	3.34	2040	80	185	000	2100	0.470	0.178	0.512	0.386	0.392	2.24	4680	90
	60	000	1510	0.470	0.178	0.512	0.425	0.392	3.23	1840	85	180	0000	2300	0.528	0.200	0.496	0.380	0.310	2.14	4200	90
	60	0000	1740	0.528	0.200	0.496	0.414	0.310	2.98	1650	85	175	250 000	2500	0.575	0.221	0.484	0.377	0.263	2.06	3820	90
	60	250 000	1930	0.575	0.221	0.484	0.408	0.263	2.81	1530	85	175	350 000	3110	0.681	0.262	0.464	0.366	0.190	1.98	3340	95
	60	350 000	2490	0.681	0.262	0.464	0.392	0.190	2.31	1300	90	175	500 000	3940	0.814	0.313	0.442	0.352	0.134	1.51	2870	100
	60	500 000	3180	0.814	0.313	0.442	0.378	0.134	2.06	1090	90	175	750 000	5240	0.998	0.385	0.417	0.336	0.091	1.26	2420	105
	60	750 000	4380	0.998	0.385	0.417	0.358	0.091	1.65	885	95	175	1 000 000	6350	1.152	0.445	0.400	0.325	0.070	1.15	2130	105
60	1 000 000	5560	1.152	0.445	0.400	0.344	0.070	1.40	800	100	175	1 500 000	8810	1.412	0.546	0.374	0.305	0.050	0.90	1790	115	
60	1 500 000	8000	1.412	0.543	0.374	0.319	0.050	1.05	645	110	175	2 000 000	11080	1.632	0.633	0.356	0.294	0.041	0.772	1570	120	
60	2 000 000	10190	1.632	0.633	0.356	0.305	0.041	0.894	555	115	295	2	1920	0.292	0.106	0.573	0.383	0.987	2.16	8890	90	
3 Kv	75	6	600	0.184	0.067	0.628	0.481	2.50	5.80	4810	75	285	1	2010	0.332	0.126	0.552	0.380	0.786	2.12	8050	90
	75	4	720	0.232	0.084	0.602	0.467	1.58	5.23	4020	75	275	0	2120	0.373	0.141	0.539	0.377	0.622	2.08	7300	90
	75	2	930	0.292	0.106	0.573	0.453	0.987	4.31	3300	80	265	00	2250	0.418	0.159	0.524	0.375	0.495	2.02	6580	90
	75	1	1040	0.332	0.126	0.552	0.445	0.786	4.03	2990	80	260	000	2530	0.470	0.178	0.512	0.370	0.392	1.85	6000	95
	75	0	1170	0.373	0.141	0.539	0.436	0.622	3.79	2670	80	250	0000	2740	0.528	0.200	0.496	0.366	0.310	1.78	5350	95
	75	00	1320	0.418	0.159	0.524	0.428	0.495	3.52	2450	85	245	250 000	2930	0.575	0.221	0.484	0.361	0.263	1.72	4950	95
	75	000	1570	0.470	0.178	0.512	0.420	0.392	3.10	2210	85	240	350 000	3550	0.681	0.262	0.464	0.352	0.190	1.51	4310	100
	75	0000	1800	0.528	0.200	0.496	0.412	0.310	2.87	2010	85	240	500 000	4300	0.814	0.313	0.442	0.341	0.134	1.38	3720	100
	75	250 000	1990	0.575	0.221	0.484	0.403	0.263	2.70	1860	85	240	750 000	5630	0.998	0.385	0.417	0.325	0.091	1.15	3170	105
	75	350 000	2550	0.681	0.262	0.464	0.389	0.190	2.27	1610	90	240	1 000 000	6910	1.152	0.445	0.400	0.313	0.070	1.01	2800	110
	75	500 000	3340	0.814	0.313	0.442	0.375	0.134	1.89	1340	95	240	1 500 000	9460	1.412	0.546	0.374	0.296	0.050	0.806	2350	120
	75	750 000	4570	0.998	0.385	0.417	0.352	0.091	1.53	1060	100	240	2 000 000	11790	1.632	0.633	0.356	0.285	0.041	0.697	2070	125
75	1 000 000	5640	1.152	0.445	0.400	0.341	0.070	1.37	980	100	395	0	2900	0.373	0.141	0.539	0.352	0.622	1.51	9150	100	
75	1 500 000	8090	1.412	0.543	0.374	0.316	0.050	1.02	805	110	385	00	3040	0.418	0.159	0.524	0.350	0.495	1.48	8420	100	
75	2 000 000	10300	1.632	0.633	0.356	0.302	0.041	0.877	685	115	370	000	3190	0.470	0.178	0.512	0.347	0.392	1.46	7620	100	
5 Kv	120	6	740	0.184	0.067	0.628	0.456	2.50	4.47	6700	80	355	0000	3380	0.528	0.200	0.496	0.344	0.310	1.43	6870	100
	115	4	890	0.232	0.084	0.602	0.447	1.58	4.17	5540	80	350	250 000	3590	0.575	0.221	0.484	0.342	0.263	1.39	6410	100
	110	2	1040	0.292	0.106	0.573	0.439	0.987	3.85	4520	80	345	350 000	4230	0.681	0.262	0.464	0.366	0.190	1.24	5640	105
	110	1	1160	0.332	0.126	0.552	0.431	0.786	3.62	4100	80	345	500 000	5040	0.814	0.313	0.442	0.325	0.134	1.15	4940	105
	105	0	1270	0.373	0.141	0.539	0.425	0.622	3.47	3600	80	345	750 000	6430	0.998	0.385	0.417	0.311	0.091	0.975	4250	110
	100	00	1520	0.418	0.159	0.524	0.420	0.495	3.09	3140	85	345	1 000 000	7780	1.152	0.445	0.400	0.302	0.070	0.866	3780	115
	100	000	1710	0.470	0.178	0.512	0.412	0.392	2.91	2860	85	345	1 500 000	10420	1.412	0.546	0.374	0.285	0.050	0.700	3210	125
	95	0000	1870	0.525	0.200	0.496	0.406	0.310	2.74	2480	85	345	2 000 000	12830	1.632	0.633	0.356	0.274	0.041	0.611	2830	130
	90	250 000	2090	0.575	0.221	0.484	0.400	0.263	2.62	2180	85	475	000	3910	0.470	0.178	0.512	0.331	0.392	1.20	8890	105
	90	350 000	2620	0.681	0.262	0.464	0.386	0.190	2.20	1890	90	460	0000	4080	0.528	0.200	0.496	0.329	0.310	1.19	8100	105
	90	500 000	3410	0.814	0.313	0.442	0.369	0.134	1.85	1610	95	450	250 000	4290	0.575	0.221	0.484	0.328	0.263	1.16	7570	105
	90	750 000	4650	0.998	0.385	0.417	0.350	0.091	1.49	1350	100	445	350 000	4990	0.681	0.262	0.464	0.319	0.190	1.05	6720	110
90	1 000 000	5850	1.152	0.445	0.400	0.339	0.070	1.27	1140	105	445	500 000	5820	0.814	0.313	0.442	0.310	0.134	0.930	5950	115	
90	1 500 000	8160	1.412	0.543	0.374	0.316	0.050	1.02	950	110	445	750 000	7450	0.998	0.385	0.417	0.298	0.091	0.807	5130	120	
90	2 000 000	10370	1.632	0.633	0.356	0.302	0.041	0.870	820	115	445	1 000 000	8680	1.152	0.445	0.400	0.290	0.070	0.752	4610	120	
8 Kv	150	6	890	0.184	0.067	0.628	0.431	2.50	3.62	7780	80	445	1 000 000	11420	1.412	0.546	0.374	0.275	0.050	0.615	3330	130
	150	4	1010	0.232	0.084	0.602	0.425	1.58	3.22	6660	85	445	1 500 000	13910	1.632	0.633	0.356	0.264	0.041	0.543	3520	135
	140	2	1150	0.292	0.106	0.573	0.417	0.987	3.06	5400	85	445	2 000 000	16310	1.852	0.723	0.417	0.256	0.030	0.470	3710	140
	140	1	1330	0.332	0.126	0.552	0.411	0.786	2.91	4920	85	445	350 000	5820	0.814	0.313	0.442	0.310	0.134	0.930	5950	115
	135	0	1450	0.373	0.141	0.539	0.408	0.622	2.83	4390	85	445	500 000	7450								

TABLE 11—60-CYCLE CHARACTERISTICS OF SINGLE-CONDUCTOR OIL-FILLED (HOLLOW CORE) PAPER-INSULATED CABLES
Grounded Neutral Service

Voltage Class	Insulation Thickness Mils	INSIDE DIAMETER OF SPRING CORE = 0.5 INCHES										INSIDE DIAMETER OF SPRING CORE = 0.69 INCHES									
		Circular Mils or AWG (B & S)	Weight per 1000 Feet	Diameter of Conductor—inches	GMR of One Conductor ¹ —inches	r _a Reactance at 12 Inches—Ohms Per Phase Per Mile	r _s Reactance of Sheath—Ohms Per Phase Per Mile	r _c Resistance of One Conductor—Ohms Per Phase Per Mile ¹	r _s Resistance of Sheath Ohms Per Phase Per Mile at 50°C.	Shunt Capacitive Reactance—Ohms Per Phase Per Mile ²	Lead Sheath Thickness—Mils	Circular Mils or AWG (B & S)	Weight per 1000 Feet	Diameter of Conductor —inches	GMR of One Conductor ¹ —inches	r _a Reactance at 12 Inches—Ohms Per Phase Per Mile	r _s Reactance of Sheath—Ohms Per Phase Per Mile	r _c Resistance of One Conductor—Ohms Per Phase Per Mile ¹	r _s Resistance of Sheath Ohms Per Phase Per Mile at 50°C.	Shunt Capacitive Reactance—Ohms Per Phase Per Mile ²	Lead Sheath Thickness—Mils
69 Kv	315	000	3980	0.736	0.345	0.431	0.333	0.495	1.182	5240	110	000	4860	0.921	0.439	0.399	0.320	0.392	1.007	4450	115
		0000	4090	0.768	0.356	0.427	0.331	0.392	1.157	5070	110	0000	5090	0.956	0.459	0.398	0.317	0.310	0.985	4350	115
		250 000	4320	0.807	0.373	0.421	0.328	0.310	1.130	4900	110	250 000	5290	0.993	0.480	0.396	0.315	0.283	0.975	4230	115
		350 000	4650	0.837	0.381	0.418	0.325	0.263	1.057	4790	115	350 000	5950	1.050	0.483	0.390	0.310	0.188	0.897	4000	120
		500 000	5180	0.918	0.408	0.410	0.320	0.188	1.009	4470	115	500 000	6700	1.145	0.516	0.382	0.304	0.132	0.850	3700	120
	480	500 000	6100	1.028	0.448	0.399	0.312	0.133	0.905	4070	120	750 000	8080	1.288	0.550	0.374	0.295	0.089	0.759	3140	125
		750 000	7310	1.180	0.505	0.384	0.302	0.089	0.838	3820	120	1 000 000	9440	1.416	0.612	0.360	0.288	0.067	0.688	2750	130
		1 000 000	8630	1.310	0.550	0.374	0.294	0.068	0.752	3380	125	1 500 000	11 970	1.635	0.692	0.346	0.276	0.047	0.601	2750	135
		1 500 000	11 090	1.547	0.639	0.356	0.281	0.048	0.649	2920	130	2 000 000	14 450	1.835	0.763	0.334	0.268	0.038	0.533	2510	140
		2 000 000	13 750	1.760	0.716	0.342	0.270	0.039	0.550	2570	140	0000	6 580	0.956	0.450	0.398	0.295	0.310	0.760	5950	125
115 Kv	560	0000	5 720	0.807	0.373	0.421	0.305	0.310	0.805	6650	120	250 000	6 800	0.983	0.460	0.396	0.294	0.283	0.752	5790	125
		250 000	5 930	0.837	0.381	0.418	0.303	0.263	0.793	6500	120	350 000	7 340	1.050	0.483	0.390	0.290	0.188	0.729	5540	125
		350 000	6 390	0.918	0.408	0.410	0.298	0.188	0.730	6090	125	500 000	8 320	1.146	0.516	0.382	0.284	0.132	0.669	5150	130
		500 000	7 480	1.028	0.448	0.399	0.291	0.133	0.692	5600	125	750 000	9 790	1.286	0.550	0.374	0.277	0.089	0.606	4770	135
		750 000	8 950	1.180	0.505	0.384	0.283	0.089	0.625	5040	130	1 000 000	11 060	1.416	0.612	0.360	0.270	0.067	0.573	4430	135
	650	1 000 000	10 350	1.310	0.550	0.374	0.276	0.068	0.568	4700	135	1 500 000	13 900	1.635	0.692	0.346	0.260	0.047	0.490	3920	145
		1 500 000	12 960	1.547	0.639	0.356	0.265	0.048	0.500	4110	140	2 000 000	16 610	1.835	0.763	0.334	0.251	0.038	0.440	3580	150
		2 000 000	15 530	1.760	0.716	0.342	0.255	0.039	0.447	3710	145	0000	7 390	0.956	0.450	0.398	0.286	0.310	0.678	6590	130
		0000	6 480	0.807	0.373	0.421	0.295	0.310	0.758	7410	125	250 000	7 610	0.983	0.460	0.396	0.285	0.283	0.669	6480	130
		250 000	6 700	0.837	0.381	0.418	0.293	0.263	0.746	7240	125	350 000	8 170	1.050	0.483	0.390	0.281	0.188	0.649	6180	130
138 Kv	560	350 000	7 460	0.918	0.408	0.410	0.288	0.188	0.690	6820	130	500 000	9 180	1.146	0.516	0.382	0.276	0.132	0.601	5790	135
		500 000	8 310	1.028	0.448	0.399	0.282	0.133	0.658	6260	130	750 000	10 660	1.286	0.550	0.374	0.269	0.089	0.545	5320	140
		750 000	9 800	1.180	0.505	0.384	0.274	0.089	0.592	5680	135	1 000 000	12 010	1.416	0.612	0.360	0.263	0.067	0.519	4940	140
		1 000 000	11 270	1.310	0.550	0.374	0.268	0.068	0.541	5240	140	1 500 000	14 450	1.635	0.692	0.346	0.253	0.047	0.462	4460	145
		1 500 000	13 720	1.547	0.639	0.356	0.257	0.048	0.477	4670	145	2 000 000	16 820	1.835	0.763	0.334	0.243	0.038	0.404	4060	155
	650	2 000 000	16 080	1.760	0.716	0.342	0.248	0.039	0.427	4170	150	250 000	8 560	0.983	0.460	0.396	0.275	0.283	0.596	7210	135
		0000	7 600	0.837	0.381	0.418	0.283	0.263	0.660	7980	130	350 000	9 140	1.050	0.483	0.390	0.272	0.188	0.580	6860	135
		250 000	8 390	0.918	0.408	0.410	0.279	0.188	0.611	7520	135	500 000	10 280	1.145	0.516	0.382	0.267	0.132	0.537	6430	140
		350 000	9 270	1.028	0.448	0.399	0.273	0.133	0.585	6980	135	750 000	11 770	1.286	0.550	0.374	0.261	0.089	0.492	5980	145
		500 000	10 840	1.180	0.505	0.384	0.266	0.089	0.532	6320	140	1 000 000	13 110	1.416	0.612	0.360	0.255	0.067	0.469	5540	145
161 Kv	650	1 500 000	15 090	1.547	0.639	0.356	0.246	0.048	0.433	5190	150	1 500 000	15 840	1.635	0.692	0.346	0.236	0.047	0.421	4980	150
		2 000 000	18 000	1.760	0.716	0.342	0.241	0.039	0.391	4710	155	2 000 000	18 840	1.835	0.763	0.334	0.238	0.038	0.369	4600	160
		0000	7 600	0.837	0.381	0.418	0.283	0.263	0.660	7980	130	750 000	15 360	1.286	0.550	0.374	0.238	0.089	0.369	4600	160
		250 000	8 390	0.918	0.408	0.410	0.279	0.188	0.611	7520	135	1 000 000	16 790	1.416	0.612	0.360	0.233	0.067	0.355	7610	160
		350 000	9 270	1.028	0.448	0.399	0.273	0.133	0.585	6980	135	2 000 000	22 990	1.835	0.763	0.334	0.219	0.038	0.315	5960	170
	925	500 000	10 840	1.180	0.505	0.384	0.266	0.089	0.532	6320	140	0000	7 390	0.956	0.450	0.398	0.286	0.310	0.678	6590	130
		750 000	9 800	1.180	0.505	0.384	0.274	0.089	0.592	5680	135	250 000	7 610	0.983	0.460	0.396	0.285	0.283	0.669	6480	130
		1 000 000	11 270	1.310	0.550	0.374	0.268	0.068	0.541	5240	140	350 000	8 170	1.050	0.483	0.390	0.281	0.188	0.649	6180	130
		1 500 000	13 720	1.547	0.639	0.356	0.257	0.048	0.477	4670	145	500 000	9 180	1.146	0.516	0.382	0.276	0.132	0.601	5790	135
		2 000 000	16 080	1.760	0.716	0.342	0.248	0.039	0.427	4170	150	750 000	10 660	1.286	0.550	0.374	0.269	0.089	0.545	5320	140

¹A-c Resistance based on 100% conductivity at 65°C, including 2% allowance for stranding. Above values calculated from "A Set of Curves for Skin Effect in Isolated Tubular Conductors" by A. W. Ewan, G. E. Review, Vol. 33, April 1930.
²For dielectric constant = 3.5.
³Calculated for circular tube as given in *Symmetrical Components* by Wagner & Evans, Ch. VII, page 138.

Positive- and Negative-Sequence Impedances:

(a) Neglecting Sheath Currents;

$$z_1 = z_2 = r_c + j(x_a + x_d)$$

(b) Including Sheath Currents;

$$z_1 = z_2 = r_c + \frac{x_B^2 r_s}{x_m^2 + r_s^2} + j \left(x_a + x_d - \frac{x_B^3}{x_m^2 + r_s^2} \right)$$

Where $x_m = (x_a + x_d)$.

Note: x_d is obtained from Table 12.

Zero-Sequence Impedance:

(Based on all return current in sheath; none in ground)

$$z_0 = r_c + r_s + j(x_a - x_d)$$

to a reasonable figure for cables in air. The current-carrying capacities of cables in air have recently been revised by the IPCEA and are now available in the cable manufacturers' catalogs.

In the discussion on proximity effect it was mentioned that where cables are installed parallel to steel plates, the extra losses arising from proximity to the plate may affect the current-carrying capacity. This reduction in carrying capacity is given by the curves of Fig. 19 which are taken from the test values presented by Booth.

IV. CABLES IN PARALLEL

The problem of current division among paralleled cables is frequently encountered, because in many circuits more than one cable per phase is installed in order to carry the total current. Also, mutual effects may develop between cable circuits which are adjacent throughout their length but which terminate on separate busses. Depending upon the type of circuit, the cable type and configuration, and the system conditions being investigated, the problem may take any of several forms.

TABLE 12—REACTANCE SPACING FACTORS (x_d)*, OHMS PER MILE AT 60 CYCLES

In.	x_d	In.	x_d	In.	x_d	In.	x_d	In.	x_d	In.	x_d	In.	x_d	In.	x_d
.....	2.75	-0.179	5.25	-0.100	7.75	-0.053	10.5	-0.016	15.5	0.031	20.5	0.065	27.0	0.098
0.50	-0.385	3.00	-0.169	5.50	-0.095	8.00	-0.049	11.0	-0.011	16.0	0.035	21.0	0.068	28.0	0.103
0.75	-0.336	3.25	-0.159	5.75	-0.089	8.25	-0.045	11.5	-0.005	16.5	0.039	21.5	0.071	29.0	0.107
1.00	-0.302	3.50	-0.149	6.00	-0.084	8.50	-0.042	12.0	0.0	17.0	0.042	22.0	0.074	30.0	0.111
1.25	-0.274	3.75	-0.141	6.25	-0.079	8.75	-0.038	12.5	0.005	17.5	0.046	22.5	0.076	31.0	0.115
1.50	-0.252	4.00	-0.133	6.50	-0.074	9.00	-0.035	13.0	0.010	18.0	0.049	23.0	0.079	32.0	0.119
1.75	-0.234	4.25	-0.126	6.75	-0.070	9.25	-0.032	13.5	0.014	18.5	0.053	23.5	0.082	33.0	0.123
2.00	-0.217	4.50	-0.119	7.00	-0.065	9.50	-0.028	14.0	0.019	19.0	0.056	24.0	0.084	34.0	0.126
2.25	-0.203	4.75	-0.112	7.25	-0.061	9.75	-0.025	14.5	0.023	19.5	0.059	25.0	0.090	35.0	0.130
2.50	-0.190	5.00	-0.106	7.50	-0.057	10.00	-0.022	15.0	0.027	20.0	0.062	26.0	0.094	36.0	0.133

* $x_d = 0.2794 \frac{f}{60} \log_{10} \frac{S}{12}$, where S is spacing in inches.

It is difficult to anticipate in detail the problems met in practice, but the examples outlined here indicate methods of solution that can be modified to fit actual circumstances.

Almost any problem involving paralleled cables can be represented by simultaneous equations of voltage drops caused by self and mutual impedances but such equations often become numerous and cumbersome. Therefore in approaching most problems it becomes desirable to search about for one or more simplifying assumptions so that the problem can be reduced to simpler terms, still without introducing errors large enough to invalidate the solution. For example, when paralleled cable circuits connect a generating source to a balanced load, it is usually permissible to assume that the total current in each phase is composed only of the respective positive-sequence component: this assumption is based on the unsymmetrical cable-circuit impedances being much smaller than the symmetrical load impedances.

Three outlined examples of calculations on paralleled cables are included here, but they assist only by illustrating general methods, since there are so many different, and more complex, cases to be found in practice.

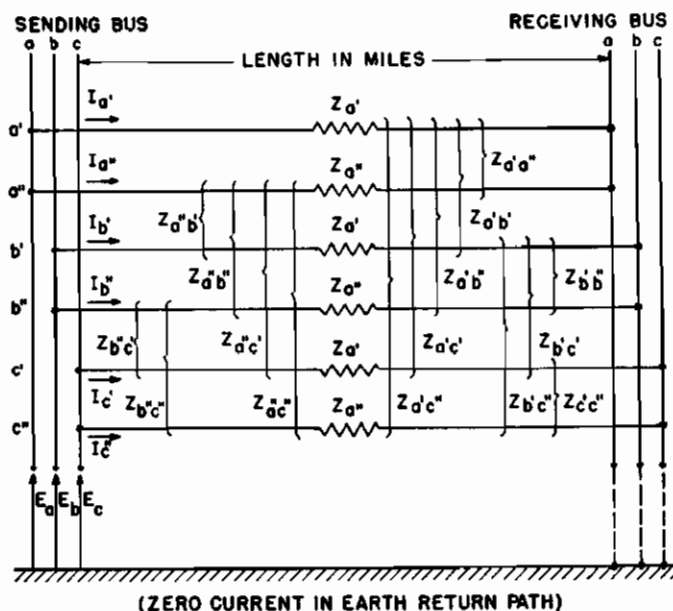

Fig. 16—Equivalent circuit for parallel cables, with open-circuited sheaths and no net ground-return current (see Example 3).

TABLE 13—60-CYCLE CONSTANTS OF TYPICAL CABLES IN OHMS PER PHASE PER MILE

DESCRIPTION OF CABLE	Assumed Operating Kilovolts	POSITIVE- AND NEGATIVE-SEQUENCE					ZERO-SEQUENCE (ALL RETURN IN SHEATH)		
		RESISTANCE*		REACTANCE			Resistance	Reactance	Shunt Capacitive Reactance
		No Sheath Currents	Including Sheath Currents	No Sheath Currents	Including Sheath Currents	Shunt Capacitive Reactance			
Single-Conductor, 1 000 MCM, 30/64 in. Insulation; 1/4 in. Sheath. Three Cables spaced 4 in. horizontally.....	44	0.070	0.114	0.295	0.284	4 780	0.783	0.113	4 780
Single-Conductor, 500 MCM, 9/64 in. Insulation; 6/64 in. Sheath. Three Cables spaced 3, 3, 6 in.....	6.9	0.134	0.162	0.302	0.299	2 440	1.87	0.081	2 440
Single-Conductor Oil-Filled, 750 MCM, inside diam. 0.50 in. 650 mils Insulation; 9/64 in. Sheath. Three Cables spaced 13 in. horizontally.....	161	0.089	0.221	0.422	0.347	6 300	0.631	0.115	6 300
Single-Conductor, 250 MCM, 6/64 in. insulation; 7/64 in. Sheath. Three Sheaths in contact and 4/0 Copper Neutral Wire.....	0.21	0.263	0.239	0.181	0.180	2 270	0.960	0.381	2 270
Three-Conductor belted; Sected, 500 MCM, 7/64 in. Conductor Insulation, 4/64 in. Belt. 7.5/64 in. Sheath.....	6.9	0.134	0.135	0.135	2 410	2.53	0.231	4 670
Three-Conductor Type H; Sected, 500 MCM, 13/64 in. Insulation, 8/64 in. Sheath.....	15	0.134	0.135	0.156	3 400	2.10	0.226	3 400
Three-Conductor Oil-Filled Type H; Sected, 500 MCM, 225 Mils Insulation, 8.5/64 in. Sheath.....	44	0.134	0.135	0.160	3 870	1.94	0.226	3 870

*Conductor temperature 65°C.; Sheath temperature 50°C.

TABLE 14—CURRENT CARRYING CAPACITY OF THREE-CONDUCTOR BELTED PAPER-INSULATED CABLES

Conductor Size AWG or 1000 CM	Conductor type ¹	Number of Equally Loaded Cables in Duct Bank																			
		ONE				THREE				SIX				NINE				TWELVE			
		Per Cent Load Factor																			
		30	50	75	100	30	50	75	100	30	50	75	100	30	50	75	100	30	50	75	100
AMPERES PER CONDUCTOR ²																					
4500 Volts																					
Copper Temperature 85°C																					
6	S	82	80	78	75	81	78	73	68	79	74	68	63	78	72	65	58	76	69	61	54
4	SR	109	106	103	98	108	102	96	89	104	97	89	81	102	94	84	74	100	90	79	69
2	SR	143	139	134	128	139	133	124	115	136	127	115	104	133	121	108	95	130	117	101	89
1	SR	164	161	153	146	159	152	141	130	156	145	130	118	152	138	122	108	148	133	115	100
0	CS	189	184	177	168	184	175	162	149	180	166	149	134	175	159	140	122	170	152	130	114
00	CS	218	211	203	192	211	201	185	170	208	190	170	152	201	181	158	138	195	173	148	128
000	CS	250	242	232	219	242	229	211	193	237	217	193	172	229	206	179	156	223	197	167	145
0000	CS	286	276	264	249	276	260	240	218	270	246	218	194	261	234	202	176	254	223	189	163
250	CS	316	305	291	273	305	288	263	239	297	271	239	212	288	258	221	192	279	244	206	177
300	CS	354	340	324	304	340	321	292	264	332	301	264	234	321	285	245	211	310	271	227	195
350	CS	392	376	357	334	375	353	320	288	366	330	288	255	351	311	266	229	341	296	248	211
400	CS	424	406	385	359	406	380	344	309	395	355	309	272	380	334	285	244	367	317	264	224
500	CS	487	465	439	408	465	433	390	348	451	403	348	305	433	378	320	273	417	357	296	251
600	CS	544	517	487	450	517	480	430	383	501	444	383	334	480	416	350	298	462	393	323	273
750	CS	618	581	550	505	585	541	482	427	566	500	427	371	541	466	390	331	519	439	359	302
		(1.07 at 10°C, 0.92 at 30°C, 0.83 at 40°C, 0.73 at 50°C) ³				(1.07 at 10°C, 0.92 at 30°C, 0.83 at 40°C, 0.73 at 50°C) ³				(1.07 at 10°C, 0.92 at 30°C, 0.83 at 40°C, 0.73 at 50°C) ³				(1.07 at 10°C, 0.92 at 30°C, 0.83 at 40°C, 0.73 at 50°C) ³				(1.07 at 10°C, 0.92 at 30°C, 0.83 at 40°C, 0.73 at 50°C) ³			
7500 Volts																					
Copper Temperature 83°C																					
6	S	81	80	77	74	79	76	72	67	78	74	67	62	77	71	64	57	75	69	60	53
4	SR	107	105	101	97	104	100	94	87	103	96	87	79	100	92	82	73	98	89	77	68
2	SR	140	137	132	126	136	131	122	113	134	125	113	102	130	119	105	93	127	114	99	87
1	SR	161	156	150	143	156	149	138	128	153	142	128	115	149	136	120	105	145	130	112	98
0	CS	186	180	174	165	180	172	156	146	177	163	148	131	172	155	136	120	167	149	128	111
00	CS	214	206	198	188	206	196	181	166	202	180	166	148	196	177	155	135	191	169	145	125
000	CS	243	236	226	214	236	224	206	188	230	211	188	168	223	200	174	152	217	192	163	141
0000	CS	280	270	258	243	270	255	235	214	264	241	213	190	255	229	198	172	247	218	184	159
250	CS	311	300	287	269	300	283	259	235	293	266	235	208	282	252	217	188	273	240	202	174
300	CS	349	336	320	300	335	316	288	260	326	296	259	230	315	279	240	207	304	265	223	190
350	CS	385	369	351	328	369	346	315	283	359	323	282	249	345	305	261	224	333	289	242	206
400	CS	417	399	378	353	398	373	338	303	388	348	303	267	371	317	279	239	360	309	257	220
500	CS	476	454	429	399	454	423	381	341	440	392	340	298	422	369	312	267	406	348	288	245
600	CS	534	508	479	443	507	471	422	376	491	436	375	327	469	408	343	291	451	384	315	267
750	CS	607	576	540	497	575	532	473	413	555	489	418	363	529	455	381	323	507	428	350	295
		(1.08 at 10°C, 0.92 at 30°C, 0.83 at 40°C, 0.72 at 50°C) ³				(1.08 at 10°C, 0.92 at 30°C, 0.83 at 40°C, 0.72 at 50°C) ³				(1.08 at 10°C, 0.92 at 30°C, 0.83 at 40°C, 0.72 at 50°C) ³				(1.08 at 10°C, 0.92 at 30°C, 0.83 at 40°C, 0.72 at 50°C) ³				(1.08 at 10°C, 0.92 at 30°C, 0.83 at 40°C, 0.72 at 50°C) ³			
15 000 Volts																					
Copper Temperature 75°C																					
6	S	78	77	74	71	76	74	69	64	75	70	64	59	73	68	61	54	72	65	57	50
4	SR	102	99	96	92	98	95	89	83	97	91	83	75	95	87	78	69	93	85	73	64
2	SR	132	129	125	119	129	123	115	106	126	117	106	96	123	112	99	88	120	108	93	82
1	SR	151	147	142	135	146	140	131	120	144	133	120	109	140	128	112	99	136	122	107	92
0	CS	175	170	163	155	169	161	150	138	166	153	137	123	161	146	128	112	156	139	120	104
00	CS	200	194	187	177	194	184	170	156	189	175	156	139	183	166	145	127	178	158	135	117
000	CS	230	223	214	202	222	211	195	178	217	199	177	158	210	189	165	143	203	180	153	132
0000	CS	266	257	245	232	253	242	222	202	249	228	201	179	240	215	187	158	233	205	173	149
250	CS	295	284	271	255	281	268	245	221	276	251	220	196	266	239	204	177	257	225	189	163
300	CS	330	317	301	283	316	297	271	245	307	278	244	215	295	264	225	194	285	248	208	178
350	CS	365	349	332	310	348	327	297	267	339	305	266	235	324	289	245	211	313	271	227	193
400	CS	394	377	357	333	375	352	319	286	365	327	285	251	349	307	262	224	336	290	241	206
500	CS	449	429	406	377	428	399	359	321	414	396	319	280	396	346	293	250	379	326	269	229
600	CS	502	479	450	417	476	443	396	352	459	409	351	306	438	380	319	273	420	358	294	249
750	CS	572	543	510	468	540	499	444	393	520	458	391	341	494	425	356	302	471	399	326	275
		(1.09 at 10°C, 0.90 at 30°C, 0.79 at 40°C, 0.67 at 50°C) ³				(1.09 at 10°C, 0.90 at 30°C, 0.79 at 40°C, 0.67 at 50°C) ³				(1.09 at 10°C, 0.90 at 30°C, 0.79 at 40°C, 0.66 at 50°C) ³				(1.09 at 10°C, 0.90 at 30°C, 0.79 at 40°C, 0.66 at 50°C) ³				(1.09 at 10°C, 0.90 at 30°C, 0.79 at 40°C, 0.66 at 50°C) ³			

¹ The following symbols are used here to designate conductor types:
 S—Solid copper, SR—standard round concentric-stranded, CS—compact-sector stranded.
² Current ratings are based on the following conditions:
 a. Ambient earth temperature = 20°C.
 b. 60 cycle alternating current.
 c. Ratings include dielectric loss, and all induced a-c losses.
 d. One cable per duct, all cables equally loaded and in outside ducts only.
³ Multiply tabulated currents by these factors when earth temperature is other than 20°C.

Example 3—Type of Circuit: A three-phase 60-cycle cable circuit connected between a sending and a receiving bus, using single-conductor unsheathed cables, and having two paralleled cables per phase.
 Conditions: The current flowing into the sending bus and out of the receiving bus is nearly balanced three-phase

load current (positive-sequence only), and its magnitude is known. The cable conductors can be of different sizes, and their spacings can be entirely unsymmetrical.
 Problem: To find the division of load current among all conductors.
 Circuit: Refer to Figure 16.

TABLE 15—CURRENT CARRYING CAPACITY OF THREE-CONDUCTOR SHIELDED PAPER-INSULATED CABLES

Conductor Size AWG or 1000CM	Conductor Type ¹	Number of Equally Loaded Cables in Duct Bank																			
		ONE			THREE			SIX			NINE			TWELVE							
		Per Cent Load Factor																			
		30	50	75	100	30	50	75	100	30	50	75	100	30	50	75	100	30	50	75	100
AMPERES PER CONDUCTOR ²																					
15 000 Volts										Copper Temperature 81°C											
6	S	94	91	88	83	91	87	81	75	89	83	74	66	87	78	69	60	84	75	64	56
4	SR	123	120	115	107	119	114	104	95	116	108	95	85	113	102	89	77	109	96	83	72
2	SR	159	154	146	137	153	144	139	121	149	136	120	107	144	129	112	97	139	123	104	90
1	SR	179	174	166	156	172	163	149	136	168	153	136	121	162	145	125	109	158	138	117	100
0	CS	203	195	182	176	196	185	169	154	190	173	154	137	183	164	141	122	178	156	131	112
00	CS	234	224	215	202	225	212	193	175	218	198	174	156	211	187	162	139	203	177	148	127
000	CS	270	258	245	230	258	242	220	198	249	225	198	174	241	212	182	157	232	202	168	144
0000	CS	308	295	281	261	295	276	250	223	285	257	224	196	275	241	205	176	265	227	189	162
250	CS	341	327	310	290	325	305	276	246	315	283	245	215	303	265	224	193	291	250	207	177
300	CS	383	365	344	320	364	339	305	272	351	313	271	236	337	293	246	211	322	276	227	194
350	CS	417	397	375	346	397	369	330	293	383	340	293	255	366	318	267	227	350	301	245	208
400	CS	453	428	403	373	429	396	354	314	413	366	313	273	394	340	285	242	376	320	262	222
500	CS	513	487	450	418	483	446	399	350	467	410	350	303	444	381	318	269	419	358	292	247
600	CS	567	537	501	460	534	491	437	385	513	450	384	330	488	416	346	293	465	390	317	269
750	CS	643	606	562	514	602	551	485	426	576	502	423	365	545	464	383	323	519	432	348	293
(1.08 at 10°C, 0.91 at 30°C, 0.82 at 40°C, 0.71 at 50°C) ³																					
23 000 Volts										Copper Temperature 77°C											
2	SR	156	150	143	134	149	141	130	117	145	132	117	105	140	125	107	84	134	119	100	86
1	SR	177	170	162	152	170	160	145	123	164	149	132	117	159	140	121	105	154	133	112	97
0	CS	200	192	183	172	192	182	166	149	186	169	147	132	178	158	136	118	173	149	126	109
00	CS	227	220	210	197	221	208	189	170	212	193	168	149	202	181	156	134	196	172	144	123
000	CS	262	251	238	223	254	238	216	193	242	220	191	169	230	206	175	150	222	195	162	139
0000	CS	301	289	271	251	291	273	246	219	278	250	215	190	264	233	197	169	255	221	182	157
250	CS	334	315	298	277	321	299	270	239	308	275	236	207	290	258	216	184	270	242	199	170
300	CS	373	349	328	306	354	329	297	263	341	302	259	227	320	283	232	202	309	266	217	186
350	CS	405	379	358	331	384	356	318	283	369	327	280	243	347	305	255	217	335	285	233	199
400	CS	434	409	386	356	412	379	340	302	399	348	298	260	374	325	273	232	359	303	247	211
500	CS	492	465	436	401	461	427	379	335	443	391	333	288	424	363	302	257	400	336	275	230
600	CS	543	516	484	440	512	470	414	366	489	428	365	313	464	396	329	279	441	367	299	248
750	CS	616	583	541	495	577	528	465	407	550	479	402	347	520	439	364	306	490	408	329	276
(1.09 at 10°C, 0.90 at 30°C, 0.80 at 40°C, 0.67 at 50°C) ³																					
34 500 Volts										Copper Temperature 70°C											
0	CS	193	185	176	165	184	174	158	141	178	161	140	124	171	140	120	111	164	142	119	103
00	CS	213	209	199	187	208	197	178	160	202	182	158	140	194	170	145	126	185	161	134	115
000	CS	250	238	225	211	238	222	202	182	229	206	179	158	220	193	165	141	209	182	152	128
0000	CS	288	275	260	241	273	256	229	205	263	234	203	179	251	219	186	160	238	205	170	144
250	CS	316	302	285	266	301	280	253	224	289	258	222	196	276	240	202	174	262	222	187	157
300	CS	352	335	315	293	334	310	278	246	320	284	244	213	304	264	221	190	288	244	203	171
350	CS	384	364	342	318	363	336	301	267	346	308	264	229	329	285	238	204	311	263	217	184
400	CS	413	392	367	341	384	360	321	284	372	329	281	244	352	303	254	216	334	282	232	195
500	CS	468	442	414	381	436	402	358	317	418	367	312	271	393	337	281	238	372	313	256	215
600	CS	514	487	455	416	481	440	391	344	459	401	340	294	430	367	304	250	406	340	277	232
750	CS	584	548	510	466	541	496	435	383	515	447	378	324	481	409	337	284	452	377	304	255
(1.10 at 10°C, 0.89 at 30°C, 0.76 at 40°C, 0.61 at 50°C) ³																					

¹ The following symbols are used here to designate conductor types:
 S—solid copper, SR—standard round concentric-stranded, CS—compact-sector stranded.
² Current ratings are based on the following conditions:
 a. Ambient earth temperature = 20°C.
 b. 60 cycle alternating current.
 c. Ratings include dielectric loss, and all induced a-c losses.
 d. One cable per duct, all cables equally loaded and in outside ducts only.
³ Multiply tabulated currents by these factors when earth temperature is other than 20°C.

Complete voltage drop equations:

$$\begin{aligned}
 E_a &= I_a Z_a + I_a'' Z_a'' + I_b Z_b + I_b'' Z_b'' + I_c Z_c + I_c'' Z_c'' \\
 E_a'' &= I_a Z_a'' + I_a'' Z_a + I_b Z_b'' + I_b'' Z_b + I_c Z_c'' + I_c'' Z_c \\
 E_b &= I_a Z_a + I_a'' Z_a'' + I_b Z_b + I_b'' Z_b'' + I_c Z_c + I_c'' Z_c'' \\
 E_b'' &= I_a Z_a'' + I_a'' Z_a + I_b Z_b'' + I_b'' Z_b + I_c Z_c'' + I_c'' Z_c \\
 E_c &= I_a Z_a + I_a'' Z_a'' + I_b Z_b + I_b'' Z_b'' + I_c Z_c + I_c'' Z_c'' \\
 E_c'' &= I_a Z_a'' + I_a'' Z_a + I_b Z_b'' + I_b'' Z_b + I_c Z_c'' + I_c'' Z_c
 \end{aligned}$$

Simplifying assumptions: It is apparent that $E_a = E_a''$, $E_b = E_b''$, and $E_c = E_c''$; therefore these voltages can be eliminated by subtraction. Also if one ampere positive sequence current is assumed to flow through the overall circuit, then $I_a'' = 1.0 - I_a$, $I_b'' = a^2 - I_b$, and $I_c'' = a - I_c$.

Applying these assumptions leads to a set of three simultaneous equations relating three currents:

Modified equations:

$$\begin{aligned}
 I_a (Z_a + Z_a'' - 2Z_a''') + I_b (Z_b + Z_b'' - Z_b'' - Z_a''') + I_c (Z_c + Z_c'' - Z_c'' - Z_a''') &= (Z_a'' - Z_a''') \\
 + a^2 (Z_a'' - Z_a''') + a (Z_c'' - Z_c'''), \\
 I_a (Z_a'' + Z_a'''' - Z_a'' - Z_a''') + I_b (Z_b'' + Z_b'' - 2Z_b''') + I_c (Z_c'' + Z_c'''' - Z_c'' - Z_b''') &= (Z_a'''' - Z_a''') \\
 + a^2 (Z_b'' - Z_b''') + a (Z_b'''' - Z_b'''), \\
 I_a (Z_a'' + Z_a'''' - Z_a'' - Z_a''') + I_b (Z_b'' + Z_b'''' - Z_b'' - Z_b''') + I_c (Z_c'' + Z_c'''' - 2Z_c''') &= (Z_c'''' - Z_a''') \\
 + a^2 (Z_b'''' - Z_b''') + a (Z_c'' - Z_c''').
 \end{aligned}$$

TABLE 16—CURRENT CARRYING CAPACITY FOR THREE-CONDUCTOR OIL-FILLED PAPER INSULATED CABLES (amperes per conductor)*

Circular Mils. or A. W. G. (B. & S.)	Rated Line Voltage—Grounded Neutral		
	34 500	46 000	69 000
	Maximum Copper Temperature—Deg. C.		
	75	75	75
0	168
00	190	190	...
000	210	210	210
0000	240	240	240
250 000	265	265	265
300 000	295	295	295
350 000	320	320	320
400 000	342	342	342
500 000	382	382	380
600 000	417	417	412
700 000	445	445	440
750 000	460	460	455

Deg. C.	Correction Factor for Various Earth Temps.		
10	1.08	1.08	1.08
20	1.00	1.00	1.00
30	0.90	0.90	0.90
40	.79	.79	.79

75% load factor assumed.
 Ratings include dielectric loss and extra a-c. losses such as sheath and proximity loss.
 Above values apply specifically to sector shaped conductors. For round conductors multiply by 0.99.
 *Applies to three similar loaded cables in a duct bank; for six loaded cables in a duct bank, multiply above values by 0.88.

After substituting the proper self and mutual impedance values as defined later, these equations can be solved by the method of determinants for current distribution, based on a total of 1.0 ampere positive-sequence current in the circuit. To obtain actual currents, the distribution factors must be multiplied by the actual load current in amperes.

Apparent conductor impedances: Using the current-distribution factors for each conductor to solve the complete voltage drop equations, an "apparent" impedance for each phase of the circuit can be calculated. This apparent impedance is valid only for the particular current division calculated:

Apparent impedance of phase a

$$= \frac{E_{a'}}{I_{a'} + I_{a''}} = \frac{E_{a'}}{1.0} = E_{a'} = E_{a''}, \text{ ohms.}$$

Apparent impedance of phase b

$$= \frac{E_{b'}}{I_{b'} + I_{b''}} = \frac{E_{b'}}{a^2} = aE_{b'} = aE_{b''}, \text{ ohms.}$$

Apparent impedance of phase c

$$= \frac{E_{c'}}{I_{c'} + I_{c''}} = \frac{E_{c'}}{a} = a^2E_{c'} = a^2E_{c''}, \text{ ohms.}$$

Supplementary equations: The original assumption of positive-sequence current flow through the circuit precludes the existence of any net ground return current. This assumption simplifies the determination of the various self and mutual impedances, because the effects of a

ground return path may be ignored with very small error:

$$Z_{a'} = l(r_c + jx_a)$$

where

l = circuit length in miles.

r_c = a-c. resistance of conductor a' , ohms per mile.

x_a = reactance of conductor a' , to a twelve inch radius, ohms per mile.

$$= j0.2794 \log_{10} \frac{12}{\text{GMR}_1 \text{ of conductor } a', \text{ inches}}$$

$Z_{a''}$, $Z_{b'}$, $Z_{b''}$, $Z_{c'}$, and $Z_{c''}$ are determined similarly, based on the respective conductor characteristics.

$Z_{a'a''} = l \cdot j0.2794 \log_{10} \frac{12}{S_{a'a''}} = l(-x_d)$ where $S_{a'a''}$ is the axial spacing in inches between conductors a' and a'' . The remaining mutual impedance are calculated similarly, using the appropriate spacing for each.

A series of more complex examples of the above type of problem is described by Wagner and Muller.⁸

Example 4—Type of circuit: A three-phase 60-cycle cable circuit connected between a sending and a receiving bus, using two dissimilar three-conductor lead sheathed cables in parallel.

Conditions: Each cable contains three conductors that, by the nature of the cable construction, are symmetrically transposed so that the flow of positive- or negative-sequence currents will cause no zero-sequence voltage drops. Therefore, the sequence networks are not interdependent and an impedance value of each sequence may be calculated and used independently.

Problem: To find the zero-sequence impedance of the entire cable circuit, and to determine how zero-sequence current divides between cables.

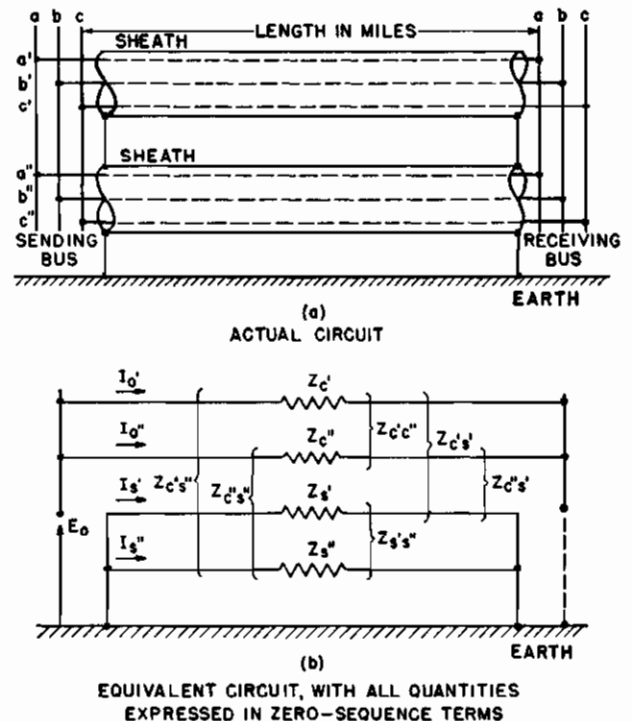

Fig. 17—Actual and equivalent zero-sequence circuit for two parallel three-conductor lead-sheathed cables (see Example 4).

TABLE 17—CURRENT CARRYING CAPACITY OF THREE-CONDUCTOR GAS-FILLED PAPER-INSULATED CABLES

Conductor Size AWG or MCM	Conductor Type (1)	Number of Equally Loaded Cables																			
		ONE				THREE				SIX				NINE				TWELVE			
		Per Cent Load Factor																			
		30	50	75	100	30	50	75	100	30	50	75	100	30	50	75	100	30	50	75	100
APPROXIMATE AMPERES PER CONDUCTOR ²																					
15 000 Volts																					
Copper Temperature 81°C																					
2	SR	159	154	146	137	153	144	133	121	149	136	120	107	144	129	112	97	139	123	104	90
1	SR	179	174	166	156	172	163	149	136	168	153	136	121	162	145	125	109	158	138	117	100
0	CS	203	195	182	176	196	185	169	154	190	173	154	137	183	164	141	122	178	156	131	112
00	CS	234	224	215	202	225	212	193	175	218	198	174	156	211	187	162	139	203	177	148	127
000	CS	270	258	245	230	258	242	220	198	249	225	198	174	241	212	182	157	232	202	168	144
0000	CS	308	295	281	261	295	276	250	223	285	257	224	196	275	241	205	176	265	227	189	162
250	CS	341	327	310	290	325	305	276	246	315	283	245	215	303	265	224	193	291	250	207	177
350	CS	417	397	375	346	397	369	330	293	383	340	293	255	366	318	267	227	350	301	245	208
500	CS	513	487	450	418	483	446	399	350	467	410	350	303	444	381	318	269	419	358	292	247
750	CS	643	606	562	514	602	551	485	426	576	502	423	365	545	464	383	323	519	432	348	293
		(1.08 at 10°C, 0.91 at 30°C, 0.82 at 40°C, 0.71 at 50°C) ³				(1.08 at 10°C, 0.91 at 30°C, 0.82 at 40°C, 0.71 at 50°C) ³				(1.08 at 10°C, 0.91 at 30°C, 0.82 at 40°C, 0.71 at 50°C) ³				(1.08 at 10°C, 0.91 at 30°C, 0.82 at 40°C, 0.70 at 50°C) ³				(1.08 at 10°C, 0.91 at 30°C, 0.81 at 40°C, 0.70 at 50°C) ³			
23 000 Volts																					
Copper Temperature 77°C																					
2	SR	156	150	143	134	149	141	130	117	145	132	117	105	140	125	107	84	134	119	100	86
1	SR	177	170	162	152	170	160	145	133	164	149	132	117	159	140	121	105	154	133	112	97
0	CS	200	192	183	172	192	182	166	149	186	169	147	132	178	158	136	118	173	149	126	109
00	CS	227	220	210	197	221	208	180	170	212	193	168	149	202	181	156	134	196	172	144	123
000	CS	262	251	238	223	254	238	216	193	242	220	191	169	230	206	175	150	222	195	162	139
0000	CS	301	289	271	251	291	273	246	219	278	250	215	190	264	233	197	169	255	221	182	157
250	CS	334	315	298	277	321	299	270	239	308	275	236	207	290	258	216	184	279	242	199	170
350	CS	405	379	358	331	384	356	318	283	369	327	280	243	347	305	255	217	335	285	233	199
500	CS	492	465	436	401	461	427	379	335	443	391	333	288	424	363	302	257	400	336	275	230
750	CS	616	583	541	495	577	528	465	407	550	479	402	347	520	439	364	306	490	408	329	276
		(1.09 at 10°C, 0.90 at 30°C, 0.80 at 40°C, 0.67 at 50°C) ³				(1.09 at 10°C, 0.90 at 30°C, 0.80 at 40°C, 0.67 at 50°C) ³				(1.09 at 10°C, 0.90 at 30°C, 0.79 at 40°C, 0.67 at 50°C) ³				(1.09 at 10°C, 0.90 at 30°C, 0.79 at 40°C, 0.66 at 50°C) ³				(1.09 at 10°C, 0.90 at 30°C, 0.79 at 40°C, 0.65 at 50°C) ³			
34 500 Volts																					
Copper Temperature 70°C																					
0	CS	203	194	185	173	193	183	166	148	187	169	147	130	180	156	135	116	172	149	125	108
00	CS	230	220	209	196	218	207	187	168	212	191	166	147	203	178	152	132	194	169	141	121
000	CS	262	250	236	222	250	233	212	191	240	216	188	166	231	203	173	148	220	191	160	134
0000	CS	302	289	273	253	287	269	240	215	276	246	213	188	264	230	195	168	250	215	179	151
250	CS	332	317	300	279	316	294	266	235	304	271	233	206	290	252	212	183	275	233	196	165
350	CS	403	382	359	334	382	353	316	280	363	323	277	240	346	300	250	214	327	276	228	193
500	CS	492	464	435	400	458	422	376	333	439	386	328	285	413	354	295	250	390	329	269	226
750	CS	613	575	536	490	570	521	457	402	540	469	397	340	505	430	354	298	475	396	320	268
		(1.10 at 10°C, 0.89 at 30°C, 0.76 at 40°C, 0.61 at 50°C) ³				(1.10 at 10°C, 0.89 at 30°C, 0.76 at 40°C, 0.60 at 50°C) ³				(1.10 at 10°C, 0.89 at 30°C, 0.76 at 40°C, 0.60 at 50°C) ³				(1.10 at 10°C, 0.88 at 30°C, 0.75 at 40°C, 0.58 at 50°C) ³				(1.10 at 10°C, 0.88 at 30°C, 0.74 at 40°C, 0.56 at 50°C) ³			

- 1 The following symbols are used here to designate conductor types: SR—standard round concentric-stranded, CS—compact-sector stranded.
- 2 Current ratings are based on the following conditions:
 - a. Ambient earth temperature = 20°C.
 - b. 60 cycle alternating current.
 - c. Ratings include dielectric loss, and all induced a-c losses.
 - d. One cable per duct, all cables equally loaded and in outside ducts only.
- 3 Multiply tabulated currents by these factors when earth temperature is other than 20°C.

Circuit: Refer to Fig. 17. The three actual conductors in each cable have been reduced to one equivalent conductor in this figure, and all impedances are to be expressed in zero-sequence terms considering the earth as a return path for each circuit.

Complete voltage drop equations:

$$\begin{aligned}
 E_0 &= I_0 Z_c + I_0' Z_{c'} + I_s Z_{c_s} + I_s' Z_{c_s'} \\
 E_0 &= I_0 Z_{c''} + I_0' Z_{c'''} + I_s Z_{c_s''} + I_s' Z_{c_s'''} \\
 0 &= I_0 Z_{c_s''} + I_0' Z_{c_s'''} + I_s Z_s + I_s' Z_s' \\
 0 &= I_0 Z_{c_s'''} + I_0' Z_{c_s''} + I_s Z_s' + I_s' Z_s
 \end{aligned}$$

The voltage drop E_0 can be eliminated by subtraction, and the sheath currents can be solved in terms of conductor currents by using the last two equations only. Also, it is convenient to assume that the total zero-sequence current flowing into the sending bus is one ampere, which makes

$$I_0' = 1.0 - I_0.$$

After making these changes, the following single equation results:

Modified equation:

$$\begin{aligned}
 I_0' [& (Z_c - Z_{c'}) (Z_s Z_s'' - Z_s' Z_s') + (Z_c' - Z_{c''}) (Z_s Z_s'' - Z_s' Z_s') \\
 & + (Z_c'' - Z_{c'''}) (Z_c' Z_s' Z_s'' - Z_c'' Z_s' Z_s') + (Z_c''' - Z_{c_s}) \\
 & (Z_c'' Z_s' Z_s'' - Z_c''' Z_s' Z_s') + (Z_c_s'' - Z_{c_s'''}) (Z_c' Z_s' Z_s'' - Z_c'' Z_s' Z_s') \\
 & + (Z_c_s''' - Z_{c_s}) (Z_c'' Z_s' Z_s'' - Z_c''' Z_s' Z_s')] = (Z_c'' - Z_{c_c'}) \\
 & (Z_s Z_s'' - Z_s' Z_s') + (Z_c_s'' - Z_{c_s'}) (Z_c'' Z_s' Z_s'' - Z_c''' Z_s' Z_s') \\
 & + (Z_c_s''' - Z_{c_s'}) (Z_c'' Z_s' Z_s'' - Z_c''' Z_s' Z_s')
 \end{aligned}$$

This equation furnishes a solution for I_0' , from which I_0' follows directly. To find the zero-sequence impedance of the entire circuit requires that one of the complete voltage drop equations be solved for E_0 . Then

$$Z_0 = \frac{E_0}{I_0 + I_0'} = \frac{E_0}{1.0} = E_0, \text{ ohms.}$$

Supplementary equations: The equations necessary to determine each impedance value are shown here: every impedance must be expressed in zero-sequence terms, with the effect of earth as a return path included.

TABLE 18—CURRENT CARRYING CAPACITY OF SINGLE-CONDUCTOR SOLID PAPER-INSULATED CABLES

Conductor Size AWG or MCM	Number of Equally Loaded Cables in Duet Bank															
	THREE				SIX				NINE				TWELVE			
	Per Cent Load Factor															
	30	50	75	100	30	50	75	100	30	50	75	100	30	50	75	100
AMPERES PER CONDUCTOR ¹																
7500 Volts																
Copper Temperature, 85°C																
6	116	113	109	103	115	110	103	96	113	107	98	90	111	104	94	85
4	154	149	142	135	152	144	134	125	149	140	128	116	147	136	122	110
2	202	196	186	175	199	189	175	162	196	183	167	151	192	178	159	142
1	234	226	214	201	230	218	201	185	226	210	190	172	222	204	181	162
0	270	262	245	232	266	251	231	212	261	242	219	196	256	234	208	184
00	311	300	283	262	309	290	270	241	303	278	250	224	295	268	236	208
000	356	344	324	300	356	333	303	275	348	319	285	255	340	308	270	236
0000	412	395	371	345	408	380	347	314	398	364	325	290	390	352	307	269
250	456	438	409	379	449	418	379	344	437	400	356	316	427	386	336	294
300	512	491	459	423	499	464	420	380	486	442	394	349	474	428	371	325
350	561	537	500	460	546	507	457	403	532	483	429	379	518	466	403	352
400	607	580	540	496	593	548	493	445	576	522	461	407	560	502	434	378
500	692	660	611	561	679	626	560	504	659	597	524	459	641	571	490	427
600	772	735	679	621	757	696	621	557	733	663	579	506	714	632	542	470
700	846	804	741	677	827	758	674	604	802	721	629	548	779	688	587	508
750	881	837	771	702	860	789	700	627	835	750	651	568	810	714	609	526
800	914	866	797	725	892	817	725	648	865	776	674	588	840	740	630	544
1000	1037	980	898	816	1012	922	815	725	980	874	756	657	950	832	705	606
1250	1176	1108	1012	914	1145	1039	914	809	1104	981	845	730	1068	941	784	673
1500	1300	1224	1110	1000	1268	1146	1000	884	1220	1078	922	794	1178	1032	855	731
1750	1420	1332	1204	1080	1382	1240	1078	949	1342	1166	992	851	1280	1103	919	783
2000	1546	1442	1300	1162	1500	1343	1162	1019	1442	1260	1068	914	1385	1190	986	839
(1.07 at 10°C, 0.92 at 30°C, 0.83 at 40°C, 0.73 at 50°C) ²				(1.07 at 10°C, 0.92 at 30°C, 0.83 at 40°C, 0.73 at 50°C) ²				(1.07 at 10°C, 0.92 at 30°C, 0.83 at 40°C, 0.73 at 50°C) ²				(1.07 at 10°C, 0.92 at 30°C, 0.83 at 40°C, 0.73 at 50°C) ²				
15 000 Volts																
Copper Temperature, 81°C																
6	113	110	105	100	112	107	100	93	110	104	96	87	108	101	92	83
4	149	145	138	131	147	140	131	117	144	136	125	114	142	132	119	107
2	195	190	180	170	193	183	170	157	189	177	161	146	186	172	154	137
1	226	218	208	195	222	211	195	179	218	204	185	167	214	197	175	157
0	256	248	234	220	252	239	220	203	247	230	209	188	242	223	198	177
00	297	287	271	254	295	278	253	232	287	265	239	214	283	257	226	202
000	344	330	312	290	341	320	293	267	333	306	274	245	327	296	260	230
0000	399	384	361	335	392	367	335	305	383	352	315	280	374	340	298	263
250	440	423	396	367	432	404	367	334	422	387	345	306	412	372	325	286
300	490	470	439	406	481	449	406	369	470	429	382	338	457	413	359	316
350	539	516	481	444	527	491	443	401	514	468	416	367	501	450	391	342
400	586	561	522	480	572	530	478	432	556	506	447	395	542	485	419	366
500	669	639	592	543	655	605	542	488	636	577	507	445	618	551	474	412
600	746	710	656	601	727	668	598	537	705	637	557	488	685	608	521	452
700	810	772	712	652	790	726	647	581	766	691	604	528	744	659	564	488
750	840	797	736	674	821	753	672	602	795	716	625	547	772	684	584	505
800	869	825	762	696	850	780	695	622	823	741	646	565	800	707	604	522
1000	991	939	864	785	968	882	782	697	933	832	724	631	903	794	675	581
1250	1130	1067	975	864	1102	1000	883	784	1063	941	816	706	1026	898	759	650
1500	1250	1176	1072	966	1220	1105	972	856	1175	1037	892	772	1133	987	828	707
1750	1368	1282	1162	1044	1330	1198	1042	919	1278	1121	958	824	1230	1063	886	755
2000	1464	1368	1233	1106	1422	1274	1105	970	1360	1192	1013	869	1308	1125	935	795
(1.08 at 10°C, 0.92 at 30°C, 0.82 at 40°C, 0.71 at 50°C) ²				(1.08 at 10°C, 0.92 at 30°C, 0.82 at 40°C, 0.71 at 50°C) ²				(1.08 at 10°C, 0.92 at 30°C, 0.82 at 40°C, 0.71 at 50°C) ²				(1.08 at 10°C, 0.92 at 30°C, 0.82 at 40°C, 0.71 at 50°C) ²				
23 000 Volts																
Copper Temperature, 77°C																
2	186	181	172	162	184	175	162	150	180	169	154	140	178	164	147	132
1	214	207	197	186	211	200	185	171	206	193	176	159	203	187	167	150
0	247	239	227	213	244	230	213	196	239	222	197	182	234	216	192	171
00	283	273	258	242	278	263	243	221	275	253	225	205	267	245	217	193
000	326	314	296	277	320	302	276	252	315	290	259	233	307	280	247	220
0000	376	362	340	317	367	345	315	288	360	332	297	265	351	320	281	250
250	412	396	373	346	405	380	346	316	396	365	326	290	386	351	307	273
300	463	444	416	386	450	422	382	349	438	404	360	319	428	389	340	301
350	508	488	466	422	493	461	418	380	481	442	393	347	468	424	369	326
400	548	525	491	454	536	498	451	409	521	478	423	373	507	453	398	349
500	627	600	559	514	615	570	514	464	597	546	480	423	580	521	450	392
600	695	663	616	566	684	632	568	511	663	603	529	466	645	577	496	431
700	765	729	675	620	744	689	617	554	725	656	574	503	703	627	538	467
750	797	759	702	643	779	717	641	574	754	681	596	527	732	650	558	483
800	826	786	726	665	808	743	663	595	782	706	617	540	759	674	576	500
1000	946	898	827	752	921	842	747	667	880	797	692	603	860	759	646	560
1250	1080	1020	935	848	1052	957	845	751	1014	904	781	676	980	858	725	630
1500	1192	1122	1025	925	1162	1053	926	818	1118	993	855	736	1081	940	791	682
1750	1296	1215	1106	994	1256	1130	991	875	1206	1067	911	785	1162	1007	843	720
2000	1390	1302	1180	1058	1352	1213	1053	928	1293	1137	967	831	1240	1073	893	760
(1.09 at 10°C, 0.90 at 30°C, 0.80 at 40°C, 0.68 at 50°C) ²				(1.09 at 10°C, 0.90 at 30°C, 0.80 at 40°C, 0.68 at 50°C) ²				(1.09 at 10°C, 0.90 at 30°C, 0.80 at 40°C, 0.68 at 50°C) ²				(1.09 at 10°C, 0.90 at 30°C, 0.80 at 40°C, 0.68 at 50°C) ²				

Continued

TABLE 18—CURRENT CARRYING CAPACITY OF SINGLE-CONDUCTOR SOLID PAPER-INSULATED CABLES
(Continued)

Conductor Size AWG or MCM	Number of Equally Loaded Cables in Duct Bank															
	THREE				SIX				NINE				TWELVE			
	Per Cent Load Factor															
	30	50	75	100	30	50	75	100	30	50	75	100	30	50	75	100
AMPERES PER CONDUCTOR ¹																
34 500 Volts								Copper Temperature, 70°C								
0	227	221	209	197	225	213	197	182	220	205	187	169	215	199	177	158
00	260	251	239	224	255	242	224	205	249	234	211	190	245	226	200	179
000	299	290	273	256	295	278	256	235	288	268	242	217	282	259	230	204
0000	341	330	312	291	336	317	291	267	328	304	274	246	321	293	259	230
250	380	367	345	322	374	352	321	294	364	337	303	270	356	324	286	253
300	422	408	382	355	416	390	356	324	405	374	334	298	395	359	315	278
350	464	446	419	389	455	426	388	353	443	408	364	324	432	392	343	302
400	502	484	451	419	491	460	417	379	478	440	390	347	466	421	368	323
500	575	551	514	476	562	524	474	429	547	500	442	392	532	479	416	364
600	644	616	573	528	629	584	526	475	610	556	491	433	593	532	459	401
700	710	675	626	577	690	639	574	517	669	608	535	470	649	580	500	435
750	736	702	651	598	718	664	595	535	696	631	554	486	675	602	518	450
800	765	730	676	620	747	690	617	555	723	654	574	503	700	624	535	465
1000	875	832	766	701	852	783	698	624	823	741	646	564	796	706	601	520
1250	994	941	864	786	967	882	782	696	930	833	722	628	898	790	670	577
1500	1098	1036	949	859	1068	972	856	760	1025	914	788	682	988	865	730	626
1750	1192	1123	1023	925	1156	1048	919	814	1109	984	845	730	1066	929	780	668
2000	1275	1197	1088	981	1234	1115	975	860	1182	1045	893	770	1135	985	824	704
2500	1418	1324	1196	1072	1367	1225	1064	936	1305	1144	973	834	1248	1075	893	760
(1.10 at 10°C, 0.89 at 30°C, 0.76 at 40°C, 0.61 at 50°C) ²				(1.10 at 10°C, 0.89 at 30°C, 0.76 at 40°C, 0.61 at 50°C) ²				(1.10 at 10°C, 0.89 at 30°C, 0.76 at 40°C, 0.60 at 50°C) ²				(1.10 at 10°C, 0.89 at 30°C, 0.76 at 40°C, 0.60 at 50°C) ²				
46 000 Volts								Copper Temperature, 65°C								
000	279	270	256	240	274	259	239	221	268	249	226	204	262	241	214	191
0000	322	312	294	276	317	299	274	251	309	287	259	232	302	276	244	217
250	352	340	321	300	346	326	299	274	336	313	282	252	329	301	266	236
300	394	380	358	334	385	364	332	304	377	349	313	280	367	335	295	260
350	433	417	392	365	425	398	364	331	413	382	341	304	403	366	321	283
400	469	451	423	393	459	430	391	356	446	411	367	326	433	394	344	307
500	534	512	482	444	522	487	441	400	506	464	412	365	492	444	386	339
600	602	577	538	496	589	546	494	447	570	520	460	406	553	497	430	377
700	663	633	589	542	645	598	538	486	626	569	502	441	605	542	468	408
750	689	658	611	561	672	622	559	504	650	590	520	457	629	562	485	422
800	717	683	638	583	698	645	578	522	674	612	538	472	652	582	501	436
1000	816	776	718	657	794	731	653	585	766	691	604	528	740	657	562	487
1250	927	879	810	738	900	825	732	654	865	777	675	589	834	736	626	541
1500	1020	968	887	805	992	904	799	703	951	850	735	638	914	802	679	585
1750	1110	1047	959	867	1074	976	859	762	1028	915	788	682	987	862	726	623
2000	1184	1115	1016	918	1144	1035	909	805	1094	970	833	718	1048	913	766	656
2500	1314	1232	1115	1002	1265	1138	994	875	1205	1062	905	778	1151	996	830	708
(1.11 at 10°C, 0.87 at 30°C, 0.73 at 40°C, 0.54 at 50°C) ²				(1.11 at 10°C, 0.87 at 30°C, 0.72 at 40°C, 0.53 at 50°C) ²				(1.11 at 10°C, 0.87 at 30°C, 0.72 at 40°C, 0.52 at 50°C) ²				(1.12 at 10°C, 0.87 at 30°C, 0.70 at 40°C, 0.51 at 50°C) ²				
69 000 Volts								Copper Temperature, 60°C								
350	395	382	360	336	387	364	333	305	375	348	312	279	365	332	293	259
400	428	413	389	362	418	393	358	328	405	375	335	300	394	358	315	278
500	489	470	441	409	477	446	406	370	461	425	379	337	447	405	354	312
600	545	524	490	454	532	496	450	409	513	471	419	371	497	448	391	343
700	599	573	536	495	582	543	490	444	561	514	455	403	542	489	425	372
750	623	597	556	514	605	562	508	460	583	533	472	417	563	506	439	384
800	644	617	575	531	626	582	525	475	603	554	487	430	582	523	453	396
1000	736	702	652	599	713	660	592	533	685	622	547	481	660	589	508	442
1250	832	792	734	672	806	742	664	595	772	698	610	535	741	650	564	489
1500	918	872	804	733	886	814	724	647	848	763	664	580	812	718	612	529
1750	994	942	865	788	957	876	776	692	913	818	711	618	873	770	653	563
2000	1066	1008	924	840	1020	931	822	732	972	868	750	651	927	814	688	592
2500	1163	1096	1001	903	1115	1013	892	791	1060	942	811	700	1007	880	741	635
(1.13 at 10°C, 0.85 at 30°C, 0.67 at 40°C, 0.42 at 50°C) ²				(1.13 at 10°C, 0.85 at 30°C, 0.66 at 40°C, 0.40 at 50°C) ²				(1.13 at 10°C, 0.84 at 30°C, 0.65 at 40°C, 0.36 at 50°C) ²				(1.14 at 10°C, 0.84 at 30°C, 0.64 at 40°C, 0.32 at 50°C) ²				

¹Current ratings are based on the following conditions:
a. Ambient earth temperature = 20°C.
b. 60 cycle alternating current.
c. Sheaths bonded and grounded at one point only (open circuited sheaths).
d. Standard concentric stranded conductors.
e. Ratings include dielectric loss and skin effect.
f. One cable per duct, all cables equally loaded and in outside ducts only.
²Multiply tabulated values by these factors when earth temperature is other than 20°C.

$Z_{c'} = l[r_c + r_o + j(x_a + x_o - 2x_d)]$ ohms, where l = circuit length in miles, and the other terms are defined as for Eq. (19).

$Z_{c''}$ is defined similarly.

$Z_{c_1'} = l[3r_o + r_o + j(3x_a + x_o)]$ ohms, where the terms are defined as for Eq. (23).

$Z_{c_1''}$ is determined similarly.

$Z_{c_2'} = l[r_c + j(3x_a + x_o)]$ ohms, where the terms are defined as for Eq. (26).

$Z_{c_2''}$ is determined similarly.

$Z_{c_3'} = Z_{c_3''} = Z_{c_4'} = Z_{c_4''} = l[r_o + j(x_o - 3x_d)]$ ohms, where

$$x_d = 0.2794 \log_{10} \frac{S}{12^2}$$

using for S the center-to-center spacing between cables,³ in inches.

A more general version of the above type of problem, covering those cases where the cables are not necessarily bussed together, is described by Cheek.⁹

Example 5—The use of complex GMR's and GMD's will very often reduce a complicated problem to workable terms. The use and significance² of these factors should be studied thoroughly before attempting a solution by this method (see Chap. 3).

TABLE 19—CURRENT CARRYING CAPACITY FOR SINGLE-CONDUCTOR OIL-FILLED PAPER-INSULATED CABLES (amperes per conductor)*

Circular Mils. or A.W.G. (B.& S.)	Rated Line Voltage—Grounded Neutral				
	34 500	46 000	69 000	115 000	138 000
	Maximum Copper Temperature—Deg. C.				
	75	75	75	70	70
0	256
00	287	286	282
000	320	310	300
0000	378	367	367	347	335
250 000	405	395	390	365	352
300 000	450	440	430	402	392
350 000	492	482	470	438	427
400 000	528	512	502	470	460
500 000	592	592	568	530	522
600 000	655	650	628	585	578
700 000	712	710	688	635	630
750 000	742	740	715	667	658
800 000	767	765	740	685	680
1 000 000	872	870	845	775	762
1 250 000	990	982	955	875	852
1 500 000	1 082	1 075	1 043	957	935
1 750 000	1 165	1 162	1 125	1 030	1 002
2 000 000	1 240	1 240	1 200	1 100	1 070
Deg. C.	Correction Factor for Various Earth Temps.				
10	1.08	1.08	1.08	1.08	1.09
20	1.00	1.00	1.00	1.00	1.00
30	0.90	0.90	0.90	0.89	0.89
40	.79	.79	.79	.77	.77

75% load factor assumed.
Ratings include dielectric loss and skin effect.
Ratings based on open-circuited sheath operation; i.e.—no sheath loss considered.
*Applies to three similar loaded cables in a duct bank; for six loaded cables in a duct bank, multiply above values by 0.91.

TABLE 20—SUGGESTED WITHSTAND IMPULSE VOLTAGES FOR CABLES WITH METALLIC COVERING*

Insulation Class kv	Basic Impulse Insulation Level for Equipment	Solid-Paper Insulation		Oil-Filled Paper Insulation	
		Insulation Thickness mils	Withstand Voltage kv	Insulation Thickness mils	Withstand Voltage kv
1.2	30	78	94
2.5	45	78	94
5.0	60	94	113
8.7	75	141	169
15	110	203	244	110	132
23	150	266	319	145	174
34.5	200	375	450	190	228
46	250	469	563	225	270
69	350	688	825	315	378
115	550	480	575
138	650	560	672
161	750	648	780
230	1050	925	1110

*Based on recommendations by Halperin and Shanklin.²²

Circuit: Four paralleled cables similar to the three-conductor belted cable described in Example 1, and arranged in a duct bank as illustrated in Fig. 18.

Problem: To find the overall zero-sequence impedance of the circuit, with sheaths and ground in parallel, or with return current only in the sheaths.

GMR of three conductors,
GMR_{3c} = 0.338 inches (from example 1).

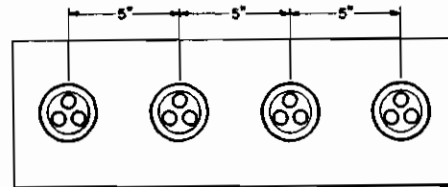

(a) Cable configuration.

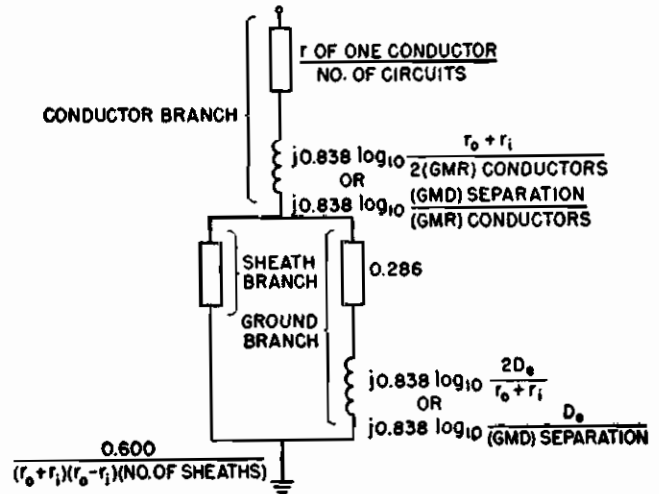

(b) General equivalent circuit.

Fig. 18—Four three-conductor cables in a duct bank (see Example 5).

GMR of the four conductor groups,

$$GMR_{4g} = \sqrt[16]{(0.338)^4(5)^6(10)^4(15)^2} = 3.479 \text{ inches.}$$

Equivalent spacing of three conductors to their sheath,

$$S_{eq} = \frac{r_1 + r_o}{2} = 0.812 \text{ inches.}$$

GMD among the conductors and the sheaths,

$$GMD_{(4g-4s)} = \sqrt[16]{(0.812)^4(5)^6(10)^4(15)^2} = 4.330 \text{ inches.}$$

From Fig. 18(b), resistance of the sheath branch,

$$\frac{0.600}{(1.623)(0.109)(4)} = 0.848 \text{ ohms per mile.}$$

Also from Fig. 18(b), impedance of the ground branch

$$= 0.286 + j0.838 \log_{10} \frac{2800 \times 12}{4.330}$$

$$= 0.286 + j3.260 \text{ ohms per mile.}$$

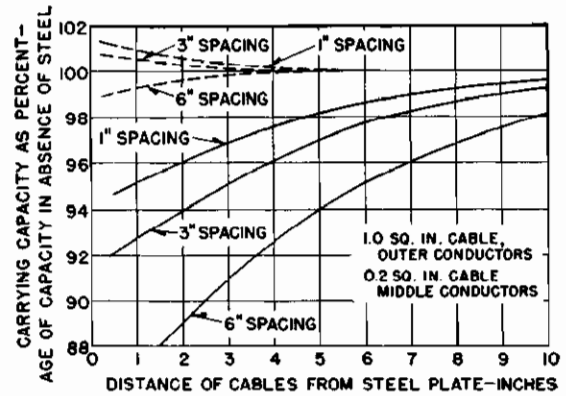

Fig. 19—Effect of steel plates on current-carrying capacity of single-conductor cables. Three phase system; flat configuration.

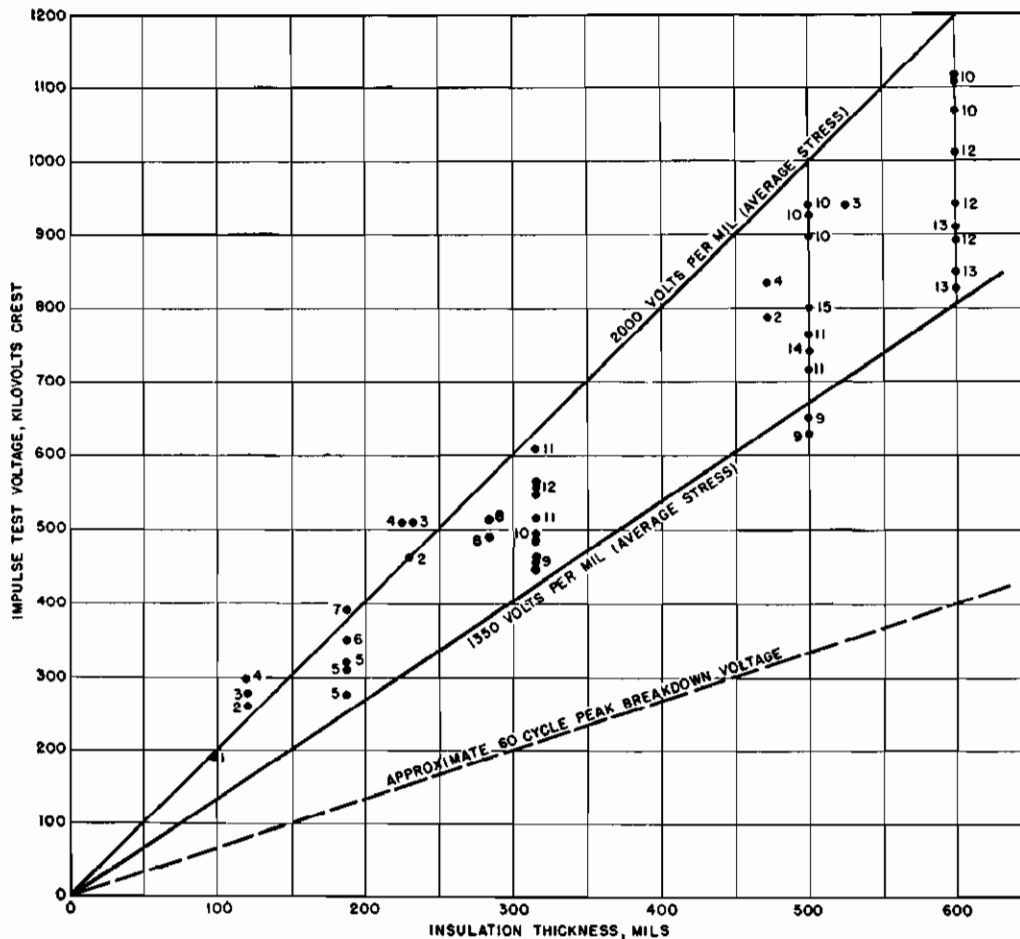

Fig. 20—Summary of some impulse tests on paper-insulated cables (based on information presented by Foust and Scott¹³).

Key:

- 1 Davis and Eddy,¹² 1 x 10 negative wave, high density paper, solid insulation (Simplex Wire and Cable Co.).
- 2 Held and Leichsenring,¹⁷ negative wave, solid insulation.
- 3 Held and Leichsenring, positive and negative waves, oil-filled insulation.
- 4 Held and Leichsenring, positive wave, solid insulation.
- 5 An unpublished test, regular density paper, oil-filled insulation (General Cable Corporation).
- 6 Foust and Scott, average of five tests, 1 x 10 positive wave, regular density paper, solid insulation (General Electric Co.).
- 7 An unpublished test, high density paper, oil-filled insulation (General Cable Corporation).
- 8 An unpublished test, solid insulation (The Okonite Company).
- 9 Foust and Scott, 1.5 x 40 positive wave, regular density paper, solid insulation.
- 10 Foust and Scott, combination regular and medium density paper, solid insulation.
- 11 Foust and Scott, high density paper, solid insulation.
- 12 Foust and Scott, medium density paper, solid insulation.
- 13 Foust and Scott, 1.5 x 40 positive wave, combination regular and medium density paper, solid insulation.
- 14 Foust and Scott, 0.5 x 40 positive wave, regular density paper, solid insulation.
- 15 Foust and Scott, 0.5 x 5 positive wave, regular density paper, solid insulation.

The zero-sequence impedance with sheath and ground in parallel,

$$Z_0 = \frac{0.848(0.286 + j3.260)}{0.848 + (0.286 + j3.260)} + 0.247 + j0.0797$$

$$= 1.022 + j0.275 \text{ ohms per phase per mile.}$$

The absolute value of this impedance is 1.06 ohms per phase per mile.

The zero-sequence impedance considering all return current in the sheath and none in the ground,

$$Z_0 = (0.247 + j0.0797) + 0.848$$

$$= 1.095 + j0.0797 \text{ ohms per phase per mile.}$$

The absolute value of this impedance is 1.1 ohms per phase per mile, or substantially the same as with the sheath and ground in parallel. In this case the effect of high sheath resistance is minimized by the fact that four sheaths are paralleled.

V. IMPULSE STRENGTH OF CABLES

Power-transmission circuits are often made up of cables and overhead-line sections connected in series, and this construction may impose lightning-surge voltages on the cable insulation. Even when circuits are totally underground, it is possible that cable insulation will be stressed by transient overvoltages caused by switching operations. For these reasons the impulse strength of cable insulation is information of some value for predicting cable performance in an actual installation.

No industry-wide standards have been established for cable impulse strength. Test data from various sources is available,^{12,13} and some of these results for paper-insulated cables are shown in Fig. 20. Several variables are inherent in the curves, so that the spread of the test points is wider than might be obtained with uniformly controlled test conditions. The factors not yet completely investigated include the effect of normal insulation aging, the relation between actual voltage gradient within the insulation and the average gradient, wave shape and polarity of the test impulse voltage, and grade or compounding of insulation.

Using 1200 volts per mil average stress as a safe withstand impulse strength for paper-insulated cables, as suggested by Halperin and Shanklin,¹⁸ the withstand voltages for representative cables may be listed as in Table 20.

REFERENCES

1. Calculation of the Electrical Problems of Underground Cables, by D. M. Simmons, *The Electric Journal*, Vol. 29, May to November, 1932. (The first article in this series contains a comprehensive bibliography for 1932 and before.)
2. *Symmetrical Components* by C. F. Wagner and R. D. Evans (a book), McGraw-Hill Book Company, 1933.
3. *The Transmission of Electric Power*, Vols. I and II, by W. A. Lewis (a book), Illinois Institute of Technology, 1948.
4. Current-Rating and Impedance of Cables in Buildings and Ships, by H. C. Booth, E. E. Hutchings, and S. Whitehead, *I.E.E. Journal*, Vol. 83, October 1938, p. 497.
5. Problems in the Measurement of A-C Resistance and Reactance of Large Conductors, by E. H. Salter, *A.I.E.E. Transactions*, Vol. 67, 1948, pp. 1390-1396.

6. A-C Resistance of Large Size Conductors in Steel Pipe or Conduit, by R. J. Wiseman, *A.I.E.E. Transactions*, Vol. 67, 1948, pp. 1745-1758.
7. Reactance of Large Cables in Steel Pipe or Conduit by W. A. Del Mar, *A.I.E.E. Transactions*, Vol. 67, 1948, pp. 1409-1412.
8. Unbalanced Currents in Cable Groups, by C. F. Wagner and H. N. Muller, Jr., *The Electric Journal*, Vol. 35, October 1938, p. 390.
9. Zero-Sequence Impedances of Parallel Three-Conductor Cables, by R. C. Cheek, *Electric Light and Power*, October 1948, p. 74.
10. The Temperature Rise of Cables in a Duct Bank, by J. H. Neher, A.I.E.E. Technical Paper 49-134, April 1949.
11. Determination of Cable Temperature by Means of Reduced Scale Models, by Andrew Gemant and Joseph Sticher, *A.I.E.E. Transactions*, Vol. 65, 1946, pp. 475-482.
12. Impulse Strength of Cable Insulation by E. W. Davis and W. N. Eddy, *A.I.E.E. Transactions*, Vol. 59, July 1940, p. 394.
13. Some Impulse-Voltage Breakdown Tests on Oil-Treated Paper-Insulated Cables, by C. M. Foust and J. A. Scott, *A.I.E.E. Transactions*, Vol. 59, July 1940, p. 389.
14. Impedance of Three-Phase Secondary Mains in Nonmetallic and Iron Conduits, by L. Brieger, E.E.I. Bulletin, February 1938.
15. Specifications for Impregnated Paper-Insulated Lead-Covered Cable: "Solid" Type (7th and 8th editions), "Oil-Filled" Type (4th edition), "Low-Pressure Gas-Filled" Type (1st edition), prepared by Association of Edison Illuminating Companies.
16. Current Carrying Capacity of Impregnated Paper, Rubber, and Varnished Cambric Insulated Cables (1st edition), compiled by The Insulated Power Cable Engineers Association, Publication No. P-29-226.
17. The Behavior of High Tension Cable Installations Under the Effect of Voltage Impulses, by C. H. Held and H. W. Leichsenring. Paper No. 207, C.I.G.R.E., Paris, June-July 1939.
18. Impulse Strength of Insulated-Power-Cable Circuits, by Herman Halperin and G. B. Shanklin, *A.I.E.E. Transactions*, Vol. 63, 1944, p. 1190.

Books

40. *Electric Cables*, by W. A. Del Mar, McGraw-Hill Book Company, 1924.
 41. *Electrical Characteristics of Transmission Circuits*, by William Nesbit, Westinghouse Technical Night School Press, East Pittsburgh, Pa., 3rd edition, 1926.
 42. *Underground Systems Reference Book*, NELA Publication No. 050, 1931.
 43. *Symmetrical Components*, by C. F. Wagner and R. D. Evans McGraw-Hill Book Company, 1933.
 44. *Impregnated Paper Insulation*, by J. B. Whitehead, John Wiley & Sons, 1935.
 45. *Electric Power Transmission and Distribution*, by L. F. Woodruff, John Wiley & Sons, 1938.
 46. *The Principles of Electric Power Transmission*, by H. Waddicor, Chapman & Hall, 1939.
 47. *The Transmission of Electric Power*, Vols. I and II, by W. A. Lewis, Illinois Institute of Technology, 1948.
- ### Impedance and Capacitance
60. Formulas and Tables for the Calculation of Mutual and Self-Inductance, Messrs. Rosa and Glover, Bureau of Standards Scientific Papers, No. S169, 1916; also No. S320, 1918.
 61. Proximity Effect in Cable Sheaths, Dwight, *A.I.E.E. Transactions*, September, 1931, p. 993.
 62. Calculation of the Electrical Problems of Underground Cables, by D. M. Simmons, *The Electric Journal*, Vol. 29, May, June, July, October and November 1932, pp. 237, 283, 337, 476, and 527.
 63. Calculations of Inductance and Current Distribution in Low-Voltage Connections to Electric Furnaces, by C. C. Levy, *A.I.E.E. Transactions*, Vol. 51, December 1932, p. 903.

64. Resistance and Reactance of Three-Conductor Cables, by E. H. Salter, G. B. Shanklin, and R. J. Wiseman, *A.I.E.E. Transactions*, Vol. 53, December 1934, p. 1581.
65. Impedance Measurements on Underground Cables, by R. I. Webb and O. W. Manz, Jr., *A.I.E.E. Transactions*, Vol. 55, April 1936, p. 359.
66. Impedance of Three-Phase Secondary Mains in Nonmetallic and Iron Conduits, by L. Brieger, E.E.I. Bulletin, February 1938.
67. Unbalanced Currents in Cable Groups, by C. F. Wagner and H. N. Muller, Jr., *The Electric Journal*, Vol. 35, October 1938, p. 390.
68. Current-Rating and Impedance of Cables in Buildings and Ships, by H. C. Booth, E. E. Hutchings, and S. Whitehead, *I.E.E. Journal*, Vol. 83, October 1938, p. 497.
69. Problems in the Measurement of A-C Resistance and Reactance of Large Conductors, by E. H. Salter, *A.I.E.E. Transactions*, Vol. 67, 1948, p. 1390.
70. Reactance of Large Cables in Steel Pipe or Conduit, by W. A. Del Mar, *A.I.E.E. Transactions*, Vol. 67, 1948, p. 1409.
71. A-C Resistance of Large Size Conductors in Steel Pipe or Conduit, by R. J. Wiseman, *A.I.E.E. Transactions*, Vol. 67, 1948, p. 1745.
72. Zero-Sequence Impedances of Parallel Three-Conductor Cables, by R. C. Cheek, *Electric Light and Power*, October 1948, p. 74.
73. A-C Resistance of Segmental Cables in Steel Pipe, by L. Meyerhoff and G. S. Eager, Jr., *A.I.E.E. Transactions*, Vol. 68, 1949, p. 816.
74. Transpositions and the Calculation of Inductance from Geometric Mean Distances, by W. B. Boast, *A.I.E.E. Transactions*, Vol. 69, Part II, 1950, p. 1531.
- Load Rating and Heating*
100. Temperatures in Electric Power Cables Under Variable Loading, by E. A. Church, *A.I.E.E. Transactions*, September, 1931, p. 982.
101. Calculation of the Electrical Problems of Underground Cables, by D. M. Simmons. *The Electric Journal*, Vol. 29, August and September 1932, pp. 395 and 423.
102. Thermal Transients and Oil Demands in Cables, by K. W. Miller and F. O. Wollaston, *A.I.E.E. Transactions*, March 1933, Vol. 52, p. 98.
103. Economical Loading of Underground Cables, by E. A. Church, *A.I.E.E. Transactions*, Vol. 54, November 1935, p. 1166.
104. Current-Rating and Impedance of Cables in Buildings and Ships, by H. C. Booth, E. E. Hutchings, and S. Whitehead, *I.E.E. Journal*, Vol. 83, October 1938, p. 497.
105. Maximum Safe Operating Temperatures for 15 kv Paper-Insulated Cables, by C. W. Franklin and E. R. Thomas, *A.I.E.E. Transactions*, October 1939, Vol. 58, p. 556.
106. Load Ratings of Cable, by Herman Halperin, *A.I.E.E. Transactions*, Vol. 58, October 1939, p. 535.
107. Economical Loading of High-Voltage Cables Installed in Underground Subway Systems, by E. R. Thomas, *A.I.E.E. Transactions*, 1939, Vol. 58, p. 611.
108. Load Ratings of Cable-II, by Herman Halperin, *A.I.E.E. Transactions*, Vol. 61, p. 931, 1942.
109. Guide for Wartime Conductor Temperatures for Power Cable in Service (committee report), *A.I.E.E. Transactions*, Vol. 63, September 1943, p. 606.
110. Current Carrying Capacity of Impregnated Paper, Rubber, and Varnished Cambric Insulated Cables (1st edition), compiled by The Insulated Power Cable Engineers Association, Publication No. P-29-226, 1943.
111. Determination of Cable Temperature by Means of Reduced Scale Models, by Andrew Gemant and Joseph Sticher, *A.I.E.E. Transactions*, Vol. 65, 1946, p. 475.
112. Thermal Characteristics of a 120 kv High-Pressure, Gas-Filled Cable Installation, by W. D. Sanderson, Joseph Sticher, and M. H. McGrath, *A.I.E.E. Transactions*, Vol. 67, Part I, 1948, p. 487.
113. The Temperature Rise of Buried Cables and Pipes, by J. H. Neher, *A.I.E.E. Transactions*, Vol. 68, Part I, 1949, p. 9.
114. The Temperature Rise of Cables in a Duct Bank, by J. H. Neher, *A.I.E.E. Transactions*, Vol. 68, Part I, 1949, p. 541.
115. Transient Temperature Phenomena of 3-Conductor Cables, by F. O. Wollaston, *A.I.E.E. Transactions*, Vol. 68, Part II, 1949, p. 1284.
116. The Thermal Resistance Between Cables and a Surrounding Pipe or Duct Wall, by F. H. Buller and J. H. Neher, *A.I.E.E. Transactions*, Vol. 69, Part I, 1950, p. 342.
117. Heat Transfer Study on Power Cable Ducts and Duct Assemblies, by P. Greebler and G. F. Barnett, *A.I.E.E. Transactions*, Vol. 69, Part I, 1950, p. 357.
- Insulation*
140. The Behavior of High Tension Cable Installations Under the Effect of Voltage Impulses, by C. H. Held and H. W. Leichsenring. Paper No. 207, C.I.G.R.E. Paris, June-July, 1939.
141. Impulse Strength of Cable Insulation by E. W. Davis and W. N. Eddy, *A.I.E.E. Transactions*, Vol. 59, July 1940, p. 394.
142. Some Impulse-Voltage Breakdown Tests on Oil-Treated Paper-Insulated Cables, by C. M. Foust and J. A. Scott, *A.I.E.E. Transactions*, Vol. 59, July 1940, p. 389.
143. Impulse Strength of Insulated-Power-Cable Circuits, by Herman Halperin and G. B. Shanklin, *A.I.E.E. Transactions*, Vol. 63, 1944, p. 1190.
144. Power Factor Measurements on Poly-phase and Multiconductor Cable Using Single-Phase Bridges, by E. W. Greenfield, *A.I.E.E. Transactions*, Vol. 69, Part II, 1950, p. 680.
- General*
150. Characteristics of Oil-filled Cable, Shanklin and Buller, *A.I.E.E. Transactions*, December, 1931, p. 1411.
151. Oil-filled Cable and Accessories, Atkinson and Simmons, *A.I.E.E. Transactions*, December, 1931, p. 1421.
152. 120 kv Compression-Type Cable, by I. T. Faucett, L. I. Komives, H. W. Collins, and R. W. Atkinson, *A.I.E.E. Transactions*, Vol. 61, September 1942, p. 652.
153. 120 kv High-Pressure Gas-Filled Cable, by I. T. Faucett, L. I. Komives, H. W. Collins, and R. W. Atkinson, *A.I.E.E. Transactions*, Vol. 61, September 1942, p. 658.
154. Low-, Medium-, and High-Pressure Gas-Filled Cable, by G. B. Shanklin, *A.I.E.E. Transactions*, Vol. 61, October 1942, p. 719.
155. Cable for Power Transmission and Distribution, by C. T. Hatcher, *Electric Light and Power*, September 1946, p. 38, and October 1946, p. 72.
156. High-Pressure, Gas-filled Cable Impregnated with Extra-High Viscosity Oil, by Joseph Sticher, G. H. Doan, R. W. Atkinson, and Louis Meyerhoff, *A.I.E.E. Transactions*, Vol. 68, Part I, 1949, p. 336.
157. Specifications for Wire and Cable with Rubber and Rubber-Like Insulations, 1st edition, 1946, prepared by Insulated Power Cable Engineers Association.
158. Specifications for Varnished Cambric Insulated Cable, 5th edition, 1946, prepared by Insulated Power Cable Engineers Association.
159. Specifications for Impregnated Paper-Insulated Lead-Covered Cable: "Solid" Type (7th and 8th editions, 1947), "Oil-Filled" Type (4th edition, 1947), "Low-Pressure Gas-Filled" Type (1st edition, 1948), prepared by Association of Edison Illuminating Companies.
- Bibliographies*
180. Calculation of the Electrical Problems of Underground Cables, by D. M. Simmons, *The Electric Journal*, Vol. 29, May 1932, p. 237.
181. Underground Systems Reference Book, NELA Publication No. 050, 1931, Appendix II.
182. Rating of Cables in Relation to Voltage, (Bibliography on Dielectrics) by D. M. Simmons, *A.I.E.E. Transactions*, Vol. 41, 1922, p. 601.

CHAPTER 5

POWER TRANSFORMERS AND REACTORS

Original Authors:

J. E. Hobson and R. L. Witzke

Revised by:

R. L. Witzke and J. S. Williams

IN this chapter are included the fundamental theory, operating practices, pertinent application data, and some of the physical characteristics of power transformers and reactors. No attempt is made to give a complete exposition of the material. It is expected that the listed references will be consulted for a more detailed consideration of each section. Although the fundamental theory presented here holds also for distribution transformers, the standards of operation and present practices regarding distribution transformer application are not included in this chapter. Grounding transformers are included since they are ordinarily associated with power systems.

I. THEORY

1. Fundamental Considerations

Before going into the various problems involved in the application of transformers and the methods used in analyzing their effect on system operation, it is well to review briefly the fundamental theory of transformer action.

Two windings on a common magnetic core are pictured in Fig. 1. Let the number of turns in the P winding be n_1 ,

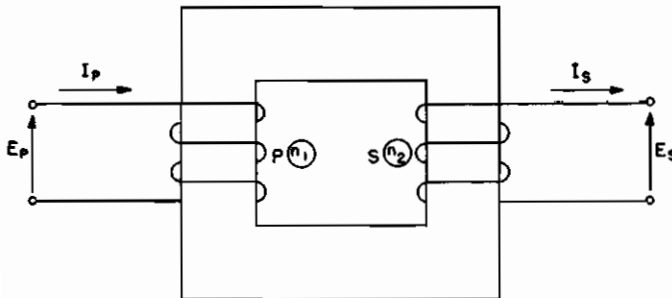

Fig. 1—Two-winding transformer.

and the number of turns in the S winding be n_2 . Assume that there is a flux in the core which links both windings and is a sinusoidal function of time.

$$\phi = \phi_{\max} \sin \omega t \quad (1)$$

Then the voltage induced in the P winding at any instant by the flux is

$$\begin{aligned} e_p &= -n_1 \frac{d\phi}{dt} \times 10^{-8} \text{ volts} \\ &= -n_1 \omega \phi_{\max} \cos \omega t \times 10^{-8} \text{ volts} \end{aligned} \quad (2)$$

where $\omega = 2\pi f$

hence, $e_p = -2\pi f n_1 \phi_{\max} \cos \omega t \times 10^{-8}$ volts

and the rms value of this voltage is

$$\begin{aligned} E_p &= \frac{2\pi f}{\sqrt{2}} n_1 \phi_{\max} \times 10^{-8} \text{ volts} \\ &= 4.44 f n_1 A B_{\max} \times 10^{-8} \text{ volts} \end{aligned} \quad (3)$$

where,

f = frequency in cycles per second.

A = cross sectional area of magnetic circuit in square centimeters (assumed uniform).

B_{\max} = maximum flux density in the core in lines per square centimeter.

Similarly, the rms voltage induced in the S winding by the flux is given by

$$E_s = 4.44 f n_2 A B_{\max} \times 10^{-8} \text{ volts.} \quad (4)$$

Thus it is evident that a sinusoidal flux linking a coil induces in it a voltage which is also sinusoidal and which lags the flux by 90 electrical degrees.

To apply the above principle to the operation of a transformer, refer again to Fig. 1 and consider the S winding as open and let a sinusoidal voltage be impressed on the P winding. The current, I_e , that flows in the P winding under this condition ($I_s = 0$) is called the exciting current and sets up an alternating flux about that winding, which consists of two parts: a mutual flux whose path is wholly in the core and which, therefore, links both windings, and a leakage flux whose path is partly in air and which links only the P winding. The ratio of the leakage flux to the mutual flux depends on the relative reluctance of their respective paths, which in turn is a function of the saturation of the core and the magnitude of the current. It is convenient to consider the voltage induced in the P winding, by the flux linking it, as made up of two components, one produced by the linkages resulting from the mutual flux and the other produced by leakage flux. In the ordinary commercial transformer the leakage flux is small and can be neglected for the present. Then, if the small iR drop in the winding is also ignored, the voltage induced in the P winding by the mutual flux can, with close approximation, be set equal and opposite to the impressed voltage. If, as assumed, the latter is sinusoidal, then the mutual flux must also be sinusoidal and the induced voltage is given by Eq. (3),

$$E_p = 4.44 f n_1 A B_{\max} \times 10^{-8} \text{ volts.}$$

By hypothesis, all of the mutual flux which has just been considered in connection with the P winding must also link the S winding. Hence, a voltage is induced in the S winding, which is expressed by Eq. (4),

$$E_s = 4.44 f n_2 A B_{\max} \times 10^{-8} \text{ volts.}$$

If the circuit connected to the S winding is closed, a current, I_s , flows and, in the manner already described in connection with the P winding, sets up a mutual and leakage flux about the winding. The direction of this current is such that the mutual flux produced by it opposes that produced by the P winding and it, therefore, tends to nullify the flux in the core. Consideration of the energies involved shows that an additional component, I_p' , must be added to the current in the P winding before the S winding is closed, such that the magnetomotive force acting on the magnetic circuit remains unchanged after S is closed. In other words, the resultant flux in the core produced by the combined action of the currents flowing in the P and S windings must equal the mutual flux present when the S winding is open. Therefore,

$$n_1 I_s = n_1 I_p - n_2 I_s, \quad (5)$$

remembering that the flux caused by I_s is opposite that caused by I_p , which accounts for the negative sign. In a well-designed transformer, the exciting current is small in comparison to the normal load current I_p' , hence we can assume the total current, I_p , in the P winding to be equal to I_p' and obtain

$$I_s = +\frac{n_1}{n_2} I_p. \quad (6)$$

The leakage flux produced by I_s induces a voltage in the S winding opposing that produced by the mutual flux. However, it is small as in the case of the P winding, and, if neglected along with the resistance drop, permits writing the relation between the P and S voltages as

$$E_s = +\frac{n_2}{n_1} E_p. \quad (7)$$

The seven equations developed above summarize the general relationships between the flux, the induced voltages, and the primary and secondary voltages and currents involved in transformer action. However, they are based on a number of assumptions that, in analyzing the operation of the transformer or of the system to which it is connected, cannot always be made. A more rigorous development that takes into consideration the effects of exciting current, losses, and leakage fluxes is therefore required.

Referring again to Fig. 1, and considering instantaneous currents and voltages, the classical equations for the coupled circuits are

$$\begin{aligned} e_p &= R_p i_p + L_p \frac{di_p}{dt} - M \frac{di_s}{dt} \\ e_s &= M \frac{di_p}{dt} - R_s i_s - L_s \frac{di_s}{dt} \end{aligned} \quad (8)$$

where R_p and R_s are, respectively, the effective resistances of the primary and secondary windings; L_p and L_s are the self-inductances of the primary and secondary windings; and M is the mutual inductance between the two windings. The positive direction of current flow in the two windings is taken such that the fluxes set up by the two currents will be in opposition.

The coefficients L_p , L_s , and M are not constant but vary with the saturation of the magnetic circuit¹. As previously

stated, the total flux linking either winding can be divided into two components, a leakage flux whose path is wholly or partly in air and a mutual flux most of which lies in the iron core. Furthermore, the mutual coupling between circuits must have an energy component to furnish the iron loss in the magnetic circuit. With the above considerations in mind the equivalent circuit representing the two coupled windings in Fig. 1 can be derived².

The equivalent circuit is shown in Fig. 2(a), where the mathematical artifice of an ideal transformer² is introduced to preserve actual voltage and current relationships at the terminals, and to insulate the two windings. The ideal transformer is defined as having no losses, no impedance drop, and requiring no exciting current. The ratio of transformation for the ideal transformer is N , where

$$N = \frac{n_2}{n_1}. \quad (9)$$

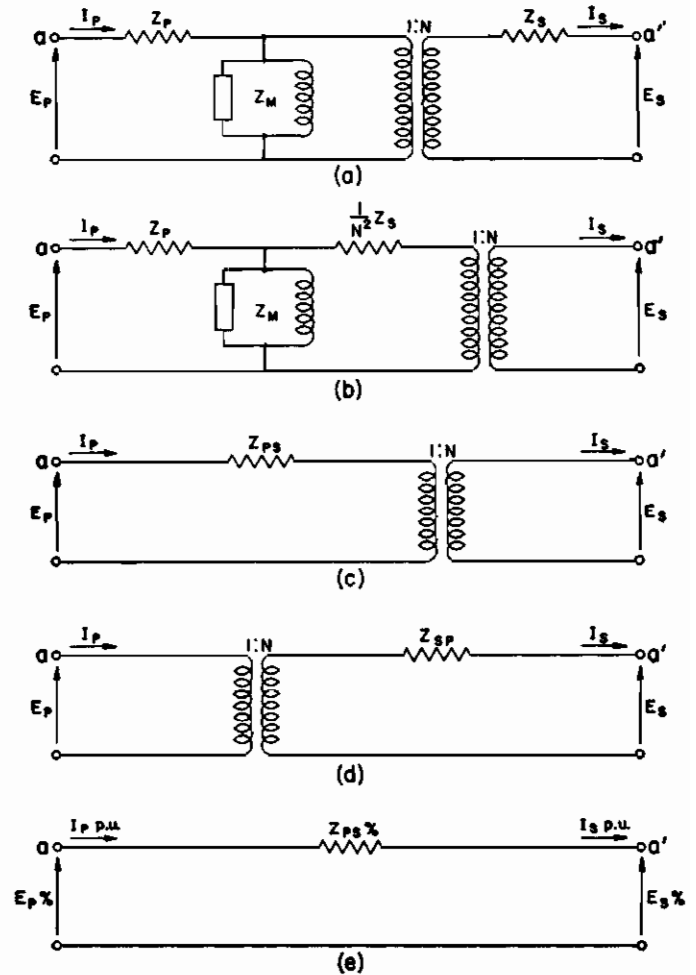

Fig. 2—Equivalent circuits for two-winding transformer.

- (a) Equivalent circuit in ohms, with magnetizing current considered.
- (b) Equivalent circuit in ohms, with all impedances on the primary voltage base.
- (c) Equivalent circuit in ohms, with the magnetizing branch neglected.
- (d) Equivalent circuit in ohms, with the leakage impedance referred to the secondary voltage base.
- (e) Equivalent circuit in percent.

The shunt resistance branch in Z_M represents the iron losses and the shunt reactive branch ($j\omega \frac{n_1}{n_2} M$) provides a path for the no load, or exciting current of the transformer. The variation in M during the cycle of instantaneous current and voltage variation is ignored, and a mean value is used. The branches, $Z_P = R_P + j\omega \left(L_P - \frac{n_1}{n_2} M \right)$ and, $Z_S = R_S + j\omega \left(L_S - \frac{n_2}{n_1} M \right)$ are essentially constant, regardless of instantaneous current variations, since their corresponding leakage fluxes lie mostly in air. Z_P and Z_S are components of the leakage impedance between the P and S windings such that

$$Z_{PS} = Z_P + \frac{1}{N^2} Z_S \quad (10)$$

Z_{PS} is defined as the leakage impedance between the P and S windings, as measured in ohms on the P winding with the S winding short-circuited. Actually it is not possible³ to segregate Z_{PS} into two parts, Z_P associated with the P winding and Z_S associated with the S winding by any method of test; for example, Z_P , the portion of Z_{PS} associated with the primary winding, varies with excitation and load conditions. It is customary, in many calculations involving the equivalent circuit, to make

$$Z_P = \frac{1}{N^2} Z_S = \frac{1}{2} Z_{PS} \quad (11)$$

The ideal transformer can be shifted to the right, as in Fig. 2(b), to get all branches of the circuit on the same voltage base. Since the impedance of the shunt branch is large compared to Z_{PS} , it can be omitted for most calculations involving transformer regulation, and the equivalent circuit becomes that of Fig. 2(c). A notable exception to those cases where the shunt branch can be disregarded is the case of the three-phase core-form transformer excited with zero-sequence voltages. This will be discussed in detail later.

The form of the equivalent circuit given in Fig. 2(c) can be changed to show the leakage impedance referred to the secondary voltage, by shifting the ideal transformer to the left, as in Fig. 2(d). For this condition Z_{SP} , the leakage impedance between the P and S windings as measured in ohms on the S winding with the P winding short-circuited, is related to Z_{PS} as follows:

$$Z_{SP} = N^2 Z_{PS} = \left(\frac{n_2}{n_1} \right)^2 Z_{PS} \quad (12)$$

The equivalent circuit using percentage impedances, percentage voltages, and currents in per unit is given in Fig. 2(e). An ideal transformer to maintain transformation ratios is not required.

2. Transformer Vector Diagram

The vector diagram illustrating the relationship between the terminal voltages, the internal induced voltages and the currents in the transformer of Fig. 1 can be drawn directly from the equivalent circuit for the transformer. This circuit is repeated in Fig. 3(a) and the various voltages

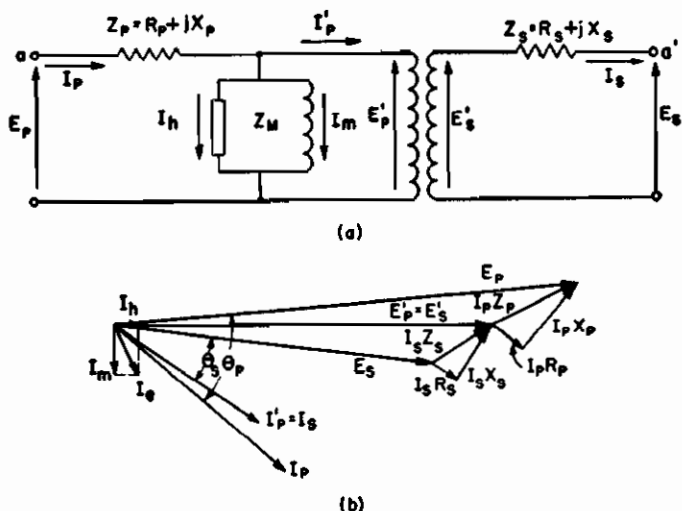

Fig. 3—Equivalent circuit and corresponding vector diagram for two-winding transformer.

and currents are identified there. The primary and secondary leakage impedances Z_P and Z_S are shown separately, and the primary and secondary resistances R_P and R_S are also indicated. I_h and I_m represent the core-loss component and the magnetizing component respectively of the exciting current I_e . The vector diagram in Fig. 3(b) is drawn for a 1:1 ratio of transformation and for a load of lagging power factor. The power-factor angles at the P winding terminals and the S winding terminals are designated in the diagram as θ_P and θ_S respectively.

II. ELECTRICAL CHARACTERISTICS

3. Transformer Impedances

The turns ratio of a two-winding transformer determines the ratio between primary and secondary terminal voltages, when the transformer load current is zero. However, when load is applied to the transformer, the load current encounters an apparent impedance within the transformer which causes the ratio of terminal voltages to depart from the actual turns ratio. This internal impedance consists of two components: (1) a reactance derived from the effect of leakage flux in the windings, and (2) an equivalent resistance which represents all losses traceable to the flow of load current, such as conductor I^2R loss and stray eddy-current loss.

Impedance drop is conveniently expressed in percent, and is the impedance-drop voltage expressed as a percentage of rated terminal voltage, when both voltages are referred to the same circuit; in three-phase transformer banks, it is usually appropriate to refer both impedance-drop voltage and rated voltage to a line-to-neutral basis. Percent impedance is also equal to measured ohmic impedance, expressed as a percentage of "normal" ohms. Normal ohms for a transformer circuit are defined as the rated current (per phase) divided into rated voltage (line-to-neutral).

Representative impedance values for distribution and power transformers are given in Table 1; for most purposes the impedances of power transformers may be considered

TABLE 1—TRANSFORMER IMPEDANCES

(a) Standard Reactances and Impedances for Ratings 500 kva and below (for 60-cycle transformers)

Single-Phase Kva Rating*	Rated-Voltage Class in kv							
	2.5		15		25		69	
	Average Reactance %	Average Impedance %	Average Reactance %	Average Impedance %	Average Reactance %	Average Impedance %	Average Reactance %	Average Impedance %
3	1.1	2.2	0.8	2.8				
10	1.5	2.2	1.3	2.4	4.4	5.2		
25	2.0	2.5	1.7	2.3	4.8	5.2		
50	2.1	2.4	2.1	2.5	4.9	5.2	6.3	6.5
100	3.1	3.3	2.9	3.2	5.0	5.2	6.3	6.5
500	4.7	4.8	4.9	5.0	5.1	5.2	6.4	6.5

*For three-phase transformers use 1/3 of the three-phase kva rating, and enter table with rated line-to-line voltages.

as equal to their reactances, because the resistance component is so small. The standard tolerances by which the impedances may vary are $\pm 7\frac{1}{2}$ percent of specified values for two-winding transformers and ± 10 percent for three-winding, auto, and other non-standard transformers.

The percent resistance of transformers is less consistent among various designs than is the impedance, and though the curves in Fig. 4 show definite values for transformer resistance, considerable deviation from these figures is possible.

Transformers can be designed to have impedances within closer tolerances than mentioned above, or impedances outside the normal range, but usually at extra cost.

A guide to the impedances of three-winding transformers is given below (this guide does not apply to auto-transformers).

(1) Select a kva base equal to the kva rating of the

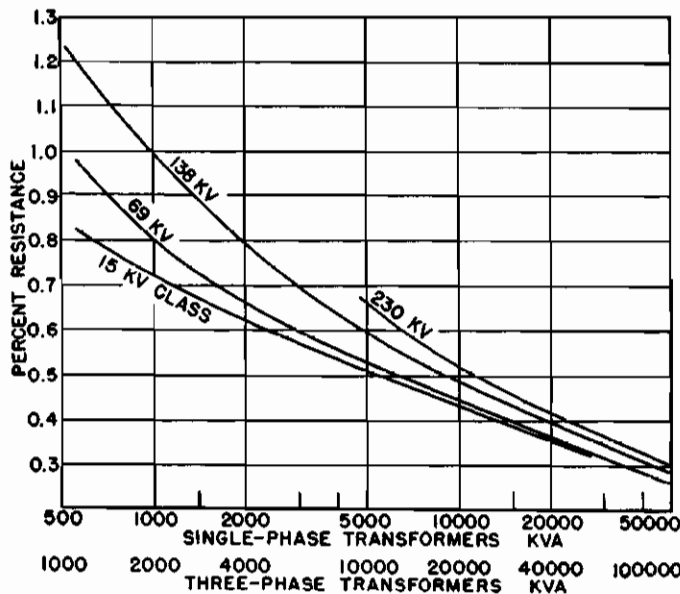

Fig. 4—Percent resistance of transformers, based on OA kva ratings.

TABLE 1—TRANSFORMER IMPEDANCES (Continued)

(b) Standard Range in Impedances for Two-Winding Power Transformers Rated at 55 C Rise (Both 25- and 60-cycle transformers)

High-Voltage Winding Insulation Class kv	Low-Voltage Winding Insulation Class kv	Impedance Limit in Percent			
		Class OA OW OA/FA* OA/FA/FOA*		Class FOA FOW	
		Min.	Max.	Min.	Max.
15	15	4.5	7.0	6.75	10.5
25	15	5.5	8.0	8.25	12.0
34.5	15	6.0	8.0	9.0	12.0
	25	6.5	9.0	9.75	13.5
46	25	6.5	9.0	9.75	13.5
	34.5	7.0	10.0	10.5	15.0
69	34.5	7.0	10.0	10.5	15.0
	46	8.0	11.0	12.0	16.5
92	34.5	7.5	10.5	11.25	15.75
	69	8.5	12.5	12.75	18.75
115	34.5	8.0	12.0	12.0	18.0
	69	9.0	14.0	13.5	21.0
	92	10.0	15.0	15.0	23.25
138	34.5	8.5	13.0	12.75	19.5
	69	9.5	15.0	14.25	22.5
	115	10.5	17.0	15.75	25.5
161	46	9.5	15.0	13.5	21.0
	92	10.5	16.0	15.75	24.0
	138	11.5	18.0	17.25	27.0
196	46	10	15.0	15.0	22.5
	92	11.5	17.0	17.25	25.5
	161	12.5	19.0	18.75	28.5
230	46	11.0	16.0	16.5	24.0
	92	12.5	18.0	18.75	27.0
	161	14.0	20.0	21.0	30.0

*The impedances are expressed in percent on the self-cooled rating of OA/FA and OA/FA/FOA

Definition of transformer classes:
 OA—Oil-immersed, self cooled OW—Oil-immersed, water-cooled.
 OA/FA—Oil-immersed, self-cooled/forced-air-cooled.
 OA/FA/FOA—Oil-immersed, self-cooled/forced-air-cooled/forced oil cooled.
 FOA—Oil-immersed, forced-oil-cooled with forced air cooler.
 FOW—Oil-immersed, forced-oil-cooled with water cooler.

Note: The through impedance of a two-winding autotransformer can be estimated knowing rated circuit voltages, by multiplying impedance obtained from this table by the factor $(\frac{HV-LV}{HV})$.

largest capacity winding, regardless of voltage rating. All impedances will be referred to this base.

(2) Select a percent impedance between the medium-voltage and the high-voltage circuits ($Z_{MH}\%$), lying between the limits shown for two-winding transformers in Table 1.

(3) The percent impedance between the medium-voltage and low-voltage circuits ($Z_{ML}\%$) may lie between the limits of 0.35 ($Z_{MH}\%$) and 0.80 ($Z_{MH}\%$). Select a value of $Z_{ML}\%$ lying within this range.

(4) Having established $Z_{MH}\%$ and $Z_{ML}\%$, the percent impedance between the high-voltage and low-voltage circuits ($Z_{HL}\%$) is determined as follows:

$$Z_{HL}\% = 1.10(Z_{MH}\% + Z_{ML}\%) \quad (13)$$

When impedances outside the above ranges are required, a suitable transformer can usually be supplied but probably at increased cost.

4. Regulation

The full load regulation of a power transformer is the change in secondary voltage, expressed in percent of rated secondary voltage, which occurs when the rated kva output

at a specified power factor is reduced to zero, with the primary impressed terminal voltage maintained constant. Percent regulation can be calculated at any load and any power factor by an approximate formula:

$$\text{Regulation} = \left[pr + qx + \frac{(px - qr)^2}{200} \right] \times \frac{\text{operating current}}{\text{rated current}} \quad (14)$$

where:

“Regulation” is a percent quantity;

r = percent resistance

$$= \frac{\text{load losses in kw, at rated kva}}{\text{rated kva}} \times 100$$

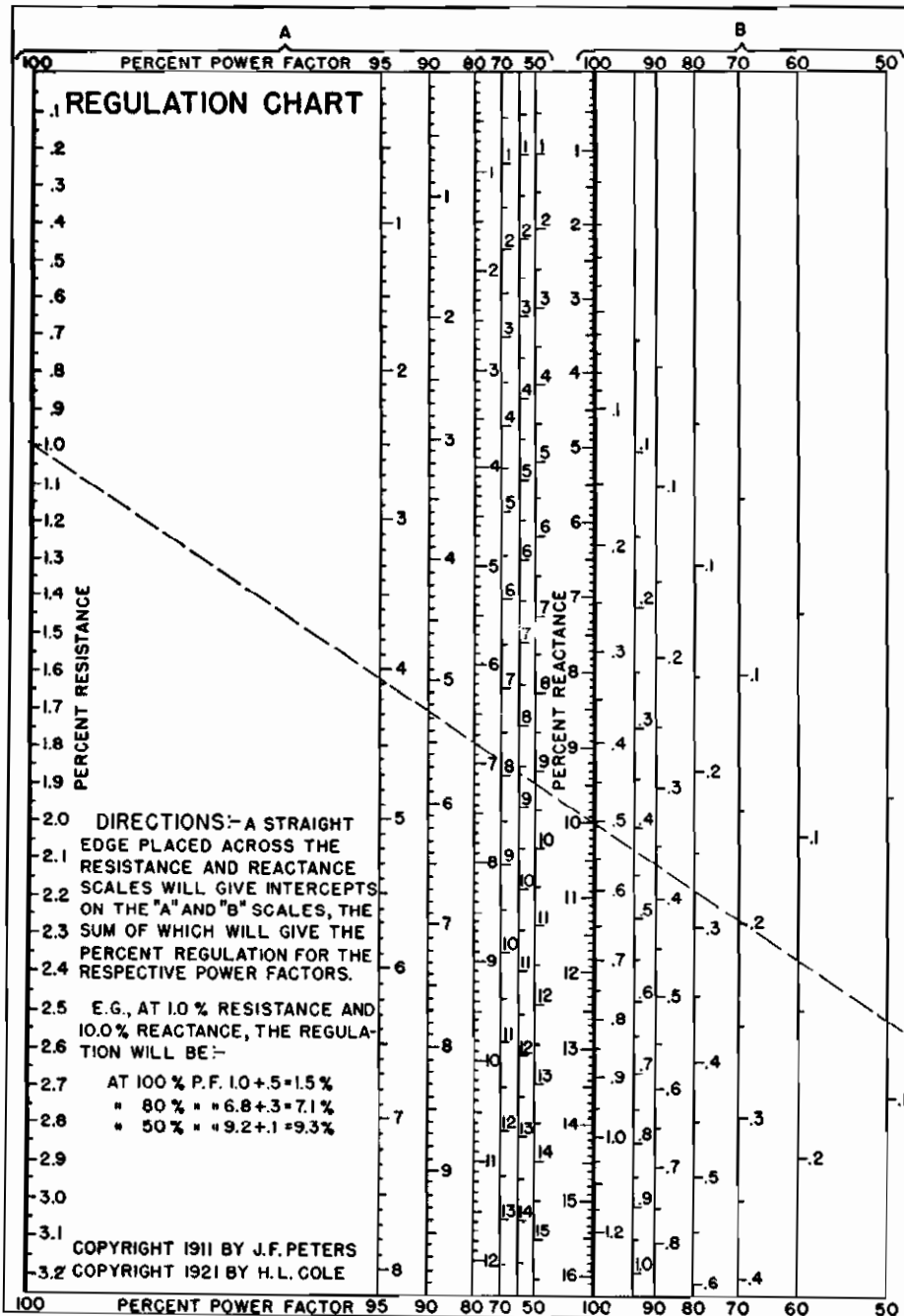

Fig. 5—Chart for calculating regulation of transformers.

$$z = \text{percent impedance} = \frac{\text{impedance kva}}{\text{rated kva}} \times 100$$

$$x = \text{percent reactance} = \sqrt{z^2 - r^2}$$

$$p = \cos \theta$$

$$q = \sin \theta$$

θ = power factor angle of load (taken as positive when current lags voltage).

The full-load regulation of a transformer can be determined for any power factor from the chart in Fig. 5; this chart is based on Eq. (14).

Typical regulation for three-phase transformers at full load and various power factors is shown in Table 2. These

TABLE 2—APPROXIMATE REGULATION FOR 60-CYCLE THREE-PHASE TYPE OA TRANSFORMERS AT FULL LOAD

Insulation Class kv	Lagging Power Factor Percent	Percent Regulation		
		1000 kva	10 000 kva	100 000 kva
15	80	4.2	3.9	
	90	3.3	3.1	
	100	1.1	0.7	
34.5	80	5.0	4.8	
	90	4.0	3.7	
	100	1.2	0.8	
69	80	6.1	5.7	5.5
	90	4.9	4.4	4.2
	100	1.4	0.9	0.6
138	80	7.7	7.2	7.0
	90	6.2	5.6	5.4
	100	1.8	1.2	0.9
230	80		9.7	9.4
	90		7.6	7.3
	100		1.7	1.3

Note: These figures apply also to OA/FA and OA/FA/FOA transformers, at loads corresponding to their OA ratings.

figures also apply, but less accurately, to transformer banks made up of three single-phase transformers; in this case the table should be entered with the three-phase bank kva rating.

The regulation of three-winding transformers can be calculated directly from transformer equivalent circuits, if the impedance branches and loading for each circuit are known. The regulation of four-winding transformers may also be calculated using formulas developed by R. D. Evans.⁴

5. Definition of Efficiency

The efficiency of a transformer, expressed in per unit, is the ratio of real power output to power input;

$$\text{Efficiency} = \frac{\text{Output}}{\text{Input}} = 1 - \frac{\text{Losses}}{\text{Input}} \quad (15)$$

Total losses are the sum of the no-load losses and load losses. No-load losses are eddy-current loss, hysteresis loss, I^2R loss caused by exciting current, and dielectric

loss; that is, all losses incident to magnetization at full voltage with the secondary circuit open. Load losses are I^2R loss caused by load current, eddy-current loss induced by stray fluxes within the transformer structure, and similar losses varying with load current.

No-load losses are measured at rated frequency and rated secondary voltage, and can be considered as independent of load. Load losses are measured at rated frequency and rated secondary current, but with the secondary short-circuited and with reduced voltage applied to the primary. Load losses can be assumed to vary as the square of the load current.

6. Methods of Calculating Efficiency

Conventional Method—This method is illustrated below for a transformer having 0.50 percent no-load loss and 1.0 percent load loss at full load. Percent no-load loss is determined by dividing the no-load loss in watts by 10 times the kva rating of the transformer, and the percent load loss (total minus no-load) is determined by dividing the load loss in watts by 10 times the kva rating of the transformer. Note that the no-load loss remains constant regardless of the load whereas the load loss varies directly as the square of the load.

Percent load.....	100.00	75.00	50.00	25.00	(1)
Percent no-load loss....	1.00	.562	.25	.062	(2)
Percent no-load loss..	.50	.50	.50	.50	(3)
Sum of (2) and (3)..	1.50	1.062	.75	.562	(4)
Sum of (1) and (4)..	101.50	76.062	50.75	25.562	(5)
Dividing 100 times					
(4) by (5).....	1.48	1.40	1.48	2.20	(6)
Subtract (6) from 100	98.52	98.60	98.52	97.80	(efficiency)

Slide-Rule Method—This method is illustrated for the same transformer.

Percent load.....	100.00	75.00	50.00	25.00	(1)
Percent no-load loss.....	.50	.50	.50	.50	(2)
Percent load loss.....	1.00	.562	.25	.062	(3)
Sum of (2) and (3).....	1.50	1.062	.75	.562	(4)
Sum of (1) and (4).....	101.50	76.062	50.75	25.562	(5)

At this point the operations are continued on the slide rule, and are described here for the full load point only:

1. Set 1.5 (sum of no-load and load losses) on *D* scale.
2. Set 101.5 over this on the *C* scale.
3. Now starting at the right end of scale *D*, read the first figure (i.e., 1) as 90, the next (i.e., 9) as 91, the next (i.e., 8) as 92, etc., until 98.52 is read under the left end (i.e., 1) of scale *C*. This 98.52 is the percent efficiency at full load.

This procedure is repeated in a similar manner for other loads.

NOTE—If the sum of the percent no-load and load loss at full load is 1 percent or less, the first figure at the right end of *D* scale (i.e., 1) is read as 99 percent and the second figure (i.e., 9) is read as 99.1, the third figure (i.e., 8) is read as 99.2, etc.

If the sum of the percent no-load and load loss is greater than 1 percent as in the case illustrated above, the right end is read as 90 percent. In calculating the values for the other points, judgment will indicate whether 90 or 99 is to be used as the first figure on the right end of scale *D*.

Chart Method—The chart in Fig. 6 may be used to calculate transformer efficiency at various loads. The procedure is described in the caption below the chart.

$$L = \sqrt{\frac{Fe}{Cu}} = \frac{1}{\sqrt{R}} \tag{17}$$

where:

L = per unit kva load at which transformer operates most efficiently.

Cu = load losses at rated load, kw.

Fe = no-load losses, kw.

R = loss ratio = $\frac{\text{load loss at rated load}}{\text{no-load loss}}$.

7. Loss Ratio and Product

Maximum operating efficiency for a transformer results when the no-load (constant) losses equal the load (variable) losses. This condition will likely occur at some load less than rated kva:

$$Cu \times L^2 = Fe \tag{16}$$

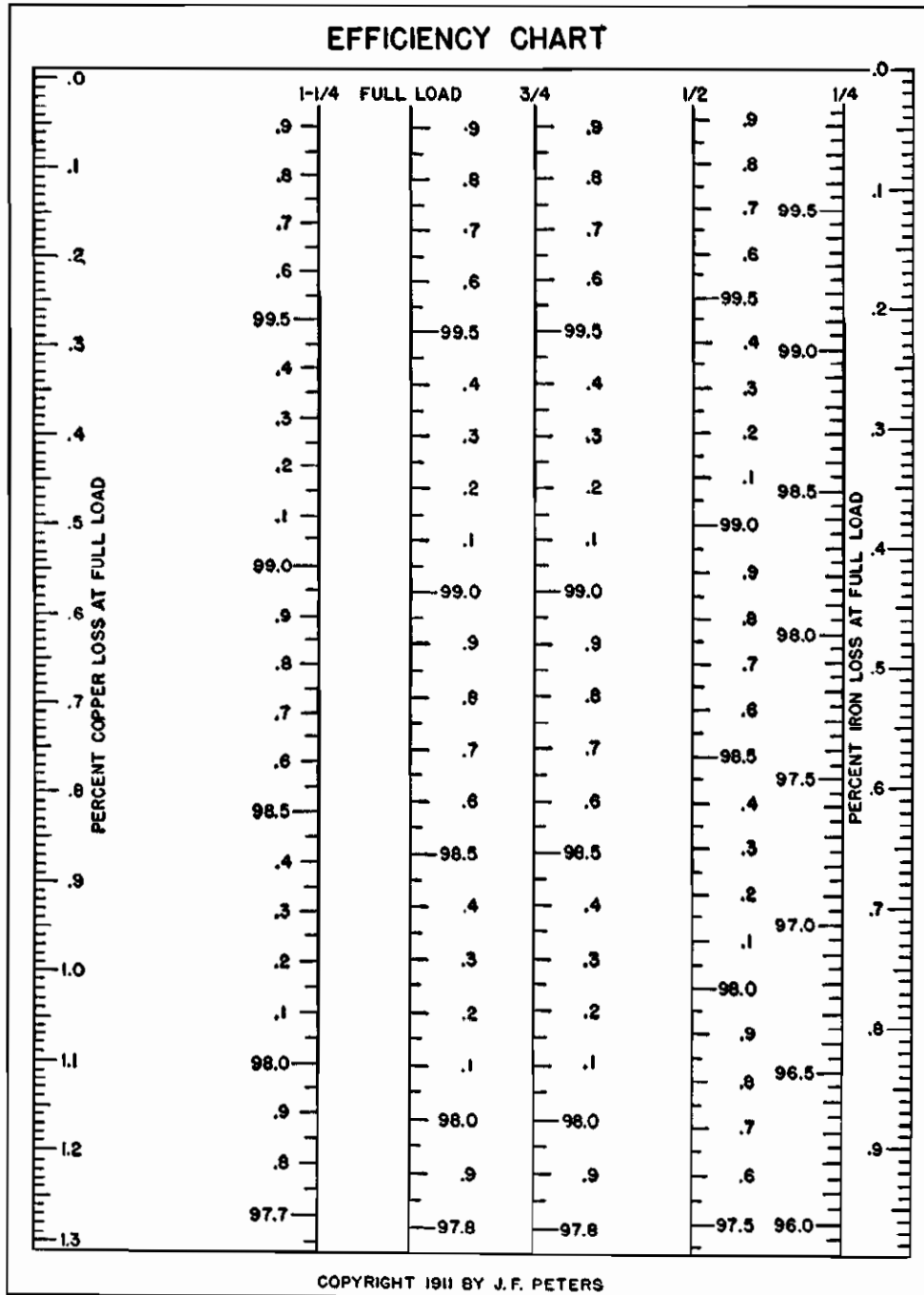

Fig. 6—Chart for calculation of efficiency. Directions: A straight-edge placed between the known full load copper loss and iron loss points will give intercepts on the efficiency scales for various loads.

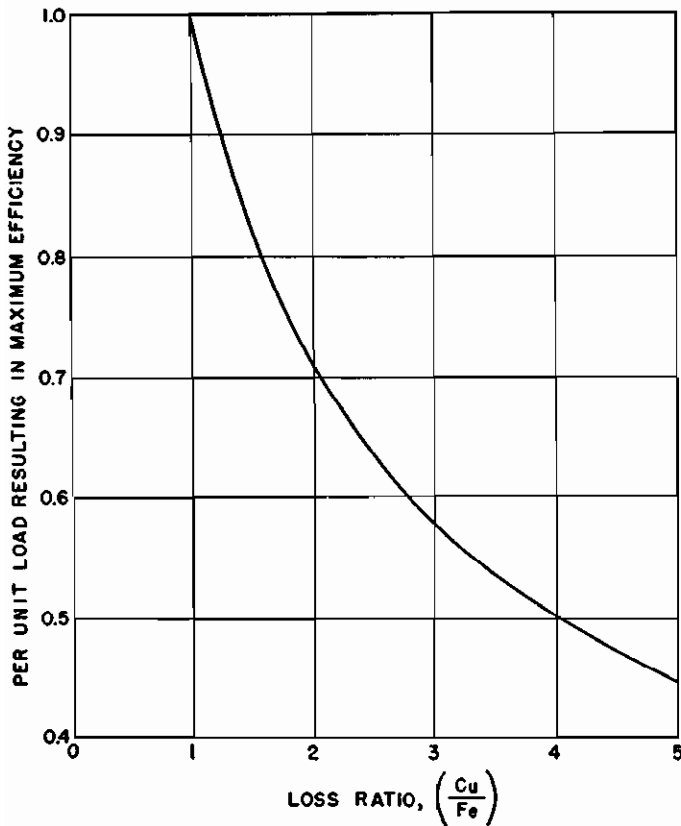

Fig. 7—Relation between transformer loss ratio and the most efficient loading.

The relation between loss ratio and most efficient transformer loading is shown in Fig. 7. The range through which loss ratio may vary in normal transformer designs is shown by Table 3.

The product of percent no-load and load losses is a quantity that has become standardized to the extent that it is predictable with fair accuracy for large power transformers.

TABLE 3
Normal Limits of Loss Ratio, R

Voltage Class kv	Loss Ratio, R = (Cu/Fe)	
	OA, OW OA/FA* OA/FA/FOA*	FOA** FOW**
46 and below.....	1.75 to 3.25	1.4 to 2.4
69 to 138, incl.....	1.50 to 2.75	1.2 to 2.0
Above 138.....	1.25 to 2.00	1.0 to 1.8

*Based on losses at OA rating.

**Based on losses at 60 percent of FOA or FOW rating.

Fig. 8 shows typical values of the product of percent losses, as a function of transformer size and voltage rating. To estimate values of no-load and load losses for a particular transformer rating it is first necessary to select values of loss ratio R and loss product P from Table 3 and Fig. 8. Then the respective loss values, in kilowatts, are given below:

$$Fe = \frac{kva}{100} \sqrt{\frac{P}{R}}, \text{ kw.} \quad (18)$$

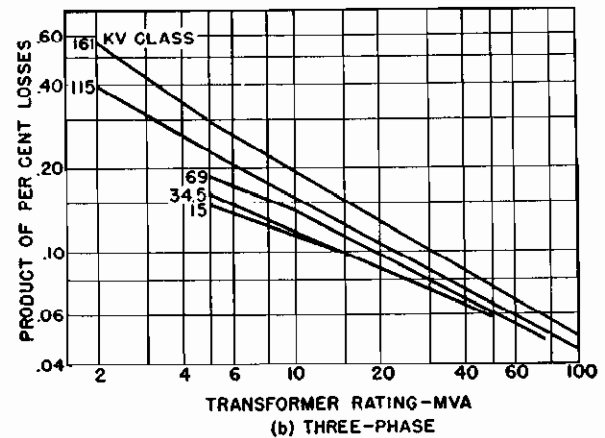
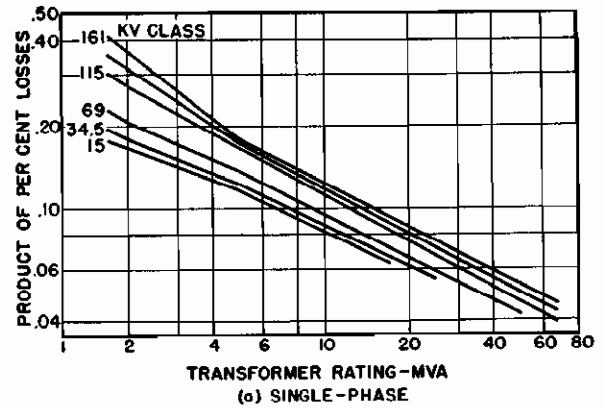

Fig. 8—Typical values of product of percent losses (percent full-load copper-loss times percent iron loss). For OA/FA or OA/FA/FOA units use OA rating to evaluate product. For FOA and FOW units use 60 percent of rated kva to evaluate product.

$$Cu = \frac{kva}{100} \times \sqrt{PR}, \text{ kw.} \quad (19)$$

where:

$$R = \text{loss ratio, } \left(\frac{Cu}{Fe}\right).$$

$$P = \text{product of the percent values of no-load and load losses, } \left(\frac{100 Fe}{kva}\right) \times \left(\frac{100 Cu}{kva}\right).$$

kva = transformer rating.

8. Typical Efficiency Values

Conventional transformer efficiency is given on the basis of losses calculated at (or corrected to) 75 degrees C and

TABLE 4—APPROXIMATE VALUES OF EFFICIENCY FOR 60-CYCLE, TWO-WINDING, OA, THREE-PHASE POWER TRANSFORMERS (Full load, unity power factor, at 75°C)

kva	Voltage Class				
	15 kv	34.5 kv	69 kv	138 kv	161 kv
2000	98.97	98.89	98.83	98.56	98.47
10 000	99.23	99.22	99.17	99.12	99.11
50 000		99.47	99.45	99.44	99.44

Note: These figures apply also to OA/FA and OA/FA/FOA transformers, at loads corresponding to their OA ratings.

unity power-factor load unless otherwise specified. Table 4 gives approximate values for 60-cycle power transformers at full load, unity power-factor, and 75 degrees C.

III. TRANSFORMER CLASSIFICATIONS

9. Forms of Construction.

Core-form construction for single-phase transformers consists of magnetic steel punchings arranged to provide a single-path magnetic circuit. High- and low-voltage coils are grouped together on each main or vertical leg of the core, as shown in Fig. 9. In general, the mean length of turn for the winding is comparatively short in the core-form design, while the magnetic path is long.

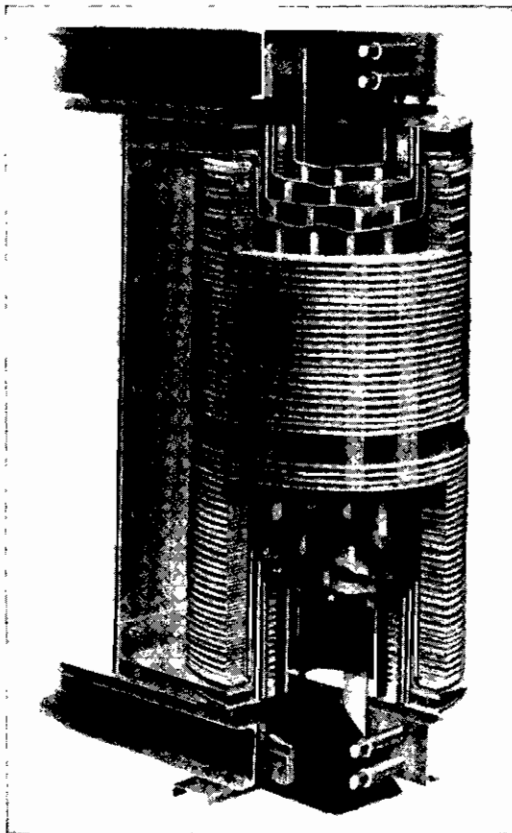
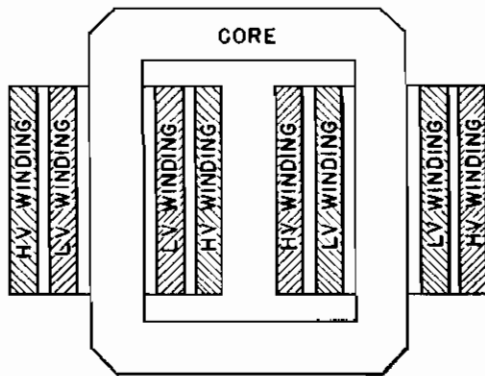

Fig. 9—Core-form construction.

Shell-form construction for single-phase transformers consists of all windings formed into a single ring, with magnetic punchings assembled so as to encircle each side of the winding ring, as in Fig. 10. The mean length of turn is usually longer than for a comparable core-form design, while the iron path is shorter.

In the design of a particular transformer many factors such as insulation stress, mechanical stress, heat distribution, weight and cost must be balanced and compromised⁶. It appears that, for well-balanced design, both core-form and shell-form units have their respective fields of applicability determined by kva and kv rating.

In the larger sizes, shell-form construction is quite appropriate; the windings and magnetic iron can be assembled

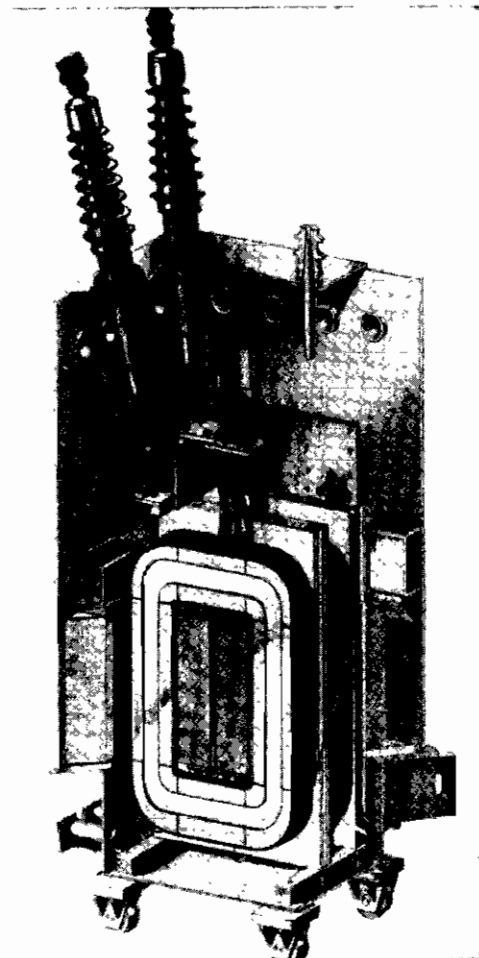
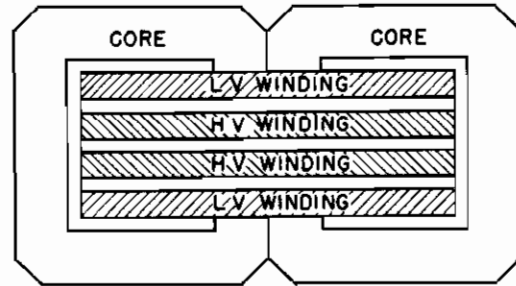

Fig. 10—Shell-form construction.

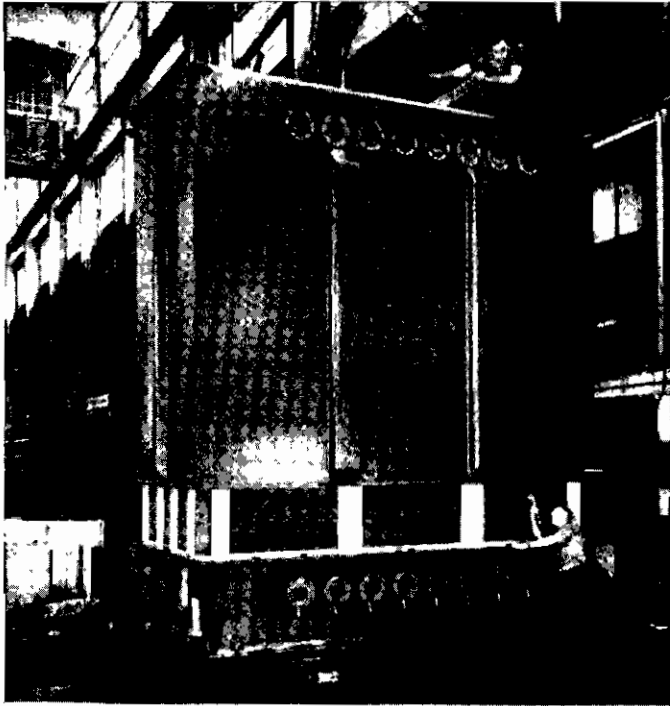

Fig. 11—Assembly of 15 000 kva three-phase transformer, showing “form-fit” tank being lowered into position.

on a steel base structure, with laminations laid in horizontally to link and surround the windings. A close-fitting tank member is then dropped over the core and coil assembly and welded to the steel base, completing the tank assembly and also securing the core to the base member. This “form-fit” construction is shown in Fig. 11; it is more compact than can be achieved by assembling a core form unit within a tank, and the flow of cooling oil can be directed more uniformly throughout the interior of the coil assembly.

10. Comparison of Single-Phase and Three-Phase Units for Three-Phase Banks

A three-phase power transformation can be accomplished either by using a three-phase transformer unit, or by interconnecting three single-phase units to form a three-phase bank. The three-phase unit has advantages of greater efficiency, smaller size, and less cost when compared with a bank having equal kva capacity made up of three single-phase units.

When three single-phase units are used in a bank, it is possible to purchase and install a fourth unit at the same location as an emergency spare. This requires only 33 percent additional investment to provide replacement capacity, whereas 100 percent additional cost would be required to provide complete spare capacity for a three-phase unit. However, transformers have a proven reliability higher than most other elements of a power system, and for this reason the provision of immediately available spare capacity is now considered less important than it once was. Three-phase units are quite generally used in the highest of circuit ratings, with no on-the-spot spare transformer capacity provided. In these cases parallel or interconnected circuits of the system may provide emergency capacity, or,

for small and medium size transformers, portable substations can provide spare capacity on short notice.

If transportation or rigging facilities should not be adequate to handle the required transformer capacity as a single unit, a definite reason of course develops for using three single-phase units.

11. Types of Cooling

Basic types of cooling are referred to by the following designations.⁶

OA—Oil-Immersed Self-Cooled—In this type of transformer the insulating oil circulates by natural convection within a tank having either smooth sides, corrugated sides, integral tubular sides, or detachable radiators. Smooth tanks are used for small distribution transformers but because the losses increase more rapidly than the tank surface area as kva capacity goes up, a smooth tank transformer larger than 50 kva would have to be abnormally large to provide sufficient radiating surface. Integral tubular-type construction is used up to about 3000 kva and in some cases to larger capacities, though shipping restrictions usually limit this type of construction at the larger ratings. Above 3000 kva detachable radiators are usually supplied. Transformers rated 46 kv and below may also be filled with Inerteen fire-proof insulating liquid, instead of with oil.

The OA transformer is a basic type, and serves as a standard for rating and pricing other types.

OA/FA—Oil-Immersed Self-Cooled/Forced-Air Cooled—This type of transformer is basically an OA unit with the addition of fans to increase the rate of heat transfer from the cooling surfaces, thereby increasing the permissible transformer output. The OA/FA transformer is applicable in situations that require short-time peak loads to be carried recurrently, without affecting normal expected transformer life. This transformer may be purchased with fans already installed, or it may be purchased with the option of adding fans later.

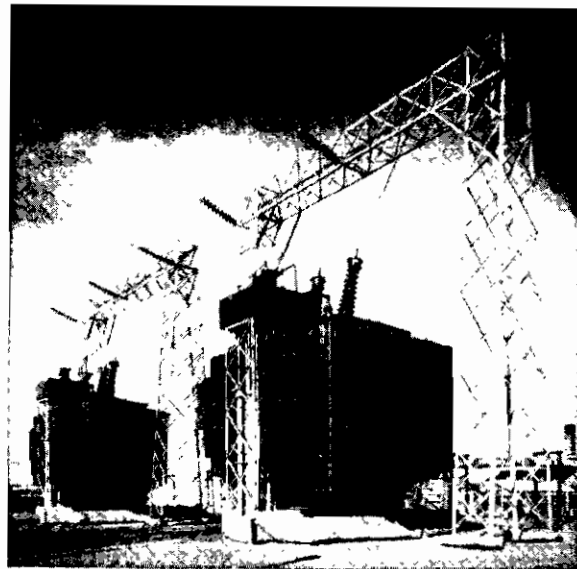

Fig. 12—Installation view of a 25 000 kva, 115-12 kv, three-phase, 60 cycle, OA/FA transformer.

The higher kva capacity attained by the use of fans is dependent upon the self-cooled rating of the transformer and may be calculated as follows:

$$\text{For 2500 kva (OA) and below:} \\ \text{kva (FA)} = 1.15 \times \text{kva(OA)}. \quad (20)$$

$$\text{For 2501 to 9999 kva (OA) single-phase or 11 999} \\ \text{kva (OA) three-phase:} \\ \text{kva (FA)} = 1.25 \times \text{kva (OA)}. \quad (21)$$

$$\text{For 10 000 kva (OA) single-phase and 12 000} \\ \text{kva (OA) three-phase, and above:} \\ \text{kva (FA)} = 1.333 \times \text{kva (OA)}. \quad (22)$$

These ratings are standardized, and are based on a hot-test-spot copper temperature of 65 degrees C above 30 degrees C average ambient.

OA/FOA/FOA—Oil-Immersed Self-Cooled/Forced-Oil Forced - Air Cooled/Forced - Oil Forced - Air Cooled—The rating of an oil-immersed transformer may be increased from its OA rating by the addition of some combination of fans and oil pumps. Such transformers are normally built in the range 10 000 kva (OA) single-phase or 12 000 kva (OA) three-phase, and above. Increased ratings are defined as two steps, 1.333 and 1.667 times the OA rating respectively. Recognized variations of these triple-rated transformers are the OA/FA/FA and the OA/FA/FOA types. Automatic controls responsive to oil temperature are normally used to start the fans and pumps in a selected sequence as transformer loading increases.

FOA—Oil-Immersed Forced-Oil-Cooled With Forced-Air Cooler—This type of transformer is intended for use only when both oil pumps and fans are operating, under which condition any load up to full rated kva may be carried. Some designs are capable of carrying excitation current with no fans or pumps in operation, but this is not universally true. Heat transfer from oil to air is accomplished in external oil-to-air heat exchangers.

OW—Oil-Immersed Water-Cooled—In this type of water-cooled transformer, the cooling water runs through coils of pipe which are in contact with the insulating oil of the transformer. The oil flows around the outside of these pipe coils by natural convection, thereby effecting the desired heat transfer to the cooling water. This type has no self-cooled rating.

FOW—Oil-Immersed Forced-Oil-Cooled With Forced-Water Cooler—External oil-to-water heat exchangers are used in this type of unit to transfer heat from oil to cooling water; otherwise the transformer is similar to the FOA type.

AA—Dry-Type Self-Cooled—Dry-type transformers, available at voltage ratings of 15 kv and below, contain no oil or other liquid to perform insulating and cooling functions.

Air is the medium which surrounds the core and coils, and cooling must be accomplished primarily by air flow inside the transformer. The self-cooled type is arranged to permit circulation of air by natural convection.

AFA—Dry-Type Forced-Air Cooled—This type of transformer has a single rating, based on forced circulation of air by fans or blowers.

AA/FA—Dry-Type Self-Cooled/Forced-Air Cooled—This design has one rating based on natural convection

and a second rating based on forced circulation of air by fans or blowers.

IV. POLARITY AND TERMINAL MARKINGS

12. Single-Phase Transformers

Primary and secondary terminals of a single-phase transformer have the same polarity when, at a given instant of time, the current enters the primary terminal in question and leaves the secondary terminal. In Fig. 13 are illustrated

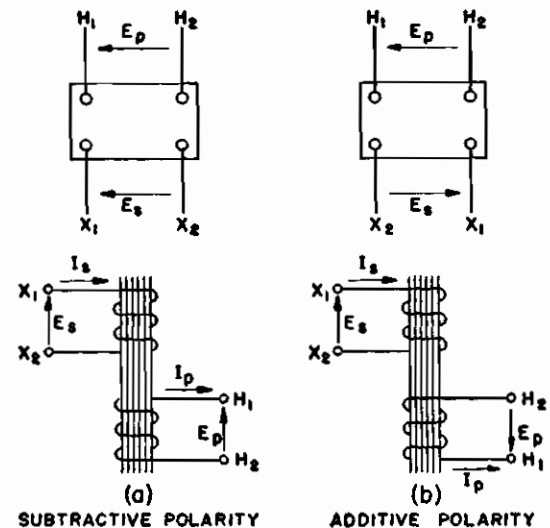

Fig. 13—Standard polarity markings for two-winding transformers.

single-phase transformers of additive and subtractive polarity. If voltage is applied to the primary of both transformers, and *adjacent* leads connected together, H_1 to X_1 in Fig. 13(a) and H_1 to X_2 in Fig. 13(b), a voltmeter across the other pair of terminals [H_2 and X_2 in Fig. 13(a) and H_2 and X_1 in Fig. 13(b)] indicates a voltage greater than E_p if the transformer is additive as Fig. 13(b), and less than E_p if the transformer is subtractive as Fig. 13(a).

Additive polarity is standard for all single-phase transformers 200 kva and smaller having high-voltage ratings 8660 volts (winding voltage) and below. Subtractive polarity is standard for all other single-phase transformers.⁶

13. Three-Phase Transformers

The polarity of a three-phase transformer is fixed by the connections between phases as well as by the relative locations of leads, and can be designated by a sketch showing lead marking and a vector diagram showing the electrical angular shift between terminals.

The standard angular displacement between reference phases of a delta-delta bank, or a star-star bank is zero degrees. The standard angular displacement between reference phases of a star-delta bank, or a delta-star bank, is 30 degrees. The present American standard for such three-phase banks is that the high-voltage reference phase is 30 degrees *ahead* of the reference phase on the low voltage, regardless of whether the bank connections are star-delta or delta-star.⁶ The standard terminal markings

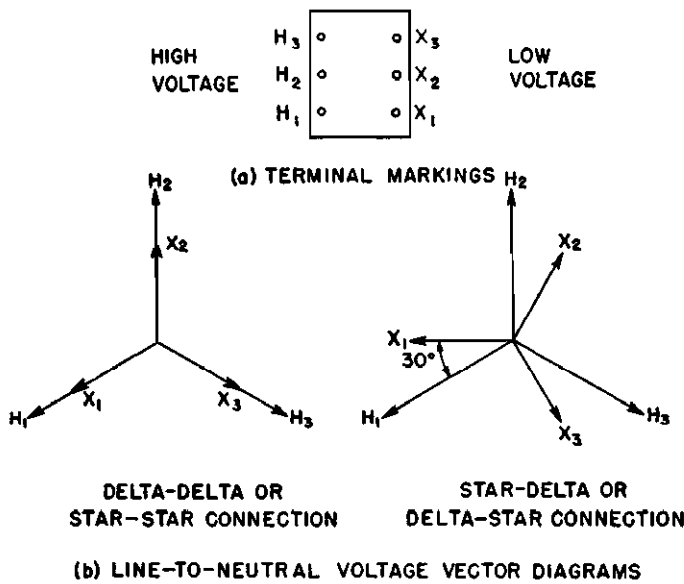

Fig. 14—Standard polarity markings and vector diagrams for three-phase transformers.

for a three-phase, two-winding transformer are illustrated in Fig. 14. Also included are the vector diagrams for delta-delta, star-star, star-delta and delta-star connected transformers. The phase rotations are assumed to be $H_1-H_2-H_3$ and $X_1-X_2-X_3$.

Fig. 15 summarizes the phase angles that can be obtained between high- and low-voltage sides of star-delta and delta-

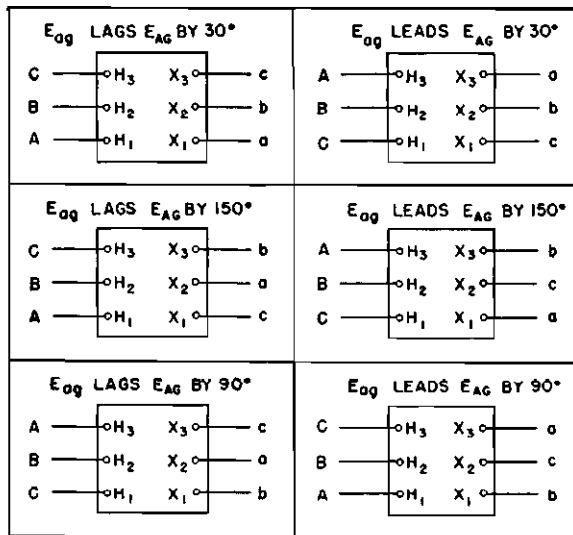

Fig. 15—Angular phase displacements obtainable with three-phase star-delta transformer units.

star, three-phase transformers built with standard connections and terminal markings. In this Figure A, B, and C represent the three phases of the high-voltage system, whereas a, b, and c represent the three phases of the low-voltage system. Phase rotations A-B-C and a-b-c are assumed.

V. STANDARD INSULATION CLASSES

14. Choice of Insulation Class

The standard insulation classes and dielectric tests for power transformers are given in Table 5. The insulation class of a transformer is determined by the dielectric tests which the unit can withstand, rather than by rated operating voltage.

On a particular system, the insulation class of the connected power transformers may be determined by the ratings and characteristics of the protective devices installed to limit surge voltages across the transformer windings. Ratings of the protective devices will in turn depend upon the type of system, its grounding connections, and some related factors. For example, when the system neutral is solidly grounded so that a grounded neutral (80 percent) arrester can be used, an insulation level corresponding to the arrester rating may be chosen rather than an insulation level corresponding to the system operating voltage. Many transformer banks having a star-connected three-phase winding, with the neutral permanently and solidly grounded, have an impulse strength corresponding to a lower line-to-line classification than indicated in Table 5 (See Chap. 18 for a more detailed discussion of this subject).

15. Dielectric Tests

The purpose of dielectric testing is to show that the design, workmanship, and insulation qualities of a transformer are such that the unit will actually meet standard or specified voltage test limits. Below is a description of the various dielectric tests which may be applied to power transformers:

(1) The *standard impulse test* consists of applying in succession, one *reduced full wave*, two *chopped waves*, and one *full wave*.

(a) A *full wave* is a 1.5×40 microsecond wave, usually of negative polarity for oil-immersed transformers, or positive polarity for dry type, and of the magnitude given in Table 5.

(b) A *reduced full wave* is a 1.5×40 microsecond wave, having a crest value between 50 and 70 percent of the full wave crest.

(c) A *chopped wave* is formed by connecting an air gap to cause voltage breakdown on the tail of the applied wave. The crest voltage and minimum time to flashover are specified in Table 5.

(2) The standard *applied-potential test* consists of applying a low-frequency voltage between ground and the winding under test, with all other windings grounded. The standard test voltage magnitude is listed in Table 5, and its specified duration is one minute.

(3) The standard *induced-potential test* in general consists of applying between the terminals of one winding a voltage equal to twice the normal operating voltage of that winding. A frequency of twice rated or more is used for this test, so that the transformer core will not be over-excited by the application of double voltage. The duration of the test is 7200 cycles of the test frequency, but not longer than one minute. Commonly used test frequencies

TABLE 5—STANDARD INSULATION CLASSES AND DIELECTRIC TESTS FOR DISTRIBUTION AND POWER TRANSFORMERS

(Taken from Table 11.030 ASA Standard C57.11-1948 for Transformers, Regulators and Reactors.)

Insulation Class kv	Rated Voltage Between Terminals of Power-Transformers (a)			Low Frequency Tests		Impulse Tests					
	Single-Phase		3-Phase	Oil-Immersed Type kv rms	Dry Type (b) kv rms	Oil-Immersed Transformers 500 kva or Less		Oil-Immersed Transformers Above 500 kva			
	For Y-Connection on 3-Phase System (c) kv rms	For Delta-Connection on 3-Phase System kv rms	Delta or Y-Connected kv rms (c)			Chopped Wave		Full Wave (e)	Chopped Wave		Full Wave (e)
				Kv Crest	Min Time to Flash-over Microsec.	Kv Crest	Kv Crest	Min Time to Flash-over Microsec.	Kv Crest		
1.2	0.69	0.69 (d)	1.2	10	4	36	1.0	30	54	1.5	45
2.5	2.5	15	10	54	1.25	45
5.0	2.89	2.89 (d)	5.0	19	12	69	1.5	60	88	1.6	75
8.66	5.0	5.00 (d)	8.66	26	19	88	1.6	75	110	1.8	95
15	8.66	15.0	15.0	34	31	110	1.8	95	130	2.0	110
25.0	14.4	25.0	25.0	50	..	175	3.0	150	175	3.0	150
34.5	19.9	34.5	34.5	70	..	230	3.0	200	230	3.0	200
46.0	26.6	46.0	46.0	95	..	290	3.0	250	290	3.0	250
69.0	39.8	69.0	69.0	140	..	400	3.0	350	400	3.0	350
92	53.1	92	92	185	..	520	3.0	450	520	3.0	450
115	66.4	115	115	230	..	630	3.0	550	630	3.0	550
138	79.7	138	138	275	..	750	3.0	650	750	3.0	650
161	93.0	161	161	325	..	865	3.0	750	865	3.0	750
196	113	196	196	395	..	1035	3.0	900	1035	3.0	900
230	133	230	230	460	..	1210	3.0	1050	1210	3.0	1050
287	166	287	287	575	..	1500	3.0	1300	1500	3.0	1300
345	199	345	345	690	..	1785	3.0	1550	1785	3.0	1550

- Notes: (a) Intermediate voltage ratings are placed in the next higher insulation class unless otherwise specified.
 (b) Standard impulse tests have not been established for dry-type distribution and power transformers. Present-day values for impulse tests of such apparatus are as follows:
 1.2 kv class, 10 kv; 2.5 class, 20 kv; 5.0 class, 25 kv; 8.66 kv class, 35 kv; 15 kv class, 50 kv. These values apply to both chopped-wave and full-wave tests.
 (c) Y-connected transformers for operation with neutral solidly grounded or grounded through an impedance may have reduced insulation at the neutral. When this reduced insulation is below the level required for delta operation, transformers cannot be operated delta-connected.
 (d) These apparatus are insulated for the test voltages corresponding to the Y connection, so that a single line of apparatus serves for the Y and delta applications. The test voltages for such delta-connected single-phase apparatus are therefore one step higher than needed for their voltage rating.
 (e) 1.5×40 microsecond wave.

are 120 cycles for 60-cycle transformers, and 60 cycles for 25-cycle transformers.

Combinations and modifications of the tests described above are contained in transformer standard publications, for example ASA C57.22-1948, and these publications should be consulted for detailed information.

16. Insulation Class of Transformer Neutrals

Transformers designed for wye connection only with the neutral brought out may have a lower insulation level at the neutral than at the line end. The following rules are included as a guide in selecting the permissible neutral insulation level:

(a) A solidly grounded transformer may have a minimum neutral insulation class in accordance with column 2 of Table 6.

(b) A transformer grounded through a neutral impedance must have a neutral insulation class at least as high as the maximum dynamic voltage at the transformer neutral during system short-circuit conditions. In no case

should the neutral class be lower than that given in Column 2, Table 6.

(c) If the neutral of a transformer is connected to ground through the series winding of a regulating transformer, the neutral insulation class must be at least as high as the maximum raise or lower voltage (phase to neutral) of the regulating transformer. In no case should the neutral class be less than that given in Column 3 of Table 6.

(d) A transformer grounded through the series winding of a regulating transformer and a separate neutral impedance shall have a neutral insulation class at least as high as the sum of the maximum raise or lower voltage (line to neutral) of the regulating transformer and the maximum dynamic voltage across the neutral impedance during system short-circuit conditions. In no case should the neutral insulation class be less than that given in Column 3 of Table 6.

(e) If the neutral of a transformer is connected to ground through a ground fault neutralizer, or operated ungrounded but impulse protected, the minimum neutral

TABLE 6—MINIMUM INSULATION CLASS AT TRANSFORMER NEUTRAL

(1) Winding Insulation Class at Line End	(2) Grounded Solidly or Through Current Transformer	(3) Grounded Through Regulating Transformer	(4) Grounded Through Ground Fault Neutralizer or Isolated but Impulse Protected
1.2			
2.5			
5.0		Same as Line	End
8.66			
15	8.66	8.66	8.66
25	8.66	8.66	15
34.5	8.66	8.66	25
46	15	15	34.5
69	15	15	46
92	15	25	69
115	15	25	69
138	15	34.5	92
161	15	34.5	92
196	15	46	115
230	15	46	138
287	15	69	161
345	15	69	196

insulation class shall be in accordance with Column 4 of Table 6.

VI. TEMPERATURE AND SHORT-CIRCUIT STANDARDS

17. Temperature Standards

The rating of electrical apparatus is inherently determined by the allowable operating temperatures of insulation, or the temperature rise of the insulation above ambient temperature. For transformers and voltage regulators with Class A insulation, either air or oil cooled, the rating is based on an observable temperature rise (by resistance or thermometer) of 55 C above an ambient temperature at no time in excess of 40 C, and the average during any 24-hour period not exceeding 30 C. Transformers and other induction apparatus are designed to limit the hottest-spot temperatures of the windings to not more than 10 C above their average temperatures under continuous rated conditions. The limits of observable temperature rise for air-cooled transformers with Class B insulation is 80 C by resistance measurement.

18. Short-Circuit Conditions

A proposed revision to American Standard C57.12-1948 (section 12.050) reads in part:

- "1. Transformers shall be capable of withstanding without injury short circuits on any external terminals, with rated line voltages maintained on all terminals intended for connection to sources of power, provided:
 - (a) The magnitude of the symmetrical current in any winding of the transformer, resulting from the external short circuit, does not exceed 25 times the base current of the

winding. The initial current is assumed to be completely displaced from zero.

- (b) The duration of the short circuit is limited to the following time periods. Intermediate values may be determined by interpolation.

Symmetrical Current in Any Winding	Time Period in Seconds
25 times base current	2
20 times base current	3
16.6 times base current	4
14.3, or less, times base current	5

- "2. Where kva is mentioned in paragraph 3 the following is intended:

When the windings have a self-cooled rating, the kva of the self-cooled rating shall be used. When the windings have no self-cooled ratings, the largest kva obtained from the ratings assigned for other means of cooling by the use of the following factors shall be used:

Type of Transformer	Multiplying Factor
Water-cooled (OW)	1.0
Dry-Type Forced-Air-Cooled (AFA)	0.75
Forced-oil-cooled (FOA or FOW)	0.60

- "3. For multi-winding transformers:

The base current of any winding provided with external terminals, or of any delta-connected stabilizing winding without terminals, shall be determined from the rated kva of the winding or from not less than 35 percent of the rated kva of the largest winding of the transformer, whichever is larger.

"In some cases, the short-circuit current, as limited by transformer impedance alone, will exceed 25 times base current. It must be recognized that such cases can occur with transformers manufactured according to these standards and that the transformers built under these standards are not designed to withstand such short-circuit current."

Under short-circuit conditions the calculated copper temperatures for power and distribution transformers shall not exceed 250 C where Class A insulation is used assuming an initial copper temperature of 90 C, or 350 C where Class B insulation is used assuming an initial copper temperature of 125 C.

VII. TRANSFORMER TEMPERATURE-TIME CURVES

19. Constant Load

A "heat run" of a transformer on test is made to determine the temperature rise of the various parts at rated load. If the test were made by applying only rated load, with the transformer at room temperature, thirty hours or more would be required before stationary temperatures were reached. Such a process would be quite inefficient of time, energy, and in the use of testing facilities. Accelerated heat runs are made by closing radiator valves, etc., and applying loads in excess of rated load until the expected temperatures are reached. Radiation restrictions are then removed, the load reduced to normal, and the test continued until stable temperatures are reached.

It is evident that the temperature-time characteristics of a transformer cannot be obtained from the accelerated heat-run data. Information is secured from the heat run, however, which permits the temperatures to be calculated under assumed load conditions. Exact calculations are quite involved, but sufficiently accurate results can be obtained by the use of an approximate method due to S. B. Griscom for estimating the temperatures reached under variable load conditions, changing ambient temperatures, etc. Certain simplifying assumptions can be made that permit a quick estimate of the expected temperatures.

Let L = transformer load in kva.

W = total losses (in kw) at load L .

T_F = final temperature rise at load L in degrees C above the temperature at $t=0$.

M = thermal capacity in kw hours per degree C.

k = radiation constant in kw per degree C.

T = oil temperature rise in degrees C at time t above the temperature at $t=0$.

H = thermal time constant in hours.

t = time in hours.

If the heat radiated is directly proportional to the temperature rise of the transformer above the ambient, the radiation constant can be obtained from the heat run data for W and T_F :

$$k = \frac{W}{T_F} \quad (23)$$

where the temperature at $t=0$ is taken as ambient.

Since the total heat generated is equal to the heat radiated plus the heat stored (heat consumed in raising the temperatures of the various parts)

$$W = kT + M \frac{dT}{dt} \quad (24)$$

This equation can be solved for T , giving

$$T = \frac{W}{k} \left(1 - \epsilon^{-\frac{t}{M/k}} \right) \quad (25)$$

or

$$T = T_F \left(1 - \epsilon^{-\frac{t}{H}} \right) \quad (26)$$

where

$$H = \frac{M}{k} = \text{the transformer time constant in hours.} \quad (27)$$

This derivation may be broadened to show that Eq. (26) is equally correct for the case where the oil temperature rises T and T_F are those above the temperature at $t=0$, whether the value then is the ambient temperature or otherwise.

The foregoing discussion has been based on the assumption that the temperature throughout all parts of the transformer is the same. This, of course, is not the case. When the transformer load is increased, the copper temperature is above that of the surrounding parts, and when the load is decreased, the copper tends to be more nearly the same temperature as the surrounding parts. Also, the top and bottom oil are at different temperatures. Eq. (26) is therefore commonly taken as referring to the top-oil

temperature rise, that is, T and T_F are defined as before but refer to the top-oil specifically. Further, the final top-oil temperature rise T_F is not directly proportional to the losses for all types of transformers as Eq. (23) would indicate, but is more correctly represented by the relation

$$T_F = T_{F(t)} \left(\frac{W}{\text{Total loss at full load}} \right)^m \quad (28)$$

where:

$m=0.8$ for type OA transformers.

$=0.9$ for type OA/FA transformers.

$=1.0$ for type FOA transformers.

$T_{F(t)}$ = final top-oil temperature rise at full load in degrees C.

The use of this relation when substituted in Eq. (23) indicates that for other than the type FOA transformer the radiation constant k and the time constant H are not completely independent of load but vary according to a small fractional power of the total loss. However for convenience in calculations this variation in k and H is normally overlooked and the values obtained from Equations (23) and (27) for the full load condition are taken as constant. The error introduced by the procedure is not large compared to that normally expected in transient thermal calculations.

To determine the temperature rise curve for any load L therefore, the radiation constant k under full load conditions is first determined from the heat run data using Eq. (23). The thermal capacity M is dependent on the thermal capacities of the various parts of the transformer. For convenience it can be assumed that the transformer parts can be separated into three elements: the core and coils, the case and fittings, and the oil. Although the core and coils are of copper, iron, and insulation the specific heats of those elements do not vary widely. Since, also, there is a reasonably constant proportion of these elements in different transformers, a single weighted coefficient of thermal capacity for the coils and core is warranted. The following relation is accordingly suggested:

$$M = \frac{1}{1000} [0.06 (\text{wt. of core and coils}) + 0.04 (\text{wt. of case and fittings}) + 0.17 (\text{wt. of oil})] \quad (29)$$

Here the coefficients of the last two terms are also weighted to make further allowance for the fact that all parts of the case and fittings and the oil are not at a uniform temperature. The values of k and M found as above may be substituted in Eq. (27) to obtain H . The value of T_F for the desired load L is determined next by substitution of heat run data in Eq. (28). The quantity W for the load L may be evaluated by the relation

$$W = \left[\left(\frac{L}{\text{Full load kva}} \right)^2 \times (\text{full load copper loss}) + (\text{no-load loss}) \right] \quad (30)$$

The quantities H and T_F may now be substituted in Eq. (26) from which the top-oil temperature-rise curve may be plotted directly.

For example, a 6000-kva, three-phase, self-cooled, 24 000-5040 volt transformer has the following full load performance data as supplied by the manufacturer:

- Iron loss = 10 920 watts.
- Copper loss = 43 540 watts.
- Total = 54 460 watts.
- Top-oil rise = 40 C (from heat-run test data).
- LV copper rise = 46.3 C.
- HV copper rise = 43.3 C.
- Wt. of core and coils = 25 000 pounds.
- Wt. of case and fittings = 18 000 pounds.
- Wt. of oil = 17 400 pounds.

From this information the time constant H may be evaluated and the expression for T obtained for the load L equal to the rated load.

$$k = \frac{W}{T_F} = \frac{54.46}{40} = 1.36 \text{ kw per degree C.}$$

$$M = \frac{1}{1000} [0.06 \times 25\ 000 + 0.04 \times 18\ 000 + 0.17 \times 17\ 400] = 5.18 \text{ kw hours per degree C.}$$

$$H = \frac{M}{k} = \frac{5.18}{1.36} = 3.81 \text{ hours.}$$

$$T = T_F(1 - e^{-t/H}) = 40(1 - e^{-t/3.81}).$$

The full load top-oil temperature rise curve shown in Fig. 16 was calculated from this relation.

To plot the top-oil temperature-rise curve for half-load conditions for this transformer the same time constant H is used as found above.

From Eq. (28):

$$T_F = 40 \left(\frac{(0.5)^2 \times 43.54 + 10.92}{54.46} \right)^{0.8} = 19.2 \text{ C.}$$

$$T = 19.2 \left(1 - e^{-\frac{t}{3.81}} \right).$$

The curve represented by this equation also appears in Fig. 16.

The rise of the hottest-spot copper temperature above the top-oil temperature is known as the hottest-spot copper gradient and at full load may be estimated from the relation

$$G_{H(t)} = G_{C(t)} + A. \tag{31}$$

where:

$G_{H(t)}$ = hottest spot copper gradient at full load in degrees C.

$G_{C(t)}$ = apparent copper gradient at full load in degrees C.

- A = 10 C for type OA and OW transformers.
- = 10 C for type OA/FA transformers.
- = 5 C for type FOA and FOW transformers with directed flow over coils.

The apparent copper gradient at full load ($G_{C(t)}$) is the difference between the average copper temperature rise and the top-oil temperature rise, both of which are de-

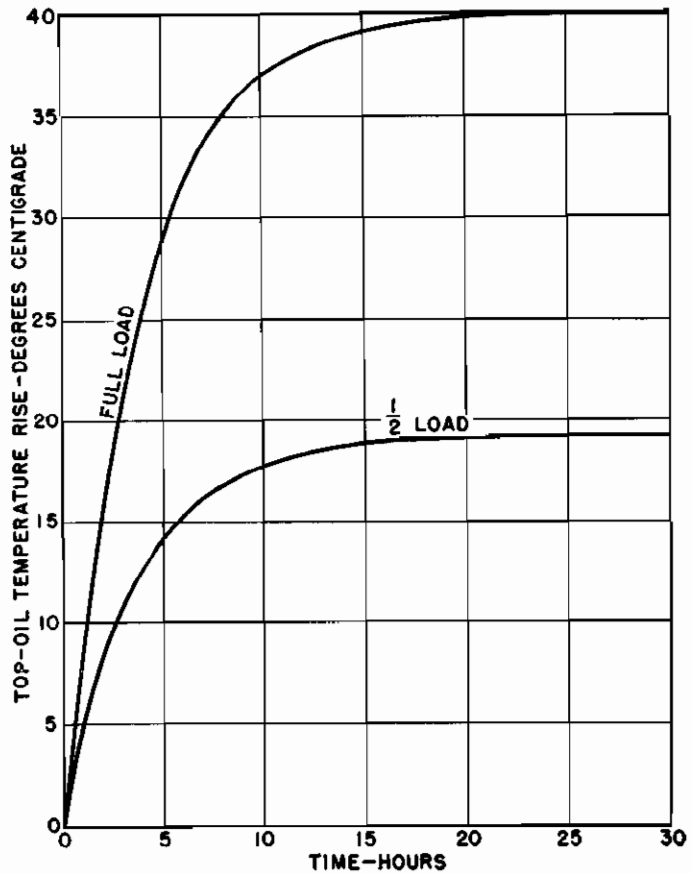

Fig. 16—Top-oil temperature rise versus time, for a typical transformer.

termined during the heat-run. The average copper temperature rise above ambient at full load is required by standards not to exceed 55 C for class A insulation. The use of that value to obtain the apparent copper gradient will generally lead to overly pessimistic results since the actual value of the average copper temperature rise is normally below the limit. Therefore it is advisable to use the value measured on the heat run and obtained from the manufacturer.

For any load L , the hottest-spot copper gradient may be calculated from the relation

$$G_{H(L)} = G_{H(t)} \times \left(\frac{L}{\text{full load kva}} \right)^{1.6} \tag{32}$$

From the performance data of the transformer previously cited:

$$G_{C(t)} = 46.3 - 40 = 6.3 \text{ C for the LV winding.}$$

$$G_{H(t)} = 6.3 + 10 = 16.3 \text{ C.}$$

The hottest-spot copper temperature for full-load is thus 16.3 C above the top-oil temperature. For, say, half-load, Eq. (32) must be used to obtain

$$G_{H(L)} = 16.3 \times (0.5)^{1.6} = 5.4 \text{ C.}$$

It is not feasible in a study of this kind to keep track of short time variations of copper or hottest-spot temperature, and it is suggested if it is desirable to show roughly how this varies, a time constant of 15 minutes be used.

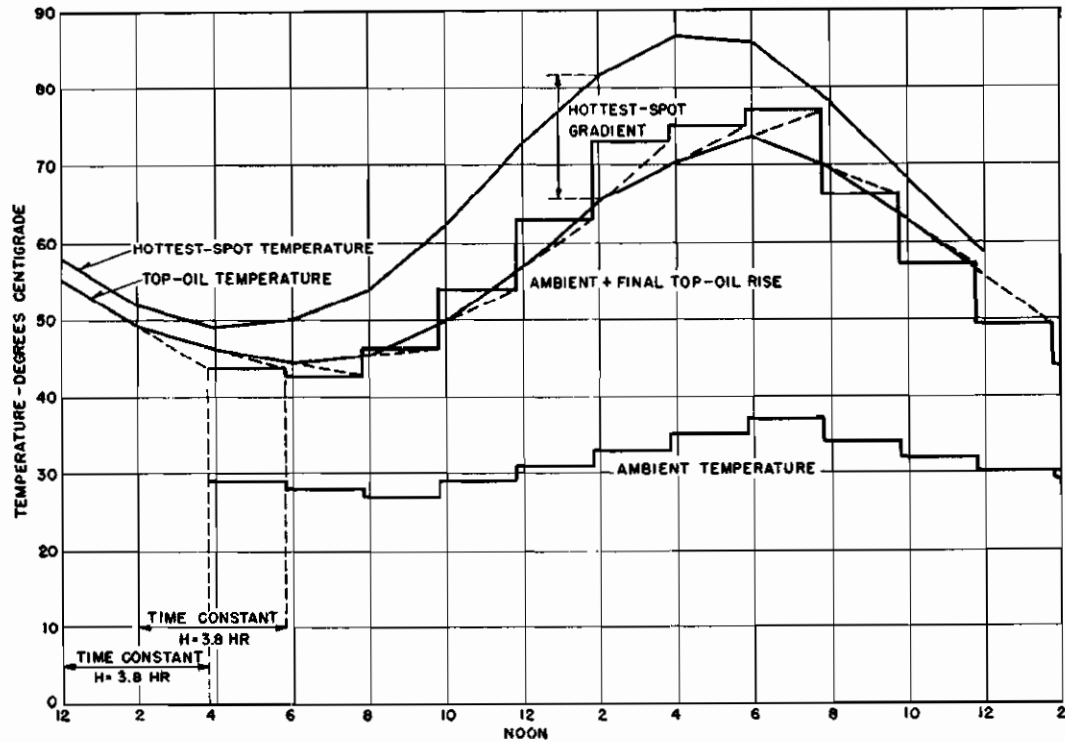

Fig. 17—Step-by-step graphical calculation of temperatures under changing load conditions.

20. Variable Load

A step-by-step analysis using Eqs. (28) to (32) can be made to consider conditions of variable load, changing ambient temperatures, etc. The method of approach is based on the fact that the initial rate of change of temperature is the slope of a line joining the initial and final temperatures, the two temperatures being separated by a time interval equal to the thermal time constant of the transformer. As before T_F is calculated from heat run data and the total loss W for each load condition through the use of Eq. (28). The loss W is obtained from Eq. (30). The final top-oil temperature is then found by adding T_F to the ambient temperature. Since the load is varying, the final temperature cannot be reached for each load condition and the step-by-step analysis must be employed to obtain the top-oil temperature curve. Points on the hottest-spot temperature time curve may then be obtained by adding the hottest-spot copper gradient G_H for each load to the top-oil temperature at the time corresponding to the load for which the gradient was calculated. G_H is obtained in the same manner as previously outlined.

To illustrate the step-by-step method, the oil temperature-time curve for the 6000-kva transformer previously described will be calculated, starting with an oil temperature of 55 C for an assumed load cycle as tabulated in the adjacent column.

Figure 17 illustrates the use of the calculated data in the graphical step-by-step process to plot the curve of top-oil temperature with time and the manner in which the hottest-spot gradients are added to obtain the hottest-spot temperature-time curve. The accuracy can be increased by using shorter time intervals.

Time	Ambient	Load (mva)	Loss Eq. (30)	Final Oil Rise Eq. (28)	Final Oil Temp. ambient plus final rise	Hottest-Spot Gradient Eq. (32)
12	29C	2	15.7	14.7C	43.7C	2.8C
2 AM	29	2	15.7	14.7	43.7	2.8
4	28	2	15.7	14.7	42.7	2.8
6	27	3	21.8	19.2	46.2	5.4
8	29	4	30.2	24.9	53.9	8.5
10	31	5	41.1	31.9	62.9	12.2
12	33	6	54.5	40.0	73.0	16.3
2 PM	35	6	54.5	40.0	75.0	16.3
4	37	6	54.5	40.0	77.0	16.3
6	34	5	41.1	31.9	65.9	12.2
8	32	4	30.2	24.9	56.9	8.5
10	30	3	21.8	19.2	49.2	5.4
12	29	2	15.7	14.7	43.7	2.8

VIII. GUIDES FOR LOADING OIL-IMMERSED POWER TRANSFORMERS

21. General

The rated kva output of a transformer is that load which it can deliver continuously at rated secondary voltage without exceeding a given temperature rise measured under prescribed test conditions. The actual test temperature rise may, in a practical case, be somewhat below the established limit because of design and manufacturing tolerances.

The output which a transformer can deliver in service without undue deterioration of the insulation may be more or less than its rated output, depending upon the following

design characteristics and operating conditions as they exist at a particular time⁶:

- (1) Ambient temperature.
- (2) Top-oil rise over ambient temperature.
- (3) Hottest-spot rise over top-oil temperature (hottest-spot copper gradient).
- (4) Transformer thermal time constant.
- (5) Ratio of load loss to no-load loss.

22. Loading Based on Ambient Temperature

Air-cooled oil-immersed transformers built to meet established standards will operate continuously with normal life expectancy at rated kva and secondary voltage, providing the ambient air temperature averages no more than 30 C throughout a 24-hour period with maximum air temperature never exceeding 40 C. Water-cooled transformers are built to operate continuously at rated output with ambient water temperatures averaging 25 C and never exceeding 30 C.

When the average temperature of the cooling medium is different from the values above, a modification of the transformer loading may be made according to Table 7. In

TABLE 7—PERCENT CHANGE IN KVA LOAD FOR EACH DEGREE CENTIGRADE CHANGE IN AVERAGE AMBIENT TEMPERATURE

Type of Cooling	Air above 30 C avg. or Water above 25 C avg.	Air below 30 C avg. or Water below 25 C avg.
	Self-cooled	-1.5% per deg. C
Water-cooled	-1.5	+1.0
Forced-Air-Cooled	-1.0*	+0.75*
Forced-Oil-Cooled	-1.0*	+0.75*

*Based on forced-cooled rating.

cases where the difference between maximum air temperature and average air temperature exceeds 10 C, a new temperature that is 10 C below the maximum should be used in place of the true average. The allowable difference between maximum and average temperature for water-cooled transformers is 5 C.

23. Loading Based on Measured Oil Temperatures

The temperature of the hottest-spot within a power transformer winding influences to a large degree the deterioration rate of insulation. For oil-immersed transformers the hottest-spot temperature limits have been set at 105 C maximum and 95 C average through a 24 hour period; normal life expectancy is based on these limits. The top-oil temperature, together with a suitable temperature increment called either *hottest-spot copper rise over top-oil temperature* or *hottest-spot copper gradient*, is often used as an indication of hottest-spot temperature. Allowable top-oil temperature for a particular constant load may be determined by subtracting the hottest-spot copper gradient for that load from 95 C. The hottest-spot copper gradient must be known from design information for accurate results, though typical values may be assumed for estimating purposes. If the hottest-spot copper gradient is known for one load condition, it may be estimated for other load conditions by reference to Fig. 18.

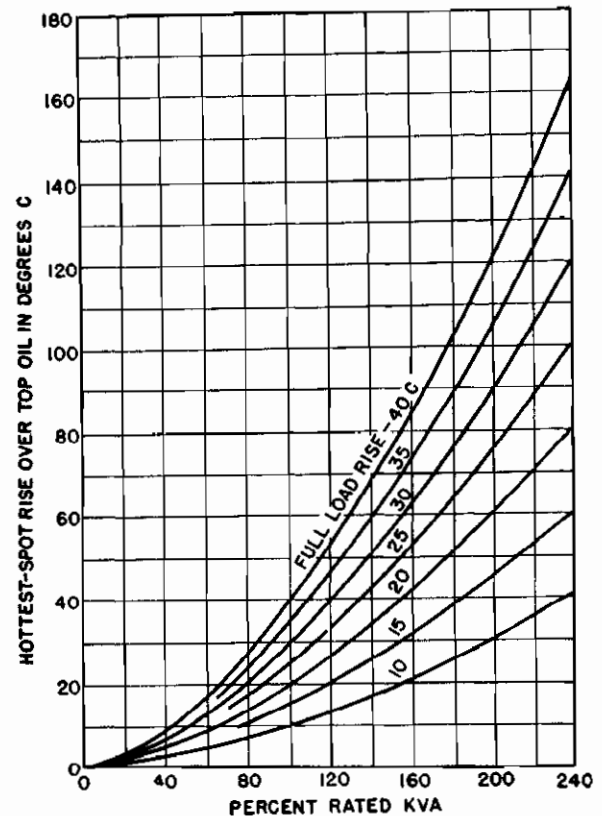

Fig. 18—Hottest-spot copper rise above top-oil temperature as a function of load, for various values of full load copper rise.

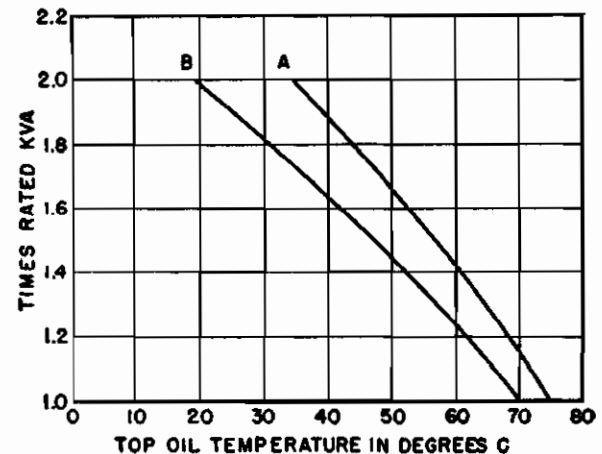

Fig. 19—Loading guide based on top-oil temperature.

- (A) OA, OW, OA/FA types.
- (B) OA/FA/FOA, FOA, FOW types.

A conservative loading guide, based on top-oil temperatures, is given in Fig. 19.

24. Loading Based on Capacity Factor

Transformer capacity factor (operating kva divided by rated kva) averaged throughout a 24-hour period may be well below 100 percent, and when this is true some compensating increase in maximum transformer loading may be made. The percentage increase in maximum loading

TABLE 8—PERMISSIBLE TRANSFORMER LOADING BASED ON AVERAGE PERCENT CAPACITY FACTORS*

Type of Cooling	Percent Increase Above Rated kva For each Percent By Which Capacity Factor Is Below 100	Maximum Percent Increase, Regardless of Capacity Factor
Self-Cooled	0.5	25
Water-cooled	0.5	25
Forced-Air-Cooled	0.4	20
Forced-Oil-Cooled	0.4	20

*Here, percent capacity factor is equal to $\frac{\text{operating kva}}{\text{rated kva}} \times 100$, averaged throughout a 24-hour period.

as a function of capacity factor, based on a normal transformer life expectancy, is given in Table 8.

25. Loading Based on Short-Time Overloads

Short-time loads which occur not more than once during any 24-hour period may be in excess of the transformer rating without causing any predictable reduction in transformer life. The permissible load is a function of the average load previous to the period of above-rated loading, according to Table 9. The load increase based on capacity factor and the increase based on short-time overloads cannot be applied concurrently; it is necessary to chose one method or the other.

Short time loads larger than those shown in Table 9 will cause a decrease in probable transformer life, but the amount of the decrease is difficult to predict in general terms. Some estimate of the sacrifice in transformer life can be obtained from Table 10(a) which is based on the

TABLE 9—PERMISSIBLE DAILY SHORT-TIME TRANSFORMER LOADING BASED ON NORMAL LIFE EXPECTANCY

Period of Increased Loading, Hours	Maximum Load In Per Unit of Transformer Rating ^(a)								
	OA, OW			OA/FA ^(b)			OA/FA/FOA, ^(c) FOA		
	Average ^(d) Initial Load, In Per Unit of Transformer Rating								
	0.90	0.70	0.50	0.90	0.70	0.50	0.90	0.70	0.50
0.5	1.59	1.77	1.89	1.45	1.58	1.68	1.36	1.47	1.50
1	1.40	1.54	1.60	1.31	1.38	1.50	1.24	1.31	1.34
2	1.24	1.33	1.37	1.19	1.23	1.26	1.14	1.18	1.21
4	1.12	1.17	1.19	1.11	1.13	1.15	1.09	1.10	1.10
8	1.06	1.08	1.08	1.06	1.07	1.07	1.05	1.06	1.06

(a) Ambient temperatures of 30C for air and 25C for water are assumed throughout this table.
 (b) Based on FA rating.
 (c) Based on FOA rating.
 (d) Use either average load for two hours previous to overload period, or average load for 24 hours (less the overload period), whichever is greater.

theoretical conditions and limitations described in Table 10(b). These conditions were chosen to give results containing some probable margin, when compared with most conventional transformer designs. For special designs, or for a more detailed check on some particular unit, the hottest-spot copper temperature can be calculated by the method shown in section 19, and the probable sacrifice in transformer life can then be estimated from Table 11.

26. Limiting of Load by Automatic Control

The loading of a transformer can be supervised by control devices to insure that hottest-spot copper temperatures

TABLE 10(a)—PERMISSIBLE SHORT-TIME TRANSFORMER LOADING, BASED ON REDUCED LIFE EXPECTANCY

Type of Cooling	Period of Increased Loading Hours	Following 50 percent or less of rated kva ^(a)				Following 100 percent of rated kva ^(b)			
		Probable Sacrifice In Percent of Normal Life Caused By Each Overload							
		0.10	0.25	0.50	1.00	0.10	0.25	0.50	1.00
Maximum Load In Per Unit Of Transformer Rating									
OA or OW	0.5	2.00	2.00	2.00	2.00	1.75	1.92	2.00	2.00
	1.0	1.76	1.91	2.00	2.00	1.54	1.69	1.81	1.92
	2.0	1.50	1.62	1.72	1.82	1.35	1.48	1.58	1.68
	4.0	1.27	1.38	1.46	1.53	1.20	1.32	1.40	1.48
	8.0	1.13	1.21	1.30	1.37	1.11	1.20	1.28	1.35
24.0	1.05	1.10	1.15	1.23	1.05	1.09	1.15	1.23	
OA/FA ^(c)	0.5	1.97	2.00	2.00	2.00	1.67	1.82	1.94	2.00
	1.0	1.66	1.79	1.90	2.00	1.47	1.60	1.71	1.81
	2.0	1.39	1.51	1.59	1.68	1.29	1.41	1.50	1.58
	4.0	1.21	1.31	1.38	1.45	1.18	1.28	1.35	1.43
	8.0	1.11	1.19	1.26	1.33	1.10	1.18	1.26	1.33
24.0	1.05	1.09	1.15	1.22	1.05	1.09	1.15	1.21	
OA/FA/FOA ^(d) or FOA	0.5	1.78	1.92	2.00	2.00	1.56	1.70	1.80	1.90
	1.0	1.53	1.64	1.73	1.82	1.39	1.50	1.59	1.69
	2.0	1.32	1.42	1.49	1.57	1.26	1.36	1.43	1.51
	4.0	1.18	1.26	1.33	1.40	1.16	1.25	1.32	1.39
	8.0	1.10	1.17	1.24	1.31	1.10	1.18	1.24	1.31
24.0	1.05	1.08	1.14	1.20	1.05	1.09	1.14	1.20	

(a) More basically, following a top-oil rise of 25 C for OA and OA/FA transformers, or a 22 C rise for OA/FA/FOA and FOA units.
 (b) More basically, following a top-oil rise of 45 C for OA and OA/FA transformers, or a 40 C rise for OA/FA/FOA and FOA units.
 (c) Based on the FA kva rating.
 (d) Based on the FOA kva rating.

TABLE 10(b)—CONDITIONS AND TRANSFORMER CHARACTERISTICS ASSUMED IN THE PREPARATION OF TABLE 10(a)

	OA OW	OA/FA	OA/FA/FOA FOA FOW
Hottest-spot rise (C)	65	65	65
Top-oil rise (C)	45	45	40
Time constant at full load (hours)	3.0	2.0	1.5
Ratio of full load copper to iron loss	2.5	3.5	5.0
Ambient temperature = 30 C. Maximum oil temperature = 100 C. ^a Maximum hottest-spot copper temperature = 150 C. Maximum short-time loading = 200 percent. ^b			

(a) Based on provision for oil expansion, and inert gas above the oil.
(b) Short-time loading for one-half hour or more. Terminals or tap-changers might in some cases impose a limit lower than 200 percent.

TABLE 11—PROBABLE SACRIFICE IN TRANSFORMER LIFE CAUSED BY PROLONGED HOTTEST-SPOT COPPER TEMPERATURE

Period of High Temperature, hours	0.10	0.25	0.50	1.00
	Temperature In Degrees Centigrade To Sacrifice Not More Than The Above Percent of Normal Life			
0.5	132	142	150	
1.0	124	134	142	150
2.0	117	126	134	142
4.0	111	119	126	134
8.0	105	112	119	126
24.0	99	104	109	115

are always within a permissible range and duration. This control may be accomplished with a thermal relay responsive to both top-oil temperature and to the direct heating effect of load current. The thermostatic element of this relay is immersed in the hot transformer oil, and it also carries a current proportional to load current: in this way the temperature of the element is geared to the total temperature that the transformer winding attains during operation. The relay can be arranged to close several sets of contacts in succession as the copper temperature climbs with increasing load: the first contacts to close can start fans or pumps for auxiliary cooling, the next contacts can warn of temperatures approaching the maximum safe limit, and the final contacts can trip a circuit breaker to remove load from the transformer.

Loading by copper temperature makes available the short-time overload capacity of a power transformer, so that emergency loads can be carried without interruption of power service, and so that peak loads can be carried without the use of over-size transformers.⁷ The thermal relay can be coordinated with each transformer design to which it is applied, and it can inherently follow unpredictable factors that affect permissible safe loading for a particular installation.

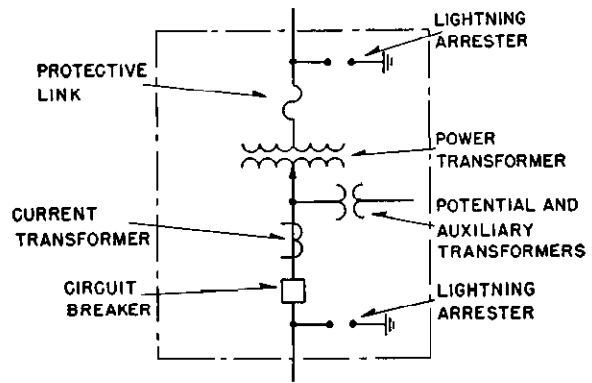

Fig. 20—Single-line diagram of CSP power transformer.

IX. THE COMPLETELY SELF-PROTECTED TRANSFORMER

A power transformer design may include protective devices capable of preventing damage to the unit when it is subjected to electrical conditions that would probably damage conventional transformers. Also, standard switching, metering, and voltage regulating functions may be included within a power transformer assembly. When these protective, switching, and metering features are all combined at the factory within a single unit, as indicated in Fig. 20, it may be designated a CSP power transformer.

Lightning Protection—Coordinated arresters are installed to protect both high- and low-voltage circuits from lightning or other voltage surges.

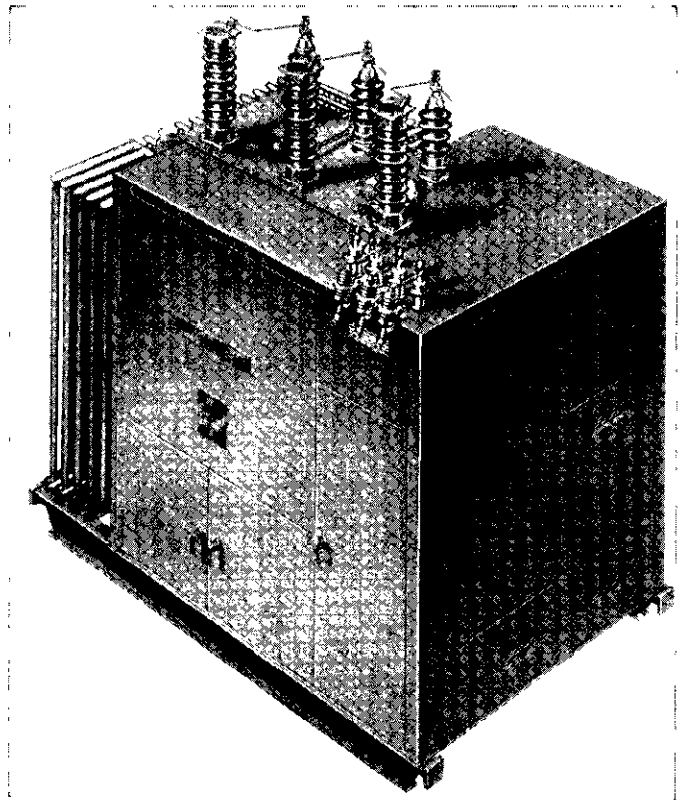

Fig. 21—Fully assembled 3000 kva, 33-4.16 kv CSP power transformer.

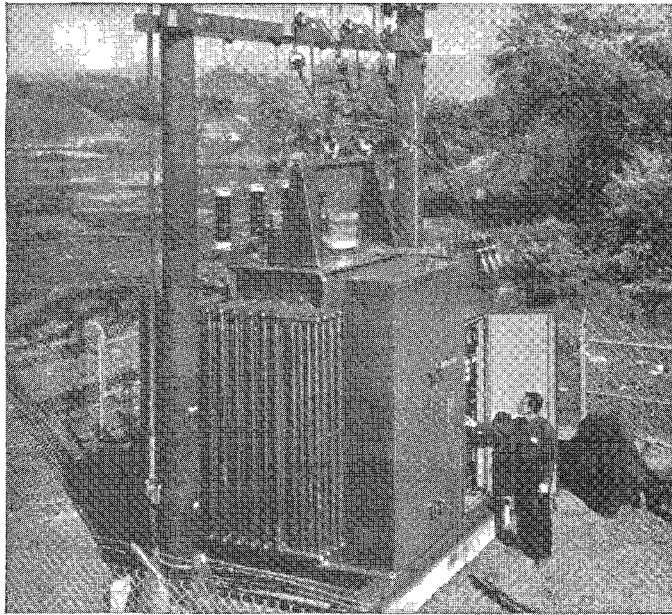

Fig. 22—Installation view of 1500 kva, 13.2-4.33 kv CSP power transformer.

Internal Fault Protection—Fusible protective links of high interrupting capacity are connected between the high-voltage bushings and the winding, so that the supply circuit can be cleared from internal transformer faults.

Overload Protection—A thermal relay, responsive to copper temperature (see section 26), operates to trip the secondary circuit breaker before damaging temperatures develop in the winding.

Relaying—Overcurrent relays normally are provided in the low-voltage circuit to protect for secondary faults.

Circuit Breaker—Load switching is accomplished by a circuit breaker in the low-voltage circuit of the transformer.

Voltage Regulation—Standard no-load taps are pro-

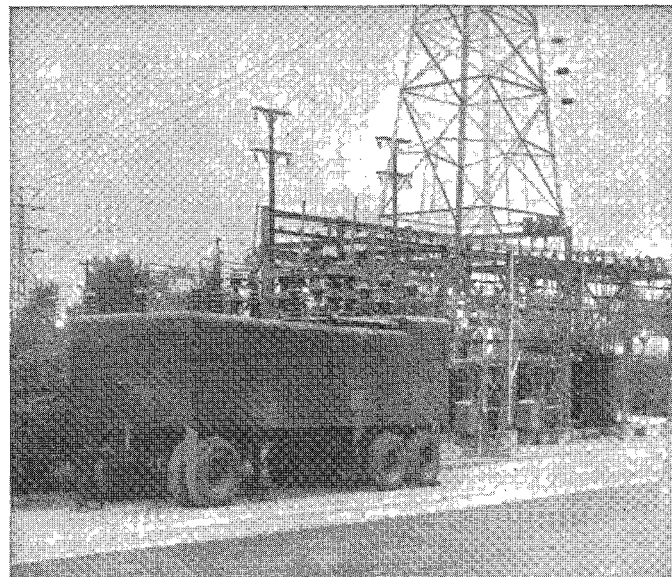

Fig. 23—Portable substation rated 2000 kva, 72 000/24 000—2.5/4.33/5.0/7.5 kv, shown in operation at a substation site.

vided in the high-voltage winding. Tap-changing-under-load equipment for the secondary circuit may be built into the transformer housing.

Metering—Watt-hour meters and ammeters are usually supplied for circuit metering.

CSP transformers are available in kva ratings up to 3000, primary voltages up to 69 kv, and secondary voltages up to 15 kv. The units may be used to supply distribution circuits from high-voltage lines in either industrial or electric utility applications; if one unit is used individually on a radial circuit, a by-passing switch can be supplied across the low-voltage circuit breaker to permit withdrawal and maintenance of the breaker without a service interruption.

X. AUTOTRANSFORMERS

27. Two-Winding Autotransformer Theory

The single-phase two-winding autotransformer contains a primary winding and a secondary winding on a common core, just as a conventional two-winding transformer does. However, in the autotransformer the two windings are interconnected so that the kva to be transformed by actual magnetic coupling is only a portion of the total kva transmitted through the circuit to which the transformer is connected. Autotransformers are normally rated in terms of circuit kva, without reference to the internal winding kva.

The autotransformer circuit shown in Fig. 24 contains

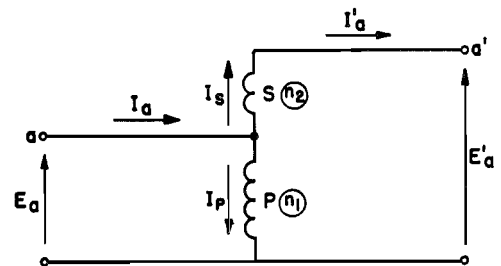

Fig. 24—Circuit for a two-winding autotransformer.

a primary winding P which is common to both low- and high-voltage circuits, and a secondary winding S which is connected directly in series with the high-voltage circuit. Under no-load conditions, high-side circuit voltage E'_a will be the sum of the primary and secondary winding voltages; low-side circuit voltage E_a will be equal to the primary winding voltage. The relation between primary and secondary winding voltages will depend upon the turns ratio

$\frac{n_2}{n_1}$ between these windings.

$$\frac{E'_a}{E_a} = \frac{E_a + \frac{n_2}{n_1} E_a}{E_a} = 1 + \frac{n_2}{n_1} = N. \quad (33)$$

$$\frac{n_2}{n_1} = N - 1. \quad (34)$$

Here N is the overall voltage ratio between high- and low-voltage circuits.

When the transformer is carrying load current, the

primary ampere-turns should essentially balance the secondary ampere-turns (noting that $I'_a = I_s$):

$$n_1 I_P = n_2 I_S = n_2 I'_a \quad (35)$$

$$I'_a = \frac{n_1}{n_2} I_P \quad (36)$$

$$I_a = I_S + I_P = I'_a + \frac{n_2}{n_1} I'_a = N I'_a = N \frac{n_1}{n_2} I_P = \frac{N}{N-1} I_P \quad (37)$$

The total circuit kva is given by $E_a \times I_a$ or $E'_a \times I'_a$ (expressing voltages in kv), but the winding kva is given by $E_a \times I_P$ or $\left(\frac{n_2}{n_1}\right) E_a \times I_S$. The ratio between winding kva (U_P or U_S) and circuit kva (U_C) is, referring to equation (37)

$$\frac{U_P}{U_C} = \frac{E_a \times I_P}{E_a \times I_a} = \frac{I_P}{\left(\frac{N}{N-1}\right) I_P} = \frac{N-1}{N} \quad (38)$$

For example, an autotransformer rated 1000 kva, with a circuit voltage ratio of 22 kv to 33 kv $\left(N = \frac{33}{22} = 1.5\right)$ has an equivalent two-winding kva of

$$U_P = U_S = \frac{N-1}{N} U_C = \frac{1.5-1.0}{1.5} \times 1000 = 333 \text{ kva}$$

The reduced rating of transformer parts required in an autotransformer make it physically smaller, less costly, and of higher efficiency than a conventional two-winding unit for the same circuit kva rating. In the example just cited, the autotransformer would theoretically be only as large as a 333-kva conventional transformer, and this reduced kva would in practice furnish a fairly accurate basis for estimating the cost of the 1000-kva autotransformer. Total losses in the autotransformer would be comparable to those in a 333-kva conventional transformer, so that efficiency based on circuit transmitted power would be quite high.

An autotransformer will introduce series impedance, as well as current and voltage transformation, in the circuit where it is connected. The series impedance may be evaluated by referring to Fig. 25(a); here the low-voltage circuit terminals are short-circuited, so that the impedance measured at the high-voltage terminals will be equal to the series impedance attributable to the autotransformer. Note that the circuit in Fig. 25(a) is exactly the same as the circuit that would be used to measure the leakage impedance if Z_{SP} were defined as the ohmic impedance measured across the secondary winding with the primary winding short-circuited. A circuit providing correct circuit voltage and current ratios, and also correct through impedance, is shown in Fig. 25(b). Two conversions may now be made, the first to move the series impedance to the low-voltage side, and the second to express impedance in terms of Z_{PS} .

$$Z_a = \frac{1}{N^2} Z'_a = \frac{1}{N^2} Z_{SP} \quad (39)$$

$$Z_{SP} = \left(\frac{n_2}{n_1}\right)^2 Z_{PS} = (N-1)^2 Z_{PS} \quad (40)$$

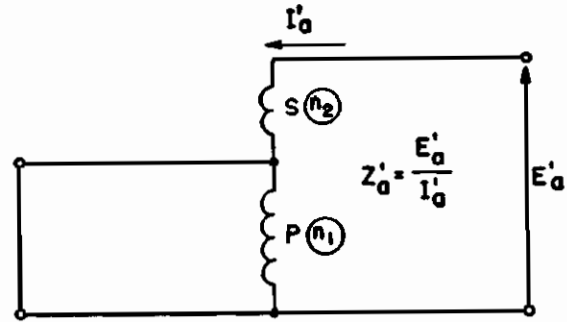

(a) DETERMINATION OF IMPEDANCE TEST

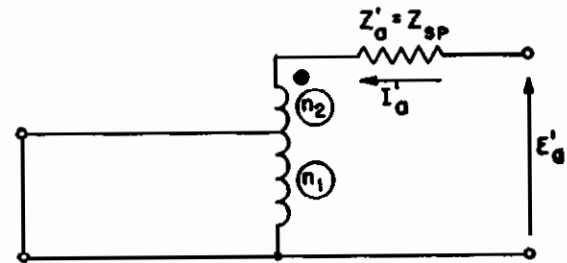

(b) EQUIVALENT OF TEST CIRCUIT

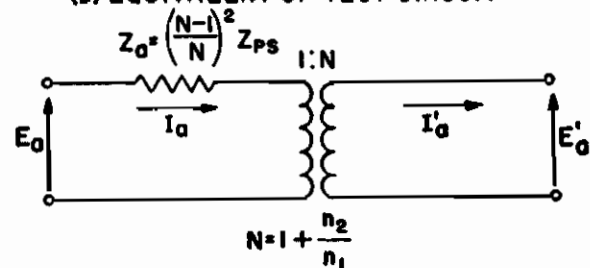

(c) CONVENTIONAL EQUIVALENT CIRCUIT

Fig. 25—Equivalent circuits for a two-winding autotransformer.

From this, the conventional form of equivalent circuit is shown in Fig. 25(c), where

$$Z_a = \left(\frac{N-1}{N}\right)^2 \times Z_{PS} \quad (41)$$

Sequence equivalent circuits for the three-phase two-winding autotransformer are presented in the Appendix.

The circuit impedance of an autotransformer is smaller than that of a conventional two-winding unit of the same rating, as is evident from Eq. (41). This low series impedance, though advantageous in its effect on transformer regulation, may allow excessive short-circuit currents during system fault conditions. Often the through impedance will be less than four percent based on the autotransformer nameplate kva rating, which means that three-phase short circuit current could exceed the maximum of twenty-five times normal rated current for two seconds as permitted by standards. For this reason autotransformers, like voltage regulators, cannot always protect themselves against excessive fault current; reactors or other connected circuit elements may have to be relied on for this protection.

28. The Three-Winding Autotransformer

Three-phase autotransformers for power service are usually star-star connected with the neutral grounded, and in most of these cases it is desirable to have a third winding on the core delta-connected so as to carry the third harmonic component of exciting current. This winding could be very small in capacity if it were required to carry only harmonic currents, but its size is increased by the requirement that it carry high currents during system ground faults. A widely used rule sets the delta-winding rating at 35 percent of the autotransformer equivalent two-winding kva rating (not circuit kva rating).

Since it is necessary in most cases to have a delta-connected tertiary winding, it is often advantageous to design this winding so that load can be taken from it. This results in a three-winding autotransformer with terminals to accommodate three external circuits. The equivalent circuit for this type of transformer is given in section 59 of this chapter.

29. Autotransformer Taps

It is frequently necessary to place taps in the windings of an autotransformer to regulate either or both circuit voltages. It is not advisable to place taps adjacent to the line connections for voltages above 22 000 volts, because extra insulation is necessary on turns adjacent to the line terminals. If taps were placed at the ends of the winding, additional padding would be required throughout the tapped section. Furthermore, taps placed adjacent to the line, where the most severe voltage stresses occur, constitute a weakness that can be avoided by placing the taps in the middle of the winding as shown in Fig. 26. Taps

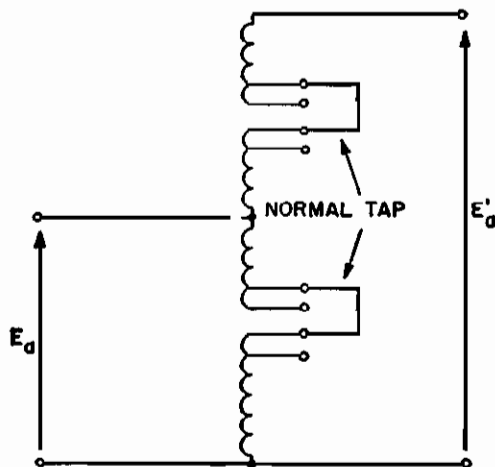

Fig. 26—Autotransformer taps.

may be placed in either the primary (common) winding, or in the secondary (series) winding, or in both windings; however, some tap combinations are more desirable than others, if the transformer materials are to be used most effectively.

The low-side and high-side circuit voltages may be related, under no-load conditions, by an equation which takes account of both primary and secondary taps:

$$E'_a = E_a + \frac{n_2 + t_2 n_2}{n_1 + t_1 n_1} E_a = \frac{n_1(1+t_1) + n_2(1+t_2)}{n_1(1+t_1)} E_a \quad (42)$$

n_1 = turns on primary winding, not considering taps.

n_2 = turns on secondary winding, not considering taps.

t_1 = fractional part of n_1 included in primary winding tap (+ $t_1 n_1$ indicates additional turns)

t_2 = fractional part of n_2 included in secondary winding tap. (+ $t_2 n_2$ indicates additional turns).

If E_a is assumed constant at 1.0 per unit based on normal rated low-side circuit voltage, three cases are possible:

(1) Taps in secondary winding only:

$$E'_a = 1 + \frac{n_2}{n_1} + t_2 \frac{n_2}{n_1} \quad (43)$$

In this case the transformer volts per turn remain normal. The percent change in E'_a is:

$$\Delta E'_a = t_2 \frac{n_2}{n_1 + n_2} 100. \quad (44)$$

(2) Taps in primary winding only:

$$E'_a = 1 + \frac{n_2}{n_1} - \frac{t_1 n_2}{n_1 + n_1 t_1} \quad (45)$$

The transformer volts per turn are $\left(\frac{1}{1+t_1}\right)$ times their normal value. The percent change in E'_a is:

$$\Delta E'_a = -\frac{t_1}{1+t_1} \times \frac{n_2}{n_1 + n_2} 100. \quad (46)$$

(3) Taps in both primary and secondary windings:

$$E'_a = 1 + \frac{n_2}{n_1} + \frac{t_2 - t_1}{1+t_1} \times \frac{n_2}{n_1} \quad (47)$$

As in case (2), the transformer volts per turn are $\left(\frac{1}{1+t_1}\right)$ times their normal value. The percent change in E'_a is:

$$\Delta E'_a = \frac{t_2 - t_1}{1+t_1} \times \frac{n_2}{n_1 + n_2} 100. \quad (48)$$

If E'_a is assumed constant at 1.0 per unit based on normal rated high-side circuit voltage, and E_a is allowed to vary, three more cases are possible:

(4) Taps in secondary winding only:

$$E_a = \frac{n_1}{n_1 + n_2} - \frac{n_1}{n_1 + n_2} \times \frac{n_2 t_2}{n_1 + n_2(1+t_2)} \quad (49)$$

The transformer volts per turn are $\left(\frac{n_1 + n_2}{n_1 + n_2(1+t_2)}\right)$ times their normal value.

The percent change in E_a will be:

$$\Delta E_a = -t_2 \frac{n_2}{n_1 + n_2(1+t_2)} 100. \quad (50)$$

(5) Taps in primary winding only:

$$E_a = \frac{n_1}{n_1 + n_2} + \frac{n_1}{n_1 + n_2} \times \frac{n_2 t_1}{n_1(1+t_1) + n_2} \quad (51)$$

Transformer volts per turn are $\left(\frac{n_1+n_2}{n_1(1+t_1)+n_2}\right)$ times their normal value.

The percent change in E'_a is:

$$\Delta E_a = t_1 \frac{n_2}{n_1(1+t_1)+n_2} 100. \quad (52)$$

(6) Taps in both primary and secondary:

$$E_a = \frac{n_1}{n_1+n_2} + \frac{n_1}{n_1+n_2} \times \frac{n_2(t_1-t_2)}{n_1(1+t_1)+n_2(1+t_2)}. \quad (53)$$

Transformer volts per turn are $\left(\frac{n_1+n_2}{n_1(1+t_1)+n_2(1+t_2)}\right)$ times their normal value. The percent change in E'_a is:

$$\Delta E_a = \frac{n_2(t_1-t_2)}{n_1(1+t_1)+n_2(1+t_2)} 100. \quad (54)$$

If the transformer were designed for constant volts per turn $\left(t_2 = -t_1 \frac{n_1}{n_2}\right)$, then the percent change in E_a would be:

$$\Delta E_a = t_1 \times 100. \quad (55)$$

It is often advisable to specify a tap combination which will allow the autotransformer to operate at practically constant volts-per-turn, regardless of tap position. As indicated in some of the cases above, a tap change in only one winding may be less effective than would normally be anticipated, because of the nullifying effect of the accompanying change in volts-per-turn. Also, a significant increase in volts-per-turn at some tap setting would be reflected in a magnetic core of larger size than otherwise necessary.

30. Autotransformer Operating Characteristics

An autotransformer inherently provides a metallic connection between its low- and high-voltage circuits; this is unlike the conventional two-winding transformer which isolates the two circuits. Unless the potential to ground of each autotransformer circuit is fixed by some means, the low-voltage circuit will be subject to overvoltages originating in the high-voltage circuit. These undesirable effects can be minimized by connecting the neutral of the autotransformer solidly to ground. If the neutral of an autotransformer is always to be grounded in service, an induced potential shop test is more appropriate than an applied potential test, because it represents more closely the field operating conditions; building a grounded autotransformer to withstand a full-voltage applied potential test would not be economical because of the excess insulation near the neutral.

To summarize the preceding discussion, the autotransformer has advantages of lower cost, higher efficiency, and better regulation as compared with the two-winding transformer; it has disadvantages including low reactance which may make it subject to excessive short-circuit currents, the arrangement of taps is more complicated, the delta tertiary may have to carry fault currents exceeding its standard rating, the low- and high-voltage circuits cannot be isolated, and the two circuits must operate with no angular phase displacement unless a zig-zag connection is introduced. The advantages of lower cost and improved effi-

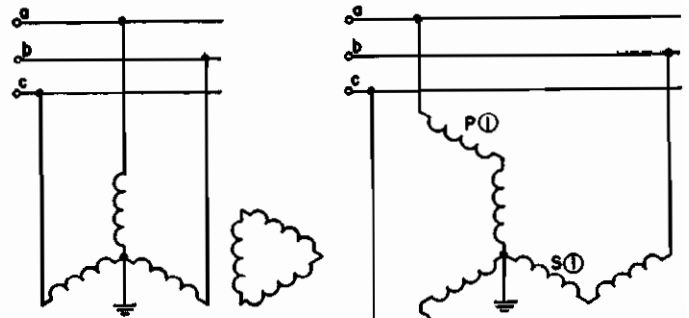

(a) STAR-DELTA GROUNDING-TRANSFORMER

(b) INTERCONNECTED-STAR GROUNDING TRANSFORMER WINDINGS DRAWN PARALLEL ARE ON THE SAME CORE

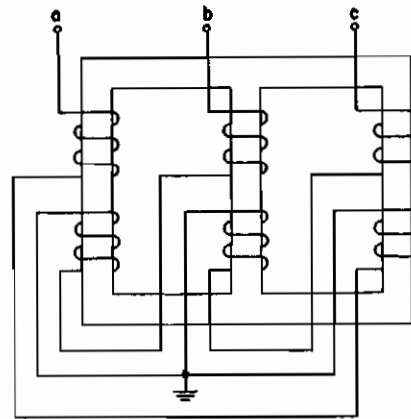

(c) SCHEMATIC WINDING ARRANGEMENT OF AN INTERCONNECTED-STAR GROUNDING TRANSFORMER OF THE THREE-PHASE CORE-FORM CONSTRUCTION

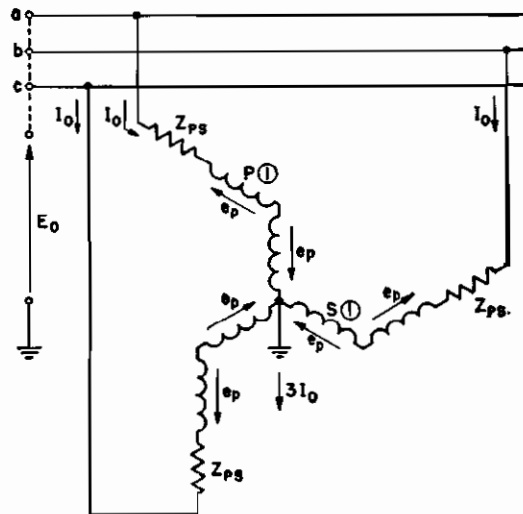

(d) EQUIVALENT CIRCUIT OF AN INTERCONNECTED-STAR GROUNDING TRANSFORMER

Fig. 27—Star-delta and zig-zag grounding transformers.

ciency become less apparent as the transformation ratio increases, so that autotransformers for power purposes are usually used for low transformation ratios, rarely exceeding 2 to 1.

XI. GROUNDING TRANSFORMERS

A grounding transformer is a transformer intended solely for establishing a neutral ground connection on a three-phase system. The transformer is usually of the star-delta or interconnected-star (zig-zag) arrangement as shown in Fig. 27.

The kva rating of a three-phase grounding transformer, or of a grounding bank, is the product of normal *line-to-neutral* voltage (kv) and the *neutral* or *ground* amperes that the transformer is designed to carry under fault conditions for a specified time. A one-minute time rating is often used for grounding transformers, though other ratings such as those suggested in AIEE Standard for "Neutral Grounding Devices" (No. 32, May 1947) can be specified depending upon the probable duty to be imposed on the unit in service.

Rated voltage of a grounding transformer is the line-to-line voltage for which the unit is designed.

When operated at rated three-phase balanced voltage, only exciting current circulates in the windings of a grounding transformer. Current of appreciable magnitude begins to flow in the grounding circuit only when a fault involving ground develops on the connected system.

Grounding transformers, particularly the zig-zag type, normally are designed so that rated neutral current flows when a solid single-line-to-ground fault is applied at the transformer terminals, assuming supply voltage to be fully maintained. This is equivalent to 100-percent zero-sequence voltage impressed at the transformer terminals resulting in the circulation of rated neutral current. Transformers so designed are said to have 100-percent impedance based on rated kva and rated voltage.

Sometimes a resistor or other impedance is connected in the transformer neutral, and in these cases it may be desirable to specify that the grounding transformer shall have less than the conventional 100 percent impedance. Equivalent circuits for star-delta and zig-zag grounding transformers with external neutral impedance are included in the Appendix.

Because a grounding transformer is a short-time device, its size and cost are less than for a continuous duty transformer of equal kva rating. The reduced size can be established in terms of an "equivalent two-winding 55 C kva" U_x by applying a reduction factor K to the short-time rated kva of the grounding transformer, and this reduced kva can be used for a price estimate.

$$U_x = U_G \times K_3 \text{ for a three-phase grounding unit. (56)}$$

$$U_x = 3U_G \times K_1 \text{ for a bank of single-phase grounding units (57)}$$

where

U_x = equivalent two-winding 55 C kva, three-phase.

U_G = (line-to-neutral kv) \times (rated neutral amperes).

Values for K are listed in Table 12 for various types and

Table 12—"K" FACTORS FOR DETERMINING EQUIVALENT TWO-WINDING 55 C KVA OF GROUNDING TRANSFORMERS*

Time Rating	Star-Delta Connection	Zig-Zag Connection				
		2.4 to 13.8 kv	23 to 34.5 kv	46 kv	69 kv	92 kv
K ₃ , For A Three Phase Unit						
10 seconds	0.064	0.076	0.080	0.085	0.092
1 minute	0.170	0.104	0.110	0.113	0.118	0.122
2 minutes	0.240	0.139	0.153	0.160	0.167	0.174
3 minutes	0.295	0.170	0.187	0.196	0.204	0.212
4 minutes	0.340	0.196	0.216	0.225	0.235	0.245
5 minutes	0.380	0.220	0.242	0.253	0.264	0.275
K ₁ , For A Single Phase Unit (One of three in a bank)						
1 minute	0.057	0.033	0.037	0.040	0.043	0.046
2 minutes	0.080	0.046	0.051	0.055	0.060	0.064
3 minutes	0.098	0.057	0.064	0.068	0.074	0.080
4 minutes	0.113	0.065	0.073	0.078	0.084	0.091
5 minutes	0.127	0.073	0.082	0.088	0.095	0.102

*These values are calculated on the basis that the initial average winding temperature is not over 75C, that the heat from load losses is all stored in the transformer, and that the final temperature will not exceed values permitted by standards. The values are applicable only for grounding transformers designed to have 100 percent impedance.

classes of grounding transformers; the table includes values for both three-phase and single-phase units, though the single-phase type is uncommon.

Conventional power transformers may be connected to serve solely as grounding transformers, but the current and time ratings for grounding service are open to question depending upon the form and details of construction. When these modified ratings are desired, they should be obtained from the transformer manufacturer.

Star-Delta Impedances—The impedance to zero-sequence currents in each phase of a solidly-grounded star-delta grounding bank made up of single-phase units is equal to Z_{PS} , the ohmic leakage impedance between one primary (star) winding and the corresponding secondary (delta) winding:

$$Z_0 = Z_{PS} \tag{58}$$

Percent zero-sequence impedance is normally expressed in terms of short-time kva and line-to-line voltage:

$$Z_0\% = \frac{Z_{PS} \times U_G}{10 \times kv^2} \tag{59}$$

In a three-phase star-delta grounding transformer Z_0 may be smaller than Z_{PS} by an amount depending on the form of core construction: a typical ratio of Z_0 to Z_{PS} is 0.85, though variation from this value for different designs is likely.

Zig-zag Impedances—The impedance to zero-sequence currents in each phase of a solidly grounded zig-zag bank can be derived on a theoretical basis by reference to Fig. 27(d).

$$E_0 = I_0 \times Z_{PS} - e_p + e_p \tag{60}$$

$$\frac{E_0}{I_0} = Z_0 = Z_{PS} \tag{61}$$

Percent zero-sequence impedance for the zig-zag connec-

tion is normally expressed in terms of short-time kva and line-to-line voltage:

$$Z_0\% = \frac{Z_{Ps} \times U_G}{10 \times kV^2} \quad (62)$$

XII. TAP CHANGING UNDER LOAD

The modern load tap changer had its beginning in 1925. Since that time the development of more complicated transmission networks has made tap changing under load more and more essential to control the in-phase voltage of power transformers, and in other cases to control the phase angle relation. Tap-changing-under-load equipment is applied to power transformers to maintain a constant secondary voltage with a variable primary voltage; to control the secondary voltage with a fixed primary voltage; to control the flow of reactive kva between two generating systems, or adjust the reactive flow between branches of loop circuits; and to control the division of power between branches of loop circuits by shifting the phase-angle position of transformer output voltages.

Various types of tap-changing equipment and circuits are used depending upon the voltage and kva and also upon whether voltage or phase angle control is required. Under-load-tap-changers are built for 8, 16, and 32 steps, with the trend in recent years being toward the larger number of steps so as to give a finer degree of regulation. The usual range of regulation is plus 10 percent and minus 10 percent of the rated line voltage, with plus and minus 7½ percent and plus and minus 5 percent being second and third, respectively, in popularity. The 32 step, plus and minus 10 percent, tap-changing-under-load equipment has such wide acceptance as to be considered standard for many types of transformers.

31. The UT Mechanism

Figure 28 illustrates schematically the operation of the type UT mechanism for changing taps under load. Taps from the transformer winding connect to selector switches 1 through 9. The selector switches are connected to load transfer switches R, S, and T. The connections for the tap changer positions are shown on the sequence chart of Fig. 28. The sequence of switching is so coordinated by the tap changing mechanism that the transfer switches perform all the switching operations, opening before and closing after the selector switches. All arcing is thus restricted to switches R, S, and T, while switches 1 to 9 merely select the transformer tap to which the load is to be transferred.

When the tap changer is on odd-numbered positions, the preventive auto-transformer is short-circuited. On all even-numbered positions, the preventive auto-transformer bridges two transformer taps. In this position, the relatively high reactance of the preventive auto-transformer to circulating currents between adjacent taps prevents damage to the transformer winding, while its relatively low impedance to the load current permits operation on this position to obtain voltages midway between the transformer taps.

32. The UNR Mechanism

Fig. 29 shows schematically the diagram of connections and sequence of operations of the type UNR tap changer. The operation of the selector and transfer switches is exactly as described for the type UT tap changer. But the type UNR tap changer also has a reversing switch which reverses the connections to the tapped section of the winding so that the same range and number of positions

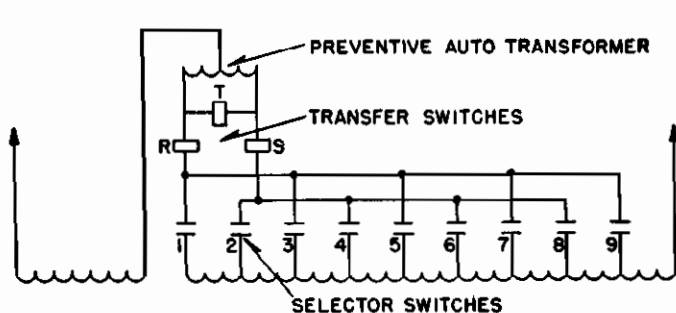

SEQUENCE OF OPERATION

POSITION	1	2	3	4	5	6	7	8	9	10	11	12	13	14	15	16	17
SWITCH-1	0	0															
" -2	0	0	0														
" -3			0	0	0												
" -4				0	0	0											
" -5						0	0	0									
" -6								0	0	0							
" -7										0	0	0					
" -8												0	0	0			
" -9														0	0		
" -R	0	0		0	0	0		0	0	0		0	0	0		0	0
" -S	0	0	0		0	0		0	0	0		0	0	0		0	0
" -T	0		0		0		0		0		0		0		0		0

O = SWITCH CLOSED

Fig. 28—Seventeen position, single-phase, Type UT tap changer.

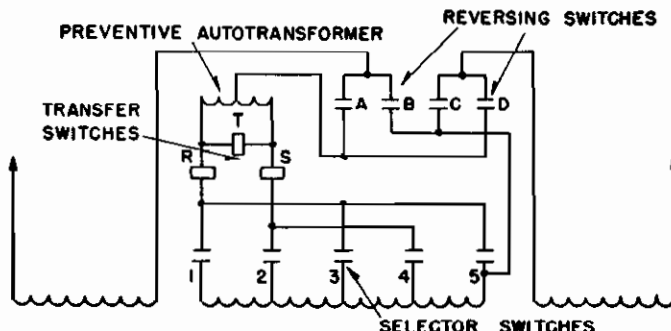

SEQUENCE OF OPERATION

POSITION	1	2	3	4	5	6	7	8	9	10	11	12	13	14	15	16	17
SWITCH-1	0	0															
" -2	0	0	0												0	0	0
" -3			0	0	0							0	0	0			
" -4				0	0	0		0	0	0							
" -5						0	0	0									
" -A									0	0	0	0	0	0	0	0	0
" -B	0	0	0	0	0	0	0	0									
" -C										0	0	0	0	0	0	0	0
" -D	0	0	0	0	0	0	0	0									
" -R	0	0		0	0	0		0	0	0		0	0	0		0	0
" -S	0	0	0		0	0		0	0	0		0	0	0		0	0
" -T	0		0		0		0		0		0		0		0		0

O = SWITCH CLOSED

Fig. 29—Seventeen position, single phase, Type UNR tap changer.

can be obtained with one-half the number of tap sections, or twice the range can be obtained with the same number of taps. The reversing switch is a close-before-open switch which operates at the time there is no voltage across its contacts.

33. The URS Mechanism

The type URS load tap changer is applied to small power transformers and large distribution transformers. The transfer switches are eliminated, and each selector switch serves as a transfer switch for the tap to which it is connected. The schematic circuit diagram and operations sequence chart is shown in Fig. 30.

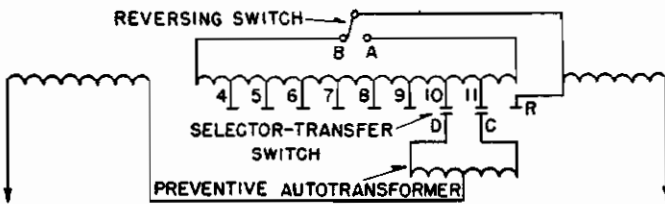

SEQUENCE OF OPERATION																																						
POSITION	1	2	3	4	5	6	7	8	9	10	11	12	13	14	15	16	17	18	19	20	21	22	23	24	25	26	27	28	29	30	31	32	33					
SW D-11	0																																					
" C-11	0	0																																				
" D-10		0	0																																			
" C-10			0	0																																		
" D-9				0	0																																	
" C-9					0	0																																
" D-8						0	0																															
" C-8							0	0																														
" D-7								0	0																													
" C-7									0	0																												
" D-6										0	0																											
" C-6											0	0																										
" D-5												0	0																									
" C-5													0	0																								
" D-4														0	0																							
" C-4															0	0																						
" D-R																0	0																					
" C-R																	0	0																				
" A																		0	0	0	0	0	0	0	0	0	0	0	0	0	0	0	0	0	0	0	0	
" B																			0	0	0	0	0	0	0	0	0	0	0	0	0	0	0	0	0	0	0	

O = SWITCH CLOSED

Fig. 30—Thirty-three position, single-phase, Type URS tap changer.

Physically, the stationary selector switch contacts are arranged in circles, one for each phase. The moving selector switch contacts, as they rotate about a center shaft, both select the taps and make contact with them. The reversing switch operates when the selector switches are on position 17, at which time there is no current through the reversing switches and therefore no arcing on them.

The URS tap changer, like the other load tap changers, can be equipped for hand operation, remote manual operation, or for full automatic operation under the control of relays.

XIII. REGULATING TRANSFORMERS FOR VOLTAGE AND PHASE ANGLE CONTROL

Consider two systems A and B in Fig. 31 connected by a single transmission circuit. A and B may both be generating units, or one of them may be a generating unit and the other a load. Should A generate 10 000 kilowatts in excess of its own load, there can be but one result, the 10 000

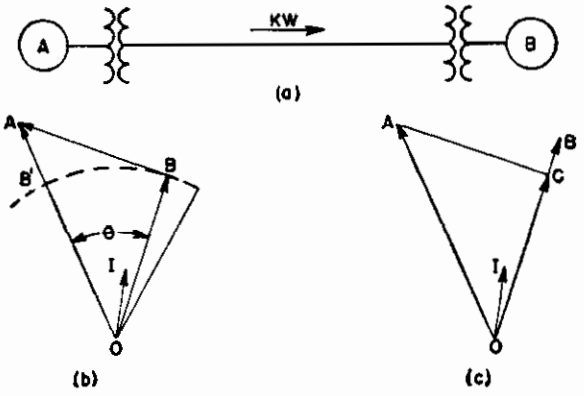

Fig. 31—Power interchange between systems:

- (a) Two systems with tie.
- (b) Vector diagram of voltages during interchange of power.
- (c) Introduction of an in phase voltage, BC, to correct for excessive voltage drop.

kilowatts must go over the tie line to B. An increase in generator output by A must be accompanied by a corresponding decrease in output (increase in input) by B if there is to be no change in system frequency. The transmission of power from A to B results in a difference in magnitude between terminal voltages and also a shift in phase angle, as illustrated in Fig. 31 (b). AO is the terminal voltage at A, BO is the terminal voltage at B. AB is the vectorial voltage drop from A to B, created by the flow of load current I, and θ is the phase-angle difference between terminal voltages. In actual practice the phase angle is not always apparent, but the drop in voltage, AB', is often objectionable. An attempt to maintain satisfactory terminal voltages at A and B will often result in undesirable circulation of reactive kva between the systems. The flow of power from A to B, or vice versa, is determined by the governor settings. The flow of reactive power over the interconnecting line is determined by the terminal voltages held by the machine excitations at A and B. Excessive voltage drop between the systems can be readily corrected by transformer taps of a fixed nature or by tap-changing equipment, introduc-

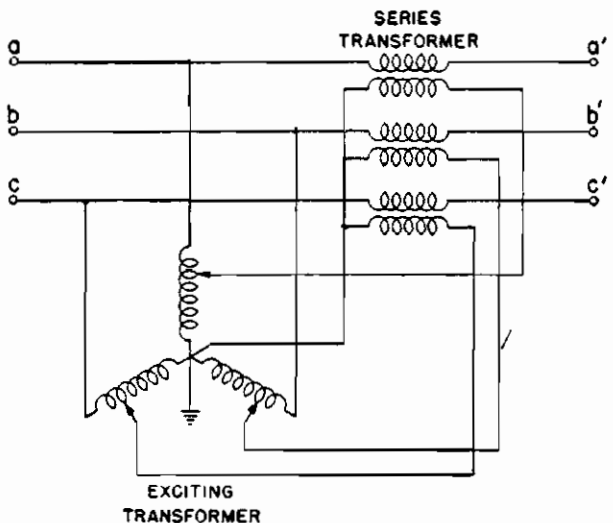

Fig. 32—Regulating transformer for voltage control.

ing an in-phase voltage, BC , to compensate for the voltage drop and bring the terminal voltage at B to a desired value. Figure 32 is a simplified sketch of a regulating transformer for voltage control, using an exciting autotransformer with automatic tap changing equipment indicated by the arrows.

Consider three systems interconnected with each other so that the interconnections from A to B , from B to C , and from C to A form a closed loop, as in Fig. 33 (a). An

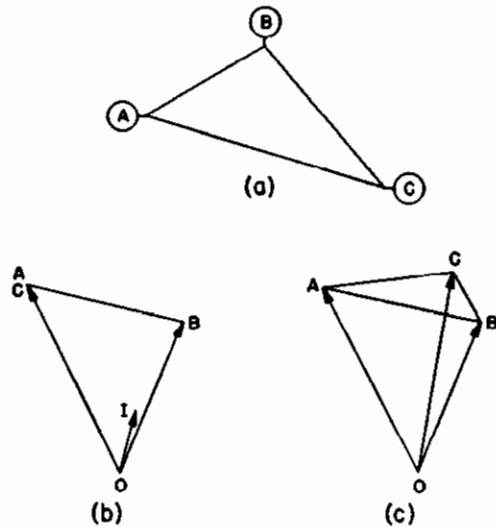

Fig. 33—Power interchange with three interconnected systems.

entirely new element enters, and adjustment of governors will not entirely control the flow of power over any one of the interconnecting lines. An attempt to adjust load on the tie between two systems results in a change of load on the other two tie lines. With the tie line from B to C open, and with power transmitted from A to B , the terminal voltages of A and C will be equal and in phase, with no power being transmitted from A to C , or vice versa (see Fig. 33 (b)). There now exists between B and C a difference in voltage and a difference in phase angle. If the tie line between B and C is closed under these conditions there is a redistribution of power flow between A and B , a part going over the line from A to B , and a part of the power going from A to B over the lines $A-C$ and $C-B$ (see Fig. 33 (c)). The distribution of power, both kw and reactive kva between the various lines is determined solely by the relative impedances of the interconnecting lines.

If at the time of closing $B-C$ an adjustment of transformer taps were made, or a regulating transformer for voltage control were inserted in the loop, it would be possible to make the voltage at C equal in magnitude to that at B but it would not have the same phase relationship. There would still be a flow of power from A to C and from C to B .

Conditions similar to that just described occur on interconnected systems involving loop circuits. To control the circulation of kw and prevent overloading certain lines it is often necessary to introduce a quadrature voltage, any place in the loop, by the use of a regulating transformer for phase-angle control. This differs from the usual star-

delta power transformation in that the angle of phase shift of current and voltage is not fixed but depends on the tap position. Figure 34 is a schematic diagram of a typical regulating transformer for phase angle control.

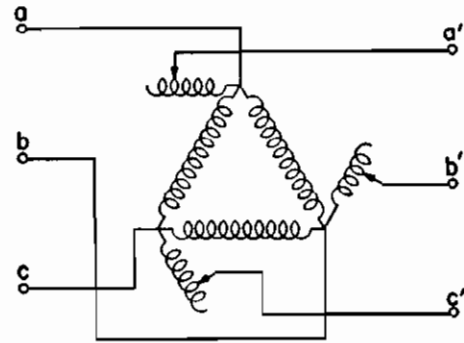

Fig. 34—Regulating transformer for phase-angle control.

In general the distribution of real power flow over the various interconnections found in loop circuits can be controlled by regulators for phase-angle control. The flow of reactive kva can be controlled by regulators for voltage control. The preceding statements follow from the fact that transmission-circuit impedances are predominantly reactive. The voltage regulator introduces a series in-phase voltage into the loop, and quadrature current (reactive kva) is circulated around the loop since the impedances are reactive. The regulator for phase-angle control introduces a quadrature series voltage in the loop resulting in the flow of currents lagging the impressed voltage by nearly 90 degrees, or the circulation of in-phase currents (kw).

For the case of correcting the voltage for line drop, a simple voltage control equipment can be used. This simply adds or subtracts a voltage in phase with the system voltage. For the case of phase-angle control, the equipment can be identical except the voltage selected to add or subtract is in quadrature. As the earlier discussion showed, there are cases where both voltage and phase angle control

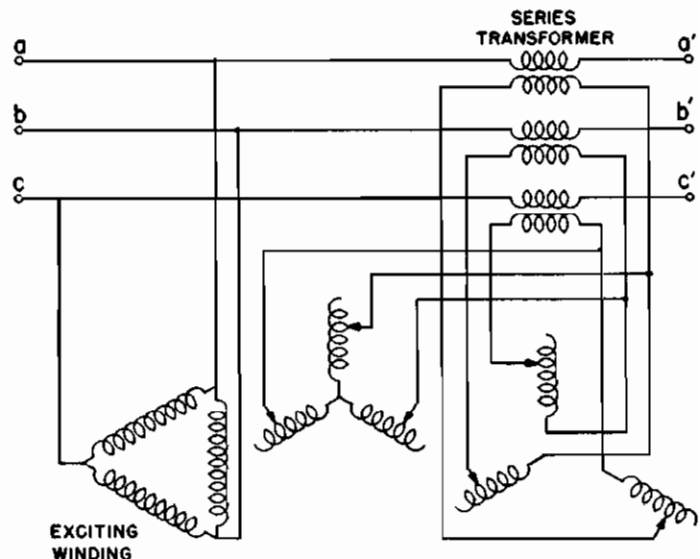

Fig. 35—Regulating transformer for independent phase-angle and voltage control.

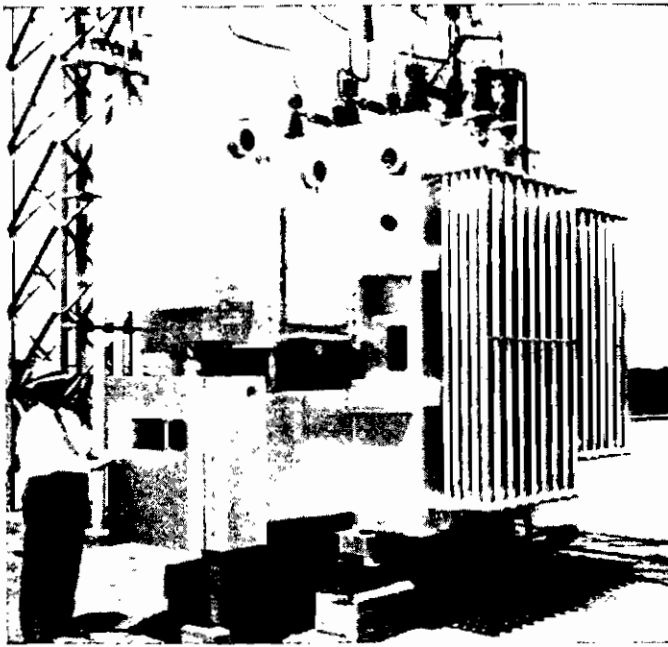

Fig. 36—Regulating transformer for voltage control, rated 20 000 kva, 12.47 kv, plus or minus 10 percent.

are required. There are a number of combinations of connections to accomplish this, one of them being shown in Fig. 35. Where the voltage and phase angle bear a close relation, one mechanism may suffice. However, where completely independent control is desired, two mechanisms with two regulating windings and one series winding, or with one regulating winding and two series windings are necessary. If it is desired to close the loop, and the flow of both real and reactive power over the various lines forming the loop must be controlled, the economical location for the control equipment is at the point of lowest load to be transferred. This may dictate the location in a loop, unless when in tying several companies together the boundary between systems determines the location. The voltage to be added or the phase-angle shift that must be obtained can be determined by calculation, considering the impedances of the tie line and the load conditions in the loop. When such calculations become involved, the use of the network calculator provides a quick and accurate tool for obtaining the solution.

Several common connections used for regulating transformers providing voltage control, phase angle control, or combined voltage and phase angle control, are tabulated in the Appendix under Equivalent Circuits of Power and Regulating Transformers. The equivalent circuits of the regulating transformers to positive-, negative-, and zero-sequence are given. It should be noted that the equivalent circuits for phase-angle control regulators involve an ideal transformer providing a phase shift of voltage and current. Positive-sequence voltage and current are always shifted by the *same* angle in the *same* direction. The angular shift for negative-sequence voltage and current is always equal to the angular shift for positive-sequence, but is in the *opposite* direction. Zero-sequence currents and voltages do not undergo an angular shift in being transformed. For ex-

ample, refer to F-7 in Table 7 of the Appendix, which is the regulating transformer for phase-angle control shown in Fig. 34.

For positive-sequence, neglecting regulator impedance:

$$E_1' = N \epsilon^{j\alpha} E_1 = \sqrt{1+3n^2} \epsilon^{j\alpha} E_1 \quad (63)$$

$$I_1' = \frac{1}{N} \epsilon^{j\alpha} I_1 = \frac{1}{\sqrt{1+3n^2}} \epsilon^{j\alpha} I_1 \quad (64)$$

where

$$\alpha = \tan^{-1} \sqrt{3}n$$

For negative-sequence, neglecting regulator impedance:

$$E_2' = N \epsilon^{-j\alpha} E_2 = \sqrt{1+3n^2} \epsilon^{-j\alpha} E_2 \quad (65)$$

$$I_2' = \frac{1}{N} \epsilon^{-j\alpha} I_2 = \frac{1}{\sqrt{1+3n^2}} \epsilon^{-j\alpha} I_2 \quad (66)$$

For zero-sequence, neglecting regulator impedance:

$$E_0' = E_0 \quad (67)$$

$$I_0' = I_0 \quad (68)$$

For this regulator zero-sequence voltage and current are not transformed; I_0 flows through the regulator as though it were a reactor.

It happens with several connections of regulating transformers that zero-sequence voltages and currents are not transformed at all, as in F-7; or are transformed with a different transformation ratio than for positive- or negative-sequence quantities as in G-1. This phenomenon, and the use of the sequence equivalent circuits for regulating transformers has been discussed in papers by Hobson and Lewis², and by J. E. Clem.³

XIV. EXCITING AND INRUSH CURRENTS

If normal voltage is impressed across the primary terminals of a transformer with its secondary open-circuited, a small exciting current flows. This exciting current consists of two components, the loss component and the magnetizing component. The loss component is in phase with the impressed voltage, and its magnitude depends upon the no-load losses of the transformer. The magnetizing component lags the impressed voltage by 90 electrical degrees, and its magnitude depends upon the number of turns in the primary winding, the shape of the transformer saturation curve and the maximum flux density for which the transformer was designed. A brief discussion of each of these components follows:

34. Magnetizing Component of Exciting Current

If the secondary of the transformer is open, the transformer can be treated as an iron-core reactor. The differential equation for the circuit consisting of the supply and the transformer can be written as follows:

$$e = Ri + n_1 \frac{d\phi}{dt} \quad (69)$$

where, e = instantaneous value of supply voltage

i = instantaneous value of current

R = effective resistance of the winding

ϕ = instantaneous flux threading primary winding

n_1 = primary turns

Normally the resistance, R , and the exciting current, i , are small. Consequently the Ri term in the above equation has little effect on the flux in the transformer and can, for the purpose of discussion, be neglected. Under these conditions Eq. (69) can be rewritten:

$$e = n_1 \frac{d\phi}{dt} \quad (70)$$

If the supply voltage is a sine wave voltage,

$$e = \sqrt{2}E \sin(\omega t + \lambda), \quad (71)$$

where, E = rms value of supply voltage

$$\omega = 2\pi f$$

Substituting in Eq. (70)

$$\sqrt{2}E \sin(\omega t + \lambda) = n_1 \frac{d\phi}{dt}$$

Solving the above differential equation,

$$\phi = -\frac{\sqrt{2}E}{\omega n_1} \cos(\omega t + \lambda) + \phi_t \quad (72)$$

In this solution, $-\frac{\sqrt{2}E}{\omega n_1} \cos(\omega t + \lambda)$ is the normal steady-state flux in the transformer core. The second term, ϕ_t , represents a transient component of flux the magnitude of which depends upon the instant at which the transformer is energized, the normal maximum flux and the residual flux in the core at the time the transformer is

energized. Under steady-state conditions this component is equal to zero; the magnitude of ϕ_t is discussed in Sec. 38.

From Eq. (72) it can be seen that the normal steady-state flux is a sine wave and lags the sine wave supply voltage by 90 degrees. The supply voltage and the normal flux are plotted in Fig. 37 as a function of time.

If there were no appreciable saturation in the magnetic circuit in a transformer, the magnetizing current and the flux would vary in direct proportion, resulting in a sinusoidal magnetizing current wave in phase with the flux. However, the economic design of a power transformer requires that the transformer iron be worked at the curved part of the saturation curve, resulting in appreciable saturation. Under this condition the magnetizing current is not a sine wave, and its shape depends upon the saturation characteristics (the B - H curve) of the transformer magnetic circuit. The shape of the current wave can be determined graphically as shown in Fig. 38. In Fig. 38(b) are shown the impressed voltage and the flux wave lagging the voltage by 90 degrees. For any flux the corresponding value of current can be found from the B - H curve. Following this procedure the entire current wave can be plotted. The current found in this manner does not consist of magnetizing current alone but includes a loss component required to furnish the hysteresis loss of the core. However, this component is quite small in comparison to the magnetizing component and has little effect on the maximum value of the total current.

A study of Fig. 38 shows that although the flux is a sine wave the current is a distorted wave. An analysis of this current wave shows that it contains odd-harmonic components of appreciable magnitude; the third harmonic component is included in Fig. 38. In a typical case the harmonics may be as follows: 45 percent third, 15 percent fifth, three percent seventh, and smaller percentages of higher frequency. The above components are expressed in percent of the equivalent sine wave value of the total exciting current. These percentages of harmonic currents will not change much with changes in transformer terminal voltage over the usual ranges in terminal voltage. In Fig. 39 are shown the variations in the harmonic content of the exciting current for a particular grade of silicon steel.

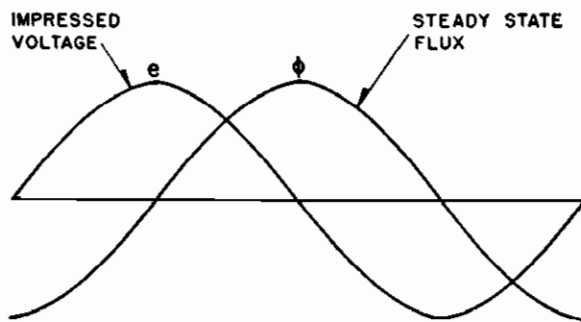

Fig. 37—Impressed voltage and steady-state flux.

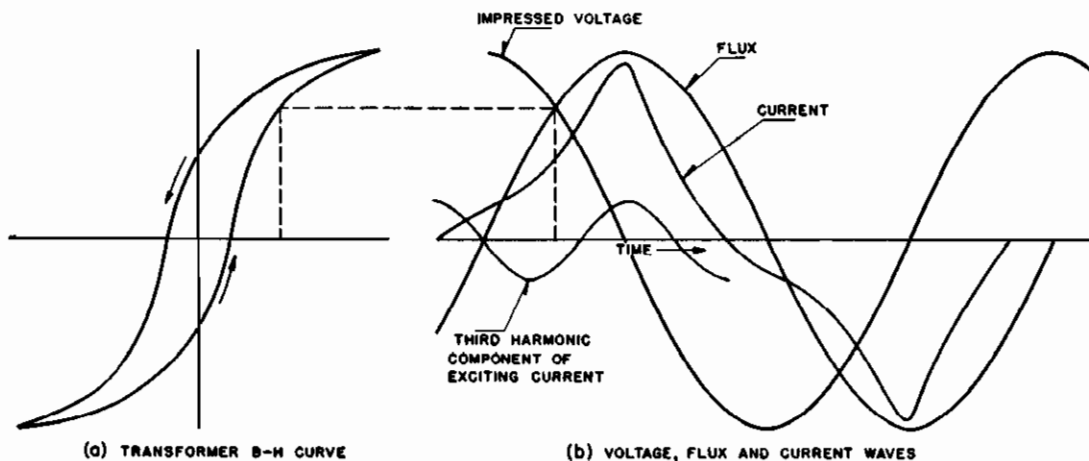

Fig. 38—Graphical method of determining magnetizing current.

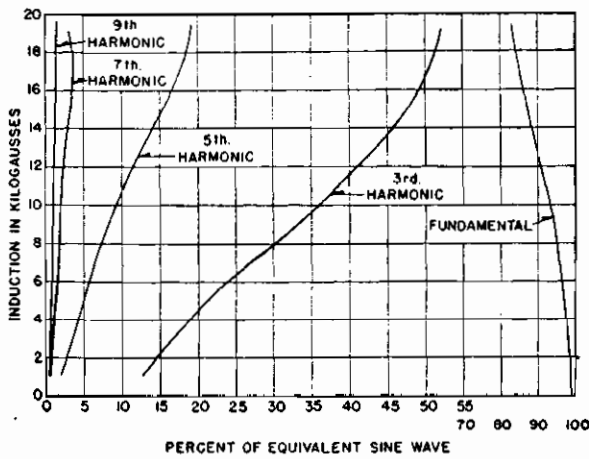

Fig. 39—Harmonic content of exciting current for a particular grade of silicon steel.

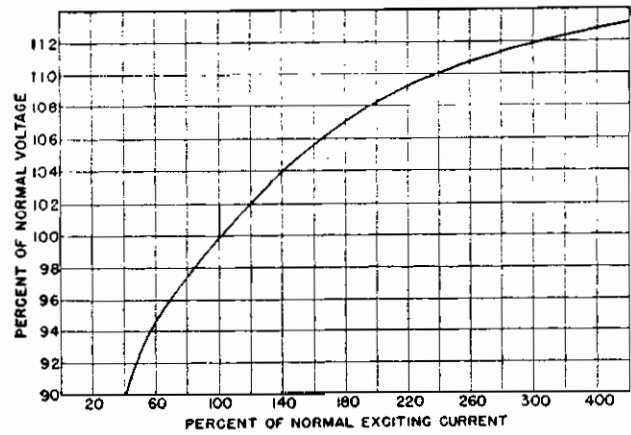

Fig. 40—Exciting current vs. terminal voltage. The above curve applies for one particular design of transformer; the shape of the curve may vary considerably depending upon the grade of steel and the transformer design.

35. Loss Component of Exciting Current

The no-load losses of a transformer are the iron losses, a small dielectric loss, and the copper loss caused by the exciting current. Usually only the iron losses, i.e., hysteresis and eddy current losses, are important. These losses depend upon frequency, maximum flux density, and the characteristics of the magnetic circuit.

In practice the iron losses are determined from laboratory tests on samples of transformer steel. However, the formulas given below are useful in showing the qualitative effect of the various factors on loss.

$$\begin{aligned}
 \text{Iron loss} &= W_h + W_e & (73) \\
 W_h &= K_h f B_{\max}^x \text{ watts per lb} \\
 W_e &= K_e f^2 t^2 B_{\max}^2 \text{ watts per lb} \\
 W_h &= \text{hysteresis loss} \\
 W_e &= \text{eddy current loss} \\
 f &= \text{frequency} \\
 t &= \text{thickness of laminations} \\
 B_{\max} &= \text{maximum flux density}
 \end{aligned}$$

K_h , K_e , and x are factors that depend upon the quality of the steel used in the core. In the original derivation of the hysteresis loss formula by Dr. Steinmetz, x was 1.6. For modern steels x may have a value as high as 3.0. The iron loss in a 60-cycle power transformer of modern design is approximately one watt per pound. The ratio of hysteresis loss to eddy current loss will be on the order of 3.0 with silicon steel and $\frac{2}{3}$ with oriented steel. These figures should be used as a rough guide only, as they vary considerably with transformer design.

36. Total Exciting Current

As discussed above, the total exciting current of a transformer includes a magnetizing and a loss component. The economic design of a transformer dictates working the iron at the curved part of the saturation curve at normal voltage; hence any increase in terminal voltage above normal will greatly increase the exciting current. In Fig. 40 the exciting current of a typical transformer is given as a function of the voltage applied to its terminals. The exciting current increases far more rapidly than the term-

inal voltage. For example, 108-percent terminal voltage results in 200-percent exciting current.

37. Typical Magnitudes of Exciting Current

The actual magnitudes of exciting currents vary over fairly wide ranges depending upon transformer size, voltage class, etc. In Table 13 are given typical exciting currents for power transformers. The exciting currents vary directly with the voltage rating and inversely with the kva rating.

TABLE 13
TYPICAL EXCITING CURRENT VALUES FOR SINGLE-PHASE POWER TRANSFORMERS
(In percent of full load current)

The following values should be considered as very approximate for average standard designs and are predicated on prevailing performance characteristics. Test values will as a rule come below these values but a plus or minus variation must be expected depending upon purchaser's requirements. Should closer estimating data be required, the matter should be referred to the proper manufacturer's design engineers.

Three-phase KVA	Voltage Class (Full Insulation)						
	2.5 Kv	15 Kv	25 Kv	69 Kv	138 Kv	161 Kv	230 Kv
500	3.7%	3.7%	3.8%	4.9%			
1 000	3.3	3.3	3.6	4.3			
2 500	3.1	3.2	3.8			
5 000	2.8	3.1	2.5%	4.1%	
10 000	3.0	3.1	2.4	3.6	4.0%*
25 000	2.2	2.4	3.1	3.9	3.5 *
50 000	3.1	3.9	2.8 *

*Reduced Insulation.

38. Inrush Current

When a transformer is first energized, a transient exciting current flows to bridge the gap between the conditions existing before the transformer is energized and the conditions dictated by steady-state requirements. For any given transformer this transient current depends upon the magnitude of the supply voltage at the instant the transformer is energized, the residual flux in the core,

and the impedance of the supply circuit. Often the magnitude of this transient current exceeds full-load current and may reach 8 to 10 times full-load current. These high inrush currents are important principally because of their effect on the operation of relays used for differential protection of transformers.

In studying the phenomena that occur when a transformer is energized it is more satisfactory to determine the flux in the magnetic circuit first and then derive the current from the flux. This procedure is preferable because the flux does not depart much from a sine wave even though the current wave is usually distorted.

The total flux in a transformer core is equal to the normal steady-state flux plus a transient component of flux, as shown in Eq. 72. This relation can be used to determine the transient flux in the core of a transformer immediately after the transformer is energized. As $\frac{\sqrt{2}E}{\omega n_1}$ represents the crest of the normal steady-state flux, Eq. (72) can be rewritten,

$$\phi = -\phi_m \cos(\omega t + \lambda) + \phi_t \tag{74}$$

where $\phi_m = \frac{\sqrt{2}E}{\omega n_1}$

At $t = 0,$
 $\phi_0 = -\phi_m \cos \lambda + \phi_{t0}$ (75)

where $\phi_0 =$ transformer residual flux
 $-\phi_m \cos \lambda =$ steady-state flux at $t = 0$
 $\phi_{t0} =$ initial transient flux.

In the above equation the angle λ depends upon the instantaneous value of the supply voltage at the instant the transformer is energized. If the transformer is energized at zero voltage, λ is equal to 0, whereas if the transformer is energized where the supply voltage is at a positive maximum value, λ is equal to 90 degrees. Assume that a transformer having zero residual flux is energized when the supply voltage is at a positive maximum. For these conditions ϕ_0 and $\cos \lambda$ are both equal to zero so ϕ_{t0} is also equal to zero. The transformer flux therefore starts out under normal conditions and there would be no transient. However, if a transformer having zero residual is energized at zero supply voltage the following conditions exist:

$$\begin{aligned} \lambda &= 0 \\ -\phi_m \cos \lambda &= -\phi_m \\ \phi_0 &= 0 \\ \phi_{t0} &= \phi_m \end{aligned}$$

Substituting in Eq. (74)

$$\phi = -\phi_m \cos(\omega t) + \phi_m \tag{76}$$

The flux wave represented by Eq. (76) is plotted in Fig. 41a. The total flux wave consists of a sinusoidal flux wave plus a d-c flux wave and reaches a crest equal to twice the normal maximum flux. In this figure the transient flux has been assumed to have no decrement; if loss is considered the transient flux decreases with time and the crest value of the total flux is less than shown. In Fig. 41 (b) similar waves have been plotted for a transformer having 60 percent positive residual flux and energized at zero supply voltage. Sixty percent residual flux has been

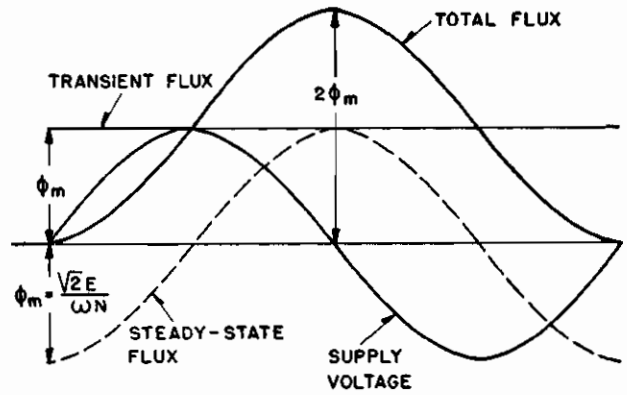

(a) PRIMARY CLOSED AT ZERO VOLTAGE—ZERO RESIDUAL FLUX.

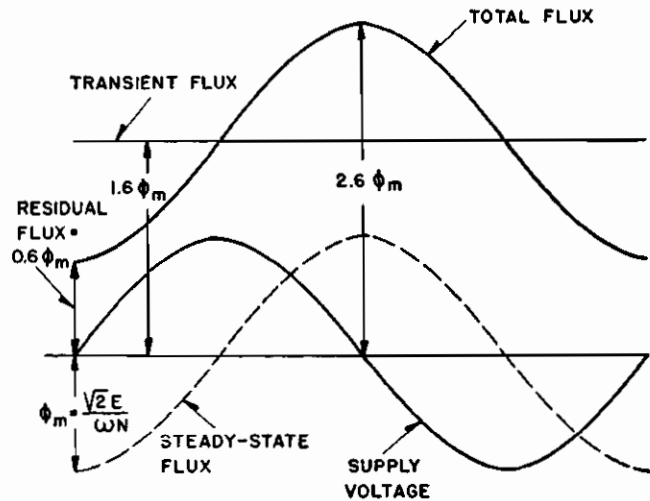

(b) PRIMARY CLOSED AT ZERO VOLTAGE—60% POSITIVE RESIDUAL FLUX.

Fig. 41—Transformer flux during transient conditions.

assumed for illustration only. Flux waves for any other initial conditions can be calculated in a similar manner using Eq. (74).

39. Determination of Current Inrush

After the flux variation has been determined by the method described, the current wave can be obtained graphically as shown in Fig. 42. In the case illustrated it was assumed that a transformer having zero residual flux was energized at zero supply voltage; the flux therefore is equal to twice normal crest flux. For any flux the corresponding current can be obtained from the transformer $B-H$ curve. Although the maximum flux is only twice its normal value, the current reaches a value equal to many times the maximum value of the normal transformer exciting current. This high value of current is reached because of the high degree of saturation of the transformer magnetic circuit.

In the above discussion loss has been neglected in order to simplify the problem. Loss is important in an actual transformer because it decreases the maximum inrush current and reduces the exciting current to normal after a

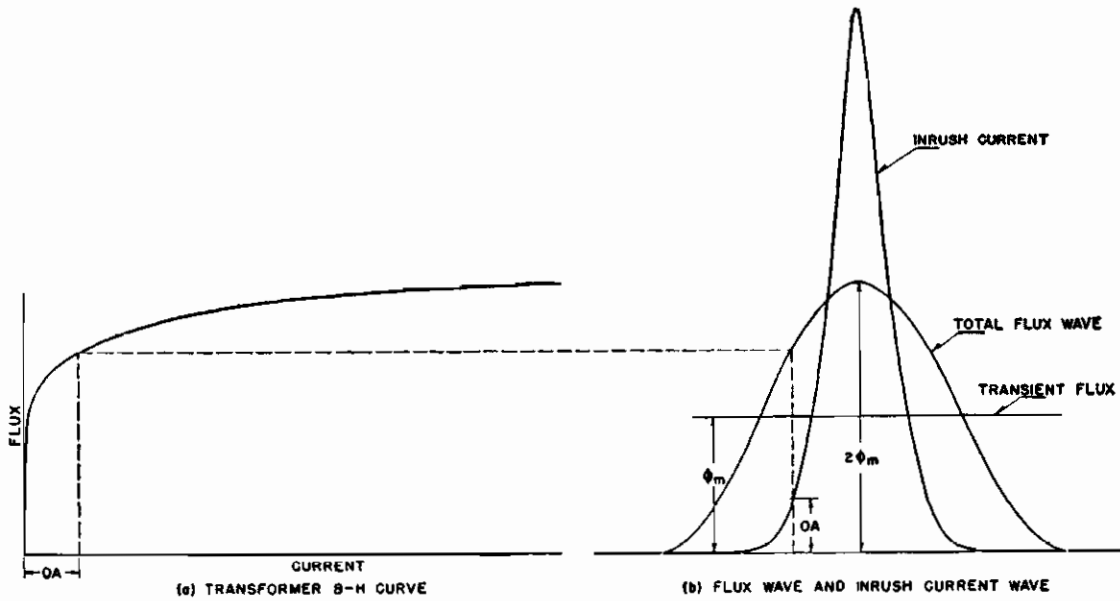

Fig. 42—Graphical method of determining inrush current.

period of time. The losses that are effective are the resistance loss of the supply circuit and the resistance and stray losses in the transformer. Figure 43 is an oscillogram of a typical exciting-current inrush for a single-phase transformer energized at the zero point on the supply voltage wave.⁹ The transient has a rapid decrement during the first few cycles and decays more slowly thereafter. The damping coefficient, R/L , for this circuit is not constant because of the variation of the transformer inductance with saturation. During the first few current peaks, the degree of saturation of the iron is high, making L low. The inductance of the transformer increases as the saturation

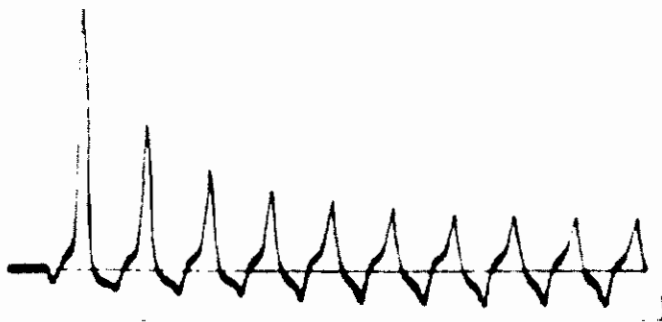

Fig. 43—Current inrush for a particular transformer energized at zero voltage.

decreases, and hence the damping factor becomes smaller as the current decays.

40. Estimating Inrush Currents

The calculation of the inrush current to a power transformer requires considerable detailed transformer design information not readily available to the application engineer. For this reason reference should be made to the manufacturer in those few cases where a reasonably accurate estimate is required. An order of magnitude of

TABLE 14—APPROXIMATE INRUSH CURRENTS TO 60-CYCLE POWER TRANSFORMERS ENERGIZED FROM THE HIGH-VOLTAGE SIDE

Transformer Rating Kva	Core Form	Shell Form
2000	5-8	
10 000	4-7	2.5-5
20 000		2.0-4

Note: The crest inrush currents are expressed in per unit of crest full-load current.

inrush currents to single-phase, 60-cycle transformers can be obtained from the data in Table 14. The values given are based on the transformer being energized from the high-voltage side at the instant the supply voltage passes through zero. Energizing a core-form transformer from the low-voltage side may result in inrush currents approaching twice the values in the table. The per unit inrush current to a shell-form transformer is approximately the same on the high- and low-voltage sides.

The inrush currents in Table 14 are based on energizing a transformer from a zero-reactance source. When it is desired to give some weight to source reactance, the inrush current may be estimated from the relation

$$I = \frac{I_0}{1 + I_0 X} \tag{77}$$

where

I_0 = Inrush current neglecting supply reactance in per unit of rated transformer current.

X = Effective supply reactance in per unit on the transformer kva base.

XV. THIRD-HARMONIC COMPONENT OF EXCITING CURRENT

41. Suppression of the Third-Harmonic Component

As discussed in connection with Fig. 39, the exciting current of a transformer contains appreciable harmonic

current. The third harmonic is by far the largest harmonic component, being as high as 40 to 50 percent of the equivalent sine-wave exciting current.

If the flux in a transformer magnetic circuit is sinusoidal, the exciting current must contain a third-harmonic component. If this component cannot flow, because of transformer or system connections, the flux will contain a third-harmonic component. The third-harmonic flux will, in turn, induce a third-harmonic voltage in the transformer windings. The magnitude of the third-harmonic voltage induced in a transformer winding, when the third-harmonic current is suppressed, will vary between 5 and 50 percent depending upon the type of transformers used. With single-phase transformers or with three-phase shell-form transformers the third-harmonic voltages may be as high as 50 percent of the fundamental-frequency voltage. In a three-phase core-form transformer the reluctance of the third-harmonic flux path is high (see Sec. 56); consequently the third-harmonic flux in the transformer magnetic circuit is small even if the third-harmonic component of the exciting current is suppressed. The third-harmonic voltage induced is therefore small, usually not more than five percent.

In a three-phase system, the third-harmonic currents of each phase are in phase with each other and hence constitute a zero-sequence set of currents of triple frequency. Likewise, the third-harmonic voltages will constitute a zero-sequence set of voltages of triple frequency. Thus, although a third-harmonic voltage may be present in the line-to-neutral voltages, there can be no third-harmonic component in the line-to-line voltage. The paths permitting the flow of third-harmonic currents are determined by the system and transformer zero-sequence circuits.

It has been shown that third harmonics must occur in either the exciting current or the voltage of a transformer. The exciting current will take the shape imposed by the particular connections used. It is always preferable to have at least one delta-connected winding in a three-phase transformer bank. The delta connection will furnish a path for the flow of third-harmonic currents and will minimize the third-harmonic current in the external circuits. This is very desirable because third-harmonic currents in the external circuits may, under some conditions, cause telephone interference. A discussion of telephone

interference, as affected by transformer connections, is given in Chapter 23, Sec. 11.

42. Effect of Transformer Connections

The application of the above principles will be illustrated by consideration of a number of typical connections. In Fig. 44 is shown a three-phase transformer bank connected

TABLE 15—INFLUENCE OF TRANSFORMER CONNECTIONS ON THIRD-HARMONIC VOLTAGES AND CURRENTS

	SOURCE	TRANSFORMER CONNECTION		COMMENTS
		PRIM.	SEC.	
1	UNGROUNDED (SMALL CAPACITANCE TO GROUND, NO GROUNDED GENERATORS OR GROUNDED TRANSFORMER BANKS)			SEE NOTE 1
2				" " 1
3				" " 1,5
4				" " 1,5
5				" " 3
6				" " 3
7				" " 3
8				" " 3,6
9	GROUNDED (GROUNDED GENERATORS OR GROUNDED TRANSFORMER BANKS OR LARGE CAPACITANCE TO GROUND)			SEE NOTE 1
10				" " 2
11				" " 1,5
12				" " 2,5
13				" " 3
14				" " 4
15				" " 3
16				" " 3,6

Note:

1. The third-harmonic component of the exciting current is suppressed and so a third-harmonic component will be present in the transformer line-to-ground voltages.
2. The third-harmonic component of the exciting current flows over the line and may cause interference due to possible coupling with parallel telephone circuits.
3. The delta-connected winding furnishes a path for the third-harmonic exciting currents required to eliminate the third-harmonic voltages. No third-harmonic current will flow in the line between the source and the transformer and very little third-harmonic will be present in the system voltage.
4. The delta-connected winding furnishes a path for the third-harmonic exciting currents required to eliminate the third-harmonic voltages. Very little third-harmonic current will flow in the line and very little third-harmonic will be present in the system voltage.
5. If the capacitance-to-ground of the circuit connected to the transformer secondary is large, appreciable third-harmonic current can flow in the secondary windings. This factor will help decrease the magnitude of the third-harmonic voltages but may cause interference in telephone lines paralleling the secondary power circuits. The same comments would apply if other ground sources are connected to the secondary circuit. Resonance with the secondary capacitance may produce high harmonic voltages.
6. Some third-harmonic current can flow in the secondary windings if other ground sources are present on the secondary side of the transformer bank. The magnitude of this current will depend upon the impedance of the ground sources relative to the delta circuit impedance and is usually too small to cause trouble from telephone interference.

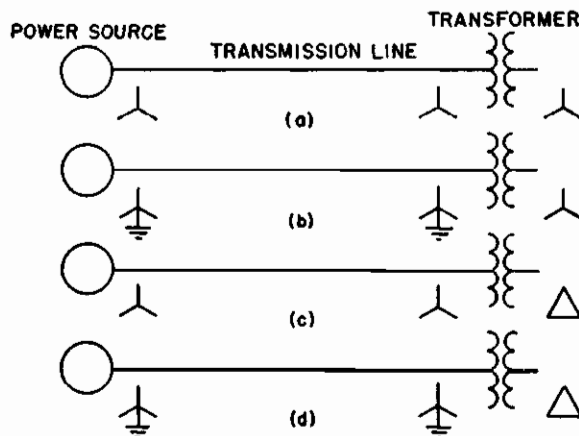

Fig. 44—Connections which influence the flow of third-harmonic exciting current.

to a transmission line, the line in turn being connected to a power source. If the star-star connection in Fig. 44(a) is used the third-harmonic component of the exciting current is suppressed and a third-harmonic component will therefore be present in the line-to-neutral voltages. With the primary neutral and the generator neutral grounded, as in Fig. 44(b), a path is furnished for the third-harmonic exciting currents. If the impedance of this path is low, little third-harmonic voltage will be present on the system. However, if the line is long and is closely coupled with telephone circuits, telephone interference may result. If the transformer bank is close to the power source no telephone interference should result from the use of this connection.

When a delta-connected winding is present in the transformer such as in Fig. 44(c) and (d), the delta connection furnishes a path for the third-harmonic currents required to eliminate the third-harmonic voltages. If the primary is ungrounded or the generator is ungrounded, no third-harmonic current will flow in the line. If the primary is grounded and the generator is also grounded, a little third-harmonic current can flow over the line. With this connection the magnitude of the third-harmonic current in the line depends upon the relative impedances of the supply circuit and the delta circuit. This current is usually too small to cause any troublesome interference.

The same general comments apply when three-winding transformers are used. If one winding is delta connected, little or no third-harmonic current will flow in the supply circuit and little or no third-harmonic voltage will be present on the system.

In Table 15 is given a summary of a number of typical transformer connections with a brief description of the effect of the connections on the third-harmonic currents and voltages.

XVI. TRANSFORMER NOISE

Transformer noise is a problem because of its disturbing effect upon people. Noise may arise from several sources of force induced vibrations, including

- (1) Magnetostriction, the small change in dimensions of ferromagnetic materials caused by induction.
- (2) Magnetic forces tending to pull jointed core members together.
- (3) Magnetic forces acting between two conductors, or between a conductor and a magnetic member.
- (4) Fans, pumps, or other transformer auxiliaries.

The most persistent of these sources of noise is magnetostriction, which depends upon flux density and cannot be eliminated by tight core construction. The only means of reducing magnetostrictive force now at hand is to reduce flux density in the core.

Noise arising from any of the sources listed above may be amplified by mechanical resonance in the tank or fittings, and careful design is necessary to avoid such reinforcement of the original sound.

Standards¹⁰ have been established for permissible sound pressure levels for various types of transformers, in terms of decibels referred to 0.002 dynes per square centimeter:

$$db = 20 \log_{10} \frac{P}{0.0002} \quad (78)$$

where P , the sound pressure, is expressed in dynes per square centimeter. Transformers designed to have sound levels below standard levels are available, but at extra cost because the magnetic material is worked at an induction below normal.

It is quite difficult to predetermine a sound level which will prove satisfactory in the surroundings where a new transformer is to be installed. Local conditions affect sound transmission, reflection, and resonance to a great degree, and these factors are hard to evaluate prior to transformer installation.

XVII. PARALLEL OPERATION OF TRANSFORMERS

43. Single-Phase Transformers

Transformers having different kva ratings may operate in parallel, with load division such that each transformer carries its proportionate share of the total load. To achieve accurate load division, it is necessary that the transformers be wound with the same turns ratio, and that the percent impedance of all transformers be equal, when each percentage is expressed on the kva base of its respective transformer. It is also necessary that the ratio of resistance to reactance in all transformers be equal, though most power transformers will likely be similar enough in this respect to permit calculations based on only the impedance magnitude.

The division of current between transformers having unequal turns ratios and unequal percent impedances may be calculated from an equivalent circuit similar to the one shown in Fig. 45. Either percent impedances or ohmic

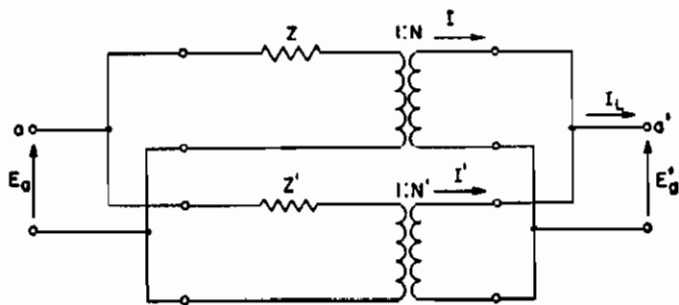

Fig. 45—Equivalent circuit for parallel connection of single-phase two-winding transformers.

impedances may be used in an equivalent circuit for parallel transformers. The circuit in Fig. 45 contains ohmic impedances and actual turns ratios; this method is perhaps more appropriate when the circuit involves unequal turn ratios, because the use of percent values in this type of circuit involves extra complications. Solution of this circuit, with a load current I_L assumed, will indicate the division of current between transformers. Also, solution of this circuit with total load current set equal to zero will indicate the circulating current caused by unequal transformer ratios. For satisfactory operation the circulating

current for any combination of ratios and impedances probably should not exceed ten percent of the full-load rated current of the smaller unit.

More than two transformers may of course be paralleled, and the division of load may be calculated from an extended equivalent circuit similar to the one in Fig. 45.

44. Three-Phase Transformer Banks

The same considerations apply for the parallel operation of symmetrical three-phase transformer banks as have been outlined for single-phase transformers. In addition it is necessary to make sure that polarity and phase-shift between high-voltage and low-voltage terminals are similar for the parallel units. A single-phase equivalent circuit may be set up on a line-to-neutral basis to represent one phase of a balanced three-phase bank, using the theory of symmetrical components.

When three-phase transformer banks having any considerable degree of dissymmetry among the three phases are to be analyzed, it is necessary either to set up a complete three-phase equivalent circuit, or to interconnect equivalent sequence networks in a manner to represent the unbalanced portion of the circuit according to the rules of symmetrical components.

45. Three-Winding Transformers

Currents flowing in the individual windings of parallel three-winding banks can be determined by solving an equivalent circuit, such as that shown in Fig. 46. The

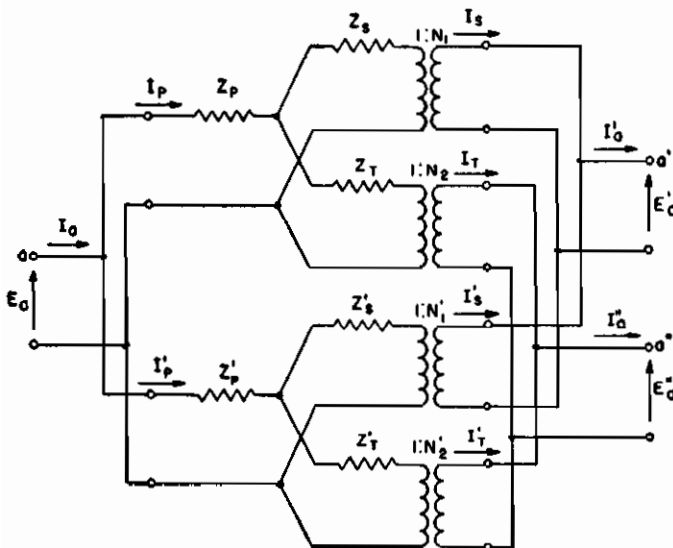

Fig. 46—Equivalent circuit for parallel connection of single-phase three-winding transformers.

terminal loads, as well as winding ratios and impedances, affect the division of currents among the windings of a three-winding transformer, so all these factors must be known before a solution is attempted.

46. Three-Winding Transformer in Parallel With Two-Winding Transformer

The equivalent circuit for a three-winding transformer paralleled with a two-winding transformer is given in Fig.

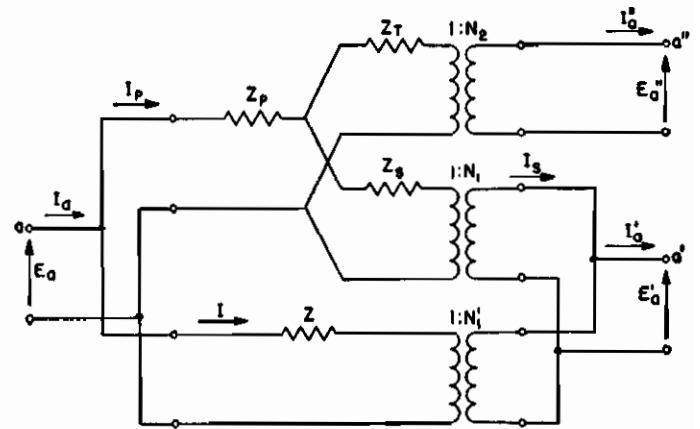

Fig. 47—Equivalent circuit for a single-phase three-winding transformer paralleled with a two-winding unit.

47. Division of currents may be calculated from this circuit, if the load currents I_a' and I_a'' are assumed.

Parallel operation of two such transformers is not usually satisfactory, since a change in tertiary load will alter the distribution of load between the other two windings. If the impedances are proportioned to divide the load properly for one load condition, the load division between transformers at some other loading is likely to be unsatisfactory. An exception is the case wherein the a'' circuit of Fig. 47 represents a delta tertiary winding in a three-phase bank, with no load connected to the tertiary; in this instance the transformers can be made to divide currents similarly at all loads.

It is possible to design a three-winding transformer so that the load taken from the tertiary winding does not seriously affect load division between the paralleled windings of the two transformers. If the impedance Z_p is made equal to zero, then current division at the a' terminals will be determined by Z_s and Z only, and this impedance ratio will remain independent of tertiary loading. It is difficult to obtain zero as the value for Z_p , particularly if this winding is of high voltage; however, values near zero can be obtained with special design at increased cost. Such a design may result in a value of Z_t which is undesirable for other reasons.

XVIII. TRANSFORMER PRICES

47. Two-Winding Type OA Transformers

Estimating prices for Type OA, oil-immersed, self-cooled, 60-cycle, two-winding transformers are given in Fig. 48. The estimating prices per kva are based on net prices as of December 1, 1949. As prices change frequently, the curves should be used principally for comparing the prices of different voltage classes, comparing banks made of single-phase and three-phase units, etc.

If the insulation level of the low-voltage winding is 15 kv, or higher, the prices in Fig. 48 should be corrected in accordance with Table 16. Price additions are also required when the rating of either the high- or low-voltage winding is 1000 volts and below.

Transformers designed for star connection of the high-voltage winding may be built with a lower insulation level

TABLE 16—ADDITIONS TO BE MADE TO PRICES IN FIG. 48
WHEN LOW-VOLTAGE WINDING INSULATION LEVEL IS 15 KV OR HIGHER

Low-Voltage Winding		Price Addition in Percent									
Insulation Class KV	Basic Impulse Levels-kv	Single-Phase Equivalent 55 C kva Self-Cooled Rating					3-Phase Equivalent 55 C kva Self-Cooled Rating				
		501 to 1800	1801 to 3500	3501 to 7000	7001 to 13500	13501 and above	501 to 3600	3601 to 7000	7001 to 14000	14001 to 27000	27001 and above
15	110	3½%	1½%	0%	0%	0%	3½%	1½%	0%	0%	0%
25	150	7	4	3	2	1	7	4	3	2	1
34.5	200	10	7	6	5	4	10	7	6	5	4
46	250	14	11	10	9	8	14	11	10	9	8
69	350	21	18	17	16	15	21	18	17	16	15
92	450	29	26	24	23	21	29	26	24	23	21
115	550	37	34	32	30	28	37	34	32	30	28
138	650	..	42	39	36	34	..	42	39	36	34
161	750	46	44	41	46	44	41

at the neutral end than at the line end of the winding. Table 17 summarizes the possible savings in cost with these designs. Reference should be made to section 16 for a discussion of the minimum insulation level that should be used at the transformer neutral.

48. Multi-Winding Units

If a multi-winding transformer is designed for simultaneous operation of all windings at their rated capacities, the price of the unit can be estimated from the curves given for two-winding transformers by using an equivalent

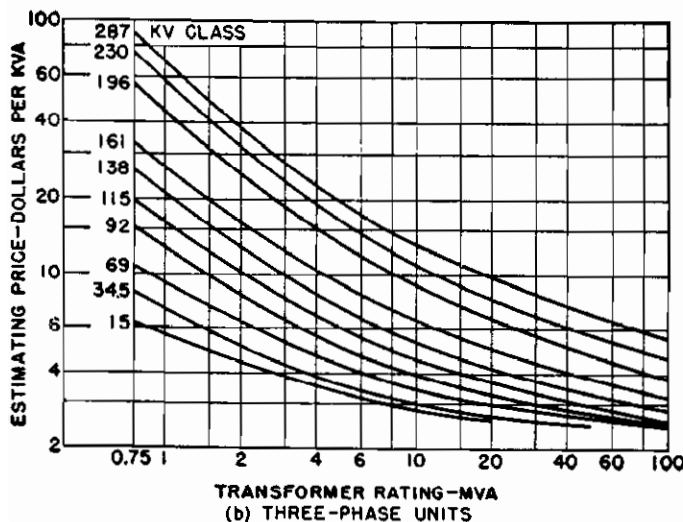
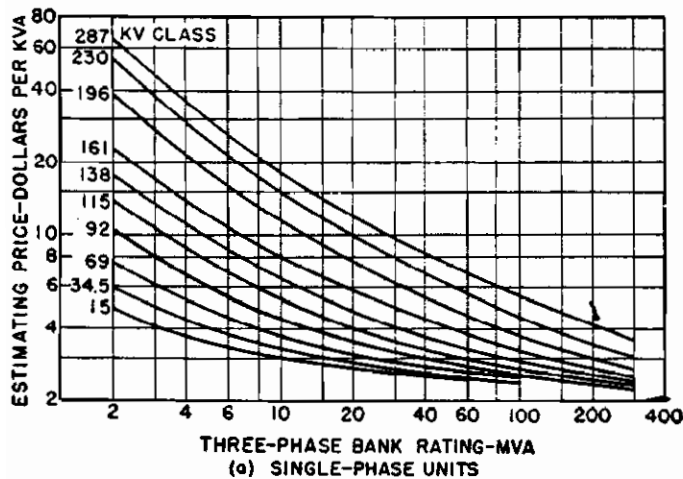

Fig. 48—Curve for estimating prices of oil-immersed, 60-cycle, two-winding, type OA power transformers.

TABLE 17—PRICE REDUCTION FOR GROUNDED NEUTRAL SERVICE

Winding Insulation Class at Line End	Insulation* Class at Neutral End	Price Reduction Percent
69	15	0
92	15	3.0
92	25-69	1.5
115	15	5.0
115	25-69	2.5
115	92	1.0
138	15	6.0
138	25-46	5.0
138	69-92	3.0
138	115	1.5
161	15	7.0
161	25-46	5.5
161	69-92	3.5
161	115-138	2.0
196	15	9.0
196	25-46	7.5
196	69-115	4.5
196	138-161	2.5
230	15	10.0
230	25-69	7.5
230	92-138	5.0
230	161	3.0
287	15	12.0
287	25-69	9.0
287	92-138	5.0
287	161-196	3.0

*Reference should be made to section 16 for a discussion of minimum permissible neutral insulation levels.

two-winding capacity equal to the sum of the rated capacities of the various windings divided by two. If a multi-winding transformer is not designed for simultaneous operation of all windings at their rated capacities, the price of the unit can be estimated from the curves given for two-winding transformers, using an equivalent two-winding capacity equal to

$$\text{Equivalent} = A + \frac{1}{4}(B - A) \quad (79)$$

Where $A = \frac{1}{2}$ (Sum of the simultaneous loadings).

$B = \frac{1}{2}$ (Sum of the maximum rated capacities of the various windings).

In addition, 5 percent must be added for three-winding transformers; 7.5 percent for four-winding transformers; and 10 percent for five-winding transformers.

49. Estimating Prices for Other Types of Cooling

Table 18 is a summary of the approximate cost of three-phase power transformers employing auxiliary cooling systems. All cost figures are expressed in per unit of OA

TABLE 18—RELATIVE COST OF THREE-PHASE TRANSFORMERS WITH SPECIAL COOLING

Each cost is in per unit, based on the cost of an OA transformer having a rating equal to the maximum of the special unit being considered^(c)

Type ^(a)	Three-Phase Bank Rating MVA ^(b)	Insulation Class—KV								
		15	34.5	69	92	115	138	161	196	230
OA/FA	1	1.08	1.07	1.05	1.05	1.05	1.06	1.08	1.06	1.07
	2	1.00	1.01	1.01	1.02	1.02	1.04	1.05	1.05	1.05
	5	0.92	0.95	0.95	0.96	0.97	0.99	0.99	0.99	1.00
	10	0.90	0.91	0.92	0.93	0.93	0.95	0.95	0.96	0.96
	20	0.88	0.88	0.90	0.90	0.90	0.92	0.91	0.92	0.93
	50		0.87	0.87	0.88	0.89	0.91	0.91	0.92	0.92
	100			0.87	0.88	0.89	0.90	0.90	0.91	0.91
OA/FA/FOA	20	0.74	0.75	0.77	0.78	0.79	0.81	0.80	0.83	0.83
	50		0.73	0.73	0.75	0.77	0.80	0.81	0.81	0.82
	100			0.72	0.74	0.75	0.76	0.78	0.81	0.80
FOA	20	0.66	0.67	0.71	0.73	0.75	0.77	0.78	0.81	0.82
	50		0.64	0.68	0.70	0.71	0.75	0.79	0.81	0.82
	100			0.66	0.67	0.67	0.68	0.71	0.75	0.75
OW	2	1.05	1.03	0.99	0.99	1.03	1.07	1.02	0.97	0.91
	5	0.91	0.92	0.92	0.92	0.93	0.97	0.96	0.93	0.91
	10	0.85	0.84	0.90	0.88	0.90	0.89	0.93	0.91	0.90
	20	0.82	0.84	0.87	0.88	0.89	0.88	0.91	0.90	0.90
	50		0.87	0.86	0.85	0.85	0.84	0.88	0.87	0.87
100			0.85	0.85	0.85	0.82	0.82	0.85	0.81	
FOW	20	0.60	0.61	0.65	0.67	0.69	0.71	0.71	0.74	0.75
	50		0.59	0.62	0.64	0.65	0.69	0.73	0.71	0.72
	100			0.60	0.61	0.62	0.62	0.65	0.69	0.69

(a) OA/FA—Oil-Immersed Self-Cooled/Forced-Air-Cooled.
 OA/FA/FAO—Triple-Rated, Self-Cooled/Forced-Air-Cooled/Forced-Oil-Cooled.
 FOA—Forced-Oil-Cooled with Forced-Air-Coolers.
 OW—Oil-Immersed Water Cooled.
 FOW—Forced-Oil Cooled with Water Coolers.
 (b) The MVA ratings tabulated for OA/FA and OA/FA/FOA units are the FA and the FOA ratings respectively.
 (c) Example: The cost of a 15 kv OA/FA three phase unit rated 10 000 kva (FA) is equal to 0.90 times the cost of a 15 kv OA three-phase unit rated 10 000 kva.

transformer cost, where the OA rating used to determine the base cost is equal to the highest rating of the force-cooled or specially-cooled unit. The kva ratings listed in the second column of Table 18 are the highest ratings of forced-cooled units; for example, the kva rating listed for OA/FA/FOA transformers is the FOA value.

XIX. REACTORS

50. Application of Current-Limiting Reactors

Current-limiting reactors are inductance coils used to limit current during fault conditions, and to perform this function it is essential that magnetic saturation at high current does not reduce the coil reactance. If fault current is more than about three times rated full load current, an iron core reactor designed to have essentially constant magnetic permeability proves overly expensive, therefore air core coils having constant inductance are generally used for current-limiting applications. A reactor whose inductance increased with current magnitude would be most effective for limiting fault current, but this characteristic has not been practically attained.

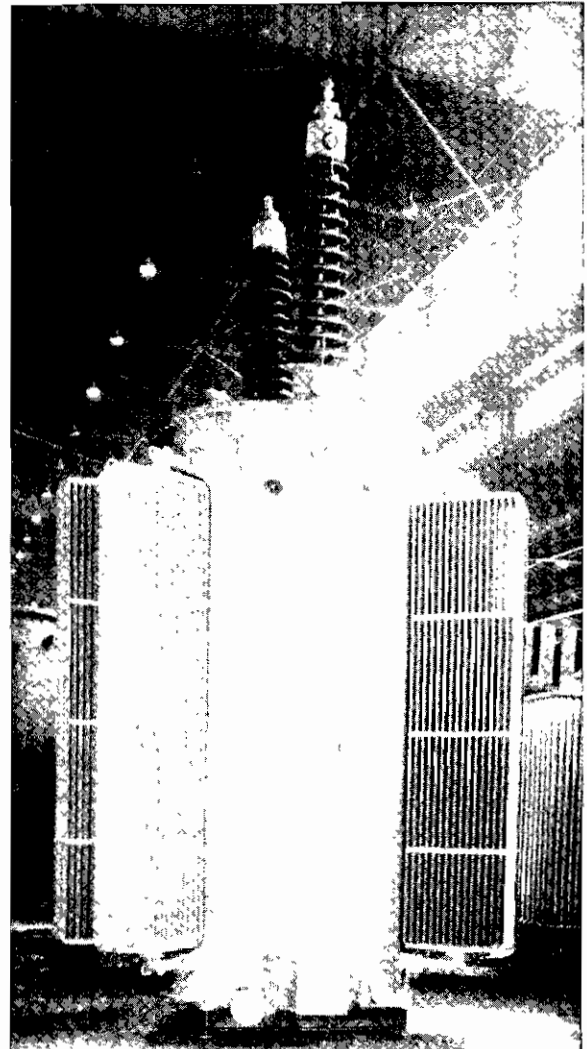

Fig. 49—Oil-immersed air-core reactor.

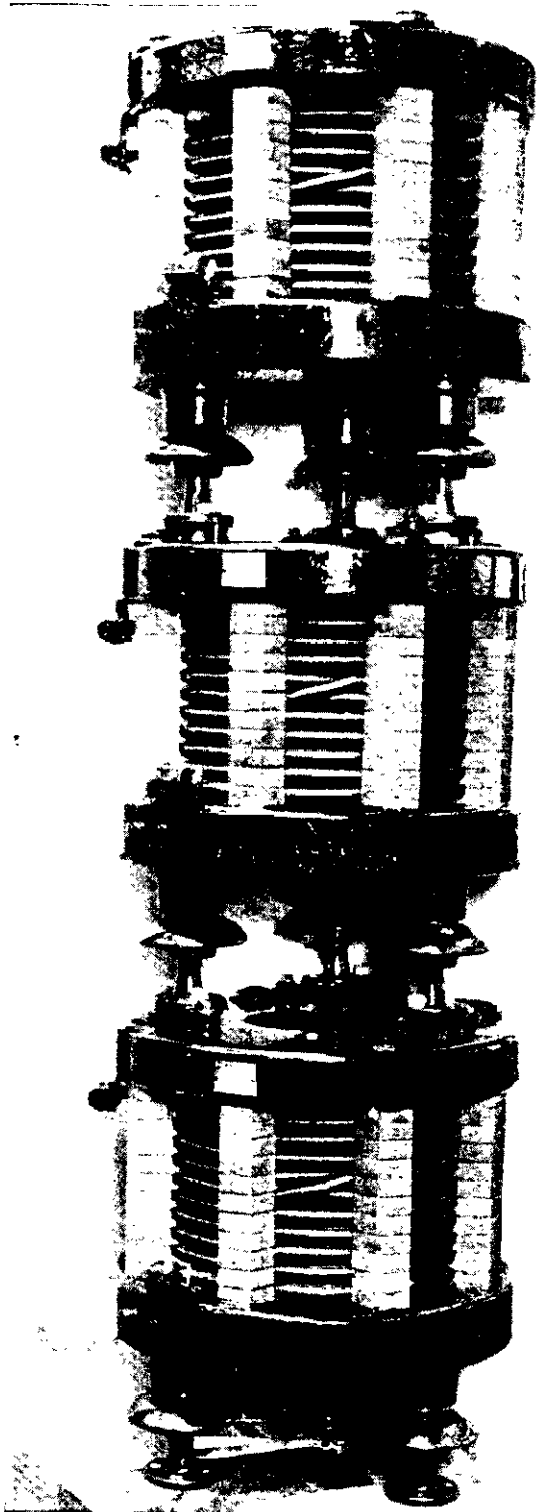

Fig. 50—Dry-type air-core reactor.

Air core reactors are of two general types, oil-immersed (Fig. 49) and dry-type (Fig. 50). Oil-immersed reactors can be cooled by any of the means commonly applied to power transformers. Dry-type reactors are usually cooled by natural ventilation but can also be designed with forced-air and heat-exchanger auxiliaries where space is at a premium.

Oil-immersed reactors can be applied to a circuit of any voltage level, for either indoor or outdoor installation. The advantages of oil-immersed reactors also include:

1. A high factor of safety against flashover.
2. No magnetic field outside the tank to cause heating or magnetic forces in adjacent reactors or metal structures during short-circuits.
3. High thermal capacity.

Dry-type reactors depend upon the surrounding air for insulation and cooling. Because of the required clearances and construction details necessary to minimize corona, these reactors are limited to 34.5 kv as a maximum insulation class. Free circulation of air must be maintained to provide satisfactory heat transfer. These coils should not be surrounded with closed circuits of conducting material because the mutual inductance may be sufficient to produce destructive forces when short-circuit current flows in the coil. Structures such as I-beams, channels, plates, and other metallic members, either exposed or hidden, should also be kept at a distance from the reactor even though they do not form closed circuits. A side clearance equal to one-third the outside diameter of the coil, and an end clearance of one-half the outside diameter of the coil will produce a temperature rise less than 40 C in ordinary magnetic steel. For the same size members, brass will have about the same rise, aluminum about one and one half times, and manganese steel about one-third the rise for ordinary magnetic steel. Reinforcing rods less than three-fourths inch in diameter which do not form a complete electrical circuit are not included in these limitations, because the insulation clearances from the reactor should be sufficient to avoid undue heating in such small metal parts.

In order to avoid excessive floor loading due to magnetic forces between reactors the spacing recommended by the manufacturer should be observed. Sometimes this spacing can be reduced by use of bracing insulators between units or using stronger supporting insulators and increasing the strength of the floor. This should always be checked with the manufacturer since bracing increases the natural period of vibration and may greatly increase the forces to be resisted by the building floors or walls.

51. Reactor Standards

The standard insulation tests for current-limiting reactors are summarized in Table 19.

Dry-type current-limiting reactors are built with Class B insulation and have an observable temperature rise by resistance of 80 C with normal continuous full-load current. Dry-type and oil-immersed current-limiting reactors are designed mechanically and thermally for not more than $33\frac{1}{3}$ times (3 percent reactive drop) normal full-load current for five seconds under short-circuit conditions.

52. Determination of Reactor Characteristics

When specifying a current-limiting reactor, information should be included on the following:

1. Indoor or outdoor service.
2. Dry- or oil-immersed type.
3. Single-phase or three-phase reactor.
4. Ohms reactance.

TABLE 19—STANDARD DIELECTRIC TESTS FOR CURRENT-LIMITING REACTORS

Insulation Class kv (a)	Low Frequency Tests ^(b)		Impulse Tests (Oil Type) ^(c)		
	Oil Type kv rms	Dry Type (c) kv rms	Chopped Wave		Full Wave kv crest
			Voltage kv crest	Min. Time to Flash-over in μ s	
1.2	12	12	54	1.5	45
2.5	17	25	69	1.5	60
5.0	21	30	88	1.6	75
8.66	29	40	110	1.8	95
15.0	36	60	130	2.0	110
23.0	60	85	175	3.0	150
34.5	80	115	230	3.0	200
46.0	105		290	3.0	250
69.0	160		400	3.0	350
92.0	210		520	3.0	450
115.0	260		630	3.0	550
138.0	310		750	3.0	650
161.0	365		865	3.0	750
196.0	425		1035	3.0	900
230.0	485		1210	3.0	1050
287.0	590		1500	3.0	1300
345.0	690		1785	3.0	1550

Notes:
 (a) Intermediate voltage ratings are placed in the next higher insulation class unless specified otherwise.
 (b) Turn-to-turn tests are made by applying these low-frequency test voltages, at a suitable frequency, across the reactor terminals; dry-type reactors for outdoor service require a turn-to-turn test voltage one-third greater than the tabulated values.
 (c) No standard impulse tests have been established for dry-type current-limiting reactors.

5. Continuous current rating, amperes.
6. Reactor rating in kva.
7. Voltage class.
8. Circuit characteristics:
 - (a) Single-phase or three-phase.
 - (b) Frequency.
 - (c) Line-to-line voltage.
 - (d) Type of circuit conductors.

Standardization of current ratings and ohmic reactances for current-limiting reactors is not yet completed, but semi-standard values are available and should be used where feasible in the preparation of reactor specifications.

53. Reactor Prices

The estimating prices included in this section should be used for comparative purposes only because reactor prices are subject to change from time to time.

Estimating prices for single-phase, 60-cycle, dry-type current-limiting reactors are given in Fig. 51 for kva ratings between 10 and 5000. Reactors for use in 1201 to 13 800 volt circuits may be estimated from the curve labeled "15 kv and below." The prices given apply to single-phase reactors with current ratings between 300 and 600 amperes. For current ratings below 300 amperes, price additions must be made in accordance with Table 20. When the current rating exceeds 600 amperes make a price addi-

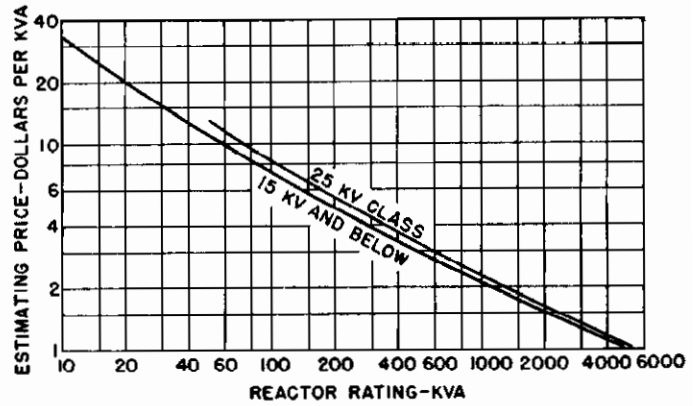

Fig. 51—Curve for estimating prices of single-phase, 60-cycle, dry-type current-limiting reactors.

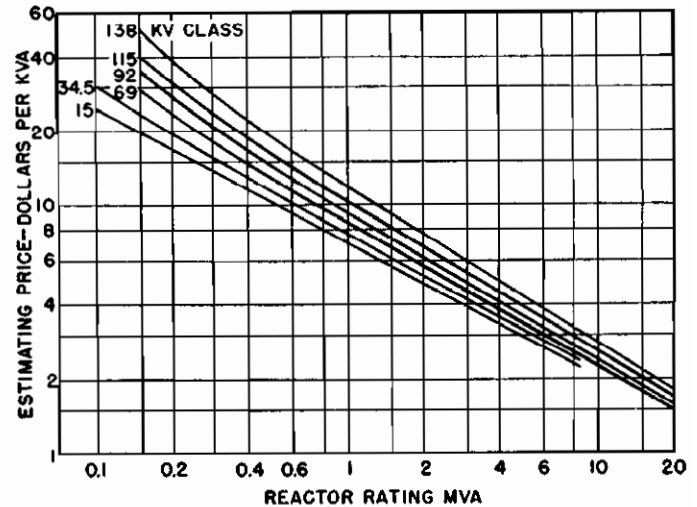

Fig. 52—Curve for estimating prices of single-phase, 60-cycle, oil-immersed current-limiting reactors.

tion of one percent for each 100 amperes, or fraction thereof, above 600 amperes.

Estimating prices for single-phase, 60-cycle, oil-immersed current-limiting reactors are given in Fig. 52 for insulation classes between 15 and 138 kv. For current ratings above 800 amperes make a price addition of two percent for each 100 amperes, or fraction thereof, above 800 amperes.

Estimating prices for 60-cycle, oil-immersed, self-cooled shunt reactors may be estimated by adding 10 percent to the prices given in Fig. 48 (a) for two-winding transformers.

TABLE 20—PRICE ADDITIONS FOR DRY-TYPE REACTORS RATED BELOW 300 AMPERES

Current Rating Amperes	Price Addition Percent
250-299	5
200-249	10
150-199	15
125-149	22
100-124	29
75- 99	36
50- 74	43

XX. EQUIVALENT CIRCUITS FOR SINGLE PHASE TRANSFORMERS

Representation of a transformer by an equivalent circuit is a commonly used method for determining its performance as a circuit element in complex power and distribution networks. Without the simplifications offered by the use of such equivalent circuits the handling of transformers with their complex array of leakage and mutual impedances would be a formidable problem.

For the purposes of calculating short circuit currents, voltage regulation, and stability of a power system, the normal magnetizing current required by transformers is neglected. Thus Figs. 2(c), (d), or (e), as the choice may be, will adequately represent a two-winding transformer for calculation purposes.

For three-, four-, and in general multi-winding transformers, an equivalent network can be always determined that will consist only of simple impedances (mutual impedances eliminated) and accurately represent the transformer as a circuit element. The impedances which can be most readily determined by test or by calculation are those between transformer windings taken two at a time, with other windings considered idle; therefore the impedances in an equivalent circuit can well be expressed in terms of these actual impedances between the transformer windings taken two at a time.

The number of independent impedances required in an equivalent circuit to represent a multi-winding transformer shall be, in general, equal to the number of all possible different combinations of the windings taken two at a time. Thus, one equivalent impedance is required to represent a two-winding transformer, three branch impedances for a three-winding transformer, and six independent branch impedances to represent a four-winding transformer.

Equivalent circuits for the two-winding transformer and auto-transformer are presented in sections 1 and 27, respectively. The following sections discuss the equivalent circuits for three-winding and four-winding transformers.

54. Equivalent Circuits for Three-Winding Transformer

The equivalent circuit for a transformer having three windings on the same core is shown in Fig. 53, where the magnetizing branches have been omitted. The number of turns in the *P*, *S*, and *T* windings are n_1 , n_2 , and n_3 , respectively. The equivalent circuit is shown in Fig. 53 (b) with all impedance in ohms on the *P* winding voltage base and with ideal transformers included to preserve actual voltage and current relationships between the *P*, *S*, and *T* windings. On the *P* winding voltage base:

$$\begin{aligned} Z_P &= \frac{1}{2} \left(Z_{PS} + Z_{PT} - \frac{1}{N_1^2} Z_{ST} \right) \\ Z_S &= \frac{1}{2} \left(\frac{1}{N_1^2} Z_{ST} + Z_{PS} - Z_{PT} \right) \\ Z_T &= \frac{1}{2} \left(Z_{PT} + \frac{1}{N_1^2} Z_{ST} - Z_{PS} \right) \end{aligned} \quad (80)$$

$$N_1 = \frac{n_2}{n_1}$$

$$N_2 = \frac{n_3}{n_1}$$

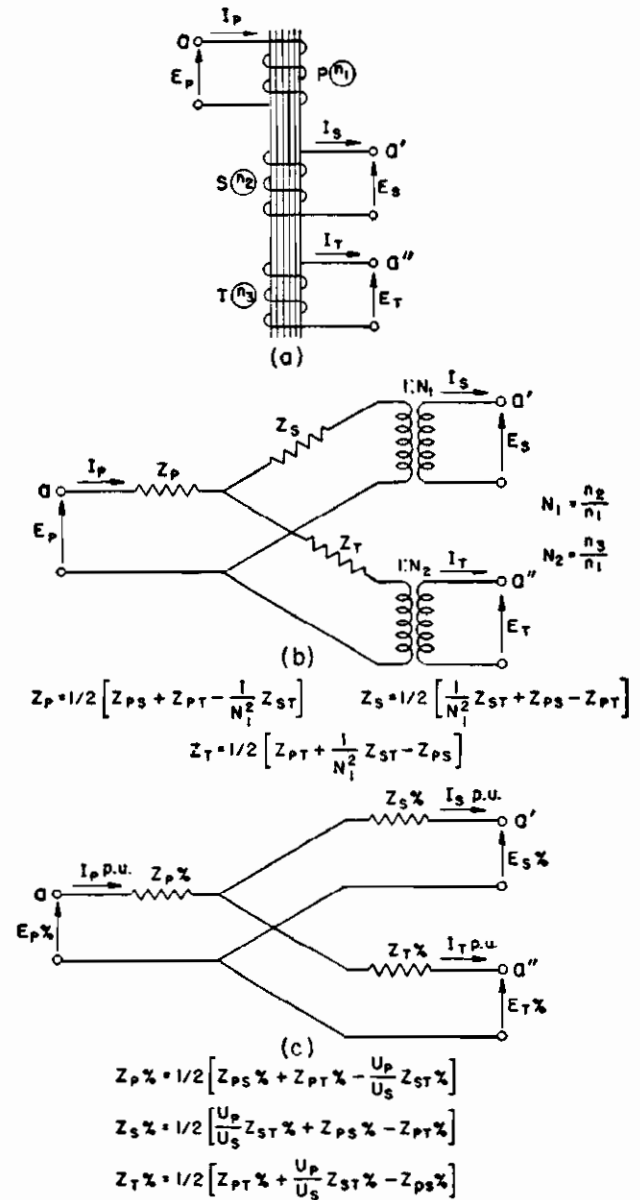

Fig. 53—Three-winding transformer.

- (a) winding diagram.
- (b) equivalent circuit in ohms.
- (c) equivalent circuit in percent.

Note that Z_P and Z_S as defined and used here differ from Z_P and Z_S in Eq. 10. The equivalent circuit expressed in percent is given in Fig. 53 (c) with all impedances referred to the kva of the *P* winding.

$$\begin{aligned} Z_P \% &= \frac{1}{2} \left(Z_{PS} \% + Z_{PT} \% - \frac{U_P}{U_S} Z_{ST} \% \right) \\ Z_S \% &= \frac{1}{2} \left(\frac{U_P}{U_S} Z_{ST} \% + Z_{PS} \% - Z_{PT} \% \right) \\ Z_T \% &= \frac{1}{2} \left(Z_{PT} \% + \frac{U_P}{U_S} Z_{ST} \% - Z_{PS} \% \right) \end{aligned} \quad (81)$$

The quantities can be expressed in percent on any arbitrary kva base, U_C , by multiplying each impedance by

the ratio $\frac{U_C}{U_P}$. The notation used is defined as follows:

U_P = kva of the P winding.

U_S = kva of the S winding.

U_T = kva of the T winding.

Z_{PS} = leakage impedance between the P and S windings as measured in ohms on the P winding with the S winding short-circuited and the T winding open-circuited.

$Z_{PS}\%$ = leakage impedance between the P and S windings, with the T winding open-circuited, expressed in percent on the kva and voltage of the P winding.

Z_{PT} = leakage impedance between the P and T windings as measured in ohms on the P winding with the T winding short-circuited and the S winding open-circuited.

$Z_{PT}\%$ = leakage impedance between the P and T windings, with the S winding open-circuited, expressed in percent on the kva and voltage of the P winding.

Z_{ST} = leakage impedance between the S and T windings as measured in ohms on the S winding with the T winding short-circuited and the P winding open-circuited.

$Z_{ST}\%$ = leakage impedance between the S and T windings, with the P winding open-circuited, expressed in percent on the kva and voltage of the S winding.

The equations given in Fig. 53 (b) and Fig. 53 (c) for Z_P , $Z_P\%$, etc., are derived from the relationships:

$$\begin{aligned} Z_{PS} &= Z_P + Z_S & Z_{PS}\% &= Z_P\% + Z_S\% \\ Z_{PT} &= Z_P + Z_T & Z_{PT}\% &= Z_P\% + Z_T\% \end{aligned} \quad (82)$$

$$Z_{ST} = N_1^2(Z_S + Z_T) \quad Z_{ST}\% = \frac{U_S}{U_P}(Z_S\% + Z_T\%)$$

also

$$\begin{aligned} Z_P &= R_P + jX_P \\ Z_{PS} &= R_{PS} + jX_{PS} = R_P + R_S + j(X_P + X_S) \\ Z_{PS}\% &= R_{PS}\% + jX_{PS}\% \text{ etc.,} \end{aligned} \quad (83)$$

where X_{PS} is the leakage reactance between the P and S windings (with T open-circuited); and R_{PS} is the total effective resistance between the P and S windings, as measured in ohms on the P winding with S short-circuited and T open-circuited. $R_{PS}\%$ and $X_{PS}\%$ are the respective quantities expressed in percent on the kva and voltage of the P winding.

The equivalent circuits completely represent the actual transformer as far as leakage impedances, mutual effects between windings, and losses are concerned (except exciting currents and no load losses). It is possible for one of the three legs of the equivalent circuit to be zero or negative.

55. Equivalent Circuits for Four-Winding Transformer

The equivalent circuit representing four windings on the same core, shown in Fig. 54 (a), is given in Fig. 54 (b) using ohmic quantities. This form is due to Starr^{11, 12} and

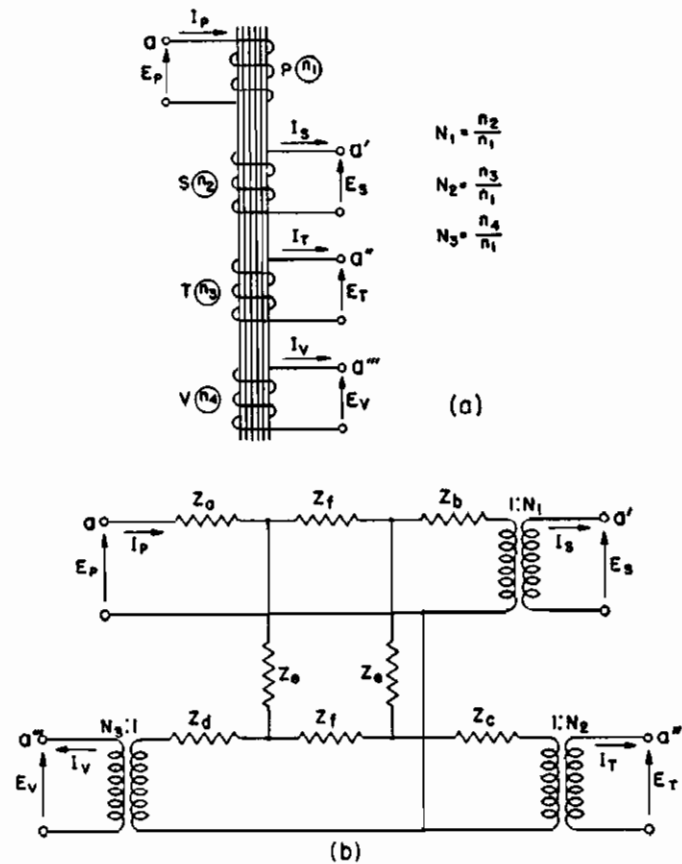

Fig. 54—Four-winding transformer.

(a) winding diagram.

(b) equivalent circuit.

here again the magnetizing branches are omitted. The branches of the equivalent circuit are related to the leakage impedances between pairs of windings as follows:

$$\begin{aligned} Z_a &= \frac{1}{2} \left(Z_{PS} + Z_{PV} - \frac{1}{N_1^2} Z_{SV} - K \right) \\ Z_b &= \frac{1}{2} \left(Z_{PS} + \frac{1}{N_1^2} Z_{ST} - Z_{PT} - K \right) \\ Z_c &= \frac{1}{2} \left(\frac{1}{N_1^2} Z_{ST} + \frac{1}{N_2^2} Z_{TV} - \frac{1}{N_1^2} Z_{SV} - K \right) \\ Z_d &= \frac{1}{2} \left(\frac{1}{N_2^2} Z_{TV} + Z_{PV} - Z_{PT} - K \right) \\ Z_e &= \sqrt{K_1 K_2} + K_1 \\ Z_f &= \sqrt{K_1 K_2} + K_2 \\ K &= \sqrt{K_1 K_2} = \frac{Z_c Z_f}{Z_e + Z_f} \end{aligned} \quad (84)$$

where,

$$K_1 = Z_{PT} + \frac{1}{N_1^2} Z_{SV} - Z_{PS} - \frac{1}{N_2^2} Z_{TV}$$

$$K_2 = Z_{PT} + \frac{1}{N_1^2} Z_{SV} - Z_{PV} - \frac{1}{N_2^2} Z_{ST}$$

The windings will ordinarily be taken in the order that makes K_1 and K_2 positive so that Z_e and Z_f will be positive. The leakage impedances are defined as before; for example, Z_{PS} is the leakage impedance between the P

and S windings as measured in ohms on the P winding with the S winding short-circuited and with the T and V windings open-circuited. The equivalent circuit in percent has the same form as Fig. 54 (b), omitting the ideal transformers.

$$Z_a\% = \frac{1}{2} \left(Z_{PS}\% + Z_{TV}\% - \frac{U_P}{U_S} Z_{SV}\% - K\% \right), \text{ etc.}$$

$$K_1\% = Z_{PT}\% + \frac{U_P}{U_S} Z_{SV}\% - Z_{PS}\% - \frac{U_P}{U_T} Z_{TV}\%, \text{ etc.} \quad (85)$$

Similar equations, derived from Eq. (84), apply for the other quantities in the equivalent circuit.

XXI. SEQUENCE IMPEDANCE CHARACTERISTICS OF THREE-PHASE TRANSFORMER BANKS

56. Sequence Equivalent Circuits

The impedance of three-phase transformer banks to positive-, negative-, and zero-sequence currents, and the sequence equivalent circuits, are given in the Appendix, under Equivalent Circuits for Power and Regulating Transformers. The equivalent circuits were developed by Hobson and Lewis^{2,13}. The same notation as defined in the early part of this chapter is used to denote leakage impedances in ohms and in percent.

The impedance to negative-sequence currents is always equal to the impedance to positive sequence currents, and the equivalent circuits are similar except that the phase shift, if any is involved, will always be of the same magnitude for both positive- and negative-sequence voltages and currents but in opposite directions. Thus, if the phase shift is $+\alpha$ degrees for positive-sequence, the phase shift for negative-sequence quantities will be $-\alpha$ degrees.

The impedance of a three-phase bank of two-winding transformers to the flow of zero-sequence currents is equal to the positive-sequence impedance for three-phase shell-form units (or for a bank made up of three single-phase units) if the bank is star-star with both star points ground-

ed. If the bank is connected star-delta, with the star point grounded, the zero-sequence impedance viewed from the star-connected terminals for shell-form units, or banks of three single-phase units, is equal to the positive-sequence impedance; the zero-sequence impedance viewed from the delta-connected terminals is infinite.

The impedance to the flow of zero-sequence currents in three-phase core-form units is generally lower than the positive-sequence impedance. Figure 55 illustrates that there is no return for the zero-sequence exciting flux in such a unit, except in the insulating medium, or in the tank and metallic connections other than the core. The flux linkages with the zero-sequence exciting currents are therefore low, and the exciting impedance to zero-sequence currents correspondingly low. Although the exciting impedance to positive-sequence currents may be several thousand percent, the exciting impedance to zero-sequence currents in a three-phase core-form unit will lie in the range from 30 to 300 percent, the higher values applying to the largest power transformers. Low exciting impedance under zero-sequence conditions is reflected in some reduction in the through impedances to zero-sequence current flow. A star-star grounded, three-phase, two-winding unit of the core-form, or a star-star grounded autotransformer of the three-phase core form acts, because of this characteristic, as if it had a tertiary winding of relatively high reactance. In small core-form units this characteristic is particularly effective and can be utilized to replace a tertiary winding for neutral stabilization and third harmonic excitation.

The zero-sequence exciting impedance is affected by the magnitude of excitation voltage, and it is also affected by tank construction. For example, the zero-sequence exciting impedance of a 4000-kva, 66 000-2400-volt unit was measured to be 84 percent at normal voltage before the core was placed in the tank; it was measured to be 36 percent at normal voltage after the core and coils were placed in the tank. In this case the tank saturated but acted as a short-circuited secondary winding around the transformer, tending to limit the area of the flux return path to that between tank and windings. The zero-sequence exciting impedance is measured by connecting the three windings in parallel and applying a single-phase voltage to the paralleled windings.

The zero-sequence exciting impedance of three-phase core-form units is generally much lower than the positive-sequence exciting impedance, and much lower than the zero-sequence exciting impedance of three-phase shell-form units or three single-phase units. For this reason it is necessary to consider the zero-sequence exciting impedance in deriving the zero-sequence impedance characteristics for certain connections involving core-form units. The exciting impedance to zero-sequence currents has been denoted by Z_{SE} , Z_{PE} , etc., where the first subscript refers to the winding on which the zero-sequence exciting impedance is measured in ohms. Following the same notation, $Z_{SE}\%$ is the exciting impedance of the S winding to zero-sequence currents expressed in percent on the kva of the S winding. The number of branches required to define an equivalent circuit of three-phase two- or multi-winding transformers is the same in general as has been de-

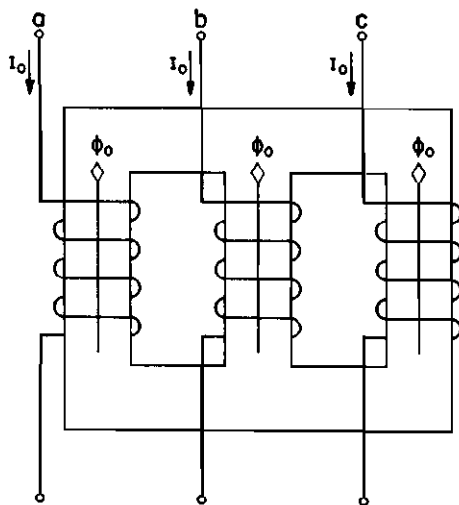

Fig. 55—Zero-sequence exciting currents and fluxes in a three-phase core-form transformer.

scribed for single phase transformers. A notable exception to this will exist in the formulation of the zero-sequence impedance of core form transformers with grounded neutral. In this case an extra impedance branch must be provided in the equivalent circuit, this branch being always short-circuited to the neutral bus, and having a value dependent upon the zero-sequence excitation impedances of the windings as well as the grounding impedance in the transformer neutral. If the three-phase bank connections are unsymmetrical as in the case of the open-delta connection, mutual coupling will exist between the sequence networks.

57. Derivation of Equivalent Circuits

In the derivation of equivalent circuits for three-phase transformers and banks made up of three single-phase transformers, it is convenient to represent each winding of the transformer by a leakage impedance and one winding of an ideal transformer. This method may be used in the development of circuits for two- and three-winding transformers.

Two magnetically-coupled windings of a single-phase transformer having n_1 and n_2 turns, respectively, are shown schematically in Fig. 56(a). The customary equivalent circuit used to represent such a single-phase transformer is shown in Fig. 56(b) in which Z_A and Z_B are components of the transformer leakage impedance, with a more or less arbitrary division of the leakage impedance between Z_A and Z_B . Z_M is the so-called "magnetizing shunt branch." Since the numerical value of Z_M is very large compared to Z_A and Z_B , for most calculations Fig. 56(b) is approximated by Fig. 56(c) where Z_M is considered infinite. Either of these circuits has serious deficiencies as a device representing the actual transformer; the voltage and current transformation effected by transformer action is not represented in the equivalent circuit, and the circuit terminals a and a' are not insulated from each other as in the actual transformer. These disadvantages are evidenced particularly when analyzing transformer circuits wherein several windings or phases are interconnected. To overcome these deficiencies it is expedient to use the equivalent circuit shown in Fig. 56(d) which combines the circuit of Fig. 56(b) with an ideal transformer. The ideal transformer is defined as having infinite exciting impedance (zero exciting current) and zero leakage impedance, and serves to transform voltage and current without impedance drop or power loss; the ideal transformer thus restores actual voltage and current relationships at the terminals a and a' . The circuit of Fig. 56(e) is obtained from Fig. 56(d) by converting the impedance Z_B to the E_a' voltage base (by multiplying Z_B by the square of the voltage ratio). This process may be thought of as "sliding the ideal transformer through" the impedance Z_B . If the exciting, or no load, current may be neglected (Z_M considered as infinite) the circuit of Fig. 56(e) becomes Fig. 56(f).

Finally, if Z_M is considered infinite, the circuit of Fig. 56(f) becomes Fig. 56(g), in which the two parts of the leakage impedance, Z_A and Z_B , combine into the complete leakage impedance Z_{PS} , where

$$Z_{PS} = Z_A + Z_B \tag{86}$$

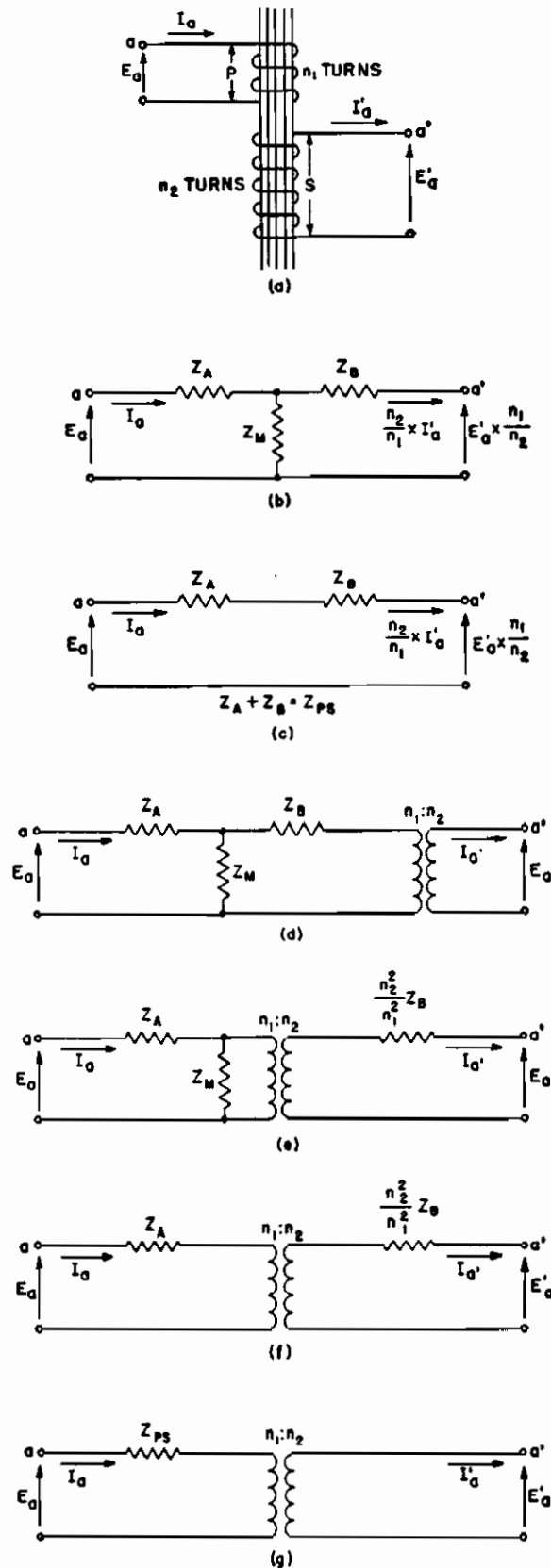

Fig. 56—Steps in the derivation of the equivalent circuit of a two-winding transformer.

In most developments the circuit of Fig. 56(g) will be found most convenient, although in some cases it becomes desirable to have part of the leakage impedance associated with each winding, and the circuit of Fig. 56(f) may be used.

To be perfectly definite, Z_{PS} is understood to mean the leakage impedance, as measured in ohms, with the S winding short circuited, and voltage applied to the P winding. When the test is reversed, with voltage applied to the S winding, and the P winding short circuited, the impedance is denoted by Z_{SP} . It is obvious from the development given that, when Z_M may be considered infinite,

$$Z_{SP} = \frac{n_2^2}{n_1^2} Z_{PS}. \quad (87)$$

58. Derivation of Equivalent Circuit for Star-Delta Bank

In Fig. 57 each transformer winding is represented by an impedance and one winding of an ideal transformer, the transformer having n_1 turns in the P winding and n_2 turns in the S winding. The windings shown in parallel are assumed to be on the same magnetic core. The voltages

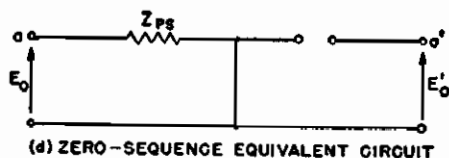
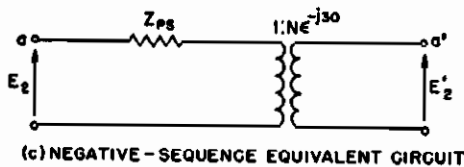
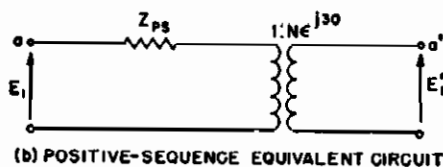
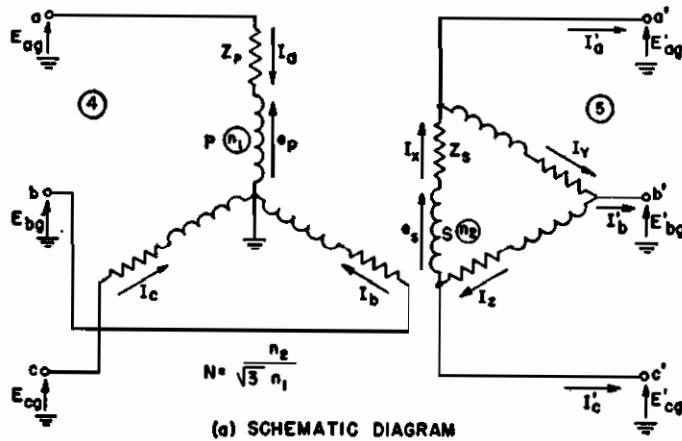

Fig. 57—Equivalent circuits of a star-delta transformer bank.

e_p and e_s represent the voltages across the P and S windings of the ideal transformers.

Assuming positive-sequence voltages E_{ag} , E_{bg} , and E_{cg} applied to the terminals abc , and a three-phase short-circuit at the $a'b'c'$ terminals, the following relations can be written:

$$\begin{aligned} E'_{ag} = E'_{bg} = E'_{cg} &= 0 & n_2 I_x &= n_1 I_a \\ e_s &= I_x Z_s & I_x &= \frac{n_1}{n_2} I_a \\ e_p &= \frac{n_1}{n_2} e_s = \frac{n_1}{n_2} I_x Z_s = \left(\frac{n_1}{n_2}\right)^2 I_a Z_s \\ E_{ag} = e_p + I_a Z_P &= I_a \left[Z_P + \left(\frac{n_1}{n_2}\right)^2 Z_s \right] \end{aligned} \quad (88)$$

Designating the circuits connected to the abc and $a'b'c'$ terminals as circuits 4 and 5, respectively,

$$Z_{45} = \frac{E_{ag}}{I_a} = Z_P + \left(\frac{n_1}{n_2}\right)^2 Z_s = Z_{PS} \quad (89)$$

Z_{45} is defined as the impedance between circuits 4 and 5 in ohms on the circuit 4 voltage base. Z_{PS} is the impedance between the P and S windings as measured by applying voltage to the P winding with the S winding short-circuited.

With positive-sequence voltages applied to the abc terminals and the $a'b'c'$ terminals open circuited,

$$\begin{aligned} E_{bg} &= a^2 E_{ag} & E'_{bg} &= a^2 E'_{ag} \\ E_{cg} &= a E_{ag} & E'_{cg} &= a E'_{ag} \\ e_s &= \frac{n_2}{n_1} e_p = E'_{ag} - E'_{cg} \\ E_{ag} = e_p &= \frac{n_1}{n_2} (E'_{ag} - a E'_{ag}) \\ &= \frac{n_1}{n_2} E'_{ag} (1 - a) = \sqrt{3} \frac{n_1}{n_2} E'_{ag} \epsilon^{-j30}. \end{aligned} \quad (90)$$

Letting $N = \frac{n_2}{\sqrt{3} n_1}$, $E'_{ag} = N E_{ag} \epsilon^{j30}$.

As positive-sequence quantities were used in this analysis, the final equation can be expressed as follows:

$$E'_1 = N E_1 \epsilon^{j30}, \quad (91)$$

where E'_1 and E_1 are the positive-sequence voltages to ground at the transformer terminals.

The above relations show that the line-to-ground voltages on the delta side lead the corresponding star-side voltages by 30 degrees, which must be considered in a complete positive-sequence equivalent circuit for the transformer. A consideration of Eqs. (88) will show that the currents I'_a , I'_b and I'_c also lead the currents I_a , I_b and I_c by 30 degrees.

$$\begin{aligned} I_x &= \frac{n_1}{n_2} I_a & I_y &= \frac{n_1}{n_2} I_b = \frac{n_1}{n_2} a^2 I_a \\ I'_a = I_x - I_y &= \frac{n_1}{n_2} (I_a - a^2 I_a) \\ &= \frac{I_a}{N} \epsilon^{j30}. \\ I'_1 &= \frac{I'_a}{N} \epsilon^{j30}. \end{aligned} \quad (92)$$

The complete positive-sequence circuit in Fig. 57(b) therefore includes the impedance Z_{PS} and an ideal transformer having a turns ratio N and a 30-degree phase shift.

A similar analysis, made with negative-sequence voltages and currents, would show that

$$I'_2 = \frac{I_2}{N} \epsilon^{-j30} \tag{93}$$

$$E'_2 = NE_2 \epsilon^{-j30} \tag{94}$$

The positive- and negative-sequence circuits are therefore identical excepting for the direction of the phase shifts introduced by the star-delta transformation.

The zero-sequence circuit is derived by applying a set of zero-sequence voltages to the abc terminals. In this case

$$E_{a0} = E_{b0} = E_{c0} = E_0$$

$$I_a = I_b = I_c = I_0$$

$$E_{a0} = e_p + Z_P I_a$$

$$e_s - I_x Z_S = 0 \text{ because no zero-sequence voltage can be present between line terminals.} \tag{95}$$

$$I_x = \frac{n_1}{n_2} I_a$$

$$e_p = \frac{n_1}{n_2} e_s = \left(\frac{n_1}{n_2}\right)^2 I_a Z_S$$

$$E_{a0} = I_a \left[\left(\frac{n_1}{n_2}\right)^2 Z_S + Z_P \right] = I_a Z_{PS}$$

$$Z_0 = \frac{E_0}{I_0} = \frac{E_{a0}}{I_a} = Z_{PS}, \text{ which is the same impedance as was obtained with positive-sequence voltages and currents.} \tag{96}$$

If zero-sequence voltages are applied to the $a'b'c'$ terminals, no current can flow because no return circuit is present. The zero-sequence impedance of the transformer bank is therefore infinite as viewed from the delta side.

59. Derivation of Equivalent Circuit for Autotransformer with Delta Tertiary

The basic impedances of an autotransformer with a delta tertiary may be defined in terms of the leakage impedances between pairs of windings, with the third winding open circuited. The impedance between the primary and secondary, or common and series, windings of the transformer in Fig. 58(a) may be obtained by applying a voltage across the P winding with the S winding short circuited, and the T winding open circuited. Referring to Fig. 59,

$$\begin{aligned} e_s &= \left(\frac{1}{n_1}\right) I Z_S & e_p &= \frac{e_s}{n_1} = \frac{I Z_S}{n_1^2} \\ E &= e_p + I Z_P \\ &= I \left(\frac{Z_S}{n_1^2} + Z_P \right) \\ Z_{PS} &= E/I = \frac{Z_S}{n_1^2} + Z_P. \end{aligned} \tag{97}$$

Similar relations can be derived for the impedances

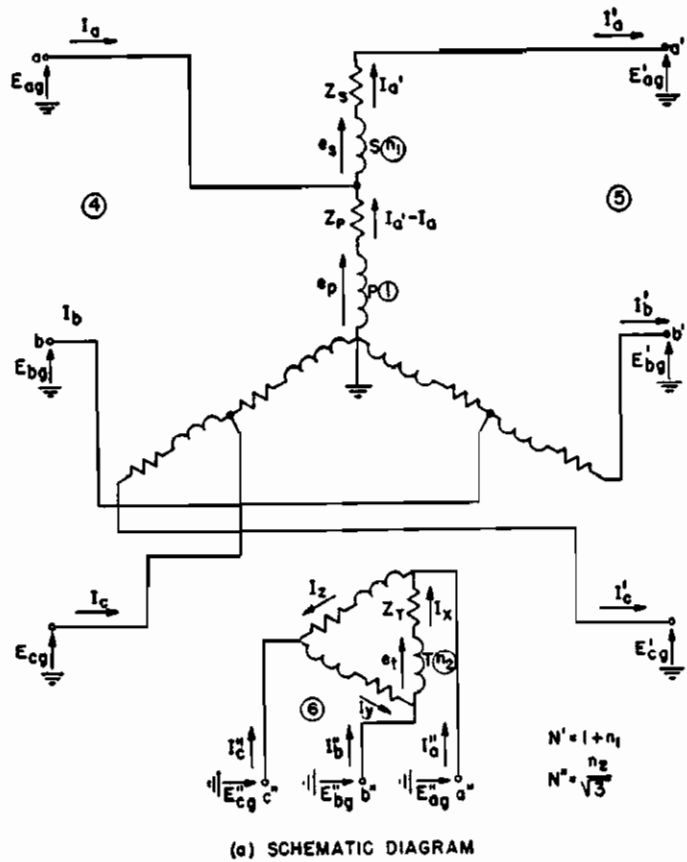

(a) SCHEMATIC DIAGRAM

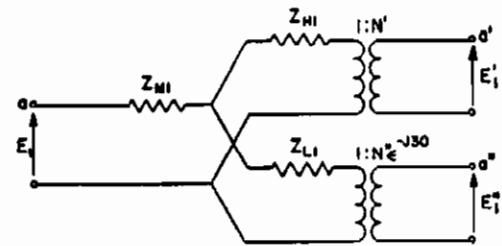

(b) POSITIVE-SEQUENCE EQUIVALENT CIRCUIT

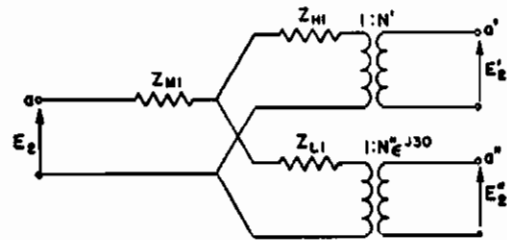

(c) NEGATIVE-SEQUENCE EQUIVALENT CIRCUIT

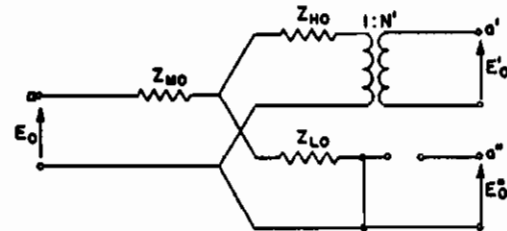

(d) ZERO-SEQUENCE EQUIVALENT CIRCUIT

Fig. 58—Equivalent circuits of a three-winding autotransformer.

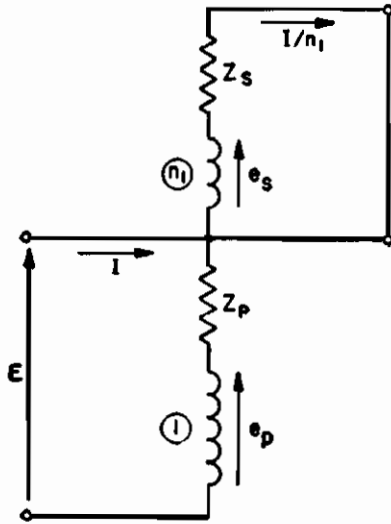

Fig. 59—Representation of the primary- to secondary-winding impedance of an autotransformer.

between the P and T , and S and T windings, resulting in the set of equations

$$\begin{aligned} Z_{PS} &= \frac{Z_S}{n_1^2} + Z_P \\ Z_{PT} &= \frac{Z_T}{n_2^2} + Z_P \\ Z_{ST} &= \left(\frac{n_1}{n_2}\right)^2 Z_T + Z_S. \end{aligned} \quad (98)$$

These equations can be solved for the individual winding impedances Z_P , Z_S and Z_T .

$$\begin{aligned} Z_P &= \frac{1}{2} \left[Z_{PS} + Z_{PT} - \frac{Z_{ST}}{n_1^2} \right] \\ Z_S &= \frac{1}{2} \left[Z_{ST} + n_1^2 Z_{PS} - n_1^2 Z_{PT} \right] \\ Z_T &= \frac{1}{2} \left[\left(\frac{n_2}{n_1}\right)^2 Z_{ST} + n_2^2 Z_{PT} - n_2^2 Z_{PS} \right] \end{aligned} \quad (99)$$

The impedances among circuits 4, 5 and 6 can be derived in terms of the impedances between windings, using the same procedure as employed in the derivation of the impedances of the star-delta bank in section 58.

With positive-sequence voltages applied to terminals abc , terminals $a'b'c'$ short circuited and terminals $a''b''c''$ open circuited, the following relations can be written:

$$\begin{aligned} E'_{ag} = E'_{bg} = E'_{cg} &= 0 & e_s &= n_1 e_p \\ I'_a - I_a + n_1 I'_a &= 0 & I'_a &= \frac{I_a}{1+n_1} \\ e_p + e_s - (I'_a - I_a)Z_P - I'_a Z_S &= 0. \end{aligned}$$

Eliminating e_s and I'_a from the above equation:

$$\begin{aligned} e_p(1+n_1) &= \frac{I_a}{1+n_1} (Z_P + Z_S) - I_a Z_P \\ e_p &= \frac{I_a}{(1+n_1)^2} (Z_P + Z_S) - \frac{I_a Z_P}{1+n_1} \end{aligned} \quad (100)$$

$$\begin{aligned} E_{ag} &= e_p - (I'_a - I_a)Z_P \\ &= e_p + I_a Z_P \left(1 - \frac{1}{1+n_1}\right) \\ &= I_a \times \frac{Z_S + n_1^2 Z_P}{(1+n_1)^2} \\ Z_{45} &= \frac{E_{ag}}{I_a} = \frac{n_1^2}{(1+n_1)^2} \left[Z_P + \frac{Z_S}{n_1^2} \right] \\ &= \frac{n_1^2}{(1+n_1)^2} \times Z_{PS}. \end{aligned} \quad (101)$$

Representing the circuit transformation ratio $(1+n_1)$ by N' ,

$$Z_{45} = \left(\frac{N'-1}{N'}\right)^2 \times Z_{PS} \quad (102)$$

The impedance between circuits 4 and 6 may be obtained by applying positive-sequence voltages to terminals abc , with terminals $a'b'c'$ open and $a''b''c''$ shorted circuited. In this case:

$$\begin{aligned} e_t &= I_x Z_T & I_x &= I_a/n_2 \\ e_p &= \frac{e_t}{n_2} = \frac{I_a Z_T}{n_2^2} \\ E_{ag} &= e_p + I_a Z_P \\ &= I_a \left[\frac{Z_T}{n_2^2} + Z_P \right] \\ Z_{46} &= \frac{E_{ag}}{I_a} = \frac{Z_T}{n_2^2} + Z_P = Z_{PT}. \end{aligned} \quad (103)$$

With positive-sequence voltages applied to terminals $a'b'c'$, terminals abc open and terminals $a''b''c''$ short circuited,

$$\begin{aligned} e_t &= I_x Z_T & I_x &= -\frac{1+n_1}{n_2} I'_a \\ e_p + e_s &= \frac{1+n_1}{n_2} e_t = -\left(\frac{1+n_1}{n_2}\right)^2 I'_a Z_T \\ E'_{ag} &= e_p + e_s - I'_a (Z_P + Z_S) \\ &= -I'_a \left[\left(\frac{1+n_1}{n_2}\right)^2 Z_T + Z_P + Z_S \right] \\ Z_{56} &= \left(\frac{1+n_1}{n_2}\right)^2 Z_T + Z_P + Z_S. \end{aligned} \quad (104)$$

Expressing Z_P , Z_S and Z_T in terms of impedances between windings as given in Eq. (99):

$$Z_{56} = (1+n_1)Z_{PT} + \left(\frac{1+n_1}{n_1}\right)Z_{ST} - n_1 Z_{PS}. \quad (105)$$

The above equation is the impedance between circuits 5 and 6 in ohms on the circuit 5 voltage base. As Z_{45} and Z_{46} are ohmic impedances on the circuit 4 base, it is convenient to express the circuit 5 to circuit 6 impedance on the same base. Dividing by $(1+n_1)^2$,

$$\begin{aligned} \frac{Z_{56}}{(1+n_1)^2} &= \frac{Z_{PT}}{1+n_1} + \frac{Z_{ST}}{n_1(1+n_1)} - \frac{n_1}{(1+n_1)^2} Z_{PS} \\ \frac{Z_{56}}{(N')^2} &= \frac{1}{N'} \times Z_{PT} + \frac{Z_{ST}}{N'(N'-1)} - \frac{N'-1}{N'^2} \times Z_{PS} \end{aligned} \quad (106)$$

The transformer can be represented by the positive-sequence equivalent circuit in Fig. 58(b). The relations between the impedances in the equivalent circuit and the impedances between circuits can be expressed as follows:

$$\begin{aligned} Z_{M1} + Z_{H1} &= Z_{45} \\ Z_{M1} + Z_{L1} &= Z_{46} \\ Z_{H1} + Z_{L1} &= \frac{Z_{56}}{(N')^2} \end{aligned} \quad (107)$$

$$\begin{aligned} Z_{H1} &= \frac{1}{2} \left[Z_{45} + \frac{Z_{56}}{(N')^2} - Z_{46} \right] \\ Z_{M1} &= \frac{1}{2} \left[Z_{45} + Z_{L1} - \frac{Z_{56}}{(N')^2} \right] \\ Z_{L1} &= \frac{1}{2} \left[Z_{46} + \frac{Z_{56}}{(N')^2} - Z_{45} \right] \end{aligned} \quad (108)$$

$$\begin{aligned} Z_{H1} &= \frac{N'-1}{2N'} \left[\frac{N'-2}{N'} Z_{PS} + \frac{Z_{ST}}{(N'-1)^2} - Z_{PT} \right] \\ Z_{M1} &= \frac{N'-1}{2N'} \left[Z_{PS} + Z_{PT} - \frac{Z_{ST}}{(N'-1)^2} \right] \\ Z_{L1} &= \frac{N'-1}{2N'} \left[\frac{N'+1}{N'-1} Z_{PT} + \frac{Z_{ST}}{(N'-1)^2} - Z_{PS} \right] \end{aligned} \quad (109)$$

$$\begin{aligned} Z_{45} &= \left(\frac{N'-1}{N'} \right)^2 Z_{PS} \\ Z_{46} &= Z_{PT} \\ Z_{56} &= N' Z_{PT} + \frac{N'}{N'-1} Z_{ST} - (N'-1) Z_{PS} \end{aligned} \quad (110)$$

$$\begin{aligned} Z_{PS} &= \left(\frac{N'}{N'-1} \right)^2 Z_{45} \\ Z_{PT} &= Z_{46} \\ Z_{ST} &= (N'-1) \left[\frac{Z_{56}}{N'} + \frac{N'}{N'-1} Z_{46} - Z_{45} \right] \end{aligned} \quad (111)$$

In the above equations Z_{H1} , Z_{M1} , Z_{L1} , Z_{45} and Z_{46} are in ohms on the circuit 4 (abc terminals) voltage base. Z_{56} is in ohms on the circuit 5 ($a'b'c'$ terminals) voltage base. Z_{PS} and Z_{PT} are in ohms on the P winding voltage base and Z_{ST} is in ohms on the S winding voltage base. N' is defined as $1+n_1$, which is the ratio of line-to-line or line-to-neutral voltages between circuit 5 ($a'b'c'$ terminals) and circuit 4 (abc terminals).

The phase shifts between circuit voltages can be determined by applying positive-sequence voltages to terminals abc with the other two circuits open circuited. Under these conditions,

$$\begin{aligned} E_{ag} &= e_p & E'_{ag} &= e_p + e_s \\ E'_{ag} &= (1+n_1) E_{ag} = N' E_{ag}, \text{ which shows that the one} \\ & & & \text{ideal transformer has an } N' \text{ ratio but no phase} \\ & & & \text{shift.} \\ e_t &= E_{ag}'' - E_{bg}'' = E_{ag}'' (1-\alpha^2) \\ e_t &= n_2 e_p = n_2 E_{ag} \\ E_{ag}'' &= \frac{n_2}{1-\alpha^2} E_{ag} = \frac{n_2}{\sqrt{3}} E_{ag} \epsilon^{-j30} \end{aligned} \quad (112)$$

Defining $\frac{n_2}{\sqrt{3}}$ as N'' ,

$$E_{ag}'' = N'' E_{ag} \epsilon^{-j30}.$$

The second ideal transformer therefore has an N'' turns ratio and a 30 degree phase shift.

Negative-Sequence Circuit—A similar analysis made with negative-sequence voltages would show that the impedances in the equivalent circuit are the same as in the positive-sequence circuit, and that the terminal voltages are related as follows:

$$\begin{aligned} E_2' &= N' E_2 \\ E_2'' &= N'' E_2 \epsilon^{+j30}. \end{aligned} \quad (113)$$

The positive- and negative-sequence circuits are therefore identical excepting for the direction of the phase shift introduced by the star-delta transformation.

Zero-sequence circuit—The zero-sequence characteristics of the transformer can be obtained as follows:

1. Apply zero-sequence voltages to terminals abc with terminals $a'b'c'$ connected to ground and the delta opened. This permits evaluation of the zero-sequence impedance between circuit 4 and circuit 5.

2. Apply zero-sequence voltages to terminals abc with the delta closed and terminals $a'b'c'$ open circuited.

3. Apply zero-sequence voltages to terminals $a'b'c'$ with the delta closed and terminals abc open circuited.

The general procedure in writing the necessary equations is similar to that followed in the positive-sequence analysis given above, and the zero-sequence analysis in section 57. It will be found that the zero-sequence impedances in the equivalent circuit shown in Fig. 58(d) are the same as the positive-sequence quantities, that is,

$$\begin{aligned} Z_{H0} &= Z_{H1} \\ Z_{M0} &= Z_{M1} \\ Z_{L0} &= Z_{L1} \end{aligned} \quad (114)$$

If the neutral of the autotransformer is ungrounded, the zero-sequence equivalent circuit is altered considerably as shown in Fig. 60. In this case zero-sequence current flows

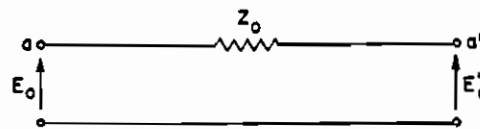

Fig. 60—Zero-sequence equivalent circuit of an ungrounded three-winding autotransformer.

between terminals abc and $a'b'c'$ without transformation. Current in the S winding is balanced by circulating currents in the tertiary, with no current flow in the P winding. The zero-sequence impedance is therefore determined by the leakage impedance between the S and T windings. Applying zero sequence voltages to the abc terminals, with the $a'b'c'$ terminals connected to ground and the tertiary closed,

$$I_s = I_s' = -\frac{n_2}{n_1} I_x$$

$$e_t = I_x Z_T$$

$$e_s = \frac{n_1}{n_2} e_t = -\left(\frac{n_1}{n_2} \right)^2 I_s' Z_T$$

$$\begin{aligned}
 E_{as} &= I'_a Z_s - e_s \\
 &= I'_a \left[Z_s + \left(\frac{n_1}{n_2} \right)^2 Z_T \right] \\
 Z_0 &= \frac{E_{as}}{I'_a} = \frac{E_{as}}{I'_a} = Z_s + \left(\frac{n_1}{n_2} \right)^2 Z_T = Z_{ST} \\
 &= (N' - 1) \left[\frac{Z_{56}}{N'} + \frac{N'}{N' - 1} Z_{45} - Z_{46} \right] \quad (115)
 \end{aligned}$$

Percent Quantities—The manufacturer normally expresses transformer impedances in percent on a kva base corresponding to the rated kva of the circuits involved. These percent values can be converted to ohms by the familiar relation

$$Z = \frac{10Z\%E^2}{\text{kva}}, \text{ where} \quad (116)$$

Z = impedance in ohms.

$Z\%$ = impedance in percent.

kva = 3-phase kva rating of circuit.

E = line-to-line circuit voltage in kv.

Using the nomenclature employed in the derivations,

$$Z_{45} = \frac{10Z_{45}\% E_4^2}{U_4}, \text{ where}$$

E_4 = line-to-line voltage, in kv, of circuit 4.

U_4 = three-phase kva rating of circuit 4.

$Z_{45}\%$ = impedance between circuits 4 and 5 in per cent on kva rating of circuit 4.

Z_{45} = impedance between circuits 4 and 5 in ohms on the circuit 4 voltage base.

Similar relations can be written for the other impedances involved.

It should be noted that the impedances, as used in this chapter and in the Appendix, are expressed in terms of the voltage or kva rating of the circuit or winding denoted by the first subscript. For example Z_{45} is in ohms on the circuit 4 voltage base, whereas Z_{54} would be in ohms on the circuit 5 voltage base. These impedances can be converted from one circuit base to another as follows:

$$\begin{aligned}
 Z_{64} &= \left(\frac{E_5}{E_4} \right)^2 Z_{45} \\
 Z_{54}\% &= \frac{U_5}{U_4} Z_{45}\% \quad (117)
 \end{aligned}$$

The equivalent circuits can be based directly on percent quantities as shown in Table 7 of the Appendix. Con-

sidering the autotransformer with delta tertiary (case D-1 in Table 7), the equivalent circuit impedances can be obtained from the impedances between circuits as follows:

$$\begin{aligned}
 Z_{H1}\% &= \frac{1}{2} \left[\frac{U_4}{U_6} Z_{56}\% + Z_{45}\% - Z_{46}\% \right] \\
 Z_{M1}\% &= \frac{1}{2} \left[Z_{45}\% + Z_{46}\% - \frac{U_4}{U_5} Z_{56}\% \right] \\
 Z_{L1}\% &= \frac{1}{2} \left[Z_{46}\% + \frac{U_4}{U_5} Z_{56}\% - Z_{45}\% \right] \quad (118)
 \end{aligned}$$

The resulting impedances will all be in percent on the circuit 4 kva base.

REFERENCES

1. Electric Circuits—Theory and Applications, by O. G. C. Dahl (a book) Vol. 1, p. 34, McGraw-Hill Book Company, Inc., New York.
2. Regulating Transformers in Power-System Analysis, by J. E. Hobson and W. A. Lewis, *A.I.E.E. Transactions*, Vol. 58, 1939, p. 874.
3. Fundamental Concepts of Synchronous Machine Reactances, by B. R. Prentice, *A.I.E.E. Transactions*, Vol. 56, 1937, pp. 1–22 of Supplement.
4. Simplified Computation of Voltage Regulation with Four Winding Transformers, by R. D. Evans, *Electrical Engineering*, October 1939, p. 420.
5. Surge Proof Transformers, by H. V. Putman, *A.I.E.E. Transactions*, September 1932, pp. 579–584 and discussion, pp. 584–600.
6. American Standards for Transformers, Regulators, and Reactors. American Standards Association, ASA C57, 1948.
7. Loading Transformers by Copper Temperature, by H. V. Putman and W. M. Dann *A.I.E.E. Transactions*, Vol. 58, 1939, pp. 504–509.
8. Equivalent Circuit Impedance of Regulating Transformers, by J. E. Clem, *A.I.E.E. Transactions*, Vol. 58, 1939, pp. 871–873.
9. Theory of Abnormal Line to Neutral Transformer Voltages, by C. W. LaPierre, *A.I.E.E. Transactions*, Vol. 50, March 1931, pp. 328–342.
10. Standards for Transformers NEMA Publication No. 48–132, September 1948.
11. An Equivalent Circuit for the Four-Winding Transformer, by F. M. Starr, *General Electric Review*, March 1933, Vol. 36, pp. 150–152.
12. Transformer Engineering, by L. F. Blume, et al, (a book), John Wiley and Sons (1938).
13. Equivalent Circuits for Power and Regulating Transformers, by J. E. Hobson and W. A. Lewis, *Electric Journal Preprint*, January 1939.
14. J. and P. Transformer Book, by Stigant, 6th Edition, 1935, Johnson and Phillips, London.

MACHINE CHARACTERISTICS

Original Author:

C. F. Wagner

Revised by:

C. F. Wagner

BEFORE the growth of the public utilities into their present enormous proportions with large generating stations and connecting tie lines, machine performance was largely judged in terms of the steady-state characteristics. The emergence of the stability problem gave rise to the analysis of the transient characteristics of machines and was largely responsible for our present knowledge of machine theory. A further contributing urge was the need for more accurate determination of short-circuit currents for the application of relays and circuit breakers.

The variable character of the air gap of the conventional salient-pole synchronous generator, motor, and condenser with its concentrated field windings requires that their analysis follow a different line from that for machines such as induction motors, which have a uniform air gap and distributed windings. Blondel originally attacked this problem by resolving the armature mmf's and fluxes into two components, one in line with the axis of the poles and the other in quadrature thereto. When the study of the transients associated with system stability was undertaken

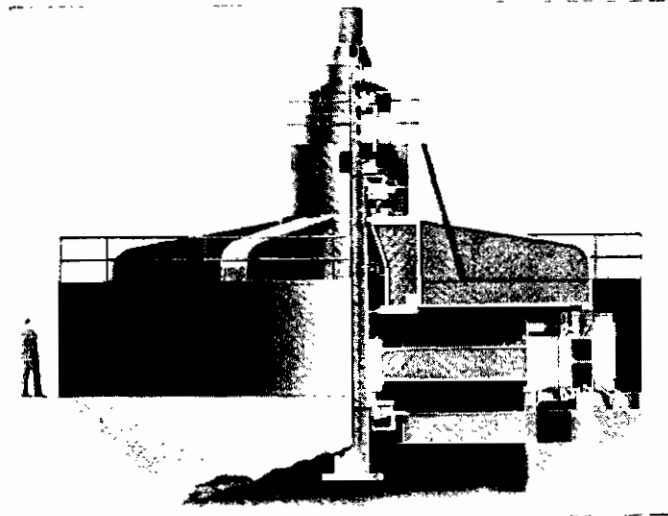

Fig. 2—Cut-away view of conventional waterwheel generator.

this conception was quickly recognized as an invaluable tool^{1,2}. Since that time the method has been extended by subsequent investigators,³⁻⁹ notably Doherty and Nickle, who introduced into the industry several new constants, such as transient reactance and subtransient reactance to describe machine performance under transient conditions.

This chapter treats of the characteristics of synchronous and induction machines in the light of the development of the past twenty-five years. It will consider steady-state and transient conditions for both salient pole and cylindrical rotor machines under both balanced and unbalanced conditions. There follows a discussion of the characteristics of induction motors under such transient conditions as might contribute to the short-circuit current of a system and might influence the choice of a circuit breaker.

I. STEADY-STATE CHARACTERISTICS OF SYNCHRONOUS MACHINES

The two general types of synchronous machines are the cylindrical rotor machine or turbine generator which has an essentially uniform air gap and the salient-pole generator. Figs. 1 to 5 illustrate the outward appearances and cross-sectional views of typical modern machines.

Typical saturation curves for a hydrogen-cooled turbine generator, a waterwheel-generator and a synchronous condenser are shown in Figs. 6, 7, and 8 respectively.

Because of the necessity of matching the speed of waterwheel-generators to the requirements of the waterwheels it is difficult to standardize units of this type. However,

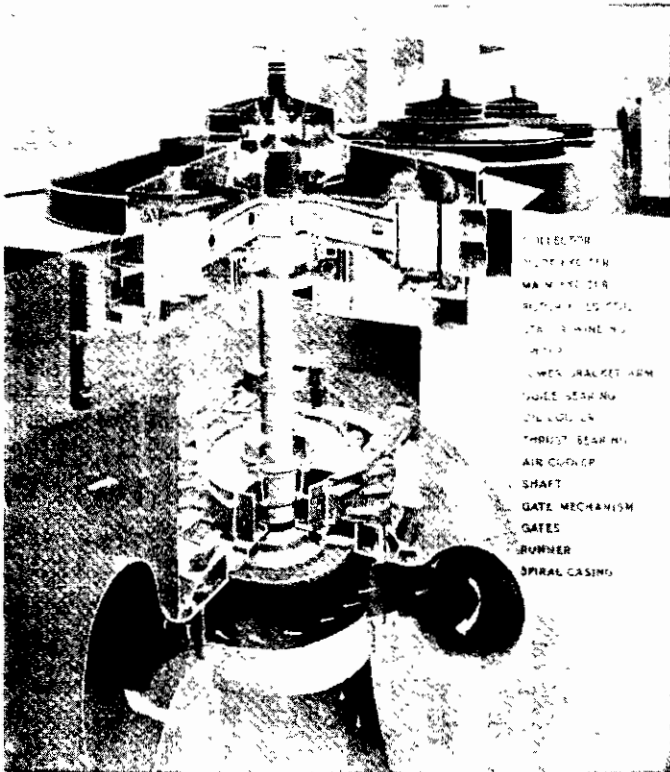

Fig. 1—Cut-away view of umbrella-type waterwheel generator.

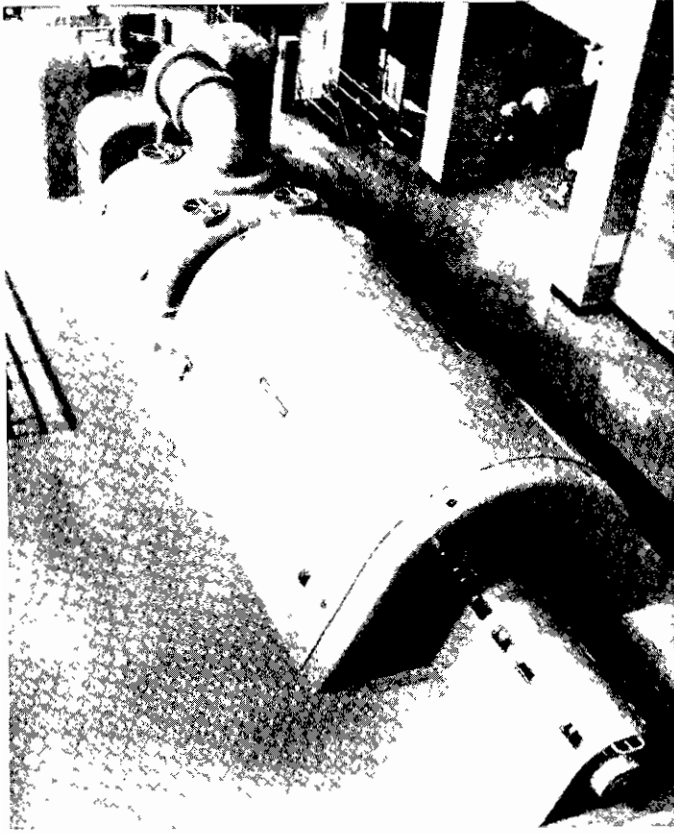

Fig. 3—Steam turbine generator installed at the Acme Station of the Toledo Edison Company, 90 000 kw, 85-percent power factor, 85-percent *SCR.*, 13 800 volt, 3-phase, 60-cycle.

great strides have been made with large 3600-rpm condensing steam turbine-generators. These find their greatest application in the electric utility industry. Table 1 of Chap. 1 gives some of the specifications²⁰ for these machines.

The concept of per-unit quantity is valuable in comparing the characteristics of machines of different capacities and voltages. However, care must be exercised in the case of generators to use the same reference value for field cur-

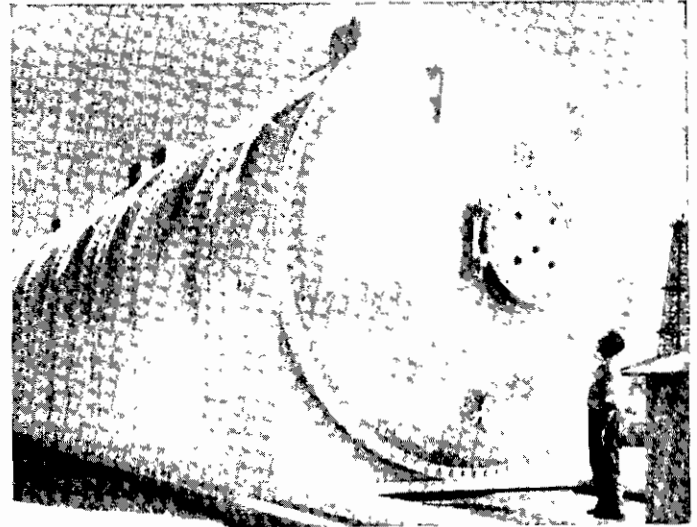

Fig. 5—Hydrogen-cooled frequency changer set installed on the system of the City of Los Angeles, 60 000 kva; 600 rpm; 50 cycle—11 500 volts; 60 cycles—13 200 volts.

rent. Depending upon the application, either the field current for rated voltage in the air gap or the actual field current for rated voltage, including saturation, is used.

1. Unsaturated Cylindrical-Rotor Machine Under Steady-State Conditions

The vector diagram of Fig. 9 is the well-known diagram of a cylindrical-rotor machine. Consistent with the policy of this book, familiarity with this diagram is assumed. Let it suffice merely to indicate the significance of the quantities. The vectors e_t and i represent the terminal voltage to neutral and armature current, respectively. Upon adding the armature resistance drop, ri , and armature leakage reactance drop, $x_l i$ to e_t , the vector e_1 is obtained, which represents the voltage developed by the air-gap flux Φ , which leads e_1 by 90 degrees. This flux represents the net flux in the air gap. To produce this flux a field current, I_f , is required. The current I_f can be taken from the no-load

Fig. 4—Cut-away view of hydrogen-cooled turbine generator.

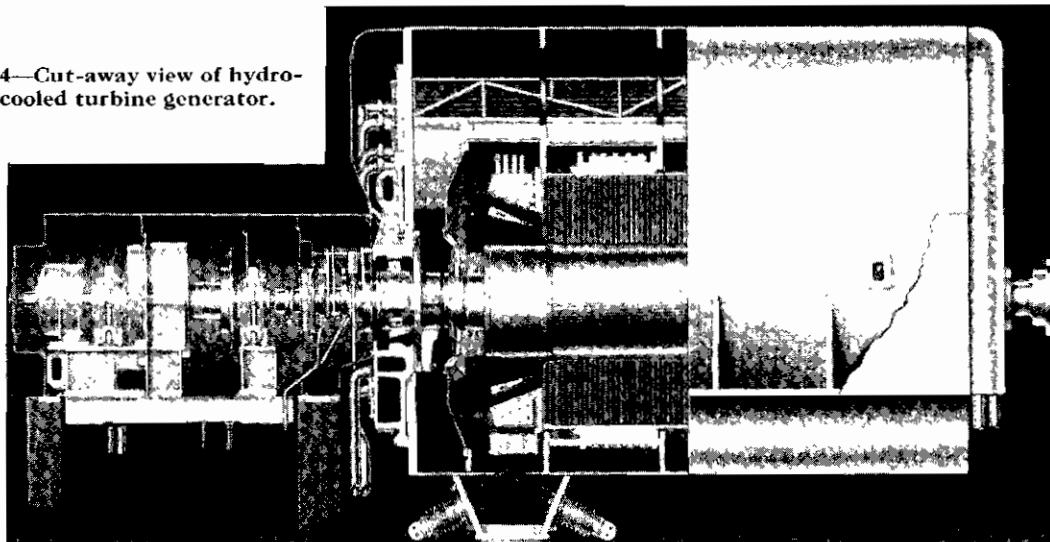

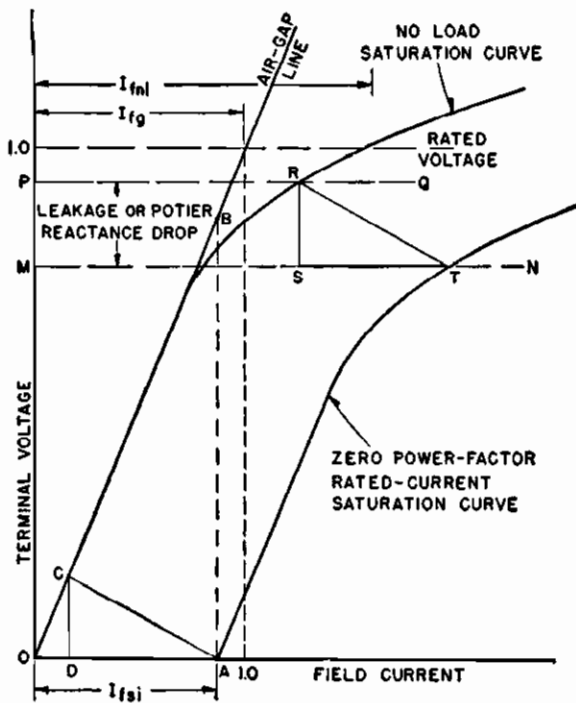

Fig. 10—No-load and full-load zero power-factor characteristics of a generator.

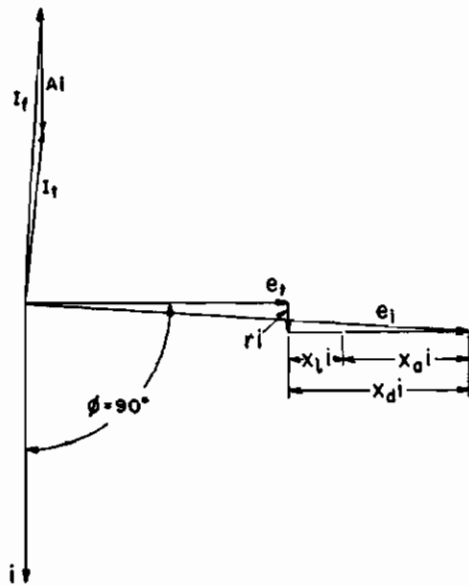

Fig. 11—Vector diagram of cylindrical-rotor generator at zero power-factor.

can be accepted as true for all practical purposes. However, as the real load is applied to the machine the angle δ increases from zero and the lead of OC ahead of e_t increases from 90 degrees to 90 degrees plus δ . The angle δ is a real angle; it can be measured without much difficulty.

It is convenient for some purposes to resolve the reactions within the machine into two components, one along the axis of the field winding and the other in quadrature thereto. In Fig. 9, the armature current is divided into the two components, i_d , and, i_q , in which the subscripts are significant of their respective components. When this is

done, it can be seen that $x_a i$ can likewise be thought of as arising from the two components of i in the form of $x_{ad} i_d$ and $x_{aq} i_q$, respectively, in leading quadrature to i_d and i_q . In the case of a cylindrical rotor machine, x_{ad} and x_{aq} are both equal to x_a but a case will soon be developed for which they are not equal.

The synchronous reactance, x_d , can be obtained most conveniently from the no-load curve and the full-load zero power-factor curve. In Fig. 10 OA is the field current required to circulate full-load current under short-circuit conditions, the terminal voltage being zero. In this case all of the internal voltage (the ri drop can be neglected justifiably) must be consumed as synchronous reactance drop ($x_d i$) within the machine. If there were no saturation, the internal voltage can be determined by simply reading the terminal voltage when the short-circuit is removed, maintaining the field current constant meanwhile. This voltage would in Fig. 10 be equal to AB . Thus the unsaturated synchronous reactance per phase is equal to the phase-to-neutral voltage AB divided by the rated current. When the saturation curve is expressed in per unit or percent it is equal to AB ; but where expressed in generator-terminal voltage and field amperes, it is equal to $\frac{I_{tsi}}{I_{tg}}$ (100)

in percent or $\frac{I_{tsi}}{I_{tg}}$ in per unit.

2. Unsaturated Salient-Pole Machine Under Steady-State Conditions

Given the proper constants, the performance of an unsaturated salient-pole machine at zero power-factor is the same as for a uniform air-gap machine. For other power-factors, conditions are different. A vector diagram for such machines is shown in Fig. 12. As before e_t and i are the

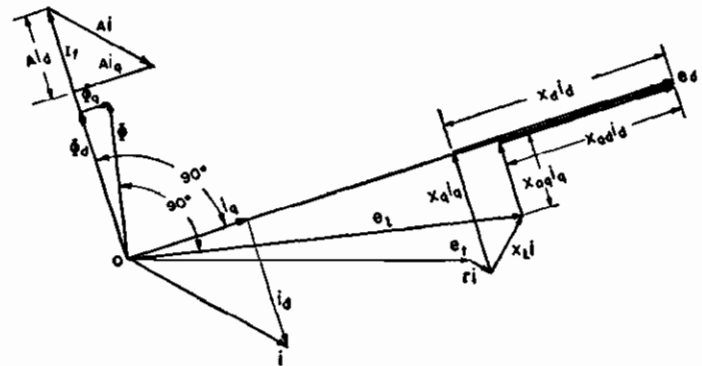

Fig. 12—Vector diagram of salient-pole machine.

terminal voltage to neutral and the armature current, respectively, and e_l is the "voltage behind the leakage reactance drop." The flux Φ is required to produce e_l . This flux can be resolved into two components Φ_d and Φ_q . The flux Φ_d is produced by I_f and Ai_d , the direct-axis component of Ai , and Φ_q is produced by Ai_q , the quadrature-axis component of Ai . Here the similarity ceases. Because of the saliency effect, the proportionality between the mmf's and their resultant fluxes is not the same in the two axes. When saturation effects are neglected Φ_d can be regarded as made up of a component produced by I_f acting

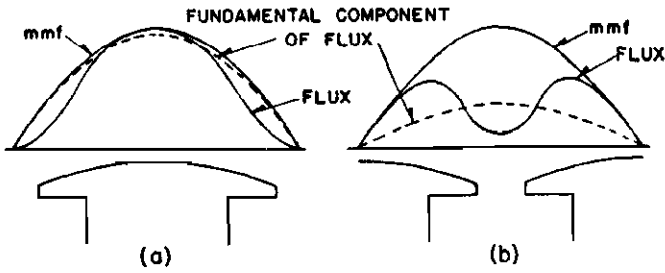

Fig. 13—Flux resulting from a sinusoidal mmf in (a) direct axis, (b) quadrature axis.

alone and a component produced by I_f . The component produced by I_f can be regarded as producing the internal voltage e_d . The mmf produced by I_f has a general sinusoidal distribution in the direct axis as shown by Fig. 13(a). The resultant flux because of the variable reluctance of the air gap has the general shape indicated. It is the sinusoidal component of this flux that is effective in producing the $x_{ad} i_d$ drop shown in Fig. 12. In the quadrature axis, the component of mmf is likewise sinusoidal in nature as shown in Fig. 13b, and gives rise to the distorted flux form. In proportion to the mmf the sinusoidal component of flux is much less than for the direct axis. The effect of this component is reflected in the $x_{aq} i_q$ drop of Fig. 12. In general x_{aq} is much smaller than x_{ad} .

The armature resistance and leakage reactance drops can also be resolved into its two components in the two axes much as $x_a i$ of Fig. 9 was resolved. When this is done the internal voltage e_d can be obtained by merely adding $r i_d$ and $r i_q$ and then $j x_q i_q$ and $j x_d i_d$ to the terminal voltage e_t . The notation e_d is used to differentiate the internal voltage in this development from that used with the cylindrical rotor machine theory.

Another form of the vector diagram of the machine is presented in Fig. 14, which shows much better the relation between those quantities that are most useful for calculation purposes. If from B the line BP of length $x_q i$ is drawn perpendicular to i , then since angle CBP is equal to $\phi + \delta$, the distance BC is equal to $x_q i \cos(\phi + \delta)$, or $x_q i_q$. By comparing this line with the corresponding line in Fig. 12, it can be seen that the point P determines the angle δ . This relation provides an easy construction for the determination of the angle δ having given the terminal voltage, the armature current, and the power-factor angle, ϕ . Further,

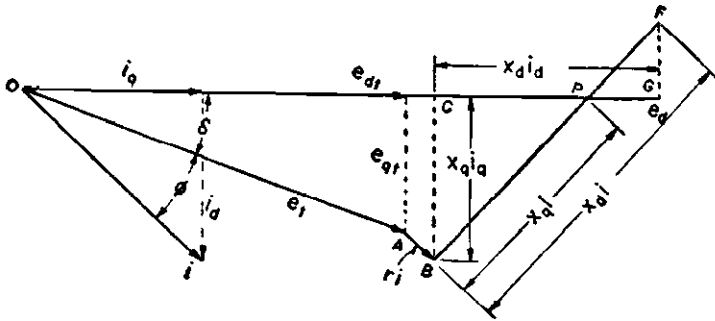

Fig. 14—Determination of internal angle, δ , and excitation of an unsaturated salient-pole machine when loading is known.

the projection of BF upon OG is equal to $x_d i_d$ so that OG becomes equal to e_d , the fictitious internal voltage, which is proportional to I_f .

The armature resistance is usually negligible in determining either the angle δ or the excitation and for this case

$$e_t \sin \delta = x_q i_q = x_q i \cos(\phi + \delta) \tag{2}$$

Upon expanding the last term and solving for δ

$$\tan \delta = \frac{x_q i \cos \phi}{e_t + x_q i \sin \phi} \tag{3}$$

From Fig. 14, the internal voltage

$$e_d = e_t \cos \delta + x_d i \sin(\phi + \delta) \tag{4}$$

The unsaturated synchronous reactance, x_d , can be determined from the no-load and full-load zero power-factor curves just as for the machine with uniform air gap. The quadrature-axis synchronous reactance is not obtained so

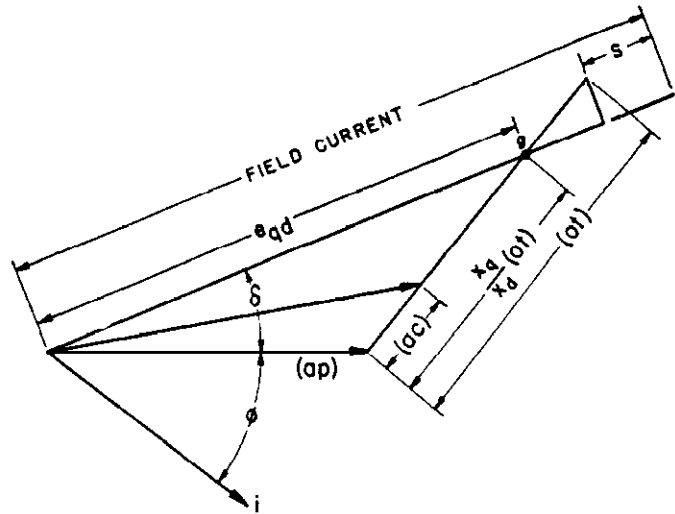

FOR SIGNIFICANCE OF QUANTITIES IN PARENTHESES REFER TO FIG. 14

Fig. 15—Determination of internal angle, δ , and excitation of a saturated salient pole machine when loading is known.

easily but fortunately there is not as much need for this quantity. It can be determined from a test involving the determination of the angular displacement of the rotor as real load is applied to the machine and the use of Eq. (2), which gives

$$x_q = \frac{e_t \sin \delta}{i \cos(\phi + \delta)} \tag{5}$$

or it can be determined by means of a slip test. The slip test is described in the A.I.E.E. Test Code for Synchronous Machines¹⁰ of 1945 for a determination of x_d . The test for the determination of x_q is identical except that the minimum ratio of armature voltage to armature current is used.

3. Saturation in Steady-State Conditions

Short-circuit ratio is a term used to give a measure of the relative strengths of the field and armature ampere turns. It is defined as the ratio of the field current required to produce rated armature voltage at no load to the field current required to circulate rated armature current with the armature short-circuited. In Fig. 10 the SCR is equal

The distance jk represents the synchronous reactance drop, $x_d i$. If there were no saturation the synchronous internal voltage would be Ok . When using per unit quantities throughout this is also equivalent to the field current. This method includes the effect of saturation by simply adding s , the increment in field current for this voltage in excess of that required for no saturation, to Ok in phase with e_p , giving as a result, Oh . When per unit quantities are not used the construction is a little more complicated. It involves the construction of e_p separately so that s can be obtained in terms of field current. This quantity is then added to the diagram for no saturation in terms of the field current. In Fig. 18, first lay off from the terminal voltage, Oa , and then the x_p drop ac at an angle with the horizontal equal to the power-factor angle. Oc then represents e_p . By scribing this back to the ordinate and reading horizontally, the excitation corresponding to this voltage is obtained. The effect of saturation is introduced by the distance s . The field current required if there were no saturation is obtained by the construction Oj and jk where Oj represents the excitation, ap , required to produce the terminal voltage at no load and jk the excitation, ot , for the synchronous reactance drop, read from the abscissa. These vectors correspond to e_s and jk , respectively, in Fig. 19 except that they are in terms of field current. If kh , equal to the saturation factor, s , is added along a line parallel to Oc , the total excitation Oh is obtained.

(c) Round Rotor Potier Voltage Method*—This method is the same as (b) except that the effect of saturation s , in Fig. 18 is, for the sake of simplicity laid off along Ok , making om the desired excitation. As can be seen, there is little difference between those two methods. This method gives the best overall results, especially at leading power factors. The particular name of this method was assigned to distinguish it from the next method.

(d) Two-Reaction Potier Voltage Method—This method is similar to that of (c), except that the two-reaction method of construction shown in Fig. 14 is used to determine the excitation before including the saturation factor s . Fig. 15 shows the entire construction. For the sake of comparison with other methods, the construction is also shown in Fig. 18. The construction is the same as (c) except that the line Oq is made to pass through the point g instead of k . This arises because x_q is smaller than x_d .

4. Reactive Power Capacity

The capacity of a synchronous machine to deliver reactive power is dependent upon the real power that it delivers. Two limitations from the heating standpoint are recognized: (1) that due to the armature, and (2) that due to the field. Figure 20 shows the reactive power capability of a standardized 3600-rpm steam turbine-generator. Real power is plotted as abscissa and reactive power as ordinate. All the curves are arcs of circles. The line centering about the origin represents the limit imposed by the condition of constant armature current whereas the other arc by constant field current. With regard to the latter, the generator can be likened to a simple transmission line of pure reactance, x_d , with the receiver voltage held at a constant value, e_t , the terminal voltage of the generator, and with the

*Described as Method (a) Para. 1.520 in Reference 10.

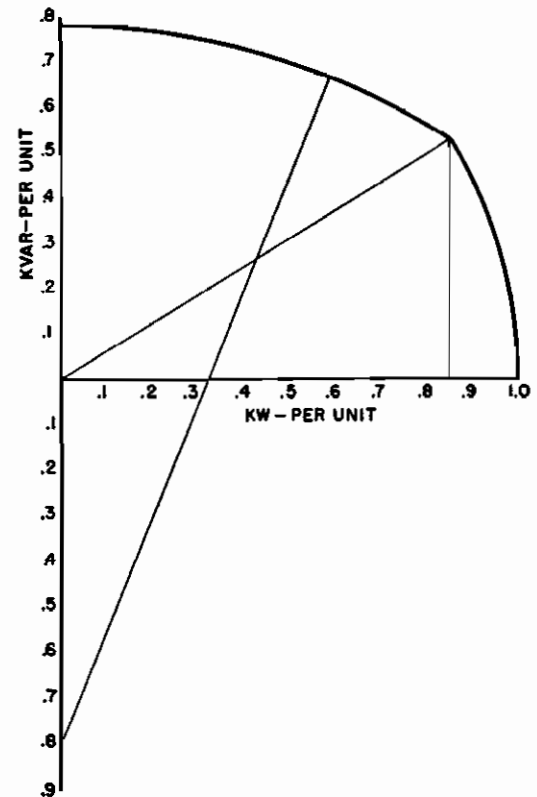

Fig. 20—Reactive power capacity of steam turbine generator 20 000 kw, 23 529 kva, 0.85 p.f., 0.8 SCR, at 0.5 psig hydrogen.

sending voltage held at a constant value e_d . As shown in Chaps. 9 and 10 the power circle of a line of such characteristics has its center in the negative reactive axis at $\frac{e_t^2}{x_d}$ and

its internal voltage, e_d , must be such that its radius, $\frac{e_d e_t}{x_d}$, passes through the point of rated real power and rated reactive power. Actually, however, the center is usually located at a point equal to (SCR) times (rated kva). This is to take care of saturation effects. Since, however, with no saturation $\frac{1}{x_d}$ is equal to SCR , it can be seen that for this condition both relations reduce to an equivalence.

The leading kvar capacity (underexcited) of air-cooled condensers is usually about 50 percent of the lagging kvar capacity but for hydrogen-cooled condensers about 42 percent.

II. THREE-PHASE SHORT CIRCUIT

In addition to its steady-state performance, the action of a machine under short-circuit conditions is important. The presence of paths for flow of eddy currents as provided by the solid core in turbine generators and by the damper windings in some salient-pole machines makes the treatment of these machines, from a practical viewpoint, less complicated than that for salient-pole machines without damper windings. For this reason the three-phase short-circuit of these types of machines will be discussed first. Armature resistance will be neglected except as it influences decrement factors.

5. Three-phase Short-Circuit of Machines with Current Paths in Field Structures

Consideration will be given to a simultaneous short-circuit on all phases while the machine is operating at no-load normal voltage without a voltage regulator.

The general nature of the currents that appear is shown in Fig. 21. They can be divided into two parts:

a. An alternating component in the armature and associated with it an unidirectional component in the field. These two components decay or decrease together with the

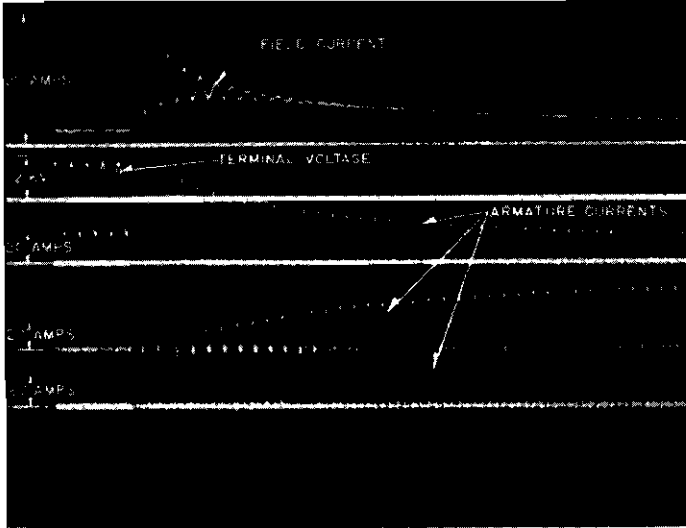

Fig. 21—Three-phase short circuit in salient-pole machine with damper windings.

same time constants. The alternating armature component can be regarded as being produced by its associated unidirectional component in the field. All phase components of the alternating current are essentially the same except that they are displaced 120 electrical degrees.*

b. An unidirectional component in the armature and an alternating component in the field or in the damper windings. In this case, likewise, the alternating current in the field winding can be regarded as produced by the unidirectional component in the armature.

6. Alternating Component of Armature Current

This component can in turn be resolved into several components, the r.m.s. values of which are shown in Fig. 22. They are:

- The steady-state component
- The transient component
- The subtransient component

Each of these components will be discussed separately.

Steady-State Components—The steady-state component, as its name implies, is the current finally attained. Because of the demagnetizing effect of the large short-circuit current, the flux density within the machine decreases below a point where saturation is present. Satur-

*The machine used in this case was a salient-pole machine. As will be seen later, such machines also contain a second harmonic component of current. This type of machine was chosen to show more clearly the presence of field and damper currents.

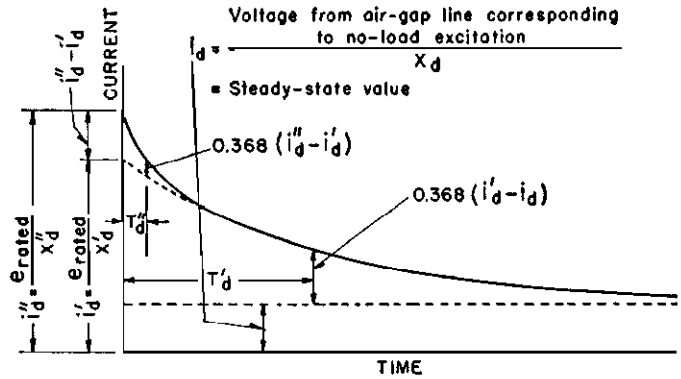

Fig. 22—Symmetrical component of armature short-circuit current (three-phase short circuit from no-load rated voltage). Values are rms.

tion is important only as it affects the field current necessary to produce normal voltage at no load. The steady-state value of short-circuit current is thus equal to the line-to-neutral voltage read from the air-gap line for the value of field current required to produce normal voltage divided by the synchronous reactance in ohms.

Transient Component—If the excess of the symmetrical component of armature currents over the steady-state component be plotted on semi-log paper, it can be seen that this excess, except for the first few cycles, is an exponential function of time (the points lie in a straight line). Extending this straight line back to zero time and adding the steady-state component, the so-called *transient component*, i_d' , or armature current is obtained. This component is defined through a new reactance, called the *transient reactance* by means of the expression

$$i_d' = \frac{e_{\text{rated}}}{x_d'}$$

The manner in which this quantity is related to the exponential and steady-state terms is shown in Fig. 22.

In discussing this component, the presence of the damper-winding currents of salient-pole machines and rotor eddy currents of turbine generators can, for the moment, be neglected. Before short-circuit occurs the flux associated with the field windings can be broken up into two components (see Fig. 23), a component Φ that crosses the air gap and a component Φ_1 , a leakage flux that can be regarded as linking all of the field winding. Actually, of course, the leakage flux varies from the base of the pole to the pole tip. The flux Φ_1 is so weighted that it produces the same linkage with all the field turns as the actual leakage flux produces with the actual turns. It is approximately proportional to the instantaneous value of the field current I_f . The total flux linkages with the field winding are then those produced by the flux $(\Phi + \Phi_1)$. As the field structure rotates, a balanced alternating voltage and current of normal frequency are produced in the armature. Because the armature resistance is relatively small, its circuit can be regarded as having a power-factor of zero. The symmetrical current thus produced develops an mmf that rotates synchronously and has a purely demagnetizing, as contrasted with cross magnetizing, effect on the field fluxes.

It is a well-known fact that for the flux linkages with a

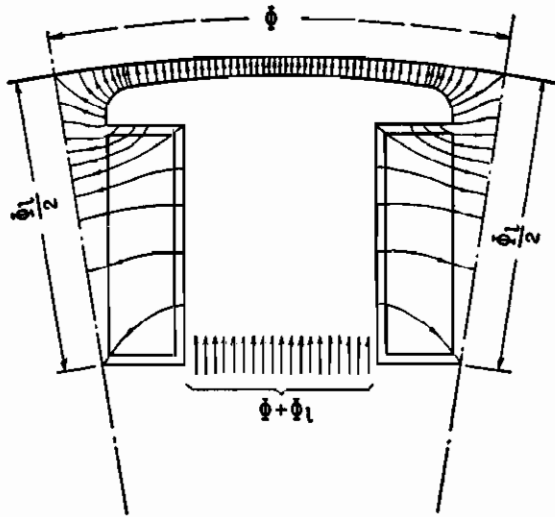

Fig. 23—Air-gap and leakage fluxes at no load.

circuit to change instantly, an infinitely large voltage is necessary and the assumption is justified that, for the transition period from the no load open-circuited condition to the short-circuited condition, the flux linkages with the field winding can be regarded as constant. This is equivalent to saying that the flux $(\Phi + \Phi_l)$ remains constant. In order that this flux remain constant in the presence of the demagnetizing effect of the armature current, it is necessary that the field current I_f increase to overcome the demagnetizing effect of the armature current. If I_f increases then Φ_l , which is proportional to it, must likewise increase. It follows then that Φ must decrease. Consideration of the steady-state conditions has shown that the air-gap voltage, e_1 , is proportional to the air-gap flux Φ . The armature current for short-circuit conditions is equal to $\frac{e_1}{x_1}$. If Φ and consequently e_1 had remained constant during the transition period, then the transient component of short-circuit current would be merely the no-load voltage before the short-circuit divided by the leakage reactance and the transient reactance would be equal to the armature leakage reactance x_1 . However, as just shown, the air-gap flux decreases and, therefore, the armature current is less. It follows then that the transient reactance must be greater than the armature leakage reactance. It is a reactance that includes the effect of the increased field leakage occasioned by the increase in field current.

Under steady-state conditions with no saturation, the armature current can be viewed as produced by a fictitious internal voltage equal to $x_d i_d$ whose magnitude is picked from the air-gap line of the no-load saturation curve for the particular field current. At the first instant of short-circuit, the increased armature current, i_d' , can likewise be viewed as being produced by a fictitious internal voltage behind synchronous reactance, whose magnitude is $x_d i_d'$ or $x_d \frac{e_{rated}}{x_d}$, if the short-circuit be from rated voltage, no load.

This voltage provides a means for determining the initial value of the unidirectional component of field current by picking off the value of I_f on the air-gap line of the no-load saturation curve corresponding to this voltage. If it were

possible to increase the exciter voltage instantaneously to an amount that would produce this steady-state field current, then this component of short-circuit current would remain sustained. It is important to grasp the significance of this truth. There is always a constant proportionality between the alternating current in the armature and the unidirectional (often called direct-current) component of current in the field winding, whether the operating condition be steady-state or transitory.

The initial value of armature current, as stated, gradually decreases to the steady-state and the induced current in the field winding likewise decreases to its steady-state magnitude. The increments of both follow an exponential curve having the same time constant. Attention will next be given to considerations affecting this time constant.

If a constant direct voltage is suddenly applied to the field of a machine with the armature open-circuited, the current builds up exponentially just as for any circuit having resistance and inductance in series. The mathematical expression of this relation is:

$$I_f = \frac{e_x}{r_f} \left[1 - e^{-\frac{t}{T'_{do}}} \right] \quad (6)$$

in which

e_x is the exciter voltage.

r_f is the resistance of the field winding in ohms.

T'_{do} is the open-circuit transient time constant of the machine or of the circuit in question in seconds.

t is time in seconds.

The time constant is equal to the inductance of the field winding divided by its resistance. In the case of the short-circuited machine, it was shown that at the first instant the flux linkages with the field winding remain the same as for the open-circuit condition, but that the direct component of field current increases to $\frac{x_d}{x_d'}$ times the open-circuit value before short-circuit. Since inductance is defined as the flux linkages per unit current, it follows then that the inductance of the field circuit under short-circuit must equal $\frac{x_d'}{x_d}$ times that for the open-circuit condition. The short-circuit transient time constant, that is, the time constant that determines the rate of decay of the transient component of current must then equal

$$T_d' = \frac{x_d'}{x_d} T'_{do} \text{ in seconds}$$

The component of armature current that decays with this time constant can then be expressed by

$$(i_d' - i_d) e^{-\frac{t}{T_d'}}$$

When t is equal to T_d' the magnitude of the component has decreased to e^{-1} or 0.368 times its initial value. This instant is indicated in Fig. 22.

Subtransient Component—In the presence of damper windings or other paths for eddy currents as in turbine generators, the air-gap flux at the first instant of short-circuit is prevented from changing to any great extent. This results both from their close proximity to the air gap

and from the fact that their leakage is much smaller than that of the field winding. Consequently, the initial short-circuit currents of such machines are greater. If this excess of the symmetrical component of armature currents over the transient component is plotted on semi-log paper, the straight line thus formed can be projected back to zero time. This zero-time value when added to the transient component gives the subtransient current, i_d'' . This *subtransient current* is defined by the *subtransient reactance* in the expression

$$i_d'' = \frac{e_{\text{rated}}}{x_d''}$$

The subtransient reactance approaches the armature leakage differing from that quantity only by the leakage of the damper windings.

Since the excess of the armature currents represented by the subtransient components over the transient components are sustained only by the damper winding currents, it would be expected that their decrement would be determined by that of the damper winding. Since the copper section of this winding is so much smaller than that of the field winding, it is found that the short-circuit subtransient time constant, T_d'' , is very small, being about 0.05 second instead of the order of seconds as is characteristic of the transient component. The component of armature current that decays with this time constant is $(i_d'' - i_d')$ and can be expressed as a function of time as

$$(i_d'' - i_d') e^{-\frac{t}{T_d''}}$$

Thus the time in seconds for this component to decrease to 0.368 times its initial value gives T_d'' as indicated in Fig. 22.

Tests on machines without damper windings show that because of saturation effects, the short-circuit current even in this case can be resolved into a slow transient component and a much faster subtransient component. The influence of current magnitudes as reflected by saturation upon the transient and subtransient reactance is discussed in more detail under the general heading of Saturation.

7. Total Alternating Component of Armature Current

The total armature current consists of the steady-state value and the two components that decay with time constants T_d' and T_d'' . It can be expressed by the following equation

$$i_{ao} = (i_d'' - i_d') e^{-\frac{t}{T_d''}} + (i_d' - i_d) e^{-\frac{t}{T_d'}} + i_d \quad (7)$$

The quantities are all expressed as rms values and are equal but displaced 120 electrical degrees in the three phases.

8. Unidirectional Component of Armature Current

To this point consideration has been given to flux linkages with the field winding only. The requirement that these linkages remain constant at transition periods determined the alternating component of armature current. Since these components in the three phases have a phase displacement of 120 degrees with respect to each other,

only one can equal zero at a time. Therefore at times of three-phase short-circuits, the alternating component of current in at least two and probably all three phases must change from zero to some finite value. Since the armature circuits are inductive, it follows that their currents cannot change instantly from zero to a finite value. The "theorem of constant flux linkages" must apply to each phase separately. The application of this theorem thus gives rise to an unidirectional component of current in each phase equal and of negative value to the instantaneous values of the alternating component at the instant of short circuit. In this manner the armature currents are made continuous as shown in Fig. 24. Each of the unidirectional components

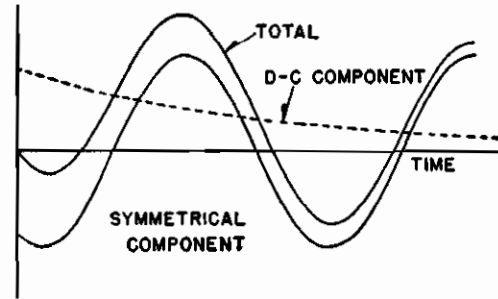

Fig. 24—The inclusion of a d-c component of armature current whose existence is necessary to make the armature current continuous at the instant of short circuit.

in the three phases decays exponentially with a time constant T_a , called the armature short-circuit time constant. The magnitude of this time constant is dependent upon the ratio of the inductance to resistance in the armature circuit. As will be shown the negative-sequence reactance, x_2 , of the machine is a sort of average reactance of the armature with the field winding short-circuited, so that it is the reactance to use in determining T_a . There exists then the relation

$$T_a = \frac{x_2}{2\pi f r_a} \text{ in seconds} \quad (8)$$

in which r_a is the d-c resistance of the armature. The quantity $2\pi f$ merely converts the reactance to an inductance.

The maximum magnitude which the unidirectional

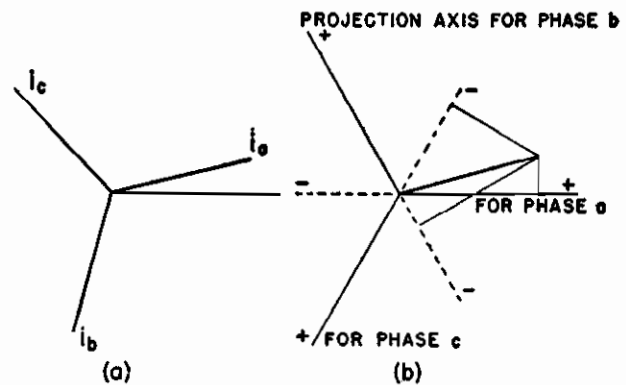

Fig. 25—Representation of instantaneous currents of a three phase system. (a) Three separate vectors projected on x-axis, (b) Single vector projected on three axes.

component can attain is equal to the maximum of the alternating component. Therefore,

$$i_{dc(max)} = \sqrt{2} \frac{e_{rated}}{x_d''} \quad (9)$$

A symmetrical three-phase set of currents can be represented as the projection of three equal-spaced and equal length vectors upon a stationary reference, say the real axis. They can also be represented as the projection, as it rotates, of one vector upon three stationary axes, spaced 120 degrees. These axes can conveniently be taken as shown in Fig. 25, as the horizontal-axis and two axes having a 120-degree relation therewith. Since the initial magnitude of the unidirectional components are the negatives of the instantaneous values of the alternating components at zero time, then the unidirectional components can be represented as the projection of a single vector onto the three equal-spaced axes. This fact is used at times to determine the maximum magnitude which the unidirectional component can attain. By its use it is unnecessary to await a test in which the maximum happens to occur. This method is in error, however, for machines in which x_q'' and x_d'' are radically different.

9. Total RMS Armature Current

The rms armature current at any instant is

$$\sqrt{i_{dc}^2 + i_{ac}^2}$$

The minimum current thus occurs in the phase in which the unidirectional component is zero and the maximum occurs when the unidirectional component is a maximum, that is, when maximum dissymmetry occurs. Since the maximum value that the unidirectional component can

attain is $\sqrt{2} \frac{e_{rated}}{x_d''}$, then

$$i_{rms(max)} = \sqrt{\left[\frac{\sqrt{2} e_{rated}}{x_d''} \right]^2 + \left[\frac{e_{rated}}{x_d''} \right]^2} = \sqrt{3} \frac{e_{rated}}{x_d''} \quad (10)$$

Of course, a rms value as its name implies, is an average quantity and is usually taken over a cycle or half cycle of time. The foregoing expression assumes that both the alternating and the unidirectional components do not decrease, because of the natural decrement, during the first cycle. In reality the decrement is usually sufficient to make the effect noticeable. In applying circuit breakers it is usual to use a factor 1.6 instead of $\sqrt{3}$. This factor includes a small decrement.

10. Effect of External Impedance

If the short-circuit occurs through an external impedance $r_{ext} + j x_{ext}$, and r_{ext} is not too large, their effect can be introduced by merely increasing the armature constants by these amounts. Thus the components of short-circuit current become

$$i_d'' = \frac{e_{rated}}{x_d'' + x_{ext}} \quad (11)$$

$$i_d' = \frac{e_{rated}}{x_d' + x_{ext}} \quad (12)$$

$$i_d = \frac{e_{airgap \text{ at no load}}}{x_d + x_{ext}} \quad (13)$$

The short-circuit time constant is affected in a similar manner

$$T_d' = \frac{x_d' + x_{ext}}{x_d + x_{ext}} T_{d0}' \text{ in seconds} \quad (14)$$

For the armature time constant, the external reactance must be added to the negative-sequence reactance of the machine and the external resistance to the armature resistance of the machine. The expression then becomes

$$T_a = \frac{x_2 + x_{ext}}{2\pi f(r_a + r_{ext})} \text{ in seconds} \quad (15)$$

Because of the much lower ratio of reactance to resistance in external portions of circuits, such as transformers or transmission lines, in the vast majority of cases T_a for faults out in the system is so small as to justify neglecting the unidirectional component of current.

11. Short Circuit from Loaded Conditions

The more usual case met in practice is that of a short-circuit on machines operating under loaded conditions. As before, the short-circuit current in the armature can be divided into two components, a symmetrical alternating component, and a unidirectional component.

Alternating Component—The alternating component in turn can be resolved into three components: (1) steady state, (2) transient, and (3) subtransient. Each of these components will be discussed individually.

The load on the machine affects the *steady-state component* only as it influences the field current before the short circuit. The field current can be determined by any of the methods discussed under the heading of "Steady-State Conditions." Saturation will be more important than for the no-load condition. The steady-state short-circuit current is then equal to the line-to-neutral voltage read from the air-gap line for the field current obtained for the loaded condition divided by x_d .

In the discussion of the determination of the *transient component* from the no-load condition, it was stated that the quantity that remained constant during the transition period from one circuit condition to another, is the flux linkages with the field winding. For the short-circuit from loaded conditions this same quantity can be used as a basis for analysis. Consideration will be given first to a load before short circuit whose power factor is zero, lagging, and whose current is i_{dL} . The flux linkages before short circuit will be determined by a superposition method, obtaining first the linkages with the field winding for zero armature current and any terminal voltage and then the flux linkages with armature current, i_{dL} , and zero terminal voltage. The total flux linkages is the sum of the two values so obtained.

Let ψ_1 be the flux linkages with the field winding at no-load at rated voltage. For any other terminal voltage such as e_t , the flux linkages ψ will be equal to

$$\frac{e_t}{e_{rated}} \psi_1 \quad (16)$$

By definition the transient reactance of a machine is equal to the reactance which, divided into the line-to-neutral rated voltage, gives the transient component of

short-circuit current at no-load normal voltage. If this short-circuit current is designated as $i_{d'1}$, then

$$i_{d'1} = \frac{e_{rated}}{x_d'} \quad (17)$$

At the instant of short-circuit from no-load at rated voltage, the flux linkages with the field winding, ψ_1 , remain constant. The demagnetizing effect of the armature current is overcome by an increase in the field current. Thus the armature current $i_{d'1}$ with its associated field current which is always proportional to it, can be regarded as producing the flux linkages ψ_1 with the field winding. For any other armature current, i_d' , assuming always that the armature is short-circuited, the flux linkages with the field winding are equal to $\frac{i_d'}{i_{d'1}} \psi_1$. Combined with Eq. (17),

$i_{d'1}$ can be eliminated giving $\psi = i_d' \frac{x_d' \psi_1}{e_{rated}}$. While this expression was derived from considerations applying only to the instant of transition, its application is more general. The only necessary considerations that must be satisfied are that the armature be short-circuited and that the field current contain a component of current to overcome the demagnetizing effect of the armature current. But these conditions are always satisfied even under steady-state conditions of short circuit, so, in general, it is permissible to replace i_d' in this expression by i_{dL} . The flux linkages with the field winding for the steady-state short-circuit condition thus become $i_{dL} \frac{x_d' \psi_1}{e_{rated}}$.

By application of the superposition theorem, the total flux linkages with the field winding can then be regarded as the sum of the flux linkages produced by the terminal voltage, namely $\frac{e_t}{e_{rated}} \psi_1$ and those by the armature current with zero terminal voltage, namely $i_{dL} \frac{x_d' \psi_1}{e_{rated}}$. If the armature current lags the voltage by 90 degrees, then the linkages are directly additive, and there results for the flux linkages with the field

$$\begin{aligned} \psi &= \frac{e_t}{e_{rated}} \psi_1 + i_{dL} \frac{x_d' \psi_1}{e_{rated}} \\ &= (e_t + x_d' i_{dL}) \frac{\psi_1}{e_{rated}} \end{aligned} \quad (18)$$

Since the flux linkages with the field winding produced by a unit of current i_d under short-circuit conditions is equal to $\frac{x_d' \psi_1}{e_{rated}}$ then the transient component of short-

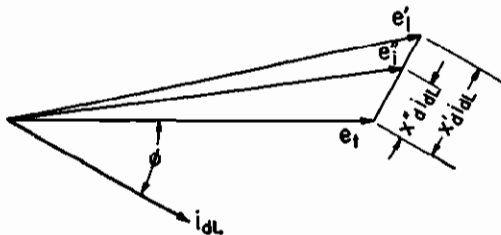

Fig. 26—Construction for the determination of internal voltages e_1' and e_1'' .

circuit current i' can be determined by dividing these linkages into the total flux linkages just determined. This gives

$$i' = \frac{\psi}{\frac{x_d' \psi_1}{e_{rated}}} = \frac{e_t + x_d' i_{dL}}{x_d'} \quad (19)$$

The numerator of this quantity can be regarded as an internal voltage, e_d' , which is equal to the terminal voltage plus a transient reactance drop produced by the load current.

When the power factor of the loads considered is other than zero lagging, the vector sense of current and terminal voltage must be introduced. This can be accomplished by computing e_d' for the operating condition in the same man-

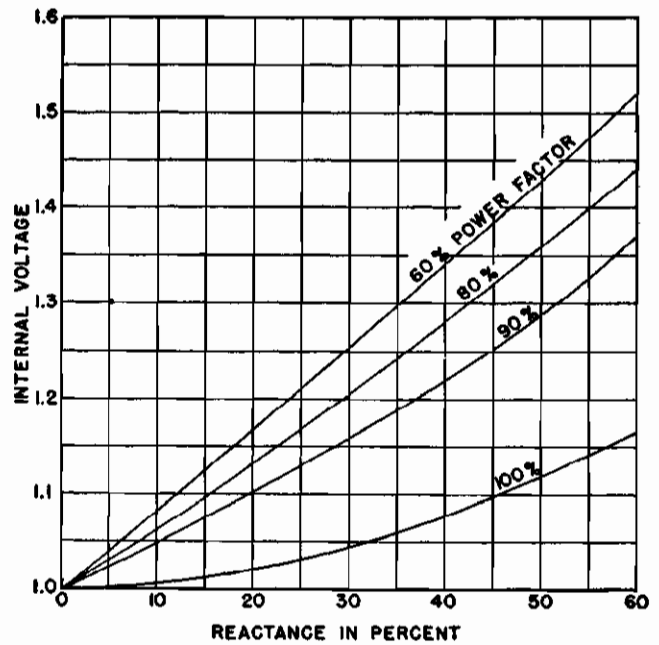

Fig. 27—Machine internal voltage as a function of reactance. Full-load rated voltage.

ner that e_d was determined in Fig. 14, except that x_d should be replaced by x_d' . The voltage e_d' should then replace $e_t + x_d' i_{dL}$ in (19). However, for nearly all practical purposes it is sufficiently accurate to replace e_d' by the amplitude of a quantity e_1' , which is usually referred to as the voltage behind transient reactance to distinguish it from similar internal voltages for which leakage, synchronous or subtransient reactance is used. The construction for this quantity is shown in Fig. 26 and to assist in the ready evaluation of the amplitude the curves in Fig. 27 are provided. The transient component of short-circuit current is then

$$i' = \frac{e_1'}{x_d'} \quad (20)$$

The subtransient component of short-circuit current is obtained in a manner similar to the transient component except that the subtransient reactance is used in the calculation of the internal voltage e_1'' . For loads of zero-power-factor lagging the subtransient reactance drop, $x_d'' i_{dL}$,

caused by the armature current is directly additive to the terminal voltage and for zero-power-factor leading directly subtractive. For other power-factors e_i'' can be obtained from Fig. 27 by using x_d'' . The subtransient component of short-circuit current is then

$$i'' = \frac{e_i''}{x_d''} \quad (21)$$

Unidirectional Component—In the three-phase short-circuit from no load, the unidirectional component of current was introduced to prevent a non-continuous transition of the instantaneous value of current from the no-load to the short-circuit condition. The unidirectional current performs a similar role for the short-circuit from loaded condition. Before the short-circuit the armature current is equal to i_{dL} and has some position with reference to e_t such as shown in Fig. 28. The subtransient com-

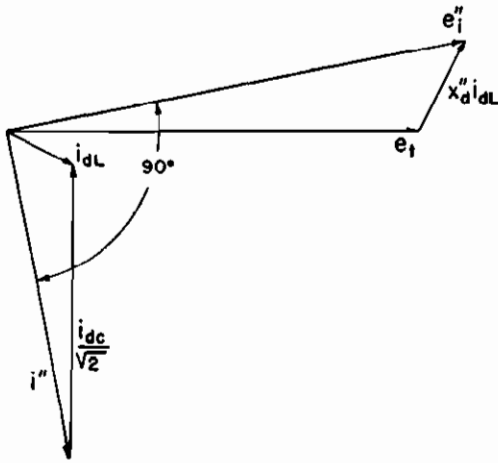

Fig. 28—Showing that i_{dc} for a short circuit from load is equal to the negative of $\sqrt{2}$ times the difference between i'' and i .

ponent, i'' , lags e_i'' by ninety degrees so i'' and i_{dL} will be determined with respect to each other. The $\sqrt{2}$ times the vector difference between these two quantities (since they are rms magnitudes) gives the unidirectional component necessary to produce smooth transition. The magnitude of this quantity varies between this amplitude and zero depending upon the point in the cycle at which short-circuit occurs.

Other Considerations—Time constants are not influenced by the nature of loading preceding the short-circuit. Total rms currents can be determined by the relations already given.

12. Three-Phase Short Circuit of Salient-Pole Machine without Damper Windings

For most applications it is sufficiently accurate to treat the salient-pole machine without damper windings just as other machines. It must be recognized, however, that this is only an approximate solution. Among other complications, in reality a strong second harmonic is present in the armature current. Doherty and Nickle⁶ have developed expressions for the armature currents for a three-phase short circuit from no load. These are given below.

$$i_a = \frac{x_d - x_d'}{x_d x_d'} e_t \epsilon^{-\frac{t}{T_d'}} \cos(2\pi ft + \alpha) + \frac{e_t}{x_d} \cos(2\pi ft + \alpha) - \frac{x_q - x_d'}{2x_d' x_q} e_t \epsilon^{-\frac{t}{T_a}} \cos(4\pi ft + \alpha) - \frac{x_q + x_d'}{2x_d' x_q} e_t \epsilon^{-\frac{t}{T_a}} \cos \alpha \quad (22)$$

$$i_b = \frac{x_d - x_d'}{x_d x_d'} e_t \epsilon^{-\frac{t}{T_d'}} \cos(2\pi ft + \alpha - 120^\circ) + \frac{e_t}{x_d} \cos(2\pi ft + \alpha - 120^\circ) - \frac{x_q - x_d'}{2x_d' x_q} e_t \epsilon^{-\frac{t}{T_a}} \cos(4\pi ft + \alpha - 120^\circ) - \frac{x_q + x_d'}{2x_d' x_q} e_t \epsilon^{-\frac{t}{T_a}} \cos(\alpha + 120^\circ) \quad (23)$$

$$i_c = \frac{x_d - x_d'}{x_d x_d'} e_t \epsilon^{-\frac{t}{T_d'}} \cos(2\pi ft + \alpha + 120^\circ) + \frac{e_t}{x_d} \cos(2\pi ft + \alpha + 120^\circ) - \frac{x_q - x_d'}{2x_d' x_q} e_t \epsilon^{-\frac{t}{T_a}} \cos(4\pi ft + \alpha + 120^\circ) - \frac{x_q + x_d'}{2x_d' x_q} e_t \epsilon^{-\frac{t}{T_a}} \cos(\alpha - 120^\circ). \quad (24)$$

Where

e_t = Terminal voltage before short-circuit.

$$T_d' = \frac{r^2 + x_d' x_q T_{do}}{r^2 + x_d x_q} \quad (25)$$

$$T_a = \frac{2x_d' x_q}{r(x_d' + x_q)} \quad (26)$$

α = Angle which indicates point on wave at which short-circuit occurs.

The instantaneous field current, I_d , is

$$I_d = \frac{x_d - x_d'}{x_d'} I_f \left[\epsilon^{-\frac{t}{T_d'}} - \epsilon^{-\frac{t}{T_a}} \cos 2\pi ft \right] + I_f \quad (27)$$

Where

I_f = Initial value of field current.

III. UNBALANCED CONDITIONS

13. Phase Currents for Unbalanced Short Circuits

As explained in the chapter relating to Symmetrical Components, the unbalanced operating conditions of a rotating machine can for most purposes be described in terms of three characteristic constants: the positive-sequence impedance, the negative-sequence impedance, and the zero-sequence impedance. The short-circuit currents can be resolved, as before, into the steady-state, transient, and subtransient components. The difference between these components decreases exponentially as before. The components of armature current and the time constants for the different kinds of short-circuits are given below for short-circuits at the terminals of the machine.

For three-phase short-circuit:

$$i'' = \frac{e_i''}{x_d''} \quad i' = \frac{e_i'}{x_d'} \quad i = \frac{e_i}{x_d} \quad T_d' = \frac{x_d'}{x_d} T_{do}' \quad (28)$$

For terminal-to-terminal short circuit, the a-c components of the phase currents are given by

$$\begin{aligned}
 i'' &= \frac{\sqrt{3}e_i''}{x_d'' + x_2} & i' &= \frac{\sqrt{3}e_i'}{x_d' + x_2} \\
 i &= \frac{\sqrt{3}e_i}{x_d + x_2} & T_{d'} &= \frac{x_d' + x_2}{x_d + x_2} T_{d'o} \quad (29)
 \end{aligned}$$

in which x_2 is the negative-sequence impedance of the machine

For terminal-to-neutral short circuit, the a-c components of the phase currents are given by

$$\begin{aligned}
 i'' &= \frac{3e_i''}{x_d'' + x_2 + x_0} & i' &= \frac{3e_i'}{x_d' + x_2 + x_0} \\
 i &= \frac{3e_i}{x_d + x_2 + x_0} & T_{d'} &= \frac{x_d' + x_2 + x_0}{x_d + x_2 + x_0} T_{d'o} \quad (30)
 \end{aligned}$$

in which x_0 is the zero-sequence impedance of the machine. The subtransient time constant, $T_{d''}$, does not change significantly with different conditions and, therefore, the single value is used for all conditions. The unidirectional components and the rms values are determined just as described under the general subject of "Short Circuit from Load." The above values of e_i , e_i' and e_i'' will naturally be those values corresponding to the particular load condition.

The ratio of the phase currents for terminal-to-neutral to three-phase short circuits can be obtained from Eq's (30) and (28). Thus, for the phase currents

$$\frac{\text{Terminal-to-neutral short circuit}}{\text{Three-phase short circuit}} = \frac{3x_d''}{x_d'' + x_2 + x_0}$$

The negative-sequence impedance, x_2 , is usually equal to x_d'' , but for many machines x_0 is less than x_d'' . For these cases, the terminal-to-neutral short-circuit current is greater than the three-phase short-circuit current. The generator standards require that the machine be braced only for currents equal to the three-phase values. In order that the terminal-to-neutral current not exceed the three-phase current a reactor should be placed in the neutral of the machine of such value as to bring the zero-sequence impedance of the circuit equal to x_d'' . Thus, the neutral reactor, x_n , should be

$$x_n \geq \frac{1}{3}(x_d'' - x_0)$$

14. Negative-Sequence Reactance

The negative-sequence impedance of a machine is the impedance offered by that machine to the flow of negative-sequence current. A set of negative-sequence currents in the armature creates in the air gap a magnetic field that rotates at synchronous speed in a direction opposite to that of the normal motion of the field structure. Currents of double frequency are thereby established in the field, and in the damper winding if the machine has one. The imaginary component of the impedance is called the negative-sequence reactance and the real component the negative-sequence resistance. These will be discussed separately, in the order mentioned.

If a single-phase voltage is applied across two terminals of a salient-pole machine without dampers while its rotor is stationary, the resulting current is dependent upon the position of the rotor with respect to the pulsating field set

up by the armature current. If the axis of the short-circuited field winding lines up with the axis of pulsating field then the current is large and if the rotor is moved through 90 electrical degrees then the current is much smaller. The first position corresponds to the case of a transformer in which the secondary winding is short-circuited, the field winding in this case corresponding to the secondary winding of the transformer. This is the position in which the subtransient reactance, x_d'' , is determined. It is equal to one-half of the voltage from terminal-to-terminal divided by the current. For the second position the field winding is in quadrature to the pulsating field and consequently no current flows in the field winding. The armature current is then determined by the magnetizing characteristics of the air gap in the quadrature axis. The subtransient reactance, x_q'' , is determined when the field is in this position and is equal to one-half the quotient of the voltage divided by the current. The reactance for intermediate positions varies between these two amounts in accordance with the curve shown in Fig. 29.

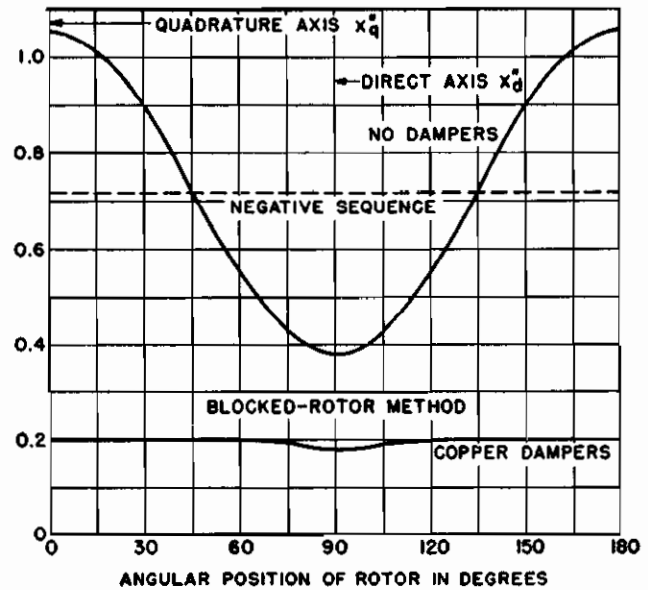

Fig. 29—Relation between subtransient and negative-sequence reactance.

When a set of negative-sequence currents is made to flow through the armature with the field short-circuited and rotating in its normal direction, then the field winding takes different positions successively as the armature field rotates with respect to it. The nature of the impedances in the two extreme positions, that is, where the field winding lines up with the magnetic field and where it is in quadrature with it, should be somewhat the same as x_d'' and x_q'' , the only significant difference being the fact that, in the determination of x_d'' and x_q'' , currents of normal frequency were induced in the field, whereas, in the negative-sequence case the currents are of twice normal frequency. One would expect therefore that the negative-sequence reactance x_2 is some sort of a mean between x_d'' and x_q'' , and such is the case. According to the AIEE test code,¹⁰ the definition of negative-sequence reactance is equal to "the ratio of the fundamental component of re-

active armature voltage, due to the fundamental negative-sequence component of armature current, to this component of armature current at rated frequency." A rigorous interpretation of this definition results in x_2 equal to the arithmetic mean $\frac{x_q'' + x_d''}{2}$. However, several different definitions can be given for x_2 . That this is possible is dependent largely upon the fact that when a sinusoidal set of negative-sequence voltages is applied to the armature the currents will not be sinusoidal. Conversely if the currents are sinusoidal the voltages will not be.

In Table 1 are shown expressions¹¹ for x_2 based upon different definitions. This table is based on a machine without damper windings for which x_q'' is equal to x_q , and x_d'' is equal to x_d' . In this table

$$b = \frac{\sqrt{x_q} - \sqrt{x_d}}{\sqrt{x_q} + \sqrt{x_d}}$$

For each test condition it is possible to establish definitions based on whether fundamental or root-mean-square currents are specified. For example, in the first definition if the fundamental component of armature current is used in calculating x_2 then the expression in the first column should be used, but if the root-mean-square figure of the resultant current is used then the expression in the second column should be used.

In order to orient one's self as to the relative importance of the different expressions, figures have been inserted in the expressions given in Table 1 for a typical machine having the constants $x_d' = 35\%$, $x_q = 70\%$, and $x_d = 100\%$. The magnitudes are tabulated in the righthand columns of Table 1. From the standpoint of practical application, the negative-sequence reactance that would result in the proper root-mean-square current for method (3) would appear to be the most important. However, the method of test to determine this quantity involves a sudden short-circuit and from this standpoint proves rather inconvenient. On the other hand, the figure for x_2 obtained from the use of the root-mean-square values in a sustained single-phase short-circuit current [method (4)], is nearly equal to this quantity. When the resistance is negligible this negative-sequence reactance is equal to

$$x_2 = \frac{\sqrt{3}E}{I} - x_d \tag{31}$$

where I equals the root-mean-square armature current in the short-circuited phase; and E equals the root-mean-square open-circuit voltage between terminals before the short-circuit is applied or the no-load voltage corresponding to the field current at which I is read.

In general, the same arguments can be applied to other types of machines such as turbine generators and salient-pole machines with damper windings when the parameters x_d'' and x_q'' are used. For such machines the difference between x_q'' and x_d'' is not great. The values for x_q'' and x_d'' of a machine with copper dampers are given in Fig. 29. For such machines the difference between x_2 based on the different definitions of Table 1 will become inconsequential. In addition, for turbine generators, saturation introduces variables of much greater magnitude than those just considered. For these machines negative-sequence reactance can be taken equal to x_d'' .

Method of Test—In addition to the method implied by the AIEE Code and the ASA whereby x_2 is defined as the arithmetic mean for x_d'' and x_q'' , x_2 can be determined directly from test either by applying negative-sequence voltage or by the method shown in Fig. 30.

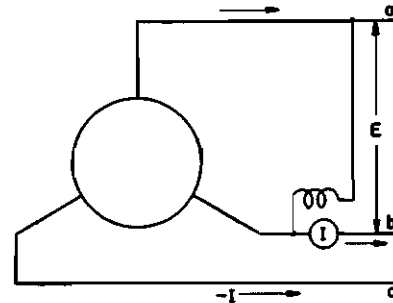

$$I_a = 0 \quad I_b = I \quad I_c = -I \quad I_{a2} = \frac{1}{3}(0 + a^2I - aI) = \frac{a^2 - a}{3}I$$

$$E_A = 0 \quad E_B = E \quad E_C = -E \quad E_{A2} = \frac{1}{3}(0 + a^2E - aE) = \frac{a^2 - a}{3}E$$

$$E_{a2} = j \frac{E_{A2}}{\sqrt{3}} = \frac{j(a^2 - a)}{3\sqrt{3}}E \quad z_2 = \frac{E_{a2}}{I_{a2}} = \frac{jE}{I\sqrt{3}}$$

If $\phi = \cos^{-1} \frac{P}{EI}$, where P = wattmeter reading,

$$\text{then, } z_2 = \frac{E}{\sqrt{3}I}(\sin \phi + j \cos \phi) = r_2 + jx_2$$

Fig. 30—Determination of the negative-sequence impedance of symmetrically-wound machines.

TABLE 1—DEFINITIONS OF NEGATIVE-SEQUENCE REACTANCE

Definition	Analytical Expressions		Numerical Values $x_d' = 35\%$ $x_q = 70\%$ $x_d = 100\%$	
	Funda- mental	Root-Mean-Square	Funda- mental	Root-Mean- Square
(1) Application of sinusoidal negative-sequence voltage	$\frac{2x_d'x_q}{x_q + x_d'}$	$\frac{\sqrt{2}x_d'x_q}{\sqrt{x_q^2 + x_d'^2}}$	47	44
(2) Application of sinusoidal negative-sequence current	$\frac{x_q + x_d'}{2}$	$\frac{1}{2} \sqrt{(x_q + x_d')^2 + 9(x_q - x_d')^2}$	53	74
(3) Initial symmetrical component of sudden single-phase short-circuit current	$\sqrt{x_d'x_q}$	$x_d' \sqrt{1 - b^2} - 1 + \sqrt{x_d'x_q} \sqrt{1 - b^2}$	50	48
(4) Sustained single-phase short-circuit current	$\sqrt{x_d'x_q}$	$x_d' (\sqrt{1 - b^2} - 1) + \sqrt{x_d'x_q} \sqrt{1 - b^2}$	50	47
(5) Same as (4) with 50% external reactance			51	50
(6) A.I.E.E. and A.S.A.	$\frac{x_q + x_d'}{2}$		53	

With the machine driven at rated speed, and with a single-phase short-circuit applied between two of its terminals (neutral excluded) the sustained armature current and the voltage between the terminal of the free phase and either of the short-circuited phases are measured. The reading of a single-phase wattmeter with its current coil in the short-circuited phases and with the above mentioned voltage across its potential coil is also recorded. The negative-sequence impedance equals the ratio of the voltage to the current so measured, divided by 1.73. The negative-sequence reactance equals this impedance multiplied by the ratio of power to the product of voltage and current.

15. Negative-Sequence Resistance

The power associated with the negative-sequence current can be expressed as a resistance times the square of the current. This resistance is designated the negative-sequence resistance. For a machine without damper windings the only source of loss is in the armature and field resistances, eddy currents, and iron loss. The copper loss in the armature and field is small as is also the iron and eddy loss in the armature, but the iron and eddy loss in the rotor may be considerable. Copper damper windings provide a lower impedance path for the eddy currents and hinder the penetration of flux into the pole structure. The relatively low resistance of this path results in a smaller negative-sequence resistance than if the flux were permitted to penetrate into the rotor. For higher resistance damper windings the negative-sequence resistance increases to a point beyond which the larger resistance diminishes the current in the rotor circuits sufficiently to decrease the loss.

Induction-Motor Diagram—The nature of the negative-sequence resistance is best visualized by analyzing the phenomena occurring in induction motors. In Fig. 31

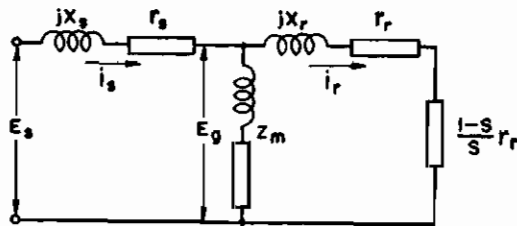

Fig. 31—Equivalent circuit of induction motor.

is given the usual equivalent circuit of an induction motor in which

- r_s = stator resistance.
- x_s = stator-leakage reactance at rated frequency.
- r_r = rotor resistance.
- x_r = rotor-leakage reactance at rated frequency.
- z_m = shunt impedance to include the effect of magnetizing current and no-load losses.
- E_s = applied voltage.
- I_s = stator current.
- I_r = rotor current.
- s = slip.

The justification for this diagram is shown briefly as follows: The air-gap flux created by the currents I_s and I_r

induces the voltage E_g in the stator and sE_g in the rotor. In the rotor the impedance drop is

$$r_r I_r + j s x_r I_r \quad (32)$$

since the reactance varies with the frequency of the currents in the rotor. The rotor current is therefore determined by the equation

$$s E_g = r_r I_r + j s x_r I_r$$

or

$$E_g = \frac{r_r}{s} I_r + j x_r I_r \quad (33)$$

It follows from this equation that the rotor circuit can be completely represented by placing a circuit of impedance

$\frac{r_r}{s} + j x_r$ across the voltage E_g . The total power absorbed by

$\frac{r_r}{s}$ must be the sum of the rotor losses and the useful shaft

power, so that, resolving $\frac{r_r}{s}$ into the resistances r_r and

$\frac{1-s}{s} r_r$, the power absorbed by r_r represents the rotor cop-

per loss. The power absorbed by $\frac{1-s}{s} r_r$ represents the useful shaft power.

Neglecting r_s and the real part of z_m , the only real power is that concerned in the rotor circuit. Assume that the induction motor drives a direct-current generator. At small slips the electrical input into the stator is equal to the copper loss, i.e., the $I_r^2 r_r$ of the rotor plus the shaft load. With the rotor locked, the shaft load is zero, and the total electrical input into the stator is equal to the rotor copper loss. At 200-percent slip, i.e., with the rotor turning at synchronous speed in the reverse direction, the copper loss is $I_r^2 r_r$, the electrical input into the stator is $\frac{I_r^2 r_r}{2}$,

and the shaft load $\frac{1-2}{2} r_r I_r^2$ or $-\frac{I_r^2 r_r}{2}$. A negative shaft

load signifies that the direct-current machine instead of functioning as a generator is now a motor. Physically that is just what would be expected, for as the slip increases from zero the shaft power increases to a maximum and then decreases to zero for 100-percent slip. A further increase in slip necessitates motion in the opposite direction, which requires a driving torque. At 200-percent slip the electrical input into the stator is equal to the mechanical input through the shaft; half of the copper loss is supplied from the stator and half through the shaft. This is the condition obtaining with respect to the negative-sequence in which the rotor is rotating at a slip of 200 percent relative to the synchronously rotating negative-sequence field in the stator. Half of the machine loss associated with the negative-sequence current is supplied from the stator and half by shaft torque through the rotor.

The factors of fundamental importance are the power supplied to the stator and the power supplied to the shaft, which can always be determined by solving the equivalent circuit involving the stator and rotor constants and the magnetizing-current constants. A more convenient device,

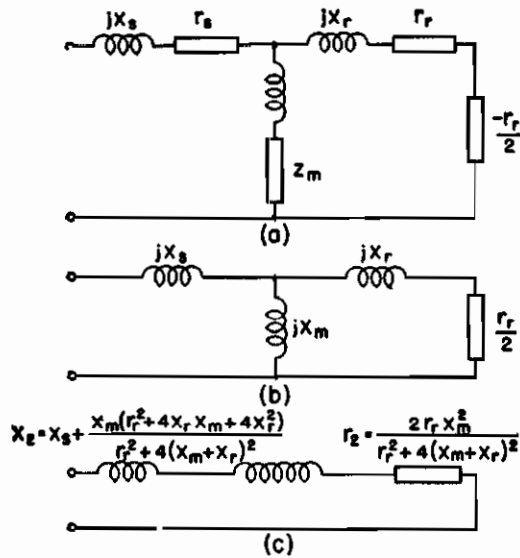

Fig. 32—Development of negative-sequence resistance and reactance from equivalent circuit of induction motor. (a) Negative-sequence diagram for induction motor; (b) neglecting armature and no load losses; (c) simplified network-negative-sequence resistance and reactance.

since s is constant and equal to 2 for the negative-sequence, is to reduce the equivalent network to a simple series impedance as shown in Fig. 32 (c). The components of this impedance will be called the negative-sequence resistance r_2 , and the negative-sequence reactance x_2 . The current flowing through the negative-sequence impedance is the current flowing through the stator of the machine, and the power loss in r_2 is equal to the loss supplied from the stator of the machine and the equal loss supplied through the shaft.

The total electrical effect of the negative-sequence resistance in system analysis problems is obtained by inserting the negative-sequence resistance in the negative-sequence network and solving the network in the usual manner. All three of the sequence currents are thus affected to some extent by a change in the negative-sequence resistance. The total electrical output of a generator, not including the shaft torque developed by negative-sequence current, is equal to the total terminal power output plus the losses in the machine. However, the negative- and zero-sequence power outputs are merely the negative of their losses. In other words, their losses are supplied by power flowing into the machine from the system. Therefore, the contribution of the negative- and zero-sequences to the electrical output is zero. The total electrical output reduces then to that of the positive-sequence and to include the positive-sequence armature-resistance loss it is necessary only to use the positive-sequence internal voltage in the calculations. Or viewed differently, since there are no internal generated voltages of the negative- or zero-sequence, the corresponding internal power must be zero. In addition to this electrical output, which produces a torque tending to decelerate the rotor, there also exists the negative-sequence shaft power supplied through the rotor. It was shown that this power tending to decelerate the rotor is numerically equal to the negative-sequence power

supplied to the stator, which, in turn is equal to the loss absorbed by the negative-sequence resistance. Therefore, the total decelerating power is equal to the positive-sequence power output plus the loss in the negative-sequence resistance.

The assumption was made that the stator resistance and the losses in the magnetizing branch were neglected. For greater refinements, the stator resistance and the losses in the magnetizing branch can be taken into consideration by substituting them in the equivalent circuit and reducing that circuit to simple series resistance and reactance, wherein the resistance becomes the negative-sequence resistance and the reactance the negative-sequence reactance. The ratio of the negative-sequence shaft power to the loss in the negative-sequence resistance is then equal to the ratio of the power loss in $\frac{r_r}{2}$ for unit negative-sequence current in the stator to r_2 . This ratio can be obtained easily by test by measuring the shaft torque and the negative-sequence input when negative-sequence voltages only are applied to the stator.

While this analysis has premised induction-motor construction, the conclusions can also be applied to synchronous machines.

Method of Test—While r_2 and x_2 can be determined by applying negative-sequence voltage from another source of supply to the armature, the following method has the advantage that the machine supplies its own negative-sequence voltage. Two terminals of the machine under test are short-circuited and the machine driven at rated frequency by means of a direct-current motor. The equivalent circuit and vector diagram for this connection are shown in Fig. 33. The positive-sequence power per phase at the terminals is equal to the product of \bar{E}_1 and \bar{I}_1 and the cosine of the angle ϕ . This power is positive. However, the negative-sequence power output per phase is equal to the product of \bar{E}_2 , \bar{I}_2 , and the cosine of the angle between E_2 and I_2 , and since $I_2 = -I_1$, and $E_1 = E_2$, the negative-

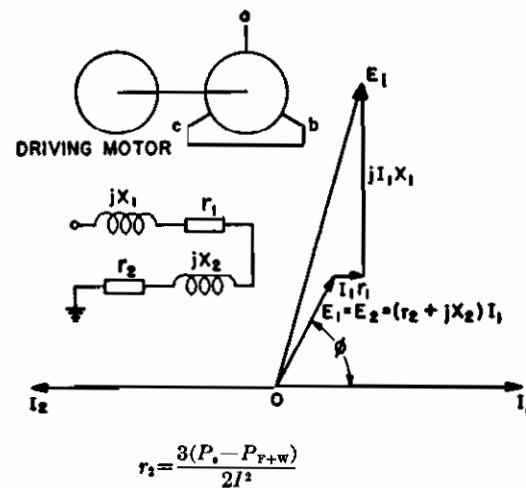

$$r_2 = \frac{3(P_s - P_{f+w})}{2I_1^2}$$

in which

P_s = shaft input.
 P_{f+w} = friction and windage loss.

Fig. 33—Negative-sequence resistance of a synchronous machine.

sequence power output is the negative of the positive-sequence power output, which, of course, must follow since the output of the machine is zero. A negative output is equivalent to a positive input. This input is equal to $r_2 \bar{I}_2^2$ per phase. Therefore, the positive-sequence terminal output per phase is $r_2 \bar{I}_2^2$, and adding to this the copper loss due to I_1 , gives the total shaft power due to the positive-sequence as $3(r_2 \bar{I}_2^2 + r_1 \bar{I}_1^2)$.

Now from Fig. 32(a), if z_m be neglected the negative-sequence input per phase is equal to

$$\left(r_r + r_s - \frac{r_r}{2}\right) \bar{I}_2^2 \text{ or } \left(\frac{r_r}{2} + r_s\right) \bar{I}_2^2$$

from which it follows that

$$r_2 = \frac{r_r}{2} + r_s \quad (34)$$

As shown previously the negative-sequence shaft power per phase is equal to $\frac{r_r \bar{I}_2^2}{2}$, which on substituting $\frac{r_r}{2}$ from (34) reduces to $(r_2 - r_s) \bar{I}_2^2$. But since $r_s = r_1$, the expression for the negative-sequence shaft power per phase can also be written $(r_2 - r_1) \bar{I}_2^2$. Incidentally, from this the rotor losses are equal to $2(r_2 - r_1) \bar{I}_2^2$. Therefore the total shaft input into the alternating-current machine is equal to $3[r_2 \bar{I}_2^2 + r_1 \bar{I}_1^2 + (r_2 - r_1) \bar{I}_2^2]$ and, since $\bar{I}_1 = \bar{I}_2$, reduces to $6r_2 \bar{I}_2^2$.

Including the effect of friction and windage, $P_{(F+W)}$, and calling P_s the total input into the alternating-current machine from the driving tool,

$$r_2 = \frac{P_s - P_{(F+W)}}{6\bar{I}_2^2} \quad (35)$$

and, since $\bar{I}_2 = \frac{I}{\sqrt{3}}$ where I is the actual measured phase current,

$$r_2 = \frac{[P_s - P_{(F+W)}]}{2I^2} \quad (36)$$

The foregoing neglects the effects of saturation. Tests on salient pole machines with and without dampers verify the fact that the loss varies as the square of the negative-sequence currents. The loss for turbine generators, on the other hand, varies as the 1.8 power of current.

16. Zero-Sequence Impedance

The zero-sequence impedance is the impedance offered to the flow of unit zero-sequence current, i.e., the voltage drop across any one phase (star-connected) for unit current in each of the phases. The machine must, of course, be star-connected for otherwise no zero-sequence current can flow.

The zero-sequence reactance of synchronous machines is quite variable and depends largely upon pitch and breadth factors. In general, however, the figures are much smaller than those of positive and negative sequences. The nature of the reactance is suggested by considering that, if the armature windings were infinitely distributed so that each phase produced a sinusoidal distribution of the mmf, then the mmfs produced by the equal instantaneous currents of the three phases cancel each other and produce zero field and consequently zero reactance except for slot and

end-connection fluxes. The departure from this ideal condition introduced by chording and the breadth of the phase belt determines the zero-sequence reactance.

The zero-sequence resistance is equal to, or somewhat larger than, the positive-sequence resistance. In general, however, it is neglected in most calculations.

Method of Test—The most convenient method for test of zero-sequence impedance is to connect the three phases together, as shown in Fig. 34, with the field short-

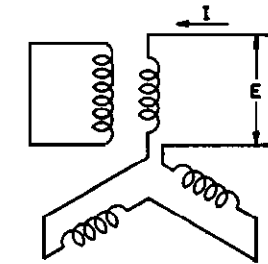

Rotor at synchronous speed
(or blocked)

$$\text{Zero-sequence impedance, } Z_0 = \frac{E}{3I}$$

Fig. 34—Connection for measuring zero-sequence impedance.

circuited. This connection insures equal distribution of current between the three phases. For this reason it is preferable to connecting the three phases in parallel. The zero-sequence impedance is then equal to $Z_0 = \frac{E}{3I}$ as indicated in the illustration.

IV. PER UNIT SYSTEM

The performance of a whole line of apparatus, regardless of size, can often be expressed by a single set of constants when those constants are expressed in percentages. By this is meant that the loss will be a certain percentage of its kilowatt rating, its regulation a certain percentage of its voltage rating, etc. The advantage of this method of representation extends to a better comparison of performance of machines of different rating. A 100-volt drop in a transmission line has no significance until the voltage base is given, whereas, as a percentage drop would have much significance.

A disadvantage of the percentage system is the confusion that results from the multiplication of percentage quantities. Thus, a 20-percent current flowing through a 40-percent reactance would by simple multiplication give 800 which at times is erroneously considered as 800-percent voltage drop, whereas, the correct answer is an 8-percent voltage drop.

The per unit system⁴ of designation is advanced as possessing all the advantages of the percentage system but avoids this last mentioned disadvantage. In this system the rating quantity is regarded as unity. Any other amount of the quantity is expressed as a fraction of the rated amount. It is the same as the percentage system except that unity is used as a base instead of 100. The foregoing

multiplication example would in the per unit system be expressed as follows: A 0.20 per unit current flowing through a 0.40 per unit reactance produces an 0.08 per unit voltage drop, which is correct.

A further advantage of the percentage and per unit systems lies in the elimination of troublesome coefficients. However, this is not an unmixed blessing as a definite disadvantage of the use of the per unit system lies in the loss of the dimensional check.

V. POWER EXPRESSIONS

It is frequently necessary to know the manner in which the power output of a machine varies with its excitation and internal angle. A particular application of this knowledge is the stability problem. Several simple cases will be considered.

17. Machine Connected through Reactance to Infinite Bus and also Shunt Reactance across its Terminals, Resistance of Machine Neglected

The schematic diagram for this case is shown in Fig. 35(a), which also shows the significance of the various symbols to be used in this discussion. The reactances x_s , x_c , and the one indicated by the dotted lines represent the branches of an equivalent π circuit, for which the resistance components are neglected. For the purposes of determining the power output of the generator the reactance shown dotted can be neglected. The vector diagram which applies is Fig. 35(b). The total machine current is equal to i ,

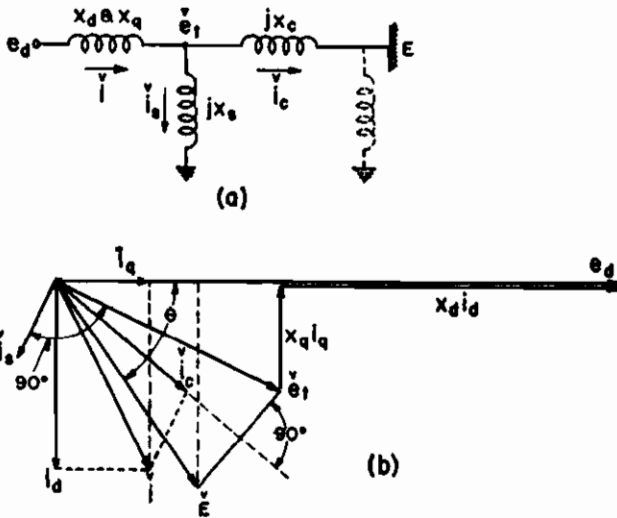

Fig. 35—Machine connected to infinite bus through a reactance.

which from the internal and external currents one can obtain*

$$i_q - ji_d = \check{i}_s + \check{i}_c$$

And inserting the equivalents of \check{i}_s and \check{i}_c

$$i_q - ji_d = \frac{\check{e}_t}{jx_s} + \frac{\check{e}_t - \check{E}}{jx_c}$$

*The symbol caret over a quantity indicates a phasor quantity.

$$= -j \left(\frac{x_s + x_c}{x_s x_c} \right) \check{e}_t + j \frac{\check{E}}{x_c} \quad (37)$$

But
and

$$\begin{aligned} \check{e}_t &= e_d - x_d i_d - j x_q i_q \\ \check{E} &= E \cos \theta - j E \sin \theta \end{aligned}$$

Upon substituting \check{e}_t and E in equation (37), there results

$$\begin{aligned} i_q - ji_d &= -j \left(\frac{x_s + x_c}{x_s x_c} \right) [e_d - x_d i_d - j x_q i_q] \\ &\quad + j \frac{1}{x_c} [E \cos \theta - j E \sin \theta] \end{aligned} \quad (38)$$

Equating reals

$$\begin{aligned} i_q &= - \frac{x_q (x_s + x_c)}{x_s x_c} i_q + \frac{E \sin \theta}{x_c} \\ &= \frac{x_s E \sin \theta}{x_s x_c + x_q x_s + x_q x_c} \end{aligned} \quad (39)$$

And equating imaginaries

$$\begin{aligned} i_d &= \frac{x_s + x_c}{x_s x_c} [e_d - x_d i_d] - \frac{1}{x_c} E \cos \theta \\ &= \frac{(x_s + x_c) e_d - x_s E \cos \theta}{x_s x_c + x_d x_s + x_d x_c} \end{aligned} \quad (40)$$

The power output, P , is equal to the sum of the products of the in-phase components of armature current and terminal voltage, namely

$$\begin{aligned} P &= i_q (e_d - x_d i_d) + i_d (x_q i_q) \\ &= e_d i_q + (x_q - x_d) i_d i_q \\ &= [e_d + (x_q - x_d) i_d] i_q \end{aligned} \quad (41)$$

The power is then obtained by calculating i_q and i_d from (39) and (40) and inserting into (41). If E and e_d are expressed in terms of rms volts to neutral and reactances in ohms per phase, then the above expression gives the power in watts per phase; but if the emf's are expressed in terms of the phase-to-phase volts the expression gives total power. On the other hand, if all quantities are expressed in p.u. then the power is also expressed in p.u. where unity is equal to the kva rating of the machine. If e_d' rather than e_d is known then e_d should be replaced by e_d' and x_d by x_d' wherever they appear in Eqs. (40) and (41).

For the special case of a machine with cylindrical rotor in which $x_q = x_d$, the expression reduces immediately to

$$\begin{aligned} P &= e_d i_q \\ &= \frac{x_s E e_d \sin \theta}{x_s x_c + x_q x_s + x_q x_c} \end{aligned} \quad (42)$$

Another interesting special case is that for which the shunt reactance is not present or $x_s = \infty$. Then

$$\begin{aligned} P &= \left[e_d + (x_q - x_d) \frac{e_d - E \cos \theta}{x_c + x_d} \right] \frac{E \sin \theta}{x_c + x_q} \\ &= \frac{e_d E \sin \theta}{x_c + x_d} + \frac{(x_d - x_q) E^2 \sin 2\theta}{2(x_d + x_c)(x_q + x_s)} \end{aligned} \quad (43)$$

And if $x_s = 0$ and $x_c = \infty$, then

$$P = \frac{e_d E \sin \theta}{x_d} + \frac{(x_d - x_q) E^2 \sin 2\theta}{2x_d x_q} \quad (44)$$

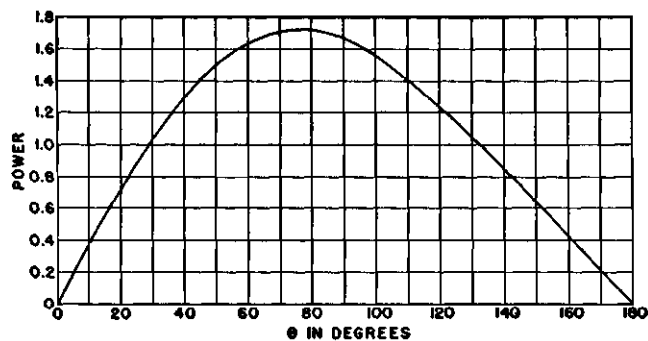

Fig. 36—Power-angle diagram of a salient-pole machine—excitation determined to develop rated kva at 80-percent power factor. $x_d=1.15$; $x_q=0.75$.

In Fig. 36 is shown a power-angle diagram of a salient-pole machine whose excitation is determined by loading at full kva at 80-percent power factor.

An expression frequently used to determine the maximum pull-out of turbine generators is the following

$$\text{Pull-out in kw} = \frac{OC}{OD} (\text{rating of generator in kva})$$

where OC is the field current for the particular operating condition and OD is the field current for the rated-current zero-power factor curve for zero terminal voltage (see Fig. 17). This expression is based upon the maintenance of rated terminal voltage up to the point of pull-out. At pull-out the angle δ of Fig. 15 is equal to 90 degrees. Since the extent of saturation is measured by the voltage behind the Potier reactance drop, it can be seen from Fig. 15 that for δ equal to 90 degrees this voltage is less than rated voltage, and that therefore little saturation is present. From Eq. (44) since $x_d = x_q$ and $\theta = 90$ degrees, the pull-out is $\frac{e_a E}{x_d}$. But e_a is proportional to OC on the air-gap line and x_d is likewise proportional to OD on the air-gap line.

Examination of Eq. (44) shows that even if the excitation is zero ($e_a = 0$) the power-angle curve is not equal to zero, but equal to $\frac{(x_d - x_q) E^2 \sin 2\theta}{2x_d x_q}$. This results from the

effects of saliency. Note that it disappears for uniform air-gap machines for which $x_d = x_q$. Advantage is sometimes taken of this relation in the case of synchronous condensers to obtain a somewhat greater capability in the leading (under-excited) kva range. With some excitation systems (see Chap. 7, Excitation Systems) it is possible to obtain negative excitation. The excitation voltage, e_a , in Eq. (44) can be somewhat negative without producing an unstable power-angle diagram. By this device the leading kva range can be increased as much as 15 or 20 percent.

18. Inclusion of Machine Resistance or External Resistance

If the machine is connected to an infinite bus through a resistance and reactance circuit, the external resistance and reactance can be lumped with the internal resistance and reactance and the following analysis used. The vector diagram for this case is shown in Fig. 37 for which

$$e_t \sin \theta + r i_d - x_q i_q = 0 \quad (45)$$

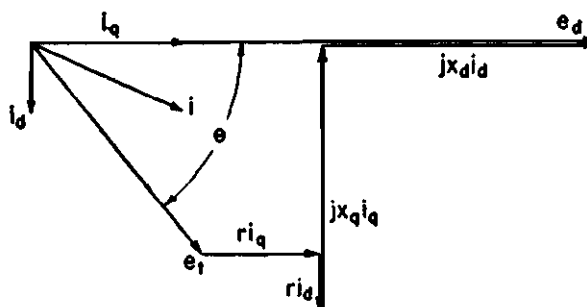

Fig. 37—Vector diagram of salient-pole machine including effect of series resistance.

$$e_t \cos \theta + r i_q + x_d i_d - e_d = 0 \quad (46)$$

From (45)

$$i_q = \frac{1}{x_q} (e_t \sin \theta + r i_d) \quad (47)$$

Substituting (47) into (46)

$$e_t \cos \theta + \frac{r}{x_q} e_t \sin \theta + \frac{r^2}{x_q} i_d + x_d i_d - e_d = 0$$

from which

$$i_d = \frac{1}{r^2 + x_d x_q} [x_q e_d - r e_t \sin \theta - x_q e_t \cos \theta] \quad (48)$$

and substituting in (47)

$$i_q = \frac{1}{r^2 + x_d x_q} [r e_d + x_d e_t \sin \theta - r e_t \cos \theta] \quad (49)$$

The power output, P , is equal to the sum of the products of the in-phase components of i and e_t , or

$$P = i_q e_t \cos \theta + i_d e_t \sin \theta \quad (50)$$

Upon substituting (48) and (49) this reduces to

$$P = \frac{e_t}{r^2 + x_d x_q} \left[e_d (r \cos \theta + x_q \sin \theta) + \frac{x_d - x_q}{2} e_t \sin 2\theta - r e_t \right] \quad (51)$$

The power input into the machine is equal to P plus $r i^2$. The expression for this quantity does not simplify and it is better to calculate it through the intermediate step of evaluating $r i^2$, which is equal to $r(i_d^2 + i_q^2)$.

The foregoing expressions apply to the steady-state conditions. In stability problems it is necessary to determine the average power from instant to instant. In general for this purpose it is permissible to neglect both the unidirectional component of currents and the subtransient component of the alternating current, leaving only the transient component. These latter are determined by the instantaneous value of e_d' . It follows then that the power expressions are simply those derived for the steady-state condition with e_d replaced by e_d' and x_d by x_d' .

VI. EFFECT OF CHANGE IN EXCITATION

Field forcing in certain industrial applications and considerations of system stability require that the voltage increase in response to a sudden need. This increase is brought about automatically either by means of the same

control that produced the increase in load or through the use of a voltage regulator. It is necessary, therefore, to be able to predetermine the effect of an increase in exciter voltage upon the output of the synchronous machine. In general, significant changes in exciter voltage never require less than about one-tenth of a second to bring about the change. By the time this effect has been felt through the synchronous machine, which has a time constant of about a second, it will be found that the result is always slow when compared to the subtransient and unidirectional components of the transients associated with the change. In other words, variations in exciter voltage are reflected only in the transient components. As an example, suppose it is desired to calculate the armature current of a machine for a three-phase short-circuit while it is operating at no load with a voltage regulator set for rated voltage.

Immediately after the inception of the short circuit there is a slight lag in the regulator until its contacts and relays close. The exciter voltage (and voltage across the field of the main machine) then rises as shown in the upper curve of Fig. 38. The bottom curve refers to the armature cur-

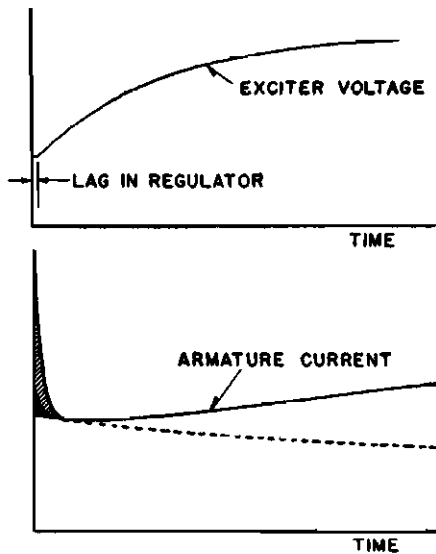

Fig. 38—Illustration showing relative importance of different components of armature short-circuit current and response of transient component to the exciter voltage.

rent, the dotted line showing the nature of transient component if there were no regulator, the exciter voltage remaining constant. The line immediately above shows how the transient component changes as a result of the change in exciter voltage. To approximately the same scale, the cross-hatched area shows the increment in current caused by subtransient effects. The blackened area shows how the unidirectional component would contribute its effect. This component is quite variable and for a short-circuit on the line might be entirely completed in a cycle or less. In any event regardless of its magnitude it can be merely added to the transient and subtransient component. It is independent of the exciter voltage.

19. Fundamental Equation

Being restricted to the transient component, the effect of exciter response can then be defined entirely by effects in

the field circuit. The beauty of the per unit system is exemplified in the analysis of this problem. In p.u. the differential equation for the field circuit takes the following form

$$e_x = e_d + T'_{do} \frac{de_d'}{dt} \quad (52)$$

In this equation e_x represents the exciter voltage or the voltage across the field if there is no external field resistor in the field circuit. The unit of e_x is that voltage required to circulate such field current as to produce rated voltage at no load on the air-gap line of the machine. The term e_d is the synchronous internal voltage necessary to produce the instantaneous value of armature current for the given armature circuit regardless of what it may be. Its unit is rated voltage. It is synonymous with field current when unit field current is that field current necessary to produce rated voltage at no load on the air-gap line. It will be seen then that the use of e_d is merely a convenient way of specifying the instantaneous field current during the transient conditions; it is the field current necessary to produce the armature current existent at that instant. As shown previously, e_d' is proportional to the flux linkages with the field winding. It is the quantity that, during the transition period from one circuit condition to another, remains constant. The foregoing equation has its counterpart in the more familiar forms

$$e_x = Ri + N(10^{-8}) \frac{d\phi}{dt} \quad (53)$$

or

$$e_x = Ri + L \frac{di}{dt} \quad (54)$$

To familiarize the reader with (52), suppose that normal exciter voltage is suddenly applied to the field winding at no load. Since the armature is open-circuited e_d' and e_d are equal and the equation can be written

$$e_x = e_d + T'_{do} \frac{de_d}{dt} \quad (55)$$

When steady-state conditions are finally attained $\frac{de_d}{dt}$ is equal to zero and $e_d = e_x$. This states that since $e_x = 1.0$, e_d must also equal 1.0, that is, the excitation is equal to the normal no-load voltage. It will attain this value exponentially with a time constant T'_{do} .

Another example. Suppose the synchronous machine to be short-circuited from no-load and to be operating without a regulator. At any instant the armature current, i , is equal to e_d'/x_d' . But since e_d , which can be regarded as the instantaneous field current required to produce i , is equal to $x_d i$, then eliminating i between these equations

$$e_d = \frac{x_d}{x_d'} e_d' \quad (56)$$

Then equation (52) takes the form

$$1 = \frac{x_d}{x_d'} e_d' + T'_{do} \frac{de_d'}{dt}$$

the curve marked E is the instantaneous magnitude of E from time $t=0$. Plot $\frac{E}{R}$ displaced to the right a time T .

Let I_1 be the initial value of I at $t=0$. Divide the time into intervals of length Δt . Draw the line ab , then cd , ef , etc. The accuracy will be greater the smaller the intervals and can be increased somewhat for a given element width by using $T - \frac{\Delta t}{2}$ instead of T for the distance by which the steady-state curve which I tends to approach, is offset horizontally.

Now returning to the problem in hand. The differential equation governing the case is given by (52). The exciter voltage e_x is assumed given and expressed in p.u. For a three-phase short circuit at the terminals of the machine e_a is equal to $x_d i$ and $e_a' = x_d' i$. Therefore Eq. 52 becomes

$$e_x = x_d i + x_d' T_{d0}' \frac{di}{dt} \quad (62)$$

Dividing through by x_d

$$\frac{e_x}{x_d} = i + \frac{x_d'}{x_d} T_{d0}' \frac{di}{dt} \quad (63)$$

The construction dictated by this equation and the follow-up method is shown in Fig. 41. $\frac{e_x}{x_d}$ is plotted against

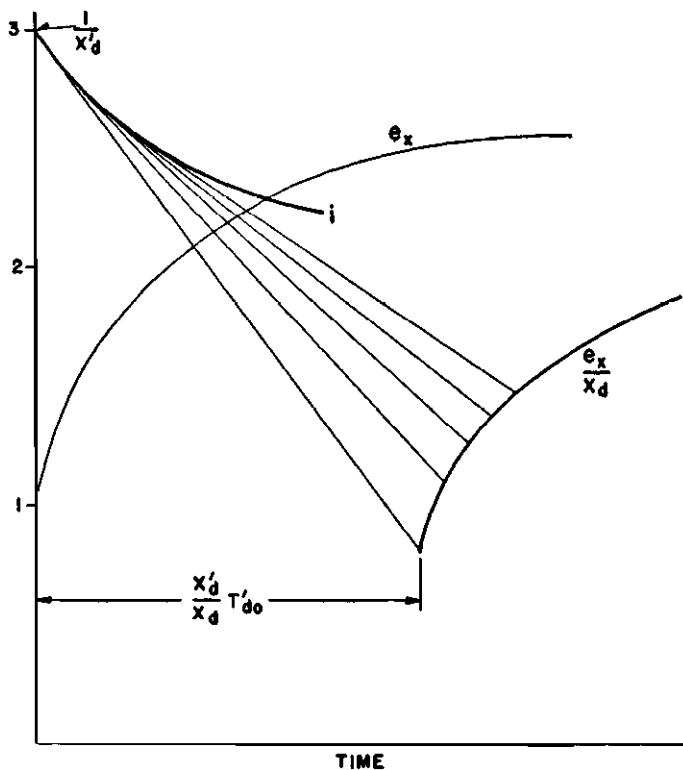

Fig. 41—Transient component of short-circuit current, i' , as influenced by excitation.

time, its zero being displaced an interval $\frac{x_d'}{x_d} T_{d0}'$ from reference zero. The initial value of i is determined through e_a' which was 1.0 at $t=0$. This makes the initial amount of

$i = \frac{1}{x_d'}$. Starting from this value the actual magnitude of i is obtained as a function of time.

21. Unsaturated Machine Connected to Infinite Bus

As stated previously the subtransient and unidirectional components of current are not of importance in the stability problem. For this application it is desirable to determine how e_a' varies as this influences the power output of the machine and in turn dictates the degree of acceleration or deceleration of the rotor. The circuit shown in Fig. 35(a) is typical of a setup that might be used for an analytical study to determine the effect of exciter response in increasing stability limits. Another case of considerable importance is the action of a generator when a heavy load, such as a large induction motor, is connected suddenly across its terminals or across the line to which it is connected. In starting the motor the line voltage may drop an excessive amount. The problem might be to determine the amount to which this condition could be ameliorated by an appropriate excitation system. Since reactive kva is more important than the real power in determining regulation, the motor can be represented as a reactor and the circuit in Fig. 35(a) utilized. Having determined the manner in which e_a' varies, the power in the case of the stability problem and the terminal voltage ($e_a' - x_d' i$) in the case of the voltage problem, can be calculated easily. Equation (52) must be used again to determine the manner in which e_a' varies in response to changes in exciter voltage and phase position of the rotor with respect to the infinite bus. The instantaneous armature current can be found in terms of the rotor angle θ and e_a' by replacing e_a and x_d of Eq. (40) by e_a' and x_d' , respectively, giving

$$i_d = \frac{(x_s + x_c) e_a' - x_s E \cos \theta}{x_s x_c + x_d' x_s + x_d' x_c} \quad (64)$$

The synchronous internal voltage, e_d , is equal at any instant to

$$e_d = e_a' + (x_d - x_d') i_d \quad (65)$$

and upon substituting (64)

$$\begin{aligned} e_d &= e_a' + (x_d - x_d') \frac{(x_s + x_c) e_a' - x_s E \cos \theta}{x_s x_c + x_d' x_s + x_d' x_c} \\ &= \frac{(x_s x_c + x_d x_s + x_d x_c) e_a' - x_s (x_d - x_d') E \cos \theta}{x_s x_c + x_d' x_s + x_d' x_c} \end{aligned}$$

Substituting this expression in (52), there results.

$$\begin{aligned} e_x &= \frac{x_s x_c + x_d x_s + x_d x_c}{x_s x_c + x_d' x_s + x_d' x_c} e_a' - \\ &\quad \frac{x_s (x_d - x_d')}{x_s x_c + x_d' x_s + x_d' x_c} E \cos \theta + T_{d0}' \frac{de_a'}{dt} \end{aligned} \quad (66)$$

which can be converted to

$$\frac{T_{d0}'}{T_{d0}'} e_x + \frac{x_s (x_d - x_d')}{x_s x_c + x_d x_s + x_d x_c} E \cos \theta = e_a' + T_{d0}' \frac{de_a'}{dt} \quad (67)$$

in which

$$T_{d0}' = \frac{x_s x_c + x_d' x_s + x_d' x_c}{x_s x_c + x_d x_s + x_d x_c} T_{d0}' \quad (68)$$

The time constant T_{d0}' is the short-circuit transient time constant.

If θ were constant or if its motion as a function of time were known then the whole left-hand side could be plotted (displaced by the time T_d') and treated by the follow-up method as the quantity that e_d' tends to approach. Unfortunately θ is not in general known beforehand, and it is necessary to calculate θ simultaneously in small increments in a simultaneous solution of e_d' and θ . The magnitude of θ is determined by the electro-mechanical considerations discussed in the chapter dealing with System Stability. In solving for e_d' a progressive plot of the left-hand side can be made or (67) can be transformed to the following form

$$\frac{de_d'}{dt} = \frac{1}{T_d'} \left[\frac{T_d'}{T_{do}'} e_x + \frac{x_s(x_d - x_d')}{x_s x_o + x_d x_s + x_d x_o} E \cos \theta - e_d' \right] \quad (69)$$

and the increment calculated from the equation

$$\Delta e_d' = \frac{de_d'}{dt} \Delta t \quad (70)$$

A shunt resistance-reactance load such as an induction motor is not much more difficult to solve numerically but the expressions become too involved for analytical solution. It is necessary only to calculate i_d in terms of e_d' and θ just as was done before and then follow the same steps as used for the reactance load.

22. Unsaturated Machine Connected to Resistance-Reactance Load

A case not too laborious to carry through analytically is that for which a resistance-reactance load is suddenly applied to a synchronous machine. Let r_{ext} and x_{ext} be the external resistance and reactance. The addition of a subscript l to machine constants indicates the addition of r_{ext} or x_{ext} to the respective quantity. The equations of Sec. 17 then apply to this case, if e_t in the equations is made equal to zero and x_d replaced by x_{dl} , etc.

Following the same procedure as previously, there results from Eq. (48) when e_d and x_d are replaced by e_d' and x_{dl} and e_t is equal to zero.

$$i_d = \frac{x_{qt}}{r_t^2 + x_{dl}^2 x_{qt}} e_d' \quad (71)$$

The field current or its equivalent, the synchronous internal voltage, is then

$$\begin{aligned} e_d &= e_d' + (x_{dl} - x_{dl}') i_d \\ &= e_d' + (x_{dl} - x_{dl}') \frac{x_{qt}}{r_t^2 + x_{dl}^2 x_{qt}} e_d' \\ &= \frac{x_{dl} x_{qt} + r_t^2}{x_{dl}^2 x_{qt} + r_t^2} e_d' \end{aligned} \quad (72)$$

Substituting this expression in (52) there results that

$$e_x = \frac{x_{dl} x_{qt} + r_t^2}{x_{dl}^2 x_{qt} + r_t^2} e_d' + T_{do}' \frac{de_d'}{dt} \quad (73)$$

which can be converted to

$$\frac{T_d'}{T_{do}'} e_x = e_d' + T_d' \frac{de_d'}{dt} \quad (74)$$

in which

$$T_d' = \frac{x_{dl}^2 x_{qt} + r_t^2}{x_{dl} x_{qt} + r_t^2} T_{do}' \quad (75)$$

From this point the follow-up method can be used as before. After e_d' is determined as a function of time any other quantity such as terminal voltage can be obtained readily.

23. Saturation

In analyzing transient phenomenon of machines in the unsaturated condition, the theory was built around the concept of the transient internal voltage, e_d' , a quantity evaluated by using the transient reactance, x_d' . In the presence of saturation it was found that for steady-state conditions by the introduction of the Potier reactance, x_p (see Sec. 3) the proper regulation was obtained at full load zero power-factor. The use of x_p and e_p also resulted in satisfactory regulation for other power-factors. In extending the analysis into the realm of transient phenomenon, e_p will continue to be used as a base from which to introduce additional mmf into the field circuit to take care of saturation effects. The treatment will follow quite closely the same assumptions as were used in determining the steady-state regulation according to the Two-Reaction Potier Voltage method of Sec. 3(d).

With this assumption the fundamental Eq. (52) for the field circuit becomes

$$e_x = e_d + (s \text{ due to } e_p) + T_{do}' \frac{de_d'}{dt} \quad (76)$$

As before e_d represents, neglecting saturation, the voltage behind the synchronous reactance of the machine or what is equivalent the field current required to produce the instantaneous e_d' , including the demagnetizing effect of the instantaneous armature current. The total field current is obtained by adding s to e_d . In some cases it is found simpler to convert all of the right hand side to the single variable e_p but in others it is simpler to retain the variable in the form of e_d' . Two applications of this equation will be discussed.

Machine Connected to Infinite Bus—The circuit shown in Fig. 35(a) is the one under discussion and for which Eq. (66) applies for the unsaturated condition. This equation can be expanded to include saturation, in accordance with Eq. (76), to the following

$$\begin{aligned} e_x &= \frac{x_s x_o + x_d x_s + x_d x_o}{x_s x_o + x_d' x_s + x_d' x_o} e_d' - \frac{x_s(x_d - x_d')}{x_s x_o + x_d' x_s + x_d' x_o} E \cos \theta \\ &\quad + (s \text{ due to } e_p) + T_{do}' \frac{de_d'}{dt}. \end{aligned} \quad (77)$$

This can be converted to

$$\frac{de_d'}{dt} = \frac{e_x - (s \text{ due to } e_p)}{T_{do}'} + \frac{x_s(x_d - x_d') E \cos \theta}{(x_s x_o + x_d x_s + x_d x_o) T_d'} - \frac{e_d'}{T_d'} \quad (78)$$

in which T_d' is defined from Eq. (68). Before (78) can be used it will be necessary to determine e_p in terms of e_d' .

The components of current, i_q and i_d , can be determined from (39) and (40) by replacing e_d by e_d' and x_d by x_d' . Thus

$$i_q = \frac{x_s E \sin \theta}{x_s x_o + x_q x_s + x_q x_o} \quad (79)$$

$$i_d = \frac{(x_s + x_o) e_d' - x_s E \cos \theta}{x_s x_o + x_d' x_s + x_d' x_o} \quad (80)$$

The direct-axis component of e_p is equal to

$$e_{pd} = e_d' - (x_d' - x_p)i_d \\ = \frac{x_s x_c + x_p x_s + x_p x_c}{x_s x_c + x_d' x_s + x_d' x_c} e_d' + \frac{x_s (x_d' - x_p) E \cos \theta}{x_s x_c + x_d' x_s + x_d' x_c} \quad (81)$$

and the quadrature-axis component of e_p is

$$e_{pq} = (x_q - x_p)i_q \\ = \frac{x_s (x_q - x_p) E \sin \theta}{x_s x_c + x_q x_s + x_q x_c} \quad (82)$$

The amplitude of e_p is then equal to

$$e_p = \sqrt{e_{pd}^2 + e_{pq}^2} \quad (83)$$

While this quantity does not simplify greatly, it does not appear so formidable after numerical values are inserted. e_p can thus be calculated for any instantaneous value of e_d' and the s corresponding thereto substituted in Eq. (78). Equation (73) provides a means for computing increments of change in e_d' for use in step-by-step solution. Thus

$$\Delta e_d' = \frac{de_d'}{dt} \Delta t \quad (84)$$

As s becomes small and saturation effects disappear, the solution relapses into the same type as used when saturation is negligible (Eq. 66), for which the follow-up method is frequently applicable.

The relations just developed are useful in estimating the extent to which e_d' varies in system stability problems. Fig. 42 shows the results of calculations on a system in which a generator is connected to a large network, represented as an infinite bus, through a reactance equal to $j0.6$.

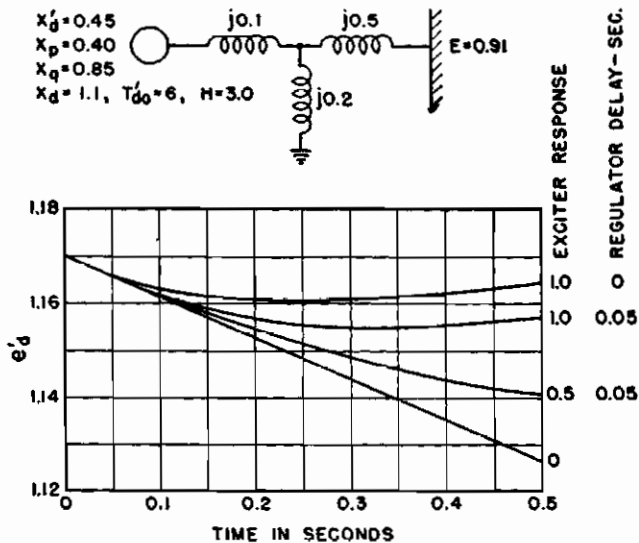

Fig. 42—Effect of rate of response upon e_d' as a line-to-line fault represented by the three-phase shunt load $j0.2$ is applied to generator which had been operating at 90 percent power-factor. 20 percent of air-gap mmf required for iron at rated voltage.

A line-to-line fault is assumed applied to the connecting transmission line on the high tension bus at the generating end which is equivalent to a three-phase short circuit through a reactance of $j0.2$ ohms. The curves justify the

assumption that is usually made in stability studies that where quick response excitation is installed, e_d' may be regarded as constant.

Machine Connected to Resistance-Reactance Load—This case is the same as that considered in Sec. 22 except that saturation effects are to be included. Upon including the saturation term s into Eq. (74) there results that

$$\frac{T_d'}{T_{d0}'} \left[e_x - (s \text{ due to } e_p) \right] = e_d' + T_d' \frac{de_d'}{dt} \quad (85)$$

in which

$$T_d' = \frac{x_d' x_{qt} + r_t^2}{x_d' x_{qt} + r_t^2} T_{d0}' \quad (86)$$

It is well to recall again that this analysis neglects sub-transient effects and assumes that the time constant in the quadrature axis is zero. If in Eqs. (48) and (49) e_t is made equal to zero, e_d is replaced by e_d' and the corresponding changes in reactance associated with e_d' are made, and in addition the subscripts are changed to indicate total reactances, Then

$$i_d = \frac{x_{qt}}{x_d' x_{qt} + r_t^2} e_d' \quad (87)$$

$$i_q = \frac{r_t}{x_d' x_{qt} + r_t^2} e_d' \quad (88)$$

The total current is then

$$i = \frac{\sqrt{x_{qt}^2 + r_t^2}}{x_d' x_{qt} + r_t^2} e_d' \quad (89)$$

The voltage e_p is

$$e_p = i \sqrt{x_p^2 + r_t^2} \\ = \frac{\sqrt{(x_{qt}^2 + r_t^2)(x_{qt}^2 + r_t^2)}}{x_d' x_{qt} + r_t^2} e_d' \quad (90)$$

Upon substituting e_d' from (90) into (85) and using (86) also there results that

$$\frac{\sqrt{(x_{qt}^2 + r_t^2)(x_{qt}^2 + r_t^2)}}{x_d' x_{qt} + r_t^2} e_x - \frac{\sqrt{(x_{qt}^2 + r_t^2)(x_{qt}^2 + r_t^2)}}{x_d' x_{qt} + r_t^2} (s \text{ due to } e_p) \\ = e_p + T_d' \frac{de_p}{dt} \quad (91)$$

As can be seen from Fig. 43 the solution of this equation lends itself well to the follow-up method. On the right-hand side the assumed exciter response curve, e_x , is plotted as a function of time. Multiplying this quantity by the coefficient of e_x , the term $e_{p\infty}$ is obtained. This is the value e_p tends to attain if there were no saturation effects. As in the follow-up method, the zero of time from which the instantaneous curve of e_p is drawn, is displaced to the left an amount T_d' minus half the interval of time chosen in the step-by-step solution. Along the ordinate of e_p a curve s_1 equal to the second term is plotted in which s is obtained from the no-load saturation curve shown in (b). For any instantaneous value of e_p , s_1 is plotted downward from $e_{p\infty}$ as the construction progresses. So starting from the initial value of e_p , of which more will be said later, a construction line is drawn to a point for which s_1 is the value corresponding to the initial value of e_p . For the second interval

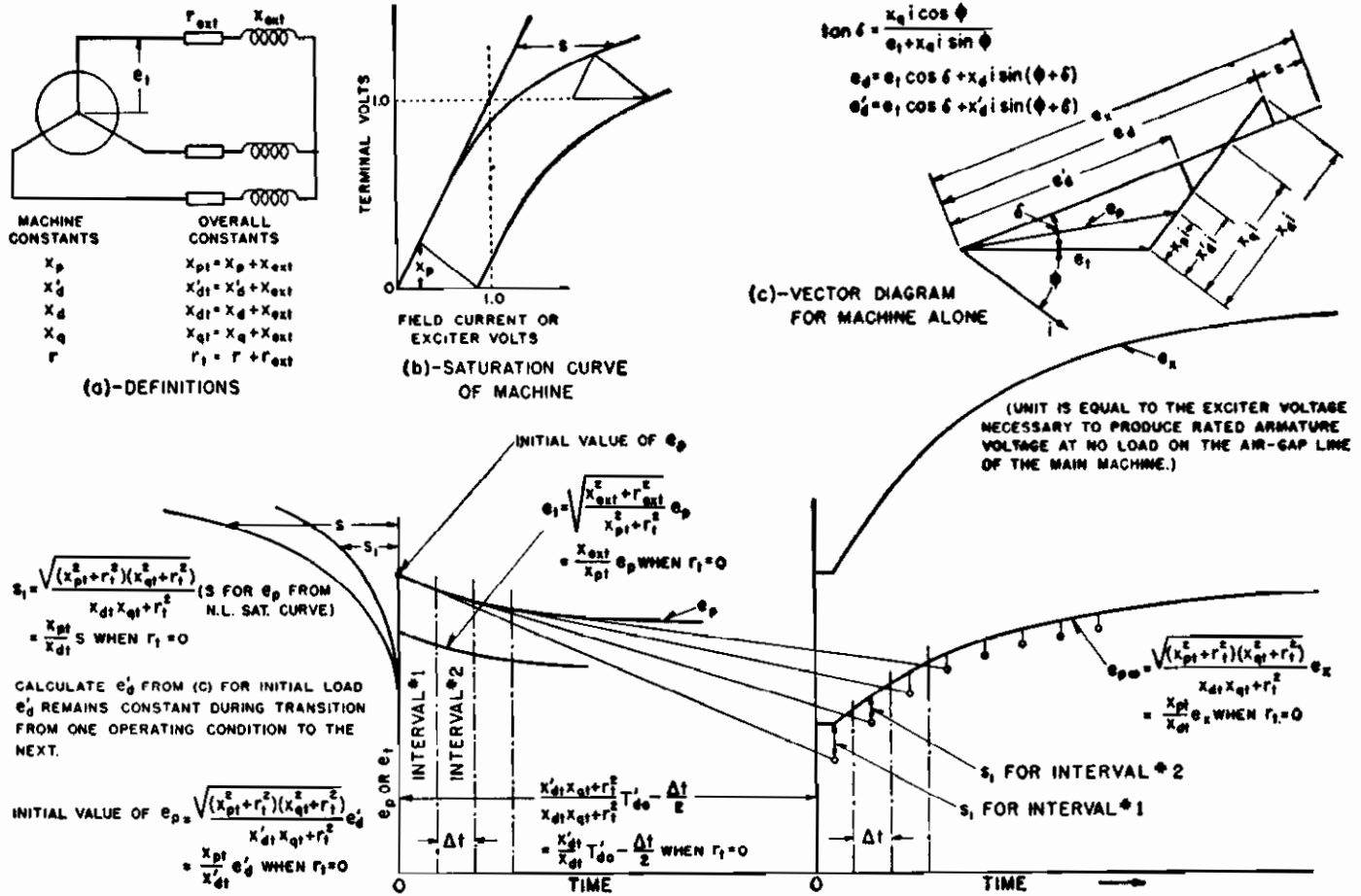

Fig. 43—Graphical determination of terminal voltage as polyphase series resistances, r_{ext} and reactances x_{ext} are suddenly applied.

s_1 is taken for the value of e_p at the end of the first interval or, to be slightly more accurate for an estimated average value of e_p for the second interval. And so the construction proceeds.

By the same reasoning whereby e_p was obtained in Eq. (90) the terminal voltage e_t can likewise be obtained, giving

$$e_t = i \sqrt{x_{ext}^2 + r_{ext}^2} = \frac{\sqrt{(x_{qt}^2 + r_t^2)(x_{ext}^2 + r_{ext}^2)}}{x_d i x_{qt} + r_t^2} e'_d$$

and substituting e'_d from (90)

$$e_t = \sqrt{\frac{x_{ext}^2 + r_{ext}^2}{x_{pt}^2 + r_t^2}} e_p \tag{92}$$

This permits of the calculation of e_t from e_p after the construction has been completed.

During the transition from one operating condition to the next, only e'_d remains constant; e_p changes. It is essential therefore that e'_d be computed for the initial operating condition. The conventional construction shown in Fig. 43(c) can be used. This determines the initial value of e'_d for the new operating condition from which the initial value of e_p can be computed by Eq. (90).

Common cases for which these calculations apply are the determination of regulation for loads suddenly applied to a generator. Instances in which this can occur are the

sudden disconnection of a loaded generator from the bus throwing its load upon the remaining units or the starting of an induction motor by direct connection to a generator. For the latter case, if the capacity of the induction motor is a significant fraction of the kva of the generator, a severe drop in voltage results. Thus a 500-hp motor thrown on a 3300-kva generator produces an instantaneous drop in voltage of the order of 13 percent. The effective impedance of the induction motor varies with slip and to be rigorous this variation should be taken into consideration. It is usually sufficiently accurate to use the blocked rotor reactance for the motor impedance up to the speed corresponding to maximum torque in calculating the factor which determines $e_{p\infty}$ in terms of e_x . Beyond the slip corresponding to maximum torque, the effective impedance varies rapidly to the running impedance. Simultaneously with the increase in impedance the lagging kva likewise drops off which results in a considerable rise in voltage. This effect is clearly shown in Fig. 44 taken from some tests made by Anderson and Monteith.²⁰ As running speed is approached the generator voltage rises, the excitation being too high for the particular loading. To form a better idea of the magnitudes involved in such calculations, Fig. 45 shows curves of terminal voltage as an induction motor equal in horse power to 20 percent of the kva of a generator is suddenly thrown upon an unloaded generator for differ-

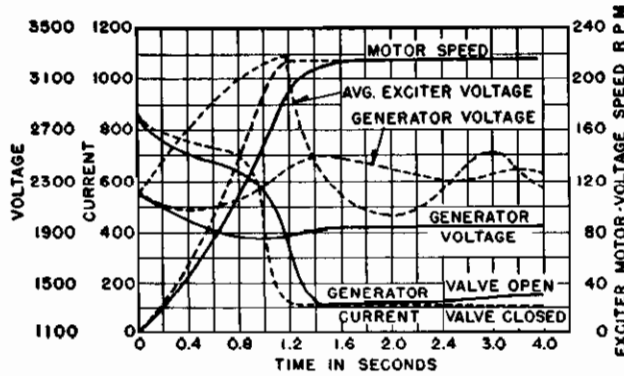

Fig. 44—Performance of 3333 kva, 0.6 power-factor, 3600 rpm, 1.7 short-circuit ratio generator as a single 500-hp induction-motor pump is started. Induction-motor starting torque equal to full-load torque and pull-out torque equal to 2.8 full-load torque. Full lines represent operation with fixed excitation and dotted lines under regulator control.

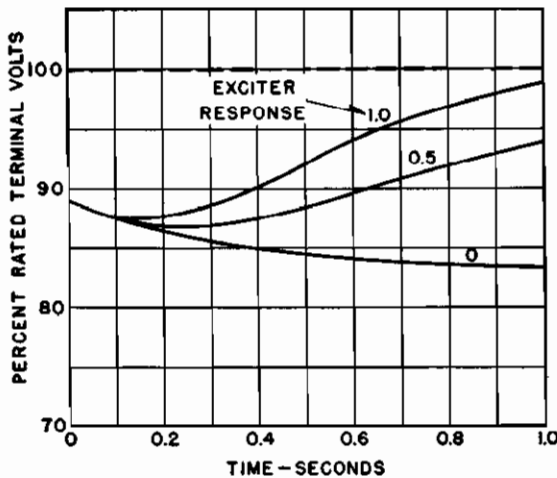

Fig. 45—Terminal voltage of a 500 kva, 80-percent power-factor engine-type generator ($x_d = 1.16$, $x_q = 0.59$, $x_d' = 0.30$, 13 percent saturation) as a 100-hp induction motor is connected.

ent rates of response of the exciter. Ordinarily one is primarily interested in the minimum voltage attained during the accelerating period and so the calculations have been carried out to only 1.0 second. The curves show conditions for constant excitation and for exciters with 0.5 and 1.0 ratios, respectively.

24. Drop in Terminal Voltage with Suddenly-Applied Loads

When a relatively large motor is connected to a generator, the terminal voltage may decrease to such an extent as to cause undervoltage release devices to operate or to stall the motor. This situation arises particularly in connection with the starting of large motors on power-house auxiliary generators. The best single criterion to describe this effect when the generator is equipped with a regulator to control the excitation is the maximum drop. The previous section describes a method whereby this quantity can be calculated. However, the problem arises so frequently that Harder and Cheek^{22,23} have analyzed the

problem generally and have plotted the results in curve form.

The analysis has been carried out for both self-excited and separately-excited exciters. The results for the former are plotted in Fig. 46, and for the latter in Fig. 47. These curves are plotted in terms of the four parameters: (1) magnitude of load change (2) $X'_{d\text{sat}}$ (3) T'_{d0} , and (4) rate of exciter response, R . The response is defined in the chapter on Excitation Systems. It is shown by Harder and Cheek²² that variations in x_d , saturation factor of the generator and power factor between zero and 60 percent have little effect upon the maximum drop. The assumed value of x_d for these calculations was 120 percent. An accurate figure for maximum voltage drop can be obtained for values of x_d other than 120 percent by first expressing reactances and the applied load on a new kva base, such that x_d on the new base is 120 percent, and then applying the curves. For example, suppose a load of 1500 kva (expressed at full voltage) of low power factor is to be applied to a 3000-kva generator having 30-percent transient reactance and 150-percent synchronous reactance. Suppose that the generator time constant is 4.0 seconds and the exciter has a nominal response of 1.0. To determine the drop, express the transient reactance and the applied load on the kilovolt-ampere base upon which x_d is 120 percent. The base in this case will be $3000 \times 120 / 150 = 2400$ kva. On this base the transient reactance x_d' is $30 \times 2400 / 3000 = 24$ percent, and the applied load is $1500 / 2400 = 62.5$ percent. If the exciter is self-excited then from the curves of Fig. 46, the maximum voltage drop is 15 percent for 62.5-percent load applied to a generator having 24-percent transient reactance, a time constant of 4.0 seconds, and an exciter of 1.0 nominal response. This same maximum drop would be obtained with the machine and load under consideration.

The initial load on a generator influences the voltage drop when additional load is suddenly applied. As shown in Fig. 48, a static or constant-impedance initial load reduces the voltage drop caused by suddenly applied load. However, a load that draws additional current as voltage decreases may increase the voltage drop. Such loads will be referred to as "dynamic" loads. For example, a running induction motor may drop slightly in speed during the voltage dip so that it actually draws an increased current and thereby increases the maximum voltage drop. The dynamic initial load curve of Fig. 48 is based on an initial load that draws constant kilowatts and power factor as the voltage varies.

VII. CONSTANTS FOR USE IN STABILITY PROBLEMS

The stability problem involves the study of the electro-mechanical oscillations inherent in power systems. A fundamental factor in this problem is the manner in which the power output of the generator varies as the position of its rotor changes with respect to some reference voltage. The natural period of power systems is about one second. Because of the series resistance external to the machine, the time constant of the unidirectional component of armature current is usually so small as to be negligible in

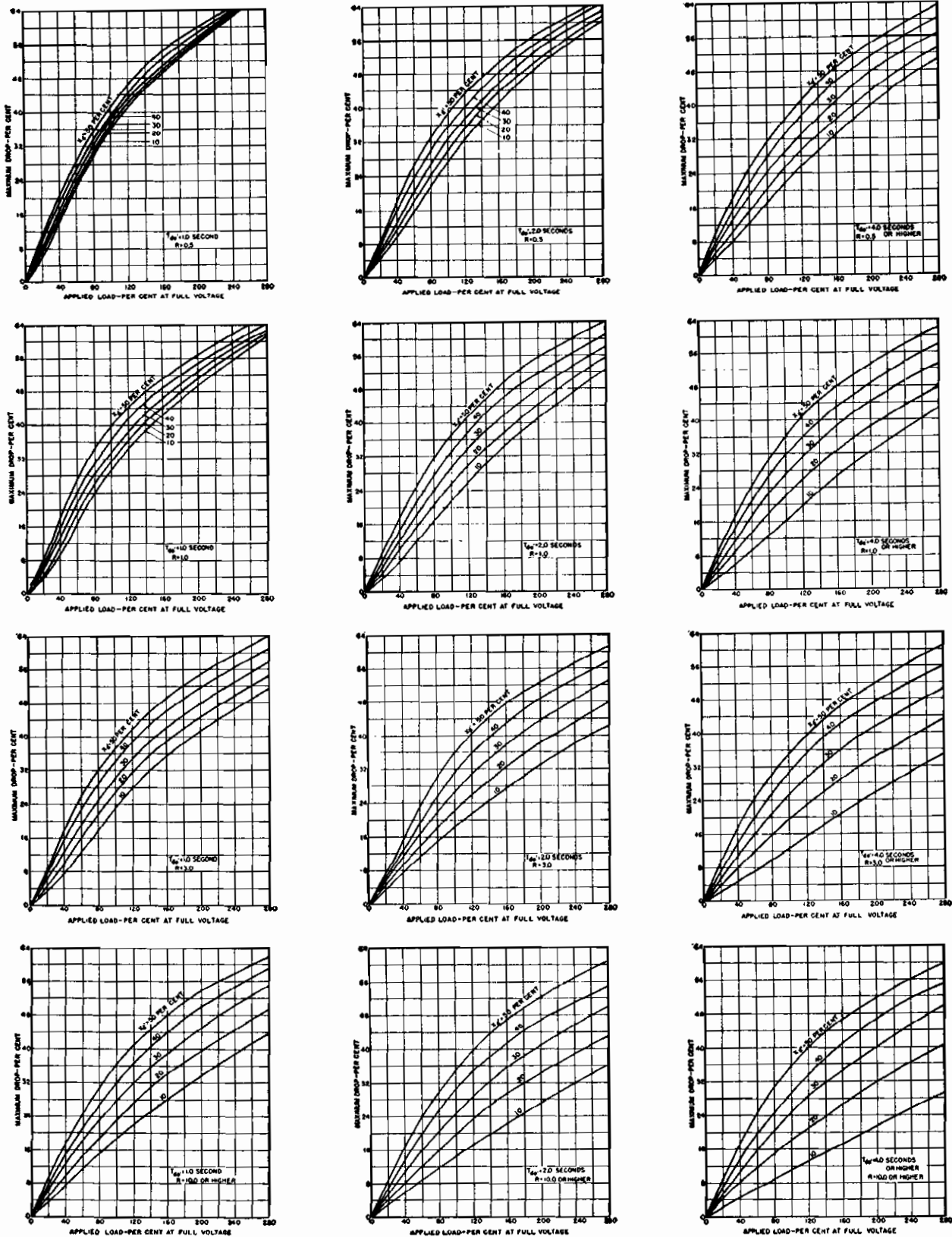

Fig. 46—Maximum voltage drop of a synchronous machine WITH SELF-EXCITED EXCITER as affected by (a) magnitude of load change, (b) x'_d sat, (c) T'_{do} and (d) rate of exciter response. x'_d on curves refer to saturated or rated-voltage value. Assumptions used in calculations: $x'_d = 1.07 x'_{d \text{ sat}}$; $x_d = 1.20$; $x_q = 0.75$; no-load saturation curve/air gap line normal voltage = 1.2; time lag of regulator = 0.05 second; added load is constant impedance of 0.35 pf.; initial load zero.

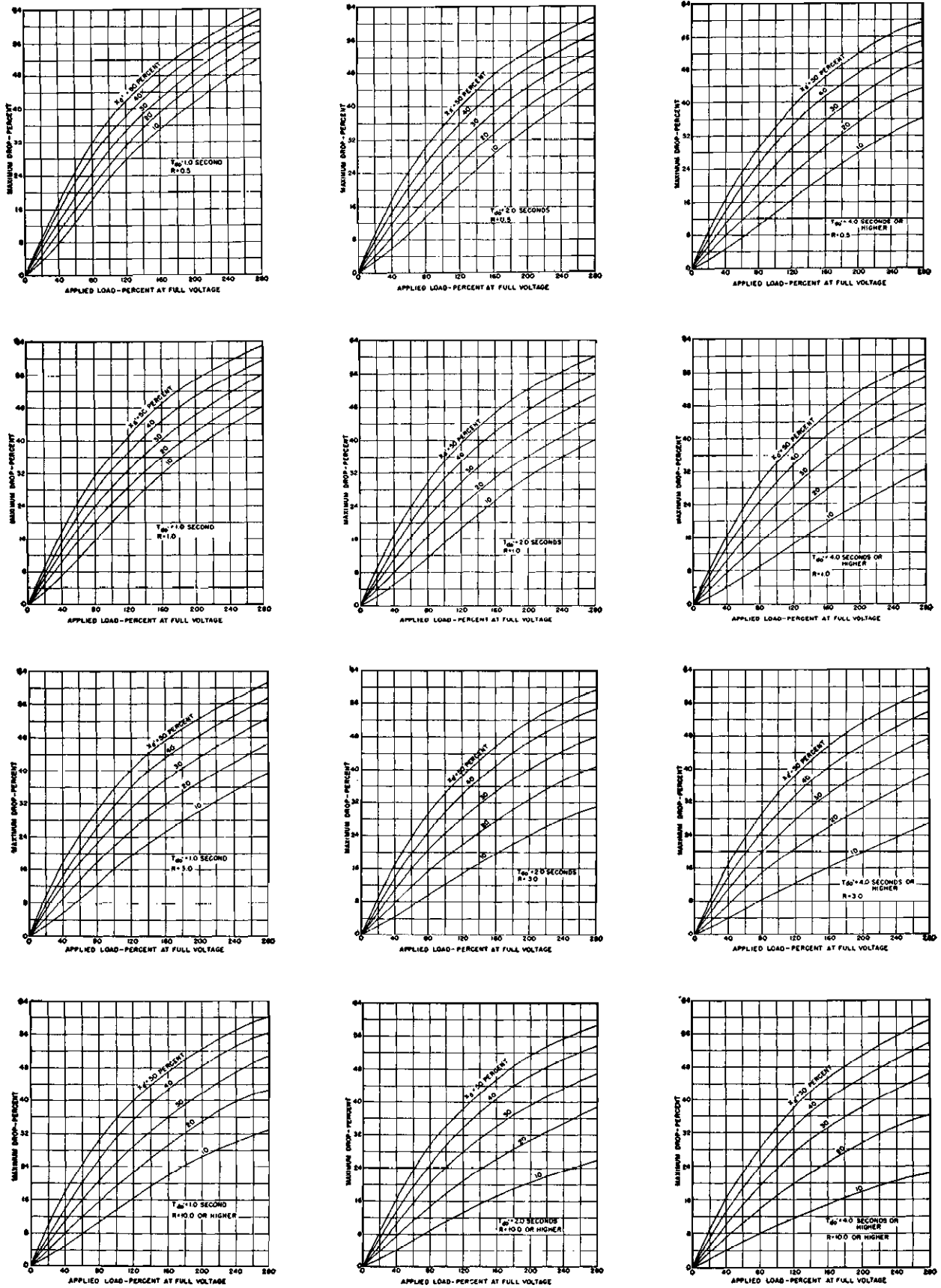

Fig. 47—Maximum voltage drop of a synchronous machine WITH SEPARATELY-EXCITED EXCITER as affected by (a) magnitude of load change, (b) $x'd_{\text{sat}}$, (c) T_{d0}' and (d) rate of exciter response.

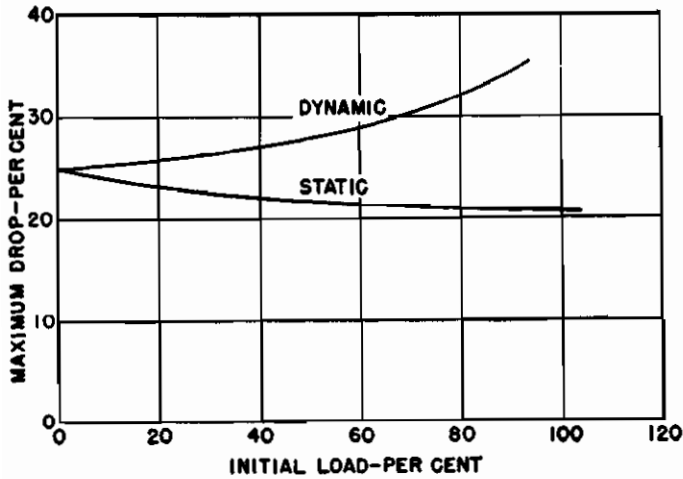

Fig. 48—Effect of type (whether dynamic or static) and initial load, assumed at 0.50 power factor, upon the maximum voltage drop when 100-percent low-power-factor load is suddenly applied to an a-c generator.

comparison with this natural period. The subtransient component is likewise so small that its effects can be neglected. There remains then only the transient components, those components associated with the time constants of the field winding, that are important.

25. Representation of Machine

The transient stability problem is primarily concerned with the power-angle relations during system swings following a disturbance. Because of the dissymmetry of the two axes, it is necessary theoretically to take this dissymmetry into consideration. However, in most cases an impedance is in series externally to the machine so that the difference in reactances in the two axes becomes a smaller proportion of the total reactance. The results of calculations presented in Chap. 13 show that for most practical purposes it is sufficiently accurate to represent the unsymmetrical machine with a symmetrical machine having the same x_d' .

In spite of the close agreement of salient-pole with cylindrical-rotor results, a few cases arise for which it is necessary to use salient-pole theory. Relations for calculating the power output have been given in Secs. 16 and 17 and for computing the change in internal voltages in Sec. 22(a). It is shown in the latter section that if the exciter is of the quick-response type, the voltage e_d' can, for all practical purposes, be regarded as constant. Methods for the inclusion of these factors into the stability calculations have also been treated in Chap. 13.

A knowledge of the inertia constant, H , is a requisite for the determination of the acceleration and deceleration of the rotor. It represents the stored energy per kva and can be computed from the moment of inertia and speed by the following expression

$$H = \frac{0.231 WR^2(\text{rpm})^2 10^{-6}}{\text{kva}} \tag{93}$$

where H = Inertia constant in kw-sec. per kva.
 WR^2 = Moment of inertia in lb-ft².

Further consideration of this constant is given in Part XIII of this chapter.

26. Network Calculator Studies

For most problems the synchronous machine can be represented by its transient reactance and a voltage equal to that behind transient reactance. For the rare case for which salient-pole theory is required, the following procedure can be followed. It is impossible to set up the two reactances in the two axes by a single reactor, but if the reactance, x_q , is used and a new voltage, e_{qd} , introduced as representing the internal voltage, both position of the rotor and the variations in e_d' can be carried through quite simply.

Fig. 49 shows a vector diagram similar to Fig. 14 in which e_{qd} is included. This voltage is laid off along e_d and e_d' and terminates at the point a . The reading of power at e_{qd} is the same as the actual output of the machine. As the exciter voltage changes e_d' and e_{qd} likewise change.

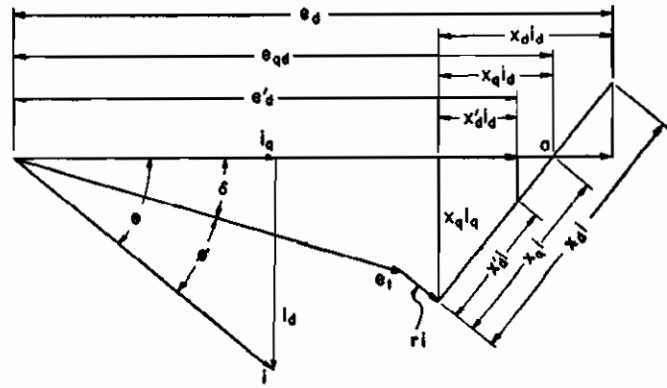

Fig. 49—Construction of e_{qd} for network calculator studies.

The incremental changes in e_{qd} can be obtained as follows. From Fig. 49 it is evident that at any instant

$$e_{qd} = e_d' + (x_q - x_d') i_d \tag{94}$$

From Eq. (52)

$$\frac{de_d'}{dt} = \frac{1}{T_{d0}'} (e_x - e_d)$$

and

$$\Delta e_d' = \frac{de_d'}{dt} \Delta t = \frac{1}{T_{d0}'} (e_x - e_d) \Delta t \tag{95}$$

where $\Delta e_d'$ is the increment of e_d' in the increment of time Δt . From Fig. 49 there results also that

$$e_d = e_{qd} + (x_d - x_q) i_d \tag{96}$$

so that

$$\Delta e_d' = \frac{1}{T_{d0}'} [e_x - e_{qd} - (x_d - x_q) i_d] \Delta t. \tag{97}$$

In network calculator studies of system stability, e_x , e_{qd} , and i_d are known at any instant. From Eq. (94) it is evident that the increment of e_{qd} is equal to the increment in e_d' . Thus

$$\Delta e_{qd} = \frac{1}{T_{d0}'} [e_x - e_{qd} - (x_d - x_q) i_d] \Delta t \tag{98}$$

This method can be applied regardless of the number of machines involved in the study.

To obtain the initial value of e_{qd} , calculate e_d' from the steady-state conditions before the disturbance. e_d' is the quantity which remains constant during the instant representing the change from one operating condition to another. The proper e_{qd} is obtained by changing the magnitude of e_{qd} until Eq. (94) is satisfied.

To include the effect of saturation, break the reactance x_q , which represents the machine, into two components x_p and $(x_q - x_p)$, the latter being next to the voltage e_{qd} . The voltage at the junction of these two reactances is e_p , the voltage behind x_p . The effect of saturation will be included by adding the saturation factor s taken from the no-load saturation curve (see Fig. 17) for e_p , to the excitation obtained by neglecting saturation. This corresponds to method (d) of Sec. 3 for steady-state conditions. Eq. (98) then becomes

$$\Delta e_{qd} = \frac{1}{T'_{do}} \left[e_x - e_{qd} - (x_d - x_q)i_d - s \right] \Delta t \quad (99)$$

27. Armature Resistance

For most stability studies the loss associated with the resistance of the armature is so small as to be negligible. The exception to this rule is the case for which a fault occurs near the terminals of a generator.

The losses in an a-c generator during a three-phase short circuit can be large enough to affect significantly the rate at which the rotor changes angular position. This is of particular importance for stability studies. Two of the most important factors determining this effect are the location of the fault and the value of the negative-sequence resistance. The latter is difficult of evaluation particularly for turbo-generators—the type of machine in which the effect is greatest. One must rely almost entirely upon calculations, which are extremely complicated. For a-c board studies of system stability it is convenient to represent the machine losses by means of a resistance placed in series in the armature. The value of this resistance should be chosen so that its loss, with the reactance of the machine represented by x_d' , be equivalent to that of the machine under actual conditions. An approximate evaluation of this equivalent resistance will be developed for a turbo-generator.

Let the initial value of the subtransient component of short-circuit current be designated, i'' . The components of the unidirectional current have a *maximum* value $\sqrt{2}i''$ and are related in the three phases in a manner as discussed in Sec. 8. The sum of the unidirectional components in all three phases produce an essentially sinusoidal wave of *mmf* that is stationary with respect to the armature. This stationary *mmf* develops a flux that in turn generates currents having a frequency of 60 cps in the rotor. This effect is similar to that produced by negative-sequence currents in the armature except that the latter produce a sinusoidal *mmf* wave that rotates at a speed corresponding to 60 cps in a direction opposite to the rotation of the shaft and ultimately generates circulating currents in the rotor having a frequency of 120 cps. The magnitudes of the *mmf* waves in the two cases are equal for the same *crest* values

of unidirectional and negative-sequence currents. The crest value of the negative-sequence current, i_2 , is $\sqrt{2}i_2$ and the crest value of i'' is $\frac{\sqrt{2}}{x_d''}$.

In the case of negative-sequence currents, part of the loss is supplied by the shaft and part is supplied through the armature. The loss associated with the circulating currents in the rotor as developed in Section 15 is *approximately* equal to $2(r_2 - r_1)i_2^2$. Assuming for the moment that the loss varies as the square of the current and neglecting the differences due to the frequencies in the two cases, the loss for the unidirectional components of current is

$$\left(\frac{\sqrt{2}}{x_d''} \right)^2 2(r_2 - r_1)i_2^2 \text{ or } \frac{2(r_2 - r_1)}{(x_d'')^2}$$

Actually, however, the loss varies more nearly as the 1.8 power of the current so that the expression becomes

$$\frac{2(r_2 - r_1)}{(x_d'')^{1.8}}$$

Now considering the effect of frequencies. Since the depth of current penetration varies inversely as the square root of the frequency, the resistance varies directly as the square root of the frequency. The loss for the unidirectional component is then

$$\frac{2(r_2 - r_1)}{\sqrt{2}(x_d'')^{1.8}} \text{ or } \frac{\sqrt{2}(r_2 - r_1)}{(x_d'')^{1.8}} \quad (101)$$

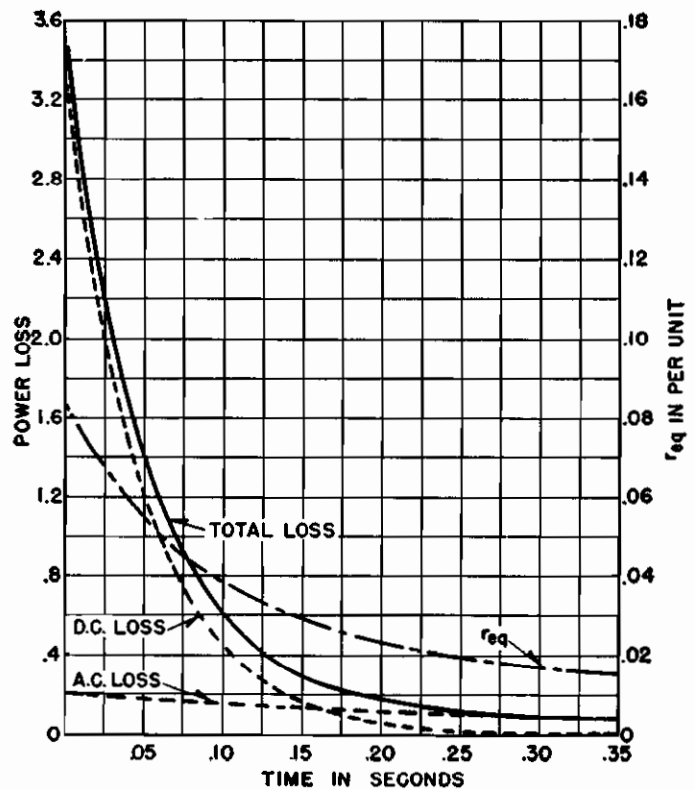

Fig. 50—Development of r_{eq} of a turbo-generator for the condition of a three-phase short circuit across the terminals of the machine for various duration of the short circuit.

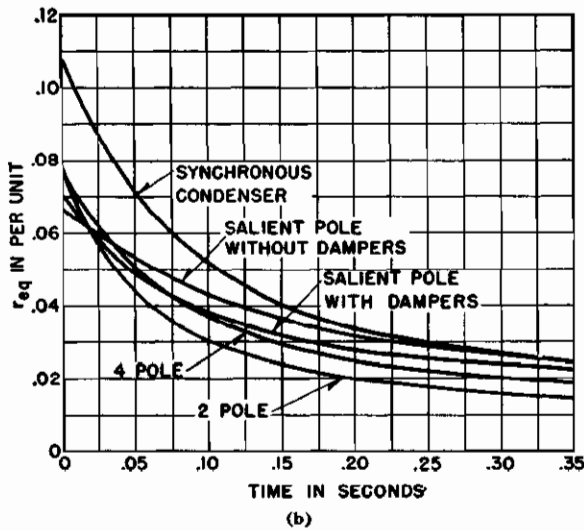
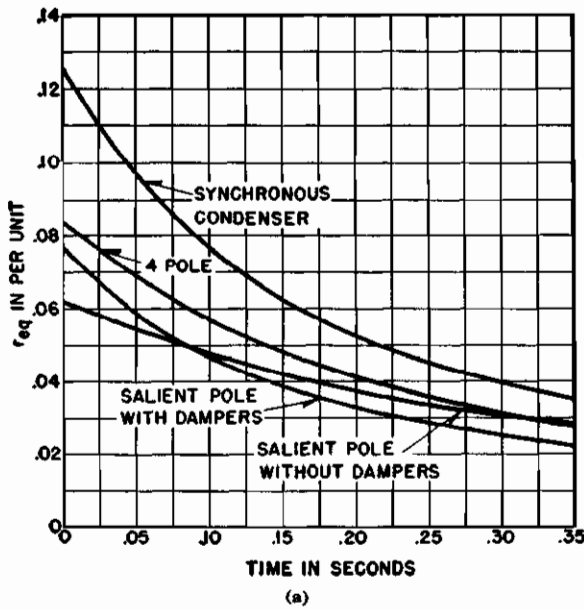

Fig. 51—Typical equivalent resistance, r_{eq} , for different types of machines.

- (a) for three-phase short circuit across the terminals used
- (b) for three-phase short circuit across the terminals of a series-connected transformer of 10 percent impedance.

Since the unidirectional current decreases exponentially with a time constant T_a , the loss as a function of time is

$$\frac{\sqrt{2}(r_2 - r_1) \epsilon^{-\frac{1.8t}{T_a}}}{(x_d'')^{1.8}} \quad (102)$$

In addition to the losses associated with the unidirectional current, the load losses as reflected by r_1 can also be significant for a three-phase fault across the terminals. Neglecting the sub-transient component, the a-c component of short-circuit for a three-phase short circuit from no-load is

$$\left[\left(\frac{1}{x_d'} - \frac{1}{x_d} \right) \epsilon^{-\frac{t}{T_d'} + \frac{1}{x_d}} \right] \quad (103)$$

The loss associated with this current is

$$r_1 \left[\left(\frac{1}{x_d'} - \frac{1}{x_d} \right) \epsilon^{-\frac{t}{T_d'} + \frac{1}{x_d}} \right]^2 \quad (104)$$

To form an idea of the order of magnitudes of these losses, let

$$\begin{aligned} x_d'' &= 0.09. & T_a &= 0.09. \\ x_d' &= 0.15. & T_d' &= 0.6. \\ x_d &= 1.25. \\ r_2 &= 0.035. \\ r_1 &= 0.005. \end{aligned}$$

The results of the calculations are shown in Fig. 50. The upper dashed curve is the loss associated with the unidirectional component and the lower dashed curve the load losses. The full line represents the total losses. The current flowing in the generator as represented on the board is constant and equal to $\frac{1}{x_d}$. The equivalent resistance, r_{eq} , to be inserted in series with x_d' must be such that the integrated loss over any interval must be the same as that in Fig. 50. The dot-dash curve in Fig. 50 gives the values of r_{eq} obtained by this method.

Figure 51 gives similar values of r_{eq} for other types of machines. The curves in Fig. 51(a) were calculated for short circuits at the terminals of the machines, those in Fig. 51(b) are for three-phase short circuits across the terminals of a transformer connected in series with the machine.

VIII. UNBALANCED SHORT CIRCUITS ON MACHINES WITHOUT DAMPER WINDINGS

Because of the dissymmetry of salient-pole machines without damper windings, the armature currents at times of three-phase short-circuits, as shown in Sec. 12, contain second-harmonic components. For unsymmetrical short-circuits, such as from terminal-to-terminal, the wave forms of currents and voltages become even more complex. Both odd and even harmonics are present.

28. Terminal-to-Terminal Short Circuit

In particular consider a salient-pole machine in which saturation is neglected and which is operating at no load to which a short-circuit is suddenly applied across two terminals. The short-circuit current⁵ in these phases is then

$$i = \frac{\sqrt{3} I_t [\sin(2\pi ft + \phi_0) - \sin \phi_0]}{(x_q + x_d') + (x_q - x_d') \cos 2(2\pi ft + \phi_0)} \quad (105)$$

in which ϕ_0 indicates the phase position during the cycle at which the short-circuit occurred.

It will be observed that this can be resolved into two components

$$\text{First: } \frac{\sqrt{3} I_t \sin(2\pi ft + \phi_0)}{(x_q + x_d') + (x_q - x_d') \cos 2(2\pi ft + \phi_0)} \quad (106)$$

$$\text{Second: } \frac{\sqrt{3} I_t \sin \phi_0}{(x_q + x_d') + (x_q - x_d') \cos 2(2\pi ft + \phi_0)} \quad (107)$$

The first component is shown in Fig. 52(a) for a typical machine and consists of odd harmonics only. The second

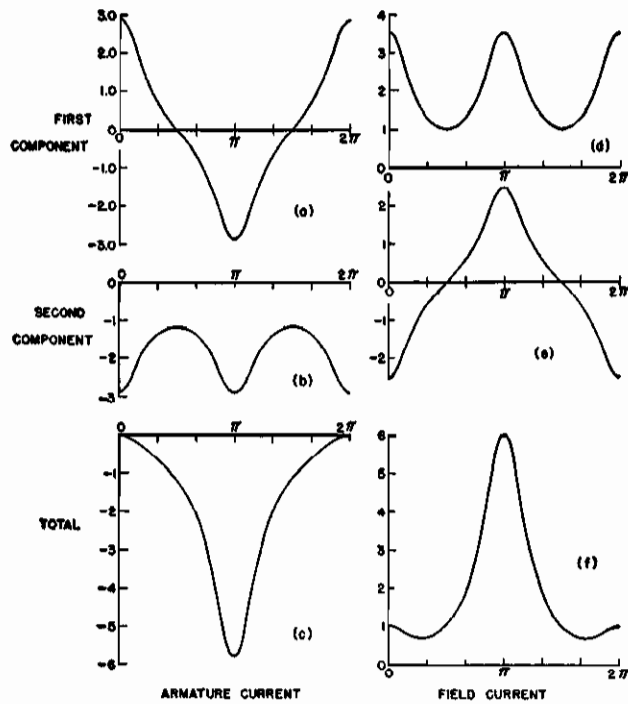

Fig. 52—Armature current and field current in a synchronous machine when a terminal-to-terminal short circuit is suddenly applied.

$$x_d' = 0.30 \quad x_d = 1.1 \quad x_q = 0.75 \quad \phi_0 = 90^\circ$$

component is shown in Fig. 52(b) for $\phi_0 = +90^\circ$ and consists of even harmonics only. The latter component is dependent upon the instant during the cycle at which the short-circuit occurs and may vary anywhere between the values given and the negative of those values in accordance with the coefficient, $\sin \phi_0$. Figure 52(c) gives the total current, the sum of Figs. 52(a) and 52(b).

The units chosen are the p.u. in which for the machine operating at no-load at rated circuit voltage I_t would be equal to 1.0 and in this case the current i is given in terms of crest magnitude of rated phase current.

The components of armature current shown in Figs. 52(a) and 52(b) have associated with them the field currents shown in Figs. 52(d) and 52(e), respectively, the former consisting only of even harmonics and the latter only of odd harmonics. In Fig. 52(f) is shown the total field current. The average magnitude of this current is equal to

$$\frac{x_d + \sqrt{x_q x_d'}}{x_d' + \sqrt{x_q x_d'}} I_t$$

The odd-harmonic component of field current and its associated even harmonic in the armature decay to zero with time. The even harmonics of the field and their associated odd harmonics of armature current decay to constant, steady-state amounts. Their initial values are in excess of their steady-state magnitudes by the amount the average of I_t is in excess of its steady-state amount, I_t . The steady-state value of i is then equal to the initial amount of the odd-harmonic component multiplied by

$$\frac{x_d' + \sqrt{x_q x_d'}}{x_d + \sqrt{x_q x_d'}}$$

$$\text{Thus } i_{\text{steady-state}} = \frac{\sqrt{3} I_t \frac{x_d' + \sqrt{x_q x_d'}}{x_d + \sqrt{x_q x_d'}} \sin(2\pi ft + \phi_0)}{[(x_q + x_d') + (x_q - x_d') \cos 2(2\pi ft - \phi)]} \quad (108)$$

With the assistance of Fig. 52 it will be seen from Eq. (105) that the maximum amount of the odd harmonic component is equal to $\frac{\sqrt{3} I_t}{2x_d'}$. The maximum value of the total current is dependent upon the instant during the cycle at which short-circuit occurs and reaches a maximum of $\frac{\sqrt{3} I_t}{x_d'}$.

Assuming no decrement for either the odd or even harmonics

$$i_{\text{rms (even)}} = \frac{\sqrt{3}}{2} \frac{I_t \sin \phi_0}{\sqrt{x_q x_d'}} \frac{\sqrt{1+b^2}}{\sqrt{1-b^2}} \quad (109)$$

$$i_{\text{rms (odd)}} = \sqrt{3} \frac{I_t}{x_d' + \sqrt{x_q x_d'}} \frac{1}{\sqrt{1-b^2}} \quad (110)$$

$$b = -\frac{\sqrt{x_q/x_d'} - 1}{\sqrt{x_q/x_d'} + 1} \quad (111)$$

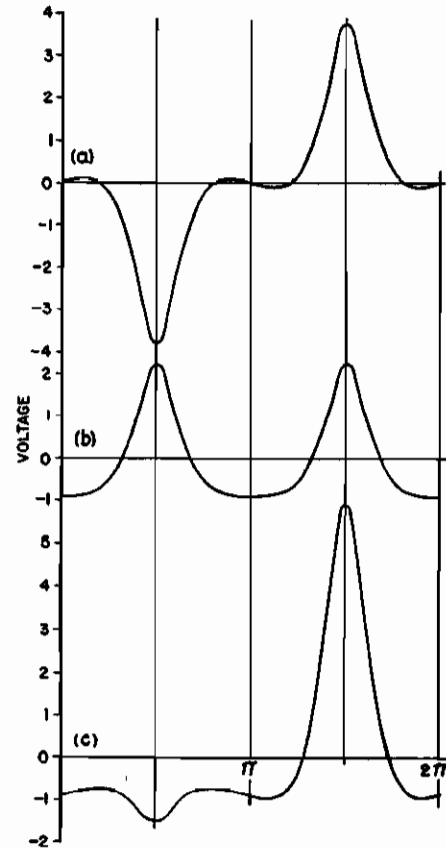

Fig. 53—Wave form of voltage across terminals of a water-wheel generator without damper windings for a terminal-to-terminal short circuit from no-load. $x_q/x_d' = 2.5$.

- (a) Initial value of odd harmonic component (decays slowly);
- (b) initial value of even harmonic component for $\sin \phi_0 = 1$ (decays rapidly). Its magnitude varies between that given and its negative depending upon the point during the cycle at which short circuit occurs. It may be zero.
- (c) Total initial value for $\sin \phi_0 = 1$

The rms total current is equal to the square root of the sum of the squares of those components. It must be remembered that the unit of current is the *crest of rated terminal current*. When expressed in terms of the *rated rms current* the above figures must be multiplied by $\sqrt{2}$.

The voltage from the short-circuited terminals to the free terminal, neglecting decrements, is equal to

$$e_a - e_b = e_{ab} = -3I_t K [\sin(2\pi ft + \phi_0) + 3b \sin 3(2\pi ft + \phi_0) + 5b^2 \sin 5(2\pi ft + \phi_0) + \dots] + 3I_t \sin \alpha [2b \cos 2(2\pi ft + \phi_0) + 4b^2 \cos 4(2\pi ft + \phi_0) + \dots] \quad (112)$$

in which

$$K = \frac{\sqrt{x_q/x_d'}}{\sqrt{x_q/x_d' + 1}} \quad (113)$$

and b has its previous significance.

Like the short-circuit current this voltage can likewise be resolved into two components that together with the total voltage are plotted in Fig. 53. The maximum possible voltage, that which occurs when $\sin \phi_0$ is equal to unity, is

$$e_{ab(\text{maximum for max. flux linkages})} = \frac{3}{2} I_t \left(2 \frac{x_q}{x_d'} - 1 \right) \quad (114)$$

When $\sin \phi_0 = 0$, the even harmonic component is equal to zero and for this case the maximum voltage is

$$e_{ab(\text{maximum for minimum flux linkages})} = \frac{3}{2} I_t \frac{x_q}{x_d'} \quad (115)$$

The corresponding line-to-neutral voltages for the terminal-to-terminal short-circuit are $\frac{2}{3}$ of the above figures. In all of these expressions the *crest* value of rated line-to-neutral voltage has been used as a base. When the *rms* figure is used, the above quantity must be multiplied by $\sqrt{2}$.

For a terminal-to-neutral short circuit, neglecting decrements, the short-circuit current is

$$i = \frac{3I_t [\cos(2\pi ft + \phi_0) - \cos \phi_0]}{(x_d' + x_q + x_0) + (x_d' - x_q) \cos 2(2\pi ft + \phi_0)} \quad (116)$$

29. Unsymmetrical Short Circuits Under Capacitive Loading

When a salient-pole machine without damper windings is loaded by a highly capacitive load,^{12, 13} there is danger,

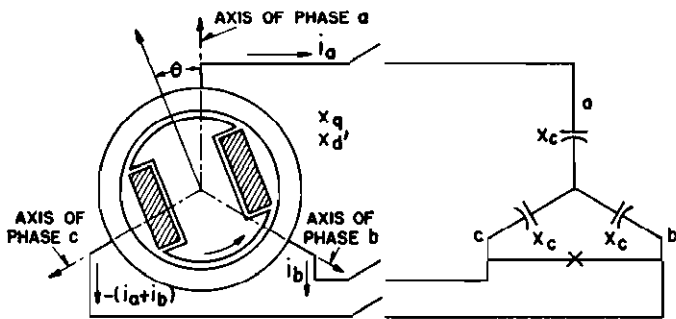

Fig. 54—Schematic diagram of a three-phase, salient-pole alternator to which a three-phase bank of capacitors and a terminal-to-terminal short circuit are applied simultaneously.

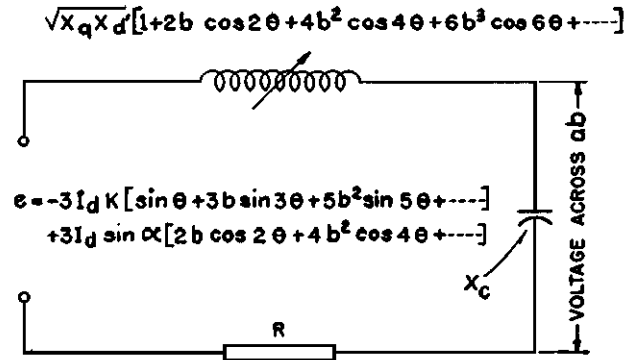

Fig. 55—Equivalent circuit to which Fig. 54 may be reduced.

$$b = \frac{\sqrt{x_q/x_d'} - 1}{\sqrt{x_q/x_d'} + 1} \quad k = \frac{\sqrt{x_q/x_d'}}{\sqrt{x_q/x_d'} + 1}$$

at times of unbalanced short circuit, that resonance occur between the reactance of the machine and the load with the possibility that dangerously high voltages might result. Considering a purely capacitive load such as an unloaded transmission line, the schematic diagram is shown in Fig. 54 and the equivalent circuit in Fig. 55 for the condition of a terminal-to-terminal short circuit. The emf applied to the circuit is equal to the open-circuit voltage for the same short-circuit condition. The oscillographic results of tests made on a particular machine as terminal-to-terminal short circuits are applied for different amounts of connected capacitance are shown in Fig. 56. Resonance

will occur near points for which the quantity $\frac{x_c}{\sqrt{x_d' x_q}} = n^2$, where n represents the integers 1, 2, 3, etc., and also the order of the harmonic. The nature of this resonance phenomenon is illustrated more clearly by the curve of Fig. 57, in which is plotted the maximum voltage during short-circuit in per unit.

To orient one's self with regard to the length of line involved in these considerations, the figure in miles which appears below each oscillogram of Fig. 56 represents approximately the length of single-circuit 66- or 220-kv transmission line that, with a generator having the characteristics of the one used in the test, is required to satisfy the given value of $x_c/\sqrt{x_d' x_q}$. These figures were arrived at by assuming a generator capacity of 25 000, 75 000, and 200 000 kva for 66-, 132-, and 220-kv lines, respectively. For smaller machines the length will decrease in proportion.

The possibility of the existence of such resonant conditions can be determined for other types of loads and other types of faults by setting up the network for the system and replacing the machine by the reactance $\sqrt{x_q x_d'}$. This circuit should be set up for the positive-, negative-, and zero-sequence networks and the networks connected in accordance with the rules of symmetrical components. Any condition for which the impedance as viewed from the machine is zero or very small should be avoided.

Since the danger of these high voltages arises from the dissymmetry of the machines, it can be eliminated effectively by the installation of damper windings. Fig. 58 presents oscillographic evidence of the voltages existing for machines equipped with different types of dampers as

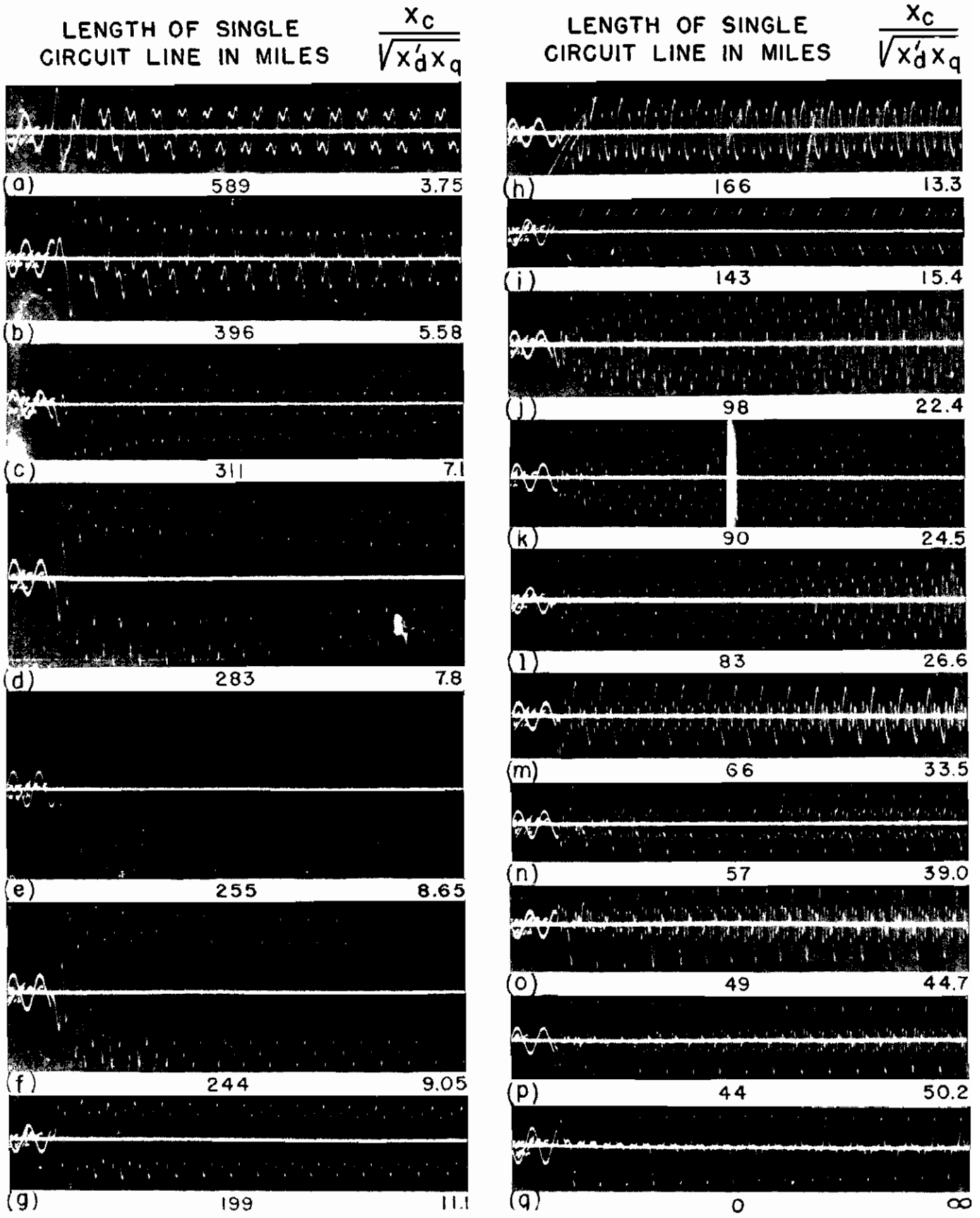

Fig. 56—Effect upon the terminal voltage of varying the shunt capacitive reactance when a terminal-to-terminal short circuit is applied to a machine without damper windings.

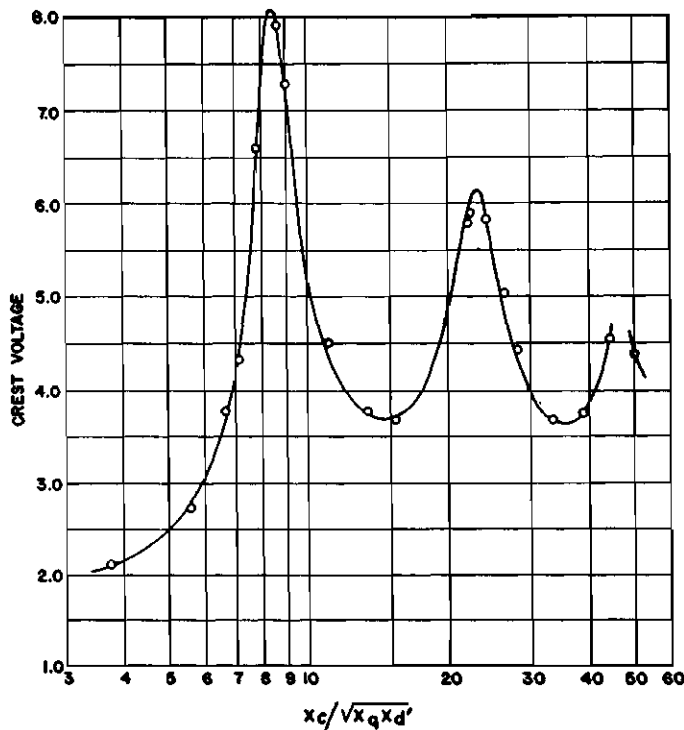

Fig. 57—Experimental values of crest voltages (twelfth cycle) from terminal a to b when switch in Fig. 54 is closed. Unit of voltage is crest of terminal-to-terminal voltage before short circuit. $x_q/x_d' = 2.2$. Machine without damper winding.

terminal-to-terminal short circuits and capacitive reactances are applied simultaneously. While a continuous or connected damper winding is most effective, a non-connected damper winding having a ratio of $\frac{x_q''}{x_d''}$ equal to at least 1.35 will be found adequate for practically all purposes.

IX. DAMPER WINDINGS

The addition of copper damper windings to machines effectively simplifies the characteristics of the machines as viewed externally in that harmonic effects are largely eliminated. However, the addition of other possible circuits for current flow complicates the internal calculations. The influence of dampers can in most cases be evaluated in terms of their effect¹⁴ upon the subtransient reactances in the two axes.

30. Types of Damper Windings

Damper windings are of several general types.

Connected Dampers—These consist essentially of windings similar to a squirrel-cage or an induction motor. They are continuous between poles as shown in Fig. 59 in which (a) shows the connection between poles for a slow-speed machine and (b) shows the additional bracing required in the form of an end ring for higher speed machines. In this type of damper, x_q'' and x_d'' have nearly the same magnitudes.

Non-connected Dampers—The dampers in each pole face are independent from those in adjacent poles, as shown

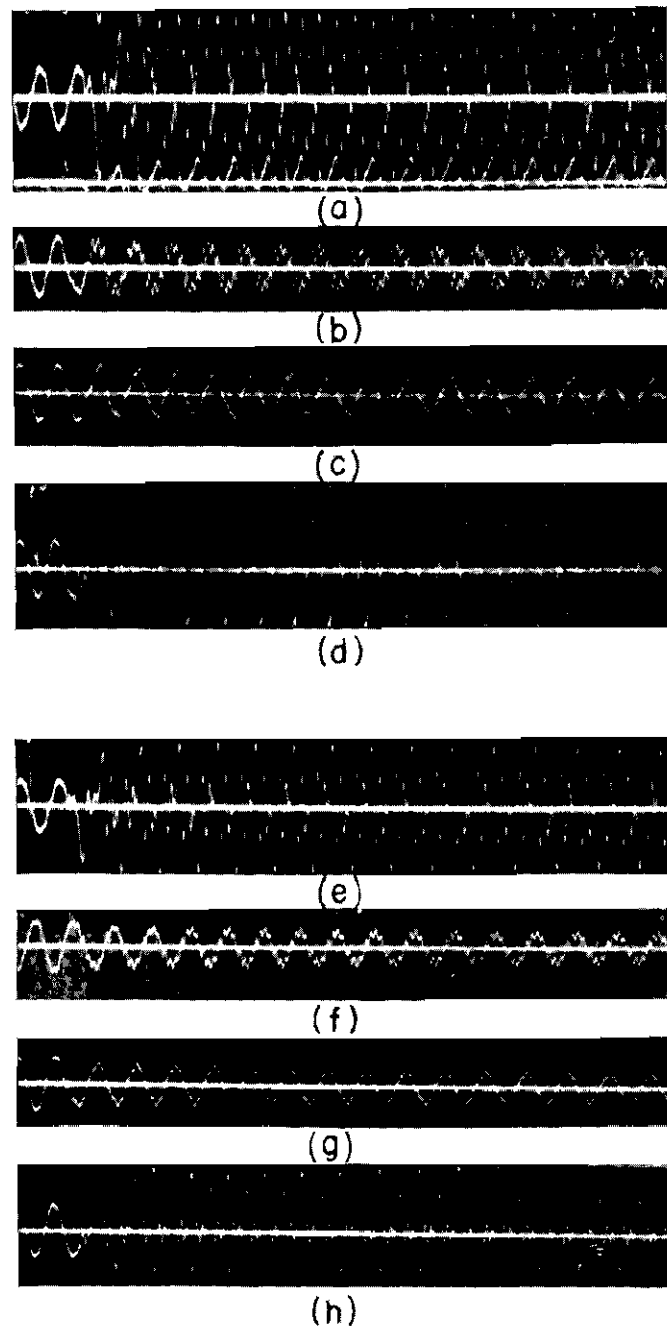

Fig. 58—Effect of damper windings.

Terminal-to-terminal short circuit:

- (a) No dampers.
- (b) Connected copper damper.
- (c) Connected high resistance damper.
- (d) Non-Connected copper damper.

Terminal-to-neutral short circuit:

- (e) No damper.
- (f) Connected copper damper.
- (g) Connected high resistance damper.
- (h) Non-connected copper damper.

in Fig. 60. They are somewhat cheaper than connected dampers but at the expense of no longer being able to make x_q'' and x_d'' equal.

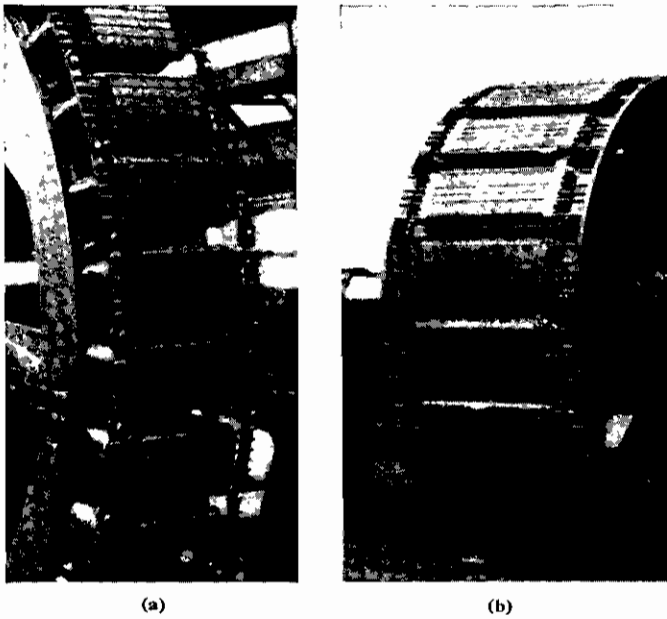

Fig. 59—Connected damper windings:
 (a) Slow-speed machine.
 (b) High-speed machine.

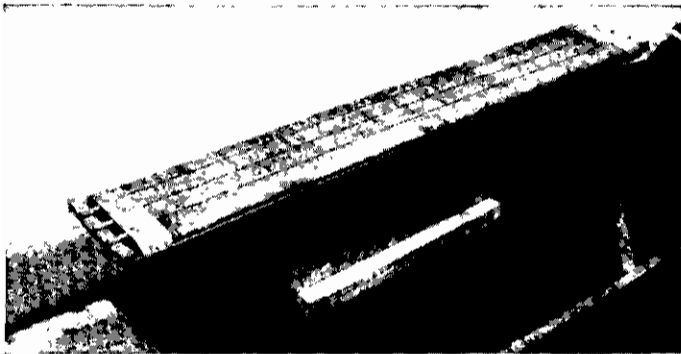

Fig. 60—Two types of non-connected damper windings.

Special Dampers—In this classification fall such dampers as double-deck windings, which are in effect a double winding, one of high resistance and low reactance and the other of low resistance and high reactance. The principal uses of this type are in motors where the combination provides better starting characteristics. At low speeds the high reactance of the low-resistance winding forces the current to flow through the high-resistance winding, which produces a high torque. At higher speeds the low-resistance winding becomes effective. Another type of special winding is one that is insulated from the iron and

connected in series to slip rings. By connecting a variable resistor externally to the slip rings the starting characteristics can be varied at will.

The general characteristics of damper windings will be discussed under the following heads.

31. Balancing Action and Elimination of Voltage Distortion

One of the earliest needs for damper windings arose from the use of single-phase generators and, later, phase balancers. Such machines if unequipped with damper windings have characteristics which resemble closely those of a three-phase machine without damper windings when a single-phase load is drawn from it. Voltage distortion similar to that discussed under unbalanced short-circuits occurs. In addition, if this condition persists the currents that flow in the body of the pole pieces, produce excessive heating. The addition of damper windings provides a low-resistance path for the flow of these currents and prevents both wave distortion and excessive heating. Because of the steady character of the load, damper windings in single-phase machines and phase balancers must be heavier than those in three-phase machines.

The best criteria of a polyphase machine to carry unbalanced load are its negative-sequence reactance and resistance. The former reflects its ability to prevent unbalancing of the voltage and the latter its ability to carry the negative-sequence current without undue heating of the rotor. These properties are particularly important for such fluctuating loads as electric furnaces. Not only do the dampers reduce voltage unbalance but also reduce wave form distortion.

32. Negative-Sequence Reactance and Resistance

As discussed previously the negative-sequence reactance and resistance of a machine are both affected by the damper windings. Table 2 shows the effect of different types of windings upon a 100-kva generator¹² and Table 3 upon a 5000-kva synchronous condenser.¹⁴ Both of these tables represent test results.

TABLE 2—CONSTANTS OF A SYNCHRONOUS GENERATOR AS AFFECTED BY TYPE OF DAMPER WINDING (100 KVA, 2300 VOLTS, 25.2 AMPERES)

Type	x_d'	x_q	$\sqrt{x_d'x_q}$	$\frac{x_q}{x_d'}$	r_{ad}''	r_{aq}''
No damper	0.260	0.577	0.388	2.22	0.028	0.105
	x_d''	x_q''	$\sqrt{x_d''x_q''}$	$\frac{x_q''}{x_d''}$		
Connected						
Copper	0.157	0.146	0.151	0.93	0.036	0.047
Connected						
Everdur	0.171	0.157	0.164	0.92	0.063	0.111
Non-connected						
Copper	0.154	0.390	0.245	2.53	0.037	0.113

33. Damping Effect

In the early days when prime movers consisted mostly of reciprocating engines the pulsating character of the

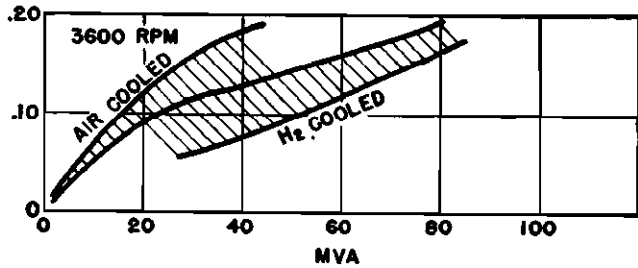
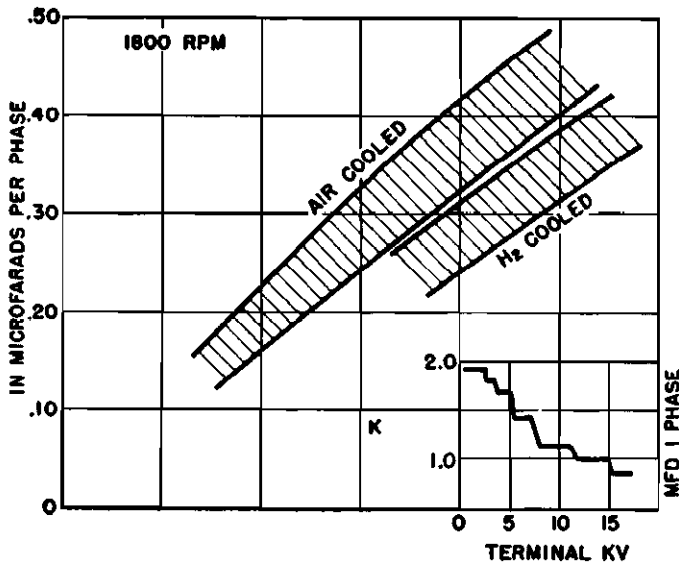

Fig. 64—Capacitance to ground of TURBINE-GENERATOR windings for 13 200-volt machines in microfarads per phase. For other voltages multiply by factor K in insert.

reactance drop x_{di} and DC the Potier reactance drop. Thus the slope of the no-load saturation curve is equal to $\frac{x_{di} - x_p i}{A_i}$. The condition for self excitation is then that

$$\frac{(x_o - x_p) i}{A_i} < \frac{(x_d - x_p) i}{A_i}$$

or

$$x_o < x_d \tag{117}$$

Stated otherwise, the machine will become self-excited if the kva of the machine as defined by $\frac{E^2}{x_d}$ is less than the

charging kva of the line $\frac{E^2}{x_c}$. Since x_d is, except for special cases, of the order of 120 percent, danger may threaten when the charging kva requirements of the line exceed approximately 80 percent of the kva of the machine.

XI. CAPACITANCE OF MACHINE WINDINGS

A knowledge of the capacitance to ground of machine windings is necessary for several reasons, among which are:

(a) Grounding of Generators. This is discussed in considerable detail in the chapter on Grounding. The capacitance to ground of the windings must be known so that the associated resistance can be selected.

(b) System Grounding. The capacitance must be known so that the contribution of this element to the ground current can be determined for single line-to-ground faults. The contribution to the fault current for this condition is equal to $\sqrt{3} 2\pi f C_o E \times 10^{-6}$ where f is the system frequency, E the line-to-line voltage and C_o the capacitance per phase in microfarads.

(c) System Recovery Voltage. The capacitance of the rotating machines may be an important element in the determination of the system recovery voltage. It is cus-

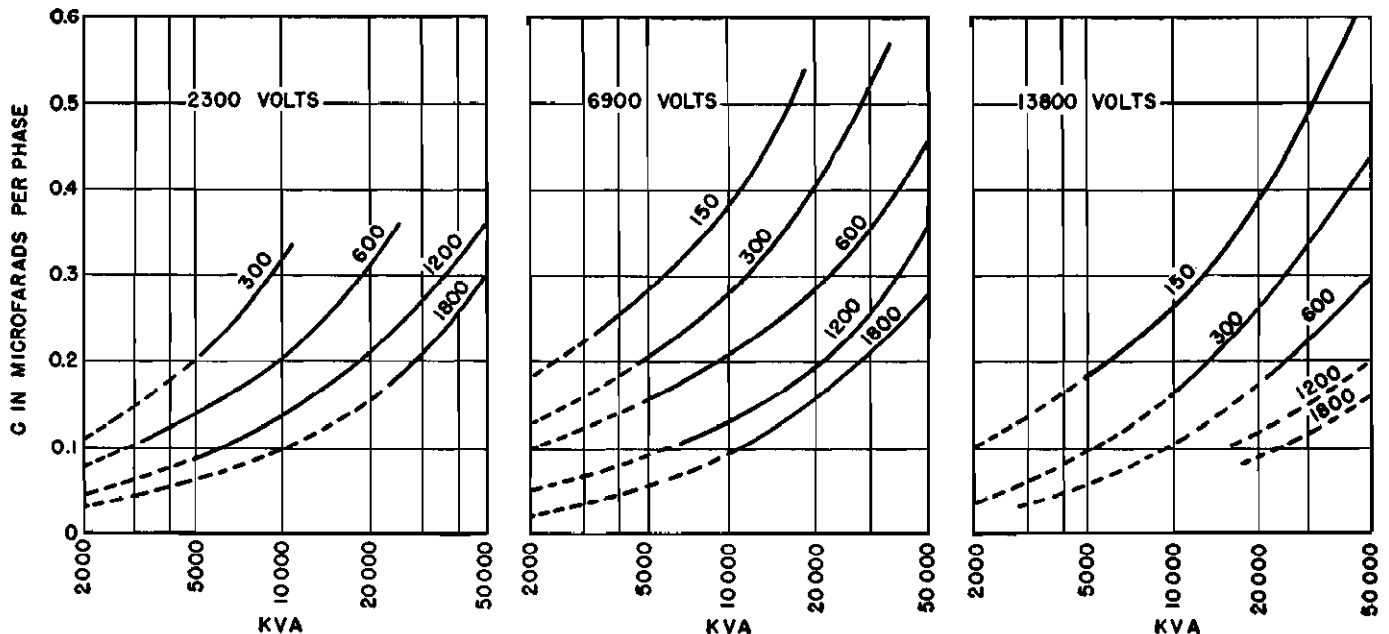

Fig. 65—Capacitance to ground of SALIENT-POLE GENERATORS AND MOTORS in microfarads per phase.

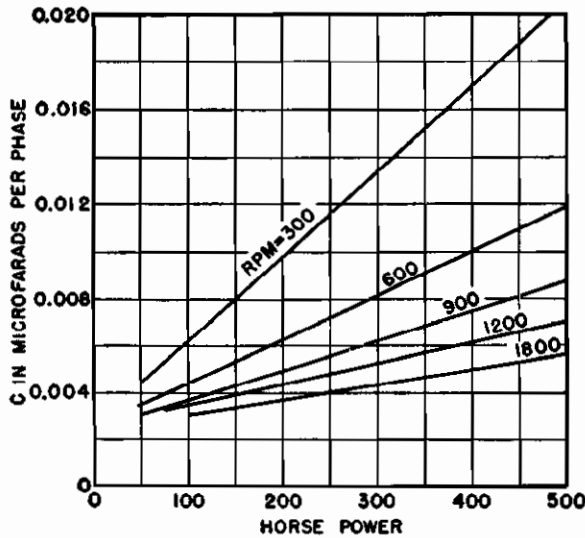

Fig. 66—Capacitance to ground of 2300-volt SYNCHRONOUS MOTORS in microfarads per phase to ground. For voltages between 2300 and 6600, the capacitance will not vary more than ± 15 percent from the values for 2300 volt.

tomary to represent the machine capacitance in this work by placing one-half of the total capacitance to ground at the machine terminal. For details of this type of calculation refer to the chapter on Power-System Voltages and Currents During Abnormal Conditions.

(d) Charging Kva. In testing the insulation of machines, particularly in the field, it is sometimes necessary to know the approximate charging kva of the windings so that a transformer of sufficiently high rating can be provided beforehand to do the job. This is required either for normal routine testing, for testing at time of installation or for testing after rewinding. The charging kva per phase is equal to $2\pi f C_0 E^2 \times 10^{-6}$ where C_0 is the

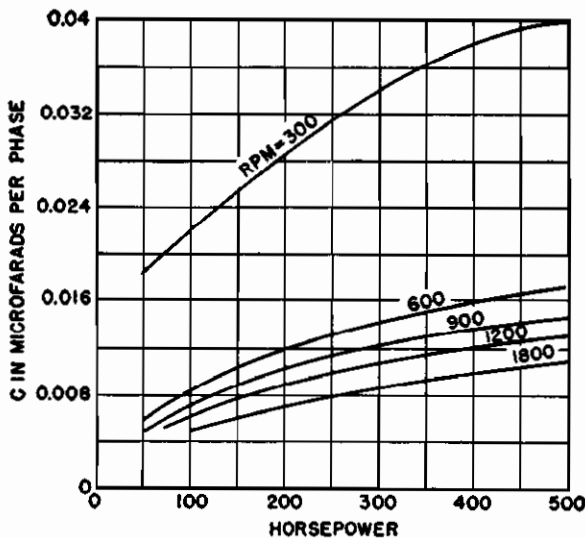

Fig. 67—Capacitance to ground of 2300-volt INDUCTION MOTORS in microfarads per phase. For voltages between 2300 and 6600, the capacitance will not vary more than ± 15 percent from the values for 2300 volts.

capacitance per phase to ground in microfarads and E is the applied voltage from winding to ground.

Figures 64 to 67 provide basic data calculated for Westinghouse turbine generators and salient-pole generators and motors. The generator data was obtained from reference 23 and the motor data from some unpublished material of Dr. E. L. Harder. This information should be typical of other machines to within about ± 50 percent. In general, it should be borne in mind that these characteristics vary greatly between machines of different designs. Fortunately, however, not very great accuracy is required for the applications cited above.

XII. NATURAL FREQUENCY OF SYNCHRONOUS MACHINE CONNECTED TO INFINITE BUS

A synchronous machine connected to an infinite bus possesses a natural period of oscillation which is given in the ASA C50—1943 Rotating Electrical Machinery Standards as

$$f_n = \frac{35\,200}{(\text{rpm})} \sqrt{\frac{P_r \times f}{WR^2}} \text{ cycles per minute} \quad (113)$$

where P_r is the synchronizing power in kw per electrical radian displacement,
 f is the system frequency.

When given an angular displacement, the machine oscillates with this frequency and finally subsides unless subjected to periodic impulse of proper magnitude. It is not within the scope of this work to discuss this subject in its entirety, but merely to derive the above expression.

If an incremental displacement $\Delta\theta$ be assumed, the corresponding synchronizing power is

$$\Delta P = P_r \Delta\theta \text{ in kw} \quad (114)$$

and $\Delta\theta$ is in degrees. From the Stability Chapter it can be seen that the acceleration of the rotor is

$$\begin{aligned} \alpha &= \frac{180 f}{\text{kva } H} \Delta P \text{ in deg/sec}^2 \\ &= \frac{\pi f}{(\text{kva}) H} \Delta P \text{ in rad/sec}^2 \end{aligned} \quad (115)$$

where the kva refers to the rating of the machine and H the inertia constant. Substituting H from Eq. (93)

$$\alpha = \frac{\pi 10^6}{0.231} \frac{f}{(WR^2)(\text{rpm})^2} \Delta P \text{ in rad/sec}^2 \quad (116)$$

and substituting ΔP from Eq. (114)

$$\alpha = \frac{\pi 10^6}{0.231} \frac{f P_r}{(WR^2)(\text{rpm})^2} \Delta\theta \quad (117)$$

$$= -K \Delta\theta. \quad (118)$$

$$K = -\frac{\pi 10^6}{0.231} \frac{f P_r}{(WR^2)(\text{rpm})^2} \quad (119)$$

The sign of P_r is actually negative as an increment in $\Delta\theta$ produces a torque which tends to return the machine to the operating angle. Thus, K is positive. Now

$$\alpha = \frac{d^2(\Delta\theta)}{dt^2} = -K \Delta\theta. \quad (120)$$

Further, let

$$\Delta\theta = A \sin 2\pi f_n t \quad (121)$$

then substituting this relation into Eq. (120)

$$-(2\pi f_n)^2 A \sin 2\pi f_n t = -KA \sin 2\pi f_n t$$

from which

$$f_n = \frac{\sqrt{K}}{2\pi}$$

Substituting K from Eq. (119)

$$f_n = \frac{587}{\text{rpm}} \sqrt{\frac{fP_r}{WR^2}} \text{ cycles per sec} \quad (122)$$

which converts to Eq. (113).

XIII. TYPICAL CONSTANTS AND COSTS

Both the voltage and the current at which a machine operates affect certain of the principal constants through the variability of the permeability of the iron. In this sense, these so-called constants are not in reality constant. Consider the transient reactance, x_d' . If three-phase short-circuits are applied to a machine from no load, the reactances so obtained vary with the excitation. Two of these quantities have been given special designations. Thus the reactance obtained when the excitation is such as to produce rated voltage at no load before the short-circuit is called the "rated-voltage reactance" and the reactance obtained when the excitation is reduced so as to produce from no load a transient component of the short-circuit

current equal to rated value is called the "rated-current reactance."

A knowledge of these two values of x_d' is not sufficient for all applications for which x_d' is required. The rated-current x_d' , because of lower excitation, lends itself more readily for determination from test. The rated-voltage x_d' is that required for short-circuit studies. Saturation within the machine is a minimum for the former and a maximum for the latter. The rated voltage value is sometimes called the "saturated value" and is the value usually given by the designer. Certain applications, such as stability studies, demand a quantity determined under conditions for which the terminal voltage is near rated voltage and the armature current is likewise near its rated current. Fig. 68 obtained from data presented by Kilgore¹⁶ shows how the reactances of typical machines of different classes vary if three-phase short-circuits were applied from rated voltage no load, the current being altered by introducing different external reactances in the armature circuits. The rated-current figure is used as a base for all the curves. The particular reactance on the curves for rated current is the one that would have greatest utility for stability and regulation problems. No specific name has been assigned to this quantity.

Similar considerations apply to the subtransient reactances, with this difference, that the rated-current reactance x_d'' is obtained from the same test as that for which the rated-current reactance of x_d' was obtained. In this case rated current refers to the transient component and not the subtransient component of current. Fig. 69 shows how

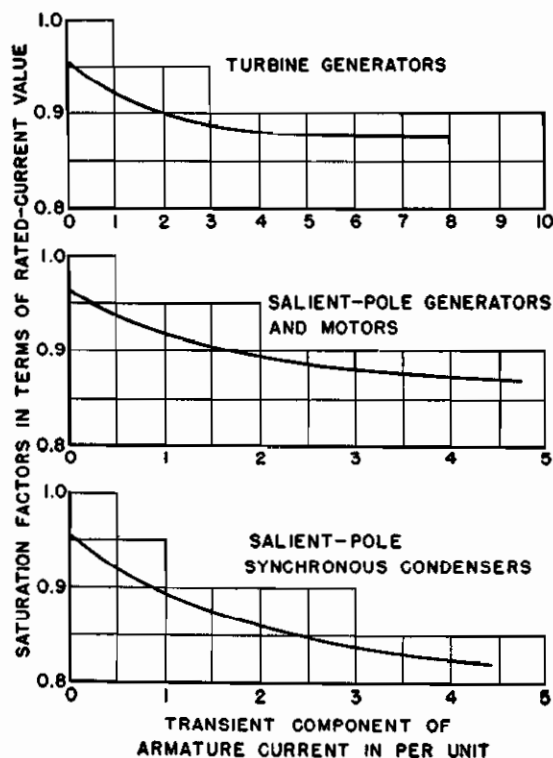

Fig. 68—Saturation factors for transient reactance. Three-phase short circuits from rated voltage no load. Current limited by series reactance.

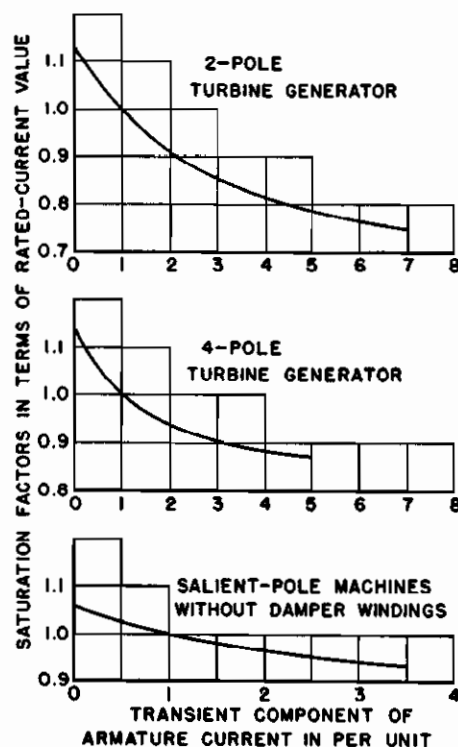

Fig. 69—Saturation factors for subtransient reactance. "Rated current" value used as base. All reactances from three-phase short circuits without external reactance. Saturation factors for salient-pole machine with damper winding is equal to unity.

x_d'' varies with the transient component of current, all points being obtained from three-phase short-circuits with no external reactance, the current being altered by the excitation before the short-circuit.

In general, it is unnecessary to make this distinction for the negative-sequence reactance. The *AIEE* code¹⁰ suggests determination of x_2 by means of the method discussed

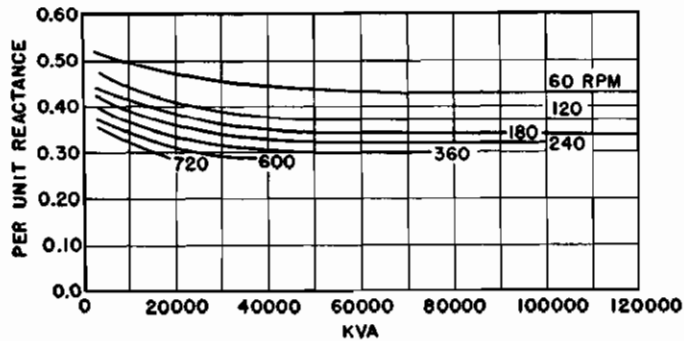

Fig. 70—Normal unsaturated transient reactance ($x_{d'u}$) for waterwheel generators.

under Negative-Sequence Reactance, the current during the sustained terminal-to-terminal short-circuit being limited to the rated current.

The normal value of x'_{du} designed into waterwheel generators varies with the kva capacity and speed. These values are plotted in curve form in Fig. 70. To obtain lower values than those indicated usually involves an increased cost.

The angular relations within the machine are determined to a large extent by x_q . The variation, by test, of x_q for several salient-pole machines^{12,17} is shown in Fig. 71.

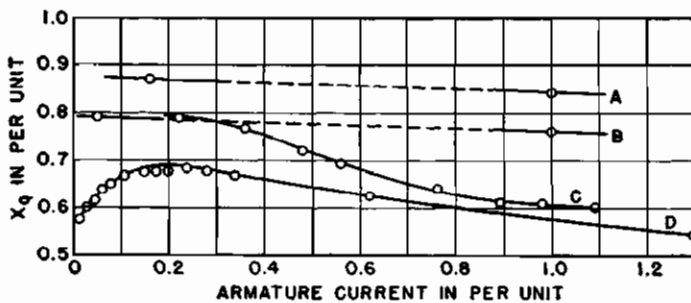

Fig. 71— x_q for salient-pole machines.

- A = 7500 kva generator without damper winding.
- B = 750 kva generator without damper winding.
- C = 331 kva motor with damper winding removed.
- D = 100 kva generator with damper winding.

The zero-sequence reactance, as evidenced by Fig. 72 taken from Wright's paper,¹⁷ is not affected to any great extent in the region for which it has greatest use.

For practical purposes the effect of saturation upon the open-circuit transient time constant $T_{d'o}$ and the sub-transient short-circuit time constant T_d'' can be neglected. In general, T_d' varies¹⁷ in the same manner as x_d' , so that the relation $T_d' = \frac{x_d'}{x_d} T_{d'o}$ is still maintained. Because of

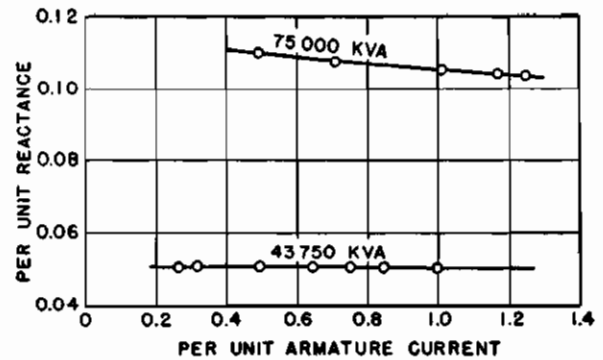

Fig. 72—Variation of x_0 for turbine generators.

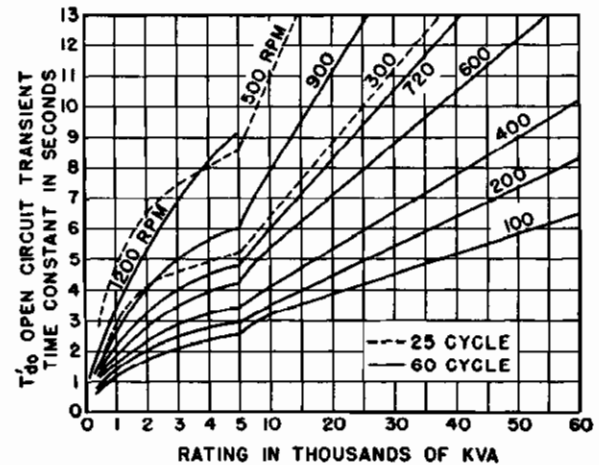

Fig. 73—Open-circuit transient time constants of a-c generators and motors.

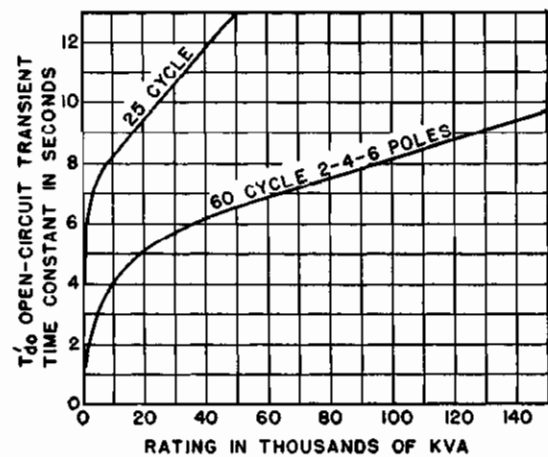

Fig. 74—Open-circuit transient time constants of turbine generators.

the wide variation of $T_{d'o}$ with the size of the unit the curves of Figs. 73 and 74 taken from a paper by Hahn and Wagner,¹⁸ are also included.

Table 4 gives both the range of typical constants that are characteristic of normal designs and also an average that can be used for general purposes when the specific value of a particular machine is not known. The negative-sequence resistance is that obtained at a negative-sequence current equal to rated current. It must be kept in mind

that the loss associated therewith varies as the second power of i_2 for salient-pole machines either with or without damper windings and as the 1.8 power of i_2 for turbine generators. Column (9) in Table 4 refers to the a-c resistance, r_1 , (which includes the effect of load losses) and column (10) the d-c resistance, r_a .

The inertia constant, H , which is discussed in Chap. 13 is likewise given in Table 4. The general variation of H of turbogenerators and the corresponding figures for water-wheel generators are given in Fig. 75. The effect upon H

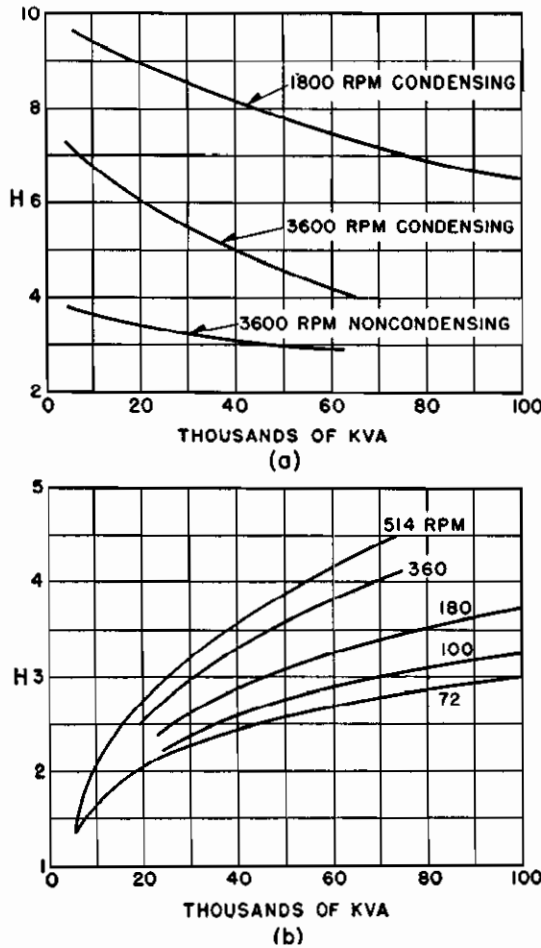

Fig. 75—Inertia constants.

- (a) Large turbine generators, turbine included.
- (b) Large vertical type waterwheel generators, including allowance of 15 percent for waterwheels.

of increasing the short-circuit ratio and changing the power-factor is given in Fig. 76. The WR^2 represented by the curves of Figs. 75 and 76 are those obtained from a normally designed machine in which no particular effort has been made to obtain abnormally high H . When magnitudes of WR^2 in excess of these are desired a more expensive machine results. The additional cost of the additional WR^2 is about proportional as shown in Fig. 77.

The cost per kva of water-wheel generators depends upon its kva and speed. The extent of this variation is shown in Fig. 78. Machines of higher short-circuit ratio or power-factor are more expensive in the proportion shown

TABLE 4—TYPICAL CONSTANTS OF THREE-PHASE SYNCHRONOUS MACHINES

	1	2	3	4	5	6	7	8	9	10	11	12	13	14	15
	x_d (unsat)	x_0 rated current	x_d' rated voltage	x_d'' rated voltage	x_2 rated current	x_0 rated current	x_p	(t) r_2	(t) r_1	(t) r_a	T_{d0}'	T_d'	T_d''	T_s	H
2-Pole turbine generators	1.20 0.95-1.45	1.16 0.92-1.42	0.15 0.12-0.21	0.09 0.07-0.14	0.03 0.01-0.08	0.03 0.01-0.08	0.10 0.07-0.17	0.025-0.04	0.004-0.011	0.001-0.007	5.0 See Fig. 74	0.6 See Fig. 74	0.035 0.02-0.05	0.13 0.04-0.24	See Fig. 75(a)
4-Pole turbine generators	1.20 1.00-1.45	1.16 0.92-1.42	0.23 0.20-0.28	0.14 0.12-0.17	0.08 0.015-0.14	0.08 0.015-0.14	0.17 0.12-0.24	0.03-0.045	0.003-0.008	0.001-0.005	8.0 See Fig. 74	1.0 See Fig. 74	0.035 0.02-0.05	0.20 0.13-0.35	See Fig. 75(a)
Salient-pole generators and motors (with dampers)	1.25 0.60-1.50	0.70 0.40-0.80	0.30 0.20-0.50(*)	0.20 0.13-0.32(*)	0.20 0.13-0.32(*)	0.18 0.03-0.23	0.28 0.17-0.40	0.012-0.020	0.005-0.020	0.003-0.015	See Fig. 73 3.0-5.0 1.5-10	1.5 0.5-3.3	0.035 0.01-0.05	0.15 0.03-0.25	See Fig. 75(b)
Salient-pole generators (without dampers)	1.25 0.60-1.50	0.70 0.40-0.80	0.30 0.20-0.50(*)	0.30 0.20-0.50(*)	0.48 0.35-0.65	0.19 0.03-0.24	0.28 0.17-0.40	0.03-0.045	0.005-0.020	0.003-0.015	See Fig. 73 3.0-5.0 1.5-10	1.5 0.5-3.3	—	0.30 0.10-0.50	See Fig. 75(b)
Condensers air cooled	1.85 1.25-2.20	1.15 0.93-1.30	0.40 0.30-0.50	0.27 0.19-0.30	0.26 0.18-0.40	0.12 0.025-0.15	0.25 0.20-0.35	0.025-0.07	0.0005	0.0035	9.0 6.0-14.0	2.0 1.2-2.8	0.035 0.02-0.04	0.17 0.1-0.3	Large 2.4 Small 1.0
Condensers hydro- gen cooled at 3/4 psi kva rating	2.20 1.50-2.65	1.35 1.10-1.55	0.48 0.36-0.60	0.32 0.23-0.36	0.31 0.22-0.48	0.14 0.030-0.18	0.27- 0.22-0.37	0.025-0.07	0.0065	0.0035	9.0 6.0-14.0	2.0 1.2-2.8	0.035 0.02-0.04	0.20 0.15-0.3	Large 2.0 Small 1.10

(*) High speed units tend to have low reactance and low speed units high reactance.
 (†) x_0 varies so critically with armature winding pitch that an average value can hardly be given.
 (‡) r_1 and r_a vary with machine rating, limiting values given are for about 50,000 kva and 500 kva.
 (§) r_2 varies with damper resistance.

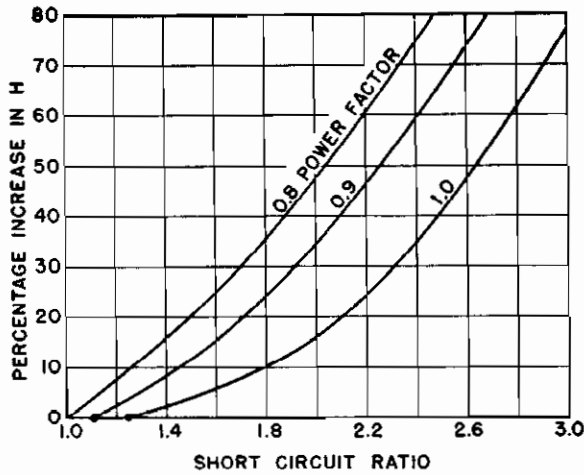

Fig. 76—Effect of short-circuit ratio upon H.

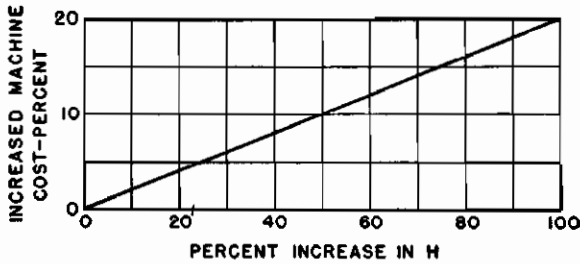

Fig. 77—Effect of increasing H above the normal values given by Fig. 75.

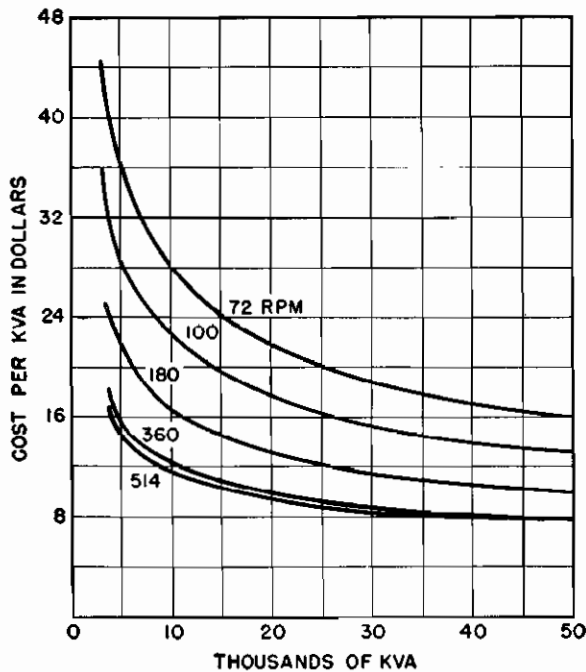

Fig. 78—Cost of waterwheel generators including direct-connected exciters only.

(0.8 power-factor and 1.0 short circuit ratio)
 (0.9 power-factor and 1.1 short circuit ratio)
 (1.0 power-factor and 1.25 short circuit ratio)

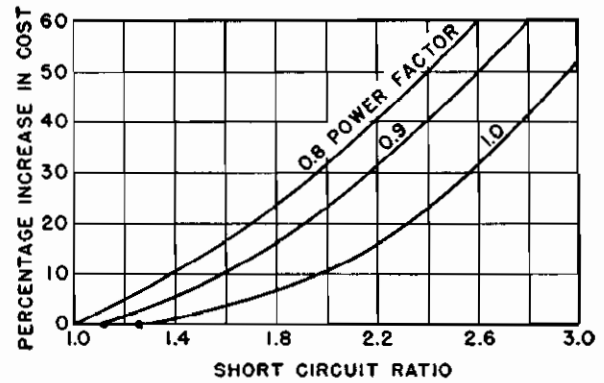

Fig. 79—Effect of short-circuit ratio upon cost (Normal 1.0 short-circuit ratio and 0.8 power-factor used as base).

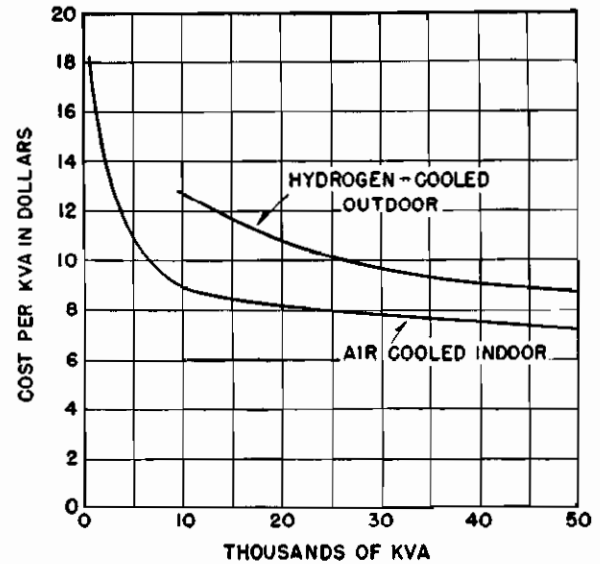

Fig. 80—Cost of synchronous condensers including exciter and autotransformer.

in Fig. 79. Naturally these figures will vary from year to year with the cost of materials and labor.

The condenser cost per kva including the exciter, pilot exciter, and auto-transformer is plotted in Fig. 80. The exciter kw varies with the size of the unit, ranging from 1.2, 0.7, and 0.32 percent for a 1000, 5000, and 50 000-kva unit, respectively.

The cost of normal exciters for water-wheel generators varies from 7 to 13 percent of the cost of the generator alone for slow speeds, and from 2.5 to 6 percent for high speeds. The larger figures apply for units of about 3000 kva and the smaller figures for machines of about 50 000 kva. Direct-connected pilot exciters cost approximately 30 percent of that of the exciter.

XIV. INDUCTION MOTORS

The equivalent circuit of the induction motor is shown in Fig. 31. The loss in the resistor $\frac{1-s}{s}r$, represents the shaft power and since the circuit is on a per phase basis, the total shaft power is thus

$$\text{Total shaft power} = \frac{1-s}{s}(3r_r i_r^2) \text{ in watts} \quad (123)$$

$$= \frac{1}{746} \frac{1-s}{s}(3r_r i_r^2) \text{ in hp.} \quad (124)$$

The rotor copper loss is $(3r_r i_r^2)$. Therefore, neglecting other losses, the efficiency is:

$$\begin{aligned} \text{Efficiency} &= \frac{\text{total shaft power}}{\text{total shaft power} + \text{rotor copper loss}} \\ &= \frac{1-s}{s} \\ &= \frac{1-s}{\frac{1-s}{s} + 1} \end{aligned} \quad (125)$$

Thus, the efficiency decreases with increasing slip. For 10 percent slip the efficiency is 90 percent, for 90 percent slip the efficiency is 10 percent. Similarly, the rotor copper loss is directly proportional to slip; being 10 percent for 10 percent slip and 90 percent for 90 percent slip.

The total shaft power can also be expressed in terms of torques. Thus,

$$\text{Total shaft horse power} = \frac{2\pi}{33\,000} (T \text{ in lb ft}) (\text{rpm})_{\text{syn.}} (1-s). \quad (126)$$

Equating (124) and (126), the torque is

$$T = 7.04 \frac{1}{(\text{rpm})_{\text{syn.}}} \frac{(3r_r i_r^2) \text{ in watts}}{s \text{ in per unit}} \text{ lb ft.} \quad (127)$$

The equivalent circuit of Fig. 31 can be simplified considerably by shifting the magnetizing branch to directly across the terminals. The resultant approximate circuit is shown in Fig. 81. This approximation permits of

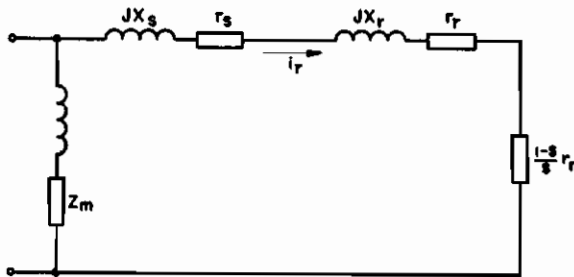

Fig. 81—Approximate equivalent circuit of induction motor.

relatively simple determination of i_r , so that Eq. (127) becomes

$$T = \frac{7.04E^2}{(\text{rpm})_{\text{syn.}}} 3 \frac{\frac{r_r}{s}}{\left(r_s + \frac{r_r}{s}\right)^2 + (x_s + x_r)^2} \text{ lb ft.} \quad (128)$$

Most transients involving induction motors fall within one of two categories; first, those in which the machine is disconnected from the source of power and, second, those in which the machine remains connected to the source of power. In the first case the transient is determined largely by changes in magnetization and may be quite long. An

example of this case is the phenomena that occurs during the interval between the transfer of power-house auxiliaries from one source to another. In the second case, the transient is determined by reactions involving both the stator and rotor and the duration is quite short. Examples, of this case, are the sudden energization of an induction motor or sudden short circuit across its terminals.

35 Contribution to System Short-Circuit Current

In the calculation of system short circuits only synchronous machines are usually considered but in special cases where induction machines constitute a large proportion of the load, their contribution to the short-circuit current even if its duration is only a few cycles may be large enough to influence the choice of the breaker from the standpoint of its short-time rating, that is, the maximum rms current the breaker can carry for any time, however small.

As a first approximation the short-circuit current supplied by an induction motor can be resolved into an alternating and a unidirectional component much like that for a synchronous machine. The initial rms magnitude of the alternating component is equal to the terminal voltage to neutral divided by the blocked rotor impedance per phase. The time constants are namely,

$$\frac{(\text{blocked rotor reactance per phase in ohms})}{2\pi (\text{rotor resistance per phase in ohms})} \text{ in cycles.}$$

for the unidirectional component,

$$\frac{(\text{blocked rotor reactance per phase in ohms})}{2\pi (\text{stator resistance per phase in ohms})} \text{ in cycles.}$$

Fig. 82 shows the short-circuit current of a 25-horse-power, 550-volt squirrel-cage motor. The dotted line in the upper

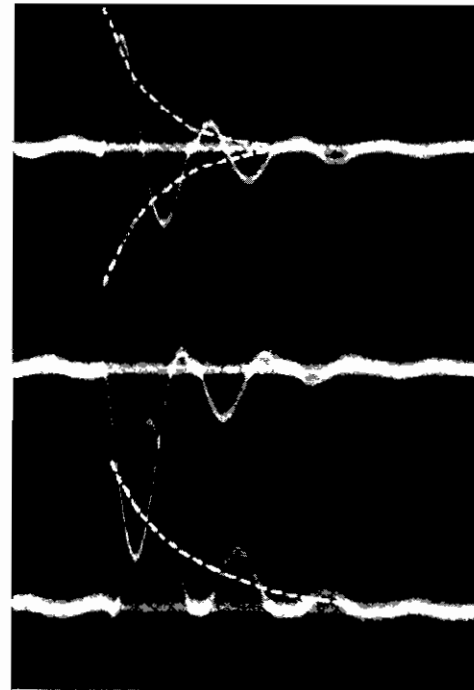

Fig. 82—Short-circuit currents in armature of squirrel-cage induction motor.

curve indicates the computed value of the envelope of the alternating component of short-circuit current. The amplitude shows a substantial check but the computed time constant was low. This can probably be attributed to using the a-c resistance of the rotor rather than the d-c resistance. The dotted line in the lower curve is the computed value of the unidirectional component which checks quite well.

Wound-rotor motors, operated with a substantial amount of external resistance, will have such small time constants that their contribution to the short-circuit can be neglected.

36. Electro-Mechanical Starting Transient

Fig. 31 shows the conventional diagram of an induction motor. In the present discussion the per unit system of units will continue to be used, in which unit current is the current necessary to develop the rated power at the rated voltage. The unit of both power and reactive volt-amperes will be the rated kva of the motor and *not* the rated power either in kilowatts or horse power. This convention is consistent with the choice of units for the impedances. At rated slip the volt-amperes input into the stator must be equal to unity but the power absorbed in the resistor $\frac{1-s}{s}r_r$ will be less than unity and will be equal numerically to the ratio of the rated power of the motor to the rated kva. The unit of shaft torque requires special comment. The shaft power can be expressed as

$$\text{Shaft Power in kw} = \text{kva}_{\text{rated}} I_r^2 \frac{1-s}{s} \tag{129}$$

In terms of torque the shaft power is equal to
Shaft Power in kw

$$= 0.746 \frac{T \text{ in lb ft } 2\pi(\text{rpm})_{\text{synch.}}(1-s)}{33\,000} \tag{130}$$

Equating, there results that

$$T \text{ in lb ft} = \frac{33\,000}{2\pi(0.746)(\text{rpm})_{\text{synch.}}} \text{kva}_{\text{rated}} I_r^2 \frac{r_r}{s} \tag{131}$$

If unit torque be defined as that torque required to produce a shaft power equal to rated kva at synchronous speed, then from (130), the unit of torque is

$$\frac{33\,000}{2\pi(0.746)(\text{rpm})_{\text{synch.}}} \text{kva}_{\text{rated}}$$

and equation (131) in per unit becomes

$$T \text{ in p.u.} = I_r^2 \frac{r_r}{s} \tag{132}$$

For the purpose of determining the nature of electro-mechanical transients upon starting a motor from rest, the first step involves the calculation of the shaft torque as a function of the speed. Either the conventional method of the circle diagram or expression (132) can be used. In using the latter method it is only necessary to solve the network of Fig. (31) and substitute the solution of I_r therefrom into Eq. (132). A solution of a typical motor is shown in Fig. 83. For most motors the magnetizing branch can be neglected, for which case the torque expression becomes

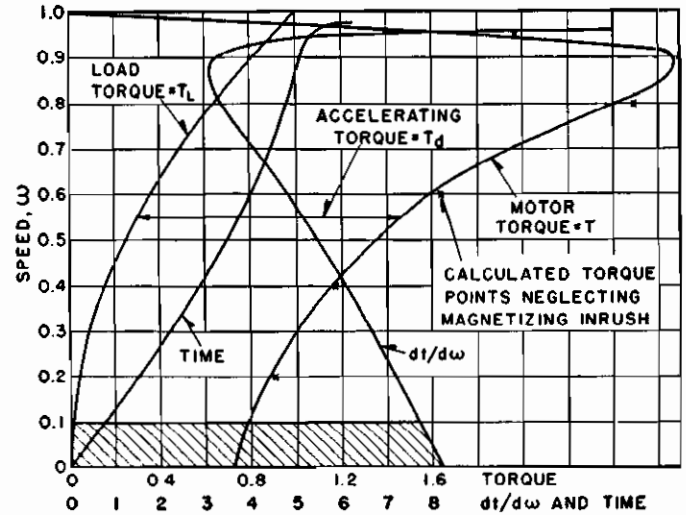
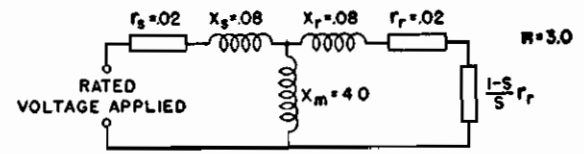

Fig. 83—Illustrating calculation of speed-time curve of an induction motor upon application of full voltage.

$$T \text{ in per unit} = e_s^2 \frac{\frac{r_r}{s}}{(x_s + x_r)^2 + \left(r_s + \frac{r_r}{s}\right)^2} \tag{133}$$

The crosses close to the torque curve in Fig. 83 were computed by this expression.

In Fig. 83 is also shown the torque requirements of a particular load such as a blower. Upon applying voltage to the motor the difference between the torque developed by the motor and that required by the load is the torque available for acceleration of the rotor. To convert to acceleration it is convenient to introduce a constant, H , which is equal to the stored energy in kw-sec. per kva of rating at synchronous speed. H may be computed by means of Eq. (93). WR^2 must, of course, include the WR^2 of the connected load.

Suppose that one per unit torque is applied to the motor which means that at synchronous speed the power input into acceleration of the rotor is equal to rated kva, and suppose further that the rotor is brought to synchronous speed in one second. During this interval the acceleration is constant (1 per unit) and the power input increases linearly with time so that at the end of one second the stored energy of rotation is $(\frac{1}{2} \text{ kva})$ in kw-sec. Thus 1 per unit of torque produces 1 per unit of acceleration if the inertia is such that $\frac{1}{2}$ kva of stored energy is produced in one second. From this it can be seen that if the inertia is such that at synchronous speed the stored energy is H , then to develop this energy in one second, the same acceleration but a torque $2H$ times as great is required. Therefore, there results that

$$\alpha = \frac{T - T_L}{2H} \tag{134}$$

Acceleration can be expressed as $\frac{d\omega}{dt}$ and its reciprocal as $\frac{dt}{d\omega}$. Thus from (134)

$$\frac{dt}{d\omega} = \frac{2H}{T - T_L} \quad (135)$$

This function is likewise plotted in Fig. 83. The utility of this form of the expression may be seen at once from the fact that $\frac{dt}{d\omega}$ is known as a function of ω and the time to reach any value of ω can be determined by a simple integration. Thus

$$t = \int \left(\frac{dt}{d\omega} \right) d\omega \quad (136)$$

By summing up areas (such as indicated by the shaded portion) in a vertical direction, the time to reach any speed is obtained. The curve of time so obtained is plotted in Fig. 83.

The following formula can be used to form an approximate idea of the time required to accelerate a motor, whose load varies as the square or cube of the speed, to half speed

$$\text{Time to half speed} = \frac{H(x_s + x_r)^2}{r_r e^2 t} \text{ in seconds} \quad (137)$$

All of the above units must be expressed in per unit. Remember also that x_s should include any external reactance in the stator back to the point where the voltage may be regarded as constant and e_t should be that constant voltage.

37. Residual Voltage

If an induction motor is disconnected from its supply, it rotates for some time, the rate of deceleration being determined by the inertia of its own rotor and the inertia of the load and also by the nature of the load. Because of the inductance of the rotor, flux is entrapped and voltage

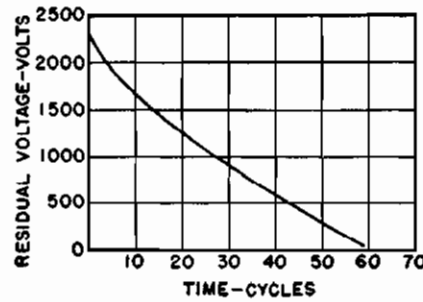

Fig. 84—Decay of residual voltage²⁵ of a group of power house auxiliary motors.

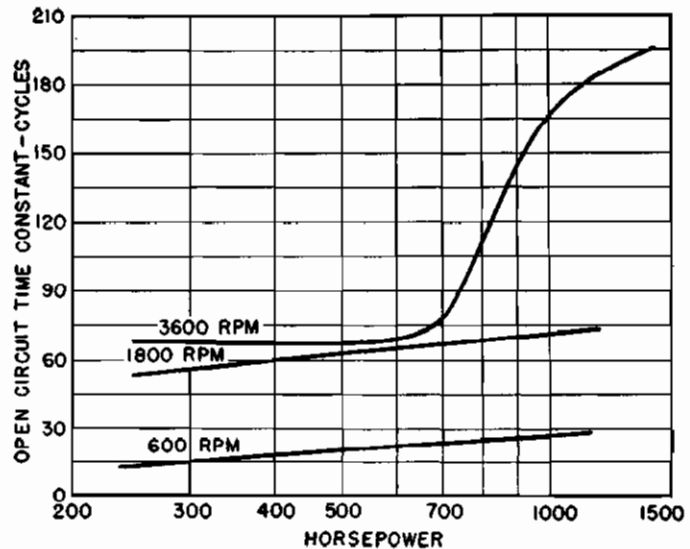

Fig. 85—Typical time constants for 2300-volt squirrel cage induction motors.

appears at the open terminals of the machine. If the voltage source is reapplied when the source voltage and residual voltage of the motor are out of phase, currents exceeding starting values may be obtained.

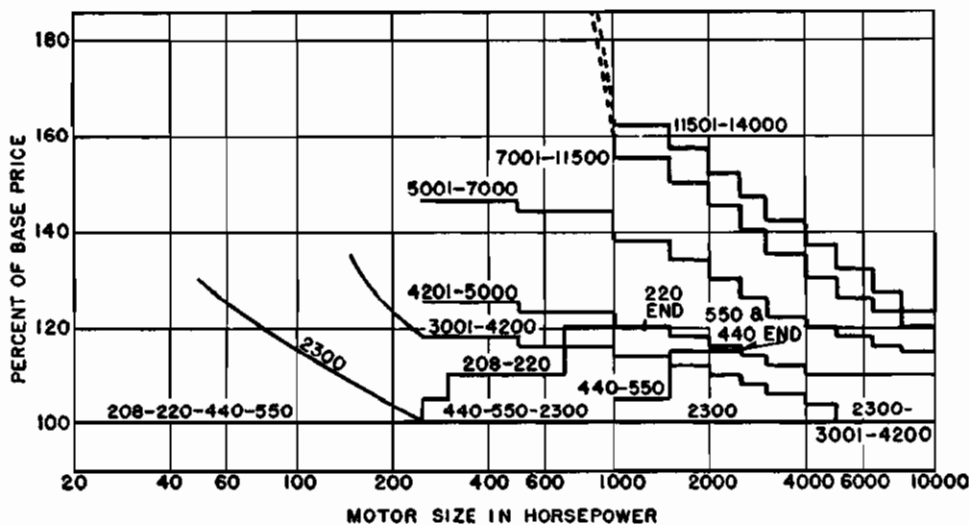

Fig. 86—Approximate variation of price with voltage and horsepower of squirrel-cage induction motors. These values apply approximately for 8 poles or less for 60-cycle motors. Most economical used as base price.

Figure 84 shows the decay of a group of power-house auxiliary motors²⁶. The group had a total rating of 2500 kw of which the largest was 1250 hp. This curve includes not only the effect of magnetic decay but the reduction in voltage due to decrease in speed. The open-circuit time constant for individual 2300-volt machines is given in Fig. 85. There is a great variance in this constant between different designs but these curves give an idea of the magnitude for squirrel-cage induction machines.

38. Cost of Induction Motors

The price of induction motors of a given rating varies with the voltage. As the rating increases the most economical voltage also increases. To form a basis of judgment of the effect of voltage upon size the curve in Fig. 86 was prepared.

REFERENCES

1. Power System Transients, by V. Bush and R. D. Booth, *A.I.E.E. Transactions*, Vol. 44, February 1925, pp. 80-97.
2. Further Studies of Transmission Stability, by R. D. Evans and C. F. Wagner, *A.I.E.E. Transactions*, Vol. 45, 1926, pp. 51-80.
3. Synchronous Machines—I and II—An extension of Blondel's Two Reaction-Theory—Steady-State Power Angle Characteristics, by R. E. Doherty and C. A. Nickle, *A.I.E.E. Transactions*, Vol. 45, 1926, pp. 912-942.
4. Synchronous Machines—III. Torque Angle Characteristics Under Transient Conditions, by R. E. Doherty and C. A. Nickle, *A.I.E.E. Transactions*, Vol. 46, 1927, pp. 1-14.
5. Synchronous Machines, IV, by R. E. Doherty and C. A. Nickle, *A.I.E.E. Transactions*, Vol. 47, No. 2, April 1928, p. 457.
6. Synchronous Machines, V. Three-Phase Short Circuit Synchronous Machines, by R. E. Doherty and C. A. Nickle, *A.I.E.E. Transactions*, Vol. 49, April 1930, p. 700.
7. Definition of an Ideal Synchronous Machine and Formula for the Armature Flux Linkages, by R. H. Park, *General Electric Review*, June 1928, pp. 332-334.
8. Two-Reaction Theory of Synchronous Machines—I, by R. H. Park, *A.I.E.E. Transactions*, Vol. 48, No. 2, July 1929, p. 716.
9. Two-Reaction Theory of Synchronous Machines, II, by R. H. Park, *A.I.E.E. Transactions*, Vol. 52, June 1933, p. 352.
10. *A.I.E.E. Test Code for Synchronous Machines*. A.I.E.E. Publication No. 503, June 1945.
11. Discussion, by C. F. Wagner, *A.I.E.E. Transactions*, July 1937, p. 904.
12. Unsymmetrical Short-Circuits in Water-Wheel Generators Under Capacitive Loading, by C. F. Wagner, *A.I.E.E. Transactions*, November 1937, pp. 1385-1395.
13. Overvoltages on Water-Wheel Generators, by C. F. Wagner, *The Electric Journal*, August 1938, p. 321 and September 1938, p. 351.
14. Damper Windings for Water-Wheel Generators, by C. F. Wagner, *A.I.E.E. Transactions*, Vol. 50, March 1931, pp. 140-151.
15. Effect of Armature Resistance Upon Hunting of Synchronous Machines, by C. F. Wagner, *A.I.E.E. Transactions*, Vol. 49, July 1930, pp. 1011-1024.
16. Effects of Saturation on Machine Reactances, by L. A. Kilgore, *A.I.E.E. Transactions*, Vol. 54, 1935, pp. 545-550.
17. Determination of Synchronous Machine Constants by Test, by S. H. Wright, *A.I.E.E. Transactions*, Vol. 50, 1931, pp. 1331-1350.
18. Standard Decrement Curves, by W. C. Hahn and C. F. Wagner, *A.I.E.E. Transactions*, 1932, pp. 353-361.
19. Approximating Potier Reactance, by Sterling Beckwith, *A.I.E.E. Transactions*, July 1937, p. 813.
20. Auxiliary Power at Richmond Station, by J. W. Anderson and A. C. Monteith, *A.I.E.E. Transactions*, 1927, p. 827.
21. Preferred Standards for Large 3600-RPM 3-Phase 60-Cycle Condensing Steam Turbine-Generators, AIEE Standards Nos. 601 and 602, May 1949.
22. Regulation of A-C Generators With Suddenly Applied Loads, by E. L. Harder and R. C. Cheek, *A.I.E.E. Transactions*, Vol. 63, 1944, pp. 310-318.
23. Regulation of A-C Generators with Suddenly Applied Loads—II, by E. L. Harder and R. C. Cheek, *A.I.E.E. Transactions*, 1950.
24. Practical Calculation of Circuit Transient Recovery Voltages, by J. A. Adams, W. F. Skeats, R. C. Van Sickle and T. G. A. Sillers, *A.I.E.E. Transactions*, Vol. 61, 1942, pp. 771-778.
25. Bus Transfer Tests on 2300-Volt Station Auxiliary System, by A. A. Johnson and H. A. Thompson, presented before AIEE Winter Meeting, Jan. 1950.

EXCITATION SYSTEMS

Author:

J. E. Barkle, Jr.

PRIOR to 1920 relatively little difficulty was encountered in the operation of electrical systems, and operating engineers had little concern about system stability. As the loads grew and systems expanded, it became necessary to operate synchronous machines in parallel, and difficulties encountered were not well understood. In certain areas it became necessary to locate generating stations some distance from the load centers, which involved the transmission of power over long distances. It soon became apparent that system stability was of vital importance in these cases and also in the operation of large interconnected systems.

In 1922, a group of engineers undertook solution of the stability problem to determine the factors involved that most affected the ability of a system to transfer power from one point to another. The results of these studies were presented before the AIEE in a group of papers* in 1924, and it was pointed out that the synchronous machine excitation systems are an important factor in the problem of determining the time variation of angle, voltage, and power quantities during transient disturbances. E. B. Shand stressed the theoretical possibility of increasing the steady-state power that could be transmitted over transmission lines through the use of a generator voltage regulator and an excitation system with a high degree of response so that operation in the region of dynamic stability would be possible. It was not recommended that this region of dynamic stability be considered for normal operation, but that it be considered additional margin in determining permissible power transfer.

Improvement of the excitation systems, therefore, appeared to be at least one method of increasing the stability limits of systems and preventing the separations occurring during transient conditions. Greater interest in the design of excitation systems and their component parts developed, and exciters with higher speeds of response and faster, more accurate generator voltage regulators were soon introduced to the industry.

Early excitation systems were of many different forms depending principally upon whether the main generators were small or large in rating and whether the installation was a steam or hydroelectric station. The two broad classifications were those using a common excitation bus and those using an individual exciter for each main generator. The common exciter bus was generally energized by several exciters driven by motors, turbines, steam engines, waterwheels, or combinations of these to provide a main and emergency drive. Standby exciter capacity was provided in the common-bus system by a battery floated

on the bus. It usually had sufficient capacity to carry the excitation requirements of the entire station for at least an hour.

Motor or turbine drive was also used in the individual-exciter system, but it was not long before it was realized that direct-connection of the exciter to the generator shaft offered an excellent answer to the many problems encountered with separately-driven exciters and this system grew rapidly in popularity. The standby excitation source was usually a spare exciter, either motor- or turbine-driven, and in case of trouble with the main exciter, transfer was accomplished manually.

Pilot exciters had not been used up to that time. The exciters were invariably self-excited. In the common-bus system without a floating battery, the bus was operated at constant voltage supplied by compound-wound d-c generators. Thus, practically constant voltage was obtained on the bus and control of the individual a-c generator field voltage was accomplished by using a variable rheostat in each field as shown in Fig. 1. When a standby battery was

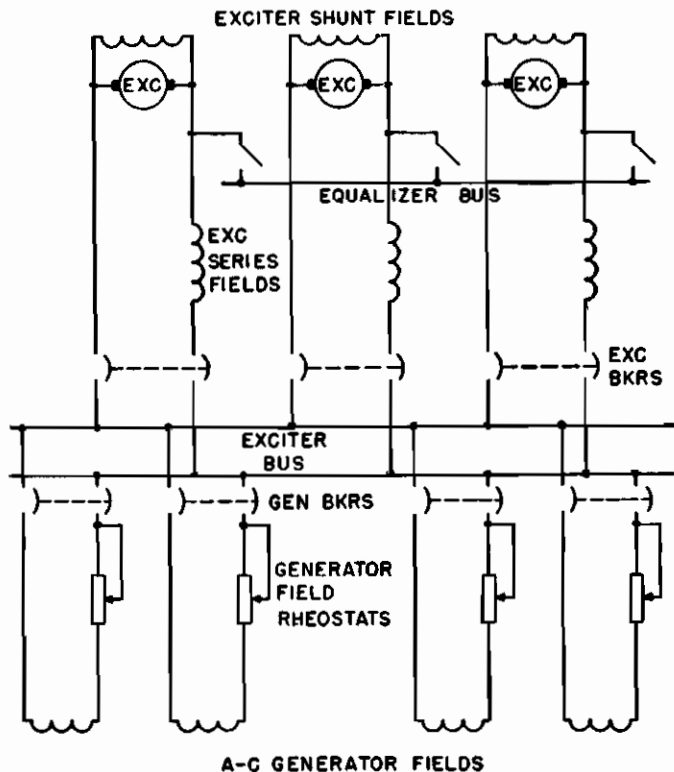

Fig. 1—Common-exciter-bus excitation system using flat-compounded exciters and a-c generator field rheostats.

*A.I.E.E. Transactions, Vol. 43, 1924, pp. 16-103.

floated on the common bus, however, the exciters were shunt-wound to prevent polarity reversal by reversal of the series-field current. The a-c generator-field rheostat required in the common-bus system was a large and bulky device, which had considerable loss and required a great deal of maintenance. Control of voltage was under hand-regulation.

In the individual-exciter system, the exciter was a shunt-wound machine with field control enabling it to operate as a variable-voltage source. The exciter usually operated at voltages between 30 and 100 percent, lower field voltages being obtained with a generator-field rheostat so that the exciter could operate slightly saturated and be stable.

The generator voltage regulators in use at that time were predominantly of the continuously-vibrating type. The fact that these regulators were not suitable for use with the new exciters with fast response and high ceiling voltages prompted the development of new types of regulators.*

In the past 25 years, there have been many developments in excitation-system design and practices. There is an unceasing search among designers and users alike to find ways of improving excitation-system performance through use of various types of d-c generators, electronic converters, and better controlling devices. The ultimate aim is to achieve an ideal in rate of response, simplicity, reliability, accuracy, sensitivity, etc. The achievement of all of these ideals simultaneously is a difficult problem.

A review of the common excitation systems in use at the present time is presented in this chapter. The design and characteristics of each of the component parts are discussed, along with the methods of combining these parts to form an excitation system having the most desirable features. Methods of calculating and analyzing excitation system performance are also included.

I. DEFINITIONS

In discussing excitation systems, a number of terms are used, the meaning of which may not be entirely clear. The following definitions are proposed for inclusion in the new edition of the American Standards Association, Publication C42, "Definitions of Electrical Terms".

Excitation System—An excitation system is the source of field current for the excitation of a principal electric machine, including means for its control.

An excitation system, therefore, includes all of the equipment required to supply field current to excite a principal electric machine, which may be an a-c or d-c machine, and any equipment provided to regulate or control the amount of field current delivered.

Exciter Ceiling Voltage—Exciter ceiling voltage is the maximum voltage that may be attained by an exciter with specified conditions of load. For rotating exciters ceiling should be determined at rated speed and specified field temperature.

Nominal Exciter Ceiling Voltage—Nominal exciter ceiling voltage is the ceiling voltage of an exciter loaded with a resistor having an ohmic value equal to the resistance of the field winding

*A symposium of papers on excitation systems was presented before the AIEE in 1920 and gives details of equipment and practices in use at that time. See *AIEE Transactions*, Vol. 39, Part II, 1920, pp. 1551-1637.

to be excited. This resistance shall be determined at a temperature of:

- (a) 75C for field windings designed to operate at rating with a temperature rise of 60C or less
- (b) 100C for field windings designed to operate at rating with a temperature rise greater than 60C.

For rotating exciters the temperature of the exciter field winding should be considered to be 75C.

Rated-Load Field Voltage—Rated-load field voltage is the voltage required across the terminals of the field winding of an electric machine under rated continuous load conditions with the field winding at:

- (a) 75C for field windings designed to operate at rating with a temperature rise of 60C or less
- (b) 100C for field windings designed to operate at rating with a temperature rise greater than 60C.

No-Load Field Voltage—No-load field voltage is the voltage required across the terminals of the field winding of an electric machine under conditions of no load, rated speed and terminal voltage, and with the field winding at 25C.

In the definitions of rated-load and no-load field voltage, the terminals of the field winding are considered to be such that the brush drop is included in the voltage in the case of an a-c synchronous machine having slip rings.

Excitation System Stability—Excitation system stability is the ability of the excitation system to control the field voltage of the principal machine so that transient changes in the regulated voltage are effectively suppressed and sustained oscillations in the regulated voltage are not produced by the excitation system during steady-load conditions or following a change to a new steady-load condition.

Exciter Response—Exciter response is the rate of increase or decrease of the exciter voltage when a change in this voltage is demanded.

Main-Exciter Response Ratio—The main-exciter response ratio is the numerical value obtained when the response, in volts per second, is divided by the rated-load field voltage; which response, if maintained constant, would develop, in one-half second, the same excitation voltage-time area as attained by the actual exciter. The response is determined with no load on the exciter, with the exciter voltage initially equal to the rated-load field voltage, and then suddenly establishing circuit conditions which would be used to obtain nominal exciter ceiling voltage.

Note: For a rotating exciter, response should be determined at rated speed. This definition does not apply to main exciters having one or more series fields or to electronic exciters.

In using the per-unit system of designating exciter voltages, several choices are available from which to choose the unit.

First, the rated voltage of the exciter would appear to be the fundamental basis, but for system analysis it has very little utility.

Second, for specification purposes it has become standard through the adoption by the AIEE and ASA to use the rated-load field voltage as unity. It should be noted that rated-load field voltage is the voltage formerly referred to as "nominal slip-ring" or "nominal collector-ring" voltage.

Third, the exciter voltage necessary to circulate the field current required to produce rated voltage on the air-gap line of the main machine. For analytical purposes this is the one most generally used and is the one used in the analytical work in Chap. 6. Under steady-state conditions,

no saturation, and using this definition, exciter voltage, field current and synchronous internal voltage become equal.

Fourth, the slip-ring voltage necessary to produce rated voltage at no load or no-load field voltage is sometimes, but rather infrequently used. This definition includes the small amount of saturation present within the machine at no load.

Exciters for turbine generators of less than 10 000 kilowatts capacity are rated at 125 volts, and those for larger units are generally rated 250 volts. Some of the large units placed in service recently have exciters rated 375 volts. The vast majority of exciters in use with all types of synchronous machines greater than 10 000 kilowatts in capacity are rated 250 volts. On this rating the rated-load field voltage is of the order of 200 volts or 80 percent of the exciter rating. The exciter voltage required to produce the field current in the main machine corresponding to rated voltage on the air-gap line is usually about 90 volts or 36 percent of the exciter rating. Using this value as 1.0 per unit exciter voltage, the rated-load field voltage is approximately 2.2 per unit.

The nominal exciter ceiling voltage is defined above and can be interpreted as being the maximum voltage the exciter attains with all of the field-circuit resistance under control of the voltage regulator short circuited. On a 250-volt exciter, the ceiling voltage is usually about 300 to 330 volts, which is 120 to 132 percent of the exciter rated voltage, or 3.3 to 3.7 per unit. The relative values of these quantities are shown graphically in Fig. 2.

The construction of the response line in accordance with the definition for determining main-exciter response ratio is also included in Fig. 2. The curve *aed* is the actual

voltage-time curve of the exciter as determined under the specified conditions. Beginning at the rated-load field voltage, point *a*, the straight line *ac* is drawn so that the area under it, *abc*, during the one-half second interval from zero time is equal to the area under the actual voltage-time curve, *abde*, during the same interval. The response used in determining response ratio is the slope of the line *ac* in volts per second;

$$\frac{100 \text{ volts}}{0.5 \text{ second}} = 200 \text{ volts per second.}$$

The rated-load field voltage is 200 volts, and the response ratio, obtained by dividing the response by the rated-load field voltage, is 1.0. The work can also be done by expressing the voltages as per-unit values.

The half-second interval is chosen because it corresponds approximately to one-half period of the natural electro-mechanical oscillation of the average power system. It is the time during which the exciter must become active if it is to be effective in assisting to maintain system stability.

II. MAIN EXCITERS

The main exciter is a source of field current for the principal electric machine. Thus, any d-c machine that might be used to serve this purpose can be called a main exciter. Seldom are storage batteries used as main exciters. With a main generator of any appreciable size, the difficulties encountered in finding room for the battery, in maintaining the charge, and in keeping the battery in good operating condition are such as to make it impractical. Many other types of d-c machines have been developed

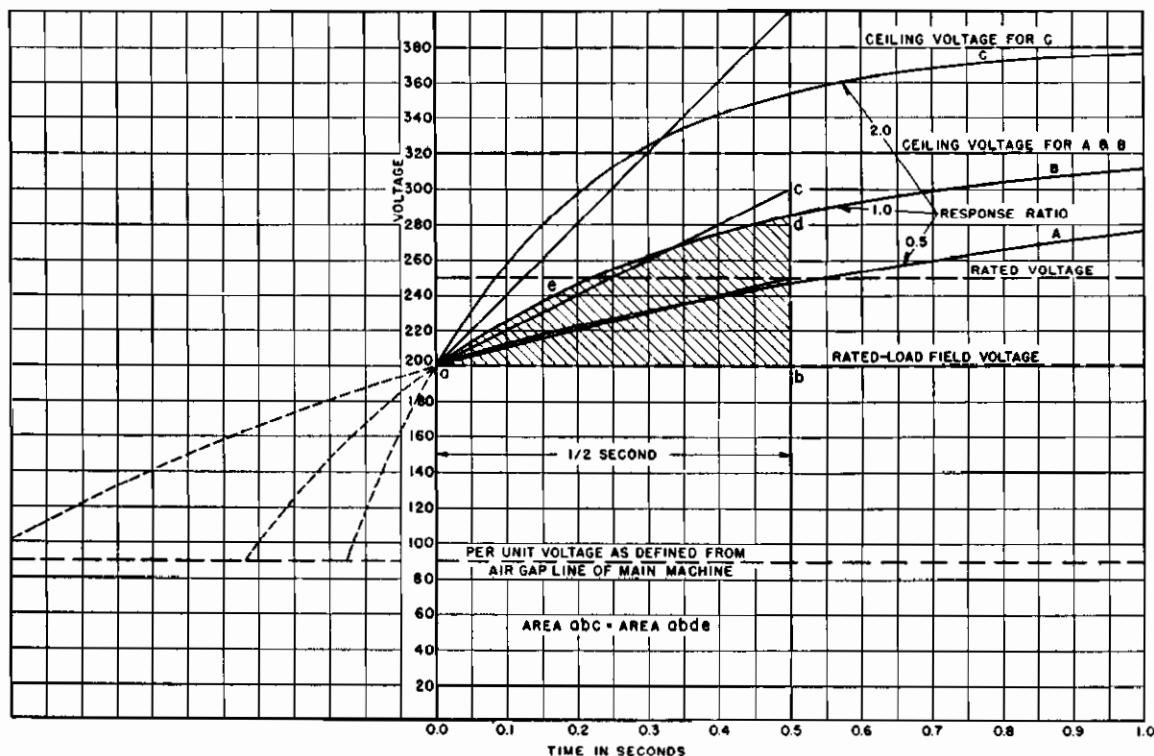

Fig. 2—Construction for determining main-exciter response ratio showing relative values of important quantities for 250-volt main exciter.

to a high degree of specialization for use as main exciters that offer many operating and maintenance advantages over a battery.

Main exciters, in general, can be grouped into two classifications; i.e., rotating and non-rotating d-c machines. The most common form of rotating main exciter is the more or less conventional d-c generator. The term "conventional" is used with reservation since a d-c generator built for the purpose of supplying excitation for a synchronous machine has incorporated in it many features to improve reliability and reduce maintenance not found on d-c generators used for other purposes. Aside from these special features, the theory of operation is the same as the conventional d-c generator. A new form of rotating exciter that has made its appearance in recent years is the main-exciter Rototrol. The Rototrol or rotating amplifier is very different in its operation from the conventional main exciter. The major static or non-rotating form of main exciter is the electronic exciter.

Each of these d-c machines, in regard to its application as a main exciter, is discussed in detail in the sections that follow.

1. Prime Movers for Main Exciters

Rotating main exciters are of either the direct-connected type or the separately-driven type. A direct-connected main exciter is one coupled directly to the shaft of the main generator and rotates at the same speed. A modification is the geared or shaft-driven exciter, driven through a gear by the shaft of the main generator. Problems of gear maintenance are introduced, but this enables the two machines to operate at different speeds. A separately-driven main exciter is usually driven by a motor, the complete unit being called an exciter m-g set, or it can be driven by some other form of prime mover such as a steam turbine or a hydraulic turbine.

Loss of excitation of an a-c generator generally means that it must be removed from service. Hence a reliable source of excitation is essential. If the main exciter should stop running while the main generator is still capable of operating, blame for the resultant outage would be placed on the main exciter. Considerable expense, therefore, can be justified to provide a reliable source of power to drive the main exciter. The type of drive accepted as reliable depends upon the type of synchronous machine being excited; that is, whether it be a generator or a synchronous condenser.

Exciter M-G Set—The exciter m-g set can be driven by a synchronous or induction motor. Direct-current motors have been used in some cases. The synchronous motor drive is undesirable, because of the possibility of transient disturbances on the motor supply system causing instability. Induction motors are ordinarily applied where the exciter m-g set is used. In any event, the motor must be specially designed to drive the main exciter through any form of system disturbance.

Power supply for the motor is, of course, important. The exciter m-g set might be classed as an essential auxiliary for operation of the generator, and may receive its power from the auxiliary power-supply system. Most essential auxiliaries have a dual power supply comprising a normal

and an emergency supply, and automatic quick-transfer to the emergency supply is provided in case of failure of the normal supply. In some cases, dual prime movers are used such as a motor and a steam turbine, the turbine taking over the drive when the motor power supply fails. The driving motor can be connected directly to the main generator terminals through an appropriate transformer. It is then subject to voltage disturbances on the main system.

The motor is apt to be subjected to voltage disturbances regardless of the source of its power supply, and it is necessary to construct the m-g set so that it can withstand these disturbances without affecting the excitation of the main a-c generator. The inertia constant of the m-g set and the pull-out torque of the motor must be high enough to assure that the speed of the set does not change appreciably or the motor stall during momentary voltage dips. The response ratio and ceiling voltage of the exciter must take into consideration any speed change that may occur. In arriving at values for these various factors, it is necessary that some time interval and voltage condition for the system disturbance be chosen. A common requirement is that the exciter m-g set be capable of delivering maximum forcing excitation to the generator field during a system disturbance when the motor voltage is 70 percent of normal for a period of one-half second. Based on this criterion, characteristics of the exciter m-g set have become fairly well standardized as follows:

Inertia constant of the entire m-g set, $H = 5.0$.

Pull-out torque of driving motor, $P_{max} = 500$ percent.

Response ratio of main exciter when operating at rated speed, $R = 2.0$.

Nominal exciter ceiling voltage when operating at rated speed, $E_{max} = 160$ percent.

When an exciter m-g set is used with a synchronous condenser, the logical source of power for the motor is the system that energizes the condenser. In this respect, the use of exciter m-g sets with synchronous condensers does not involve many complications.

Direct-Connected Exciter—The most reliable prime mover for the main exciter is the same prime mover that drives the a-c machine being excited. This was realized many years ago when main exciters were first coupled to the shafts of the generators. The reliability of this form of drive is obvious and no elaboration is necessary. However, in the case of high-speed turbine generators, early installations experienced trouble in operation of the d-c exciters at high speeds. These difficulties have been completely overcome by adequate design of the exciter, special features being included for operation at 3600 rpm. Direct connection of the main exciter is widely accepted in the utility industry.

2. Conventional Main Exciters

Conventional main exciters, in general, can be classified according to their method of excitation, being either self-excited or separately-excited. In the former the field winding or windings are connected across the terminals of the machine through variable resistors and in the latter the field windings with their resistors are connected to a source

If

- e_x = terminal voltage of the exciter and also the voltage across its field circuit
- i_f = field current per circuit in amperes
- r_f = total resistance of each field circuit in ohms
- ψ = flux linkages per circuit of the field winding in 10^{-8} lines-turns

then there exists for the field circuits the following equation:

$$e_x = r_f i_f + \frac{d\psi}{dt} \tag{1}$$

where each term is expressed in volts. This expression can be rewritten in the following form

$$\frac{d\psi}{dt} = e_x - r_f i_f \tag{2}$$

The flux linkages, ψ , can be regarded as made up of two components; first, those produced by the useful flux in the air gap and, second, those produced by the leakage fluxes. The first component is proportional to the no-load terminal voltage as this is the flux which produces that voltage. The designer can give the useful flux at any particular voltage or it can be obtained from the design constants of the machine. Multiplying this flux in 10^{-8} lines by the turns, N , linked by the flux, which is equal to the number of turns per pole times the number of poles per circuit, gives the total linkages due to this component. These linkages may be designated as $k_u e_x$, where, to be specific with respect to the particular voltage concerned, we may write

$$k_u = \frac{\left(\frac{\text{total useful flux linkages}}{\text{per pole at rated voltage}} \right) \left(\frac{\text{number of poles}}{\text{per circuit}} \right)}{\text{rated voltage}} \tag{3}$$

The leakage component is more complex as not all of the leakage flux cuts all of the turns. If there were no saturation effects in the pole pieces and yoke, the leakage fluxes would be proportional to the field current. If, however, the leakage fluxes are specified at some definite current such as that required to produce rated voltage at no load, then the leakage at higher currents will be less than proportional to the current and at lower currents will be more than proportional to that at the specified point. Inasmuch as the leakage flux is only about 10 percent of the useful flux, considerable error is permissible in the leakage component without affecting the result significantly. The leakage flux may be said to contribute the flux linkages $k_l i_f$ to the total. The coefficient k_l can be defined by requesting from the designer both the flux linkages per pole at rated voltage due to the useful flux and the total flux linkages per pole at rated voltage. The coefficient k_l is then

$$k_l = \frac{\left(\frac{\text{Total } \psi}{\text{per pole at rated voltage}} - \frac{\psi \text{ per pole due to useful flux}}{\text{at rated voltage}} \right) \left(\frac{\text{Number of poles}}{\text{per circuit}} \right)}{i_f \text{ at rated voltage}} \tag{4}$$

The total flux linkages per circuit are then

$$\psi = k_u e_x + k_l i_f \tag{5}$$

These quantities are illustrated in Fig. 5.

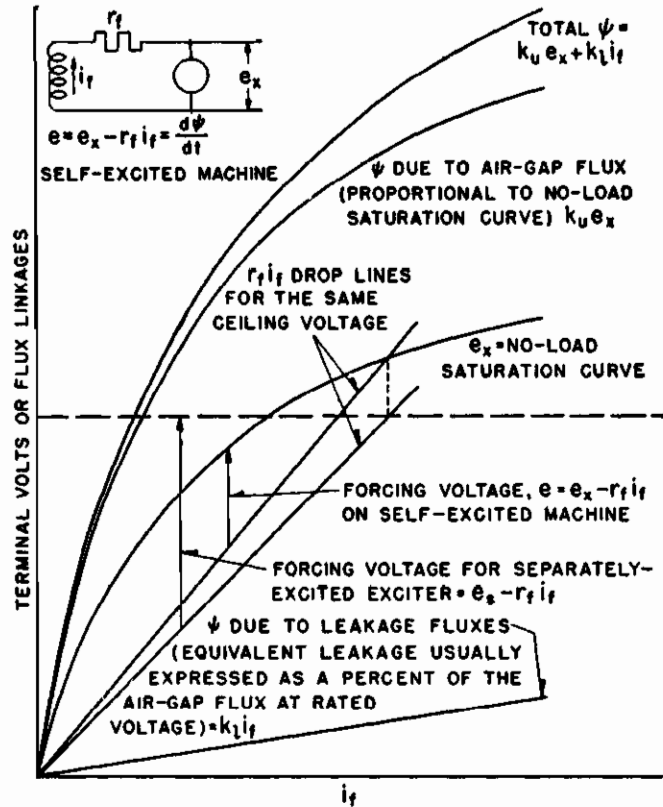

Fig. 5—Forcing voltages and flux linkages concerned in calculating response.

Equation (2) states that the time rate of rise of ψ is proportional at any instant to a forcing voltage which is equal to the vertical distance between the terminal-voltage curve and the straight-line curve of resistance drop at any given field current. It shows that the flux within the machine will increase so long as $(e_x - r_f i_f)$ is positive, that is, until the point of intersection of the two curves, as shown in Fig. 5, is attained. Beyond this point $(e_x - r_f i_f)$ becomes negative. If, for any reason, the flux within the machine extends beyond this point, it will decrease.

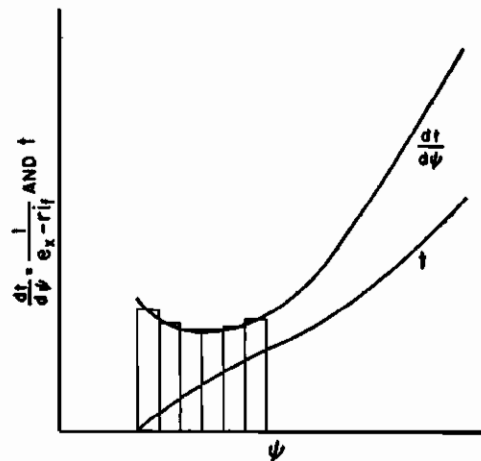

Fig. 6—Graphical determination of response of flux linkages ψ with time.

In other words, the intersection is a stable operating point.

Equation (2) can be transformed to

$$dt = \frac{d\psi}{e_x - r\dot{i}_t} \tag{6}$$

from which

$$t = \int_0^t dt = \int_{\psi_{\text{initial}}}^{\psi} \frac{d\psi}{e_x - r\dot{i}_t} \tag{7}$$

By choosing particular values of i_t from Fig. 5, it is possible to plot ψ as a function of $\frac{1}{e_x - r\dot{i}_t}$ or $\frac{dt}{d\psi}$ shown in Fig.

6. From Eq. (7) it can be seen that t can be obtained as a function of ψ by simply obtaining the area of the vertical strata of increments, starting from ψ corresponding to the starting value of e_x . After ψ is obtained, e_x can be plotted

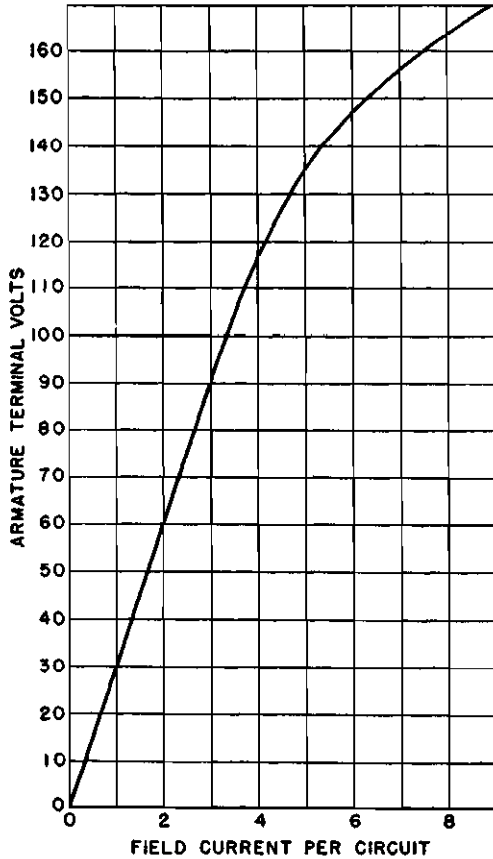

Fig. 7—Example for calculation of response of exciter.

167 kw, 125 volts, 1200 rpm, 6 poles
 Separately excited— $e_s = 125$ volts
 Three circuits—two poles per circuit
 Ceiling voltage—165 volts.
 i_t at ceiling voltage = 8.16 amperes per circuit
 Resistance per circuit = 15.3 ohms
 Two field windings = 6.8 ohms
 External resistance per circuit = 8.5 ohms
 Total external resistance = 2.8 ohms
 ψ per pole at 125 volts due to useful flux = 18
 Total ψ per pole at 125 volts = 20.3
 $k_a = \frac{18 \times 2}{125} = 0.288$ $k_1 = \frac{(20.3 - 18)2}{4.4} = 1.05$

as a function of time by taking corresponding points from Fig. 5. The simplest method for obtaining the area is to divide the region into a large number of increments and then sum them progressively on a recording adding machine.

If the machine is separately excited, the variable terminal voltage e_x in the expression for the forcing voltage should be replaced by the voltage e_s of the pilot exciter and the forcing voltage then becomes $(e_s - r\dot{i}_t)$, which is illustrated in Fig. 5. The difference in these forcing voltages shows why separately-excited exciters are usually faster in response.

When systematized, it is found that this calculation is quite simple, as will be illustrated by an example. Let it be desired to determine the exciter response for the separately-excited machine whose characteristics are given in Fig. 7. In Table 1, columns (1) and (2), tabulate the terminal voltage and field currents from Fig. 7. Columns (3) and (4) are simply steps in the determination of the total ψ of column (5). Columns (6) and (7) are likewise steps in the determination of $\frac{dt}{d\psi}$ of column (8). From this point a choice may be made of two procedures. If the graphical method is used, plot the value of $\frac{dt}{d\psi}$ from column (8) as ordinate against the value of ψ from column (5) as abscissa

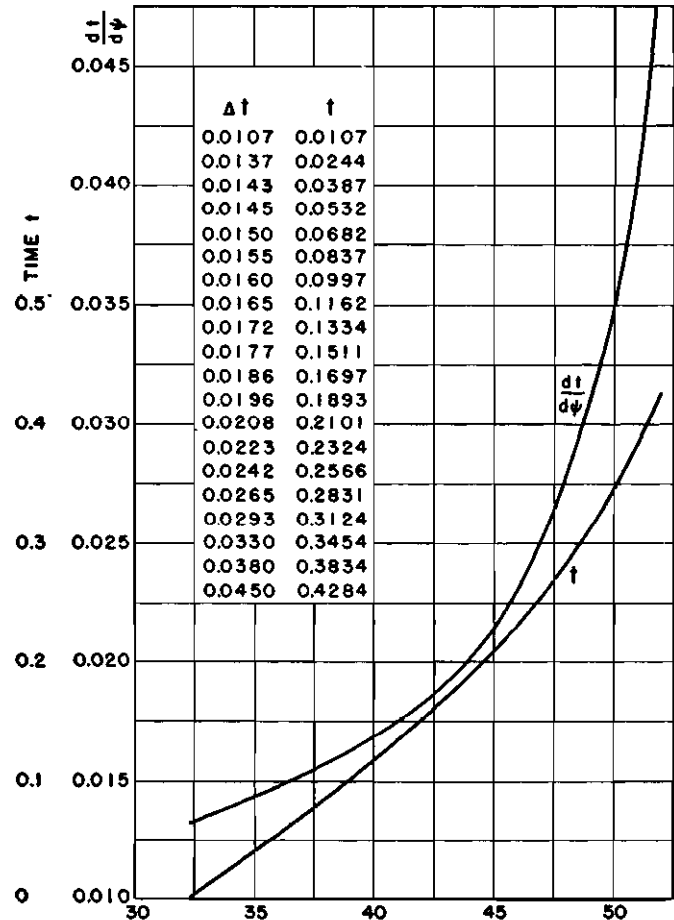

Fig. 8—Auxiliary curves for calculation of response for example given in Fig. 7.

TABLE 1

(1)	(2)	(3)	(4)	(5)	(6)	(7)	(8)	(9)	(10)	(11)	(12)
e_x	i_t	$k_u e_x$	$k_t i_t$	ψ	$r i_t$	$e_s - r i_t$	$\frac{1}{e_s - r i_t} = \frac{dt}{d\psi}$	$\Delta\psi$	Mean $\frac{dt}{d\psi}$	Δt	t in sec.
		$0.288 \times (1)$	$1.05 \times (2)$	(3) + (4)	$15.3 \times (2)$	$125 - (6)$	rec. of (7)	from (5)	from (8)	(9) \times (10)	$\Sigma(11)$
100	3.30	28.8	3.5	32.3	50.5	74.5	0.0134	0
110	3.70	31.7	3.9	35.6	56.6	68.4	0.0146	3.3	0.014	0.0462	0.0462
120	4.14	34.5	4.3	38.8	63.4	61.6	0.0162	3.2	0.0154	0.0493	0.0955
130	4.66	37.5	4.9	42.4	71.3	53.7	0.0186	3.6	0.0174	0.0626	0.1581
140	5.34	40.3	5.6	45.9	81.7	43.3	0.0231	3.5	0.0208	0.0728	0.2309
150	6.26	43.2	6.6	49.8	95.8	29.2	0.0342	3.9	0.0287	0.112	0.343
155	6.80	44.6	7.1	51.7	104.0	21.0	0.0476	1.9	0.0409	0.078	0.421
160	7.46	46.1	7.8	53.9	114.0	11.0	0.091	2.2	0.0693	0.152	0.573

giving the curve shown in Fig. 8. Time can then be determined by integrating this curve. One method of doing this is by means of the table constituting the insert of this figure. This is found by dividing ψ into increments of unit width, except for the first element for which $\Delta\psi$ is only 0.8. This is done to obtain convenient divisions. Increments of time Δt are enumerated in the first column. The second column represents time, the summation of the Δt column. On the other hand, the same integration can be accomplished in tabular form. Continuing in Table 1, column (9), the difference of successive values of ψ from column (5), constitutes the base of increments of area of curve $\frac{dt}{d\psi}$ in Fig. 8. Likewise, column (10), the mean of successive values of column (8), constitutes the mean of elementary areas. The product of these two values tabulated in column (11) is the increment of time. Column (12) is merely a progressive summation of (11) and gives actual time. By plotting column (1) against column (12), the response curve is obtained.

For higher speeds of response, the eddy currents produced in the solid yokes can retard the buildup of the flux. The extent to which this is effective is given by the curve

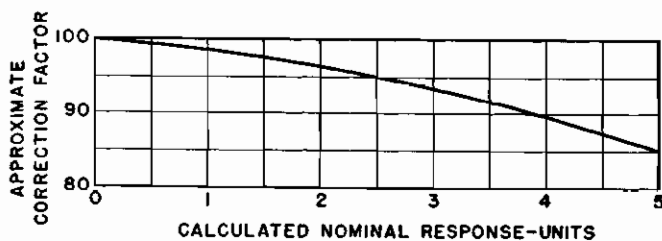

Fig. 9—Correction factor to be applied to calculated response to include effect of eddy currents, according to W. A. Lewis.¹

in Fig. 9 by W. A. Lewis¹. This curve supplies a correction to be applied to calculated responses.

Separately-excited exciters are usually, but not necessarily, faster in response than self-excited exciters. They do, however, have other advantages, such as being more stable at low voltages, voltages at which self-excited exciters may have a tendency to creep. Improvement in speed of response can be obtained by two general methods; (1) decreasing the time constant of the field circuit, and (2) increasing the pilot-exciter voltage in the case of separately-

excited exciters or the ceiling voltage in the case of self-excited exciters. The former is usually accomplished by paralleling the field circuits placing at the same time resistors in series to limit the current. Thus, if the parallels are doubled, the number of poles and likewise ψ per circuit are halved. It is necessary to add more resistance to the external circuit so that the resistance per circuit remains the same. In Eq. (7) the only change is that ψ is one-half and, therefore, the terminal voltage rises twice as fast.

4. Calculation of Response Under Loaded Conditions

Most of the cases for which the exciter response is desired are concerned with sudden changes, such as short circuits, in the armature circuit of the synchronous machine. Associated with these changes one usually finds that the field current of the alternator has increased a considerable amount, perhaps in excess of the armature current rating of the exciter. Because of the high inductance of the field circuit of the synchronous machine, the armature current of the exciter can usually be regarded as remaining substantially constant at this increased value during the period for which the response is desired.

When current flows in the armature, the phenomenon of armature reaction must be taken into consideration except for those machines that have a compensating winding. The function of the compensating winding, which is wound into the pole face of the field winding, is to annul the effect of the cross-magnetizing mmf of armature reaction. However, for machines without compensating windings, the mmf of armature reaction produces an mmf that varies linearly from the center of the pole piece, one side being positive and the other side negative. This effect is shown in Fig. 10 (a) in which MN represents the maximum magnetizing mmf at one pole edge and PQ represents the maximum demagnetizing mmf at the other pole edge. Fig. 10 (b) represents a section of the no-load saturation curve in which O represents the generated voltage on the vertical co-ordinate and the field mmf on the horizontal co-ordinate. If A and C are so laid off that OA and OC equal MN and PQ , respectively, from Fig. 10 (a), then because of the linearity of QN of Fig. 10 (a), the abscissa of Fig. 10 (b) between CA represents the mmf distribution along the pole face. Further, since the generated voltages are propor-

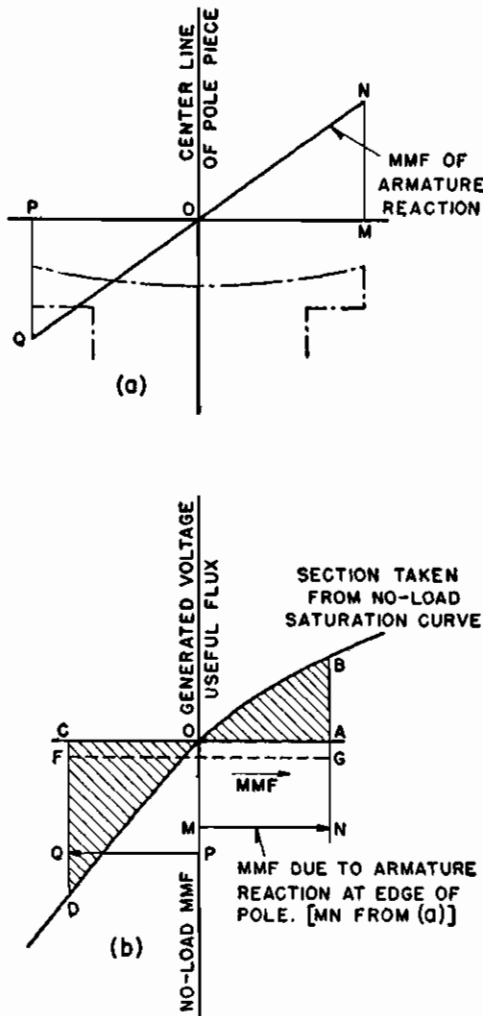

Fig. 10—Effect of armature reaction in reducing total flux across gap. (a) Shows distribution of armature mmf; (b) Section of no-load saturation curve.

tional to the air-gap fluxes, the section of no-load saturation curve shows the effect of the superposed armature mmf upon the density of air-gap flux across the pole. The higher mmf does not increase the flux on the right-hand side as much as the lower mmf decreases the flux on the left-hand side. As a result, the total flux and consequently the generated voltage are decreased from the value indicated by CA to that indicated by FG , which is obtained by integrating the area under the curve DOB and drawing FG so that the two triangular areas are equal. The extent to which the average flux or voltage is decreased can be indicated by a "distortion curve," such as shown by the dotted curve of Fig. 11. This effect is most pronounced in the region of the knee of the saturation curve as at both higher and lower field currents, there is a tendency to add on the one side of the pole just as much flux as is subtracted on the other. The terminal voltage is reduced still further by the armature resistance and brush drops, resulting in a load saturation curve for constant current, such as shown in Fig. 11.

From this same curve it can be seen that for a given field resistance line, the forcing voltage ($e_x - r_f i_f$) for a self-excited

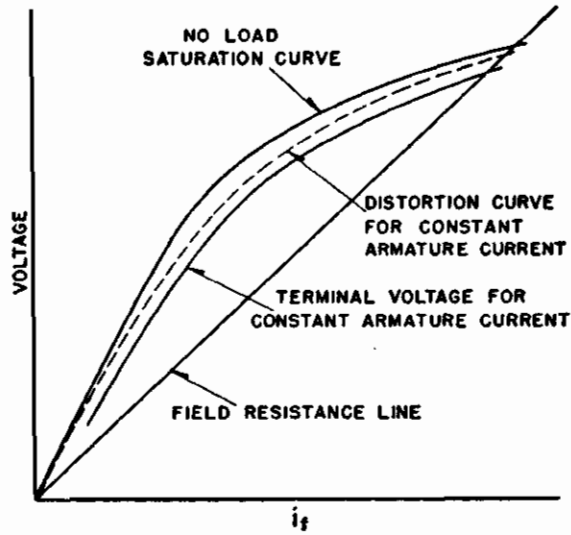

Fig. 11—Load saturation curves for exciter assuming constant armature current.

machine is very much smaller under load than under no load. In calculating the flux linkages in accordance with Eq. (5), the distortion curve should be used for e_x . Except for these two changes, the load response can be calculated in the same manner as the no load response.

For separately-excited exciters, the forcing voltage remains unaltered by the loading on the machine as it is independent of the terminal voltage. The armature resistance can be regarded as part of that of the main field winding. There remains only the distortion effect to consider which amounts to only several percent. For machines with compensating windings, this effect is negligible.

5. Effect of Differential Fields on Response

Differential windings are provided to reduce the exciter voltage to residual magnitude or below. They consist of a small number of turns wound on each pole, so connected that the mmf produced thereby is opposite to that of the main windings. Fig. 12 (a) shows schematically such an arrangement. If the differential windings are not opened when the regulator contacts close to produce field forcing, the differential circuit reduces the response of the exciter. The extent to which this is effective may be calculated as follows: Let

- a = number of parallel paths in the main winding.
- b = number of parallel paths in the differential winding.
- c = number of turns per pole of the main winding.
- d = number of turns per pole of the differential winding.
- N = total number of poles of exciter.
- i_m = current per circuit of main winding.
- i_d = current per circuit of differential winding.

The resistors R_m and R_d in series with the combined main and differential windings, respectively, may be included in the calculation by increasing the actual resistances in each of the main and differential circuits by aR_m and bR_d , respectively. With these increases the resistances of each of the main and differential circuits will be designated by the

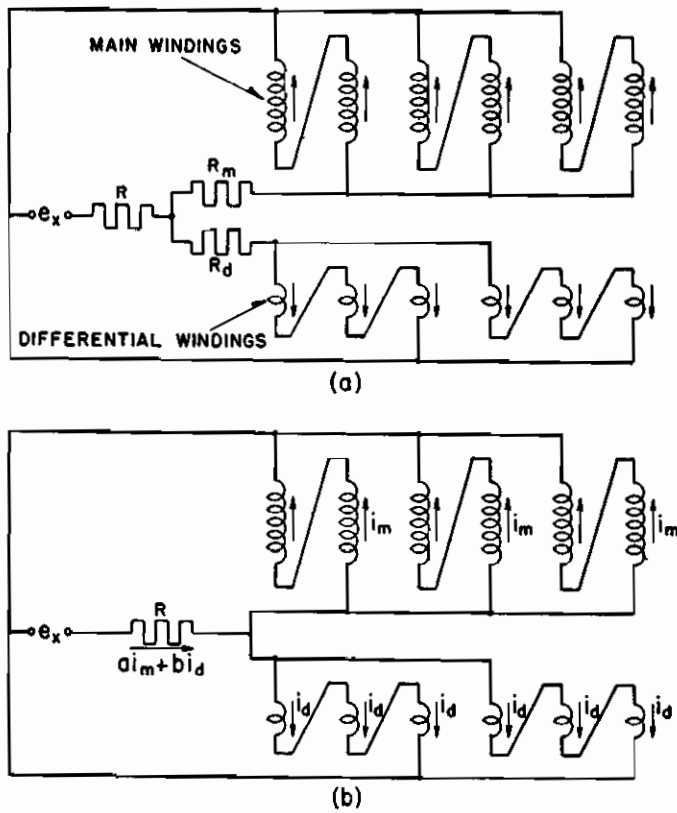

Fig. 12—Schematic diagram for main and differential windings.

symbols r_m and r_d , respectively. Referring to Fig. 12 (b) the following equations can be written

$$e_x = R(ai_m + bi_d) + r_m i_m + \frac{d\psi}{dt} \tag{8}$$

$$e_x = R(ai_m + bi_d) + r_d i_d + \frac{d\psi_d}{dt} \tag{9}$$

in which ψ and ψ_d are the flux linkages in each of the two respective circuits.

If all the field flux cuts all turns, then

$$\psi = \frac{N}{a} c \times (\text{flux per pole in } 10^{-8} \text{ lines})$$

$$\psi_d = \frac{N}{b} d \times (\text{flux per pole in } 10^{-8} \text{ lines})$$

or

$$\psi_d = \frac{ad\psi}{bc} \tag{10}$$

If it be assumed that the two windings be replaced by another winding having the same number of turns and circuit connections as the main windings, then the instantaneous mmf of this winding is the same as that of the combination if its current, i , is

$$i = i_m - \frac{d}{c} i_d$$

from which

$$i_m = i + \frac{d}{c} i_d \tag{11}$$

If (10) and (11) are inserted in (8) and (9), then

$$e_x = (Ra + r_m)(i + \frac{d}{c} i_d) + Rb i_d + \frac{d\psi}{dt} \tag{12}$$

$$e_x = Ra(i + \frac{d}{c} i_d) + (Rb + r_d) i_d + \frac{ad}{bc} \frac{d\psi}{dt} \tag{13}$$

By multiplying (13) by $\frac{bc}{ad}$, $\frac{d\psi}{dt}$ can be eliminated by subtracting from (12). The current i_d can then be solved in terms of i . Upon substituting the expression for i_d into (12) there is finally obtained that

$$\frac{1 - \frac{d}{c} \frac{r_m}{r_d}}{A} e_x = \frac{1 + R(\frac{a}{r_m} + \frac{b}{r_d})}{A} r_m i + \frac{d\psi}{dt} \tag{14}$$

in which

$$A = 1 - \frac{ad^2}{bc^2} \frac{1}{r_d} \left[r_m + \left(\frac{b^2 c^2}{ad^2} - a \right) R \right] \tag{15}$$

Equation 14 shows that the ordinary flux-linkage curve for the exciter and conventional method of calculation can be used if the coefficient of i be used as the resistance of each circuit, i be the current read from the saturation curve, and the voltage across each circuit be multiplied by the coefficient of e_x . In other words, the calculations should be carried out as though the differential winding were not present, except that instead of using the expression $(e_x - r_d i)$ to determine the forcing voltage, e_x should be multiplied by $\left(1 - \frac{d}{c} \frac{r_m}{r_d}\right) / A$, and r_t by $\left[1 + R\left(\frac{a}{r_m} + \frac{b}{r_d}\right)\right] / A$.

6. Three-Field Main Exciter

The three-field main exciter shown schematically in Fig. 13 is of conventional construction so far as mechanical details and armature winding are concerned, but it is built with three electrically independent shunt fields. Field 1 is connected in series with a variable resistance across the

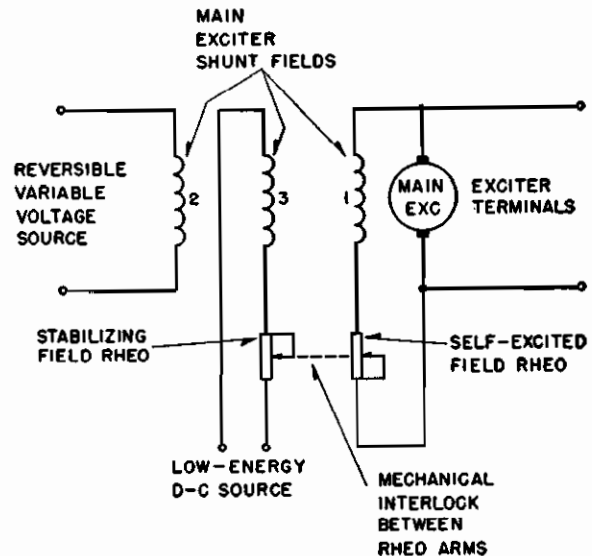

Fig. 13—Schematic diagram of three-field main exciter. Field 1 is self-excited and provides base excitation, field 2 is a separately-excited controlling field, and field 3 is a small-capacity battery-excited stabilizing field.

main terminals of the exciter and operates in the manner of the self-excited field discussed in Sec. 1. Field 1 provides the base excitation for the machine. Field 3 is a small separately-excited shunt field that obtains its energy from a station battery or any other source of substantially constant d-c voltage. It is capable of supplying 5 to 10 percent of the normal total excitation requirements of the main exciter, and its purpose is to provide exciter stability at low voltage output under hand control. Field 3 is used only when the exciter speed of response or range of voltage output makes it desirable. Field 2 is a shunt field that is excited from a reversible variable-voltage d-c source under control of a voltage regulator. This field also provides for stability of the exciter when the voltage regulation is under control of the voltage regulator.

Fields 1 and 3 have rheostats in their energizing circuits. These are usually motor-operated under manual control. The rheostat arms are mechanically connected together so that resistance is added in one field circuit as it is removed from the other. Thus, when the self-energized shunt field is carrying a high excitation current, the separately-excited field 3 carries a negligible current. The combined effect of fields 1 and 3 is shown in Fig. 14 and can be explained by assuming that the current in field 2 is zero. When the field rheostat is adjusted to give a voltage output greater than that represented by the distance Oc , all excitation is supplied by field 1, and the relation between the exciter terminal voltage and the total field ampere-turns is represented by the line ab . Operation in this region is the same as a self-excited exciter. If the resistance in the circuit of field 1 were increased to give a value of ampere-turns less than Od in Fig. 14, and if field 1 were the only field excited, the machine would be unstable as pointed out in Sec. 1.

To obtain a terminal voltage less than Oc , such as Of , the resistance in the self-excited field circuit would be increased to reduce the ampere-turns produced by that field to Oj . These ampere-turns would cause a generated voltage equal to Oh . However, at the same time the current in field 1 is reduced, the current in field 3 is increased, and the generated voltage due to field 3 being energized is represented by hf . The ampere-turns of the two fields and the generated voltages add so that the distance Of is the total terminal voltage. Since the current in field 3 is controlled by the amount of current in field 1 through the mechanical coupling of the field-rheostat arms, the total terminal voltage can be plotted as a function of the ampere-turns in field 1 alone and is represented by the curve $ekab$ in Fig. 14. If the field-resistance characteristic of the self-excited field is plotted on the same curve, there will always be a positive point of intersection between the resistance line and the saturation curve $ekab$ and stable operation can be obtained for any voltage greater than Oe . The voltage represented by Oe is usually less than 10 percent of the rated voltage of the exciter. Operation at smaller values would not ordinarily be necessary except in the case of a synchronous-condenser exciter. Smaller terminal voltages are obtained by holding the current in the self-excited field to zero and reducing the current in separately-excited field 3. Exciter polarity can be reversed by reversing both field circuits when the currents are zero and building up

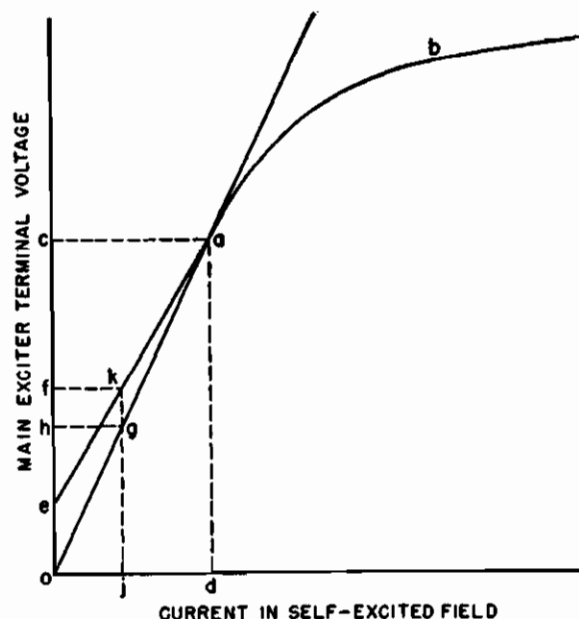

Fig. 14—Equivalent no-load saturation curve of three-field main exciter showing effect of stabilizing field 3. Field 2 is open-circuited.

in the opposite direction. Thus, manual control of voltage is possible over the complete range necessary.

When the voltage of the main exciter is under the control of a voltage regulator that varies the magnitude and polarity of voltage applied to the separately-excited field 2, the manually-operated field rheostat in field 1 circuit is set to provide some base amount of excitation. This setting is determined by the operator, but is generally high enough to supply sufficient field current to the a-c generator field to maintain steady-state stability. The current in field 3 is usually negligible with such a setting of the rheostat when the generator is carrying any load. The polarity and magnitude of the voltage applied to field 2 are then regulated so that the flux produced by field 2 either aids or opposes the flux produced by the base excitation in field 1, thus, either increasing or decreasing the exciter terminal voltage. Since the effect of field 1 is that of a conventional self-excited machine, a small amount of energy input to field 2 can control the output voltage over a wide range. The operation of the three-field main exciter is made stable by separate means for the two conditions of operation: by a separately-excited stabilizing field under manual control, and by the voltage regulator controlling the input to field 2 under regulator control.

The three-field main exciter has an advantage over the single-field separately-excited main exciter described in Sec. 1 in that control of the exciter terminal voltage is not completely lost if any trouble should occur in the separately-excited field circuit. The trouble might involve the variable-voltage source for field 2 or the voltage regulator that controls it, but even though the current in the field should become zero, the exciter will continue operating at a terminal voltage determined by the setting of the rheostat in the self-energized field circuit. The only effect on the a-c generator would be a change in its internal voltage which would cause a change in reactive loading of

the machine. Under similar circumstances of failure with the single-field exciter, the source of excitation for the a-c generator field would be lost and a shut-down of the unit would be necessary.

7. Calculation of Response of Three-Field Main Exciter

A method of calculating the response of a single-field exciter is given in Sec. 2. The method uses step-by-step integration to take into account the saturated condition of the exciter. If additional fields are present, damping currents flow in those fields during voltage changes. Their effect is to reduce the rate of change of flux in the exciter iron paths. The following analysis presents a means of replacing the assembly of several fields with one equivalent field so that the response can be calculated.

The specific fields involved in the three-field main exciter are the self-excited field 1, the battery-excited field 3, and the separately-excited field 2 as shown in Fig. 13. The three fields are wound to form a single element to be mounted on the field pole, so that the mutual coupling is high and can be assumed to be 100 percent with small error. Also, the same leakage coefficient can be applied to each of the fields. In the following symbols the subscript indicates the particular field to which the symbol applies. Thus, N_1 is the turns per pole of field 1, N_2 the turns per pole of field 2, etc.

P = Number of poles, assumed to be connected in series.

N = Number of turns per pole in the field winding.

ϕ' = Total useful flux per pole in Maxwells times 10^8 .

ϕ_0 = Initial useful flux per pole in Maxwells times 10^8 .

ϕ = Change in flux per pole = $\phi' - \phi_0$.

i' = Total amperes in field circuit.

i_0 = Initial amperes in field circuit.

i = Change in amperes in field winding = $i' - i_0$.

L = Inductance of field winding in Henrys.

K = Flux proportionality constant

$$= \frac{\text{Maxwells} \times 10^8 \text{ per pole}}{\text{Ampere turns per pole}}$$

λ = Flux leakage factor = $1 + \frac{\text{leakage flux}}{\text{useful flux}}$

c = Voltage proportionality constant

$$= \frac{\text{Maxwells} \times 10^8 \text{ per pole}}{\text{terminal volts}}$$

R = Resistance of the complete field circuit, ohms.

t = Time constant of complete field circuit, seconds.

E_t' = Terminal voltage applied to field 1.

E_{t0} = Initial value of terminal voltage.

E_t = Change in terminal voltage = $E_t' - E_{t0}$.

E_2 = Voltage applied to field 2.

E_{20} = Initial value of voltage applied to field 2.

E_2 = Change in voltage applied to field 2.

E_3 = Fixed voltage applied to field 3.

ρ = Differential operator $\frac{d}{dt}$.

The initial or steady-state value of total useful flux per pole is

$$\phi_0 = K(N_1 i_{10} + N_2 i_{20} + N_3 i_{30}). \quad (16)$$

When the field currents are changed to force an increase in

terminal voltage, the total useful flux at any later instant of time is

$$\phi' = K(N_1 i_1' + N_2 i_2' + N_3 i_3'). \quad (17)$$

The change in total flux per pole is the difference between these two values,

$$\phi = \phi' - \phi_0 = K(N_1 i_1 + N_2 i_2 + N_3 i_3). \quad (18)$$

The basic formula for the self-inductance of any of the field circuits is

$$L = \frac{N\phi 10^{-8}}{i} \text{ henrys,}$$

and since the flux is expressed as Maxwells per pole times 10^8 , the self-inductance of the circuit of field 1 becomes

$$L_1 = \frac{P\phi N_1 \lambda}{i_1} = PKN_1^2 \lambda. \quad (19)$$

The time constant of the field circuit is the total self-inductance divided by the total resistance,

$$t_1 = \frac{L_1}{R_1} = \frac{PKN_1^2 \lambda}{R_1}. \quad (20)$$

Equations similar to Eq. (19) can be written for self-inductances L_2 and L_3 and similar to Eq. (20) for time constants t_2 and t_3 .

The voltage applied to each of the field circuits is absorbed in Ri drop in the circuit resistance and $N \frac{d\phi}{dt}$ drop in the circuit inductance. The voltage equations at any instant of time are

$$E_t' = c\phi' = R_1 i_1' + N_1 \lambda P \rho \phi' \quad (21)$$

$$E_2 = R_2 i_2 + N_2 \lambda P \rho \phi' \quad (22)$$

$$E_3 = R_3 i_3 + N_3 \lambda P \rho \phi'. \quad (23)$$

During the initial steady-state conditions, when the total useful flux is constant and $\rho\phi_0 = 0$,

$$E_{t0} = c\phi_0 = R_1 i_{10} + N_1 \lambda P \rho \phi_0 \quad (24)$$

$$E_{20} = R_2 i_{20} + N_2 \lambda P \rho \phi_0 \quad (25)$$

$$E_{30} = R_3 i_{30} + N_3 \lambda P \rho \phi_0. \quad (26)$$

Subtracting the two sets of voltage equations, a set in terms of changes from steady-state conditions is obtained. Since the voltage E_3 is supplied from a constant-potential source, $E_3' - E_{30} = 0$.

$$c\phi = R_1 i_1 + N_1 \lambda P \rho \phi \quad (27)$$

$$E_2 = R_2 i_2 + N_2 \lambda P \rho \phi \quad (28)$$

$$0 = R_3 i_3 + N_3 \lambda P \rho \phi \quad (29)$$

If Eqs. (27), (28), and (29) are multiplied by $\frac{KN_1}{R_1}$, $\frac{KN_2}{R_2}$,

and $\frac{KN_3}{R_3}$, respectively, and added, the result obtained after substituting from Eqs. (18) and (20) is

$$\frac{t_1}{PN_1 \lambda} c\phi + \frac{t_2}{PN_2 \lambda} E_2 = \phi + (t_1 + t_2 + t_3) \rho \phi. \quad (30)$$

Rearranging the terms in Eq. (30);

$$\frac{t_2}{PN_2 \lambda} E_2 = \left[\left(1 - \frac{ct_1}{PN_1 \lambda} \right) + (t_1 + t_2 + t_3) \rho \right] \phi. \quad (31)$$

When solved, Eq. (31) expresses ϕ and hence the terminal voltage as a function of time if saturation and the consequent change in constants are neglected.

The three fields on the exciter can be assumed to be replaced with a single equivalent self-excited field as shown in Fig. 15. The quantities referring to the equivalent

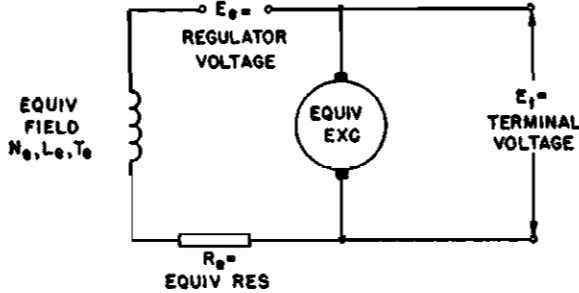

Fig. 15—Self-excited single-field equivalent of three-field main exciter.

field are designated by the subscript e . The field has applied to it a voltage equal to the terminal voltage $c\phi'$ plus an equivalent voltage E_e' supplied by the regulator. During steady-state conditions,

$$E_{e0} + c\phi_0 = R_e i_{e0} + N_e \lambda P \rho \phi_0. \quad (32)$$

At any instant of time,

$$E_e' + c\phi' = R_e i_e' + N_e \lambda P \rho \phi'. \quad (33)$$

Subtracting Eq. (32) from (33)

$$E_e + c\phi = R_e i_e + N_e \lambda P \rho \phi. \quad (34)$$

Using the relations

$$\phi = KN_e i_e \quad (35)$$

$$L_e = \frac{P\phi N_e \lambda}{i_e} = PKN_e^2 \lambda \quad (36)$$

$$t_e = \frac{PKN_e^2 \lambda}{R_e} \quad (37)$$

Eq. (34) reduces to

$$\frac{t_e}{PN_e \lambda} E_e = \left[\left(1 - \frac{ct_e}{PN_e \lambda} \right) + t_e \rho \right] \phi. \quad (38)$$

Equation (38) is of the same form as Eq. (31), and by comparing similar terms, it is derived that

$$t_e = t_1 + t_2 + t_3 \quad (39)$$

$$N_e = \frac{N_1 t_1}{t_e} \quad (40)$$

The self-inductance of the equivalent field is given by Eq. (36), and the resistance is

$$R_e = \frac{L_e}{t_e} \quad (41)$$

The applied regulator voltage is

$$E_e = \frac{t_2 N_e}{t_e N_2} E_2.$$

Eliminating $\frac{N_e}{t_e}$ by using Eq. (40)

$$E_e = \frac{t_2 N_1}{t_1 N_2} E_2. \quad (42)$$

Equations (38) and (31) can be solved only if saturation is neglected. However, for a small interval of time, it can be assumed that the machine constants do not change, and the change in flux calculated by either equation will be the same. If at the end of the first time interval, the machine constants are appropriately adjusted to new values applicable to the next small interval of time, the flux change can be calculated for the second interval and will be the same by either equation. Thus, the flux rise calculated from the equation for the single equivalent field by using the normal step-by-step methods that take into account saturation will be the same as the actual flux rise with the assembly of several fields. The various time constants for the machine in the unsaturated condition may be used to determine the constants of the equivalent field.

The above equations can be generalized to the case of a machine having any number of the three types of fields considered. Letting t_r , E_r , and N_r refer to all coils to which regulator voltages are applied, and t_s and N_s refer to all coils which are self excited, Eq. (31) in the general form becomes

$$\sum \frac{t_r E_r}{PN_r \lambda} = \left[\left(1 - c \sum \frac{t_s}{PN_s \lambda} \right) + \rho \Sigma t \right] \phi \quad (43)$$

where Σt = sum of time constants of coils of all types. The sum of the time constants should also include a value for the frame slab, which acts as a short-circuited turn, and eddy currents in the slab cause a delay in the flux rise. For d-c machines of the size used as main exciters, the frame-slab time constant may approach 0.2 second.

The constants of the equivalent self-excited field are determined from the following:

$$t_e = \Sigma t \quad (44)$$

$$N_e = \frac{t_e}{\sum \frac{t_s}{N_s}} \quad (45)$$

L_e is determined by Eq. (36)

$$R_e = \frac{L_e}{t_e} \quad (46)$$

and the regulator voltage to be applied

$$E_e = \frac{N_e}{t_e} \sum \frac{t_r}{N_r} E_r. \quad (47)$$

If no self-excited fields are present in the machine, the only requirements to be satisfied are given by Eqs. (44) and (47). Any value of N_e can be used provided the appropriate value of R_e is calculated from Eqs. (36) and (46). When no self-excited fields are present, the equivalent field is not self-excited and has applied to it only the regulator voltage.

If no regulator-controlled fields are present, the requirements to be met are given by Eqs. (44), (45), (46), and

(47), and the equivalent field is a self-excited field with no regulator voltage applied.

Using this equivalent single-field representation of the multiple-field main exciter, the voltage response can be calculated by the step-by-step method of Sec. 2. The voltage E is determined by the source of voltage under regulator control. For example, if the regulated field is a self-excited field, the voltage E becomes equal to the exciter terminal voltage at each instant of time.

8. Main-Exciter Rototrol

The most recent development in the field of rotating main exciters is the adaptation of the *Rototrol rotating amplifier* as a main exciter. Any generator is in fact a "rotating amplifier" in that a small amount of energy input to the field is amplified to a large energy output at the generator terminals. However, the name rotating amplifier has been specifically applied to a form of rotating machine possessing an unusually large amplification factor. In such machines, the change in input energy to the field is a small fraction of the resulting change in energy output of the armature. In the ordinary d-c generator, the change in field energy required to produce 100-percent change in output energy is usually within the range of 1 percent to 3 percent of the machine rating. Thus, the amplification factor might be between 30 and 100. In the case of the Rototrol, the amplification factor can exceed 10^6 depending upon the design of the machine.

The main-exciter Rototrol is not adaptable at present to use with generators operating at less than 1200 rpm. The principal field of application is with 3600-rpm turbine generators. The two-stage main-exciter Rototrol can be built with sufficient capacity to supply the excitation requirements of the largest 3600-rpm generator, but when used with 1800- or 1200-rpm generators, the maximum rating of generator is restricted. In any event, the Rototrol is direct-connected to the generator shaft.

The slower the speed of a generator, the larger the physical size. For a given voltage output, the reduction in speed is compensated by an increase in the total flux, requiring a larger volume of iron to maintain the same flux density.

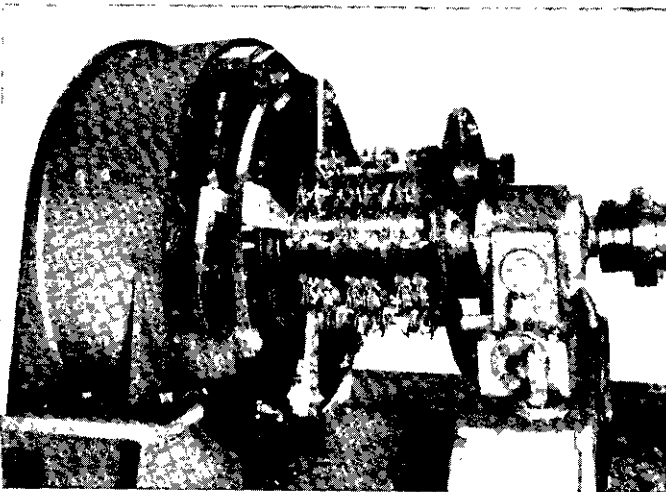

Fig. 16—A 210-kw, 250-volt, 4-pole main-exciter Rototrol for direct-connection to generator shaft at 3600 rpm.

The excitation requirements, therefore, are greater for slow-speed generators. The main-exciter Rototrol has not been built in capacities large enough to supply the excitation requirements of large slow-speed a-c generators. Furthermore, as the Rototrol rated speed is decreased, its excitation requirements also increase and a larger controlling energy is required. The combination of these factors has largely restricted the use of the main-exciter Rototrol to direct-connection with 3600-rpm turbine generators.

A 210-kw, 250-volt, 3600-rpm main-exciter Rototrol is illustrated in Fig. 16, and to all outward appearances it is a conventional type of d-c machine. The mechanical details such as the enclosure, brush holders, commutator, etc., are of conventional 3600-rpm exciter construction, but the electrical connections are quite different. The armature winding is of the lap form but has no cross connections, and there are a number of specially-connected field windings to provide the high amplification factor.

A detailed discussion of the theory of operation of the Rototrol is beyond the scope of this chapter, and can be found in the References. The discussion here will be confined to a description of the operating principle as it applies to use of the Rototrol in excitation systems.

A schematic diagram of the main-exciter Rototrol is shown in Fig. 17 (a), and the equivalent schematic diagram is shown in Fig. 17 (b). The Rototrol can be built with one or more stages of amplification, and the main exciter Rototrol is of the two-stage type. The field connected between terminals F3-F4 is called the control field, and windings appear on only the two south poles, 1 and 3. The circuit between terminals F5-F6 energizes a field similar to the control field, and it also appears on only the two south poles. This field operates in the same manner as the control field in controlling the Rototrol terminal voltage but it is called the limits field. The control field is energized by the voltage regulator and normally has control of the voltage output. However, the limits field is energized by devices that restrict the maximum or minimum voltage output, so that the limits field can, under certain conditions, overcome the effect of the control field. The output terminals are L1-L2, and it should be noted that the circuit between the brushes of like polarity energizes additional field windings that are compensating and forcing fields and also serve as series fields. The windings energized by the circuit between terminals F1-F2 are shunt-field windings used for tuning purposes as discussed later. As far as external circuits are concerned, the main-exciter Rototrol can be represented as shown in Fig. 17 (c): the control field is energized by some exciter-voltage controlling device, the limits field is energized by a device for limiting the maximum or minimum output or both, and the line terminals supply voltage to the load in series with the series field.

The operation of a conventional self-excited d-c generator is unstable when the field-resistance line coincides with the air-gap line of the saturation curve as shown in Sec. 1. Although this characteristic is undesirable in the self-excited generator, it is an important part of the Rototrol principle. Reasoning identical to that in Sec. 1 can be applied to a series-excited generator where the self-excited winding is in series with the load and both the load and the field can be considered as a shunt across the armature.

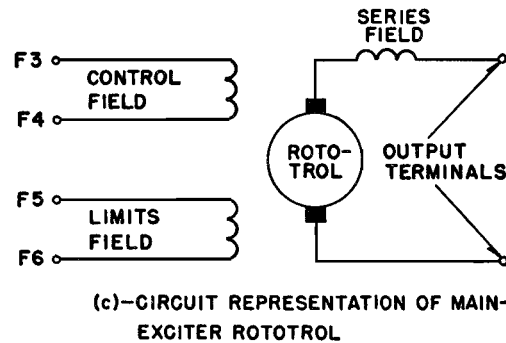
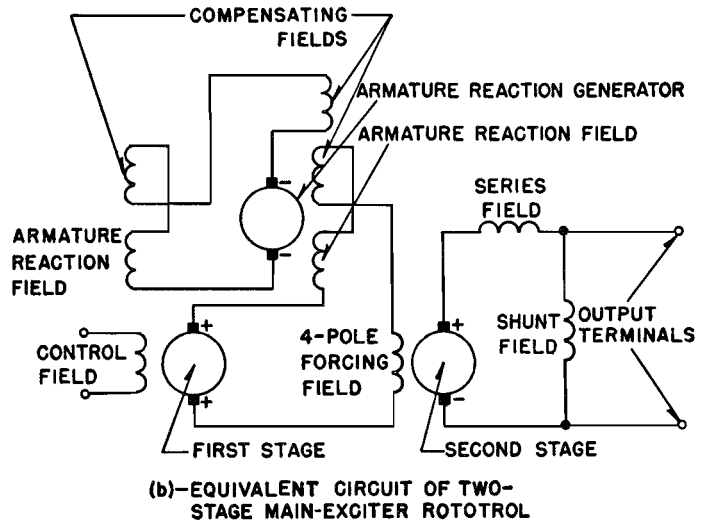
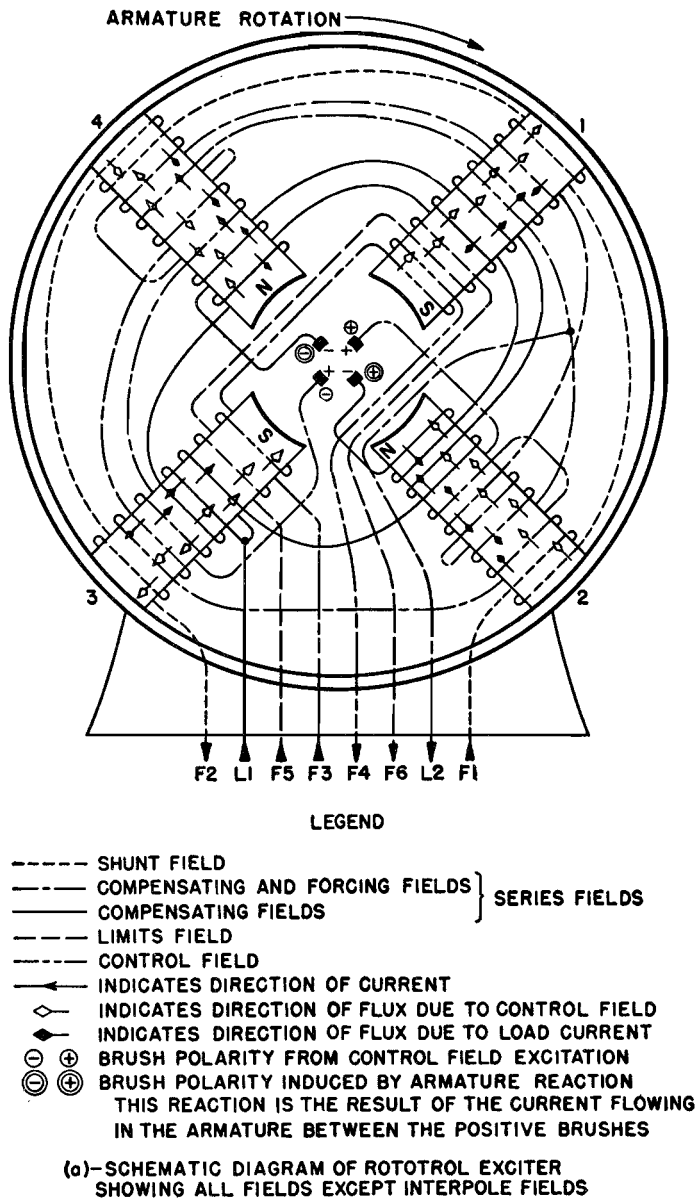

Fig. 17—Two-stage main-exciter Rototrol, complete schematic diagram and equivalent representations.

The series-field current then is directly proportional to the armature voltage in the same way as the shunt-field current in the self-excited shunt-wound machine.

The Rototrol is operated on the straight portion of its saturation curve and the adjustments necessary to meet this condition are termed tuning of the Rototrol. This is usually done by adjusting the resistance of the load or an adjustable resistance in series with the load, but can also be done by varying the air gap between the field poles and the rotor surface, which shifts the position of the air-gap line. Thus, the series-field circuit is tuned so that the resistance line of the circuit coincides with the air-gap line. Exact coincidence of the resistance line with the air-gap line cannot always be obtained by these two means so a small-capacity shunt field is provided to serve as a vernier adjustment. The resistance of the shunt-field circuit is adjusted to change the position of the terminal voltage-series-field current relation to tune the machine perfectly.

It is particularly significant that under steady-state conditions, the self-excited field of the Rototrol furnishes all of the ampere-turns required to generate the terminal voltage. However, the control field forces the change in ampere-turns required to stabilize the machine or to change and establish the terminal voltage required for a new load condition. The ampere-turns of the self-excited field and those of the control and limits fields are superimposed, and the algebraic sum of the ampere-turns on all of the Rototrol fields determines the terminal voltage.

9. Operating Principle of the Main-Exciter Rototrol

The fundamental principle by which a small amount of energy in the control field forces a large change in Rototrol output is that of unbalancing the ampere-turns on two poles of like polarity; in this case, two south poles. A current in a given direction in the control field will weaken

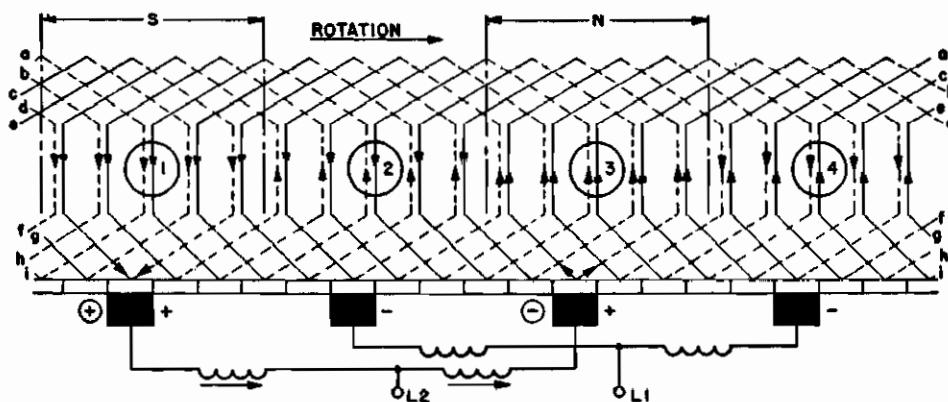

(a) SIMPLIFIED WINDING-DEVELOPMENT DIAGRAM OF TWO-STAGE ROTOTROL SHOWING CURRENT FLOW WITH CONTROL FIELD ENERGIZED

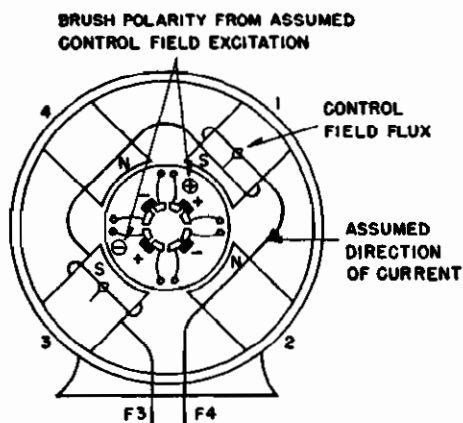

(b) - ROTOTROL EXCITER CONTROL FIELD WINDING

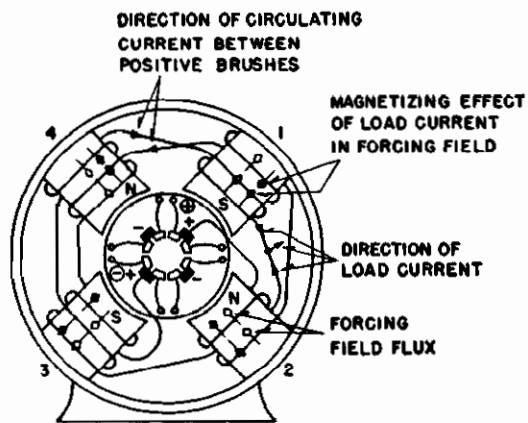

(c) ROTOTROL EXCITER FORCING FIELDS CONNECTED IN SERIES BETWEEN THE POSITIVE BRUSHES

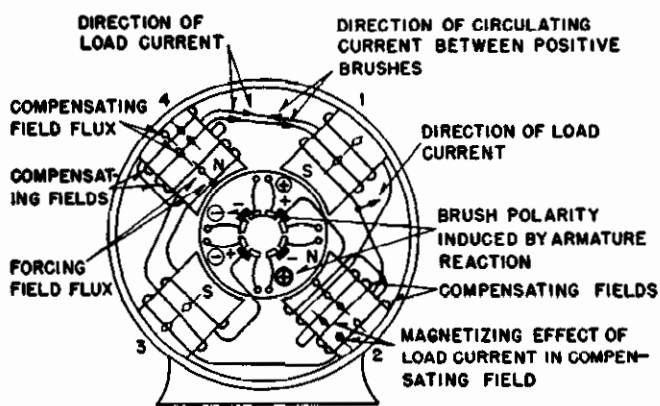

(d) - ROTOTROL EXCITER FORCING AND COMPENSATING FIELDS CONNECTED IN SERIES BETWEEN THE POSITIVE BRUSHES

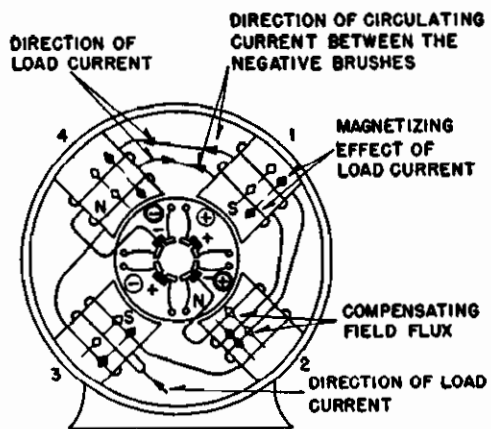

(e) ROTOTROL EXCITER COMPENSATING FIELDS CONNECTED IN SERIES BETWEEN THE NEGATIVE BRUSHES

—●— FLUX DUE TO LOAD CURRENT
 —○— FLUX DUE TO CONTROL FIELD BEING ENERGIZED

Fig. 18—Principle of operation of two-stage Rototrol.

one south pole and strengthen the other, and by virtue of the form of the armature winding, causes a difference in polarity between two brushes of like polarity. Current-direction arrows and corresponding flux-direction arrows are shown in Fig. 17 (a), and the operation can be understood best by describing the sequence of events for a given operating condition.

A current is shown flowing in the control field in Fig. 18 (b). The current is in a direction to cause an increase in the terminal voltage of the Rototrol and produces fluxes as shown by the flux arrows to strengthen south pole 1 and weaken south pole 3. Reversing the polarity of the voltage applied to the control field would reverse the effect and cause a decrease in terminal voltage. The resulting unbalance of the south-pole fluxes causes a phenomenon that is suppressed in the usual d-c generator; and that is the unbalance of voltage generated in the armature when the magnetic flux densities in the field poles are unequal. The effect of the unbalanced south poles on the armature winding can be analyzed by assuming the unbalanced fluxes are the only ones present in the machine.

The winding-development diagram of Fig. 18 (a) is drawn for the control-field flux in the direction shown in Fig. 18 (b). So far as the control-field flux is concerned, pole 1 is a south pole and pole 3 is a north pole; thus, the flux direction under pole 1 is out of the paper and under pole 3 is into the paper in Fig. 18 (a). For clockwise armature rotation, the conductor moves under poles 1, 2, 3, and 4 in that order, so the current directions in the armature conductors are as shown. The result is that the positive brush under pole 1 is raised to a higher potential than the positive brush under pole 3. The relative polarities of the two positive brushes are, therefore, as indicated by the encircled polarity marks. Further analysis shows that the positive brush of higher potential is always under the south control-field pole for the conditions of Fig. 18.

The potential difference between the two positive brushes is used to energize another special field called the forcing field, as shown in Fig. 18 (c). For control-field current in the direction shown, the fluxes produced by the forcing-field windings are in a direction to increase the flux densities in all four poles as shown by the open-headed flux arrows, which is in the direction to increase the terminal voltage of the machine. With the opposite control-field polarity, the forcing-field mmf's decrease the flux densities.

The forcing-field current also flows through the armature winding as shown in Fig. 18 (a). The two conductors in a common slot under poles 2 and 4 carry currents in opposing directions. The conductors under poles 1 and 3, however, carry currents in a common direction. Thus, an armature reaction is developed which is in the direction to weaken north pole 2 and strengthen north pole 4. The effect is similar to that caused by current flow in the control field, except that the unbalance in generated voltage appears between the two negative brushes with polarities as shown by the encircled marks in Fig. 18 (d). The resulting current flow between the two negative brushes would cause an armature reaction in opposition to the control field, greatly reducing its effectiveness if compensation were not provided in some way. The compensating windings in series with the forcing fields in Fig. 18 (d) oppose the armature

reaction caused by current between the positive brushes, holding to a minimum the voltage difference between the negative brushes and minimizing the armature reaction that would oppose the control field.

A group of compensating fields are also connected in series in the circuit between the negative brushes, and serve a purpose similar to that of the compensating fields between the positive brushes. These are shown in Fig. 18 (e).

All of these currents and fluxes are summarized in Fig. 17 (a), which shows all of the field windings and the current and flux arrows for the assumed condition. Tracing the circuit of the load current reveals that the load current must flow through the forcing and compensating fields. The coils are wound on the field poles in such a direction that the load current cancels so far as any magnetizing effect is concerned, while the magnetizing effects of the unbalance currents add. This is verified in the circuits of Figs. 18 (c), (d), and (e).

In addition to the field windings described above, a set of commutating-pole windings are included in the Rototrol. These windings produce the proper mmf in the commutating poles to assist commutation of the current in the armature.

The overall effect of current in the control field is shown in Fig. 17 (b), the equivalent circuit of the two-stage main-exciter Rototrol. The Rototrol is represented as three separate generators; two of them are two-pole machines and the third is a four-pole machine. The difference in potential between the two positive brushes caused by current in the control field is represented as a two-pole generator excited by the control field and is the first stage of amplification in the Rototrol. The output of this machine is fed into the field of the four-pole generator which is the second stage of amplification. The four-pole field windings are the forcing fields of the Rototrol. Current flowing in the first-stage machine sets up an armature reaction represented by a two-pole armature-reaction generator. The armature reaction is represented by a field exciting this generator and the compensation for armature reaction between the positive brushes is another field on this same machine. The mmf's produced in the armature-reaction and compensating fields are in opposition.

The armature reaction establishes a potential difference between the negative brushes as shown, and the current flowing between these brushes energizes additional compensating windings on all four poles. Two of these windings appear as compensating windings on the armature-reaction generator since they further compensate for the armature reaction produced by the current between the positive brushes. The remaining two compensating windings compensate for the armature reaction caused by the current flowing between the negative brushes, this armature reaction being in opposition to the control field exciting the first stage.

10. Series-Field Effect in Main-Exciter Rototrol

The definition of main-exciter response ratio given in Part I does not apply to main exciters having series fields. Thus, the response ratio of the main-exciter Rototrol cannot be stated in the conventional manner. As stated in Sec. 7, the series field of the Rototrol supplies all of the

ampere-turns necessary to generate the terminal voltage under steady-state conditions. The response-ratio definition also states that the test for voltage response should be made under conditions of no load on the exciter, which would seriously hamper the rate of voltage build-up in the Rototrol, because there would be no mmf produced by the series field.

As shown in Chap. 6, Part II, a short circuit at the terminals of an a-c generator induces a large direct current

in the generator field winding. The induced current is in the same direction as the current already flowing in the field circuit and serves to maintain constant flux linkages with the field winding. This occurs when the generator voltage is low, and if the induced current were sustained at its initial value, the internal voltage of the generator would be at a high value when the fault is removed. The function of a quick-response excitation system is to increase the exciter voltage as rapidly as possible under such conditions, in order to keep the field current at as high a value as possible. The same effect takes place, although to a smaller extent, when a load is suddenly applied to the generator terminals. Removal of a fault or sudden reduction of the load causes an induced current in the opposite direction due to removal of the armature demagnetizing effect. Thus, a current of appropriate magnitude is induced in the field winding of an a-c generator when there is any change in the terminal conditions, but this current cannot be sustained by conventional main exciters because their voltage cannot ordinarily be increased fast enough.

The main-exciter Rototrol benefits directly from this induced current through its series-field winding and immediately increases the mmf produced by that winding.

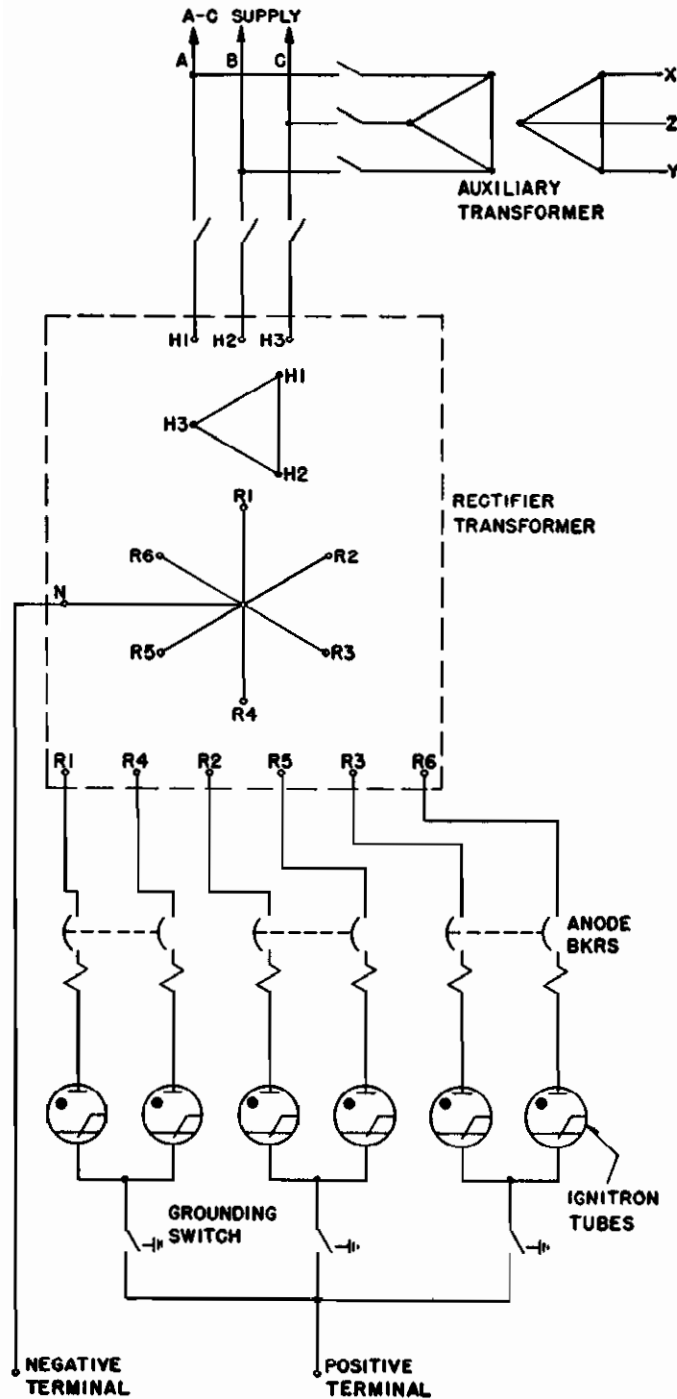

Fig. 19—Simplified circuit of electronic main exciter supplied from the a-c generator terminals through a rectifier transformer.

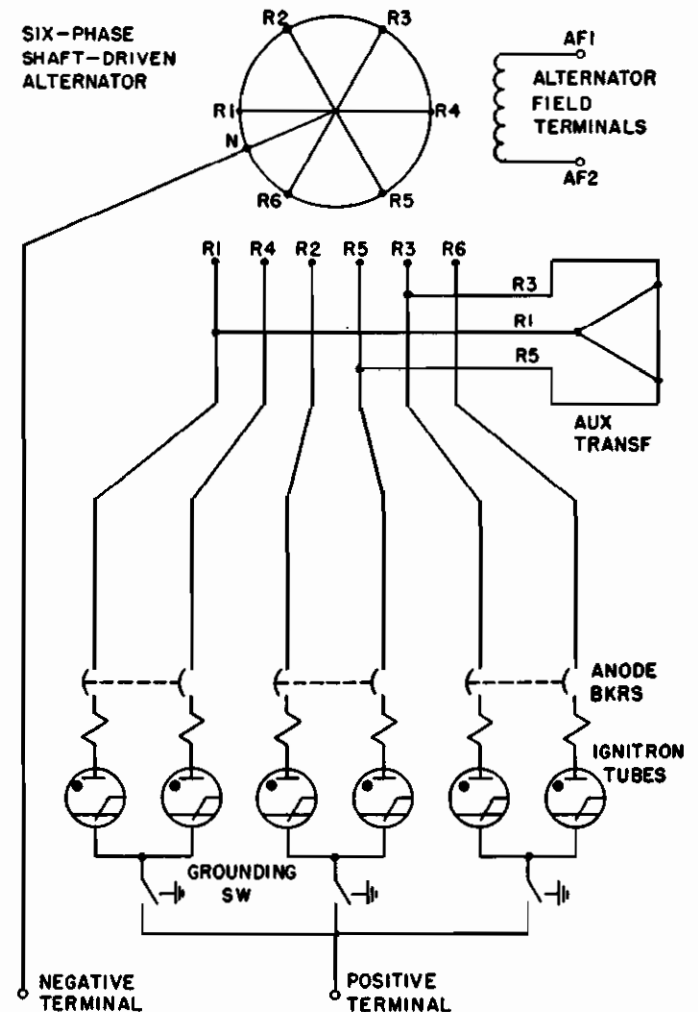
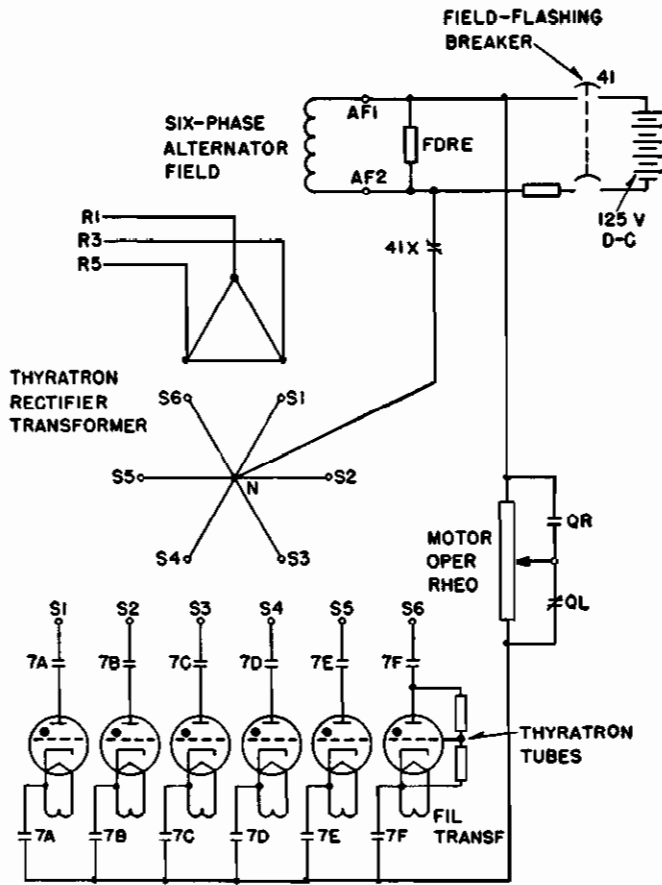
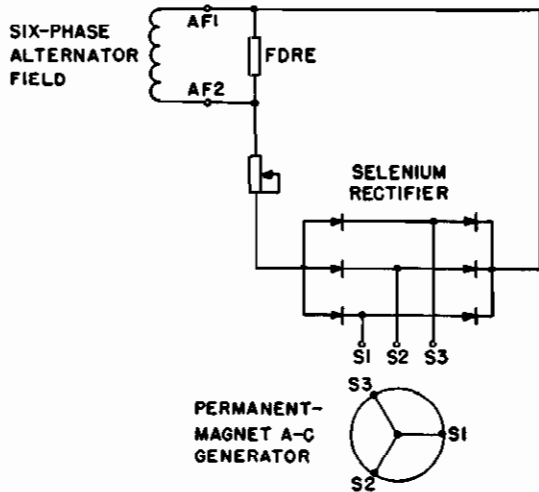

Fig. 20—Simplified circuit of electronic main exciter supplied from a six-phase alternator direct-connected to the main generator shaft.



(a)

FDRE • FIELD DISCHARGE RESISTOR



(b)

Fig. 21—Two methods of supplying excitation for the six-phase alternator.

(a) Self-excitation using a thyatron rectifier supplied from six-phase alternator terminals through a rectifier transformer. A voltage regulator is used to hold the alternator field voltage approximately constant. The battery is used to flash the alternator field to start operation.

The Rototrol terminal voltage is raised to a value that can sustain the induced current. If the induced current is caused by a short circuit, it gradually decays in magnitude, and the Rototrol voltage follows the decay in current. The result is that the Rototrol terminal voltage follows a magnitude dependent largely upon the induced current in the generator field winding, and it cannot be duplicated in a voltage-response test with the exciter unloaded.

The series-field effect in the Rototrol is a desirable phenomenon in improving the response of the excitation system and in aiding to maintain system stability. It enables the main exciter to anticipate the change in a-c generator excitation voltage required. As the series-field mmf is following the induced current, the voltage regulator delivers energy to the control field to increase further the Rototrol terminal voltage. There is some time delay before the control-field current is effective in changing the terminal voltage, whereas the series-field effect is substantially instantaneous.

11. Electronic Main Exciters

Power rectifiers of the ignitron type have been used for many years in industrial applications and have given reliable and efficient performance. Their use as main exciters for a-c synchronous machines has been limited, principally because they cost more than a conventional main exciter. The electronic main exciter, however, offers advantages over rotating types.

An electronic exciter consists essentially of a power rectifier fed from an a-c source of power and provided with the necessary control, protective, and regulating equipment. The coordination of these component parts presents problems that must be solved in meeting the excitation requirements of a large a-c generator.

The output of a rectifier is only as reliable as the source of a-c input power. Thus, this a-c source might be considered a part of the rectifier, and so far as service as an excitation source is concerned, it must be reliable. Three sources have been used in operating installations:

1. A-c power for the rectifier taken directly from the terminals of the a-c generator being excited.
2. A-c power taken from a separate a-c supply that is essentially independent of the a-c generator terminals.
3. A-c power taken from a separate generator which supplies power to the rectifier only, and which has as its prime mover the same turbine that drives the main a-c generator.

In the first of these, the electronic main exciter is self-excited, since its power supply is taken from its own output, and in the second and third forms, it is separately-excited.

When power for the rectifier is supplied by a high-voltage source such as the generator terminals, a rectifier transformer must be used to reduce the voltage to the proper magnitude for the rectifier. The transformer is connected delta on the high-voltage side and six-phase star on the secondary side. No transformer is required when the six-phase shaft-driven generator is used as a power source, since the generator can be designed for the proper voltage.

A simplified circuit diagram of an electronic exciter and

(b) Separate-excitation using a three-phase permanent-magnet generator and dry-type rectifiers.

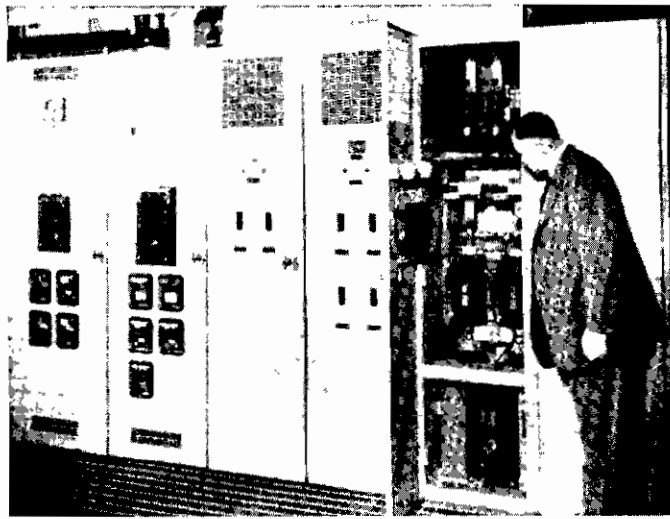
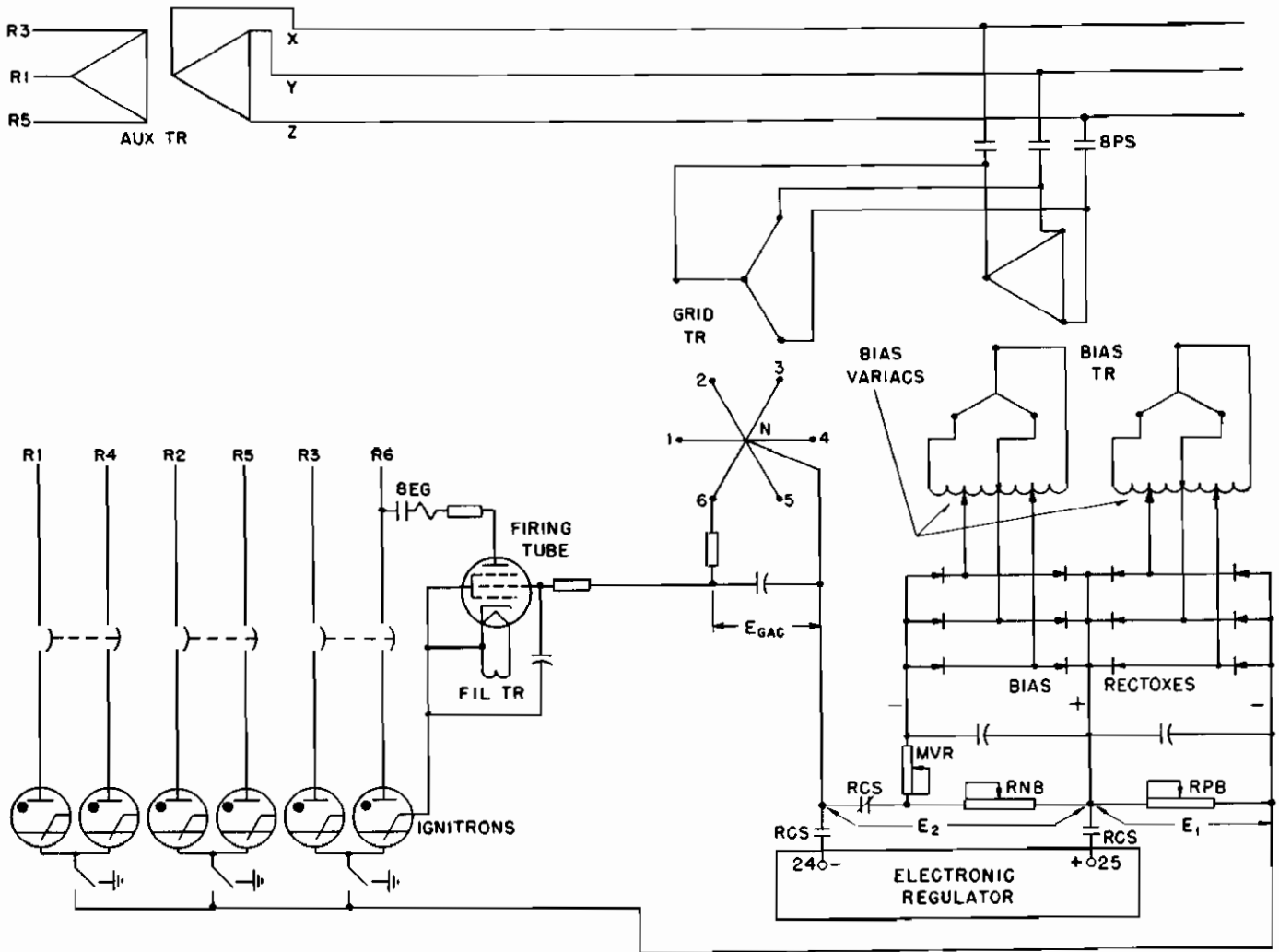

Fig. 22—Installation photograph of electronic main exciter.

rectifier transformer is shown in Fig. 19. The delta primary of the transformer can be energized from the terminals of the main a-c generator, from the plant auxiliary power supply, or from some other independent source. The rectifier comprises three groups of two ignitron tubes each, the two tubes of each group being connected to diametrically opposite phases of the six-phase transformer secondary through a two-pole, high-speed anode circuit breaker. Thus if a breaker is opened, both tubes of a group are deenergized. Each pole of the anode breaker is equipped with a reverse-current trip attachment and the breaker is automatically reclosed. If an ignitron arc-back should occur, the breaker is automatically opened at high-speed and reclosed when the arc-back has been cleared. Should a second arc-back occur within a short time, the anode breaker again opens and locks in the open position to permit inspection of the unit.

The simplified circuit diagram of the electronic exciter supplied from a six-phase alternator is shown in Fig. 20.



RCS—REGULATOR CONTROL SWITCH IN POSITION FOR MANUAL CONTROL

Fig. 23—Method of controlling release of the thyatron firing tube to regulate the main-exciter voltage. The firing control circuit for ignitron tube 6 is shown.

So far as the main-exciter rectifier is concerned, the details of the circuit are the same as Fig. 19. A complication is introduced, however, since it is necessary to provide for excitation of the six-phase alternator. Two methods of accomplishing this are shown in Fig. 21. In the method of Fig. 21(a), the excitation is provided through a six-phase thyatron rectifier, which receives its power input from the same source used to supply the main-exciter rectifier. A permanent-magnet a-c generator is used as the power supply in Fig. 21(b). It consists of high-quality permanent magnets mounted on the same shaft with the main a-c generator to serve as the rotor and a conventional three-phase armature winding on the stator. The output of the permanent-magnet generator is rectified by a three-phase bridge-type selenium rectifier and fed directly into the field of the six-phase alternator. While the shaft-driven generator in Fig. 20 is shown with six phases, it can be a standard three-phase unit in which case a rectifier transformer would be required to convert the ignitron rectifier input to six-phase.

Each group of two ignitron tubes with its anode breaker, cathode-disconnecting switch, firing tubes and associated control circuit is located in one of three individual compartments of the main rectifier cubicle as shown in Fig. 22.

Ignitron Firing Circuit and D-C Voltage Control

The firing circuit for each ignitron tube is of the anode-firing type as shown in Fig. 23. A thyatron tube is connected in parallel with the ignitron through its igniter. The thyatron is made conductive when its anode voltage is positive with respect to its cathode and its grid is released. Current then passes through the ignitron igniter which initiates a cathode spot and fires the ignitron. If the ignitron should fail to conduct for any reason, the thyatron attempts to carry the load current but is removed from the circuit by the thyatron anode breaker.

The magnitude of the output voltage of the electronic exciter is varied by controlling the point on its anode voltage wave at which the ignitron tube is made conductive. This point is determined by releasing the control grid of the firing thyatron, which is controlled by a sine-wave grid transformer, a Rectox supplying a fixed positive bias, a Rectox supplying variable negative bias for manual control, and an electronic regulator supplying variable negative bias for automatic control. The circuits of these devices are shown in Fig. 23.

The grid circuit of the thyatron firing tube can be traced from the cathode of the thyatron through the ignitron to rheostats *RPB* and *RNB* and through the grid transformer to the control grid of the thyatron. The voltage E_1 appearing across rheostat *RPB* is a positive grid bias, while the voltage E_2 appearing across *RNB* is a negative grid bias. The sine-wave voltage E_{GAC} impressed on the grid of the thyatron is delayed almost 90 degrees from the anode voltage and is connected in series with the positive and negative biases. These voltages are shown in Fig. 24.

Rheostats *RPB* and *RNB* are initially adjusted to give the desired values of positive and negative grid-bias voltages. Manual control of the exciter voltage is obtained by changing the setting of rheostat *MVR* which varies the negative bias. The bias voltages E_1 , E_2 and E_{GAC} add to

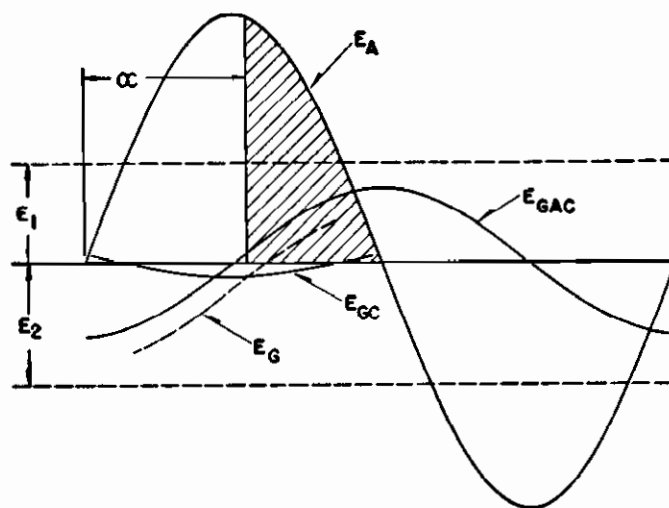

E_A —FIRING TUBE ANODE VOLTAGE
 E_{GC} —CRITICAL GRID VOLTAGE OF FIRING TUBE
 E_{GAC} —PHASE SHIFTED A-C GRID BIAS VOLTAGE
 E_1 —FIXED POSITIVE GRID BIAS
 E_2 —VARIABLE NEGATIVE GRID BIAS
 E_G —TOTAL GRID BIAS VOLTAGE
 α —ANGLE OF GRID DELAY

Fig. 24—Control grid voltages applied to thyatron firing tube.

give a total grid-bias voltage represented by E_G and varying the negative bias determines the point at which the total grid voltage becomes more positive than the critical grid voltage E_{GC} of the firing tube releasing the tube for conduction. The ignitron is then made conductive by current in the igniter and remains conductive for the remainder of the positive half-cycle of anode voltage. The angle α in Fig. 24 is defined as the angle of grid delay.

The use of a positive and negative grid bias in this manner provides for a wide range of control of the angle of grid delay, and consequently, for a wide range of control of the exciter output voltage. When the exciter voltage is under control of the automatic electronic regulator, the manually-controlled negative bias E_2 is replaced by a variable negative bias voltage from the regulator.

12. Electronic Exciter Application Problems

Modern a-c generators have proven their capability of continuous operation over long periods without being shut down for maintenance. It is necessary, therefore, that main exciters and excitation systems be capable of similar operation and that wearing parts be replaceable without requiring shutdown or even unloading. The ignitron and thyatron tubes in the electronic exciter are subject to deterioration and eventual failure and replacement, and it is essential that such a failure and consequent replacement be sustained without interfering with excitation of the a-c generator.

In its usual form, the electronic main exciter is designed so that it can supply full excitation requirements continuously with two of the six ignitron tubes out of service. With all six tubes in service, the capacity is approximately 150 percent of the requirements. Furthermore, the overload capacity of the ignitron tubes is such that the rectifier

can supply full excitation for a short time with only two of the six tubes in service. Should a tube failure occur, the ignitron anode breaker, grounding switch, and firing-tube anode breaker are opened enabling replacement of the ignitron or firing thyatron of any group without disturbing the continuous operation of the remaining two tube groups.

For the electronic exciter to be completely reliable, it must be provided with a reliable source of a-c power. When self-excited from the terminals of the main a-c generator, the input to the rectifier is subject to voltage changes during system disturbances. Thus during nearby faults on the system when it is desirable to increase the generator excitation as much as possible, the rectifier voltage output may be low due to the low a-c voltage. To compensate for the low voltage, the rectifier can be designed for a voltage output much higher than that required during normal operation; that is, the rectifier may be designed to produce normal ceiling voltage when the a-c input voltage is 75 percent of normal. Under normal load conditions the voltage is reduced to that required by control of the firing point. This method of compensation requires a larger rectifier transformer and means that the firing is delayed longer during normal operation.

When separate-excitation is used to supply power to the rectifier, the input is no longer subject to variation during disturbances on the main system. It is possible that a disturbance in the system supplying power to the rectifier may cause a disturbance in the excitation of the a-c generator and a consequent disturbance on the main system. This is overcome by making the rectifier power supply as reliable as possible. Since the same philosophy applies to the system used to supply the powerhouse auxiliaries, this system can be used to supply the rectifier. The shaft-driven three- or six-phase alternator, however, offers the most reliable solution. It is also possible to use duplicate supply with automatic changeover during disturbances in the normal supply, but this is not justified normally.

13. Response of the Electronic Main Exciter

The ignitron rectifier has the ability to increase or decrease its voltage output with substantially no time delay. Compared with the rate of voltage build-up of other types of d-c machines, it might be considered instantaneous. If the response ratio of the electronic exciter were expressed in accord with the definition given in Part I, it would convey a false impression. The line *Oa* in Fig. 25 represents the actual voltage response of the electronic exciter. The line *ab* represents the ceiling voltage. The line *Oc* is drawn so that the area *Ocd* is equal to the area *Oabd* under the actual response curve during the 0.5-second interval. According to the definition, the rate of response is the slope of the line *Oc*, which implies that the exciter voltage has not reached its ceiling value at the end of a 0.5-second interval.

If the distance *Oa* is set equal to 1.0 per unit, then the distance *dc* almost equals 2.0 per unit. The rate of voltage build-up is *dc* divided by 0.5 second or 4.0 per unit per second. The actual time required for the voltage to increase from *O* to *a* is much less than 0.1 second, and there-

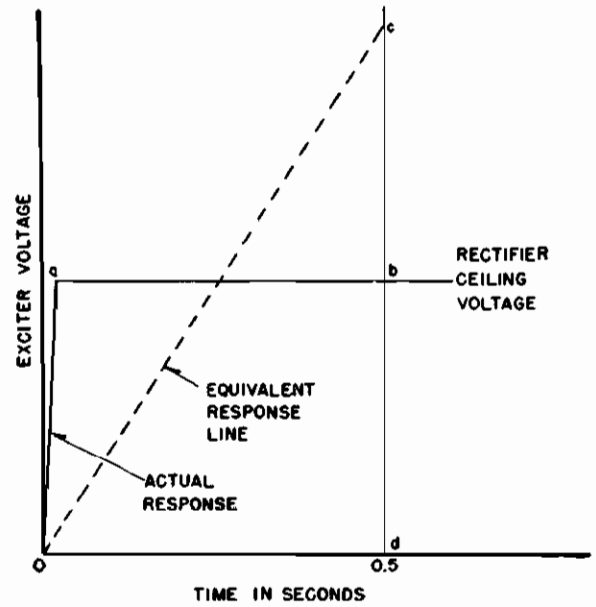

Fig. 25—Response of the electronic main exciter.

fore, the actual rate of voltage increase exceeds 10 per unit per second.

III. PILOT EXCITERS

When the main exciter of an a-c synchronous machine is separately-excited, the d-c machine which supplies the separate excitation is called a pilot exciter. A main exciter can be supplied with excitation from more than one source, as is the three-field main exciter, which has a self-excited field and two separately-excited fields, but the sources of separate excitation are still considered as pilot exciters.

Older excitation systems used a storage battery as a pilot exciter, but maintenance problems soon prompted its replacement with rotating types of d-c machines. Two general classifications of pilot exciters are constant-voltage and variable-voltage types. The constant-voltage type is used where control of the main exciter voltage output is by a rheostat in the exciter's separately-excited field circuit, and the variable-voltage type is used where the pilot-exciter voltage must vary to give variable voltage on the exciter field.

14. Compound-Wound Pilot Exciter

The most common form of constant-voltage pilot exciter is the compound-wound d-c generator. The circuit diagram

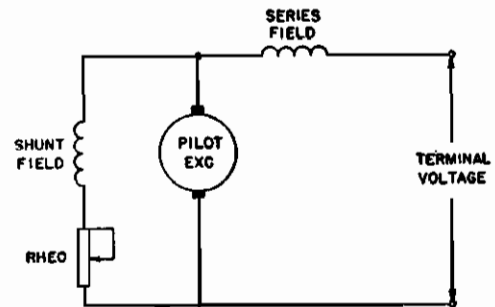

Fig. 26—Compound-wound conventional pilot exciter.

is shown in Fig. 26. The pilot exciter is invariably a 125-volt machine with a self-excited shunt field and a series-excited field, adjusted to give substantially flat-compounding. Thus, regardless of the load on the pilot exciter, the magnitude of its terminal voltage is practically constant.

The compound-wound pilot exciter is normally mounted on the shaft of the main exciter, and where the main exciter is direct-connected, the a-c generator, main exciter, and pilot exciter all rotate at the same speed. A rheostat, either under the control of a voltage regulator or under manual control, is connected in series with the output circuit of the pilot exciter to regulate the voltage applied to the field of the main exciter.

15. Rototrol Pilot Exciter

The Rototrol, described in Sec. 8 as a main exciter, is also used as a variable-voltage pilot exciter. Depending upon the excitation requirements of the main exciter, the Rototrol pilot exciter may be of either one or two stages of amplification. Generally, when the main exciter and Rototrol pilot exciter are direct-connected to the generator shaft and operating at 3600 rpm, the pilot exciter has a single stage of amplification. When the pilot exciter is operated at a speed lower than 3600 rpm, such as 1800 or 1200 rpm, it is of the two-stage type.

The single-stage Rototrol is a stabilized series-excited d-c generator as shown in Fig. 27. The control field is a

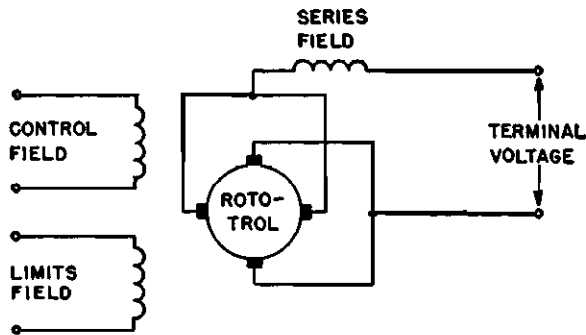

Fig. 27—Equivalent circuit of single-stage Rototrol pilot exciter.

separately-excited shunt field. The principal difference between this and a conventional series-excited d-c generator is the fact that the Rototrol is operated in the unsaturated region, that is, on the air-gap line. Under steady-state conditions, the sustaining series field supplies practically all of the ampere-turns required to maintain the Rototrol terminal voltage. The input to the control field acts as a stabilizing force to hold the voltage at any point on the straight-line portion of the saturation curve.

IV. GENERATOR EXCITATION SYSTEMS

In the ten-year period following 1935, two basic types of generator voltage regulators filled substantially all needs of the electrical industry. These were the indirect-acting exciter-rheostatic regulator and the direct-acting rheostatic regulator. Excitation systems are now in the midst

of a period of changes by reason of progress in the development of regulating and excitation systems. Efforts have been directed particularly toward the development of more reliable, more accurate, more sensitive, and quicker-acting systems. Consequently, there are now many different excitation systems in use, each filling a specific need of the industry.

The preceding sections have discussed the various types of main and pilot exciters in use at present. The remainder of the chapter will be a comprehensive discussion of the application of these d-c machines in excitation systems in conjunction with various types of generator voltage regulators.

Four types of voltage regulators are being used to control the excitation of synchronous machines:

1. Direct-acting rheostatic type
2. Indirect-acting exciter-rheostatic type
3. Impedance-network or static-network type
4. Electronic type.

Each of these are described in their application in various types of excitation systems in the order named.

16. The Direct-Acting Rheostatic Regulator

The Silverstat generator voltage regulator is a common and widely used form of the direct- and quick-acting rheostatic type of regulator. It is specifically designed for the automatic voltage control of small and medium size generators. For generators rated above 100 kva, the Silverstat or SRA regulator is available in five sizes, the largest being used with generators as large as 25 000 kva. A typical SRA regulator of medium size is shown in Fig. 28 (a).

The direct-acting rheostatic type of regulator controls the voltage by the regulator element varying directly the regulating resistance in the main exciter field circuit. The different sizes of SRA regulators are suitable for the automatic voltage control of constant-speed, one-, two- or three-phase a-c generators excited by individual *self-excited* exciters. The exciter must be designed for shunt-field control and self-excited operation, with its minimum operating voltage not less than 30 percent of its rated voltage. Each regulator is designed for and limited to the control of one exciter.

Where a-c generators are operated in parallel and are within the range of application of this regulator, the practice is to provide each generator with an individual exciter, with the exciters operated non-parallel. Each generator and its exciter is provided with an individual regulator and suitable cross-current compensation provided between the regulators.

Sensitivity—The sensitivity of a generator voltage regulator is the band or zone of voltage, expressed as a percentage of the normal value of regulated voltage, within which the regulator holds the voltage with steady or gradually changing load conditions. This does not mean that the regulated voltage does not vary outside of the sensitivity zone, but does mean that when the regulated voltage varies more than the percentage sensitivity from the regulator setting due to sudden changes in load or other system disturbances, the regulator immediately applies corrective action to restore the voltage to the sensitivity zone.

Regulator sensitivity must not be confused with overall

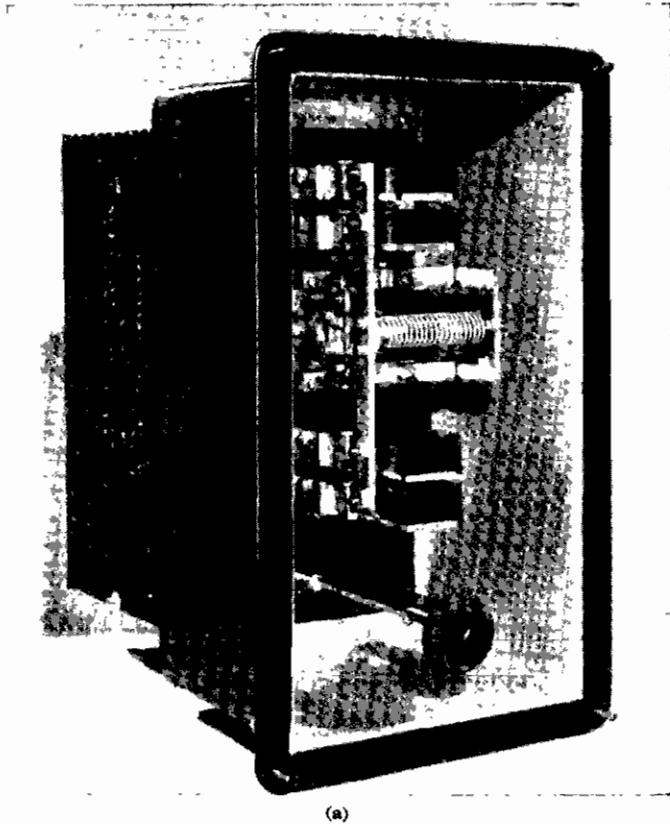

(a)

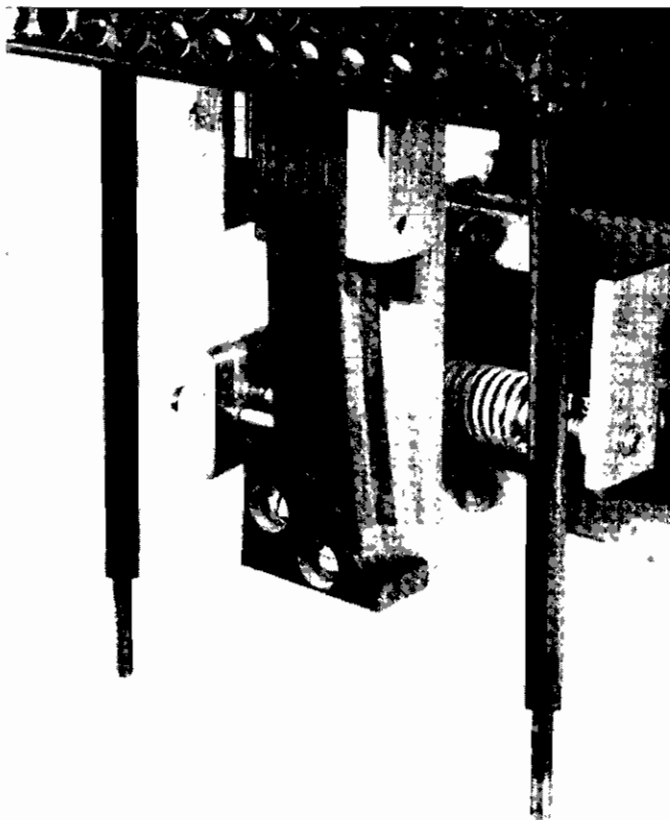

(b)

Fig. 28—(a) SRA-4 Silverstar generator voltage regulator.
(b) Silver-button assembly of Silverstat regulator.

regulation, which involves not only regulator sensitivity but also the time constants of the machines and the character and magnitude of the voltage changes. The magnitude and rate of load change determine how far the voltage deviates outside of the regulator sensitivity zone, and the time constants of the machines chiefly determine the time required to restore the voltage to the sensitivity zone. For these reasons only sensitivity can be specified so far as the voltage regulator is concerned and not overall regulation, which involves factors over which the regulator has no control.

The rated sensitivity of the SRA voltage regulators depends on the size of the regulator. The SRA-1 and SRA-2, the two smaller sizes, have rated sensitivities of plus or minus $2\frac{1}{2}$ and $1\frac{1}{2}$ percent, respectively. The larger SRA-3, SRA-4 and SRA-5 regulators are rated at plus or minus $\frac{1}{2}$ of 1 percent sensitivity.

17. Operation of the Direct-Acting Rheostatic Regulator

The silver-button assembly, Fig. 28 (b), provides the means for changing the resistance in the exciter shunt-field circuit under control of the regulator. This basic assembly consists of a group of spring-mounted silver buttons so arranged that the buttons are separated from each other

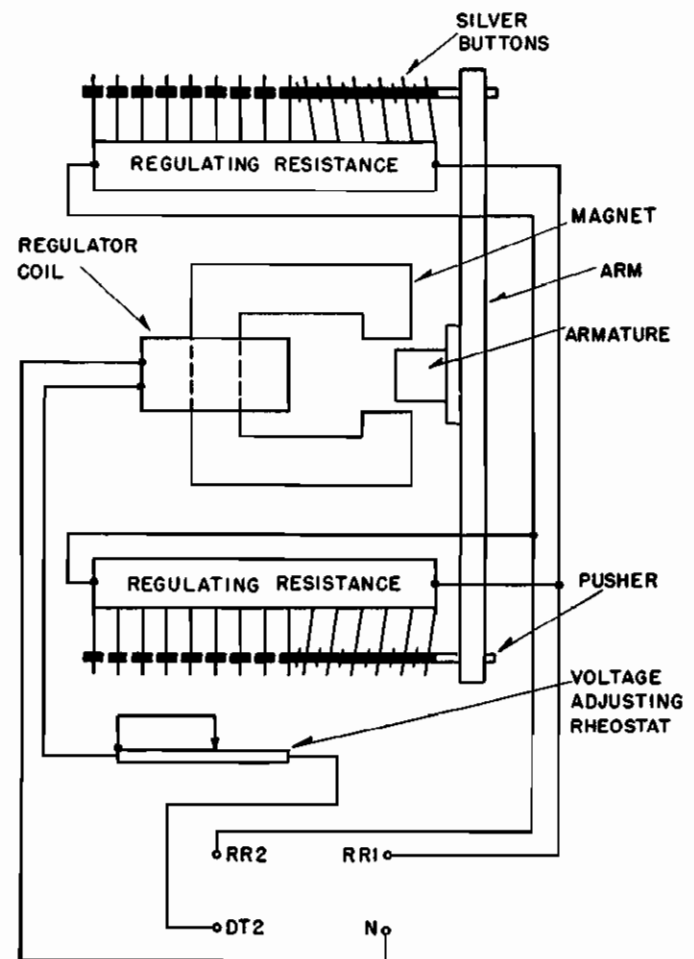

Fig. 29—Schematic internal diagram of SRA-3 Silverstat regulator.

normally, but can be closed or opened in sequence by a suitable driver having a travel of a fraction of an inch. The springs or leaves that carry the silver buttons are insulated from each other and each leaf is connected to a tap on a resistance element as shown in Fig. 29. Varying amounts of the resistance are short circuited by closing of the silver-button contacts. One or more of these basic elements are used in regulators of different sizes, four being used in the SRA-4 regulator illustrated in Fig. 28 (a).

The control element of the regulator is a d-c operated device. A spring-mounted armature is centered in the air gap of the electromagnet as shown in Fig. 29. In regulating a-c voltage, a full-wave rectox rectifier is used to convert the a-c to d-c for energizing the control element.

A typical excitation system under control of an SRA regulator is shown schematically in Fig. 30. The regulating

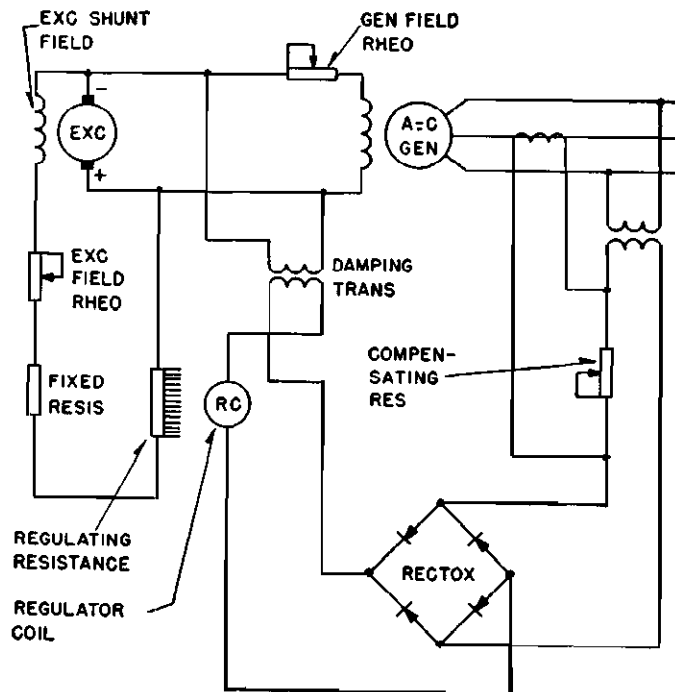

Fig. 30—Self-excited main exciter controlled by Silverstat regulator. The compensating resistance is used to provide cross-current compensation during parallel operation of a-c generators or to provide line-drop compensation.

resistance is connected directly in the exciter shunt-field circuit. At one end of the travel of the moving arm, all of the silver buttons are apart from each other, placing maximum resistance in the field circuit. At the other end of the travel, the buttons are closed and the resistance is short circuited. The moving arm can hold the resistance at any intermediate value and, since the travel is short, all the resistance can be inserted or removed from the field circuit quickly. The speed of operation of the regulating element depends upon the magnitude and rate of change of the operating force. With a sudden drop in a-c voltage of 10 to 12 percent, the time required for the regulator to remove all resistance from the exciter shunt-field circuit is approximately 0.05 second or 3 cycles on a 60-cycle basis.

The regulating action of the SRA regulator is that of a semi-static device that operates only when a correction in

voltage is necessary. For a given value of regulated voltage and load on the machine being regulated there is a corresponding value of regulating resistance required in the field circuit; and a corresponding position of the moving arm and silver buttons that gives this value of resistance. Under such conditions the magnetic pull on the moving arm is balanced against the spring pull at that position of its travel. When there is a change in load on the machine being regulated, a corresponding change in voltage results, and the voltage is restored to its correct value by the moving arm and silver buttons taking a new position. Since the pressure on silver contacts determines the resistance of the contacts, an infinite number of steps of regulating resistance are obtained. If the required value of exciter field resistance should lie between two of the tapped points of the regulating resistance, the pressure of the silver contacts changes to provide the correct intermediate value of resistance.

The fixed resistance in the exciter field circuit in Fig. 30 is used when it is desired to limit the exciter shunt-field current when the maximum or ceiling current is such as to interfere with the best performance of the voltage regulating equipment. The exciter shunt-field rheostat and the generator field rheostat are provided primarily for control of the generator excitation when the regulator is not in service. Excitation current in the generator field can be regulated by changing the exciter output voltage or by holding the exciter voltage constant and changing the generator field resistance. When the voltage regulator is in

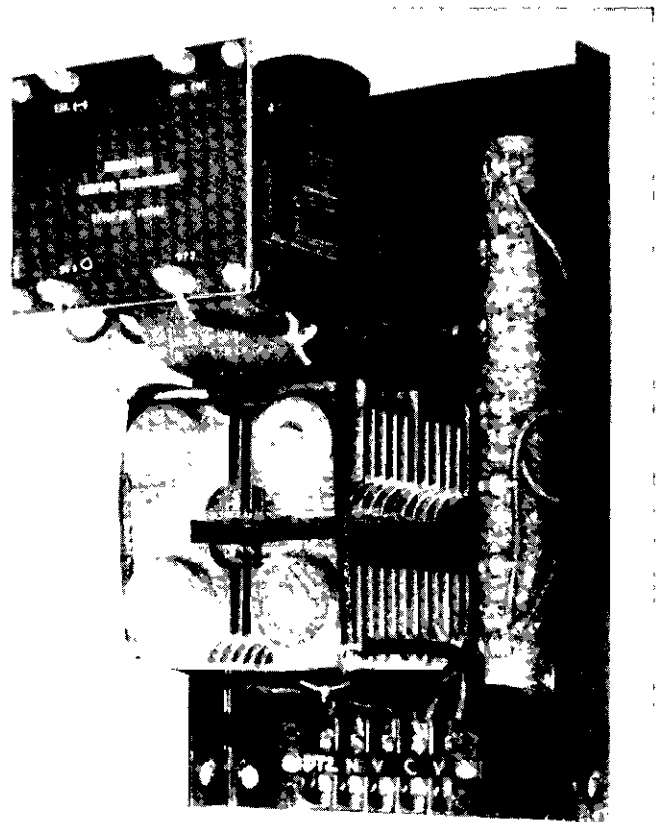

Fig. 31—Silverstat regulator damping transformer and rectox rectifier assembly.

operation and controlling the generator voltage, the exciter shunt-field and generator field rheostats are ordinarily turned to the "all out" position so that the regulator has full control of the excitation voltage.

Damping—To stabilize the regulated voltage and prevent excessive swinging under various conditions of excitation change, a damping effect is introduced into the regulator coil circuit by means of a damping transformer as shown in Fig. 30. The damping transformer is illustrated in Fig. 31. The use of this device eliminates the need for dashpots or similar mechanical anti-hunting devices.

The damping transformer is of a special type having a small air gap in the laminated-iron magnetic circuit. One winding is connected across the field of the generator whose voltage is being regulated, and the other winding is connected in series with the voltage regulator coil. When there is a change in excitation voltage as a result of the regulating action of the regulator, energy is transferred by induction from one winding to the other of the damping transformer. This energy introduced into the circuit of the regulator coil acts by reason of its direction, magnitude, and time relation to electrically damp excessive action of the moving arm, preventing the moving arm from carrying too far the change in regulating resistance and consequent change in generator excitation. Since the damping transformer operates only when the excitation of the generator is changing, it has no effect when the regulated voltage is steady and the regulator is balanced.

Parallel Operation—As is true with most generator voltage regulators, the SRA regulator can control only one exciter at a time. Where several a-c generators operate in parallel and all the generators are excited from one common exciter, a single Silverstat regulator can be used, provided the exciter is of a size that is within the range of application of this type of regulator. However, where a-c generators operate in parallel, the usual practice is to provide each one with an individual exciter controlled by an individual regulator. This scheme of operation requires that the exciters be operated non-parallel, and it is necessary to supply a means of assuring proper division of reactive kva between the generators. The division of the kilowatt load among paralleled a-c generators is dependent upon the power input to each generator and is controlled by the governor of its prime mover. Thus the division of kilowatt load is practically independent of the generator excitation. However, changes in the field excitation of paralleled a-c generators do affect the reactive kva or wattless component of the output, and the division of the reactive kva is directly affected by the operation of the voltage regulators.

Thus, wattless current circulates between the paralleled a-c generators unless some provision is made whereby the generators are caused to properly divide the reactive kva. This is accomplished by means of cross-current compensation, which functions to cause each generator to shirk wattless current by means of a slight droop in the regulated voltage with increase in the wattless component of current. The effect of the small droop required is usually negligible under operating conditions as found in actual practice.

For three-phase a-c generators with the SRA regulator, the compensation is obtained by a standard current transformer connected in one lead of each generator being regu-

lated as shown in Fig. 30. The current transformer is connected to an adjustable resistance in the a-c supply circuit to the regulator operating element. The adjustable resistance permits adjustment of the compensation to suit the application. The current transformer is connected in one generator lead, while the potential transformer that operates the regulator is connected to the other two leads. Thus the phase relationship is such that for lagging reactive kva, the voltage drop across the compensating resistance adds to the a-c voltage energizing the regulator and subtracts in the case of leading reactive kva. This action tends to cause the regulator to lower excitation for lagging reactive kva and raise excitation for leading reactive kva. In this manner each generator tends to shirk reactive kva, and the wattless power is automatically divided in proportion among the paralleled a-c generators.

In many applications, reactance in the form of power transformers, bus reactors, etc., exists between paralleled a-c generators. If each generator is excited by an individual exciter under control of an individual voltage regulator, and if the reactance is such as to cause from four to six percent reactive drop between the two generators, then stable operation and proper division of the wattless component can usually be obtained without using cross-current compensation between the regulators. This is because the reactance produces an effect similar to that obtained where cross-current compensation is used.

18. Indirect-Acting Exciter-Rheostatic Regulator

In recent years the increase in capacity of generating units, the extension of transmission systems, and the interconnection of established systems, have reached a point where quick-response excitation is valuable for improving stability under fault conditions and large load changes. On applications of this kind the type BJ regulator is particularly adapted to the control of a-c machines employing quick-response excitation. The BJ regulator is of the indirect-acting exciter-rheostatic type for the automatic control of medium and large size a-c generators.

The indirect-acting exciter-rheostatic type of generator voltage regulator controls the voltage of an a-c machine by varying the resistance in the field circuit of the exciter that excites the a-c machine. The exciter is preferably separately-excited from a pilot exciter or other source. If the exciter is self-excited, its minimum operating voltage must not be less than 30 percent of its rated voltage if stable operation is to be obtained. When lower voltages are necessary, the main exciter must be separately-excited.

A schematic wiring diagram of the BJ generator voltage regulator and its auxiliary contactors is shown in Fig. 32. This diagram in conjunction with the simplified schematic of Fig. 33 is used to describe the operation of the device.

The main control element of the regulator is energized from two single-phase potential transformers connected to the a-c machine leads. Two sets of contacts are on the moving lever arm of the regulator element shown in Fig. 32, namely, the normal-response contacts *R-L* and the quick-response contacts *AR-AL*. The normal-response contacts control the rheostat motor contactors *NR* and *NL*, to raise or lower the a-c machine voltage, respectively. The quick-response *AR* and *AL* contacts control the high-

speed contactors *QR* and *QL*, which are the "field forcing up" and "field forcing down" contactors, respectively. When contactor *QR* in Fig. 33 is closed, all external resistance is shorted out of the main-exciter field circuit, and when *QL* is opened by energizing its coil, a block of resistance is inserted in the field circuit.

Normal Response—When the a-c voltage is normal, the regulator lever arm is balanced and in this position

neither the normal-response contacts *R-L* nor the quick-response contacts *AR-AL* are closed. Should the a-c voltage fall below normal by a small amount, depending upon the sensitivity setting of the regulator, the normal-response contact *R* will close, energizing the rheostat motor control contactor *NR*. The contacts *NR* energize the rheostat motor which then turns the rheostat in a direction to remove resistance from the exciter field circuit, thereby increasing the voltage applied to the exciter field.

The rheostat-motor control contactor *NR* has three contacts that close in independent circuits simultaneously. The one circuit is that just described which operates the rheostat motor. The second is the circuit of the anti-hunting winding *NH* of the regulator main control element and the third set of contacts complete a timing-condenser circuit. The anti-hunt device operates to increase the gap distance between the contact faces of the regulator contacts *R* and *L*, thereby opening the circuit at the *R* contacts. This change in position of the *R* contact is equivalent to changing the regulator setting to a lower voltage so far as the raise contacts are concerned, and to a higher voltage so far as the lower contacts are concerned. Where the deviation from normal voltage is small and within the recalibration effect of the anti-hunt device, the immediate

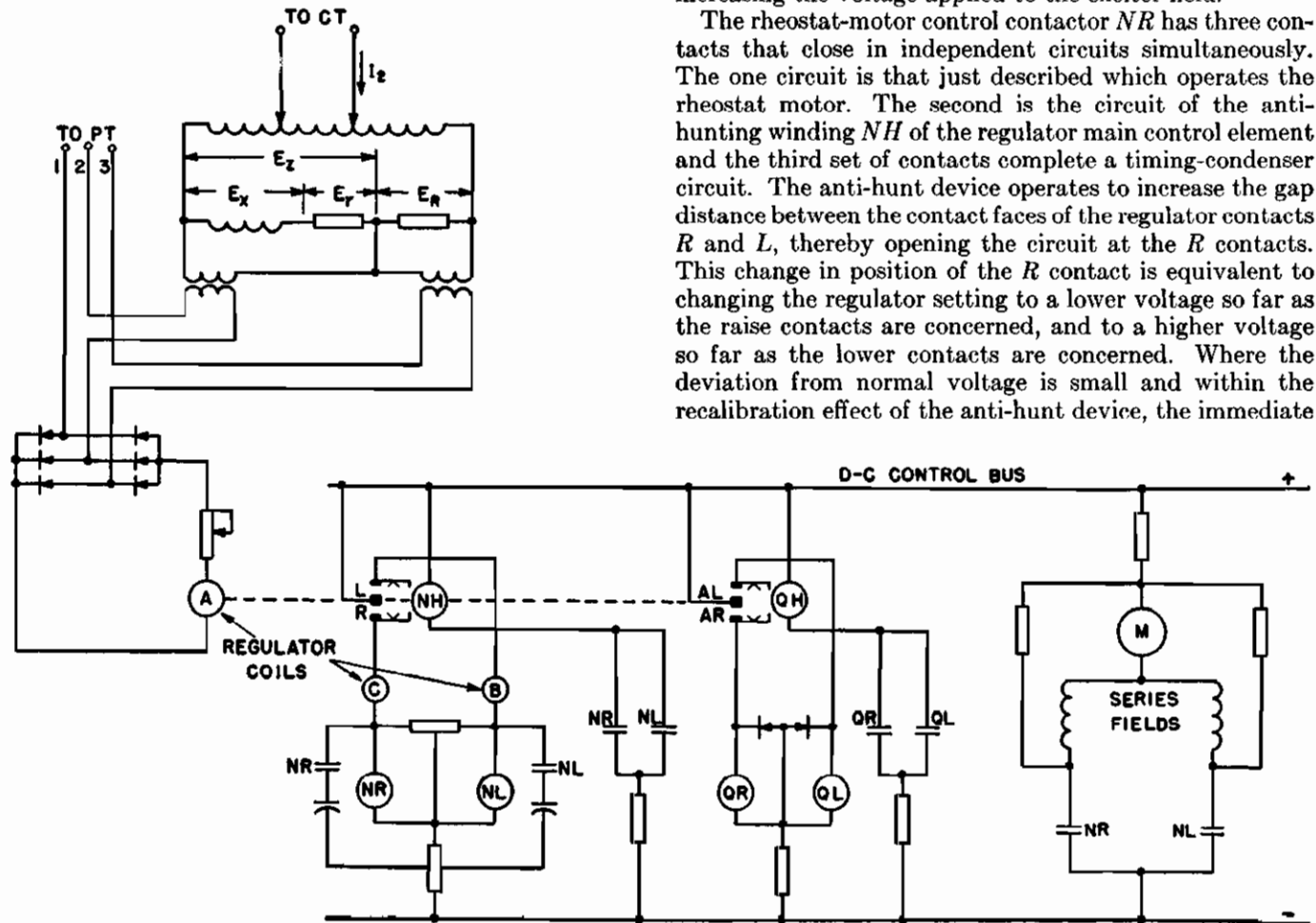

Fig. 32—Schematic diagram of the BJ regulator controlling the voltage of a separately-excited main exciter.

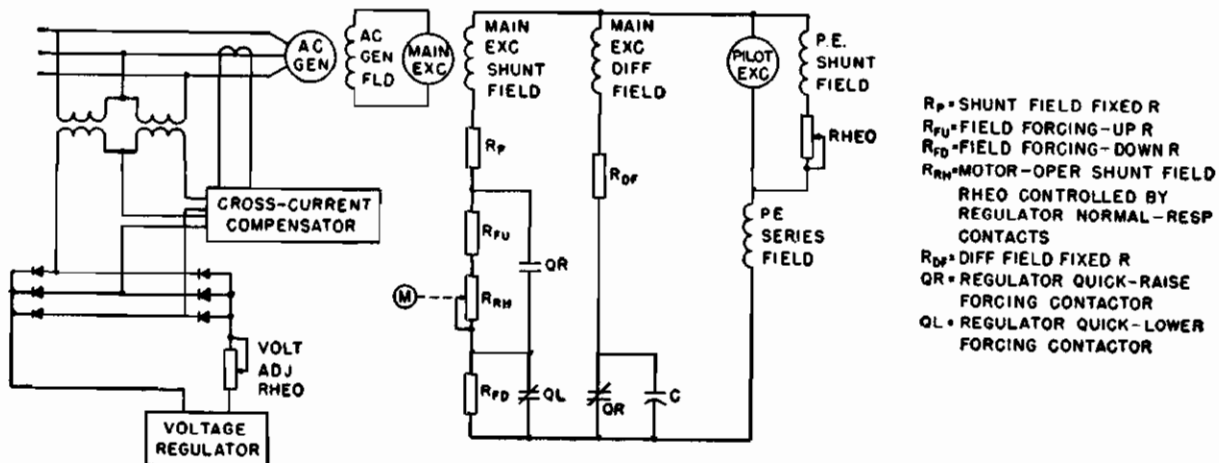

Fig. 33—Main-exciter circuits under control of BJ regulator in Fig. 32.

result of the closing of the contacts on contactor *NR* is to cause the opening of the regulator *R* contact, which in turn opens the circuit to the coil of contactor *NR*, to stop the motor of the exciter field rheostat and thus stop the rheostat moving arm. However, contactor *NR* does not immediately open due to a time-delay circuit around its coil that maintains the coil voltage. Thus the rheostat arm is permitted to move a definite distance, for example, from one button to the next on the rheostat faceplate, and at the end of its time delay, contactor *NR* opens to stop the rheostat motor and deenergize the anti-hunt device.

After the rheostat motor stops, it is desirable to provide some time delay to allow the a-c machine voltage to reach its final value. Such delay is obtained by a dashpot on the anti-hunt device that prevents the regulator contacts from immediately returning to their normal position. After this time delay has expired and the contacts have returned to their normal position, the normal response contact *R* again closes if the a-c voltage has not returned to normal. This starts another cycle of operation such as just described and these cycles continue until the normal value of regulated voltage is established.

Where the original voltage deviation is large enough the regulator contacts remain closed continuously even though the anti-hunt device changes the contact setting. In this case the regulator arm is caused to follow the change in contact position made by the anti-hunt device, and the *R* contact and the contactor *NR* remain closed. This causes the rheostat motor to run continuously until the a-c voltage is within the zone for which the anti-hunt device is set, at which time the notching action takes place to bring the voltage to normal.

By means of the continuous or notching action of the rheostat, dependent upon the magnitude of the voltage change, time is allowed for the a-c voltage to come to rest between each voltage correction as the voltage approaches its normal value. The action of the dashpot is also such that the time required for the contacts to remake is longer as the lever arm approaches the normal voltage position. This results in a decreased motor speed as the rheostat arm moves nearer to its new position, preventing overshooting of the rheostat position and bringing the a-c voltage to normal in a minimum length of time.

When the a-c voltage rises above the regulated value, an action similar to that described for low voltage takes place, except that the regulator contact *L* closes energizing the rheostat motor control contactor *NL*, which operates the rheostat motor in a direction to increase the resistance in the exciter field circuit.

Quick Response—When a large drop in voltage occurs, such as might be caused by a large block of load being thrown on the system or by a fault, the normal-response contacts *R* on the regulator close, followed by closing of the quick-response contacts *AR*. Contacts *AR* close the circuit to the high-speed field-forcing-up contactor *QR*, which short circuits all of the external resistance in the exciter field circuit, applying full exciter voltage to the field circuit. This causes the a-c machine voltage to start to return to normal very rapidly by forcing action.

When the field-forcing-up contactor *QR* closes, an auxiliary contact on this contactor closes at the same time in

the circuit of the anti-hunt device *QH*, which operates to spread the *AR* and *AL* contacts in the same manner as described for the *NH* device and the *R* and *L* contacts. Therefore, if the deviation from normal voltage is within the recalibration effect of the *QH* anti-hunt device, the field-forcing-up contactor closes and opens rapidly while the rheostat arm approaches the required new position. If the deviation from normal voltage is greater than the recalibrated setting of *QH* anti-hunt device, the field-forcing-up contactor closes and remains closed until the a-c voltage is brought within the recalibrated setting.

As the a-c voltage comes within the setting of the *AR* contacts and they no longer close, the normal response contacts *R* take control and by notching the rheostat, return the a-c voltage to normal. Since the rheostat moves at maximum speed while the quick-response contacts are closed, it takes only a minimum of additional movement after the normal-response contacts take control to return the voltage to normal.

When the main exciter has a differential field as shown in Fig. 33, a contact in the *QR* contactor opens the differential-field circuit. In this way, the damping effect of the differential field in slowing the exciter response is removed.

19. Sensitivity of the BJ Regulator

The rated sensitivity of the BJ generator voltage regulator is plus or minus $\frac{1}{2}$ of one percent. The sensitivity is adjusted by varying the spacing between the regulator contacts *R* and *L*. The quick-response contacts are set to a wider spacing than the normal-response contacts so that larger deviations from normal voltage are required to close them. The usual range of settings of the quick-response contacts is from plus or minus $2\frac{1}{2}$ percent to plus or minus 10 percent, the setting depending somewhat on the setting of the normal-response contacts and upon the operating conditions of the particular installation.

The main coil of the control element in Fig. 32 consists of a voltage winding energized by a d-c voltage, rectified from the three-phase a-c source being regulated. Thus, the coil is energized by a voltage equal to the average of the phase voltages and the regulator holds this average voltage within the rated sensitivity zone. The level of the regulated voltage is set by adjustment of the voltage-adjusting rheostat; resistance being added in series with the regulator voltage coil to increase the level of the regulated voltage, and resistance being removed to decrease the level of the regulated voltage. The normal range of adjustment is approximately plus or minus 10 percent from the normal generator voltage.

20. Cross-Current Compensation with BJ Regulator

When cross-current compensation is required to give the voltage regulator a drooping characteristic, one compensator and one current transformer are required, connected as shown in Fig. 32. The compensator is designed to supply a compensating voltage in two phases of the three-phase regulator potential circuit. This insures applying a balanced three-phase voltage to the regulator element, which would not be the case if only one leg was compensated.

The vector diagram of the compensating circuit is shown

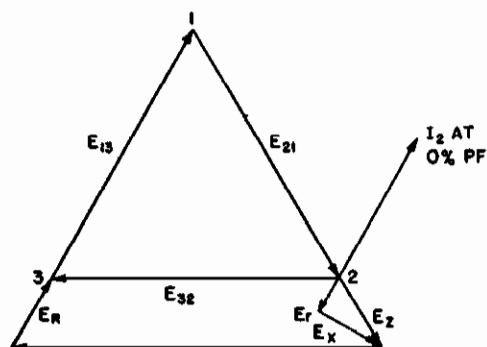

Fig. 34—Vector diagram of cross-current compensation used with BJ regulator. Circuit shown in Fig. 32.

in Fig. 34, the potential transformer secondary voltages being represented by E_{21} , E_{32} and E_{13} . The current applied to the autotransformer of the compensator in Fig. 32 is taken from the secondary of a current transformer in phase 2 of the a-c circuit. Two compensating voltages are produced; one between terminals X1-X2 designated as E_Z on the vector diagram and the other between terminals Y1-Y2 designated as E_R on the vector diagram. Voltages E_R and E_Z are 120 degrees apart in time phase and, therefore, can be added to a three-phase set of voltages without unbalancing it.

The vector diagram shows E_Z and E_R for zero power factor, under which condition maximum compensation is obtained. As the power factor approaches unity, these voltage vectors swing through an arc of 90 degrees and give zero compensation at 100 percent power factor. At zero power factor, vectors E_Z and E_R add directly to vectors E_{21} and E_{13} , respectively. For power factors greater than zero, only a proportionate component of these voltages E_Z and E_R add directly to voltages E_{21} and E_{13} . The addition of these compensating voltages to the line voltages as the load increases or the power factor changes gives the regulator element a high voltage indication resulting in a reduction or droop in regulated voltage. Usually the compensator should cause from four to six percent droop in voltage at zero power factor full load on the a-c generator.

21. Line-Drop Compensation with BJ Regulator

The wide use of interconnected power systems has eliminated to a large extent the need for line-drop compensation. However, it is sometimes desirable to regulate for a constant voltage to be maintained at some point on the system external to or distant from the station where the a-c machine and its regulator are located. The principle by which this is accomplished is shown by the circuit and vector diagrams of Fig. 35.

The voltage regulator is to maintain the voltage E_2 constant. If it were possible to supply the regulator with pilot wires so that it could measure the voltage at the load center, the regulator could adjust the excitation of the generator to maintain E_2 constant. Since in actual practice it is impractical to use pilot wires, the regulator potential winding is energized from the generator bus voltage E_1 , and the two components XI and RI are subtracted from it artificially by the compensation. The resultant voltage E_2 is then supplied to the regulator. If the components XI

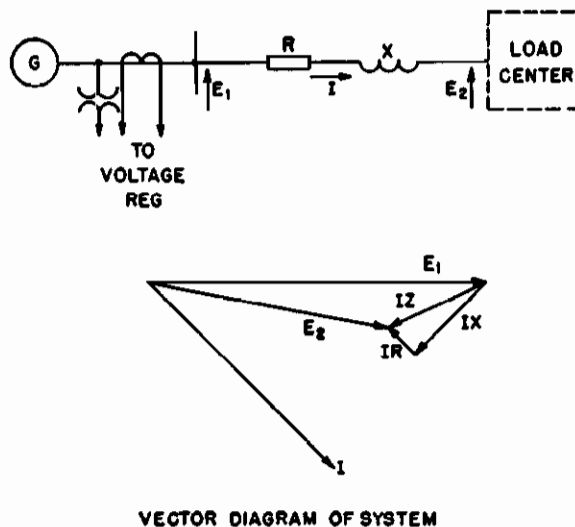

Fig. 35—Principle of line-drop compensation.

and RI are proportioned to and in phase with the corresponding values of line reactance and resistance voltage drops, the regulator controls the voltage as if it were connected by pilot wires to the load center.

In general, since the reactance component XI of the line predominates, it is necessary to compensate mainly for this component of the line drop, the resistance component RI having a relatively small effect.

Parallel operation of a-c generators, each under the control of a voltage regulator, requires a droop in regulated voltage with an increase in wattless load. On the other hand, reactance line-drop compensation requires a rising characteristic for the regulated voltage with an increasing wattless load. In order to compensate for reactive cross current between machines and for complete line drop when machines are operating in parallel in the same station, three current transformers and two compensators with suitable auxiliary equipment must be used for each machine. In any event, the XI line-drop compensation must never exceed the XI cross-current compensation; i.e., there must be a net droop in regulated voltage with increase in wattless load.

Complete line-drop compensation is not always necessary, and a simple compromise solution is available to provide approximate line-drop compensation and reactive-droop compensation. The RI -drop compensation is set to approach the XI drop of the line for some average power factor. When the RI -drop compensation is so set, the XI -drop compensation can be adjusted independently to provide the required cross-current compensation, and there is no interference between the two compensators.

22. Synchronous Condenser Excitation with BJ Regulator

The type BJ generator voltage regulator can also be used to control the excitation of a synchronous condenser. The circuit is essentially the same as that shown in Figs. 32 and 33.

When the excitation of a synchronous condenser is increased above a certain value, the condenser furnishes a lagging (overexcited) current to the system thereby caus-

ing the voltage to rise. In a similar manner, decreasing the excitation lowers the voltage. Thus, when a generator voltage regulator is applied to a synchronous condenser, it regulates the line voltage to a constant value by varying the excitation of the condenser, provided the condenser has sufficient corrective rkva capacity.

It is often necessary that the condenser furnish leading (underexcited) rkva as well as lagging (overexcited) rkva, and it is necessary to reduce the excitation to an extremely low value. Where the minimum value is less than 30 percent of the main exciter rated voltage, it is necessary to use a separately-excited main exciter. In many cases it is necessary to reverse the excitation voltage to obtain full leading rkva capacity from the condenser. This is accomplished by the differential field in the conventional main exciter, and by reversing the pilot exciter voltage in the case of the Rototrol pilot exciter.

In the operation of a synchronous condenser under abnormal conditions, a situation may occur where the condenser does not have sufficient corrective rkva capacity to handle all, or the most severe, system requirements. At such a time, the regulator in trying to hold the line voltage overexcites the condenser, causing it to carry excessive current and become overheated. To protect against this condition, a current-limiting device is used to limit the maximum excitation voltage to a level that does not cause damage due to continuous overloading of the condenser.

When the BJ regulator is used to control the excitation of a synchronous condenser, a time-delay current-limiting device is used. The equipment is designed to recognize two conditions; first, the case of a slowly rising load current to a predetermined limiting or unsafe value, and second, a sudden increase in load current such as might be caused by a system fault.

Protection against overcurrent is provided by a current-operated device having its operating coil energized by the line current and having its main contacts connected in series with the main control contacts of the voltage regu-

lator. If the synchronous condenser load is gradually increased, the current-limiting contact in series with the *R* contact of the regulator opens the "raise" control circuit and prevents any further increase in excitation. At the same time, a second contact of the current-limiting device energizes the "lower" control circuit of the regulator, causing the excitation and load current to be reduced to the safe limiting value. This protection against a gradual increase in load operates in the normal-response *R-L* circuits of the voltage regulator.

In the case of a sudden increase in load current, an instantaneous overcurrent relay set to pick-up at a higher value of current than the current-limiting device closes its contacts. One set of contacts initiates a timing cycle, and the other set deenergizes an auxiliary relay. Deenergizing the auxiliary relay allows the contacts of the voltage-regulating element to remain in control for the time setting of the timing relay, thus permitting the use of both normal- and quick-response excitation for stability purposes under fault conditions.

Control of the excitation is automatically returned to the voltage-regulator control element when the overload disappears. Should the decreasing overload remain for a time below the setting of the instantaneous overcurrent relay but within the setting of the current-limiting element, the latter maintains control to prevent increase in excitation.

23. Impedance-Type Voltage Regulator

The excitation system shown in Fig. 36 employs a main-exciter Rototrol to supply excitation to the a-c generator. With the high degree of amplification obtainable with a Rototrol, the energy requirements of the control field are sufficiently small that they can be supplied by instrument transformers. The intelligence transmitted to the control field of the Rototrol as a function of the generator terminal voltage is determined by the voltage-regulator potential unit, voltage adjusting unit, and automatic control unit. These voltage-regulator devices consist entirely of imped-

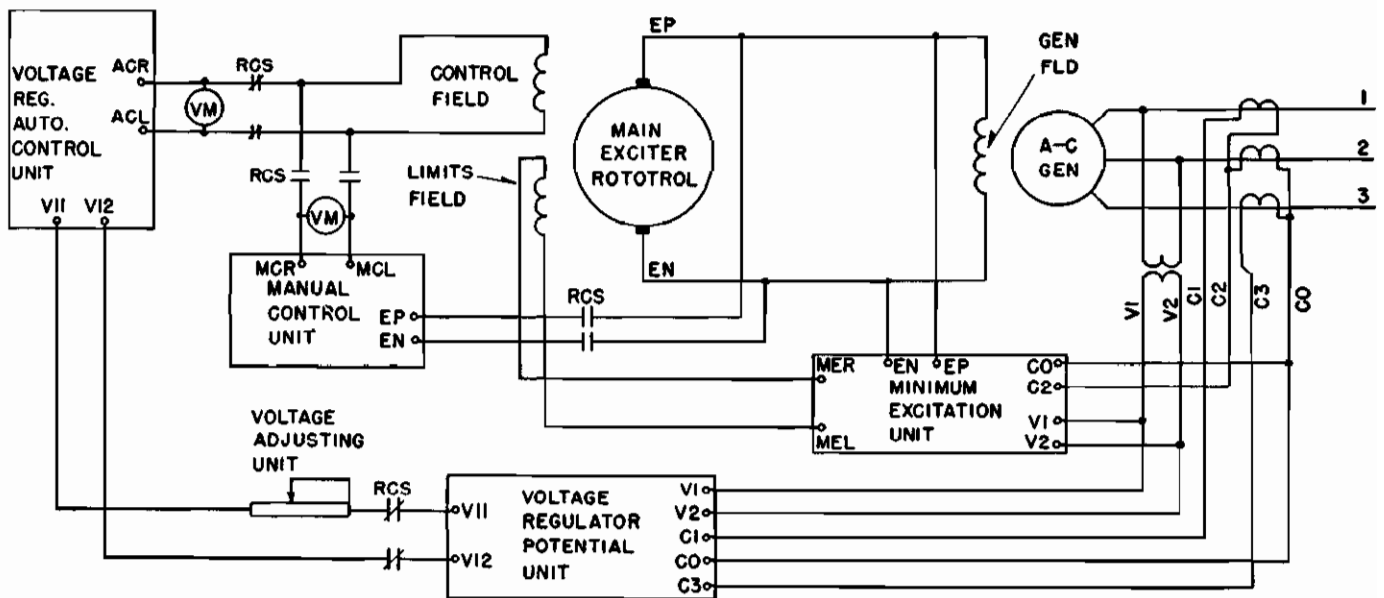

Fig. 36—Block diagram of the impedance-type voltage regulator as used in a main-exciter Rototrol excitation system.

ance elements and from this consideration the combination of devices in Fig. 36 is referred to as an impedance-type or static-type voltage regulator.

The voltage regulator potential unit is energized by the generator line-to-line voltage and the currents of two phases. Its output is a single-phase a-c voltage, applied to the series connection of the voltage adjusting unit and the automatic control unit. The automatic control unit is a voltage-sensitive device, the output of which is a d-c voltage. The polarity and magnitude of this d-c voltage are determined solely by the magnitude of the impressed a-c voltage. The output of the automatic control unit is the control signal that energizes the control field of the main-exciter Rototrol.

When the generator output voltage is exactly at the regulated value, the output voltage of the automatic control unit is zero. If the generator voltage increases above the regulated value, the d-c output voltage is in the direction to decrease the excitation voltage, working through the Rototrol exciter. When the generator voltage falls below the selected value, the d-c output voltage of the automatic control unit is in the direction to increase the a-c generator excitation.

When the voltage regulator is not in service, manual control of the a-c generator excitation is by means of the manual control unit. To guarantee synchronous machine steady-state stability, that is, insure adequate excitation for all kilowatt loads, a minimum excitation unit is used. The minimum excitation unit used with the Rototrol excitation systems is of a form that provides a variable minimum limit depending on the kilowatt load.

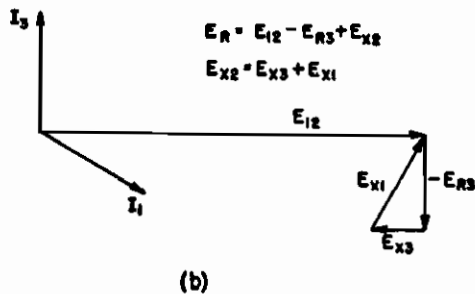
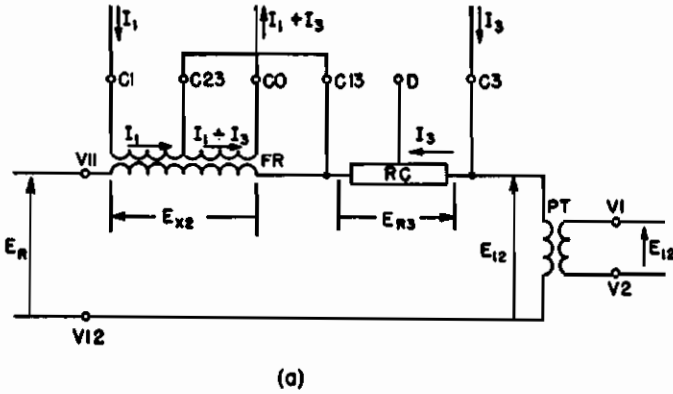

Fig. 37—Impedance-type regulator potential unit.

- (a) Schematic diagram.
- (b) Vector diagram.

Potential Unit—The voltage-regulator potential unit, shown schematically in Fig. 37, consists of a potential transformer, a filter reactor and a set of resistors. The output voltage of the potential unit is directly proportional to the positive-sequence component of the generator terminal voltage, and therefore, the voltage regulator is not affected by generator voltage unbalance and regulates to constant positive-sequence voltage. The circuit is a negative-sequence voltage-segregating filter so connected that the negative-sequence voltage is subtracted from the line voltage which, in the absence of a zero-sequence component, yields positive-sequence voltage.

The primary of the filter or mutual reactor is energized by the phase 1 and 3 current transformers. The flux produced thereby induces a voltage in the secondary winding which is added vectorially to the phase-3 drop in the

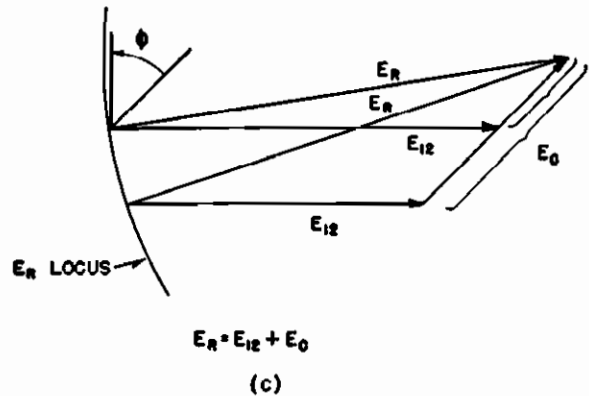
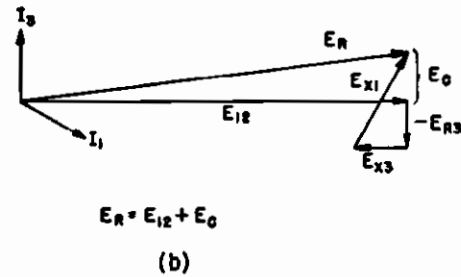
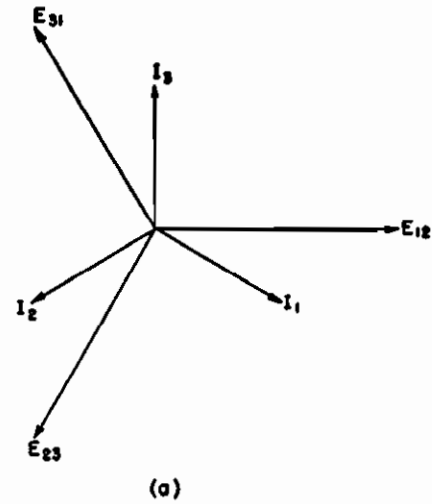

Fig. 38—Vector diagrams showing how cross-current compensation is obtained with the potential unit of the impedance-type regulator.

resistor RC , the sum being proportional to the negative-sequence voltage at the generator terminals. This negative-sequence voltage is the component of the three-phase voltage that represents the unbalance in voltage resulting from load unbalance. It is subtracted vectorially from the generator voltage to give the desired positive-sequence voltage across the terminals $V11$ and $V12$.

The potential unit can also provide compensation for parallel operation of a-c generators when each machine is equipped with a voltage regulator. Reactive-droop compensation is obtained by adjustment of the resistance RC in the potential unit in Fig. 37. The vector relations of the generator line currents and terminal voltages are shown in Fig. 38 (a). If the ohmic value of the resistor RC is 100 percent, the voltage equation of the circuit and the vector diagram are those shown in Fig. 37. If the ohmic value of RC is reduced to 50 percent, the vector diagram becomes that shown in Fig. 38 (b). E_R and E_{12} no longer are identical, although for unity power factor their difference in magnitude is of negligible proportion. The difference vector E_C can appropriately be called the reactive-droop compensator voltage. Assuming a given lagging power factor generator load, the vector diagram of Fig. 38 (c) shows how the generator terminal voltage E_{12} must vary for the automatic control-unit input voltage E_R to remain constant. As the generator load increases, E_C also increases and E_{12} must decrease, since E_R remains constant in magnitude. Thus the generator voltage is given a drooping characteristic with increase in lagging power factor load.

Voltage Adjusting Unit—The voltage adjusting unit in Fig. 36 is a rheostat that enables the operator to set the a-c generator regulated voltage at any value within a band of plus or minus 10 percent of the rated generator voltage. By means of the voltage adjusting unit, the resistance between the generator terminals and terminals $V11$ and $V12$ of the automatic control unit can be changed, causing a directly proportional change in voltage drop in the circuit. The drop requires a change in a-c generator voltage to produce the regulator balance-point voltage across the terminals $V11$ and $V12$.

Automatic Control Unit—The automatic control unit is the voltage-sensitive element of the impedance-type voltage regulator. It measures the voltage to be regulated and delivers energy to the main-exciter control field only when necessary. The voltage-sensitive circuit in Fig. 39 consists essentially of two parallel-circuit branches; one containing a capacitor and the other a saturating reactor. The voltage-current characteristic curves of the capacitor and saturating reactor are shown in Fig. 39 (b). The curve of the reactor indicates that its current increases more rapidly than voltage, and the currents through the two branches of the circuit are equal at only one value of voltage where the characteristics intersect. This point of intersection is called the balance point of the two impedances. The operation of the voltage regulator depends upon the fact that when the voltage increases above this point, the current in the reactor is greater than the current in the capacitor. When the voltage decreases below the balance point, the capacitor current is the greater.

The output of the reactor circuit and the output of the capacitor circuit are rectified by single-phase full-wave

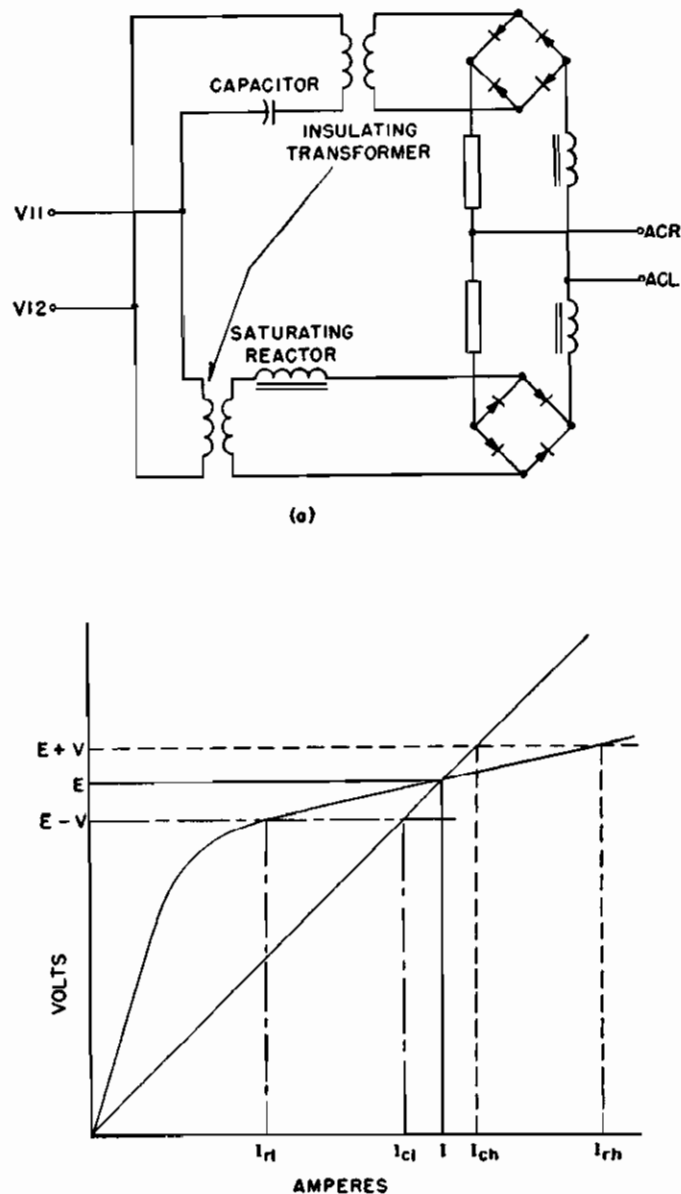

Fig. 39—Impedance-type regulator automatic control unit.

- (a) Circuit diagram.
 (b) Intersecting impedance characteristics of saturating reactor and capacitor.

dry-type rectifiers, which are connected with additive relation in series through a resistor and smoothing reactors. The control field of the Rototrol is connected between a mid-tap on the resistor and the opposite side of the rectifier circuit. When the applied voltage is at the balance point and the capacitor and reactor currents are equal in magnitude, the output currents of the rectifiers are equal and circulate between the rectifiers. Under this condition there is no potential difference between the terminals ACR-ACL of the Rototrol control field and no current flows in the field. Should the a-c voltage become low, however, the rectified current of the capacitor circuit is large compared with that of the reactor circuit raising the potential of terminal ACR above that of ACL and causing current to flow in the control field in a direction to increase the excitation voltage and

raise the a-c voltage. For an increase in a-c voltage, the direction of current flow in the control field would be reversed causing a reduction in excitation voltage. Thus with normal a-c voltage applied to the automatic control unit, the control-field current is nearly zero and any deviation in a-c voltage causes a corrective current to flow in the control field.

The current in the control field of the Rototrol is directly proportional to the horizontal difference between the capacitor and saturating reactor volt-ampere characteristics in Fig. 39 (b). Examination of the curves shows that the control-field current is approximately proportional to the

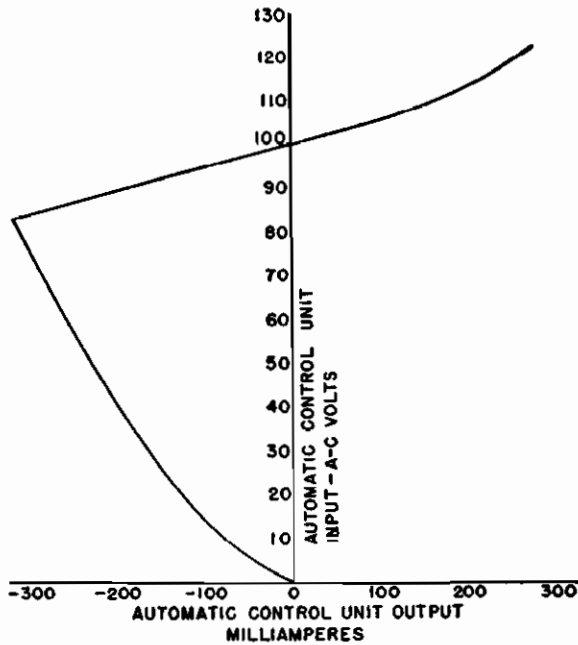

Fig. 40—Typical output curve of automatic control unit as function of a-c voltage.

change in a-c voltage for small changes. The control-field current as a function of the a-c voltage applied to the automatic control unit is shown in Fig. 40. Maximum current in the direction to raise the Rototrol terminal voltage occurs when the a-c voltage is approximately 85 percent of the balance-point voltage. The small current output of the automatic control unit is sufficient to control the Rototrol output over the entire range of the Rototrol capability.

Minimum Excitation Unit—Like other units of the impedance-type voltage regulator, the minimum-excitation unit normally used is comprised of impedance elements.

The minimum-excitation unit establishes a minimum point or limit below which the excitation of the a-c generator cannot be lowered. The minimum point can be a fixed limit or a variable limit. On machines that carry considerable real or kilowatt load it usually is desirable to make the minimum limit vary approximately directly proportional to the kilowatt load, thereby maintaining a margin of excitation current above that at which the machine would pull out of synchronism. Since the main-exciter Rototrol is limited to use with 3600-rpm turbine generators, the minimum excitation unit is of the variable-limit type.

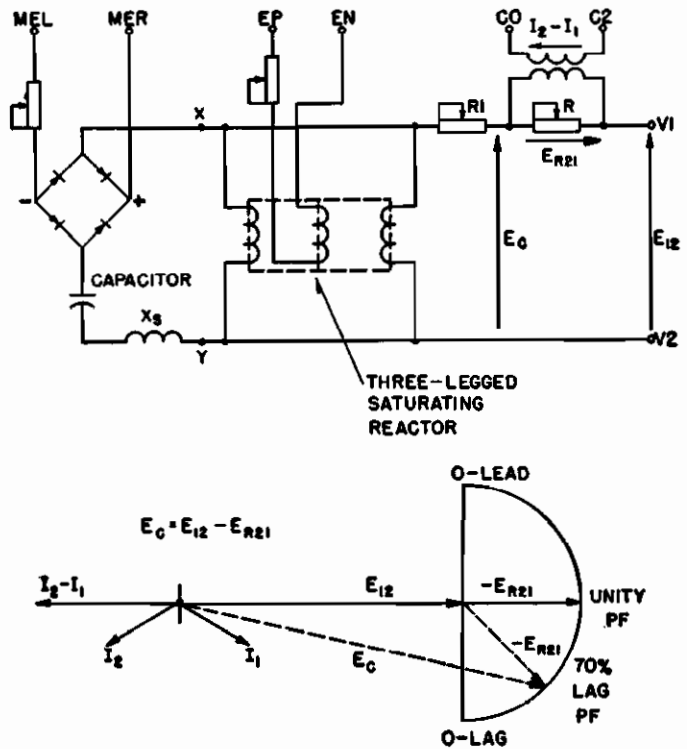

Fig. 41—Schematic diagram of the impedance-type minimum excitation unit and vector diagram showing how variable minimum limit is obtained.

The schematic diagram and vector diagram of the minimum-excitation unit is shown in Fig. 41. A saturable reactor with coils on the three legs of a B-shaped core is used. The two outside legs are connected in parallel, such that at any given instant, both windings produce an a-c flux in the same direction through the center leg of the core. The winding on the center leg is the d-c control coil. The d-c current in this winding controls the saturation of the iron core, thereby controlling the inductance and reactance of the two outer a-c windings. When the d-c control current is low, saturation of the core is slight, and the reactance of the a-c coils is high; and when the d-c current is high, the core has a higher degree of saturation and the reactance of the a-c windings is low.

The center-leg winding is energized by the main-exciter Rototrol output voltage as shown in Fig. 36. When the a-c generator is operating at normal voltage and the excitation voltage is normal, the current in the reactor control winding is relatively high, and consequently the reactance of the a-c windings is low. A substantial amount of a-c current is allowed to flow through the reactor windings under this condition. The relatively high a-c current through resistor *R1* causes a large voltage drop such that the a-c voltage appearing across *X-Y* is relatively small. When the voltage is low across the series circuit composed of the saturating reactor, capacitor and rectifier, current in the series circuit is substantially zero. However, because of the impedance characteristic of this series circuit, there is a voltage at which the series-circuit current begins to increase rapidly with small increases in voltage.

If for some reason system conditions should cause the voltage regulator to introduce current into the control field

of the Rototrol to reduce the excitation voltage, the current in the reactor control winding is also reduced. The reactance of the a-c windings increases, and the current through resistor $R1$ is reduced, causing less voltage drop in the circuit and increasing the voltage across $X-Y$. If the voltage across $X-Y$ rises to the conducting point of the series circuit, a-c current increases sharply in this circuit, and this current rectified is supplied to the minimum excitation control field of the Rototrol exciter. The minimum excitation control field is the limits field in Fig. 36. The direct current supplied to the minimum excitation control field is in the direction to raise the excitation voltage, and the minimum excitation unit thus begins to regulate for a preset minimum excitation voltage to keep the circuit of the unit balanced. When system conditions cause the automatic control unit to increase the excitation above that provided by the minimum excitation unit, the regulator again takes control and holds the voltage for which it is adjusted.

The variable minimum excitation limit is obtained by the compensating circuit shown in the left-hand portion of Fig. 41. The voltage E_{12} across terminals V1-V2 is held constant by the automatic control unit under balanced load conditions. A compensating voltage that is a function of line currents I_2-I_1 is added vectorially to E_{12} such that the a-c voltage applied to the saturating reactor is equal to E_C . The currents I_1 and I_2 in the vector diagram of Fig. 41 are drawn for the unity power factor condition and the resulting magnitude of E_C is represented by the vector drawn with a solid line. If the magnitudes of the line currents are held constant and the power factor changed to 70 percent lagging, the voltage E_{R21} is shifted such that the magnitude of E_C becomes that represented by the dotted vector. Thus, the magnitude of the voltage E_C is dependent on the magnitude of the in-phase component of the line current, and hence varies with the kilowatt load on the generator. The locus of the magnitude of E_C for a particular magnitude of current at various power factors is represented by the semi-circle as shown. Therefore, since the voltage input to the saturating reactor is a function of the kilowatt load, the voltage across $X-Y$ applied to the series circuit also varies with kilowatt load. The minimum excitation limit becomes a variable quantity dependent upon the kilowatt load of the generator.

The individual and combined volt-ampere characteristics of the saturating reactor, capacitor and resistance (equivalent resistance of the reactor, rectifier and load) are shown in Fig. 42 (a). As the voltage across $X-Y$ is increased, the combined characteristic shows that the circuit conducts practically no current until the voltage E_1 is reached. The current then undergoes a large increase to the value I_1 . When the volt-ampere characteristic of the resistor $R1$ is included, the combined characteristic is modified to that shown in Fig. 42 (b). The sudden large increase in current shown when voltage E_1 is reached in Fig. 42 (a) is eliminated, but the current increases rapidly and linearly with increase in voltage in the range above E_1 . The practical operating range of the unit is determined by the intersection of the capacitive reactance line X_C with the saturating reactor line X_S . Two ratings of minimum-excitation units are available; one giving an operating range

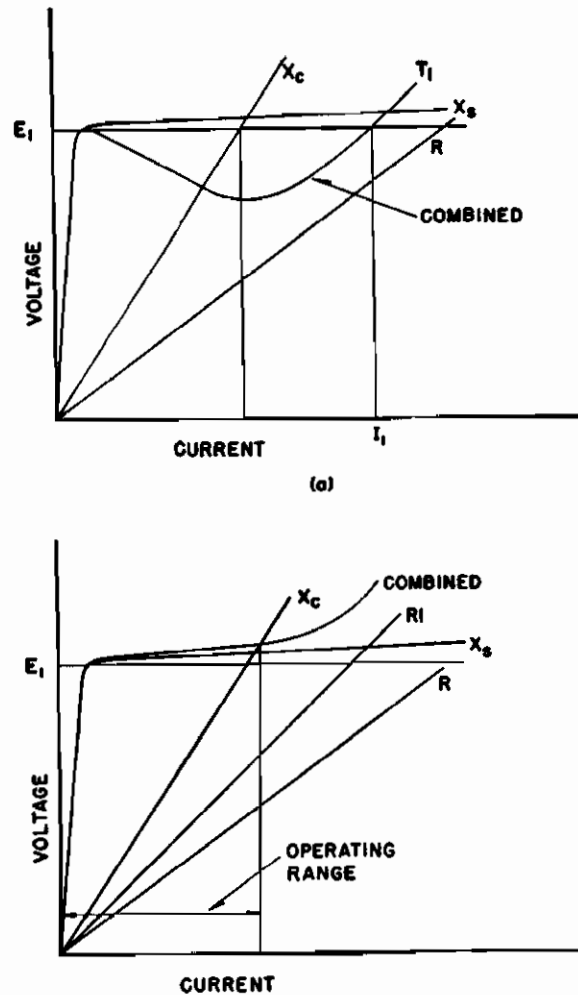

Fig. 42—Volt-ampere characteristics of individual components of minimum excitation unit and combined volt-ampere characteristic.

- (a) Effect of $R1$ omitted.
 (b) Effect of $R1$ included.

of 0-300 milliamperes, and the other giving an operating range of 0-750 milliamperes. The unit having the larger operating range is used with the main-exciter Rototrol.

Manual Control Unit—The manual control unit used with the main-exciter Rototrol excitation system of Fig. 36 is a bridge-type circuit as shown in Fig. 43. Such a circuit is required to reverse the direction of current in the control field as required to raise or lower the Rototrol voltage. In addition, the unit is a d-c voltage regulator in itself, maintaining essentially constant main-exciter voltage and constant a-c generator voltage for a given load.

The bridge circuit consists of two fixed resistors, a potentiometer and two selenium rectifiers connected as shown. The main exciter terminal voltage is applied across two terminals of the bridge and the control field of the Rototrol is connected across the other two terminals. The exciter terminal voltage is adjusted by changing the position of the potentiometer. The selenium rectifiers form the controlling element of the bridge circuit since the voltage drop in this leg of the bridge is practically independent of

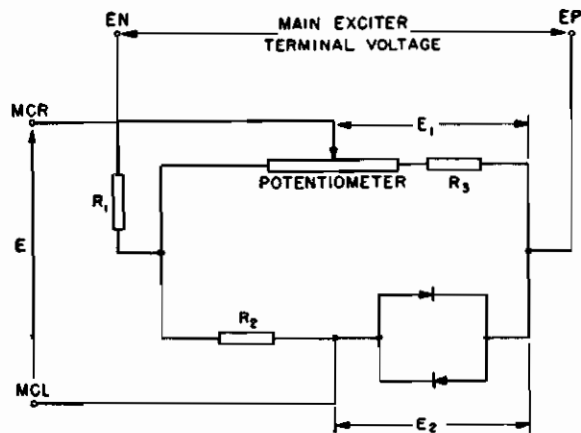

Fig. 43—Schematic diagram of the impedance-type regulator manual control unit.

the current through the rectifiers, and will remain substantially constant. Thus the voltage E_2 in Fig. 43 can be considered constant.

For a given setting of the potentiometer, the bridge circuit is balanced when the voltage E_1 is equal to E_2 and under this condition there is no current in the Rototrol control field. If the main exciter voltage should increase for any reason, the current through the bridge increases, which increases the voltage drop E_1 so that MCR is positive with respect to MCL. Current then flows in the control field in a direction to reduce the exciter voltage until the bridge circuit is again balanced. For a drop in exciter voltage, the control field current would be in the raise direction. Thus, the a-c voltage may be adjusted for any value from zero to maximum, and the manual control unit holds the excitation voltage constant.

24. Main-Exciter Rototrol Generator Excitation System

The Rototrol with its two stages of amplification can be built with large power output capabilities while the control field energy requirements are sufficiently small to be supplied by instrument transformers. Also, since the Rototrol is a high-speed machine with air-gap dimensions the same as any other form of d-c machine, it can be direct-connected to the shaft of a turbine generator. The direct-connected main-exciter Rototrol is a step toward simplification of turbine generator construction, operation and maintenance by completely eliminating the pilot exciter. The circuit of the main-exciter Rototrol excitation system is that shown in Fig. 36.

The effect on the main-exciter Rototrol of induced field current caused by changes in generator load was discussed in Sec. 10. Evidence of the importance of this effect and illustration of the comparative performance of the main-exciter Rototrol excitation system is given in Fig. 44. The solid line shows the time variation of the a-c generator voltage under control of an impedance-type regulator and a main-exciter Rototrol, and the dashed-line curve shows the variation under control of an indirect-acting exciter-rheostatic type of regulator and a conventional main exciter with 0.5 response ratio. In each case, a three-phase reactance load was suddenly applied to the generator to

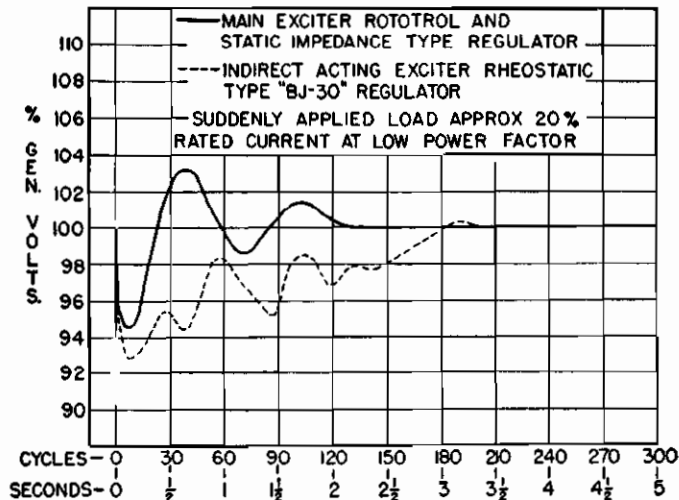

Fig. 44—Voltage-recovery performance of main-exciter Rototrol excitation system compared with performance of conventional main-exciter system under control of BJ regulator. Approximately 20 percent of generator rated amperes at 0 percent lagging power factor added at zero time.

cause approximately 20 percent of rated generator amperes to flow in the circuit. The rapid recovery of the voltage under control of the impedance-type regulator and main-exciter Rototrol is an important factor in maintaining system stability, particularly during the period of overshoot when the generator voltage is greater than 100 percent.

The main-exciter Rototrol excitation system has the advantage of a voltage regulator without moving parts, without contactors, and requiring no large motor-operated main-exciter field rheostat. The overall performance of the system shows marked improvement in voltage dip and recovery time when compared with a conventional main-exciter excitation system. The system also eliminates the use of any pilot exciter.

25. Rototrol Pilot Exciter with Single-Field Main Exciter

The simplest form of an excitation system using a Rototrol pilot exciter is shown in Fig. 45. When the speed of rotation of the main a-c generator is 1200, 1800 or 3600 rpm, the main exciter and Rototrol pilot exciter can be direct-connected to the generator shaft. A second possibility is to have the main exciter mounted on the shaft of the a-c generator and the Rototrol separately-driven by a small motor, the m-g set having sufficient inertia to carry through system disturbances without appreciable speed change. This arrangement might be used where the generator speed is less than 1200 rpm. A third arrangement is to have the main exciter and the Rototrol pilot exciter driven by a motor and operating at 1200 or 1800 rpm. The latter arrangement is applicable with a generator of any speed.

In the conventional excitation system, the pilot exciter is a constant-voltage generator. The Rototrol pilot exciter is a variable voltage pilot exciter and the method of operating the excitation system of Fig. 45 is essentially no different than the operation of conventional exciter-rheostatic

systems, except that no regulator-controlled, motor-operated exciter-field rheostat is used. Variable voltage is supplied to the main-exciter field by the Rototrol pilot exciter, which is connected directly to the field and is under the control of the voltage regulator automatic control unit or the manual control unit.

The voltage regulator potential unit, voltage adjusting unit, automatic control unit and the manual control unit are those described in Sec. 23.

The Rototrol pilot exciter used in this excitation system can provide either one or two stages of amplification, depending on the energy requirements of the main-exciter shunt field. The Rototrol can easily be constructed to provide rates of response and ceiling voltage equal to or in excess of those obtained with conventional d-c machines.

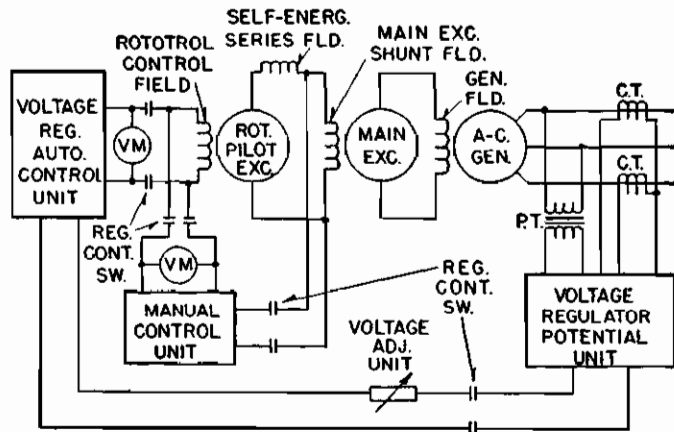

Fig. 45—Excitation system with Rototrol pilot-exciter and single-field main exciter controlled by impedance-type regulator.

The excitation system shown in Fig. 45, therefore, provides performance characteristics at least equal to those obtained with conventional excitation systems.

The Rototrol pilot exciter in Fig. 45 supplies all the excitation requirements of the main exciter. In this respect this system is identical with exciter-rheostatic systems using pilot exciters. The essential advantage is the elimination of the comparatively complicated exciter-rheostatic regulator with its moving parts and elimination of the motor-operated main-exciter field rheostat. As is the case with the exciter-rheostatic excitation system, loss of the pilot exciter through a short circuit or open circuit causes loss of excitation on the a-c generator.

26. Rototrol Buck-Boost Pilot Exciter

The buck-boost Rototrol excitation system using a two- or three-field main exciter, as shown in Fig. 46, offers a number of advantages over the single-field main exciter system described in Sec. 25. In the system of Fig. 46, the Rototrol pilot exciter operates in a different manner from that in Fig. 45.

The operation of the three-field main exciter was described in Sec. 6. The Rototrol buck-boost pilot exciter supplies the proper voltage to field 2 of the main exciter to control the output voltage. Briefly, the excitation provided by field 1 is set by the operator to give a base ex-

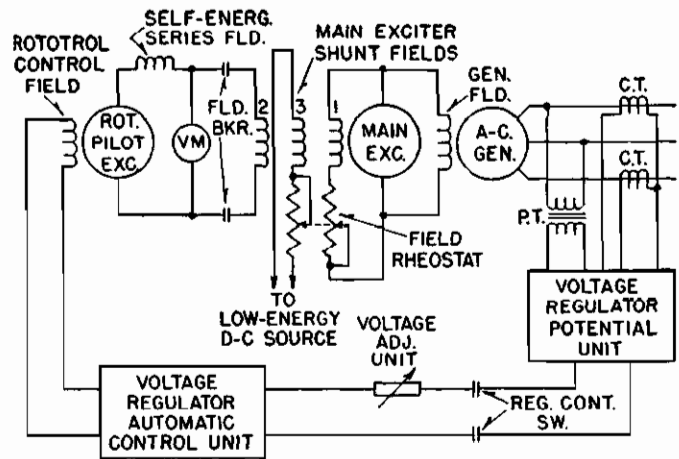

Fig. 46—Excitation system with Rototrol buck-boost pilot exciter and three-field main exciter.

citation in the main exciter, and the excitation provided by field 2 adds to or subtracts from this base excitation to vary the output voltage. Thus the Rototrol must be capable of bucking or boosting the main exciter base excitation to give the necessary range of main exciter voltage. The Rototrol-excited field of the main exciter also acts as a stabilizing field under regulator control.

All of the voltage regulator component parts in Fig. 46 are those described in Sec. 23. The manual control unit is not required, since manual control is obtained by operating the main exciter as a self-excited exciter with a stabilizing field, and voltage control is by means of the shunt-field rheostat.

Since the main exciter base excitation is supplied by the self-excited field, complete excitation is not lost or is the continuity of the load disturbed upon the occurrence of any trouble in the Rototrol buck-boost pilot exciter circuits or in any part of the impedance-type voltage regulator elements. Even in the event of a short circuit or open circuit in the pilot exciter output circuit, the preset base excitation remains rheostat controlled and undisturbed. If a circuit failure occurs when the a-c generator is carrying a load other than that used to determine the rheostat

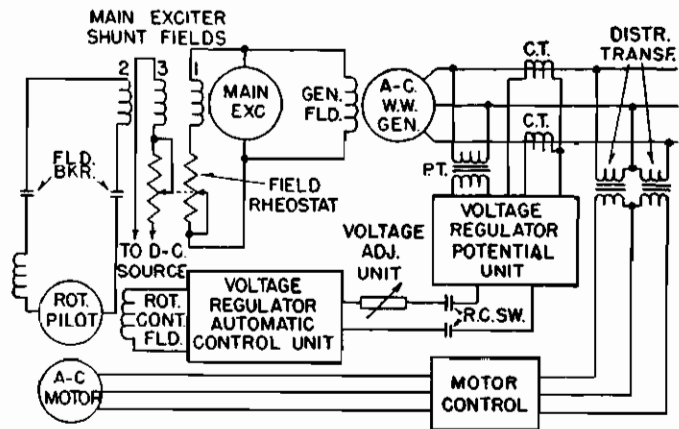

Fig. 47—Excitation system for hydroelectric generator with motor-driven Rototrol buck-boost pilot exciter and three-field main exciter.

setting, the a-c generator continues to carry its kilowatt load, but at a different power factor.

27. Rototrol Excitation for Hydroelectric Generators

It is impractical to direct-connect the Rototrol to the shaft of a waterwheel generator, because of the multiplicity of speeds and sizes involved. The Rototrol pilot exciter, therefore, must be driven by a small motor, introducing the problem of a reliable power supply for the driving motor. The three-field main exciter and Rototrol buck-boost pilot exciter excitation system of Fig. 46 is readily adaptable to use with slow-speed generators and is shown in Fig. 47.

During start-up of the generator when no outside source of supply is available for driving the Rototrol motor-generator set, the main exciter is operated as a self-excited machine and provides excitation for the main generator. As soon as a-c voltage is available, the Rototrol can be started and the voltage regulator placed in service, or operation can be continued under hand control with the operator controlling excitation with the self-excited shunt field rheostat.

Under short-circuit conditions on the a-c system, the

excitation system must be capable of supplying full excitation to the generator field. With the system shown in Fig. 47, this is accomplished by building sufficient inertia into the Rototrol m-g set to carry it through such disturbances with very little change in speed even under severe forcing conditions.

28. Rototrol Excitation for Synchronous Condensers

The Rototrol excitation system for synchronous condensers is similar to that shown in Fig. 47 for waterwheel generators. However, in the usual case, the main exciter for the condenser is also motor-driven so that the motor supply circuit has to be modified to supply sufficient power for the motor-generator set. Electrically, the circuit is the same as Fig. 47, but the main and pilot exciters are normally on the same shaft and driven by a large motor.

Where some form of current limit is desired as discussed in Sec. 22, a static current-limit device can be used with the Rototrol excitation system. The circuit of the current-limit unit is similar to that of the minimum excitation unit shown in Fig. 41. The rectified a-c load current of the condenser is used to energize the center or control winding of the three-legged reactor, and to control the magnitude

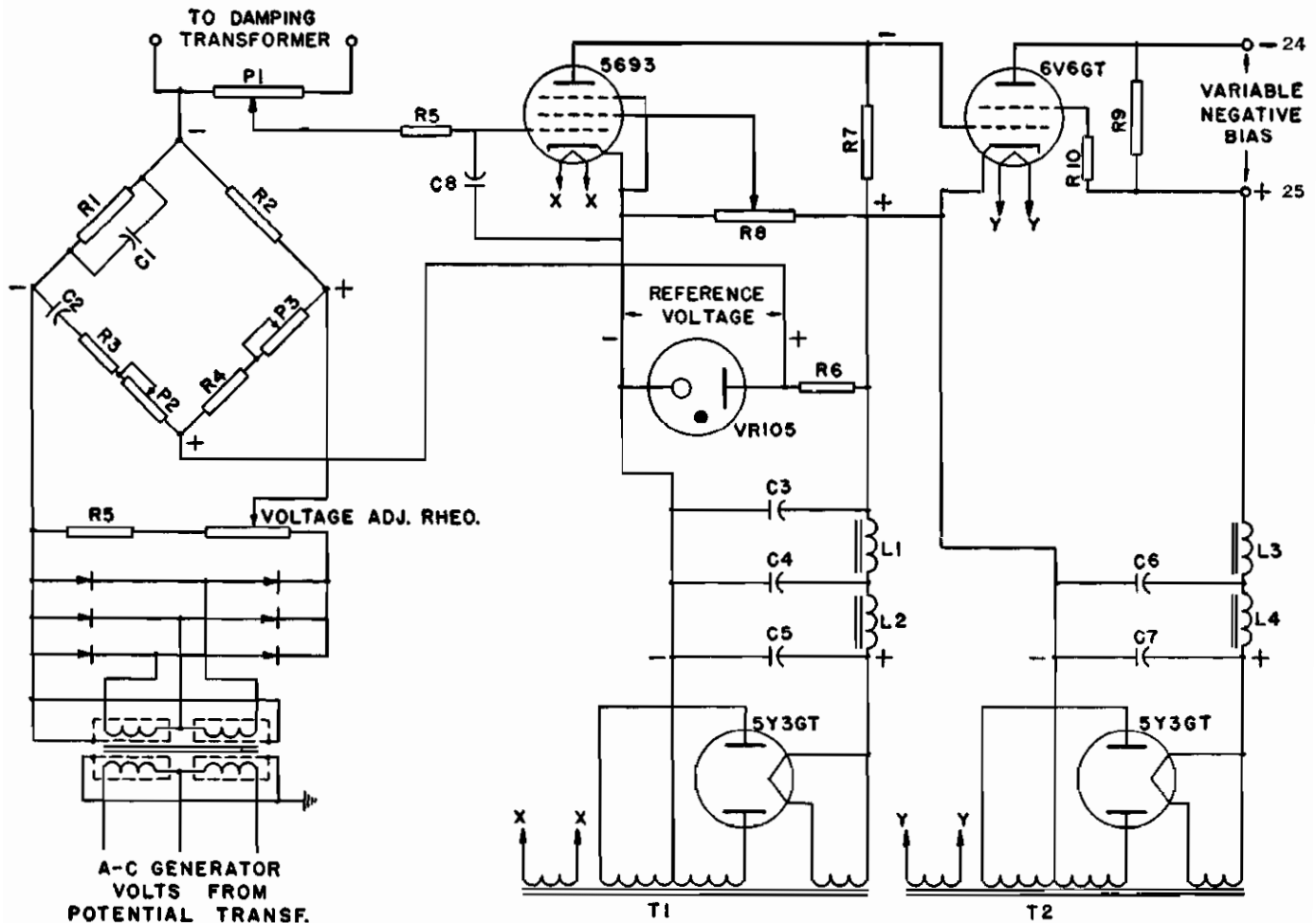

Fig. 48—Schematic diagram of the electronic generator voltage regulator. The variable output appearing across terminals 24 and 25 can be used to control the firing point of an electronic main exciter or can be adapted to control a Rototrol excitation system.

of the voltage applied to the series reactor-capacitor-rectifier circuit. At a certain magnitude of a-c current, the series circuit begins conducting a rapidly increasing current, which is applied to the limits field of the Rototrol. The current in the limits field is in the direction to lower the excitation voltage. Should the control field be conducting current in the raise direction, the combined effect of the two fields is such that the excitation voltage is held constant at the limiting value. Time delay can be provided in the limiting circuit to enable full forcing of the condenser excitation during transient overloads.

29. Electronic-Type Voltage Regulator

Electronic-type voltage regulators are available in many different forms, a typical one being shown in Fig. 48. This particular regulator is used with the electronic main exciter in Fig. 23, but it can be modified for use with Rototrol excitation systems.

A d-c voltage proportional to the average three-phase a-c generator voltage is obtained from a three-phase bridge-type rectifier, the output of which is applied to a voltage-adjusting rheostat and a modified Wein bridge-type filter. The bridge, comprising resistors $R1$, $R2$, $R3$ and $R4$, capacitors $C1$ and $C2$ and potentiometers $P2$ and $P3$, filters the 360-cycle ripple voltage in the d-c output of the rectifier. Thus, the output of the bridge circuit, which is the input to the regulator, is a smooth d-c voltage. The bridge-type filter provides a high degree of filtering without adding unduly long time constants to the regulator input circuit.

The generator voltage regulator consists of two d-c amplifiers and a reference voltage. Regulation is obtained by comparing the rectified generator terminal voltage with the reference voltage. The first d-c amplifier is a high-gain voltage amplifier using a 5693 tube, which is an industrial-type tube with characteristics the same as a type 6SJ7 tube. The output of the voltage amplifier is fed into a power amplifier using a 6V6GT tube. The high-gain voltage stage gives the regulator its high degree of sensitivity and the power amplifier supplies the variable negative bias voltage for controlling the thyatron firing tubes in Fig. 23.

A full-wave rectifier (5Y3GT tube) is used to supply the plate voltage of the 5693 tube. The rectified output of transformer $T1$ is fed into a two-section condenser input filter giving a smooth d-c voltage with polarities as indicated. The d-c reference voltage is obtained from the voltage drop across a type VR-105 voltage regulator tube connected in series with resistor $R6$ across the d-c power supply. The reference voltage is also a smooth d-c voltage that remains constant for wide variations of supply voltage.

The rectified generator voltage is connected differentially with the reference voltage and applied to the grid circuit of the 5693 tube. This circuit can be traced from the grid of the tube through the grid resistor $R5$ to the negative side of the rectified generator voltage; from the positive side of the rectified generator voltage to the positive side of the reference voltage; and from the negative side of the reference voltage to the cathode of the 5693 tube. The amplified voltage from the 5693 tube appears across the load resistor $R7$ with polarities as shown and this voltage drop is applied

to the grid of the 6V6GT tube. The grid circuit of the 6V6GT tube can be traced from the grid through resistor $R7$ to the cathode. The variable negative d-c voltage output of the regulator is obtained across the load resistor $R9$ of the 6V6GT tube and applied to the grid circuits of the thyatron firing tubes in Fig. 23.

Under balanced conditions when the a-c generator voltage is equal to the regulated value, the grid of the 5693 tube is established at a particular bias voltage depending on the magnitudes of the reference voltage and the rectified a-c voltage. This grid bias establishes the current in the 5693 tube and the drop across $R7$, which in turn establishes the grid bias of the 6V6GT tube. Current in the 6V6GT tube is thus fixed, as is the drop across load resistor $R9$. The voltage output is constant as long as the a-c generator voltage is equal to the regulated value.

Should the a-c generator voltage increase above the normal value, the differential connection of the rectified generator voltage and the reference voltage makes the grid bias of the 5693 tube more negative than previously, which reduces the current in the tube and in resistor $R7$. The lower voltage drop across $R7$ reduces the negative bias voltage on the grid of the 6V6GT tube and causes an increase in current through the tube and load resistor $R9$. Thus, the negative voltage output across terminals 24 and 25 is increased. Reference to Fig. 24 shows that the increase in negative-bias voltage on the thyatron firing tubes causes an increase in the angle of grid delay, which reduces the main-exciter voltage. In a similar manner, low a-c voltage causes the grid bias of the 5693 tube to be less negative than previously, which causes a reduction in the voltage across terminals 24 and 25 and a consequent reduction in the thyatron firing tube angle of grid delay.

REFERENCES

1. Quick-Response Excitation, by W. A. Lewis, *The Electric Journal*, Vol. 31, August 1934, pp. 308-312.
2. Determining the Ratio of Exciter Response, by A. van Niekerk, *The Electric Journal*, Vol. 31, September 1934, pp. 361-364.
3. The Exciter-Rheostatic Regulator, by A. G. Gower, Jr., *The Electric Journal*, Vol. 32, February 1935, pp. 73-75.
4. The Generator Rheostatic Regulator, by A. G. Gower, Jr., *The Electric Journal*, Vol. 32, April 1935, pp. 143-144.
5. Recent Developments in Generator Voltage Regulators, by C. R. Hanna, K. A. Oplinger and C. E. Valentine, *A.I.E.E. Transactions*, Vol. 58, 1939, pp. 838-844.
6. Static Voltage Regulator for Rototrol Exciter, by E. L. Harder and C. E. Valentine, *A.I.E.E. Transactions*, Vol. 64, 1945, pp. 601-606.
7. The Multistage Rototrol, by M. M. Liwshitz, *A.I.E.E. Transactions*, Vol. 66, 1947, pp. 564-568.
8. Two-Stage Rototrol for Low-Energy Regulating Systems, by A. W. Kimball, *A.I.E.E. Transactions*, Vol. 66, 1947, pp. 1507-1511.
9. Rototrol Excitation Systems, by J. E. Barkle and C. E. Valentine, *A.I.E.E. Transactions*, Vol. 67, 1948, pp. 529-534.
10. Main Exciter Rototrol Excitation for Turbine Generators, by C. Lynn and C. E. Valentine, *A.I.E.E. Transactions*, Vol. 67, 1948, pp. 535-539.

APPLICATION OF CAPACITORS TO POWER SYSTEMS

Author:

A. A. Johnson

I. SHUNT CAPACITOR FUNDAMENTALS

THE function of a shunt capacitor applied as a single unit or in groups of units is to supply lagging kilovars to the system at the point where they are connected. A shunt capacitor has the same effect as an overexcited synchronous condenser, generator or motor. It supplies the kind of kilovars or current to counteract the out-of-phase component of current required by an induction motor as illustrated in Fig. 1.

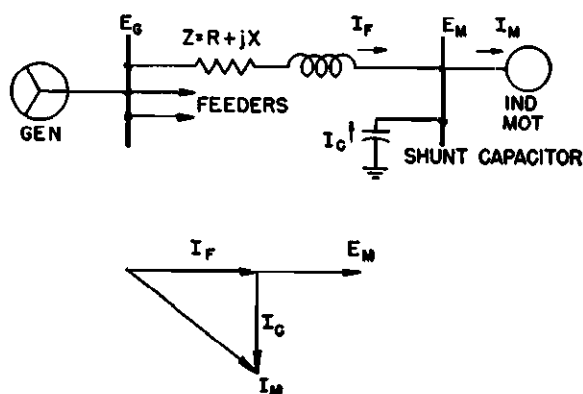

Fig. 1—Shunt Capacitors supplying kvar required by an induction motor.

Shunt capacitors applied on the load end of a circuit supplying a load of lagging power factor have several effects, one or more of which may be the reason for the application:

1. Reduces lagging component of circuit current.
2. Increases voltage level at the load.
3. Improves voltage regulation if the capacitor units are properly switched.
4. Reduces I^2R power loss in the system because of reduction in current.
5. Reduces I^2X kilovar loss in the system because of reduction in current.
6. Increases power factor of the source generators.
7. Decreases kva loading on the source generators and circuits to relieve an overloaded condition or release capacity for additional load growth.
8. By reducing kva load on the source generators additional kilowatt loading may be placed on the generators if turbine capacity is available.
9. To reduce demand kva where power is purchased. Correction to 100 percent power factor may be economical in some cases.
10. Reduces investment in system facilities per kilowatt of load supplied.

The shunt capacitor affects all electrical equipment and circuits on the source side of where they are installed. If the capacitor kvar is small, say ten percent of the circuit rating, it is usually sufficient to make an analysis on the circuit involved for the application. However, where the capacitor kvar is large, its effect on each part of the system back to and including the source should be considered.

In determining the amount of shunt capacitor kvar required, it must be recognized that a voltage rise increases the lagging kvar in the exciting currents of transformer and motors. Thus, to get the desired correction some additional capacitor kvar may be required above that based on initial conditions without capacitors. If the load includes synchronous motors, it may be desirable, if possible, to increase the field currents to these motors.

Shunt capacitors are applied in groups ranging from one capacitor unit of 15 kvar to large banks of these standard units totaling as much as 20 000 kvar. Many small banks of 45 kvar to 360 kva are installed on distribution circuits. Banks of 520 kvar to about 3000 kvar are common on distribution substations of moderate size. Larger banks of 5000, 10 000 and 15 000 kvar are in service in a number of larger substations. Usual voltage ratings of capacitor banks start at 2400 volts and range upward for groups of capacitors connected in series for 46 kv. Consideration is being given to voltages up to and including 138 kv. This is feasible provided the bank is sufficiently large in kvar.

1. History

Shunt capacitors were first applied for power-factor correction about 1914. Their use, however, was limited during the next twenty years because of high cost per kvar, large size and weight. Prior to 1932 all capacitors employed oil as the dielectric. At about this time the introduction of chlorinated aromatic hydrocarbon impregnating compounds (askarels) and other advances in the capacitor construction brought about sharp reductions in size and weight. As shown by Fig. 2 the present weight per kvar is less than 5 pounds compared with over 20 pounds in 1925.

Before 1937 practically all capacitors were installed indoors in industrial plants. Extensive utility use started after the appearance of outdoor units, which eliminated steel housings and other accessories. By 1939 capacitor costs had been reduced almost proportionately with weight and they had been proved in service. Starting in 1939 and continuing to the present, capacitor use has increased phenomenally year by year, as shown in Fig. 2. The acceptance of capacitors has been due to the following:

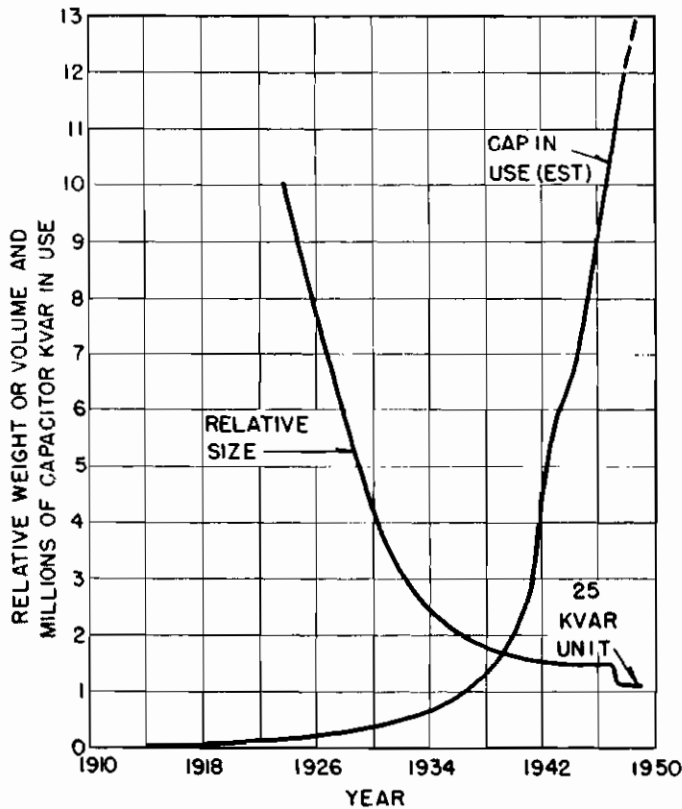

Fig. 2—Evaluation of the size and use of Shunt Capacitors.

1. Reduction in selling price.
2. Improved design and manufacturing methods resulting in small size and weight.
3. Development of outdoor, pole-type units and standardized mounting brackets.
4. Reduction in failures.
5. Better understanding of system benefits that accrue from their use.
6. By force of circumstances, during the war emergency of 1939 to 1945, manufacturing facilities for capacitors were more available than other means of supplying kilovars. Also less critical material was required for capacitors than for other kvar generators.

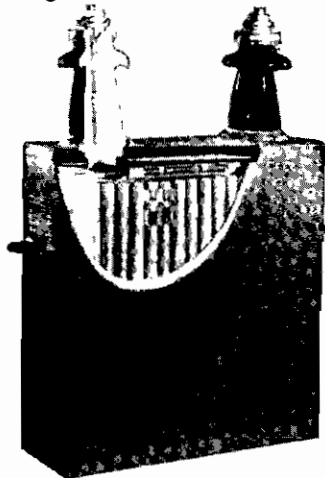

Fig. 3—Cut-away view of 25 kvar 2400 volt outdoor capacitor unit.

7. Due to the large volume of production during the war and since, the economics of using capacitors is favorable.

2. Capacitor Failure Rates

To evaluate the operation and economics of shunt capacitors, it is helpful to predict the number of unit failures that may occur. Not only do unit failures mean the loss of the units but also, under certain conditions a unit failure may damage other good units. Prediction of failures can be based on past experience, such as given in Curve A, Fig. 4. This curve gives cumulative unit failures per 1000 units in service regardless of how or where they are installed or how they are protected. Curve B represents unit failures of small groups of capacitors distributed over a system without lightning protection and subject to

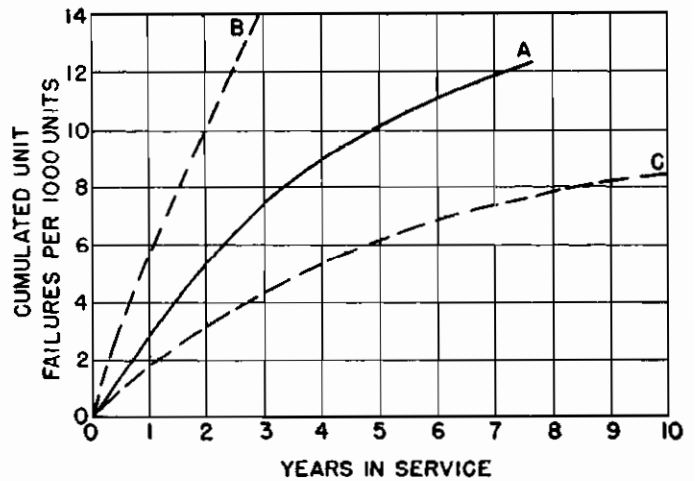

Fig. 4—Failure rate of shunt capacitors.

- A—Average of all types of installations.
- B—Average of unprotected, exposed installations.
- C—Average of well protected larger installations.

other hazards. In view of the benefits a performance as given by Curve B has been considered economical and satisfactory. Curve C represents performance of large banks of capacitors where careful attention has been given to operating conditions and protective devices. For such performance each unit should be inspected and tested at the installation to weed out units damaged in transportation. Individual capacitor fuses are also essential for best performance as discussed later under Capacitor fusing.

3. Fundamental Effects

To illustrate the effects of shunt capacitors, assume that a 100-kva circuit or piece of apparatus has to carry 100 kva at various power factors. By adding shunt capacitors at the load, the kva from the source is reduced materially. The lower the load power factor, the more effective the capacitors are. This situation is illustrated in Fig. 5.

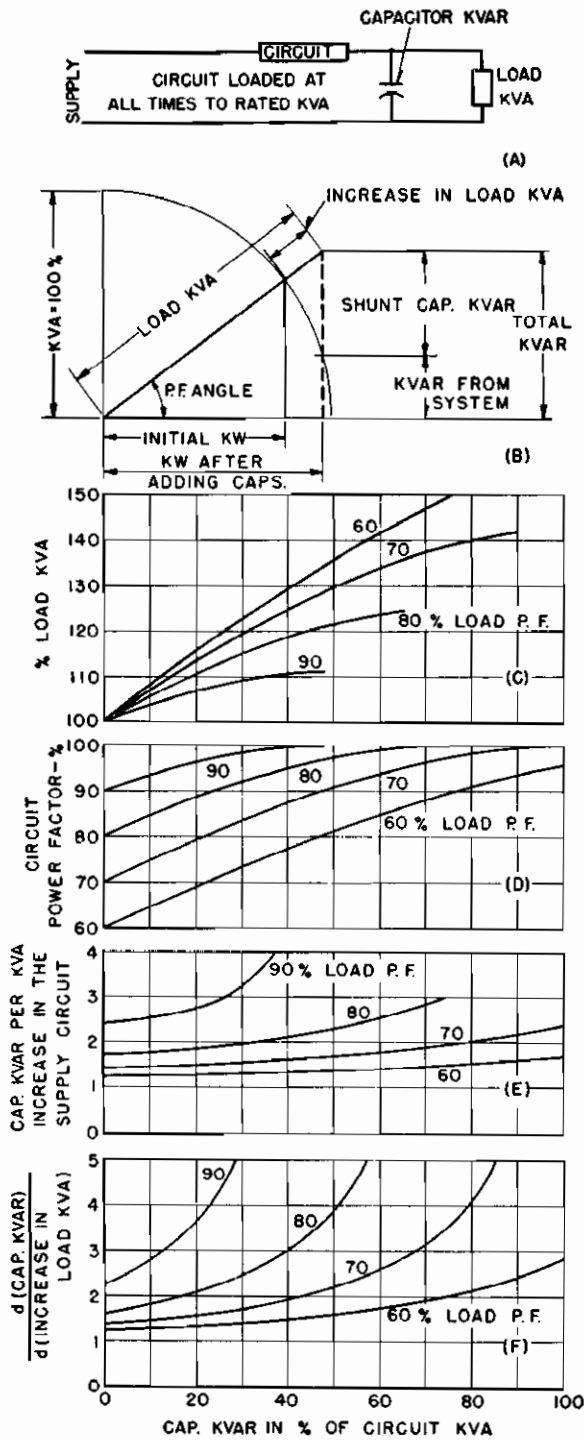

Fig. 5—Fundamental effects of shunt capacitors on power circuits.

Increasing the capacitors lessens the current carried by the supply circuit from the source (Fig. 5(D)), up to the ultimate point at which capacitors supply all of the kilovars required by the load and the circuit supplies only the kilowatt component. For a constant load in the circuit, adding various amounts of capacitors allows the useful load to be increased. By adding 40 kva of capacitors to a 100-kva load of 70 percent power factor, the load can be increased from 100 kva to about 124 kva, as Fig. 5(C) sug-

gests. (If the load should be 10 000 kva at 70 percent power factor, then adding 4000 kvar of capacitors permits the kw to be increased from 7000 to 8700 without increasing the circuit loading above 10 000 kva. The load kva can thus be increased to 12 400 kva at 70 percent power factor.)

Shunt capacitors can be viewed in two lights. Adding capacitors releases circuit capacity for more load, and adding capacitors relieves overloaded circuits.

The capacitor kvar per kva of load increase, Fig. 5(E), is of particular interest, because multiplying this quantity by the cost per capacitor kvar, the product is the average cost of supplying each additional kva of load. This cost, neglecting other advantages of the capacitor, can be compared with the cost per kva of increasing the transformer or supply circuit rating. Thus if the load power factor is 70 percent and a capacitor kvar of 40 percent is added, the capacitor kvar per increase in kva of the load is 1.65. If capacitor cost is \$7.00 per kvar, then the increase in ability to supply load is obtained at a cost of 1.65 times \$7.00 or \$11.55 per kva. The incremental cost of adding transformer capacity may be much greater per kva of increased capacity.

The same data apply equally well to any equipment other than transformers in which current might constitute a limiting factor such as generators, cables, regulators, as well as transmission and distribution lines.

In the example taken (Fig. 5) as the load through the transformer approaches unity power factor, smaller and smaller incremental gains in load are obtained for incremental increases in capacitor kvar. The incremental capacitor kvar required for an increment in kva of the load is Fig. 5(F). Expressed mathematically, the ordinate in this

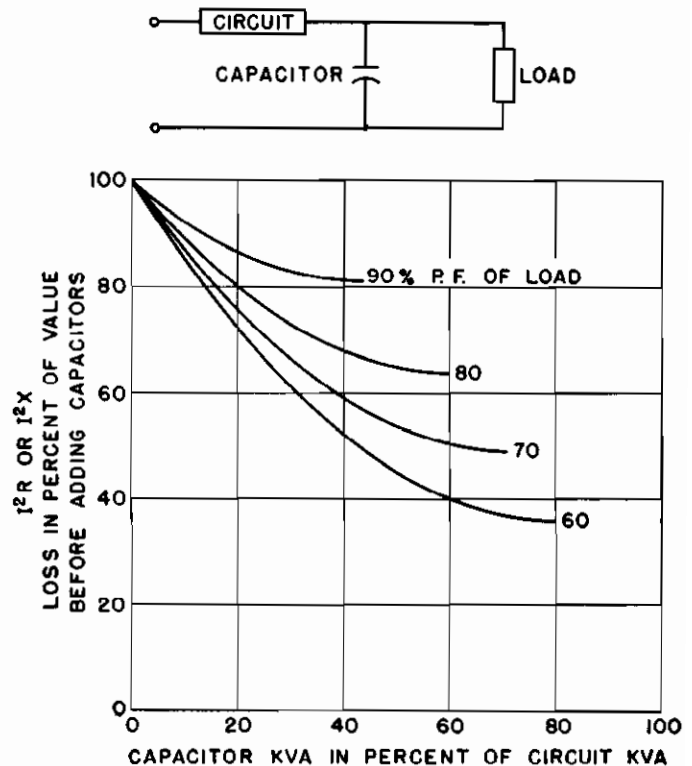

Fig. 6—Reduction in losses in the source circuit to shunt capacitors.

curve is equal to $\frac{d(\text{Cap. kvar})}{d(\text{Increase in load kva})}$. These curves show that the final increment is attained at much greater expense than the initial increment.

Capacitors applied to a given load reduce the I^2R and I^2X loss in the supply circuit in accordance with Fig. 6. For a 70 percent power factor load with 40 kvar of capacitors added for each 100 kva of circuit capacity, the I^2R and I^2X loss will be 59 percent of its former value. This loss in the particular circuit supplying the load can be calculated directly and may be a big factor, particularly if the circuit impedance is high. The resistance and reactance losses are also reduced in all circuits and transformers back to and including the source generators.

To illustrate the effect of shunt capacitors applied to a large load, the curves in Fig. 7 are shown where it is assumed that the load bus voltage is maintained constant at 4160 volts and the generator voltage varies with load.

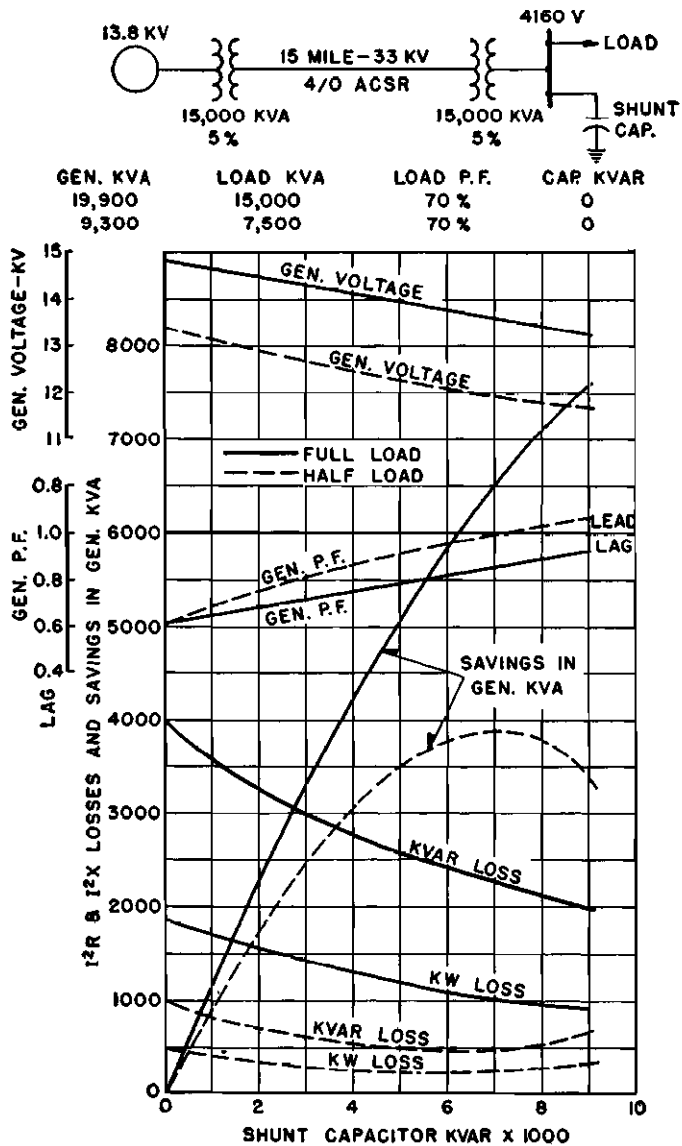

Fig. 7—Effect of various amounts of shunt capacitors at full and half load on a practical system problem.

A 15 000-kva, 70 percent power factor load is supplied over 15 miles of 33-kv circuit. Without shunt capacitors the generators must supply 19 900 kva at a power factor of 62 percent, whereas with the use of 6000 kvar of capacitors the generator power factor is raised to 82 percent. The 6000 capacitor kvar reduces the loading on the generator by 5850 kva, which is almost equal to the capacitor kvar. The I^2R loss in the circuit is reduced by about 800 kw (1900–1100) and the I^2X losses are reduced by about 1600 kvar (4000–2400). Curves are also shown for half load or 7500 kva at 70 percent power factor.

In the case cited, it is desirable to switch part or all of the capacitors off during light-load periods. The voltage and power factor at the generating end determine whether switching in steps should be applied. As Fig. 7 indicates the voltage at the generator would have to vary from 13.8 kv at full load with 6000 kvar of capacitors to 12.1 kv at half load with 6000 kvar of capacitors, assuming a constant voltage of 4160 at the load. By providing 3 steps of capacitors and removing 4000 kvar from the system at ½ load, the remaining 2000 kvar gives a voltage of 12.9 kv at the generator; removing all capacitors from service, a generator voltage of 13.4 kv is required for 4160 volts at the load.

4. Voltage Drop

The voltage drop in feeders or short lines can be expressed approximately by the relation

$$\text{Voltage drop} = RI_r + XI_x \tag{1}$$

where R is the resistance, X the reactance, I_r the power component of the current, and I_x the reactive component

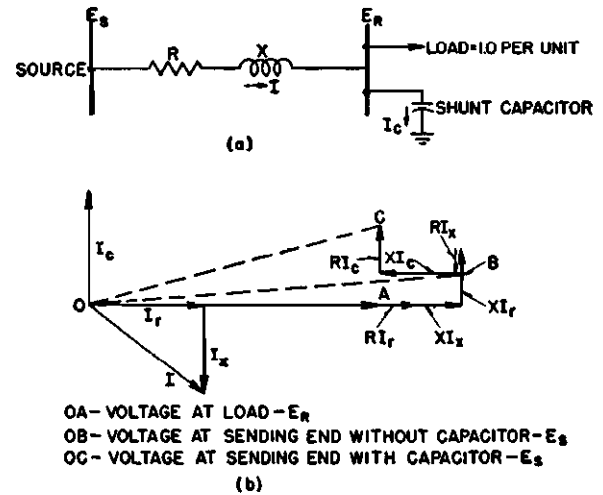

Fig. 8—Effect of shunt capacitors on voltage drop in source circuit.

as shown in Fig. 8. If a capacitor is placed in shunt across the end of the line, the drop immediately decreases or the voltage rises. The new voltage drop becomes approximately:

$$\text{Voltage drop} = RI_r + XI_x - XI_c \tag{2}$$

where I_c is the current drawn by the capacitor. Thus if I_c be made sufficiently large, both the RI_r and the XI_x drops can be neutralized. This expression also shows that if the

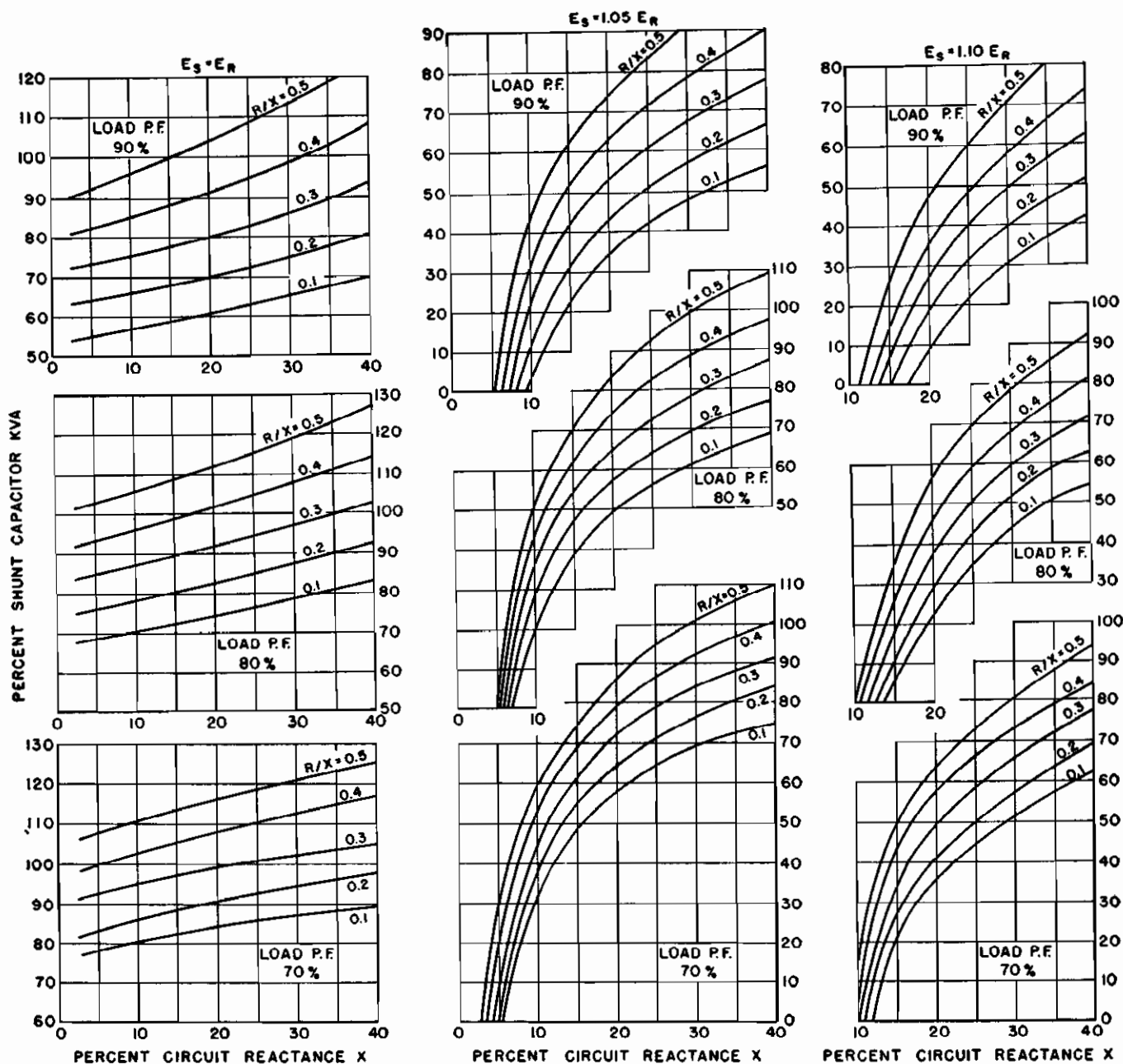

Fig. 9—Shunt Capacitors required for various power factor loads to give 0, 5 or 10 percent voltage drop in the source circuit. All percent values are referred to full load kva as 100 percent base.

voltage drop is compensated at full load with permanently connected capacitors, then at light loads I_r and I_x become smaller and the line is over-compensated because I_o is dependent only upon voltage and not upon load. Regulation of the line is practically unchanged by the capacitor because the capacitor effects an increase in voltage both at light load and at full load. At light loads the voltage rise might be so much in excess of normal as to represent an undesirable or even intolerable condition; a solution is to provide manual or automatic switching to add or remove groups of capacitors as desired.

The curves of Fig. 9 show the amount of shunt capacitor kvar required for loads of three power factors and for 0, 5 and 10 percent voltage drop over the supply circuit. To

illustrate their use, assume a 20-mile, 33-kv line of 2/0 copper conductors which steps down through a 10 000-kva, 7-percent reactance transformer to 13.8 kv. Assume the full load is 10 000 kva at 80 percent power factor. Also assume: line impedance $9.62 + j15.36$ ohms or $0.0886 + j0.142$ per unit on 10 000-kva base; transformer impedance $0.008 + j0.07$ per unit; total impedance $0.096 + j0.212$ per unit.

Therefore, ratio $R/X = \frac{0.096}{0.212} = 0.45$. Referring to Fig. 9 for R/X ratio of 0.45 and a circuit reactance of 0.212 per unit, the shunt capacitor kvar required for a 10 percent voltage drop on the line is 0.54 per unit. In this case 1.0 per unit is 10 000 so 5400 kvar of shunt capacitors are necessary. These data and the capacitor kvar required

for 0 and 5 percent voltage drop are given in the following table. In addition, calculated losses in the circuit are given, as well as the power factors at the sending (E_S) and receiving (E_R) ends of the circuit with the selected capacitor kvar in use. To give a more complete view of the use of Fig. 9 curves the shunt capacitor kvar required for 5000-kva 80-percent power factor load is included in Table 1.

TABLE 1—DATA FOR 20 MILE 33 KV LINE WITH TRANSFORMATION TO 13.8 KV LOAD BUS

Voltage Conditions	Capacitors At the Load		Circuit Loss Kw	Percent Power Factor At	
	Per Unit	Kva		E_S	E_R
10 000 Kva, 80% P.F. Load					
$E_S = E_R$	1.07	10,700	826	95.1 lead	86.2 lead
$E_S = 1.05 E_R$	0.81	8,100	657	99.7 lead	96.7 lead
$E_S = 1.10 E_R$	0.54	5,400	617	97.5 lag	99.7 lag
5000 Kva, 80% P.F. Load					
$E_S = E_R$	1.01	5,050	194	94.0 lead	88.9 lead
$E_S = 1.05 E_R$	0.50	2,500	156	97.9 lag	99.2 lag
$E = 1.10 E$	0.02	100	234	77.5 lag	81.0 lag

For 5000 kva the circuit reactance is 0.106. The ratio R/X remains constant for all loads. Thus the capacitor kvar can be determined, for a given voltage drop in the circuit, for any part of full load by using the per unit reactance based on the partial load.

5. Overvoltage on Capacitors

Capacitors are designed for operation on circuits whose average voltage over a 24-hour period does not exceed the rated voltage by more than 5 percent. The variations above the average may go to 115 percent in the case of 230, 460, and 575 volt capacitors, or 110 percent in the case of higher voltage units. For short periods of time, shunt capacitors can safely withstand higher voltages. For example, during the starting of large induction motors the voltage rating of capacitors applied in shunt with the motor may be as low as 67 percent of the voltage applied to the motor, which means that the voltage applied to the capacitor is 150 percent of its rating. The maximum momentary voltage, such as in welding applications, should not exceed 165 percent of the rated voltage.

TABLE 2—STANDARD CAPACITOR RATINGS

Indoor Type			Outdoor Type		
Volts	KVAR	Phase	Volts	KVAR	Phase
230	5-7½	1 & 3	230	1, 2½, 5, 7½	1 & 3
460	10 & 15	1 & 3	460	5, 10 & 15	1 & 3
575	10 & 15	1 & 3	575	5, 10 & 15	1 & 3
2 400	15 & 25	1 & 3	2400	10, 15 & 25	1 & 3
4 160	15 & 25	1 & 3	4160	10, 15 & 25	1 & 3
4 800	15 & 25	1 & 3	4800	15 & 25	1 & 3
7 200	15 & 25	1	7200	15 & 25	1
7 960	15 & 25	1	7960	15 & 25	1
12 470	15	1	12470	15	1
13 800	15	1	13800	15	1

Note: 25 KVAR Units are only single phase

6. Standard Ratings and Tests on Capacitors

Table 2 gives the standard ratings of capacitor units for indoor and outdoor types. Table 3 gives the standard ratings of indoor and outdoor housed capacitors. Table 4 gives the factory test voltage which are applied to capacitors.

The average operating loss for capacitors, in kw, is one-third of one percent of the kvar rating. Each capacitor has a built-in high resistance device which automatically discharges the capacitor for safety. The ambient temperature

TABLE 3—STANDARD RATINGS FOR INDOOR AND OUTDOOR HOUSED CAPACITORS BANKS VOLTAGE AND KVAR RATINGS

230 V	460-575 V	2400-4160 V	4800-7200-7960 12,470-13,800 V	
15	30	30 600*	90	600*
30	60	45 900*	180	900*
45	90	60 1500*	360	1500*
60	120	90 2100*	540	2100*
90	180	135 2700*	720	2700*
135	270	180 3300*	1080	3300*
180	360	270 4200*	1260	4200*
270	540	360	1440	5100*
360	720	540	1800	
540	1080	720	2160	
630	1260	1080	2520	
		1260		

*Using 25 KVAR Units

TABLE 4—FACTORY TEST VOLTAGES ON CAPACITORS

Voltage Rating of Capacitors	Terminal-to-Terminal Test Voltage	Terminal-to-Ground Test Voltage	
		Indoor	Outdoor
230	500	3000	10 000
460	1000	5000	10 000
575	1200	5000	10 000
2 400	5000	19 000	19 000
4 160	9000	19 000	19 000
4 800	10 000	26 000	26 000
7 200	15 000	26 000	26 000
7 960	16 600	26 000	26 000
12 470	25 000	34 000	34 000
13 800	28 800	34 000	34 000

Application period: 3600 cycles—25 or 60 cycles.

limit covering all capacitors is 40°C; for outdoor open mounted units it is 50°C and for housed units between 40°C and 50°C depending on rack type.

II. CAPACITOR ON INDUSTRIAL PLANT CIRCUITS

A capacitor can be installed in shunt with any load of low power factor to supply the magnetizing current required by the load. The load may be a single motor, or it may be a large industrial plant. The capacitor can be chosen to supply the magnetizing current under peak load conditions, or it can be chosen only large enough to supply the reactive kva hours accumulated over the month. It can be located at the service entrance, thus removing magnetizing current

from the utility system only; or units can be applied to the individual loads, thus removing magnetizing current from the plant circuit also, reducing their loss, and increasing their load capacity, and better maintaining voltage at the loads.

The selection of the capacitor size, and its location is dependent on what is to be accomplished. This varies with

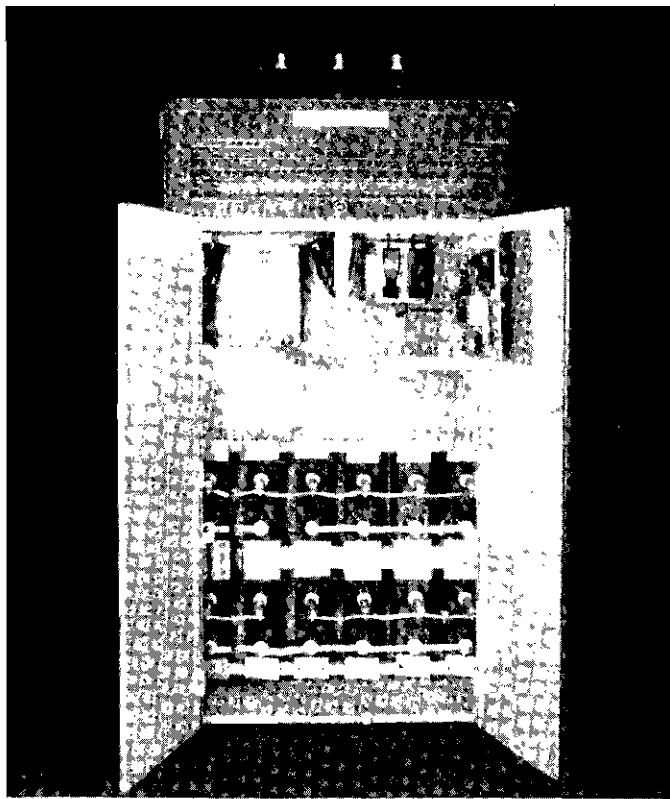

Fig. 10—Enclosed indoor bank of 2400/4160 volt shunt capacitor units with protective screen removed. This is one step voltage control with a RCOC oil contactor.

the power rates, and local conditions. An outdoor bank of capacitor units is shown in Fig. 10.

7. Location of Capacitors

Many factors influence the location of the capacitor such as the circuits in the plant, the length of the circuits, the variation in load, the load factor, types of motors, distribution of loads, constancy of load distribution.

The capacitors can be located in many ways as follows:

- (a) Group correction—at primary of transformer.
- (b) Group correction—at secondary of transformer.
- (c) Group correction—out in a plant, as for example for one building.
- (d) Localized correction on small feeders.
- (e) Localized correction on branch motor circuits.
- (f) Localized correction direct on motors, or groups of motors and switched with the motor.

8. Group Correction

The two principal conditions under which group correction is better are:

1. Where loads shift radically as to feeders.
2. Where motor voltages are low such as 230 volts.

If the power flows from the service entrance to various widely-separated parts of the plant and if the loads shift about a great deal from one feeder to another, the correction may be needed first in one part of the plant and later in another. A centrally-located group capacitor in this case would be an advantage since it would tend to be the same distance from the loads at all times.

If a group capacitor remains connected during light loads the voltage rise is less if this capacitor is installed at or near the transformer bank since the reactance of the plant circuits does not contribute to voltage rise. In this case, application of capacitors to individual motor would represent a larger investment because of the diversity factor. It, therefore, would be better for the operator to switch off portions of the central capacitor to meet the varying load conditions. Exceptions will arise where feeders are long and where the gain from individual load application warrants the greater initial investment in capacitors. Because of the higher cost of low-voltage capacitors their application to 230-volt motor circuits may more than double their cost. This gives considerable advantage to group installation if this can be on the primary side, 2400 to 7200 volts. Capacitors placed ahead of the main bank of transformers do not benefit the transformers; no transformer kva is released. Thus, use of the 230-volt capacitors on the feeders or near the motors is frequently warranted.

9. Localized Correction

Capacitors should be placed as near the load as possible or near the ends of feeders for three main reasons:

1. Losses are reduced in the circuits between the loads and the metering point.
2. Voltage is raised near the loads, giving better motor performance.
3. Capacitor kvar can be reduced automatically as the load drops off by installing some of the capacitors direct on loads so they are switched off with the loads.

The first point can be evaluated easily by investigating the length of the circuits, and the transformations, if any. Whatever gains are found in released transformer capacity and reduction in losses in transformers and circuits are added gains.

The effect of the capacitor is to raise the voltage permanently at any given point where it is connected. This voltage boost, superimposed on the normal voltage, is practically constant from no load to full load on the feeder.

10. Rates and Capacitor

For the purpose of analyzing the different types of rates a typical application can be considered, such as an industrial plant with a day load averaging 960 kw and 67 percent power factor, with peak loads running up to 1200 kw and 75 percent power factor. It is obvious that a large magnetizing current is drawn from the line, and considerable savings can be made by supplying this magnetizing current with capacitors. The size of the capacitor or the merits of their use can only be determined by systematic analysis.

One of the following conditions may exist.

- Power factor is not considered in the rates.
- Power factor is taken into account in demand charge.
- Power factor is checked by test and used to determine energy charge thereafter.
- Power factor is determined by the ratio of kw hours and rkva hours and is used in different ways to calculate the demand charge or energy charge or both.

(a) If power factor is not taken into account in the rate structure, the capacitor can be used only to secure savings in the plant, such as to reduce current in circuits, reduce loads on transformers, and to reduce loads on customer-operated generators. The capacitor should usually be located near the loads of low power factor. The size can be determined by calculating the reactive kva. By using a capacitor large enough to supply all or part of this reactive kva, the current in the circuit is reduced to the desired figure.

(b) If the rates include a kva demand charge, the kva can be reduced by raising the power factor during the demand peak. With a demand of 1200 kw at 75 percent power factor the kva demand is $\frac{1200}{0.75} = 1600$ kva.

If the power factor is raised to 95 percent the demand kva is $\frac{1200}{0.95} = 1260$ kva. The size of the capacitor required to accomplish this is determined from the reactive kva at the two values of power factor as follows.

$$\text{Reactive kva at 75 percent power factor} \\ = \sqrt{1600^2 - 1200^2} = 1060$$

$$\text{Reactive kva at 95 percent power factor} \\ = \sqrt{1260^2 - 1200^2} = 387$$

Kvar rating of capacitor is 1060 minus 387 which equals 673 kvar.

The reduction in the kva demand from 1600 to 1260 may result in either a reduced kva demand charge, or it may reduce the energy charge depending on the rate structure. Some rates involve several energy charges for successive blocks of power, the size of the blocks depending on the kva demand. For example:

$$\begin{aligned} \text{Size of block} &= (70) \times (\text{kva demand}). \\ \text{1st block} &= 5c \text{ per kw hour} \\ \text{2nd block} &= 1\frac{1}{4}c \text{ per kw hour} \\ \text{3rd block} &= 1c \text{ per kw hour} \\ \text{Additional} &= \frac{3}{4}c \text{ per kw hour} \end{aligned}$$

In this case the energy cost is reduced by a decrease in kva demand, because if the blocks are smaller, the lower rate applies to a larger proportion of the energy consumed.

(c) Sometimes a check is made on the average power factor under day load conditions, and the billing thereafter based on this check until some future check is made. The energy charge, or the net billing is adjusted up or down according to this power factor. In such cases it is necessary to determine how this check is to be made, and under what conditions, in order to install capacitors to raise the power factor as high as warranted by the expected savings. Such a capacitor usually is made proportional to day load requirements. In the case above, the day load averaged

960 kw at 67 percent power factor. Assuming this is to be brought up to 95 percent power factor, 720 kva of capacitors are required as follows:

$$\frac{960 \text{ kw}}{67 \text{ percent}} = 1430 \text{ kva}$$

$$\begin{aligned} \text{Reactive kva at 67 percent power factor} \\ = \sqrt{1430^2 - 960^2} = 1035 \text{ kvar} \end{aligned}$$

$$\text{kva at 95 percent power factor} = \frac{960}{0.95} = 1010 \text{ kva.}$$

$$\begin{aligned} \text{Reactive kva at 95 percent power factor} \\ = \sqrt{1010^2 - 960^2} = 315. \end{aligned}$$

Capacitor required is 1035 minus 315 which equals 720 kvar.

(d) A method commonly encountered in industrial plants takes into account monthly power factor obtained by integrating kw hours and rkva hours. Assuming the plant mentioned above is billed for 322 250 kw hours, and that the reactive kva hours equals 346 000. This ratio amounts to a power factor of 68 percent.

Assuming that rates indicate that it will be worthwhile to reduce this rkva hours to a point corresponding to 95 percent power factor.

$$\text{kva hours at 95 percent power factor} = \frac{322\,250}{95} = 339\,000$$

$$\begin{aligned} \text{Reactive kva hours at 95 percent power factor} \\ = \sqrt{339\,000^2 - 322\,250^2} = 106\,000 \end{aligned}$$

Using 730 hours per month the capacitor kvar required equals $\frac{339\,000 - 106\,000}{730}$ or 319 where the kvar meter has

no ratchet so that full credit results even if the power

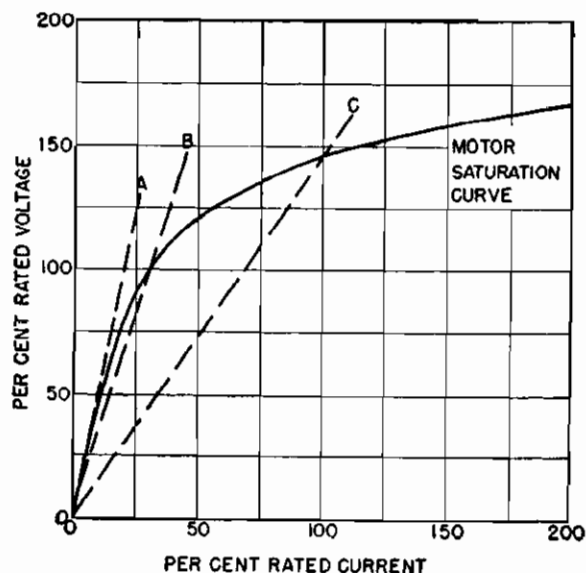

Fig. 11—Self excitation of induction motor with various amounts of shunt capacitors when supply breaker is opened.

- Capacitor current less than motor current at no load rated voltage.
- Capacitor current equal to motor current at no load and rated voltage.
- Capacitor current equal to 100 percent.

factor is leading at times. When the meter has a ratchet the capacitor must be large enough to build up accumulated kvar-hours while the power factor is not leading.

Detail analysis of the load and its variations at each plant, taking into consideration the type of rates, should be made to obtain the greatest benefit from using capacitors. In some cases part of the capacitors may have to be switched off during light load periods to prevent excessive voltage on plant circuits.

11. Capacitors on Induction Motor Terminals

Capacitors frequently are installed across the terminals of induction motors and switched with the motor. The amount of kvar so connected should be limited to values that do not cause excessive voltage at the motor due to self-

TABLE 5—MAXIMUM CAPACITOR KVAR FOR USE WITH OPEN TYPE THREE PHASE 60 CYCLE INDUCTION MOTOR

Motor Rating HP	3600* RPM		1800* RPM		1200* RPM		900* RPM		720* RPM		600* PM	
	Kvar	**	Kvar	**	Kvar	**	Kvar	**	Kvar	**	Kvar	**
10	2.5	9	4	11	4	12	5	17	5	23	7.5	28
15	2.5	9	5	11	5	11	7.5	16	7.5	21	10	26
20	5	9	5	10	5	11	7.5	15	10	20	12.5	24
25	5	9	7.5	9	7.5	10	10	14	10	19	15	22
30	7.5	9	10	9	10	10	10	13	12.5	18	15	21
40	10	9	10	9	10	10	12.5	12	15	16	17.5	19
50	12.5	9	12.5	8	12.5	9	15	12	20	15	22.5	17
60	15	9	15	8	15	9	17.5	11	22.5	14	25	16
75	17.5	9	17.5	8	17.5	8	20	11	27.5	13	30	15
100	22.5	9	22.5	8	22.5	8	25	10	35	12	37.5	14
125	25	9	27.5	8	27.5	8	30	9	40	11	47.5	13
150	32.5	9	35	8	35	8	37.5	9	47.5	11	55	13
200	42.5	9	42.5	8	42.5	8	45	9	60	10	67.5	12

*Synchronous speed
**Percent reduction in line current using capacitor KVAR shown

excitation when the breaker is opened, as Fig. 11 shows. Table 5 gives the maximum recommended capacitor kvar for direct connection to the terminals of induction motors taken from the 1947 National Electrical Code.

III. CAPACITORS ON DISTRIBUTION CIRCUITS

Shunt capacitors offer a convenient and practical means of relieving lines and source equipment of wattless current. They can be installed in relatively small banks and placed near the load points. They usually are arranged in three-phase banks of 45 kvar or more and are distributed over the system at distribution voltage, usually 2400 volts and up, in accordance with local requirements. A 180 kvar installation is shown in Fig. 12. At present it is not economical to apply capacitors on the secondary side of distribution transformers because of the much greater cost. Where the transformers are expensive, such as network units, secondary capacitors may be justified.

The capacity of a distribution feeder can be limited by current or by voltage drop. Where current is the limiting factor, the effect of capacitors in reducing the current is dependent upon load power factor. If the power factor is

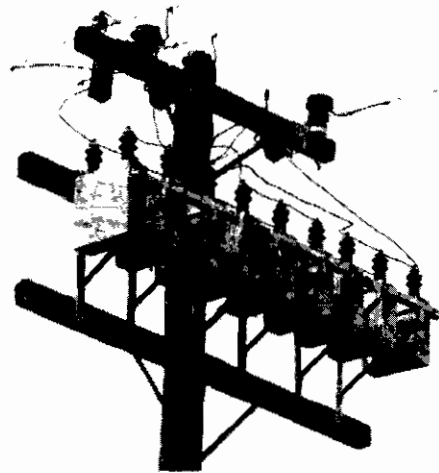

Fig. 12—180 kvar, group-fused, pole-mounted capacitor installation.

low, a large reduction in feeder current or kva can be obtained as indicated by the curves in Fig. 5. If the load power factor is high, shunt capacitors cannot materially change feeder loading. Where voltage is the limiting factor, the capacitor kvar to decrease voltage drop is dependent not only on load power factor but also on the ratio of resistance to reactance of the distribution feeder.

12. Application Factors

In applying shunt capacitors to distribution circuits, certain system data are required.

1. Determine variation, preferably by graphic instruments, of kw and kva on each feeder for a typical 24-hour period at both minimum and maximum daily loads. Usually the minimum reactive kva determines the amount of fixed capacitors to apply without automatic control. This gives about unity power factor at minimum load. In certain cases more fixed capacitor kvar can be applied where voltage conditions at light load permit and where leading power factor is not objectionable.
2. Obtain actual voltage measurements on the feeder during full load and light load at a sufficient number of points to determine the optimum location for capacitors. Fixed shunt capacitors raise the voltage level at the point where they are applied on a given circuit by practically a constant value as given by XI_0 in Eq. 2.

To calculate the voltage at various points on the feeder the circuit characteristics and the load distribution must be known. Where the individual loads are not known, it is reasonable to assume they are proportional to the installed transformer capacity for minimum and maximum feeder load. To simplify calculations single-phase loads can be grouped together to form balanced three-phase loads and adjacent three-phase loads can be grouped to simplify the calculations.

3. It is desirable to supply the kvar required by the load as close to the load as possible to reduce feeder losses. Therefore, capacitor units should be located at load centers or near the ends of feeders. Ideally each load point would have the exact amount of capacitor kvar to supply the necessary load kvar. This, however, is not possible because standard size units must be used. Also it is more economical to use the large size units, namely, 15 or 25 kvar. Over-compensation of feeder branch circuits with capacitors to obtain a higher voltage results in increased copper losses because at lower and lower leading power factors, the current increases.
4. Calculate the released feeder capacity in kw and kva for the capacitor kvar installed. This may involve capacitors installed at several locations on a given feeder. Released substation, transmission, and generator capacity is also immediately available.
5. Calculate the reduction in kw losses and the reduction in kvar losses in the feeder. The effect on all equipment back to and including the source generator should also be evaluated when the total capacitor kvar become appreciable relative to the total source circuit or system reactive kva.
6. Summarize the tangible effects namely, the released feeder capacity, the released capacity back to and including the source generator, the reduction in losses, the effect on voltage, etc. and evaluate the economics to determine whether or not capacitors are justified. Also compare the cost of capacitors with other ways of doing an acceptable job, such as construction of a new feeder, installation of voltage regulators, raising the distribution voltage, etc.

From the above brief summary on applying shunt capacitors to distribution systems, it is evident that no fixed rules can be stated regarding the location of capacitors nor can the degree of importance of each of their effects be stated. Each case is different and requires a complete study in more detail than has been given in this general discussion.

IV. LARGE CAPACITOR BANKS

Shunt capacitors have been applied at substations and at the ends of primary feeders in banks ranging in size up to about 20 000 kvar. The usual large sizes are between 5 000 and 10 000 kvar. A capacitor bank can be switched all in one step, but general practice is to provide switching so that a large bank is connected to the system as needed in several equal steps. Three equal steps are quite common although more or less steps are used, depending on the voltage change per step and the variation in load.

Several typical layouts for switching large capacitor banks are shown in Fig. 13. Fig. 13(a) is for one group of capacitors switched by one automatic circuit breaker. Fig. 13(b) shows four automatic breakers controlling four equal steps in a large capacitor bank. The circuit breakers must be capable of handling short circuit currents. Figure 13(c) shows three equal steps where one automatic breaker supplies the entire bank and trips for short circuits in any one of the three groups of capacitors. Two non-automatic

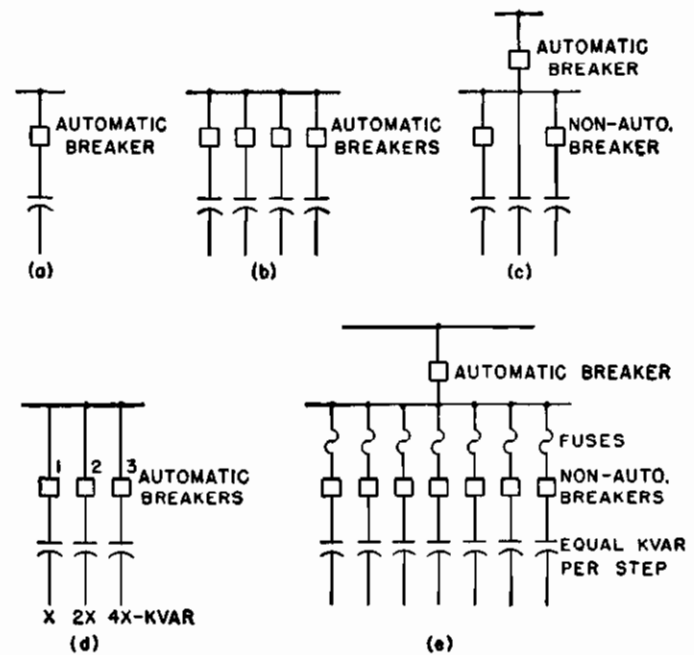

Fig. 13—Schematic arrangements for switching large capacitor banks.

breakers are provided for controlling two steps, the third step being controlled by the main breaker. Figure 13(d) is a scheme in which three groups of capacitors properly proportioned provide seven equal steps. Switch 1 gives $1/7$ of the total; switch 2 gives $2/7$; switches 1 and 2 give $3/7$, and so on for all three switches giving the full capacity of the bank. The disadvantage to this scheme is that during the switching process, large changes of capacitor kvar are made to get from one kvar to another. The worst condition is changing from $3/7$ to $4/7$ of the total kvar where switches 1 and 2 must be opened, thus, disconnecting all capacitors before closing switch 3, or switch 3 must be closed putting all of the capacitors in service before switches 1 and 2 are opened. If the voltage change during these changes can be tolerated, then seven steps in capacitor kvar can be obtained with three circuit breakers. Figure 13(e) is another scheme where one automatic circuit breaker supplies a number of non-automatic breakers which control equal amounts of capacitor kvar. Each non-automatic breaker has a high-capacity fuse that will clear a faulted capacitor group ahead of tripping the main supply breaker. There are many combinations of the use of automatic breakers, non-automatic breakers and high-capacity fuses for capacitor banks that can be applied, depending upon the operating requirements and economics.

13. High Voltage Banks

Supplying kilovars direct to high-voltage circuits is often desirable to meet certain system requirements even though a greater portion of the system is benefited by placing the capacitor nearer the load and on lower voltages. For many years, transformers were used to step down the voltage to the range of the capacitor unit ratings. A few years ago the practice of connecting low-voltage capacitors in series parallel groups and directly to the high-voltage line was

established because they are more economical than the use of high-voltage capacitors or transformers and low-voltage units. One of the first such installation consisted of six groups of 2400-volt outdoor capacitor units operating in series on the phase to neutral voltage of a 24-kv circuit. Each group of 2400-volt units consisted of 10–15-kvar

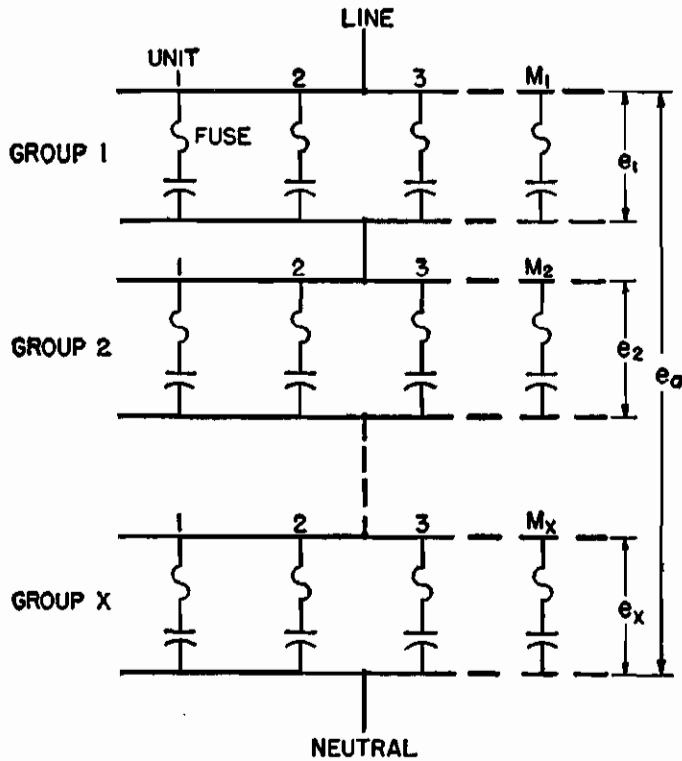

Fig. 14—Connection for fused capacitor units for one phase of a three phase bank. Symbols apply to Eqs. (3) to (11).

- X—Number of capacitor groups in series.
- M—Normal number of capacitor units per group
- N—Number of units out of one group.
- e_1 —Actual voltage across group 1.
- e_{o1} —Rated voltage across group 1.
- e_o —Normal system voltage to neutral.

units in parallel, and these 150 kvar groups were supported on insulators to take care of the line to ground voltage. Figure 14 shows how capacitor units are assembled for one phase of a bank.

Initially, operation of capacitor units in series was looked upon as risky due to the ever-present possibility of subjecting capacitors to overvoltage as a result of changes in voltage distribution either due to a change in impedance of portions of the phase leg or due to grounds at some point on the assembly. Most of these risks are minimized or entirely eliminated, however, when proper thought is given to such factors as fusing, number of units in parallel, connection of one bushing of capacitor to the insulated platform on which it rests and means of detecting unbalance conditions before the unbalance becomes excessive. Each capacitor unit in a high-voltage bank should be provided with a fuse of the indicating type. These fuses need not be of high interrupting capacity because there are always two or more capacitor groups in series, and,

when a unit becomes short circuited for any reason, the current through the fuse is limited. With individual fuses a faulty unit can be located without resorting to the risky procedure of searching for the source of noise or arcing, or making inconvenient tests. It is also easy to make a check and determine if all units in the bank are operating properly. The fuses can be omitted but at a sacrifice in the protection to the capacitor bank.

The number of units in parallel in a single group is important. Several things affect this. First the number should be sufficiently large to insure that the fuse on a single unit blows when the unit becomes short circuited and the fuse is called upon to carry the total phase current. Second, the voltage on the remaining units in a group should not become excessive with the operation of one fuse in a group. If the number of parallel units is too small, the current through the fuse may be so low that it will not blow, or take too long in doing so. An arc of 50 amperes inside a capacitor unit may rupture its case if allowed to continue for a long time and such a rupture may endanger other units in the bank. After considering the size of fuses that must be used to avoid operation on switching transients, and taking into account the arc energy required to rupture the capacitor case, it has been established that the current through the fuse when a unit becomes shorted should

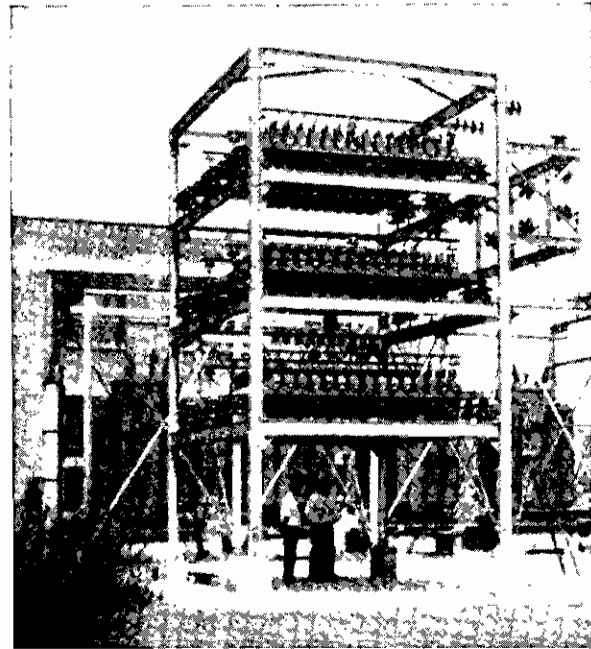

Fig. 15—6000 kvar 34.5 kv outdoor capacitor bank with bus-mounted fuses.

never be less than 10 times the normal capacitor current through the fuse.

It is also desirable to avoid voltages in excess of 110 percent on the remaining units in a group following the operation of one fuse. This assumes that in the case of the minimum size bank not more than one fuse operation is permitted. To accomplish this, periodic checks are necessary.

The amount of current that flows through a fuse when a unit is shorted is also affected by the number of series

groups and whether or not the neutral of the capacitor bank is grounded.

Tables 6 and 7 show the recommended minimum number of fused capacitor units that should be used in parallel for a given number of groups in series in each phase leg, for ungrounded or grounded-wye connections respectively

TABLE 6—UNGROUNDED WYE CAPACITOR CURRENT AND VOLTAGE RELATIONSHIPS WITH SHORTING AND REMOVAL OF ONE UNIT IN ONE PHASE LEG

Number Groups Series	Minimum Units per Group	Current During Fault Through Fuse Times Normal	Voltage on Remaining Units in Group Percent
1	4	12.0	109
2	8	12.0	109
3	9	11.6	109.5
4	9	10.8	110
5	10	11.5	110
6	10	11.2	110
7	10	11.0	110
8	10	10.9	110
9	11	11.9	Less than 110
10	11	11.8	Less than 110
11	11	11.7	Less than 110
12	11	11.6	Less than 110
13	11	11.6	Less than 110
14	11	11.5	Less than 110
15	11	11.5	Less than 110
16	11	11.5	Less than 110

TABLE 7—GROUNDED WYE CURRENT AND VOLTAGE RELATIONSHIPS WITH SHORTING AND REMOVAL OF ONE UNIT IN ONE PHASE LEG

Number Groups Series	Minimum Units per Group	Current During Fault Through Fuse Times Normal	Voltage on Remaining Units in Group Percent
1	1	Line Fault	
2	6	12	109
3	8	12	109
4	9	12	109
5	9	11.2	109.8
6	9	10.8	110.0
7	10	11.7	109.4
8	10	11.4	119.5
9	10	11.2	Less than 110
10	10	11.1	Less than 110
11	10	11.0	Less than 110
12	10	10.9	Less than 110
13	10	10.8	Less than 110
14	11	11.8	Less than 110
15	11	11.8	Less than 110
16	11	11.7	Less than 110

based on meeting the previously discussed requirements. All capacitor units are assumed to be the same voltage and kvar rating.

Very often large banks contain many more than the minimum number of units in parallel. When this is the case, more than one fuse can operate and still not seriously raise the voltage across remaining units. In such cases

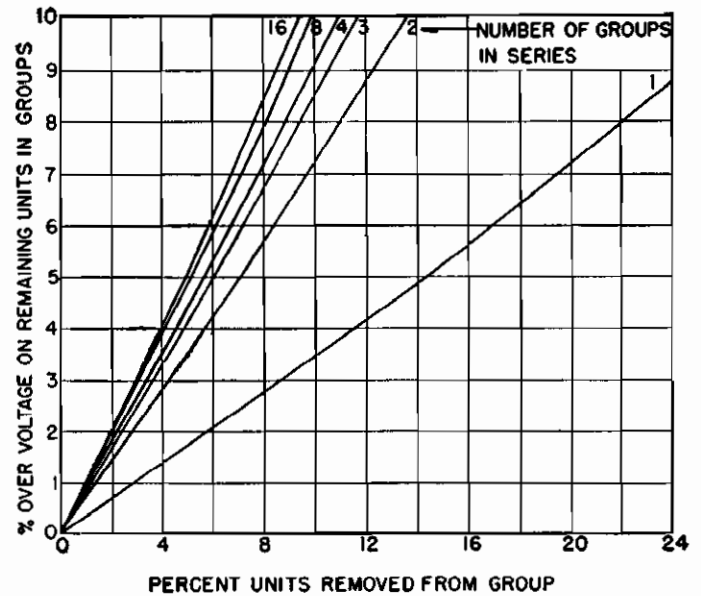

Fig. 16—Ungrounded wye connected shunt capacitor bank. Curves give the percent overvoltage across the remaining units in a group.

periodic checks of fuses are necessary to avoid abuse of good capacitors as result of a faulty one. The voltage across the remaining capacitors can be determined from Tables 6 and 7, the curves of Figs. 16 and 17 or calculated from the equations given below. For all equations the system impedance up to the capacitor bank was neglected.

Refer to Fig. 14 for identification of symbols in the following equations. The equations simplify quickly; all units have the same voltage rating.

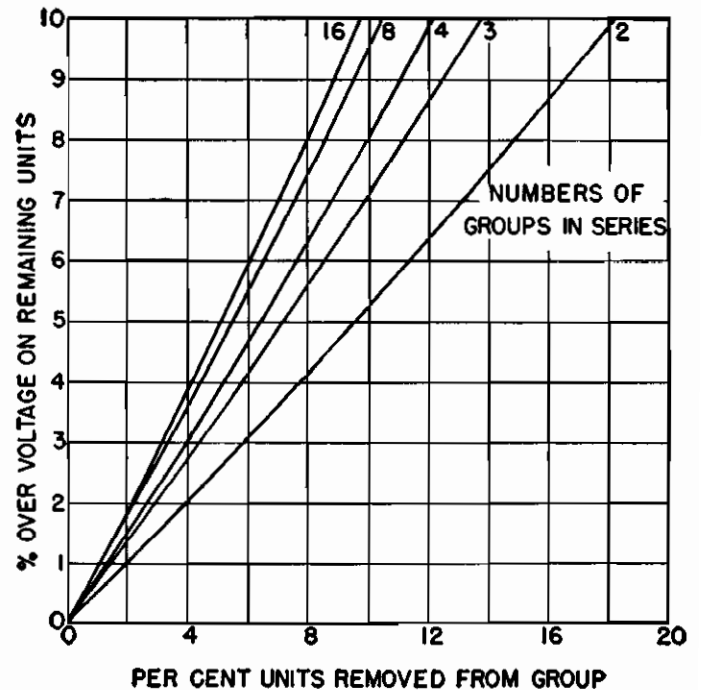

Fig. 17—Grounded wye-connected shunt capacitor bank. Curves give the percent overvoltage across the remaining units in a group.

14. Ungrounded Neutral Capacitor Bank

Normal voltage across group 1 is

$$e_{1N} = \frac{\left(\frac{e_{c1}^2}{M_1}\right)(e_a)}{\frac{e_{c1}^2}{M_1} + \frac{e_{c2}^2}{M_2} + \dots + \frac{e_{cx}^2}{M_x}} \quad (3)$$

With N_1 units removed from group 1, the voltage e_1 across the remaining units is

$$e_1 = \frac{\left(\frac{e_{c1}^2}{(M_1 - N_1)}\right)(e_a)}{\frac{(3M_1 - N_1)(e_{c1}^2)}{3M_1(M_1 - N_1)} + \frac{e_{c2}^2}{M_2} + \dots + \frac{e_{cx}^2}{M_x}} \quad (4)$$

With N_1 units removed from group 1 the voltage shift of the neutral of the capacitor bank e_{No} is

$$e_{No} = \frac{\frac{N_1}{M_1} \left(\frac{e_{c1}^2}{(M_1 - N_1)}\right)(e_a)}{3 \left[\frac{(3M_1 - N_1)e_{c1}^2}{3M_1(M_1 - N_1)} + \frac{e_{c2}^2}{M_2} + \dots + \frac{e_{cx}^2}{M_x} \right]} \quad (5)$$

The current through the fuse for a completely short-circuited capacitor unit in group 1 in times normal operating current is

$$I_t = (M_1) \left[\frac{\frac{e_{c1}^2}{M_1} + \frac{e_{c2}^2}{M_2} + \dots + \frac{e_{cx}^2}{M_x}}{\frac{e_{c1}^2}{3M_1} + \frac{e_{c2}^2}{M_2} + \dots + \frac{e_{cx}^2}{M_x}} \right] \quad (6)$$

15. Grounded—Neutral Capacitor Bank

Normal voltage e_1 across group 1 is same as for ungrounded neutral bank as given in Eq. (3).

With N_1 units removed from group 1 the voltage e_1 across the remaining units is

$$e_1 = \frac{\left(\frac{e_{c1}^2}{(M_1 - N_1)}\right)(e_a)}{\frac{e_{c1}^2}{M_1 - N_1} + \frac{e_{c2}^2}{M_2} + \dots + \frac{e_{cx}^2}{M_x}} \quad (7)$$

The current through the fuse of a completely short-circuited capacitor unit in group 1 in times normal operating current for a grounded-neutral capacitor is

$$I_t = (M_1) \left[\frac{\frac{e_{c1}^2}{M_1} + \frac{e_{c2}^2}{M_2} + \dots + \frac{e_{cx}^2}{M_x}}{\frac{e_{c2}^2}{M_2} + \dots + \frac{e_{cx}^2}{M_x}} \right] \quad (8)$$

16. Two Identical Capacitor Banks with Neutrals Solidly Tied Together and Ungrounded

The normal voltage across any group of capacitors in an installation consisting of two similar groups with the neutrals tied solidly together and ungrounded is e_1 as given by Eq. (3) for any bank. With N_1 units out of group 1 in one bank the voltage across the remaining units in group 1 is

$$e_{1N} = \frac{\left(\frac{e_{c1}^2}{(M_1 - N_1)}\right)(e_a)}{\left(6 - \frac{N_1}{M_1}\right)(e_{c1}^2) + \frac{e_{c2}^2}{M_2} + \dots + \frac{e_{cx}^2}{M_x}} \quad (9)$$

The current in the fuse of a completely short-circuited capacitor unit in group 1 of one bank of two similar banks with the neutrals solidly connected and ungrounded in terms of normal current in one capacitor unit is

$$I_t = (M_1) \left[\frac{\frac{e_{c1}^2}{M_1} + \frac{e_{c2}^2}{M_2} + \dots + \frac{e_{cx}^2}{M_x}}{\frac{e_{c1}^2}{6M_1} + \frac{e_{c2}^2}{M_2} + \dots + \frac{e_{cx}^2}{M_x}} \right] \quad (10)$$

The current in the neutral connection between two similar banks of capacitors, with N units out of group 1 in one bank, in terms of the normal current through one capacitor is

$$I_{No} = \frac{1}{2} \left[\frac{\frac{e_{c1}^2}{(6 - \frac{N_1}{M_1})(e_{c1}^2) + \frac{e_{c2}^2}{M_2} + \dots + \frac{e_{cx}^2}{M_x}}}{\left[\frac{N_1}{M_1 - N_1} \right]} \right] \quad (11)$$

17. Protection of Large Banks of Shunt Capacitors

The usual types of protection for large capacitor banks are:

1. Individual capacitor fuses.
2. Capacitor group (or bank) fuses.
3. Overcurrent relays or trip coils to trip a bank circuit breaker.
4. Potential transformers connected across each phase or each series group per phase of ungrounded wye banks to trip the bank circuit breaker on phase or group voltage unbalance. This scheme can be used for delta or wye grounded-neutral banks that have two or more groups in series.
5. Potential or current transformers connected between the neutrals of two or more wye ungrounded banks to detect unbalance in one bank and operate a relay to trip a single breaker through which all banks, in the protective scheme, are supplied.
6. Potential transformer placed between the neutral and ground of a wye ungrounded bank connected to a grounded system to operate a relay and trip the bank breaker on a shift in the neutral voltage.

Large capacitor banks can be connected in wye ungrounded, wye grounded or delta. However, the wye ungrounded connection is preferable from a protection standpoint. Individual single-phase 15- and 25-kvar capacitor units are protected usually by a fuse whether installed in an outdoor or indoor bank for any type of capacitor connection. For the wye ungrounded system of connecting single capacitor units in parallel across phase-to-neutral voltage the fault current through any fuse is limited by the capacitors in the two sound phases. In addition the ground path for harmonic currents is not present for the ungrounded bank. For wye grounded or delta-connected banks, however, the fault current can reach the full short-circuit value from the system because the sound phases cannot limit the current. Thus, with the wye ungrounded

connection smaller fuses and less material are needed for protecting the capacitors. With two or more groups of capacitors in series per phase, the short-circuit current is limited by the capacitors in the unfaulted group. The capacitor bank should have a protective device to disconnect the bank from the system if individual units become defective thereby causing a bad unbalance of capacitor kvar among the three phases.

Two protective schemes for wye connected ungrounded banks for all voltage classes are shown in Fig. 18. The scheme shown in Fig. 18(a) is preferred because the potential transformers serve the dual purpose of protecting against unbalanced capacitor kvar per phase leg as well as

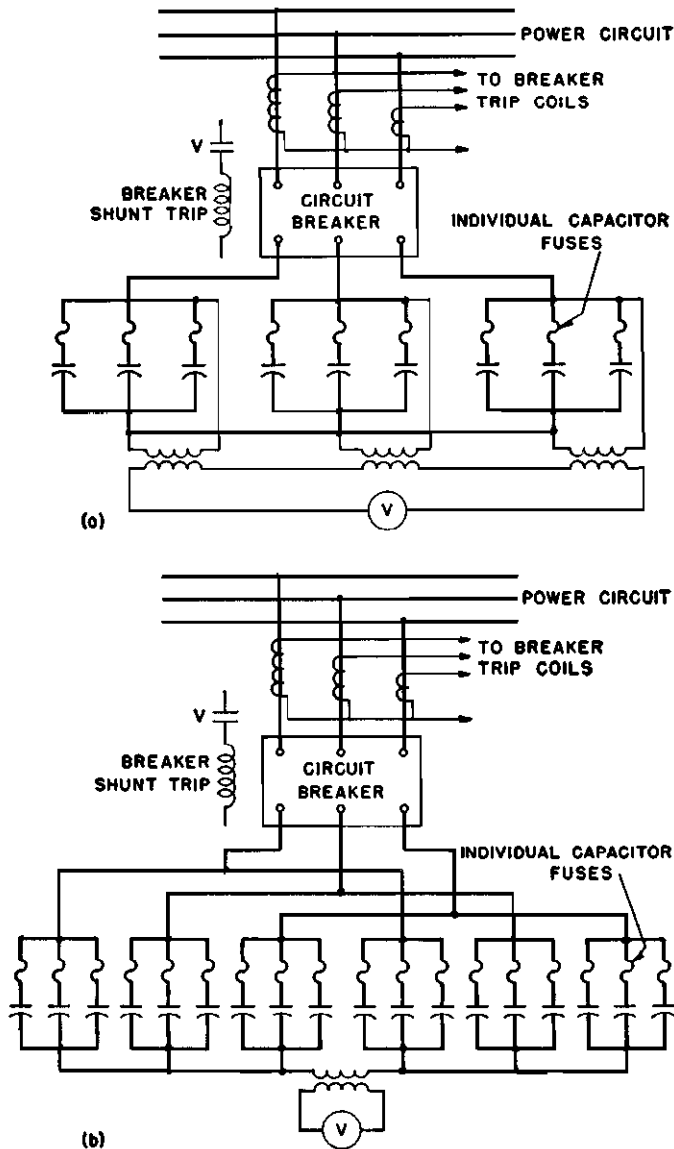

Fig. 18—Two protective schemes for large banks of ungrounded wye-connected capacitors.

- Residual voltage trip in event of unbalance among the three phases due to failure of capacitor units.
- Residual voltage trip in event of unbalance between the two 3-phase groups of capacitors. Current flow between the two groups can also be used for protection.

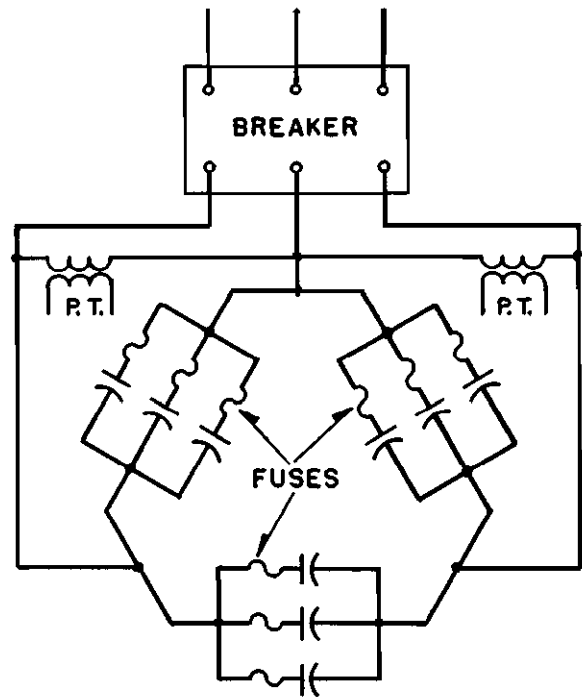

Fig. 19—Delta-connected, fused capacitor units usually used at 2400 volts or less.

providing a discharge path to dissipate quickly charges left on capacitor units when the supply is disconnected. A current or potential transformer connected between the neutral points of two equal parts of a group of capacitors provides protection for unbalanced kvar per phase as shown in Fig. 18(b). In addition, however, two potential transformers connected in open delta should be used on automatically controlled banks across the supply leads to the group to provide a fast discharge path when the capacitors are de-energized. One of the potential transformers can also be used for an indicating lamp to show when the group is energized.

A delta-connected bank of capacitors, Fig. 19, usually applies to voltage classes of 2400 volts or less. Individual capacitor fuses are provided for each unit. If the bank is controlled automatically, potential transformers should be applied across each phase leg to provide fast discharge when the group is de-energized. The individual capacitor units have a very high resistance provided across the terminals inside the case to discharge the capacitors in five minutes after being disconnected from the source. This time of five minutes is considered to be too long for banks that are controlled automatically because when the group is switched on again before the charge is dissipated high transient switching currents result. In special cases such as for indoor capacitor banks, it can be compulsory that potential transformers be applied for rapid dissipation of charges remaining on capacitor units.

18. Capacitor Fusing

General—Each capacitor unit contains a large area of insulation and the probability of unit failures must be recognized even though the record is good, as shown in Fig. 4. When the number of units in a single installation

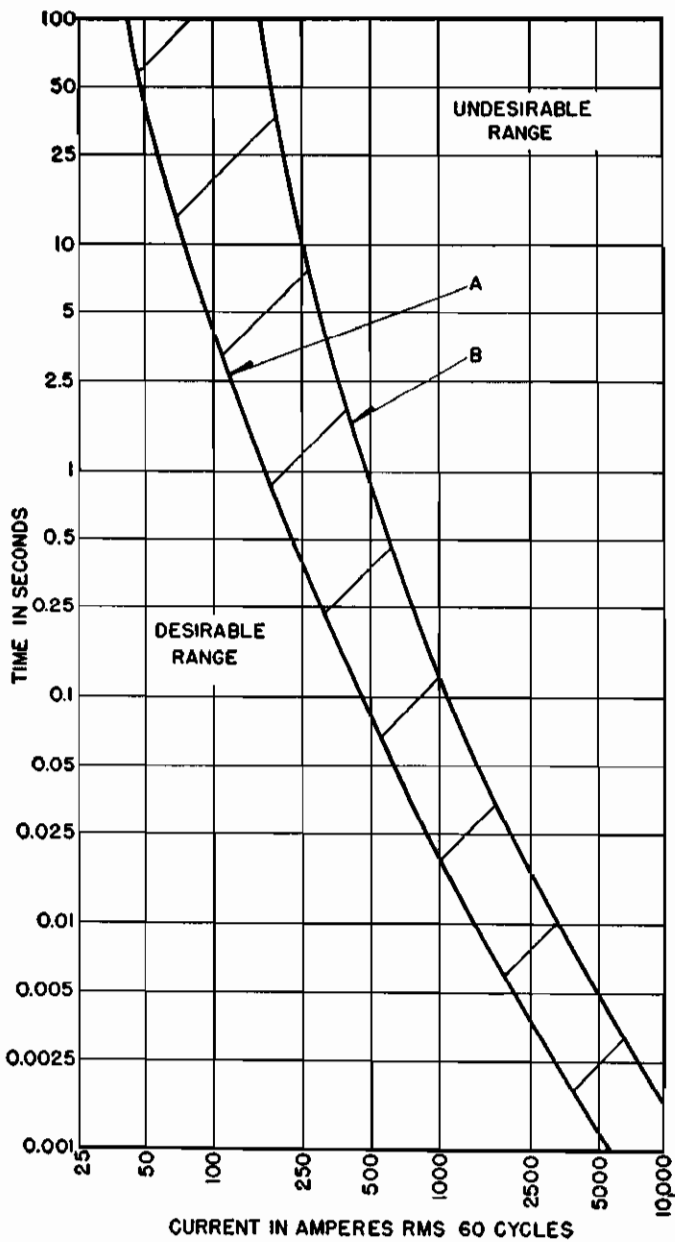

Fig. 20—Capacitor fault current and its relation to case rupture.

Curve A—Where fault currents are cleared in a time to the left of this curve the case is not likely to rupture.

Curve B—Where fault currents are on for a time to the right of this curve the case is likely to rupture with sufficient force to damage other units.

Area AB—Fault currents in this area may open case seams. This area may be used for fuse selectivity with reasonable safety.

is large the probability of a unit failure of insulation is greater. The removal of faulted units is important for the protection of the remaining good units.

About sixty-five percent of existing capacitor kvar on utility systems are "pole type" and usually total about 180 kvar per installation. These are usually on circuits where the fault currents are moderate and group fusing has been satisfactory. When a capacitor unit becomes shorted, it

usually does not result in case rupture or damage to other units.

Large capacitor banks are generally on circuits capable of producing high fault current, and additional problems are created due to the close association of large numbers of capacitor units.

The ability of a short-circuited capacitor to pass current is limited by the current-carrying capacity of the thin aluminum foil that forms the electrode surfaces. If these foils are allowed to carry heavy fault current, the foil may act as its own fuse. This has considerable bearing on the fusing problem because a fault within a capacitor can melt the foil rather easily and the fault tends to clear and sometimes restrike. The presence of other capacitors in parallel with and discharging into the shorted capacitor increases the tendency to melt the fault clear. Under certain conditions the arc restrikes each half cycle, thus allowing the adjacent capacitors to be repetitively charged and discharged. This may damage the current-carrying connections of some adjacent units and cause simultaneous or later failure. The current a capacitor unit can pass before case rupture is likely to occur is shown in Fig. 20. If the fault current in a capacitor is limited to a few hundred amperes, the pressure builds up slowly and many cycles of current flow may be endured before case rupture takes place. When the current exceeds about 3000 amperes a rupture results in mechanical damage to adjacent units and often in short-circuited bus connections; the greater the short-circuit current the more violent the case rupture.

If the arc in a capacitor unit is allowed to persist until the case is ruptured, other units and parts in the bank may be damaged either mechanically or by consequent arcs. It is, therefore, desirable to provide adequate protection against short-circuited capacitor units. The function of this protection is:

- To protect the circuit and capacitor bank so as to minimize the chance of an outage.
- To protect other capacitors in the bank against electrical damage due to current transients.
- To protect the other units in the bank from mechanical damage due to a unit case rupture.
- To minimize the hazard to the operators and maintenance personnel.

Protection Inherent in Breakers—Breakers with overload protection, and adequate interrupting rating protect the circuit, but usually do not protect the capacitors against damage in case of a short-circuited unit, unless supplemented by individual capacitor fuses, or relay means to trip the breaker as a result of current or voltage unbalance. Use of breakers alone, however, does not remove the hazard associated with a bank where unit fault currents are high.

A breaker should be considered primarily as a switching device and circuit protective device, and not as protection against high fault current within an individual capacitor unit. It may, however, be considered as back-up protection in case the individual unit protection or other protection fails.

Group Fusing—A short-circuited capacitor is in reality a conducting path having time-melting character-

istics, which has a bearing on the maximum size of the group fuse. The size of the group fuse is also determined by the normal current of the bank and harmonic currents.

In general, the following rules are recommended for group fusing:

- It is preferable not to apply group fuses greater than 85 amperes in rating (on a 100 per cent rating basis.)
- The circuit is protected adequately by group fuses if they have sufficient interrupting capacity.
- To minimize the danger of mechanical damage, group fuses should be supplemented with individual fuses when the unit fault current is expected to exceed 3000 amperes, even though the group fuse interrupting rating is adequate for the expected fault current.

Large banks of capacitors have been installed with dependence placed solely on group fuses or breakers. Where fault currents are high, the failure of one unit is likely to damage other units in the bank, thereby multiplying the damage considerably. Other units may also fail at a later date when the reasons are not immediately apparent.

Some of these large capacitor banks without individual fuses are wye connected with the neutral ungrounded, or are made up of series groups, so that the problem of high fault currents does not exist. Unbalance in these cases is detected by voltage transformer and relay schemes so as to trip the breaker under abnormal conditions such as might occur if a unit becomes short-circuited. The objection to this arrangement is that it is difficult to identify a defective unit and there is the possibility of electrical damage to parallel units before the breaker de-energizes the bank. Individual capacitor fuses give indication of a blown fuse and give electrical as well as mechanical protection to parallel units.

Individual Fuse—The individual fuse rating is dependent upon the normal current rating of the capacitor unit, harmonic currents and the number of times in rapid succession a fuse must carry discharge current from a good capacitor unit to a defective unit. To provide for the later requirement, the current rating of the fuse is usually at least twice the current rating of the capacitor.

Individual fuses are used primarily to remove units following failure of the dielectric. Since only one fuse is used with each unit, this fuse is not expected to clear for ground faults within the unit. Relaying should be provided where possible to detect ground faults even though their occurrence is very rare.

Individual capacitor fuses should be used, particularly in large banks, so that a faulted unit is disconnected promptly from the circuit for a number of reasons:

- Their current rating is small and coordinated with the time-current characteristics of the capacitor.
- They indicate the defective unit.
- They reduce to a minimum the chance of unit case rupture and subsequent mechanical damage.
- They remove a short-circuited unit before the inside foil material is fused to the point where repetitive clearing creates high transient current in adjacent units.
- They protect units against transient currents set up by parallel arcs in the bank such as bus flashovers, roof bushing flashovers, or failures in potheads or accessories, or arcs in short-circuited units in the bank.

- They permit uninterrupted use of the capacitor bank since a faulty unit need not take the bank out of service.

Table 7 shows there is a minimum number of capacitor units required in parallel per group to give sufficient current for positive operation of an individual fuse on a failed unit. Likewise there is a maximum safe number of individually fused capacitors that can be placed in parallel per group because if a unit fails all other parallel units discharge their stored energy, at high current, through one fuse to the fault. If too many units are in parallel per group, the current is high enough to cause mechanical rupture of the fuse with the possibility of damage to other

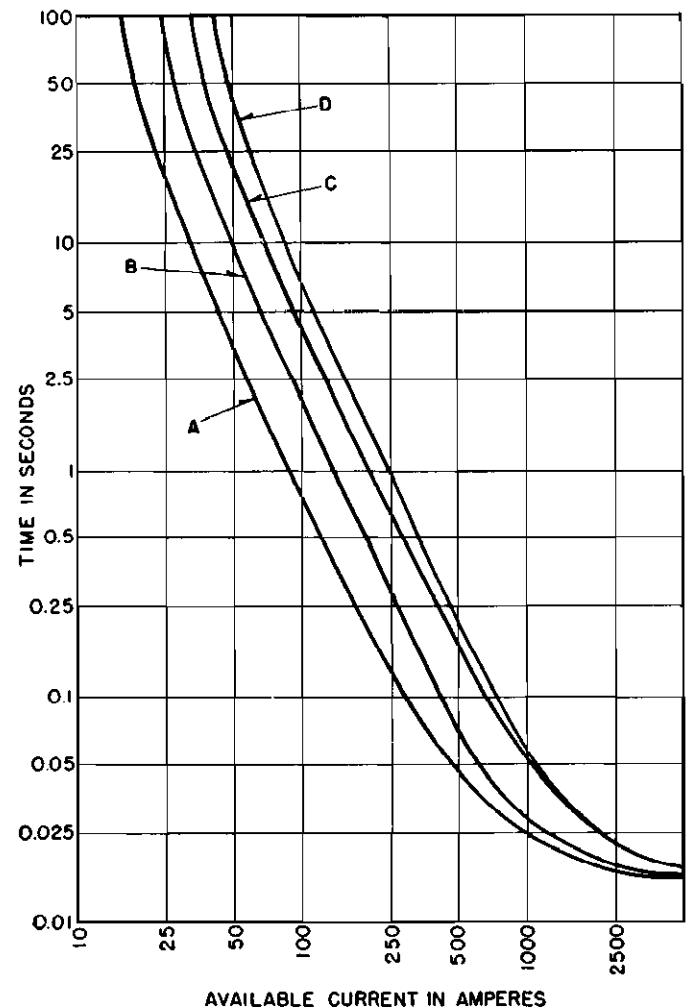

Fig. 21—Typical type BAC capacitor fuse characteristics for use with housed units where the fault current is less than 15 000 amperes from the system.

- Fuse A—4160 volt delta connected 15 kvar units.
4160 volt ungrounded wye 15 kvar units.
7200 and 7960 volt ungrounded wye 15 kvar units.
- Fuse B—2400 volt delta connected 15 kvar units.
2400 volt grounded wye 15 kvar units.
4160 volt delta connected 25 kvar units.
2775 volt ungrounded wye 15 kvar units.
4160 volt ungrounded wye 25 kvar units.
7200 and 7960 v. ungrounded wye 25 kvar units.
- Fuse C—2775 volt ungrounded wye connected 25 kvar units.
- Fuse D—2400 volt delta connected 25 kvar units.
2400 volt grounded wye-connected 25 kvar units.

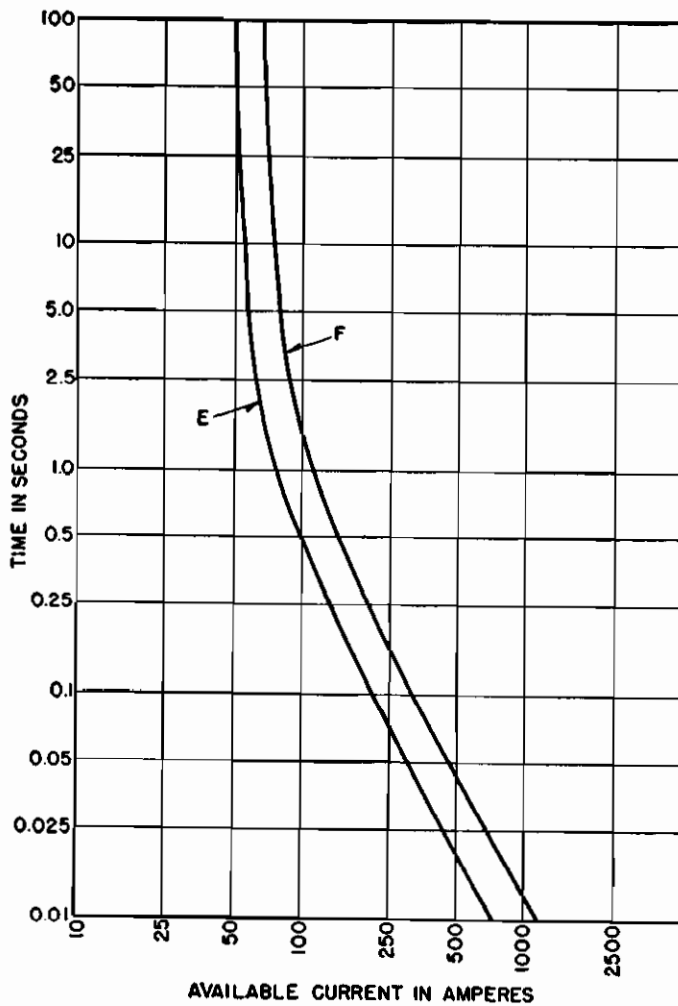

Fig. 22—Typical type CLC current limiting fuse characteristics for use where the fault current is high or in excess of 15 000 amperes from the system.

- Fuse E—2400 volt delta connected 15 kvar units.
2400 volt grounded wye 15 kvar units.
Fuse F—2400 volt delta connected 25 kvar units.
2400 volt grounded wye 25 kvar units.

units. Therefore, on large banks of capacitors, when the number of units in parallel per group exceeds two or three times the minimum required number, special consideration should be given to the application particularly with regard to arrangement. Where such limitations are involved, the bank can be divided into two or more parts where there are two or more groups in series. Lower voltage units with a fewer number in parallel per group with more groups in series may be a solution also.

Individual Fuse Characteristics

- (a) Housed Banks—2400- and 4160-volt delta-connected and 2400-volt wye-connected grounded-neutral.

Housed banks usually contain indoor-type individual unit fuses. Where the fault current is less than 15 000 amperes type BAC fuses are used, the characteristics of which are shown in Fig. 21. Actually the discharge current from the good capacitor units operating in parallel with the faulted unit supplies a considerable portion of the

energy to blow the fuse on the faulted unit. If it were not for the current from the parallel units the system short-circuit current would have to be limited to about 3000 amperes to prevent rupture of the capacitor case. The discharge current from the parallel capacitors is high in magnitude as shown in Fig. 28 and reaches half value in about 0.02 second or less.

Where the fault current exceeds 15 000 amperes from the system, individual capacitor current limiting fuses (CLC) are used, the characteristics of which are shown on Fig. 22.

(b) Housed Banks (Ungrounded Wye)

Housed banks for circuit voltages of 4800 volts and above are usually wye connected with the capacitor neutral ungrounded, whether or not the source neutral is grounded.

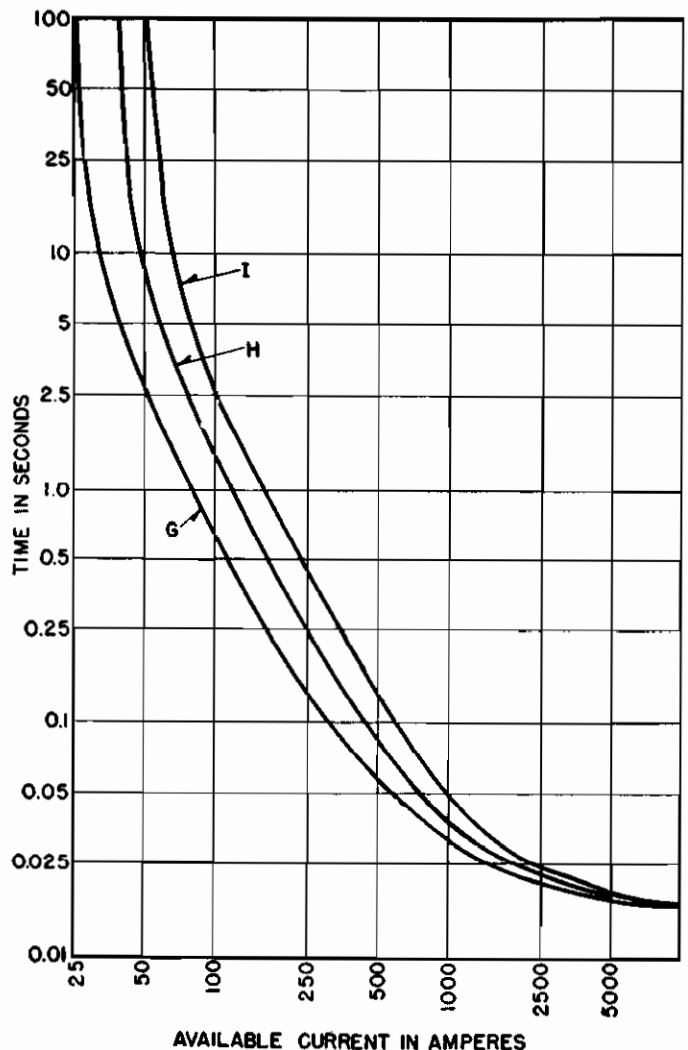

Fig. 23—Typical UT fuse characteristics used on ungrounded wye-connected outdoor capacitor banks.

- Fuse G—4160 volt 15 kvar units
7200 volt 15 kvar units.
Fuse H—2775 volt 15 kvar units.
4160 volt 25 kvar units.
7200 volt 25 kvar units.
Fuse I—2775 volt 25 kvar units.

This arrangement limits fault current and the type BAC fuses are used, the characteristics of which are shown on Fig. 21.

(c) Outdoor Structural Type Banks (Delta or Grounded Wye)

Where the fault current is likely to be high as for a delta connected or grounded wye, outdoor bank current limiting individual fuses (CLC) are desirable. This applies to delta connected 2400 volt banks, wye connected 2400 volt and delta connected 4160 volt banks of capacitors. The characteristics of the fuses are the same as for similar indoor banks as shown on Fig. 22.

(d) Outdoor Structural Type Banks (Ungrounded Wye)

Outdoor structural type banks for voltages of 4800 volts and above are usually wye connected with the neutral of the capacitor ungrounded, whether or not the source neutral is grounded. This arrangement limits fault current and permits fuses of lower interrupting rating. The characteristics for these fuses are given on Fig. 23.

19. Automatic Control for Capacitor Banks

The intelligence required to switch banks of shunt capacitors automatically depends upon the reason for their use. If they are used primarily to control voltage, then the capacitors can be switched on when the voltage is low or off when the voltage is high, and a voltage relay supplies the control. If the system voltage is regulated by other means and the capacitors are used for power-factor correction, then the load kvar or total current must be used as the means for control.

It is always desirable to use the simplest type of control that will accomplish the desired result. Current control is commonly used where the voltage is regulated by other means and the power factor is practically constant through wide variations in load. Kvar control is used where the load power factor varies over a wide range as the load changes.

Whether the control is accomplished by voltage, current, or kvar, the control systems are similar. In addition to the master control relay, other devices are required in the control scheme such as time-delay relays, control switches, etc. For one-step automatic control the master relay energizes the "closing" element of a time-delay relay, and if the master-relay contacts stay closed for the time required for the time-delay relay contacts to make, then the operating circuit is energized and the capacitor breaker closes.

A similar process in reverse trips the capacitor breaker. For a two-step control the sequence is the same as for one-step control except that auxiliary contacts on the No. 1 breaker set up the circuits for the control of the second step. If the No. 1 breaker is closed, the circuit is set up to either trip No. 1 or to close No. 2. The sequence of operation is the same in all cases, that is, No. 1 breaker always closes first and trips last.

For more than two-step control, each additional breaker, by means of auxiliary contacts, sets up the control circuits for the next operation whether it be to add or remove capacitor kvar. The control circuits become numer-

ous and involved, but their operation is accurate, reliable, and thoroughly proved by many applications.

Where the need for capacitor kvar follows a fixed schedule, the capacitors can be switched by a time relay that initiates *on* or *off* at predetermined times.

20. Inrush Current

When the first step of a capacitor bank is energized, it is possible for a large instantaneous current from the system to flow. Curves in Fig. 24 show for several line-to-line

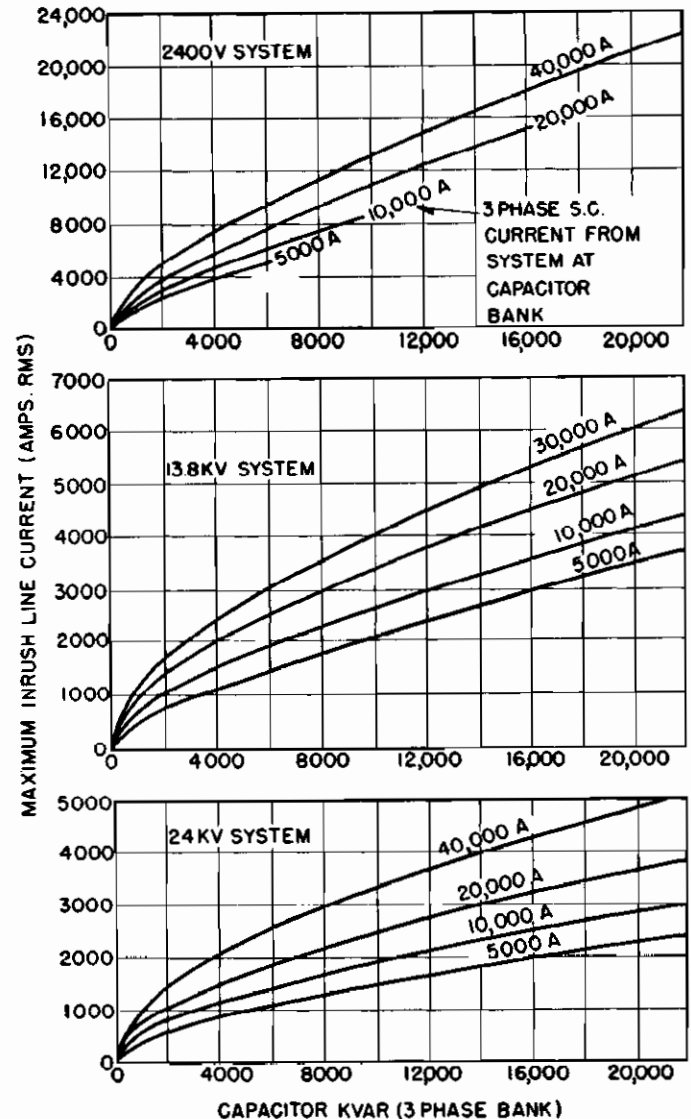

Fig. 24—Inrush current from system when energizing capacitor bank.

voltages the maximum rms inrush current for different system short-circuit currents available at the capacitor terminals. This current can be calculated using the following formula:

$$I = \frac{E_{LG}}{X_c - X_L} \left[1 + \sqrt{\frac{X_c}{X_L}} \right] \quad (12)$$

Where E_{LG} is line-to-ground operating voltage on the capacitor bank.

X_c is the capacitive reactance in ohms of one phase to neutral of the capacitor bank.

X_L is the inductive reactance in ohms per phase of the source.

The above formula applies to delta-connected capacitor banks if X_c is determined as the reactance of the equivalent line-to-neutral capacitor kvar. The current values are for the first step of a bank. If one or more steps in the capacitor bank are already energized, then the maximum peak current that flows into the next capacitor group to be energized is determined largely by the momentary discharge from those capacitor units already in service.

The breaker controlling the last step in a bank of capacitors is the one that is subjected to maximum peak current when this step is energized. The peak currents if no charge is on the step being energized, can be determined approximately by using the following equation:

$$I_{\text{peak}} = (1.2) (\sqrt{2}) \left(E_{LN} \sqrt{\frac{C}{L}} \right) \quad (13)$$

If the step being energized is fully charged, the peak inrush current can be about twice this value. E_{LN} is rms line-to-neutral voltage applied to the capacitors. C is the total capacitance per phase of the capacitors already energized combined with the capacitance of the step being energized. For a three step bank with two steps energized and with the third step being energized then

$$C = \frac{1}{\frac{1}{C_1 + C_2} + \frac{1}{C_3}} \quad (14)$$

For delta-connected banks the equivalent single-phase-to-ground capacitor kvar must be used as though the bank was wye connected. L is the inductance between the step

being energized and that portion of the bank already energized. This value of L is difficult to determine accurately, but, due to inductance in the capacitor leads and bus structure, the estimated L is usually a low value rather than a high one, thus giving a current that is too high and, therefore, on the safe side. The 1.2 factor is applied to account for some feed in from the system and also possible current unbalance due to unequal pole operation of the breaker.

The inrush current and frequency when a bank of capacitors is energized in parallel with one or more existing banks is given in Fig. 25. To illustrate its use assume a 13.8-kv, three-step capacitor installation consisting of three 2520-kvar banks, two being energized and the third step to be energized. The percent capacitive reactance for each step on 2520 kvar is 100. The two capacitor steps already energized in parallel are 50 percent on 2520 kva. These two steps in series with the one step to be energized are 150 percent. So the X_c for use with Fig. 25 is 150 percent. Now assume that each capacitor step has a series inductive reactance of 0.0076 ohm in all of its leads between the capacitor units and a common point on the bus which is 0.01 percent expressed on 2520 kvar. Two such units in parallel plus one in series gives 0.015 percent X_L for use with Fig. 25. Using this data the $X_L (X_c/100)$ equals 0.0225 which for switching in the third 2520 kvar step of capacitors allows a maximum peak inrush current of about 69 times normal rms rated current of each step or 69×105 , or 7250 amperes. The frequency of this current is about 6000 cycles. If the inductive reactance of the leads is less than 0.0076 ohm, the maximum inrush current is greater than 7250 amperes.

Where the inrush current when switching banks of capacitors is excessive, it can be limited by the insertion

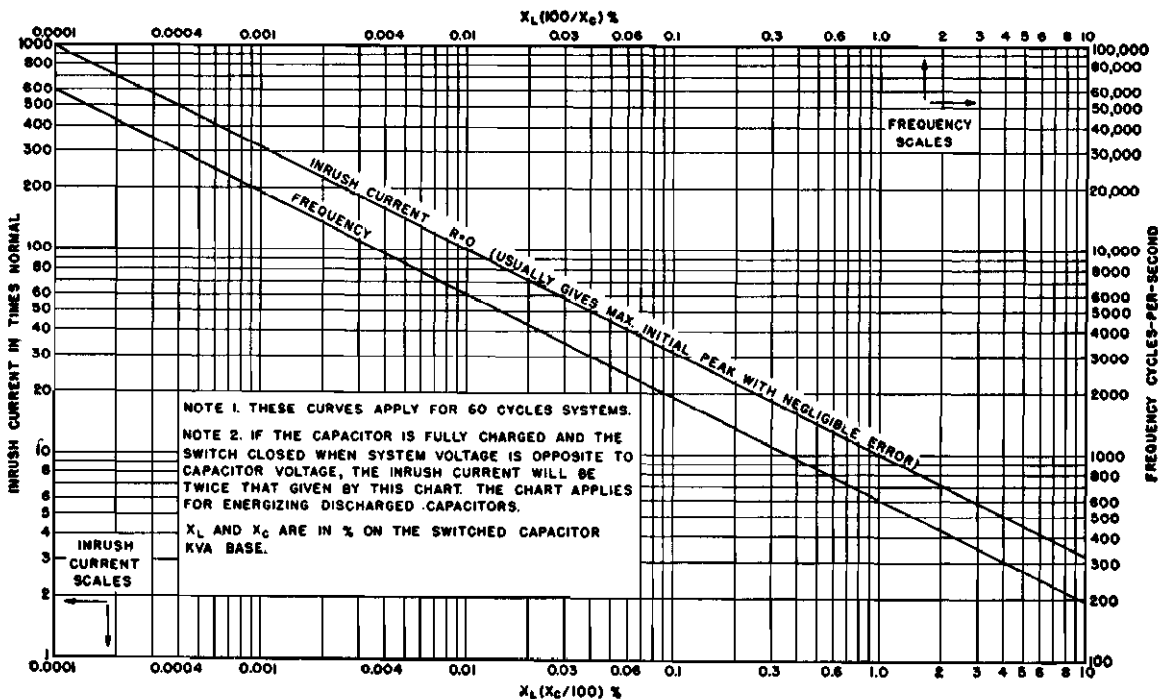

Fig. 25—Magnitude and Frequency of transient inrush current when energizing a bank in parallel with one existing bank.

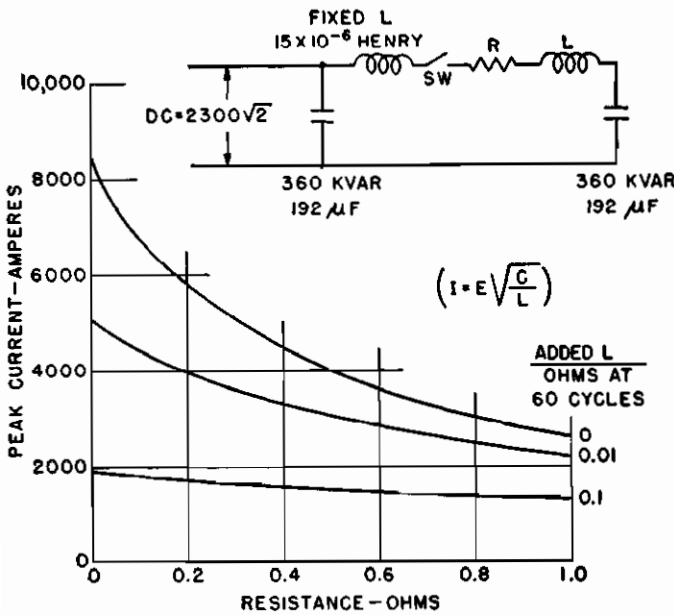

Fig. 26—Test results indicating the effect of reactance and resistance on limiting energizing inrush current.

of reactance or resistance into the circuit. Reactance is much more effective than resistance. The curves in Fig. 26 give the results of tests showing the effect of adding resistance or reactance in reducing the peak inrush current; D-c voltage was used to charge one group of capacitors; the voltage was then removed and when the switch was closed between the two groups, the peak current was measured.

21. Voltages When Switching Off Capacitors

Since the current goes out at normal current zero when de-energizing a bank of shunt capacitors, the rms voltages resulting can be calculated. The voltages to ground, recovery voltage across circuit breakers, and the line-to-line and line-to-neutral voltages across the capacitors are important. The voltages of Table 8 expressed in percent of normal peak line to neutral voltage are obtained when the supply system is grounded solidly and does not suffer neutral displacement while switching a wye-connected ungrounded capacitor bank. For a normal breaker opening, one phase is interrupted first even for a well adjusted breaker, at current zero, and 90 degrees later the other two phase currents are interrupted simultaneously at current zero by the clearing of either B or C breaker contact.

TABLE 8

Phase of Wye Connected Bank	Percent of Peak Voltage		
	A	B	C
Sequence of Opening	1st	2nd	2nd
Maximum E to Ground after Opening	150	87	87
Maximum E across Corresponding Breaker Pole	250	187	187
Maximum Voltage across Capacitor Leg Following Interruption	100	37	137

The voltages of Table 8 are brought about by the fact that 100 percent voltage is left on A phase, the first phase to open. The very instant A phase opens, a charge of 50-percent voltage is left on phases B and C because the instantaneous voltage across these two phases is 50 percent. The neutral point of the capacitor bank remains at a potential of 50 percent above ground, which appears across the capacitance to ground. The subsequent voltage applied across B and C when B or C clears is 173 percent, half of which is across B capacitor and half across C capacitor. But the 50-percent charge left on these two phases, when A opened, is still present and adds or subtracts from half of 173 percent giving a net of 37 percent or 137 percent. Similar analyses can be made for delta-connected capacitors.

The voltage across the contacts of the circuit breaker is important because if the recovery rate or the magnitude is too great, restriking occurs across the contacts. Such restriking cause switching surges that may produce peak voltages of several times the normal peak voltage to ground. Special consideration should be given to this problem in each case. The problem is more acute at voltages above 15 kv. Careful adjustment of the breaker can make an otherwise unsatisfactory condition one which is acceptable. Special treatment with respect to the oil flow in the breaker grid during interruption usually solves the problem. In extreme cases it may be necessary to limit restriking on de-energizing by inserting in series or parallel with each phase of the capacitor circuit a suitable resistor just prior to the operation of the circuit breaker to de-energize the bank. A careful analysis of the problem should be made for each application; laboratory and field tests may be necessary.

22. System Harmonic Voltages

Since the reactance of a capacitor varies inversely as the applied frequency relatively small harmonic voltages cause relatively large current-wave distortion. Capacitors are therefore built to permit combined harmonic and 60-cycle kvar to equal not more than 135 percent (AIEE Standard) of the capacitor nameplate rating. The kvar loading of a capacitor expressed as a fraction of its rating with harmonic voltages applied can be obtained as follows: $KVA = E_1^2 + 3E_3^2 + 5E_5^2 + \dots$ where all voltages are expressed as a fraction of the rated voltage. If only one harmonic is present, it can have a value of

$$E_N = \sqrt{\frac{1.35 - E_1^2}{n}} \tag{15}$$

where *n* is the order of the harmonic.

The standard margins in capacitors are usually more than sufficient for the amounts of harmonic voltages present in most systems and, therefore, very little trouble is experienced. The principal cause of harmonic currents in capacitors is the magnetizing requirements of system transformers. If the transformers are operated near their rated voltages, the harmonic voltages are limited to minimum values. Capacitors do not generate harmonic voltages.

Harmonic frequencies usually encountered are the third and fifth. The capacitor has lower reactances to higher

frequencies and therefore allows proportionately larger currents. Figure 27 shows the amount of total rms current, fundamental and one harmonic, which standard capacitors can carry, depending on how much total rms voltage, fundamental and harmonic, exists at the same time. For example, suppose the fifth harmonic and the fundamental are present and the total rms voltage is 105 percent. Then

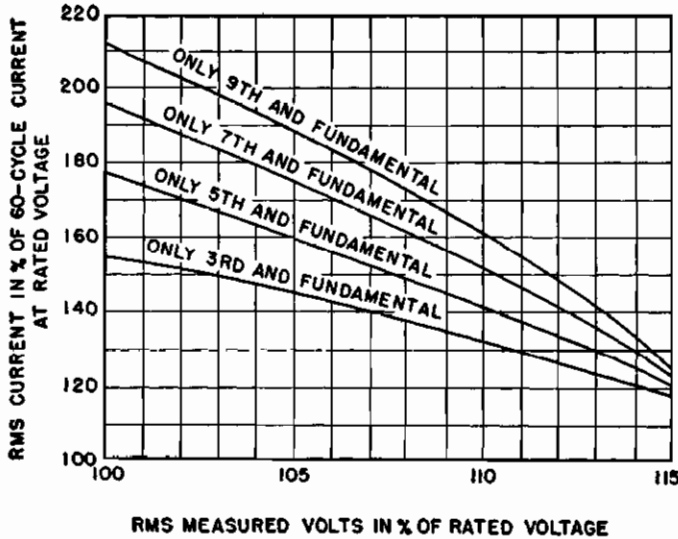

Fig. 27—Permissible harmonic currents. For 135 percent kvar for different fundamental voltages without exceeding thermal limits.

the total current the capacitor can carry is 161 percent. This is made up of about 102-percent rated amperes at fundamental frequency and about 125-percent rated amperes at fifth harmonic. The corresponding voltages are 102-percent fundamental and 25-percent fifth harmonic.

Breakers applied with shunt capacitors must have sufficient continuous current-carrying capacity to handle expected harmonic currents along with the rated-frequency current.

23. Discharge Current

When a capacitor is short circuited, either at its terminals or through a length of feeder, it discharges its stored energy determined by

$$\text{Stored energy} = \frac{1}{2} CE^2 \tag{16}$$

If the short circuit occurs at the instant the voltage on the capacitor is a maximum, then the stored energy is a maximum. The stored energy is dissipated in the resistance of the circuit which includes the capacitor and the feeder up to the short circuit. The peak current, the frequency of the current and the time constant of the circuit can be calculated for a given situation. Figure 28 shows the peak value of current calculated for various lengths of bus consisting of single-conductor cables with an equivalent delta spacing of four feet. The peak current is high in magnitude but since the frequency is high and the time constant of the circuit low, the current decreases rapidly. For all practical

sizes of capacitor banks, the discharge current reaches half value in about 0.02 second, or less. Breakers normally applied with capacitor banks are capable of handling these currents.

24. Harmonics and Coordination with Telephone Circuits

The principal cause of harmonic voltages and currents in capacitors is the magnetizing requirements of transformers. Because of the lower impedance of capacitors at higher frequencies, the harmonic currents may become so high as to endanger the life of the capacitor, or cause excessive fuse blowing, or overheating of breakers and switches. The standard margins built into capacitors, which were mentioned previously, are usually sufficient so that for the amount of harmonic voltage present in most systems no undue amount of trouble is experienced. For the transformer magnetizing current the third harmonic components and their multiples are supplied usually by circulation around the delta connected windings. The higher harmonics are usually so small that they give no appreciable trouble as long as the transformers are operated near their rated voltage.

An unbalanced fault on a system supplied by water-wheel generators without damper windings may produce harmonic voltages. By resonance or partial resonance with capacitors these voltages can be magnified. While the duration of the fault might not be sufficiently long to injure the capacitor, it may result in blowing of capacitor fuses all over the system. This hazard is reduced by properly designed damper windings and system arrangement.

Considerable study has been given the effects of shunt capacitors on the inductive coordination of power systems

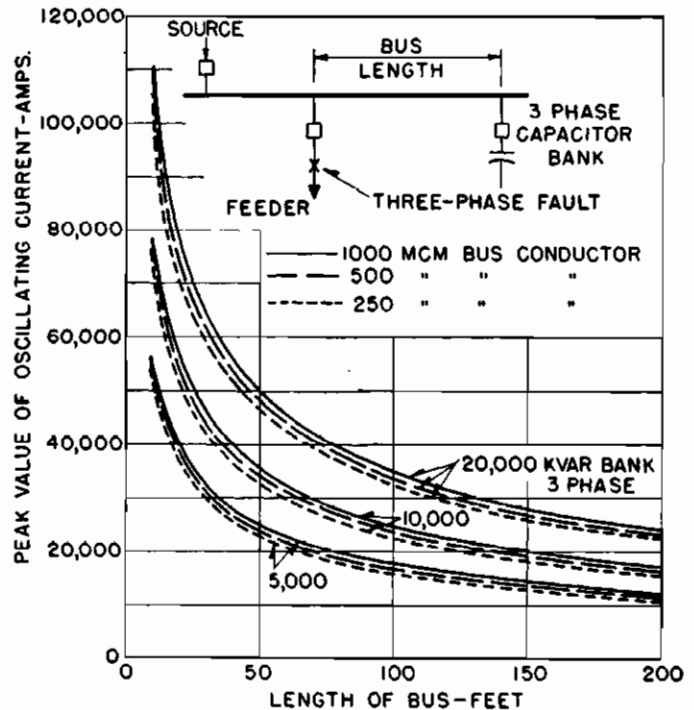

Fig. 28—Peak current supplied to a three phase fault through various lengths of bus from shunt capacitor banks.

and exposed telephone circuits at noise frequencies. These studies have been carried on by the Joint Subcommittee on Development and Research of the Edison Electric Institute and Bell Telephone System. The results of their preliminary study of the problem were included in an article published in the August, 1938 issue of the Edison Electric Institute Bulletin. It has been found that the use of capacitors may be either detrimental or beneficial from the inductive coordination standpoint, depending on the particular conditions in each case. Advance planning by the power and communication industries has reduced the number of troublesome situations to a small percentage of the capacitor installations. Where capacitors have resulted in increased noise, it has generally been practicable to improve conditions by relatively simple measures applied to either the power or communication systems or both. A summary of the available measures is included in the article mentioned above and in Chap. 23 of this book.

25. Portable Capacitors

Portable capacitor units such as shown in Fig. 29, are effective in relieving overloaded facilities until more permanent changes in the system can be made. Two single-

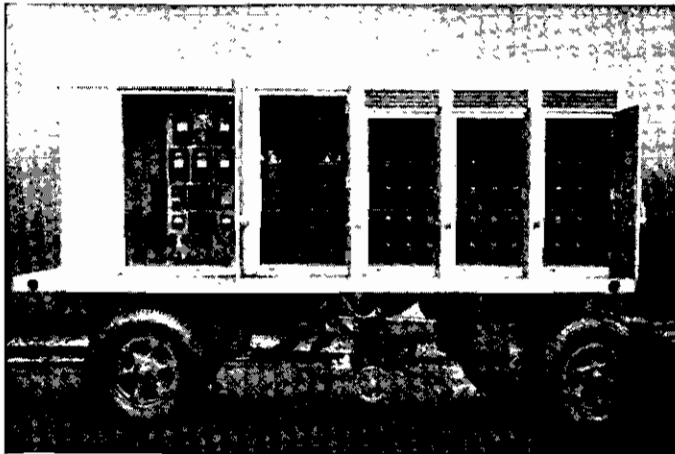

Fig. 29—Portable capacitor bank.

phase mobile capacitor units can be used to reduce the overload on open-delta banks of transformers occasioned by the failure of one transformer of a three-phase delta-connected bank. In the open-delta application the most effective use of the capacitors is to plan twice as much capacitive kvar across the phase lagging the open side of the delta as is placed across the open side.

26. Capacitors and System Stability

Shunt capacitors reduce the static stability limits of generators (and systems) because they reduce the field currents used for a given kw load and terminal voltage. The effect is noticed by an increase in generator power factor as more and more shunt capacitors are added. Actually many factors are involved in determining the static stability limits of generators, some of which are difficult to evaluate. However, the effect of shunt capacitors can be determined rather directly.

The static stability limit of a generator for a given set

of conditions is directly proportional to the voltage on the air-gap line of the generator corresponding to the excitation current. Therefore, as more shunt capacitors are added to a system, the power factor of the generators increase and consequently the exciting current decreases. As the exciting current is decreased, the voltage on the generator air-gap line decreases. The static stability limit is therefore proportional to generator exciting current. Generally on turbo-generators, if the operating power factor at full load is no greater than 95 percent lagging, experience has shown that the operation is safe. In some cases generators are operated between 95 percent lagging and 100 percent power factor with satisfactory performance. Few, if any, generators are operated consistently at power factors in the lead unless the generators are designed specifically for such service. Hydro-generators may also be affected by shunt capacitors, but usually these generators are so far removed electrically from capacitors that the generators are affected more by other factors such as the characteristics of transmission lines and the sending of power over relatively long distances.

Any generator, regardless of its prime-mover, may be affected by system shunt capacitors and therefore the problem should always be taken into consideration. This is particularly important where large amounts of shunt capacitors are planned for systems where generators are already operating at high power factors. A few power systems have this problem now and more will probably have the problem as future plans are made to get better overall system economy by taking advantage of the characteristics of shunt capacitors. This problem also has a direct bearing on how much capacitor kvar can be permanently connected through minimum-load periods with few generators in service and how much capacitor kvar can be installed with switching to provide needed kvar during maximum load periods and maximum generation.

27. Surge Protection of Shunt Capacitors

On circuits exposed to lightning it is recommended that lightning arresters be provided on all delta-connected capacitors either housed or hanger type large or small banks. Likewise arresters are recommended for all wye-connected capacitor banks where the neutral is ungrounded. Where the capacitor bank is switched, it is best practice to provide arresters on the capacitor side of the circuit breaker.

A capacitor bank connected in wye with the neutral grounded has the ability of sloping off the front and reducing the crest of traveling waves, so that it affords added lightning protection to the capacitor bank itself and to transformers and other adjacent equipment. Thus there is some question as to whether or not arresters are needed. In addition, for those surges where arresters are required there is also some hazard to the arrester because the capacitor discharges through the arrester when the arrester operates. When the capacitors are connected to a bus with transformers and other circuits, arresters are required to protect this other equipment whenever the capacitor bank is disconnected. The arresters are therefore available and in service at all times. Where the capacitor bank is the only load on a transformer winding the arresters can be omitted if the transformer is removed from service when

all capacitors are disconnected. Where the capacitors are supplied from a third winding of the transformer, arresters may be required on this winding if all of the capacitors are to be out of service at times.

From a surge-protection point of view for greatest safety to the arresters, wye-connected capacitor banks should be operated ungrounded. For best surge protection of the capacitors, the neutral should be grounded and arresters provided. There are other problems with capacitor banks, however, which make the wye-grounded bank undesirable. The grounded-neutral bank provides a path for the third or residual harmonics, thereby increasing the probability of communication interference; if a capacitor unit becomes shorted, where there is a single unit between line and neutral, the fault current can exceed the ability of the fuse to clear before the capacitor unit is ruptured.

Lightning arresters protecting high-voltage capacitor banks above 15 kv are subjected to switching surges, when the capacitors are switched, whether or not the capacitor bank neutral is grounded. With restriking across breaker contacts, which may occur, the arresters may be damaged. Therefore it is necessary to provide means of limiting the restriking in the breaker to protect the arresters. The solution in a given case may require special field tests to determine the proper adjustment of the breaker or to determine what changes are necessary.

28. Capacitors Versus Synchronous Condensers

In large units synchronous condensers constitute a competitor of shunt capacitors. The following points should be considered in comparing these two types of equipment.

1. A standard synchronous condenser is capable of supplying kvars equal to its rating to the system as well as absorbing them to an extent equal to 50 percent of its rating. For those applications requiring these characteristics, the comparison should be on a basis of the synchronous condenser against the capacitor at full kvar plus a shunt reactor of 50 percent kvar.

2. The fineness of control of the synchronous condenser cannot be duplicated by the capacitor unless a large number of switching steps are used.

3. An instantaneous drop in terminal voltage, within practical limits, increases the kvar supplied to the system in the case of a synchronous condenser whereas a similar change in the case of capacitors decreases the kvar supplied to the system. In this regard the synchronous condenser has greater stabilizing effect upon system voltages and likewise tends to maintain synchronism between machines. Its mechanical inertia, in general, has a further stabilizing effect upon the other synchronous machines comprising the system. By reason of these same characteristics, a synchronous condenser reduces the effects of sudden load changes or rapidly varying loads, such as drop in system voltage occasioned by starting of a large motor or operation of large welders.

4. For short periods the synchronous condenser can supply kvar in excess of its rating at normal voltage, whereas this is not the case for capacitors.

5. The losses of synchronous condensers are much greater than those of capacitors. For synchronous condensers the full load losses vary from about 3 percent of

the kva rating for 3000 kva units to about 1½ percent for very large units of 50 000 to 100 000 kva. For capacitors the losses are about one-third of one percent of the kva rating. The no-load losses of air-cooled synchronous condensers are about 60 percent of the full-load losses and for hydrogen-cooled synchronous condensers about 40 percent; therefore, at fractional loads the losses of the synchronous condenser are not in proportion to the output in kva. For a capacitor, however, the losses are proportional to the kvar connected to the system.

6. A comparison of the cost of synchronous condensers and capacitors involves an evaluation of the losses. Figure 30 gives an idea of the relative cost of air-cooled outdoor

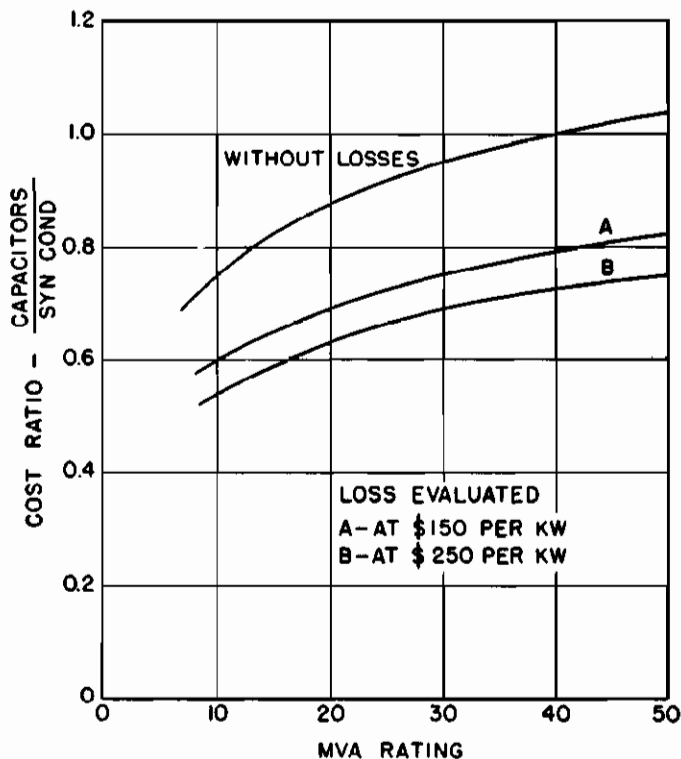

Fig. 30—Approximate relative cost of shunt capacitors and synchronous condensers. (Capacitors connected in wye and switched in five steps. Costs do not include main circuit breaker, land space, foundations, or space parts, but do include freight, automatic control, erection, capacitor fuses, coolers on synchronous condensers, and so forth.)

synchronous condensers and capacitors. Three evaluations for losses were assumed 0, \$150, and \$250 per kw. The low losses of the capacitors should not be evaluated as highly as those for the synchronous condenser because, as just mentioned, at fractional loads the losses decrease more rapidly than for the synchronous condenser.

7. Capacitors lend themselves to distribution at several locations throughout the system, which is difficult to do economically with small synchronous condensers. Thus, capacitors can be located at points closer to the load and be more effective.

8. The kvar rating of a capacitor installation can be increased or decreased as the loads and system requirements dictate, which is impractical with synchronous condensers. Capacitors can be installed easily. By moving

capacitors from point to point as required, the installation of other equipment such as transformers, may be deferred. Foundations are less important than for synchronous condensers, and auxiliaries are fewer and simple.

9. A failure of a single fused unit in a bank of capacitors affects only that unit and does not jeopardize operation of the entire bank. A failure in a condenser removes the entire ability to produce kva. On the other hand, failure of a synchronous condenser is less likely to occur than failure of a single unit in a bank of capacitors.

10. Synchronous condensers add to the short-circuit current of a system and may increase the size of breakers required. This is rarely, if ever, the case with shunt capacitors. On the other hand, breakers used in the switching large banks of capacitors may involve large currents of short duration. In general, however, these currents fall within circuit-breaker ratings dictated by the power system.

29. Capacitors and Synchronous Condensers

Banks of shunt capacitors have been used in conjunction with synchronous condenser where fluctuating loads of low power factor are prevalent or where the steps in the capacitor bank were too coarse to give the desired fineness of voltage control. In this way the economy of using shunt capacitors for part of the kvar correction can be had by using one or several steps of capacitors with breakers. Where the voltage of the bus is controlled by the combination of capacitors and condenser, the master control would be from the bus voltage. It is more likely though that the bus voltage will be controlled by other means such as a tap-changing-under-load supply transformer, and that the object of using the kvar corrective equipment is for power-factor regulation. In such cases the control of the kvar must be accomplished by a power-factor regulator.

V. SERIES CAPACITORS FUNDAMENTALS

Like the shunt capacitor, the series unit has application on transmission and distribution lines. Behavior of the shunt capacitor is generally well understood and can be accurately predicted. The same is not always true of the series type. Many questions are still unanswered and many problems are still unsolved. However, developments and experience of recent years are bringing new knowledge and maturity to the science of applying series capacitors to improve conditions on distribution and transmission lines.

Constructionwise, shunt and series capacitors are identical. In fact, should the need for a series capacitor disappear, the capacitor units can be removed and reinstalled as shunt units. The two types differ in their method of connection. The shunt unit is connected in parallel across full line voltage. The series unit is connected in series in the circuit and hence conducts full line current. While the voltage on a shunt installation remains substantially constant, the drop across the series bank changes instantaneously with load, as with any series device. It is this characteristic, which produces an effect dependent on load, that makes the series capacitor extremely valuable in certain applications by compensating for line series inductive reactance.

A series capacitor in an a-c circuit introduces negative or leading reactance. Current through this negative reactance causes a voltage drop that leads the current by 90 degrees. This drop is opposite from that across an inductive reactance. Thus a series capacitor at rated frequency compensates for the drop, or part of the drop, through the inductive reactance of a feeder. The effects of this compensation are valuable in two classes of applications: one, on radial feeders to reduce voltage drop and light flicker; and, two, on tie feeders to increase the ability of the feeder to transfer power and help the stability of the system.

30. Effects on Radial Feeders

The action of a series capacitor to reduce voltage drop is illustrated in Fig. 31. The voltage drop through a feeder is approximately

$$IR \cos \theta + IX_L \sin \theta \quad (17)$$

where R is feeder resistance, X_L feeder reactance, and θ the power-factor angle. If the second term is equal to or

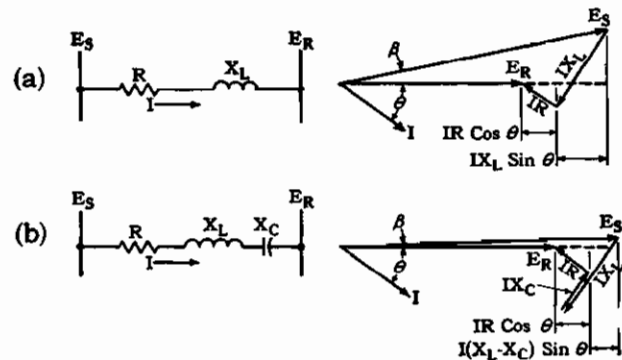

Fig. 31—Voltage vector diagrams for a circuit of lagging power factor (a) without and (b) with series capacitors. The series capacitor increases the receiving-end voltage, thus reducing voltage drop.

greater than the voltage improvement desired, a series capacitor may be applicable. The magnitude of the second term is a relatively larger part of the total voltage drop where power factor is low and where the ratio of feeder resistance to reactance is small. With a series capacitor inserted, Fig. 31(b), the voltage drop becomes

$$IR \cos \theta + I(X_L - X_C) \sin \theta \quad (18)$$

or simply $IR \cos \theta$ when X_C equals X_L . In most applications the capacitive reactance is made smaller than feeder reactance. Should the reverse be true, a condition of overcompensation exists. Overcompensation has been employed where feeder resistance is relatively high to make $I(X_L - X_C) \cos \theta$ negative. However, overcompensation may not be a satisfactory condition if the amount of capacitance is selected for normal load, because during the starting of a large motor the lagging current may cause an excessive voltage rise, as shown by Fig. 32. This is harmful to lights and introduces light flicker.

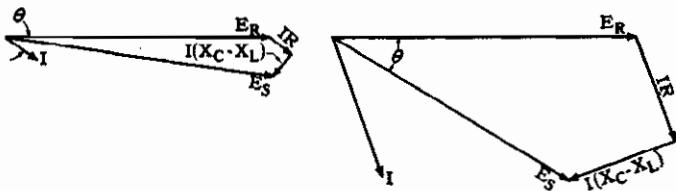

Fig. 32—The high lagging current due to motor starting rapidly raises the receiving-end voltage of a circuit which is over-compensated with series capacitors.

The power factor of the load current through a circuit must be lagging for a series capacitor to decrease the voltage drop appreciably between the sending and receiving ends. If power factor is leading, the receiving-end voltage is decreased by the addition of a series capacitor, as indi-



Fig. 33—When the load power factor is leading, a series capacitor is undesirable because it decreases the receiving end voltage.

cated by Fig. 33. If the power factor is near unity, $\sin \theta$ and consequently the second term of Eq. (18) are near zero. In such cases, series capacitors have comparatively little value.

When properly applied, a series capacitor reduces the impedance of a line and thereby raises the delivered voltage. This increases the kva capacity of a radial feeder and, for the same delivered load kva, slightly reduces line current. A series capacitor, however, is not a substitute for line copper.

31. Light Flicker

Series capacitors are suited particularly to radial circuits where light flicker is encountered due to rapid and repetitive load fluctuations, such as frequent motor starting, varying motor loads, electric welders, and electric furnaces. A transient voltage drop, which causes light flicker, is reduced almost instantaneously in the same manner as voltage drop due to a slowly increased load. To predict accurately the reduction in voltage flicker by series capacitors, the current and power factor of the sudden load increment must be known. It is obvious that to improve voltage conditions or reduce light flicker at a given load point the series capacitors must be on the source side of that point. The series capacitors must compensate for line inductance between the source and the point where it is desired to reduce light flicker. This sometimes makes the application of capacitors difficult because one feeder from a bus with several feeders may have a fluctuating load that produces sufficient voltage change on the bus to cause light flicker on all feeders. To use series capacitors to reduce the flicker, they must be installed in the supply circuit or circuits to the bus.

Shunt capacitors cannot be switched fast enough to prevent light flicker. In fact, an attempt to use shunt capacitors for this purpose might aggravate the situation.

Step voltage or induction voltage regulators, also, are not sufficiently rapid to follow sudden voltage fluctuations. The voltage dip cannot be prevented by shunt capacitors or regulators as the dip itself is used to initiate the correction.

32. Effects on Tie Feeders

Series capacitors can be applied to tie feeders to increase power-transfer ability and improve system stability rather than to improve voltage regulation as on radial feeders. The vector diagrams and Eq. (17) and Eq. (18) still apply but the emphasis is now on power transfer and stability. For simplicity, assume the feeder impedance consists only of inductive reactance. Since the effect of resistance is small in most tie-feeder circuits, it can be neglected without materially affecting the results. Referring to Fig. 34,

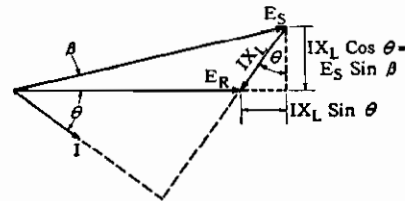

Fig. 34—Vector diagram for a tie feeder in which resistance effects are neglected.

the simplified equation for the amount of power transferred through a tie feeder is:

$$P = E_R \frac{E_S \sin \beta}{X_L \cos \theta} (\cos \theta) = \frac{E_R E_S \sin \beta}{X_L} \quad (19)$$

where β is the angle between the sending (E_S) and receiving (E_R) voltages. With a series capacitor, the expression for power transfer is

$$P = \frac{E_S E_R}{X_L - X_C} \sin \beta \quad (20)$$

Therefore, for a given phase-angle difference between the voltages, the power transfer is greater with a series capacitor. Thus by making possible a greater interchange of power, the normal load transfer and the synchronizing power flowing during transient conditions are increased, thereby helping stability. This is illustrated in Fig. 35,

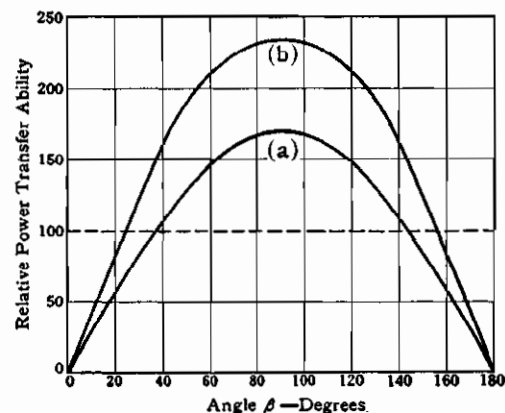

Fig. 35—The power-transfer ability of a tie feeder may be increased from curve (a) without series capacitors, to curve (b) with series capacitors.

which shows that for the same angle, a series capacitor effects a 40-percent increase in power-transfer ability—and also the maximum power that can be transferred. Furthermore, to transfer the same amount of power through the tie feeder, angle β is smaller, which aids stability of the system.

A series capacitor on a radial feeder is ineffectual unless the load power factor is lagging. This is not as important in most tie feeders as can be seen from Eqs. (19) and (20). Power transfer is affected primarily by the angle between the sending and receiving voltages and not as much by power factor.

33. System Power Factor Improved

The lagging kilovars supplied by a series capacitor improve system power factor, just as a shunt capacitor or an overexcited synchronous machine, but to a much smaller extent. In effect, the capacitor compensates for the I^2X_L "lost" in the feeder reactance. The amount of compensation varies, of course, as the square of the current since the kilovars supplied equal I^2X_C . At half load, for example, only one-quarter rated kilovars is provided.

34. Relative Effect of Power-Factor Correction

A shunt capacitor improves load voltage by neutralizing part of the lagging current in a circuit, thereby reducing the line current and voltage drop. A series capacitor improves load voltage more effectively by compensating directly for part of the feeder reactance, which causes the voltage drop. Consequently, the same voltage correction is obtained with a smaller rating of series capacitors than shunt, usually in the ratio of one half to one fourth. However, because the amount of power-factor correction increases with capacitor kvar rating, the shunt capacitor corrects power factor to a greater extent.

For example, on a 10 000-kva circuit having a load power factor of 80 percent and an R/X ratio of 0.3, 1100 kilovars of series capacitors are required to limit the voltage drop to 10 percent. This capacitor raises the source power factor from about 74 to about 78 percent. If a shunt capacitor is used in this circuit to obtain the same voltage correction, 3800 kilovars are required, but the source power factor is raised from 74 percent to 91 percent lagging.

To increase materially the source power factor as well as improve voltage, shunt capacitors at or near the load offer the best solution. Usually shunt capacitors must be switched in one or more groups to keep within desired voltage limits as load varies. Shunt capacitors do not reduce light flicker because they cannot be switched on and off fast enough to counteract rapid fluctuations in voltage.

VI. APPLICATION OF SERIES CAPACITORS

In general, series capacitors are applicable to radial circuits supplying loads of about 70 to 95 percent lagging power factor. Below 70 percent, shunt capacitors are more advantageous (unless the power factor changes over such a wide range, making it impossible to switch shunt capacitors fast enough to supply the kvar required by the load). Above 95 percent, the small value of $\sin \theta$ limits

the beneficial effect of series capacitors. Applications to radial circuits supplying loads of 70 to 90 percent power factor are most likely to be successful.

The application of series capacitors differs materially from that of shunt capacitors. Where voltage correction is the primary function of shunt capacitors the correction is obtained by raising the power factor of the load. To determine the shunt capacitor kvar required, the most important data needed are the magnitude of the load, its power factor and the impedance of the source circuit. While similar data are required for voltage correction with series capacitors, the effect of series capacitors is to reduce the reactance of the source circuit. Series capacitors affect power factor to a limited extent as compared with shunt capacitors because usually the kvar in a series capacitor is much smaller, being one-fourth to one-half of the shunt capacitor kvar for the same change in load voltage. In addition, the series capacitor contributes its kvar to the system as the square of the load current.

35. Determination of Capacitor Rating

A three-phase circuit containing a series capacitor consists of line resistance, line inductive reactance, and capacitive reactance. The kva ratings of these components are $3I^2R$, $3I^2X_L$, and $3I^2X_C$. These values as a percent of the total circuit rating are useful in considering the usefulness of series capacitors. The percent rating is obtained by dividing the kva rating of each element times 100 by the total circuit kva rating ($\sqrt{3}E_R I$) which must be known. The percent rating of the capacitor equals $300 IX_C/\sqrt{3}E_R$ (or $173 IX_C/E_R$) where I is full-load rating of the circuit and E_R is the load line-to-line voltage.

Calculation of kva ratings as a percent of circuit rating can be extended to voltage. The voltage drops, IR , IX_L , and IX_C times 100, are divided by the circuit voltage rating $E_R/\sqrt{3}$. The percent of the capacitor again equals $173 IX_C/E_R$. Consequently, the percent ratings of each component on a kva base and on a voltage base are identical. Therefore, a series capacitor rated 20 percent on the base of circuit kva is also rated 20 percent on the base of circuit voltage. These ratings mean that at full load, the capacitor "consumes" 20 percent of rated circuit kva and the voltage drop across its terminals is 20 percent of rated circuit voltage.

The rating of a series capacitor (kilovars, voltage, and current) for a radial feeder depends on the desired voltage regulation, the load power factor, and the amount of resistance and reactance in the feeder relative to each other and to the circuit rating. The capacitor kilovar rating can be determined for 80 or 90 percent load power factor and 5 or 10 percent circuit voltage drop from data given in the curves of Fig. 36. To use these data, the feeder rating is taken as 100 percent kva and all other figures are calculated in percent on this base. For example, assume a 10 000-kva feeder having an inductive reactance of 20 percent and a ratio of resistance to reactance of 0.3 supplying a load whose power factor is 80 percent. From Fig. 36, to limit the voltage drop to 5 percent at full load, the series capacitor must be rated 20 percent of the circuit rating. This is 20 percent of 10 000 kva or 2000 kilovars. The capacitor voltage rating is also 20 percent of the rated circuit voltage.

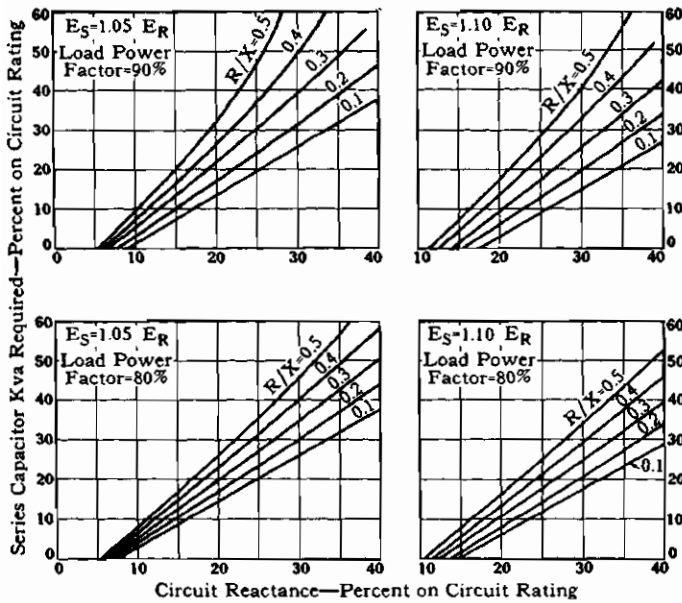

Fig. 36—Kilovar and voltage ratings of a series capacitor for a radial feeder may be determined for many cases from these curves.

Thus if the circuit is rated 20 000 volts, phase to neutral, the capacitor is rated 4000 volts. If a voltage regulation of 10 percent is permissible, only 1100 kilovars (at 2200 volts) are required. Had load power factor been 90 percent, 2200 kilovars (at 4400 volts) would be necessary for 5-percent regulation and 900 kilovars (at 1800 volts) for 10-percent regulation.

Other factors being equal, the ratio of R/X_L has a large effect on capacitor rating, as Fig. 36 indicates. Higher ratios require more capacitors; this is seen vectorially in Fig. 37.

The current rating of the capacitor equals that of the circuit because the bank must be able to carry rated circuit

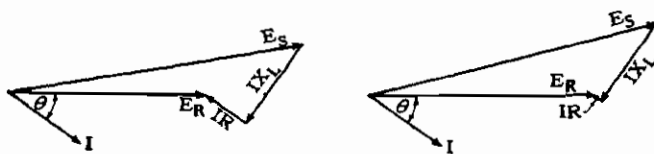

Fig. 37—Radial feeders having a higher ratio of resistance to reactance (for the same percent reactance) necessitate more capacitors.

current continuously. In addition, when circuits supply relatively large motors, the capacitor must be able to carry temporarily the starting current of the largest motor plus the current of other loads already in service. The total of the transient and steady-state currents through the capacitors should not exceed 1.5 times rated.

The rating of a series capacitor applied to a tie feeder is determined from a study of the power-transfer and stability requirements. No definite rules can be stated, but in general, the capacitive reactance of a series capacitor is less than (probably not more than 70 percent) the inductive reactance of the tie line. If the maximum transient current during a system disturbance is greater than about 1.5 times rated current, stability requirements

rather than load transfer may dictate the capacitor rating for a tie-feeder application.

36. Arrangement of Capacitor Units

When the kilovar, voltage, and current ratings of the bank are known, capacitor units are arranged in series-parallel connections to obtain the desired values. Series connection builds up the voltage rating and parallel connections the current rating. Each bank must be "tailored" to fulfill the requirements of that specific application.

Capacitor banks can be assembled for any current rating and for almost any voltage rating, standard or non-standard. If the voltage across the bank is less than 230 volts, it may be economical to install a series step-up transformer to permit using standard capacitor units of higher voltage and lower cost.

37. Location of Capacitors

In general, a series capacitor can be located at any convenient place on a feeder provided that certain requirements are met. First, the voltage level at the output terminals of the bank must not be too high for the line insulation and lightning arresters; and second, a capacitor on a radial feeder must be located between the source and the load whose voltage is to be improved. Where a radial circuit has a number of tapped loads distributed throughout its length, the best location of the series capacitor is at about one third of the electrical impedance of the feeder from the source bus. If a feeder is long, two banks of capacitors may be preferable as more uniform voltage is obtained throughout the circuit. Where short-circuit current is high, it may be advisable to locate the capacitor so that fault current through the protective gaps and switches is a minimum.

A series capacitor located in a substation can be connected in each phase on the neutral ends of wye-connected transformer windings to permit use of a lower voltage class in the capacitor insulation. However, this practice raises the voltage-to-ground level of the transformer windings. This must be checked carefully. The effectiveness of a series capacitor is independent of whether it is connected on the neutral ends or on the line ends of the transformer windings.

VII. PROTECTION OF SERIES CAPACITORS

38. Protection During Line Fault

For most circuits in which series capacitors are applied, the currents and corresponding capacitor voltages during fault conditions are several times the maximum working value. As standard capacitor units can withstand about 200 percent of their rated working voltage for brief periods without damage to the dielectric, it is necessary to use capacitors with continuous current ratings equal to 50 percent of the maximum current that may flow during a fault, or to use a voltage-limiting device. For a given reactance, the cost of capacitors increases approximately as the square of the rated current so that it is more economical to use capacitors whose ratings are based on the working current and to limit the voltage that can appear across their terminals by means of auxiliary apparatus.

Care must be used that the voltage rating of the series capacitor and its associated protective equipment is made high enough so the capacitor is not by-passed during working loads. On radial circuits to insure availability of the series capacitor during motor starting currents, when its effects are most useful, the capacitor rating must be at least 67 percent of the greatest motor inrush current that may be imposed on the line plus other operating load. With protective devices set to by-pass the capacitor at 200-percent rating, the capacitor remains in service during such transient loads.

The device used to protect a series capacitor during a fault should limit the voltage rise to about twice the rated value even for a short time. The capacitor must therefore be by-passed during the first half cycle of fault current. A properly designed gap (shown in Fig. 38) fulfills this

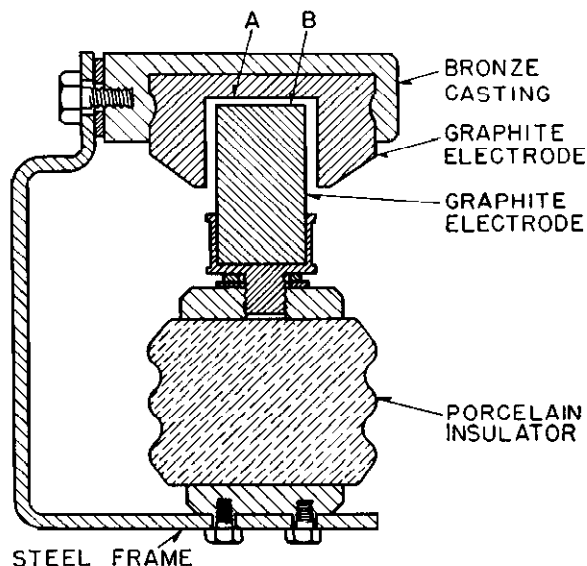

Fig. 38—Special gap for parallel protection of series capacitors.

requirement and materials can be selected to give a stable arc and a low arc drop without repetitive restriking. Under most conditions, some means must be provided for shunting this gap and transferring the arc current to another path. After the circuit current again falls to normal, the by-pass equipment must open to transfer current back through the capacitor. This commonly is done with a thermal or magnetic contactor or by an automatic circuit breaker that closes to by-pass the gap and capacitor and opens some time after the fault has cleared to restore the capacitor to service. If the installation consists of two or more groups of capacitor units in series within a bank, each can be protected by its own parallel gap.

Where the insulation class of the series capacitor is low, for example, where 230-volt capacitor units are used and the gap must break down at 460 volts, it is not possible to set the gap for sufficiently low breakdown voltage. In such instances, a trigger circuit is used to initiate the break-down of the gap.

On large series capacitors in transmission tie lines special gaps or special high-speed circuit breakers or both may be required to protect the capacitors and re-insert them into the circuit within a half cycle or a cycle after the fault is

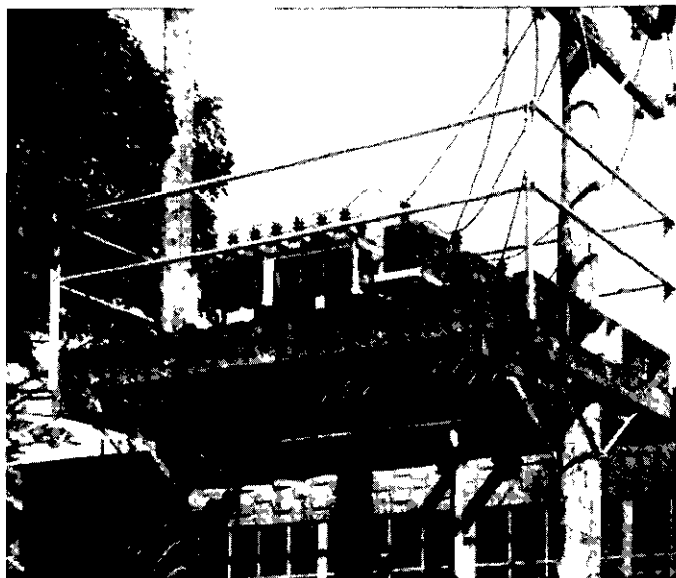

Fig. 39—A typical series capacitor on a distribution circuit.

cleared. This is necessary to enable the series capacitors to provide system stability. If the capacitors are not re-inserted within a cycle or less, their full benefit cannot be realized and their usefulness on tie lines would be reduced materially both electrically and economically.

39. Protection Against Continuous Overload

Standard series capacitors should not be used for continuous operation at an average more than 105 percent of their rated voltage. Consequently, average working current through a series capacitor should not exceed the rated working current by more than five percent. The short-circuit protective device is not designed to function at less than 200 percent of the rated current; therefore, it is sometimes desirable to provide overload as well as short-circuit protection. The overload protective device should have an inverse time-current characteristic that can be coordinated with the capacitor to allow momentary overloads but not continuous ones. Series capacitors have a 30-minute rating of 1.35 times rated current and a 5-minute rating of 1.5 times rated current. A thermally operated switch can also be used for this purpose.

This special type of protection usually is not warranted except on large series capacitor banks. The absence of overload protection on small distribution installations further emphasizes the need for care in choosing the continuous current rating.

40. Dielectric Failure Protection

Dielectric failure protection rarely is used except on large banks. This also is a feature that is sacrificed on small distribution series capacitors in the interest of simplicity and low first cost.

Dielectric protection is a means of detecting a faulted capacitor unit in a series-capacitor assembly. In an unfused capacitor bank a short-circuited capacitor may sustain an internal arc, which causes gas to be generated in the unit. Continued operation causes the internal pressure to reach a value that rupture the case and possibly damage

other units and equipment. If the units are equipped with individual fuses—and they should be—a fuse operation to remove a faulted unit increases the reactance of the bank and operation at the rated current of the original bank subjects the remaining units to overvoltage. Protection is afforded by detecting with proper relaying when the currents become unequal in two equal branches of the capacitor. When the unbalance in current exceeds the selected value, the capacitor is by-passed until the defective unit is replaced.

41. Circuit Relaying

On radial circuits, fault-protection relaying usually is not affected by the addition of series capacitors. Fault currents practically always considerably exceed twice rated current. Consequently the parallel gap breaks down on the first half cycle of fault current. This happens faster than most types of relays operate and thus relay and circuit-breaker operations are the same as without capacitors. Relaying of line-to-ground faults is accomplished usually by residual or neutral current, which is not affected greatly by a series capacitor. Fault-protective relaying on a tie feeder, however, may be affected considerably by the installation of a series capacitor. Detailed studies must be made for each case prior to installation of the capacitor.

VIII. OPERATING PROBLEMS

Along with the desirable characteristics of series capacitors, there is the possibility of undesirable phenomena, usually involving some kind of resonance, which until recently has deterred the installation of large banks of series capacitors even where they otherwise could solve difficult system problems. In many cases the difficulties can be anticipated and suitable precautions taken to make an installation practical.

Three major phenomena may be encountered in a circuit employing a series capacitor: sub-synchronous resonance of a motor during starting, ferro-resonance of a transformer, and hunting of a motor during steady-state operation. One, two, or all of these may occur.

42. Sub-synchronous Resonance During Motor Starting

When an induction or a synchronous motor is started, (the latter as an induction motor) through a series capacitor, the rotor may lock in and continue to rotate at a speed below normal or synchronous. This condition is known as sub-synchronous resonance. It is caused by the capacitor, whose capacitive reactance in conjunction with the inductive reactance of the circuit and motor establishes a circuit resonant at a frequency below that of the power supply. The rotor, in effect, acts as a stable asynchronous generator. It receives power at rated frequency from the stator windings and transposes it to the sub-synchronous frequency, which it returns to the circuit containing the capacitor. This circuit, being resonant, imposes a minimum of impedance to the sub-synchronous voltage and consequently conducts a large current. A motor operating under these conditions may be damaged by excessive vibration or heating.

The sub-synchronous frequency is dependent on the relative sizes of the motor and the capacitor. The capacitor rating is determined by the circuit rating (other conditions remaining the same, the ratings are proportional). Consequently, the resonant frequency is related, indirectly, to the rating of the motor in proportion to that of the feeder. This frequency is usually 20 to 30 cycles for a 60-cycle motor whose rating equals half the circuit rating.

As the motor size decreases with respect to the capacitor and circuit ratings, its reactance increases. During resonance, capacitive and inductive reactance are equal. Because capacitive reactance increases with decreasing frequency, the sub-synchronous resonant frequency is lower when the motor requires a smaller proportion of the circuit rating. A motor requiring less than five percent of the circuit rating can be resonant at a sub-synchronous frequency of five cycles or less if it starts under load.

The most common method of preventing sub-synchronous resonance is to damp out this frequency by placing a resistor in parallel with the capacitor. While the resistance to use can be calculated, the results thus obtained are usually one half to one tenth the values that experience proves necessary. Calculations are inaccurate because of the difficulty of giving precise consideration to such variables as inertia of the motor and load, starting load, speed of acceleration, the type of starter, and other load on the circuit. For example, load elsewhere on the circuit, when a motor is started, reduces the possibility of sub-synchronous resonance by providing a damping effect similar to that of parallel resistance.

The resistance should be as high as possible in order to hold to a minimum its continuous losses, which are equal to the square of the voltage across the capacitor bank divided by the resistance. It is common practice, then, to apply resistors that are adjustable over a predetermined range, particularly in the larger installations.

When low ohmic resistance is used, the resistor can be disconnected after the motor reaches full speed and the risk of resonance has passed. Switching could be accomplished manually or by remote control over a pilot wire or power-line carrier channel with electrically-operated switching equipment.

Sub-synchronous resonance can also be avoided by use of parallel resistors across only two phases of a three-phase series capacitor. Such a solution is permissible where the omission of resistors from one phase does not unbalance the voltage appreciably. The amount of unbalance is determined by the resistance. The higher the resistance, the less the unbalance. But the resistance necessary, not the degree of unbalance, determines the ohmic value. At least one such installation is in service and is operating satisfactorily.

Sub-synchronous resonance can exist only during motor starting. Hence, resonance can be prevented by inserting resistance in series in the supply leads to the motor instead of in parallel with the capacitor. A contactor is required to short circuit the series resistance after the motor reaches full speed. If the circuit contains only a few motors such a scheme may be more economical than a single large resistance in parallel across the capacitors. To be effective, the series resistance must be in the stator circuit of the motor.

Resistance in the rotor circuit of a slip-ring motor does not give the desired damping but affects primarily the amount of slip between the sub-synchronous frequency and the frequency of the current through the rotor circuit.

If motors are started infrequently, sub-synchronous resonance can be avoided without using resistance by short circuiting the capacitor during starting. If a temporary unbalance is tolerable, the same result can be achieved in some cases by short circuiting only one phase of the bank, which simplifies the switching equipment.

The reactance of a capacitor is inversely proportional to frequency, while that of an inductor is directly proportional. Hence, in a series circuit consisting of capacitance and inductance the voltage drop across the former increases as frequency is reduced. Therefore, a condition of sub-synchronous resonance in a power circuit causes an increase in the voltage drop across the capacitor. This voltage may be large enough to cause the protective gap in parallel with the capacitor bank to flash over, thus short circuiting the capacitor. This halts the resonant condition and permits the motor to accelerate normally to full speed. After a time delay the capacitor is automatically restored to the circuit. This sequence of operations may make it possible in some installations (particularly where motors are started rarely) to use the gap alone to prevent sub-synchronous resonance and perhaps eliminate the need for parallel resistors. However, heavy-duty gaps in series with resistors to dissipate the energy stored in the capacitors may be required.

The gap is set to break down at twice rated current (twice rated voltage) at rated frequency. Consequently, during sub-synchronous resonance at half rated frequency the gap flashes over at rated current since the capacitive reactance is doubled. The lower the frequency the smaller the current required to break down the gap.

In general, the possibility of sub-synchronous resonance should be checked for all circuits in which the largest motor requires more than five percent of the circuit rating. Experience indicates that standard motors rated less than ten percent of circuit rating encounter no difficulty if started at no load. In fact, motors rated up to 20 percent usually accelerate satisfactorily if started at no load and across the line. However, when high-inertia loads are involved, the circuit must be checked for sub-synchronous resonance even if the power requirement of the largest motor is as low as five percent of the circuit rating.

43. Ferro-Resonance in Transformers

A transformer bank when energized draws a high transient exciting current. If a series capacitor is in the circuit, it may create a resonant condition that causes the high current to continue. This is known as ferro-resonance.

Ferro-resonance is cured automatically in most cases by the parallel gap. The magnetizing inrush current is probably of sufficient magnitude and low enough in frequency to cause a voltage drop to appear across the capacitor (and across the gap) high enough to break down the gap. As the transient period approaches its end, the current in the gap decreases. The steady-state current through the gap for a short period is usually too small to maintain the arc and therefore the gap clears, restoring the capacitor to the

circuit. The possibility that the gap alone can prevent ferro-resonance is checked by oscillographic tests after the capacitor is installed.

If tests indicate that the gap is inadequate, ferro-resonance can be eliminated by shunting the capacitor with a resistor or by having a certain minimum load on the transformer side of the capacitor when the bank is energized. Of course, a parallel resistor applied to prevent sub-synchronous resonance of motors also prevents ferro-resonance of transformers.

In some cases, such as 2400- or 4160-volt circuits, the voltage rating of a series bank would be very low (and its cost high) if installed directly in the line. To permit application of a capacitor having a higher voltage rating, a transformer in series with the line is sometimes employed to step the voltage up from the required drop in the line to the capacitor rating. Such transformers must be designed carefully to prevent ferro-resonance.

A series capacitor, when installed in a long circuit supplying a transformer of abnormally high steady-state exciting current, may resonate during normal operation at a frequency corresponding to a harmonic component of the exciting current. Fluctuating loads may cause such resonance even though it does not appear when the transformer is energized. Resonance in this case is eliminated by a parallel resistor, by changing the transformer winding, or by replacing the transformer with another having a normal exciting current.

44. Hunting of Motors During Normal Operation

Hunting of a lightly-loaded synchronous motor can be caused by disturbances such as switching of power circuits and changes in load or excitation of the motor itself. Such hunting cannot be directly attributed to resonance. The principal factor in predicting hunting is the ratio of feeder resistance to total feeder reactance (including the series capacitor) between the power source and the motor terminals. If the ratio is less than one and is not negative, hunting is unlikely. Violent hunting of a synchronous motor was encountered upon application of a series capacitor in one instance because the ratio of feeder resistance to reactance was approximately four.

A synchronous motor, when fed through a long line excessively compensated by a series capacitor, may hunt if started during periods of light load. Such hunting is avoided if the power-factor angle of the load (after the motor is started) is equal to or greater than the impedance angle of the circuit (including the capacitor). The tangent of this impedance angle is the ratio of total circuit reactance (feeder reactance minus capacitor reactance) to feeder resistance.

Hunting is not limited to synchronous motors. Series capacitors should not be applied to circuits supplying either synchronous or induction motors driving reciprocating loads such as pumps or compressors. In addition to problems of sub-synchronous resonance, the motors once started may hunt, causing objectionable light flicker. The frequency of hunting is sometimes equal to, or a direct multiple of, the frequency of power pulsation, which further aggravates the situation. A cure for hunting may be the installation of a heavy flywheel to increase the

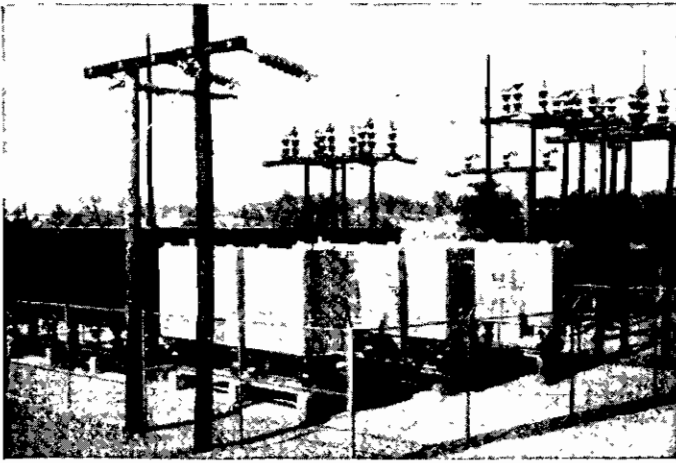

Fig. 40—10 000 Kvar series capacitor in 66-kv line showing large capacitor housings with somewhat smaller housings for parallel resistor units.

rotating mass. However, this solution may enhance the possibility of sub-synchronous resonance, which is equally undesirable.

IX. 10 000-KVAR SERIES CAPACITOR

A 10 000-kvar series capacitor is in service on a 66-kv radial circuit having a rated load of 500 amperes. Each phase of this capacitor bank consists of 240 standard 15-kvar, 2400-volt units, divided into 3 groups connected in series. Each group, which contains 80 units in parallel, is protected by its own gap and accompanying by-pass thermal switch.

This series capacitor, Fig. 40, was installed because the desired voltage improvement is obtained more efficiently and at less cost than by any other method. The principal function of the bank is to improve the voltage level and decrease flicker voltage at a steel plant where the bulk of the load consists of four 10 000-kva electric-arc furnaces. The heaviest load normally encountered is approximately 37 000-kva at about 78 percent power factor. The change in voltage conditions effected by the series capacitor is shown in Fig. 41, which indicates that the fluctuations are reduced and the average voltage level during periods of peak load is increased about 10 percent. Before installa-

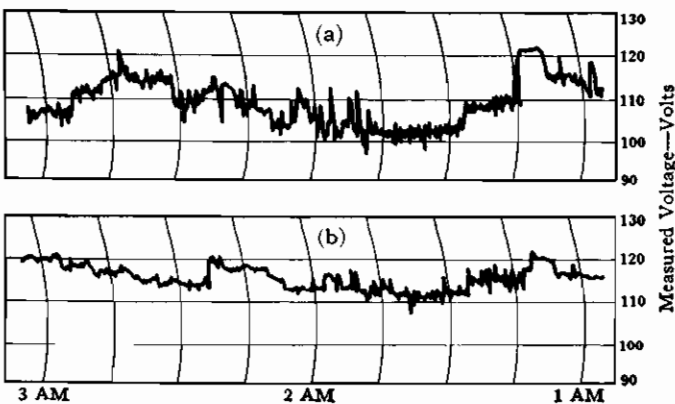

Fig. 41—Voltage conditions at the steel-mill bus (a) before and (b) after the series capacitor was installed.

tion of the capacitors, the voltage at the bus dropped from 12 000 volts at no load to 10 000 at full load. The full-load voltage is now about 11 300 volts. Furthermore, voltage conditions at the tapped point (Fig. 42), which was previously used only as an emergency supply to a nearby town, are so improved that this source now provides every-day power service.

The series capacitor compensates for 57 percent of the total circuit reactance up to the 11-kv steel-plant bus. This decreases by over 50 percent the magnitude of the change in voltage level during periods of heavy load and also

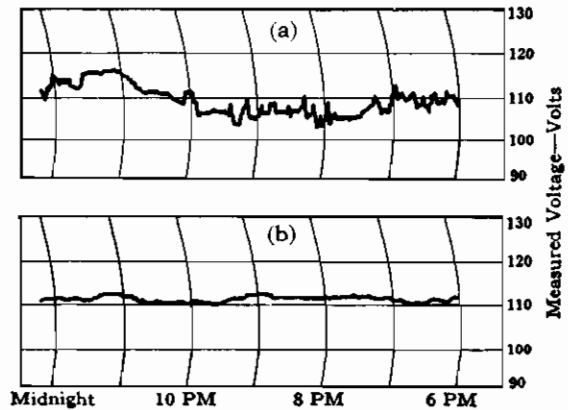

Fig. 42—Voltage conditions at tapped load point (a) before and (b) after the 10 000-kvar, 66-kv series capacitor was installed.

reduces flicker voltage. However, the capacitor compensates for 100 percent of the total reactance up to the tapped load point. As a consequence the change in voltage level is reduced even more (about 80 percent) than at the steel-mill bus. Furthermore, the sudden fluctuations at the tapped point are almost entirely eliminated.

In addition to the furnace load the steel plant has several motors, the largest being a 4000-hp wound-rotor induction motor. A 400-ohm resistor across the capacitor gives sufficient damping for successful motor starting and prevents self-excitation or sub-synchronous resonance. Such phenomena sometimes occur when large motors (relative to the circuit rating) are started through a feeder containing a series capacitor. The resistor, because of its continuous losses, is undesirable but experience has indicated that it is essential for successful motor starting.

This large series capacitor has been successful. Had a synchronous condenser been installed at the load instead of a series capacitor, the initial cost would have been at least doubled and the continuous losses would have been much greater. The installed cost of such a capacitor is estimated to be about sixteen dollars per kilovar.

X. PROGRESS OF SERIES CAPACITORS

About 100 installations of series capacitors are in service on power circuits throughout the United States. The best results are obtained where there are no relatively large motors and where the capacitive reactance provided by the series capacitor is less than the inductive reactance of the circuit up to the principal load point.

Good results have been obtained with capacitors in circuits supplying electric-arc furnaces, one of the worst types of industrial loads. Series capacitors are ideal for resistance-welding devices where they can reduce the kva demand by 50 to 75 percent. Welders can be provided with built-in capacitors. If a series capacitor is applied to an existing welder, modifications to the welding transformer must be made to prevent excessive current flow.

While most of the improper operations of series capacitors are due to the fact that circuits with series capacitance resonate at some frequency, some trouble with protective devices has been encountered. But with new developments and information and experience gained on recent applications, more reliable performance is now expected. Some types of equipment should not be supplied through series capacitors because of difficulties that at present cannot be overcome. Overcompensation except in very special cases should be avoided as it produces undesirable results.

Twenty years ago shunt capacitors were used to a very limited extent. Today they have been universally accepted as practical, reliable, and economical solutions to many problems involving voltage level, power-factor correction, equipment loading, etc. Many shunt capacitors rated over 5000 kva and a few over 10 000 kva are in operation. Undoubtedly the same evolution is now in process with series capacitors. Several series capacitors rated over 1000 kva and one installation of 10 000 kva have been installed. Perhaps the "ice" has been broken and other large installations will follow. Experience gained on the 10 000-kva installation certainly indicates that large series capacitors applied carefully are economical and successful in operation. Still further progress is likely to result from studies now being made on the application of large series capacitors to extra-high-voltage transmission lines. A large series capacitor is now being installed and tested in a 230-kv line in the Pacific Northwest.

REFERENCES

Shunt Capacitors

1. Capacitors Reduce Losses and Raise Voltage, W. H. Cuttino *Southern Power and Industry*, October 1941.
2. Use the Right Capacitor with Induction Motors, J. B. Owens, *Factory Management and Maintenance*, May 1945.
3. Safe Capacitor Selection for Power Factor Improvement, J. E. Barkle, *Power*, April 1943.
4. Uses of Capacitors, R. E. Marbury, *Electric Journal*, Vol. 33, July 1936, pp. 303-306.
5. Capacitors—Design, Application, Performance, M. C. Miller, *Electric Light and Power*, Vol. 16, October 1938, pp. 46-50.
6. Shunt Capacitors Reduce KVA Loads, C. M. Lytle and S. H. Pollock, *Electric Light and Power*, Vol. 15, November 1937, pp. 52-54.
7. Capacitors Defer \$135,000 Investment in Synchronous Unit, J. F. Roberts, *Electrical West*, Vol. 83, October 1939, pp. 42-43.
8. Shunt Capacitor Application Problems, J. W. Butler, *General Electric Review*, Vol. 43, May 1940, pp. 206-212.
9. Current Control Broadens Capacitor Application, A. D. Caskey, *Electric Light and Power*, Vol. 18, February 1940, pp. 49-51.
10. Seventeen Systems Report Smooth Capacitor Performance, M. C. Miller, *Electrical World*, Vol. 113, January 27, 1940 pp. 289, 339-340.
11. Facilities for the Supply of Kilowatts and Kilovars, Hollis K. Sels and Theodore Seely, *A.I.E.E. Transactions*, Vol. 61, May 1942, p. 249.
12. Kilowatts, Kilovars, and System Investment, J. W. Butler, *A.I.E.E. Transactions*, Vol. 62, March 1943, pp. 133-137.
13. Mobile Capacitor Units for Emergency Loading of Transformers in Open Delta, H. B. Wolf and G. G. Mattison, *A.I.E.E. Transactions*, Vol. 62, February 1943, pp. 83-86.
14. The 13,500 KVAR Capacitor Installation at Newport News, E. L. Harder and V. R. Parrack, Southeastern Meeting of AIEE, Roanoke, Va., November 16, 1943.
15. Analysis of Factors Which Influence the Application, Operation, and Design of Shunt Capacitor Equipments Switched in Large Banks, J. W. Butler, AIEE Great Lakes District Meeting, Minneapolis, Minn., September 27-29, 1939.
16. Extending the Use of Shunt Capacitors by Means of Automatic Switching, W. H. Cuttino, AIEE Summer Meeting, St. Louis, Missouri, June 26-30, 1944.
17. Tests and Analysis of Circuit Breaker Performance When Switching Large Capacitor Banks, T. W. Schroeder, E. W. Boehne, and J. W. Butler, *A.I.E.E. Transactions*, Vol. 62, 1943, pp. 821, 831.
18. Automatic Switching Schemes for Capacitors, W. H. Cuttino, *A.I.E.E. Transactions*, Vol. 66, 1947.
19. Power Capacitors (Book), R. E. Marbury, McGraw-Hill Book Co., Inc., New York, N. Y., 1949.
20. The Why of a 25-KVAR Capacitor, M. E. Scoville, *General Electric Review*, Vol. 52, No. 5, May 1949.

Series Capacitors

21. Series Capacitors, R. E. Marbury and W. H. Cuttino, *Electric Journal*, March 1936.
22. Analysis of Series Capacitor Application Problems, J. W. Butler and C. Concordia, *A.I.E.E. Transactions*, Vol. 56, 1937, p. 975.
23. Series Capacitors for Transmission Circuits, E. C. Starr and R. D. Evans, *A.I.E.E. Transactions*, Vol. 61, 1942, p. 963.
24. Characteristics of 400-Mile 230-KV Series Capacitors, B. V. Hoard, *A.I.E.E. Transactions*, Vol. 65, 1946, p. 1102.
25. Design and Protection of 10,000-KVA Series Capacitor for 66-KV Transmission Line, A. A. Johnson, R. E. Marbury, J. M. Arthur, *A.I.E.E. Transactions*, Vol. 67, 1948.
26. 10 000 KVA Series Capacitor Improves Voltage in 66-KV Line Supplying Large Electric Furnace Load, B. M. Jones, J. M. Arthur, C. M. Stearns, A. A. Johnson, *A.I.E.E. Transactions*, Vol. 67, 1948.
27. Design and Layout of 66-KV 10 000-KVA Series Capacitor Substation, G. B. Miller, *A.I.E.E. Transactions*, Vol. 67, 1948.
28. New Series Capacitor Protective Device, R. E. Marbury and J. B. Owens, *A.I.E.E. Transactions*, Vol. 65, 1946, p. 142.
29. Self-Excitation of Induction Motors with Series Capacitors, C. F. Wagner, *A.I.E.E. Transactions*, Vol. 60, 1941 p. 1241.
30. Steady-State and Transient Stability Analysis of Series Capacitors in Long Transmission Lines, Butler, Paul, Schroeder, *A.I.E.E. Transactions*, Vol. 62, 1943, p. 58.
31. Series Capacitors Approach Maturity, A. A. Johnson, *Westinghouse ENGINEER*, Vol. 8, July 1948, pp. 106-111.
32. Application Considerations of Series Capacitors, A. A. Johnson, *Westinghouse ENGINEER*, Vol. 8, September 1948, pp. 155-156.

CHAPTER 9

REGULATION AND LOSSES OF TRANSMISSION LINES

Original Author:

G. D. McCann

Revised by:

R. F. Lawrence

THIS chapter deals with problems relating to the performance of transmission lines under normal operating conditions. The analytical expressions for currents and voltages and the equivalent circuits for transmission lines are first developed for "short" lines and for "long" lines (where the effects of distributed line capacitance must be taken into account). A simplification is presented in the treatment of long lines that greatly clarifies their analysis and reduces the amount of work necessary for calculations. Problems relating to the regulation and losses of lines and their operation under conditions of fixed terminal voltages are then considered. The circle diagrams are developed for short lines, long lines, the general equivalent π circuit, and for the general circuit using $ABCD$ constants. The circle diagrams are revised from the previous editions of the book to conform with the convention for reactive power which is now accepted by the American Institute of Electrical Engineers, so that lagging reactive power is positive and leading reactive power is negative.

When determining the relations between voltages and currents on a three-phase system it is customary to treat them on a "per phase" basis. The voltages are given from line to neutral, the currents for one phase, the impedances for one conductor, and the equations written for one phase. The three-phase system is thus reduced to an equivalent single-phase system. However, vector relationships between voltages and currents developed on this basis are applicable to line-to-line voltages and line currents if the impedance drops are multiplied by $\sqrt{3}$ for three-phase systems and by 2 for single-phase two-wire systems.

Most equations developed will relate the terminal conditions at the two ends of the line since they are of primary importance. These terminals will be called the sending end and receiving end with reference to the direction of normal flow of power, and the corresponding quantities designated by the subscripts S and R .

I. EQUIVALENT CIRCUITS FOR TRANSMISSION LINES

1. Short Transmission Lines

For all types of problems it is usually safe to apply the short transmission line analysis to lines up to 30 miles in length or all lines of voltages less than about 40 kv. The importance of distributed capacitance and its charging current varies not only with the characteristics of the line but also with the different types of problems. For this reason no definite length can be stipulated as the dividing point between long and short lines.

Neglecting the capacitance a transmission line can be treated as a simple, lumped, constant impedance,

$$Z = R + jX = zs = rs + jxs$$

Where

- z = series impedance of one conductor in ohms per mile
- r^* = resistance of one conductor in ohms per mile
- x^* = inductive reactance of one conductor in ohms per mile
- s = length of line in miles

The corresponding "per phase" or equivalent single-phase circuit is shown in Fig. 1 together with the vector diagram

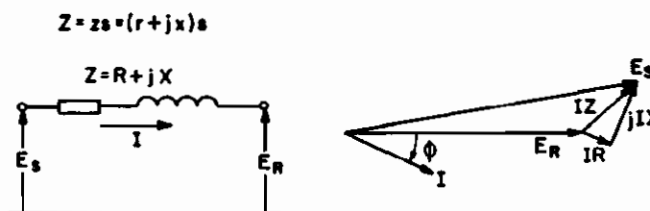

**EQUIVALENT TRANSMISSION
CIRCUIT TO NEUTRAL**

Fig. 1—Equivalent circuit and vector diagram for short transmission lines.

relating the line current and the line-to-neutral voltages at the two ends of the line.

The analytical expression for this relationship is given by the equation:

$$E_s = E_R + ZI \tag{1}$$

Throughout this chapter, the following symbols are used:

- E —is a vector quantity
- \bar{E} —is the absolute magnitude of the quantity
- \hat{E} —is the conjugate of the vector quantity

2. Long Transmission Lines

The relative importance of the charging current of the line for all types of problems varies directly with the voltage of the line and inversely with the load current. To appreciate this fully it is necessary to consider the analysis of "long" lines.

A "long" transmission line can be considered as an infinite number of series impedances and shunt capacitances connected as shown in Fig. 2. The current I_R is unequal to I_S in both magnitude and phase position because some current is shunted through the capacitance between phase

*These quantities can be obtained from the tables of conductor characteristics of Chap. 3.

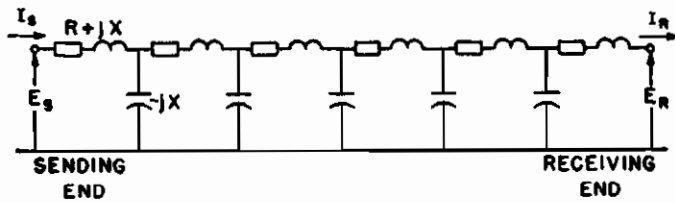

Fig. 2—Diagram representing long transmission lines.

and neutral. The relationship between E_S and E_R for a "long" line is different from the case of the short line because of the progressive change in the line current due to the shunt capacitance. If E_S and E_R are considered as phase-to-neutral voltages and I_S and I_R are the phase currents, the classical equations relating the sending-end voltages and currents to the receiving-end quantities are:

$$E_S = E_R \cosh (s\sqrt{zy}) + I_R \sqrt{\frac{z}{y}} \sinh (s\sqrt{zy}) \quad (2)$$

$$I_S = \frac{E_R}{\sqrt{\frac{z}{y}}} \sinh (s\sqrt{zy}) + I_R \cosh (s\sqrt{zy}) \quad (3)$$

The susceptance, y , heretofore has been used most frequently in these expressions. However, with the advent of the new form of tables giving characteristics of conductors, the shunt-capacitive reactance is obtained as a function of the conductor size and equivalent spacing. The reciprocal of y , which is x' is therefore a more convenient quantity to use. For this reason the concept of shunt-capacitive reactance is used throughout this chapter. Eqs. (2) and (3) then become:

$$E_S = E_R \cosh \left(s\sqrt{\frac{z}{z'}} \right) + I_R \sqrt{zz'} \sinh \left(s\sqrt{\frac{z}{z'}} \right) \quad (4)$$

$$I_S = \frac{E_R}{\sqrt{zz'}} \sinh \left(s\sqrt{\frac{z}{z'}} \right) + I_R \cosh \left(s\sqrt{\frac{z}{z'}} \right) \quad (5)$$

where z is the series impedance of one conductor in ohms per mile, z' is the shunt impedance of the line in ohms per mile, s is the distance in miles.

$$z' = -jx'(10)^6$$

x'^* = capacitive reactance in megohms per mile.

Equations (4) and (5) can be written conveniently in terms of the conventional $ABCD$ constants.⁴ For the case of a transmission line the circuit is symmetrical and D is equal to A . (Refer to Chapter 10, Section 21 for definition of $ABCD$ constants.)

$$E_S = AE_R + BI_R \quad (6)$$

$$I_S = CE_R + DI_R = CE_R + AI_R \quad (7)$$

$$E_R = AE_S - BI_S \quad (8)$$

$$I_R = -CE_S + DI_S = -CE_S + AI_S \quad (9)$$

where

$$A = \cosh \left(s\sqrt{\frac{z}{z'}} \right) = \cosh \sqrt{\frac{Z}{Z'}} \quad (10)$$

*This quantity can be obtained from the tables of conductor characteristics in Chap. 3. It is given in megohms in tables as it is then of the same order of magnitude as the inductive reactance.

in which

$$Z = zs \text{ and } Z' = \frac{z'}{s}$$

$$B = \sqrt{zz'} \sinh \left(s\sqrt{\frac{z}{z'}} \right) = \sqrt{ZZ'} \sinh \sqrt{\frac{Z}{Z'}} \quad (11)$$

$$C = \frac{1}{\sqrt{zz'}} \sinh \left(s\sqrt{\frac{z}{z'}} \right) = \frac{1}{\sqrt{ZZ'}} \sinh \sqrt{\frac{Z}{Z'}} \quad (12)$$

The values of the hyperbolic functions can be obtained from tables² or charts³ or from evaluation of their equivalent series expressions

$$\cosh \left(s\sqrt{\frac{z}{z'}} \right) = \cosh \theta = \left(1 + \frac{\theta^2}{2!} + \frac{\theta^4}{4!} + \frac{\theta^6}{6!} + \dots \right) \quad (13)$$

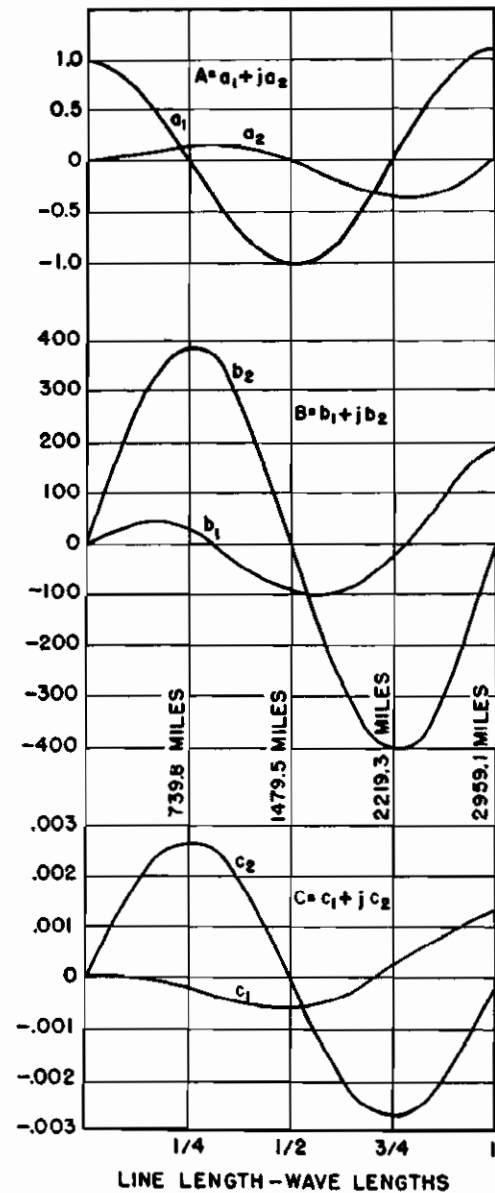

Fig. 3—Variation of the real and imaginary components of A , B , and C for a 795 000 circular mils ACSR, 25-foot equivalent spacing, transmission line.

$$r = 0.117 \text{ ohm per mile.}$$

$$x = 0.7836 \text{ ohm per mile.}$$

$$x' = 0.1859 \text{ megohm per mile.}$$

$$\sinh \left(s\sqrt{\frac{Z}{Z'}} \right) = \sinh \theta = \left(\theta + \frac{\theta^3}{3!} + \frac{\theta^5}{5!} + \frac{\theta^7}{7!} + \dots \right) \quad (14)$$

Expressed in terms of their equivalent series expansions, the ABC constants become

$$A = \left[1 + \frac{Z}{2Z'} + \frac{Z^2}{24Z'^2} + \frac{Z^3}{720Z'^3} + \frac{Z^4}{40320Z'^4} + \dots \right] \quad (15)$$

$$B = Z \left[1 + \frac{Z}{6Z'} + \frac{Z^2}{120Z'^2} + \frac{Z^3}{5040Z'^3} + \frac{Z^4}{362880Z'^4} + \dots \right] \quad (16)$$

$$C = \frac{1}{Z'} \left[1 + \frac{Z}{6Z'} + \frac{Z^2}{120Z'^2} + \frac{Z^3}{5040Z'^3} + \frac{Z^4}{362880Z'^4} + \dots \right] \quad (17)$$

The series are carried out far enough so that the ABC constants can be determined to a high degree of accuracy. However, for lines approaching one quarter wave length, the series do not converge rapidly enough. In such a case it is better to determine the ABC constants for the line in two sections and combine them as described in Chapter 10, Table 9.

The ABC constants can be determined easily for any length of line by an evaluation of the cosh and sinh functions using the hyperbolic and trigonometric functions. The procedure is outlined briefly here.

$$\theta = s\sqrt{\frac{Z}{Z'}} = \alpha + j\beta$$

where α and β are in radians.

$$\begin{aligned} \cosh \theta &= \cosh \alpha \cos \beta + j \sinh \alpha \sin \beta \\ \sinh \theta &= \sinh \alpha \cos \beta + j \cosh \alpha \sin \beta \end{aligned}$$

where:

$$\begin{aligned} \cosh \alpha &= \frac{e^\alpha + e^{-\alpha}}{2} \\ \sinh \alpha &= \frac{e^\alpha - e^{-\alpha}}{2} \end{aligned}$$

Figure 3 shows the variation of the ABC constants as a function of line length for the line of Fig. 18. The real and imaginary parts of A, B, and C are shown for a complete wave length.

3. The Equivalent π of a Transmission Line

There are several equivalent circuits that represent the above transmission line equations and thus can be used for the representation of transmission lines. One such circuit is the equivalent π shown in Fig. 4.

Referring to this figure the equations relating the terminal conditions for this circuit are

$$\begin{aligned} I_R' &= \frac{E_R}{Z'_{eq}} \\ E_S &= E_R + Z_{eq} \left(I_R + \frac{E_R}{Z'_{eq}} \right) \\ E_S &= E_R \left(1 + \frac{Z_{eq}}{Z'} \right) + Z_{eq} I_R \end{aligned} \quad (18)$$

$$\begin{aligned} I_S' &= \frac{E_S}{Z'_{eq}} \\ I_S &= I_R + I_R' + I_S' = \frac{E_R}{Z'_{eq}} + \frac{E_S}{Z'_{eq}} + I_R \\ I_S &= \left(\frac{2}{Z'_{eq}} + \frac{Z_{eq}}{Z'^2} \right) E_R + \left(1 + \frac{Z_{eq}}{Z'_{eq}} \right) I_R \end{aligned} \quad (19)$$

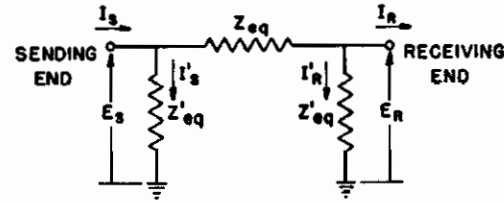

Fig. 4—Equivalent π circuit for representing long transmission lines.

By equating like coefficients of the equivalent Eqs. (18) and (6)

$$Z_{eq} = B \quad (20)$$

$$1 + \frac{Z_{eq}}{Z'_{eq}} = A \quad (21)$$

Giving for the equivalent impedance Z'_{eq}

$$Z'_{eq} = \frac{B}{A-1} \quad (22)$$

Expressed in terms of the corresponding hyperbolic functions and their equivalent series the equations for the impedances are

$$\begin{aligned} Z_{eq} &= \sqrt{ZZ'} \sinh \sqrt{\frac{Z}{Z'}} = Z \left(1 + \frac{Z}{6Z'} + \frac{Z^2}{120Z'^2} \right. \\ &\quad \left. + \frac{Z^3}{5040Z'^3} + \frac{Z^4}{362880Z'^4} \right) \end{aligned} \quad (23)$$

$$\begin{aligned} Z'_{eq} &= \frac{\sqrt{ZZ'} \sinh \sqrt{\frac{Z}{Z'}}}{\left(\cosh \sqrt{\frac{Z}{Z'}} - 1 \right)} = 2Z' \left(1 + \frac{Z}{12Z'} - \frac{Z^2}{720Z'^2} \right. \\ &\quad \left. + \frac{Z^3}{30240Z'^3} - \frac{Z^4}{1207600Z'^4} + \dots \right) \end{aligned} \quad (24)$$

4. Equivalent T of a Transmission Line

Another equivalent circuit for a transmission line is shown in Fig. 5. The equations for the impedances of this circuit are

$$\begin{aligned} Z_T &= \frac{A-1}{C} = \frac{Z}{2} \left(1 - \frac{Z}{12Z'} + \frac{Z^2}{120Z'^2} - \frac{17Z^3}{20160Z'^3} \right. \\ &\quad \left. + \frac{31Z^4}{362880Z'^4} - \dots \right) \end{aligned} \quad (25)$$

$$\begin{aligned} Z'_T &= \frac{1}{C} = Z' \left(1 - \frac{Z}{6Z'} + \frac{7Z^2}{360Z'^2} - \frac{31Z^3}{15120Z'^3} \right. \\ &\quad \left. + \frac{127Z^4}{604800Z'^4} - \dots \right) \end{aligned} \quad (26)$$

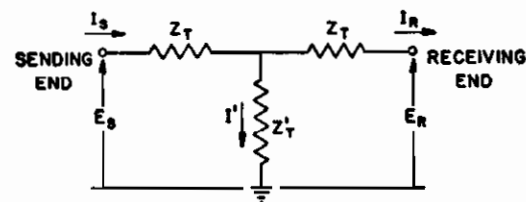

Fig. 5—Equivalent T circuit for representing long transmission lines.

5. Comparison of the Equivalent π vs. ABCD Constants

The choice of the use of the equivalent π vs. $ABCD$ constants in calculating transmission-line constants is largely a matter of personal preference. However, each offers certain advantages over the other. When the network calculator is to be used, it is necessary to set up an actual circuit in the form of the equivalent π . The equivalent π affords a better physical picture of transmission-line performance and makes the comparison between long and short lines and the effect of charging current easier to visualize.

On the other hand, when a problem is to be solved analytically, the use of $ABCD$ constants has a definite advantage over the equivalent π because of the availability of the independent check: $AD - BC = 1$. This is particularly desirable when other circuits are to be combined with the transmission line circuit.

The equivalent π or $ABCD$ constants can be used to represent any line, section of line, or combination of lines and connected equipment. Either one represents accurately all conditions at the two terminals of the system. The equivalent circuit or $ABCD$ constants being considered here pertains only to a single line or line section. The general equivalent circuit and general $ABCD$ constants, if so desired, can be determined by the combination of the equivalent circuits for the rest of the system as discussed in Chapter 10.

6. Expressions for Transmission Line Constants by First Two Terms of Their Series

When considering the accuracy with which transmission line circuit constants need be determined, it should be realized that the resistance, inductance, and capacitance of a line can rarely be known to within 3 or 4 percent and probably never within one per cent. This is due to conductor sag, its variation with different spans, and the variation that exists in conductor spacing together with the effects of temperature upon conductor resistivity and sag. For this reason equations for the above circuit constants that are accurate to within 0.5 percent should be satisfactory.

The effect of neglecting all but the first two terms of the series in the above expressions can best be shown by considering an actual line. For a 300-mile line with 250 000 circular mil stranded copper and a 35-foot spacing the third term in all of the above series expressions is larger than normal.

For this line, from the conductor tables of Chap. 3

$$r = 0.257 \text{ ohms per mile}$$

$$x = x_a + x_d = 0.487 + 0.431 = 0.918 \text{ ohms per mile}$$

$$x' = x_a' + x_d' = 0.111 + 0.106 = 0.217 \text{ megohms per mile}$$

$$Z = rs + jxs = (77.1 + j275.4) \text{ ohms}$$

$$Z' = -j \frac{x' 10^6}{s} = -j723.3 \text{ ohms}$$

$$\frac{Z}{Z'} = \frac{77.1 + j275.4}{-j723.3} = -0.3807 + j0.1066$$

$$\frac{Z^2}{Z'^2} = 0.1335 - j0.08117$$

For the third term in the series expression for A

$$\frac{Z^2}{24Z'^2} = 0.0056 - j0.0034$$

This term is thus about 0.6 percent of one (the first term).

For the third term in the expression for Z_T .

$$\frac{Z^2}{120Z'^2} = 0.0011 - j0.00067$$

which is about 0.1 percent of one (the first term).

For all the rest of the constants the term is less than 0.1 percent.

Since these terms vary with the fourth power of the length of the line, they decrease rapidly for lines less than 300 miles in length and can be neglected. For instance for a 150-mile line the terms are one-sixteenth as large as for a 300-mile line.

Thus the above transmission line constants can be expressed sufficiently accurately by the following equations which were derived from Eqs. (15), (16), (17), (23), (24), (25), and (26) by neglecting all but the first two terms of each series expression.

$$A = \left(1 - \frac{xS^2}{200x'}\right) + j \frac{rS^2}{200x'} \quad (27)$$

$$B = Z_{eq} = 100rS \left(1 - \frac{xS^2}{300x'}\right) + j100xS \left(1 - \frac{xS^2}{600x'} + \frac{r^2S^2}{600xx'}\right) \quad (28)$$

$$C = \frac{jS}{x'} \left[\left(1 - \frac{xS^2}{600x'}\right) + j \frac{rS^2}{600x'} \right] 10^{-4} \quad (29)$$

$$Z'_{eq} = -j \frac{2x'}{S} \left[\left(1 - \frac{xS^2}{1200x'}\right) + j \frac{rS^2}{1200x'} \right] 10^4 \quad (30)$$

$$Z_T = 50rS \left(1 + \frac{xS^2}{1200x'}\right) + j50xS \left(1 + \frac{xS^2}{1200x'} - \frac{r^2S^2}{1200xx'}\right) \quad (31)$$

$$Z_T' = -j \frac{x'}{S} \left[\left(1 + \frac{xS^2}{600x'}\right) - j \frac{rS^2}{600x'} \right] 10^4 \quad (32)$$

In these equations:

S = length of line in hundreds of miles.

x and r are in ohms per mile, and x' in megohms per mile.

7. Simplified Method of Determining the Impedances of the Equivalent π Circuit for Transmission Lines

The following method greatly simplifies the determination of the impedances of the equivalent π circuit and still enables them to be determined to within 0.5 percent for all practical power transmission lines.

Equations (28) and (30) can be expressed in the following form:

$$Z_{eq} = 100rSK_r + j100xSK_x \quad (33)$$

$$Z'_{eq} = -j \frac{2x'}{S} (k_r + jk_x) 10^4 \quad (34)$$

where

$$K_r = 1 - \frac{xS^2}{300x'} \quad (35)$$

$$K_x = 1 - \frac{S^2}{600} \left(\frac{x}{x'} - \frac{r^2}{xx'} \right) \quad (36)$$

$$k_r = 1 - \frac{xS^2}{1200x'} \quad (37)$$

$$k_x = \frac{rS^2}{1200x'} \quad (38)$$

Examination of the above equations shows that for a given line, the factors K_r , K_x , and k_r differ from 1 by a term that is proportional to the square of the length of the line. However, a study of the characteristics of lines which it is economical to build and that have been built in the United States reveals that for a given length the variance of these correction factors from a mean is very slight. In addition, it is only the lines with smaller conductor sizes and equivalent spacings for which the correction factors vary appreciably.

TABLE 1.—MINIMUM CONDUCTOR SIZES AND SEPARATIONS FOR WHICH THE MEAN VALUES OF THE CORRECTION FACTORS ARE APPLICABLE TO AN ACCURACY OF WITHIN ONE-HALF OF ONE PERCENT⁽¹⁾

Length of Line in Miles	50	75	150	200	300
G.M.D. (ft.)	3	6	6	10	14
Copper Cables	6	2	0	300 000	500 000
A.C.S.R.	1	1	000	500 000	795 000
An Hollow Cu. Cable	00 ⁽²⁾	00	00	300 000	500 000
Gen. Cable Type HH	000 ⁽²⁾	000	000	300 000	500 000

⁽¹⁾ Conductor sizes are in cir. mils or AWG.

⁽²⁾ Smallest sizes made.

Table 1 gives minimum conductor sizes and spacings for various lengths of line for which the use of mean correction factors will give sufficient accuracy. For lines up to 300 miles in length with conductor sizes and spacings equal to or greater than given by this table, the use of mean values for K_r , K_x , and k_r gives an accuracy of within 0.5 percent. The correction factor k_x is never greater than about 0.005 and can be neglected. Thus, the shunt impedance Z'_{eq} can be considered as a pure capacitor.

In Fig. 6 are plotted the curves for K_r , K_x , and k_r as a function of line length. The values on these curves conform to those of the most common type of line construction that is used for a given line length. Thus, in most cases the use of these values will give an accuracy considerably better than 0.5 percent. The factors can also

TABLE 2—EXPRESSIONS FOR THE CORRECTION FACTORS FOR THE EQUIVALENT π IMPEDANCES

Correction Factors	Values for Line Lengths up to				
	50 Mi.	75 Mi.	100 Mi.	200 Mi.	300 Mi.
K_r	$1 - 0.0141 S^2$				
K_x	1	$1 - 0.0069 S^2$			
k_r	1	$1 - 0.0035 S^2$			
k_x	0				

S is the length of the line expressed in hundreds of miles.

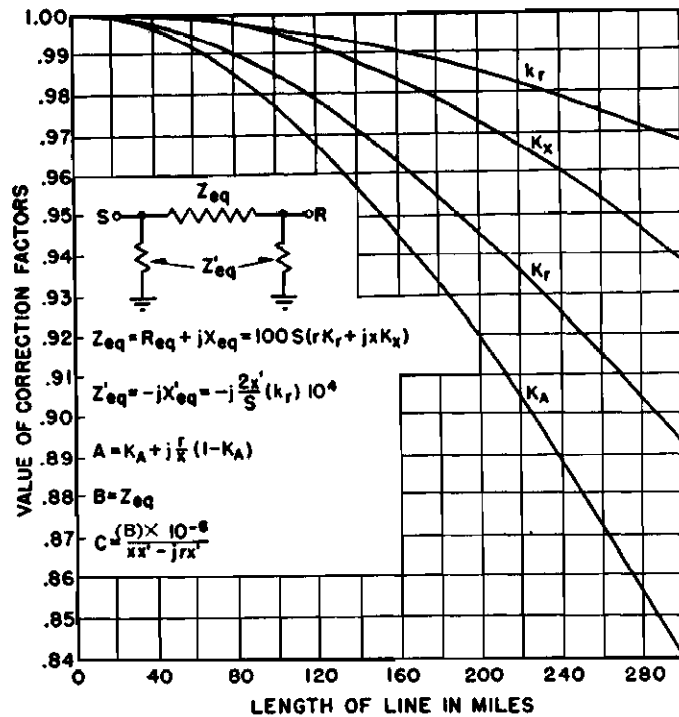

Fig. 6—Correction factors for the equivalent π transmission line impedances and ABC constants at 60 cycles.

S = length of line in hundreds of miles.

r = conductor resistance in ohms per mile.

x = inductive reactance in ohms per mile.

x' = capacitive reactance in megohms per mile.

be expressed to sufficient accuracy as parabolic equations of the type $1 - KS^2$. In Table 2 are tabulated the correction factors expressed in this form. The curves constructed from these equations conform closely to the curves of Fig. 6. Table 2 shows that K_r can be considered as 1 up to 50 miles, K_x as 1 up to 75 miles, and k_r as 1 up to 100 miles. Since in practically all cases the individual sections of line to be considered are not over 100 miles long, the correction factors can be neglected entirely if an accuracy of better than $1\frac{1}{2}$ percent is not desired. The largest deviation from unity is in K_r , which at 100 miles is only 1.4 percent.

Example 1—As an example of the use of this method in determining the equivalent π of a transmission line, consider a three-phase, 60-cycle, 230-mile line of 500 000 circular mil stranded copper conductors at an equivalent spacing of 22 feet.

From the Tables of Chap. 3

$$r = 0.130 \text{ ohms per mile}$$

$$x = 0.818 \text{ ohms per mile}$$

$$x' = 0.1917 \text{ megohms per mile}$$

From the curves of Fig. 6 for a 230 mile line

$$K_r = 0.931$$

$$K_x = 0.964$$

$$k_r = 0.982$$

From Eqs. (33) and (34) or Fig. 6

$$Z_{eq} = (0.130)(230)(0.931) + j(0.818)(230)(0.964)$$

$$= (27.8 + j181.4) \text{ ohms}$$

$$Z'_{eq} = -j \frac{2(0.1917)}{2.30} (0.982)(10^4)$$

$$Z'_{eq} = -j1635 \text{ ohms}$$

The equivalent circuit for this line is shown in Fig. 13.

8. Adaptation of Simplified Method of Determining Equivalent π to Determining ABC Constants

The foregoing method can be adapted with an acceptable degree of accuracy to determining the ABC constants of a transmission line. The ABC constants of the line should be determined by a more accurate method if the line is to be combined with other circuit elements. Eq. (27) can be written as follows:

$$A = K_A + j \frac{r}{x} (1 - K_A) \quad (39)$$

where
$$K_A = 1 - \frac{xS^2}{200x'}$$

Since K_A is the same form of correction factor as K_r (Eq. (35)), a new curve for the correction factor can be plotted as shown in Fig. 6. The constant A is readily obtained from the correction factor K_A and Eq. (39). The constant B is equal to Z_{eq} and is determined through the use of the correction factors K_r and K_x of Fig. 6.

From Eqs. (16) and (17) it can be seen that

$$C = \frac{B}{ZZ'} = \frac{B \times 10^{-6}}{xx' - jr x'} \quad (40)$$

where

- r = conductor resistance in ohms per mile.
- x = inductive reactance in ohms per mile.
- x' = capacitive reactance in megohms per mile.

Example 1(a)—Determine the ABC constants of the transmission line of example 1.

From the curves of Fig. 6, for a 230-mile line

$$K_A = 0.897$$

From the curve for K_A of Fig. 6 and from Eqs. (39) and (40)

$$A = 0.897 + j \frac{0.130}{0.818} (1 - 0.897)$$

$$= 0.897 + j0.0164$$

$$B = Z_{eq} = 27.8 + j181.4 \text{ ohms (from example 1)}$$

$$C = \frac{(27.8 + j181.4)(10^{-6})}{(0.818)(0.1917) - j(0.130)(0.1917)}$$

$$= -0.00000639 + j0.001156$$

II. REGULATION AND LOSSES

9. Analytical Solution for Voltage Regulation of Short Lines from Known Receiver Conditions

The commonest type of regulation problem is one in which it is desired to determine the voltage drop for known receiving-end conditions. For the solution of this problem it is more convenient to make E_R the reference vector as shown in Fig. 7(a). Unless denoted by the subscript L all voltages will be taken as line-to-neutral voltages. If line-

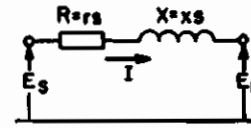

LAGGING POWER FACTOR LEADING POWER FACTOR

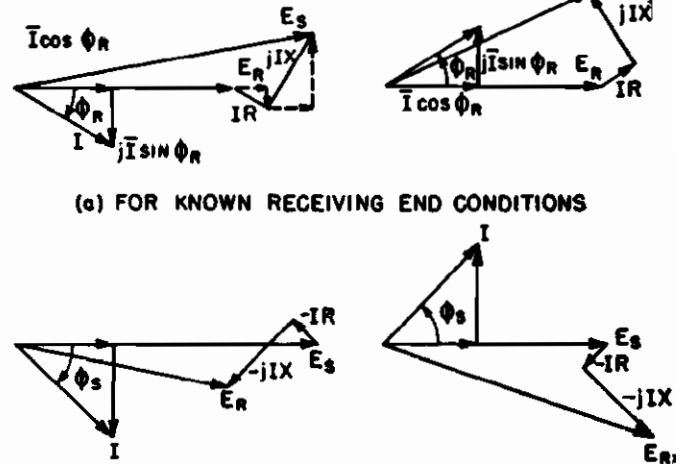

(a) FOR KNOWN RECEIVING END CONDITIONS
(b) FOR KNOWN SENDING END CONDITIONS
Fig. 7—Vector diagrams for determining voltage regulation of short lines.

to-line voltages are applied to the following voltage equations the impedance drop must be multiplied by $\sqrt{3}$ for three-phase lines or by 2 for single-phase lines.

In the following equations, (41) through (61), the sign of the power factor angle ϕ , depends upon whether the current is lagging or leading. For a lagging power factor, ϕ and $\sin \phi$ are negative; for a leading power factor, ϕ and $\sin \phi$ are positive. The \cos of ϕ is positive for either lagging or leading current.

$$E_R = \bar{E}_R = \text{reference}$$

$$I = \bar{I} \cos \phi_R + j \bar{I} \sin \phi_R$$

$$Z = R + jX = rs + jxs$$

$$E_S = E_R + IZ \quad (41)$$

or

$$E_S = (\bar{E}_R + \bar{I}R \cos \phi_R - \bar{I}X \sin \phi_R) + j(\bar{I}X \cos \phi_R + \bar{I}R \sin \phi_R) \quad (42)$$

In magnitude

$$\bar{E}_S = \sqrt{(\bar{E}_R + \bar{I}R \cos \phi_R - \bar{I}X \sin \phi_R)^2 + (\bar{I}X \cos \phi_R + \bar{I}R \sin \phi_R)^2} \quad (43)$$

If the $\bar{I}R$ and $\bar{I}X$ drops are not over 10 percent of \bar{E}_R , \bar{E}_S can be determined for normal power-factors to within a half percent by neglecting its quadrature component. Then

$$\bar{E}_S = \bar{E}_R + \bar{I}R \cos \phi_R - \bar{I}X \sin \phi_R \quad (44)$$

The voltage regulation of a line is usually considered as the percent drop with reference to E_R .

$$\text{Percent Reg.} = \frac{100(\bar{E}_S - \bar{E}_R)}{\bar{E}_R} \quad (45)$$

For exact calculations formula (43) can be used with Eq. 45.

Using the approximate formula (44) Eq. 45 can be written

$$\text{Percent Reg.} = \frac{100s\bar{I}}{\bar{E}_R}(r \cos \phi_R - x \sin \phi_R) \quad (46)$$

The load in kva delivered to the receiving end of a three-phase line is given by the equation

$$\text{KVA} = \frac{3\bar{E}_R\bar{I}}{1000} = \frac{\sqrt{3}\bar{E}_L\bar{I}}{1000} \quad (47)$$

where \bar{E}_L is the line voltage at the receiving end. The regulation expressed in terms of the load and the line-to-line voltage can be written

$$\text{Percent Reg.} = \frac{100\,000(\text{kva})(s)}{\bar{E}_L^2}(r \cos \phi_R - x \sin \phi_R) \quad (48)$$

These equations show that the amount of load that can be transmitted over a given line at a fixed regulation varies inversely with its length. Using the regulation calculated from these equations to determine the receiver-end voltage will give this quantity to $\frac{1}{2}$ percent if neither the resistance nor reactive drops exceed more than 10 percent of the terminal voltage. The percentage variance of the regulation from its own correct value, however, may be great, depending upon its actual magnitude and for this reason such equations are not accurate for determining load limits for fixed regulations.

Example 2—The use of these equations can be illustrated by calculating the regulation on a three-phase line five miles long having 300 000 circular mil stranded copper conductors at an equivalent spacing of four feet and carrying a load of 10 000 kva at 0.8 power-factor lag and a receiver line voltage of 22 000 volts.

$r = 0.215$ ohms per mi and $x = 0.644$ ohms per mi.

Applying Eq. (48)

$$\text{Percent Reg.} = \frac{(100\,000)(10\,000)(5)}{(22\,000)^2} \left[(0.215)(0.8) - (0.644)(-0.6) \right]$$

$$\text{Reg.} = 5.8\%$$

10. Voltage Regulation of Short Lines from Known Sending-End Conditions

To calculate the receiving-end voltage from known sending-end conditions it is more convenient to use E_S as the reference vector as shown in Fig. 7(b). For this case

$$\begin{aligned} E_S &= \bar{E}_S = \text{reference} \\ E_R &= E_S - IZ \end{aligned} \quad (49)$$

$$E_R = (\bar{E}_S - \bar{I}R \cos \phi_S + \bar{I}X \sin \phi_S) - j(\bar{I}X \cos \phi_S + \bar{I}R \sin \phi_S) \quad (50)$$

$$\bar{E}_R = \sqrt{(\bar{E}_S - \bar{I}R \cos \phi_S + \bar{I}X \sin \phi_S)^2 + (\bar{I}X \cos \phi_S + \bar{I}R \sin \phi_S)^2} \quad (51)$$

Neglecting the quadrature component of E_R :

$$\bar{E}_R = \bar{E}_S - \bar{I}R \cos \phi_S + \bar{I}X \sin \phi_S \quad (52)$$

11. Problems Containing Mixed Terminal Conditions

Sometimes problems are encountered in which mixed terminal conditions are given, such as load power factor

and sending-end voltage, or sending-end power factor and receiver-end voltage, and it is desired to determine the unknown voltage for given load currents. Such problems can not readily be solved by analytical methods. For instance, if it were desired to determine the receiver voltage from known load power factor, sending end voltage, and current, it would be necessary to solve for E_R in Eq. (43) by squaring both sides of the equation and obtaining a quadratic equation for E_R . This is somewhat cumbersome. Trial and error methods assuming successive values of one of the two unknown quantities, are often more convenient. Also, it is sometimes found easier to solve such problems by graphical means. The more important problems of this type can be solved by use of the Regulation and Loss Chart as shown in Sec. 28(d) of this chapter.

12. Taps Taken Off Circuit

Quite frequently the main transmission circuit is tapped and power taken off at more than one point along the circuit. For such problems it is necessary to solve each individual section in succession in the same manner as discussed above, starting from a point at which sufficient terminal conditions are known.

13. Resistance Losses of Short Transmission Lines

The total $R\bar{I}^2$ loss of a three-phase line is three times the product of the total resistance of one conductor and the square of its current.

$$\text{Loss} = 3R\bar{I}^2 \text{ in watts.} \quad (53)$$

In percent of the delivered kw. load

$$\text{Percent Loss} = \frac{173rs\bar{I}}{\bar{E}_L \cos \phi_R} \quad (54)$$

It is sometimes desired to determine the amount of power that can be delivered without exceeding a given percent loss. This is given by

$$\text{KW} = \frac{\bar{E}_L^2 \cos^2 \phi_R (\% \text{ Loss})}{100\,000rs} \quad (55)$$

This equation shows that the amount of power that can be transmitted for a given percent loss varies inversely with the length of the line and directly with the loss.

14. Regulation of Long Lines from Known Receiver Conditions

The effect of charging current on the regulation of transmission lines can be determined from the equivalent π circuit. In Fig. 8(a) are shown the vector diagrams for the case of known load conditions. The voltage drop in the series impedance Z_{eq} is produced by the load current

I_R plus the charging current $\frac{E_R}{Z'_{eq}}$ flowing through the shunt impedance at the receiver end of the line. For a given line this latter current is dependent only upon the receiver voltage E_R .

There are two methods of taking this charging current into account. One of these is to determine first the net current $\left(I'_{eq} = I_R + \frac{E_R}{Z'_{eq}} \right)$ that flows through Z_{eq} together with its power-factor angle ϕ_{eq} . Using the equivalent

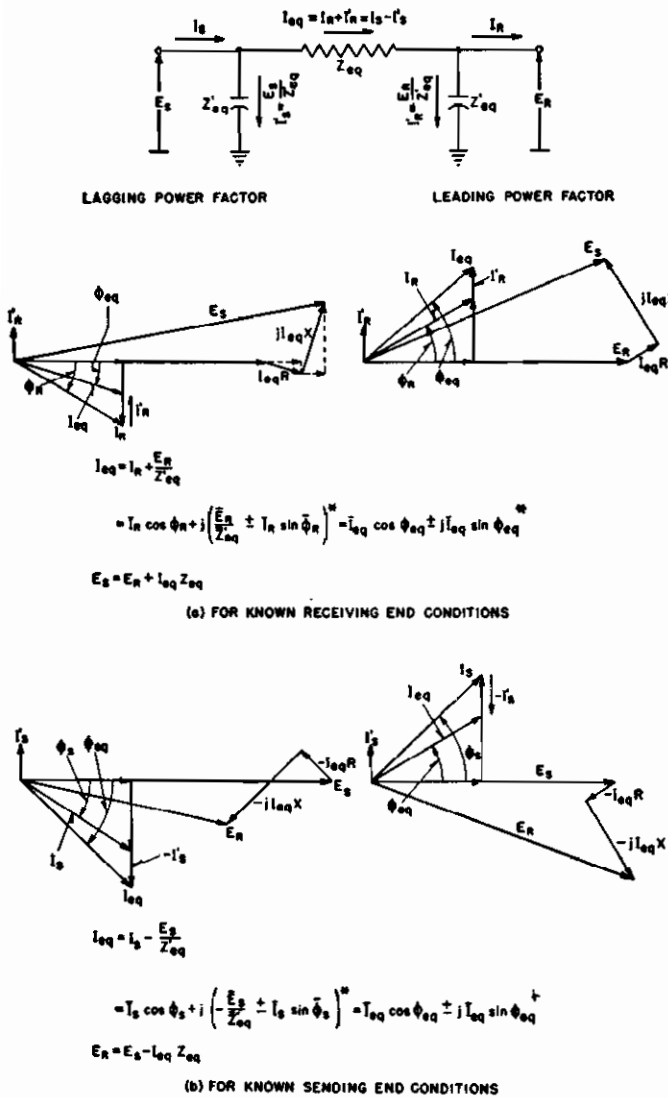

Fig. 8—Vector diagrams for determining voltage regulation of long lines.

series impedance Z_{eq} and this current instead of the load current all of the analytical expressions developed for short lines are applicable. The equivalent terminal conditions to use are shown in Fig. 8 (a).

Example 3—As an example of the use of this method consider the line of example 1, operating at a line voltage at the receiver end of 110 kv delivering a load current I_R of 50 amperes at 0.9 power-factor lagging.

$$E_R = (110,000 + j0) / \sqrt{3} = 63,500 + j0$$

$$I_R = 50 \epsilon^{-j25.8^\circ} = 50 [\cos(-25.8^\circ) + j \sin(-25.8^\circ)]$$

$$= 45 - j21.8 \text{ amps}$$

$$I'_R = \frac{E_R}{Z'_{eq}} = \frac{110,000 + j0}{\sqrt{3}(-j1635)} = +j38.8 \text{ amps}$$

$$I_{eq} = I_R + I'_R = 45 - j21.8 + j38.8 = 45 + j17 = 48.1 \epsilon^{j20.7^\circ}$$

$$Z_{eq} = 27.8 + j181.4 = 183.5 \epsilon^{j81.28^\circ}$$

$$E_S = 63,500 + (48.1 \epsilon^{j20.7^\circ})(183.5 \epsilon^{j81.28^\circ})$$

$$= 61,700 + j8640$$

*Sine of negative angle is (-), of positive angle is (+).

15. Regulation of Long Lines from Known Sending-End Conditions

For this case the equivalent current flowing through Z'_{eq} can be determined as the difference between I_S and I'_S the current in the shunt reactance at the sending end of the equivalent circuit. The vector diagram and equations for this case are shown in Fig. 8 (b).

16. Effect of Line Capacitance on Regulation Expressed in Terms of a Correction Factor

As an alternative method the voltage relations can be determined in a form equivalent to adding a correction factor to the terminal voltage instead of to the current. This method has an advantage in that an average value can be taken for this correction factor which is a function only of the length of the line.

Referring to the vector diagram of Fig. 8(a) for known receiving-end conditions and lagging power-factor, it is seen that the vector equation for the sending-end voltage E_S can be written in the following form in terms of the load current I_R and receiving-end voltage E_R if the current I'_R is expressed in terms of E_R :

$$E_S = \left(1 - \frac{X_{eq}}{Z'_{eq}}\right) \bar{E}_R + R_{eq} \bar{I}_R \cos \phi_R - X_{eq} \bar{I}_R \sin \phi_R$$

$$+ j \left(\frac{R_{eq}}{Z'_{eq}} \bar{E}_R + X_{eq} \bar{I}_R \cos \phi_R + R_{eq} \bar{I}_R \sin \phi_R \right) \quad (56)$$

When the quadrature component of E_S is neglected, its magnitude can be expressed as

$$\bar{E}_S = \left(1 - \frac{X_{eq}}{Z'_{eq}}\right) \bar{E}_R + R_{eq} \bar{I}_R \cos \phi_R - X_{eq} \bar{I}_R \sin \phi_R \quad (57)$$

From the same considerations that enabled average values to be taken for the correction factors of the equivalent π impedance discussed in Sec. 7 an average value can be assumed for $\frac{X_{eq}}{Z'_{eq}}$ in Eq. (57).

$$\frac{X_{eq}}{Z'_{eq}} = 0.0201S^2 \quad (58)$$

where S is the length of the line in hundreds of miles. An approximate expression can thus be obtained for the regulation of long lines similar to that of Eq. (46).

$$\text{App. } \% \text{ Reg.} = \frac{100 \bar{I}_R}{\bar{E}_R} (R_{eq} \cos \phi_R - X_{eq} \sin \phi_R) - 2.01S^2 \quad (59)$$

Similar analysis can be applied to problems involving known sending end conditions. A comparison of Eqs. (59) and (46) shows that when Z_{eq} is used for long lines, the equations are of the same form with the exception of the correction factor ($-2.01S^2$). For lines up to 100 miles in length short line formulas can usually be applied to a good degree of accuracy by merely adding this term to the result. This, of course, neglects the correction factors K_r and K_x for Z_{eq} .

17. Determination of Voltage at Intermediate Points on a Line

The voltage at intermediate points on a line may be calculated from known conditions at either terminal by simply setting up the equivalent circuit for the line be-

tween the terminal and the intermediate point. For the line thus set up any of the methods given above may be used.

18. Resistance Losses of Long Lines

The effect of charging current on line losses can be treated as in Sec. 14 for regulation. Referring to Fig. 8 the loss can be considered to be due to the current $I_{eq} = I_R + I_R' = I_S - I_S'$ flowing through the equivalent resistance (R_{eq}).

Thus in terms of the load current

$$\text{Loss} = 3R_{eq}(\bar{I}_R + \bar{I}_R')^2 \text{ watts} \quad (60)$$

$$= 3R_{eq} \left[\bar{I}_R^2 + \frac{2\bar{I}_R\bar{E}_R}{\bar{Z}'_{eq}} \sin \phi + \frac{\bar{E}_R^2}{\bar{Z}'_{eq}{}^2} \right] \text{ watts} \quad (61)$$

III. CIRCLE AND LOSS DIAGRAMS

Equations for line currents, power, and resistance losses can be expressed as functions of the terminal voltages and system constants. Such equations and graphical representations of them are found convenient not only for the more common types of performance problems but also in connection with system stability. The graphic form of the power and current equations are very similar and are known as "circle diagrams." Of these the power circle diagram is the most important. In the past this diagram has been primarily limited in its use to transmission systems. However, it is thought that if its simplicity and the clarity with which it depicts system performance are better understood, it will be applied more frequently to both transmission and distribution problems.

19. Vector Equations for Power

In previous editions of this book, lagging reactive power was considered as negative and leading reactive power positive. This conformed to the standard adopted by the American Institute of Electrical Engineers at that time. The convention has now been adopted as standard by the Institute that lagging reactive power be considered as positive and leading reactive power negative. Using this notation the vector expression for power can be written as the product of the voltage and the conjugate of the current.

$$P + jQ = E\hat{I} \quad (62)$$

This can be shown with reference to Fig. 9.

$$E = \bar{E} \cos \theta_e + j\bar{E} \sin \theta_e$$

$$I = \bar{I} \cos \theta_i + j\bar{I} \sin \theta_i$$

$$\hat{I} = \bar{I} \cos \theta_i - j\bar{I} \sin \theta_i$$

$$\begin{aligned} E\hat{I} &= \bar{E} (\cos \theta_e + j \sin \theta_e) \bar{I} (\cos \theta_i - j \sin \theta_i) \\ &= \bar{E}\bar{I} [(\cos \theta_e \cos \theta_i + \sin \theta_e \sin \theta_i) + j(\sin \theta_e \cos \theta_i \\ &\quad - \cos \theta_e \sin \theta_i)] \end{aligned}$$

since, $\cos(\theta_e - \theta_i) = \cos \theta_e \cos \theta_i + \sin \theta_e \sin \theta_i$

and $\sin(\theta_e - \theta_i) = \sin \theta_e \cos \theta_i - \cos \theta_e \sin \theta_i$

$$E\hat{I} = \bar{E}\bar{I} \cos(\theta_e - \theta_i) + j\bar{E}\bar{I} \sin(\theta_e - \theta_i)$$

Let ϕ be $\theta_e - \theta_i$; then for lagging or inductive power factors ϕ is positive and

$$P + jQ = E\hat{I} = \bar{E}\bar{I} \cos \phi + j\bar{E}\bar{I} \sin \phi.$$

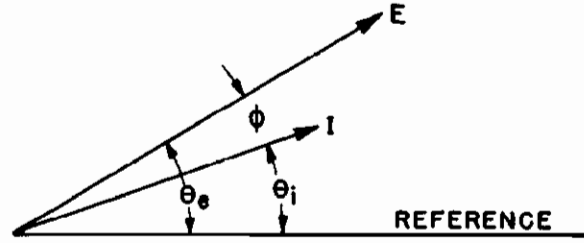

Fig. 9—Diagram for determining the vector equation for power.

For leading or capacitive power factor, ϕ is negative and the imaginary component will be negative. A complete discussion of the direction of the flow of reactive power is given in Chap. 10, Sec. 2.

20. Current and Power Equations and Circle Diagrams for Short Lines

Using the above notation the per phase power at either end of a line is given by the product of the line-to-neutral voltage and the conjugate of the current at the particular end in question. If I_S is chosen as positive for current flowing into the line, positive sending-end power indicates power delivered to the line; and if I_R is taken as positive for current flowing out of the line, positive receiving-end power indicates power flowing out of the line.

Referring to Fig. 1:

$$I_S = I_R = I$$

$$P_S + jQ_S = E_S\hat{I}$$

$$P_R + jQ_R = E_R\hat{I}$$

The current can be expressed in terms of the terminal voltage as follows:

$$I = \frac{E_S - E_R}{Z} \quad \text{also} \quad \hat{I} = \frac{\hat{E}_S - \hat{E}_R}{\hat{Z}} \quad (63)$$

Thus

$$P_S + jQ_S = \frac{E_S\hat{E}_S - E_S\hat{E}_R}{\hat{Z}}$$

$$P_R + jQ_R = \frac{-E_R\hat{E}_R + E_R\hat{E}_S}{\hat{Z}}$$

If E_R be taken as the reference, then $E_S = \bar{E}_S \epsilon^{j\theta}$ and $E_S\hat{E}_S = \bar{E}_S^2$; $E_S\hat{E}_R = \bar{E}_S\bar{E}_R \epsilon^{j\theta}$; $E_R\hat{E}_R = \bar{E}_R^2$; and $E_R\hat{E}_S = \bar{E}_R\bar{E}_S \epsilon^{-j\theta}$. The expressions for sending- and receiving-end power become

$$P_S + jQ_S = \frac{\bar{E}_S^2}{\hat{Z}} - \frac{\bar{E}_S\bar{E}_R \epsilon^{j\theta}}{\hat{Z}} \quad (64)$$

$$P_R + jQ_R = -\frac{\bar{E}_R^2}{\hat{Z}} + \frac{\bar{E}_S\bar{E}_R \epsilon^{-j\theta}}{\hat{Z}} \quad (65)$$

The sending and receiving end real and reactive power is the sum of two vector quantities. Furthermore, if the voltages E_S and E_R are held constant, there is only one remaining variable, θ . The interpretation of Eqs. (64) and (65) in the form of power circle diagrams is an important concept. Its simplicity is self evident by referring to Eq. (64) and Fig. 10.

The first term $\frac{\bar{E}_S^2}{\hat{Z}}$, is plotted as shown on Fig. 10 and is the vector to the center of the sending end circle diagram.

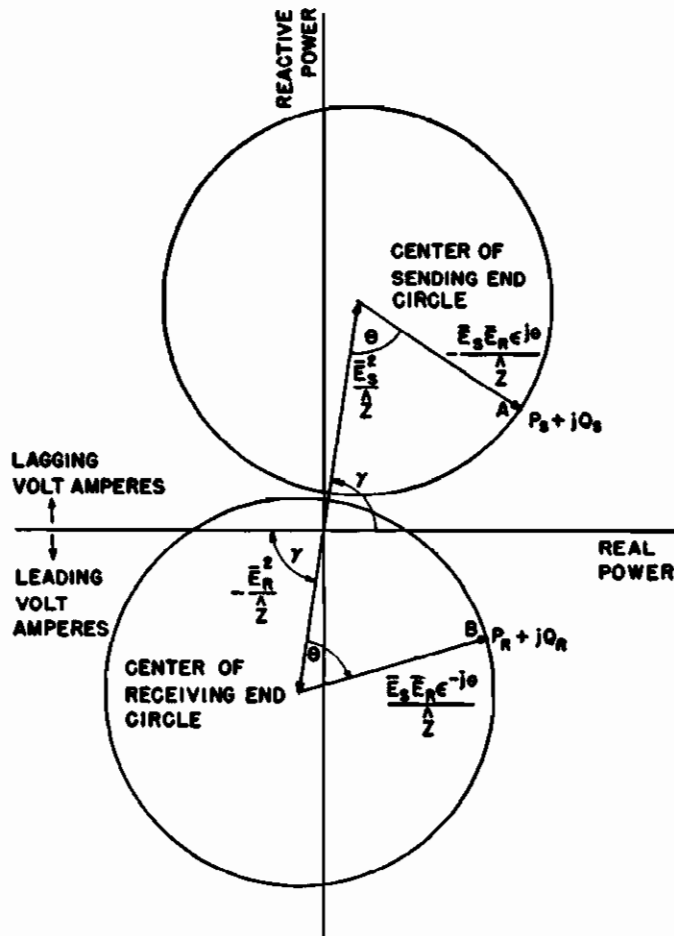

Fig. 10—Power circle diagram for short lines.

The second term $-\frac{\bar{E}_s \bar{E}_R \epsilon^{i\theta}}{Z}$, which is the radius of the circle is added to this first term so that the resultant is the sending end real and reactive power. A complete sending end circle diagram is obtained by first determining the center of the circle from $\frac{\bar{E}_s^2}{Z}$, and second, the radius $-\frac{\bar{E}_s \bar{E}_R \epsilon^{i\theta}}{Z}$, letting $\theta=0$.

The receiving-end circle diagram is obtained in the same manner.

Equations (64) and (65) can be reduced in general terms to Cartesian coordinate form in which the real and reactive parts are separated. However, it is simpler to insert the proper numerical values in the vector and conjugate form and solve by polar and Cartesian coordinates, from which the circle diagrams can then be plotted.

If Eq. (65) is reduced to Cartesian-coordinate form it can be shown that the maximum power that can be received over the line is obtained when θ is equal to $\gamma = \tan^{-1} \frac{x}{r}$, the angle of the line impedance. The expression for the maximum receiving power is

$$P_R \text{ max} = -\frac{\bar{E}_R^2}{Z^2} R + \frac{\bar{E}_s \bar{E}_R}{Z}. \quad (66)$$

It can also be seen from Fig. 10 that P_R is maximum when $\theta = \gamma$.

When the line-to-neutral voltages are expressed in volts,

the coordinates of the diagram are per-phase real volt-amperes and per-phase reactive volt-amperes. When expressed in kilovolts, the coordinates become thousands of kilowatts and thousands of reactive kilovolt-amperes. Total three-phase power is three times the per-phase power. All of the expressions for power written contain products of \bar{E}_s^2 , \bar{E}_R^2 , or $\bar{E}_s \bar{E}_R$. When given in terms of line-to-line voltages, they are all three times as great as when line-to-neutral voltages are used and thus the equations then represent total three-phase power.

Referring to Fig. 10 for the operating condition indicated by the given angle θ the point A of the power circle diagram shows the value of P_s and Q_s being delivered to the line at the sending end and the point B the value of P_R and Q_R drawn from the line at the receiving end. The difference between P_s and P_R is the $R\bar{I}^2$ loss of the line itself for this operating condition.

The value of Q at each end is the reactive power which must be supplied to the line in the case of the sending end or drawn from the line in the case of the receiving end in order to maintain the chosen terminal voltages. At the receiving end the reactive power drawn by the load itself at the particular load power factor may not be equal to that required to maintain the desired voltage. If a synchronous condenser is used at the receiving end, the difference must be supplied by the condenser to maintain the voltage.

It will be noted that for a given network and given voltages at both ends there is a definite limit to the amount of power which may be transmitted. If the angle θ is increased beyond this point, the amount of power transmitted is reduced. The critical value of θ for this condition was shown by Eq. 66 to be $\theta = \gamma$. The only way the power limit may be increased for a given network is by increasing the voltage at either or both ends. Increasing the voltage at one end increases the radius of both circles in direct proportion and moves the center at that end only away from the origin, along a line connecting the original center to the origin, proportional to the square of the voltage at that end. Where the network is subject to change, changes in network constants will also change the power limit. Referring to Fig. 10 and Eq. (66), it is evident that a decrease in the magnitude of Z will result in an increase in the power which may be transmitted. Thus any change which decreases the series impedance such as the addition of parallel circuits will increase the power limit.

Since the conjugate of the phase current, in amperes, is the per-phase power in volt-amperes at either end divided by the phase voltage at the same end, either the sending-end or receiving-end power circles, when placed in the proper quadrants, can be used to represent the locus of the current with a proper change in scale of the coordinates. Referring to the sending end circle diagram of Fig. 10, $P_s + jQ_s = E\bar{I}$ and for the point A, Q_s is positive lagging reactive power. Therefore the imaginary component of the conjugate of the current is positive; the imaginary component of the current is negative. If the power circle diagrams are rotated about the real power axis so that the center of the sending-end circle is in the fourth quadrant ($\frac{\bar{E}_s^2}{Z}$ will then be the vector to center), and the center of

the receiving end circle is in the second quadrant, then the power circle diagrams properly represent the current circle diagrams if the appropriate change in scale of the coordinates is made. Lagging reactive current is negative and leading reactive current is positive.

If the sending-end circle is used the current is referred to the sending end voltage as the reference vector and the coordinates should be divided by the sending end voltage. For instance, if the sending-end power diagram were constructed using line-to-line voltages in kilovolts resulting in power coordinates given in thousands of total three-phase kilovolt-amperes, the power coordinates should be divided by $\sqrt{3}$ times the line-to-line sending end voltage in kilovolts giving current coordinates in thousands of amperes. If the receiving end circle is used, the current is referred to the receiving end voltage as reference. For the current circle diagrams the angle θ still, of course, refers to the angle between the two terminal voltages.

For a study of the performance of a system it is sometimes found convenient to plot on the power circle diagram a family of circles corresponding to the various operating voltages. The most common case is one in which the line is to operate at a fixed receiver voltage and it is desired to determine the line performance for various sending-end voltages. For such a case the receiver diagram is usually all that is needed.

Example 4—An example of this type of problem is shown in Fig. 11. There the line constants are given to-

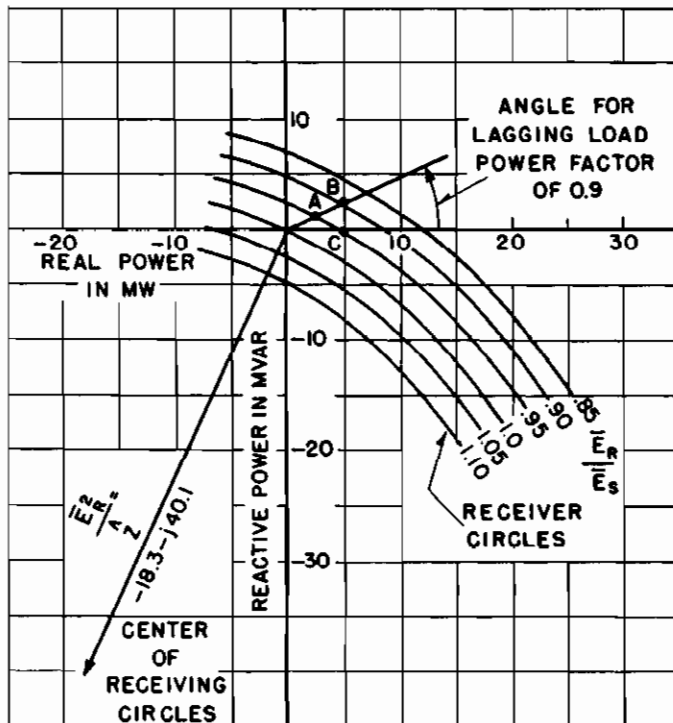

Fig. 11—Family of receiver power circles for a 15-mile line with No. 0000-19 strand-copper conductors and 4-foot equivalent spacing.

Receiver voltage $E_R = 22$ -kv line-to-line.
 $r = 0.303$ ohm per mile.
 $x = 0.665$ ohm per mile.
 $Z = zs = 10.94$ ohms.

gether with the quantities for laying out the diagram. Since the coordinate of the center of the power circles depends only on E_R which is fixed, all the circles have the same center but different radii corresponding to the different values of sending end voltages.

Examination of this figure shows, for example, that the maximum load at 0.9 power factor lag which can be carried by the line at 5 percent regulation without reactive power correction is that indicated by point A or about 2600 kw. If it is desired to transmit a load of 5000 kw indicated by point B, the regulation would be about 11 percent without rkva correction. To reduce the regulation for this load to 5 percent would require that the receiver and load conditions be that indicated by the point C, and it is evident that about 2400 lagging reactive kilovolt-amperes must be supplied to the receiver end of the line to attain this condition by having capacitors or a synchronous condenser supply that amount of lagging reactive kilovolt-amperes.

21. Current and Power Equations and Circle Diagrams for Long Lines

Representing long lines by their equivalent π circuit as shown in Fig. 6 results in modifying the form of the simple short line equivalent circuit by the addition of the shunt capacitive reactances at each end

$$Z'_{eq} = \bar{Z}'_{eq} \epsilon^{-j90^\circ} = -jX'_{eq}$$

Thus the equations for the terminal currents have an additional term as shown in Fig. 8.

$$I_s = \frac{E_s - E_R}{Z_{eq}} + \frac{E_s}{Z'_{eq}}; \quad \hat{I}_s = \frac{\hat{E}_s - \hat{E}_R}{\hat{Z}_{eq}} + \frac{\hat{E}_s}{\hat{Z}'_{eq}} \quad (67)$$

$$I_R = \frac{E_s - E_R}{Z_{eq}} - \frac{E_R}{Z'_{eq}}; \quad \hat{I}_R = \frac{\hat{E}_s - \hat{E}_R}{\hat{Z}_{eq}} - \frac{\hat{E}_R}{\hat{Z}'_{eq}} \quad (68)$$

The sending- and receiving-end power is determined in the same manner as for the short line.

$$P_s + jQ_s = E_s \hat{I}_s = \frac{\bar{E}_s^2}{\hat{Z}_{eq}} - \frac{E_s \bar{E}_R}{\hat{Z}_{eq}} + \frac{\bar{E}_s^2}{\hat{Z}'_{eq}} \quad (69)$$

Rewriting Eq. (69) in a slightly different form

$$P_s + jQ_s = \left(\frac{\bar{E}_s^2}{\hat{Z}_{eq}} + \frac{\bar{E}_s^2}{\hat{Z}'_{eq}} \right) - \frac{\bar{E}_s \bar{E}_R \epsilon^{j\theta}}{\hat{Z}_{eq}} \quad (70)$$

Similarly for receiving end power:

$$P_R + jQ_R = \left(-\frac{\bar{E}_R^2}{\hat{Z}_{eq}} - \frac{\bar{E}_R^2}{\hat{Z}'_{eq}} \right) + \frac{\bar{E}_R \bar{E}_s \epsilon^{-j\theta}}{\hat{Z}_{eq}} \quad (71)$$

A comparison of Eq. (70) with (64), and (71) with (65) shows them to be of the same form consisting of a fixed vector with a second vector constant in magnitude but variable in phase, added to it. The power circle diagram can be plotted as shown in Fig. 12. The circle diagram is most easily obtained by the numerical and vector substitution for the voltages and impedances. The center and the radius of the circle can then be calculated by reduction using a combination of polar and Cartesian coordinates. Example 5 illustrates the method and shows the power circle diagrams which are obtained in Fig. 13.

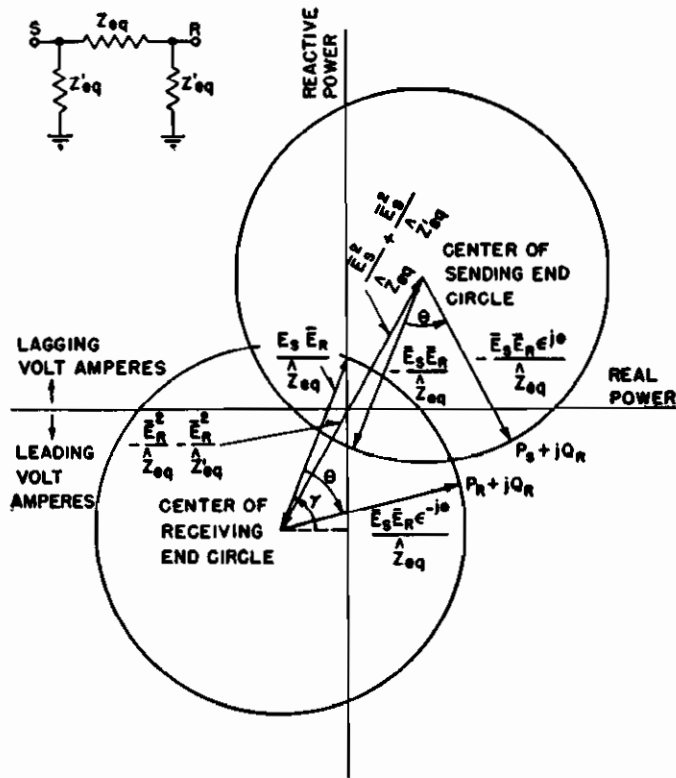

Fig. 12—Power circle diagram for long lines.

In Eqs. (70) and (71) the terms

$$\frac{\bar{E}_S^2}{Z_{eq}} \text{ and } -\frac{\bar{E}_R^2}{Z'_{eq}}$$

are not a function of the angle θ and therefore add directly to the "short line" fixed vector so that the effect is to shift the center of the power circles in the direction of volt-amperes only. The presence of the shunt reactances decreases the amount of positive reactive volt-amperes put into the sending end of the line for a given amount of real power and increases the positive volt-amperes delivered at the receiving end. This decreases the amount of leading reactive volt-amperes which would have to be absorbed by synchronous condensers or capacitors for a given load condition. It does not affect the real power conditions for a given operating angle or the load limit of the line. These factors are determined entirely by the series impedance of the line.

Referring to Fig. 12, if the radius of the receiving-end circle for $\theta=0$ were plotted with the origin as the center, the vector would be at an angle γ with the real power axis. The angle indicated on Fig. 12 is therefore equal to γ , the angle of the equivalent series impedance. The maximum real power that can be delivered over the line occurs when $\theta = \gamma$.

The current circle diagrams for the sending- and receiving-end currents can be obtained as discussed in Sec. 20. The sending-end current diagram is obtained from the sending-end power circle and is referred to the sending-end voltage vector as reference. The receiving-end current diagram is obtained from the receiving-end power circle and is referred to the receiving-end voltage.

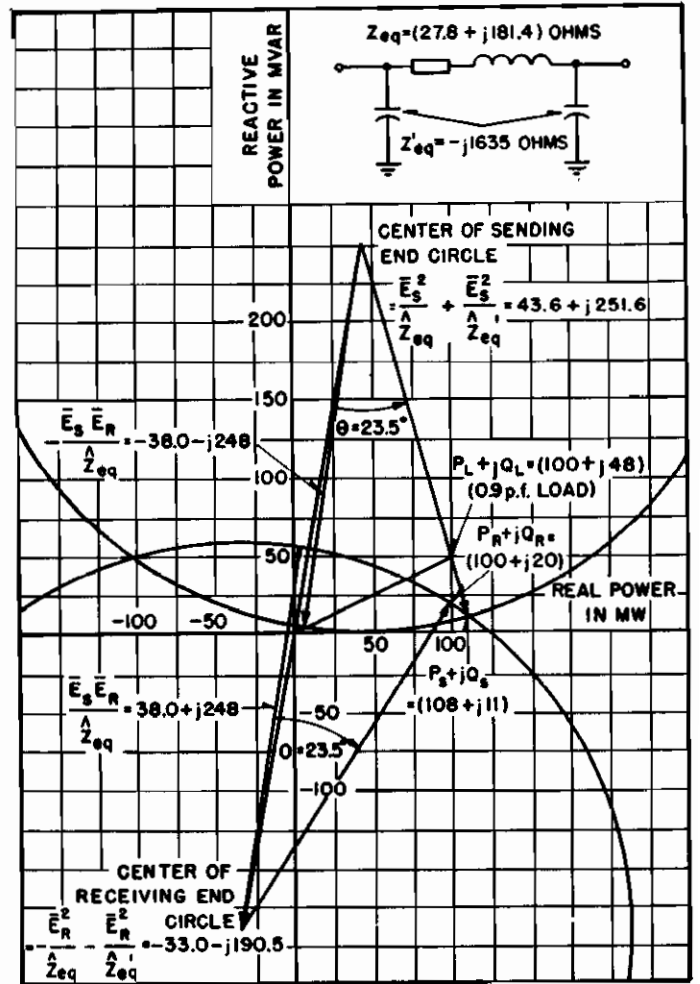

Fig. 13—Equivalent circuit and power circle diagram for a 230-mile line with 500 000 circular mil. stranded copper conductors and an equivalent spacing of 22 feet.

Operating voltages; $E_S = 230$ -kv, $E_R = 200$ -kv, line-to-line.

For this line $r = 0.130$ ohms per mile.

$x = 0.818$ ohms per mile.

$x' = 0.1917$ megohms per mile.

From curves of Fig. 6 for 230 miles

$K_r = 0.931$

$K_x = 0.964$

$k_r = 0.982$

$Z_{eq} = (27.8 + j181.4)$ ohms; $Z'_{eq} = -j1635$ ohms.

Example 5—Fig. 13 shows the power circle diagram constructed for an actual line.

The power circle diagrams are obtained from Eqs. (70) and (71). If line-to-neutral voltages in kv are used, the results must be multiplied by three to obtain real and reactive power in mw and mvar. If the line-to-line voltages in kv are used, the results are three-phase power in mw and mvar.

$$\begin{aligned} \text{Vector to center} &= \frac{\bar{E}_S^2}{Z_{eq}} + \frac{\bar{E}_R^2}{Z'_{eq}} \\ &= \frac{(230)^2}{27.8 - j181.4} + \frac{(230)^2}{+j1635} \\ &= \frac{(230)^2}{183.4 e^{-j81.28^\circ}} + \frac{(230)^2}{1635 e^{j90^\circ}} \end{aligned}$$

$$= 288 e^{j81.28^\circ} + 32.4 e^{-j90^\circ}$$

$$= 43.6 + j284 - j32.4 = 43.6 + j251.6$$

Radius of the sending end circle = $-\frac{\bar{E}_s \bar{E}_R \epsilon^{j\theta}}{\hat{Z}_{eq}}$ for $\theta = 0$.

$$= -\frac{230 \times 200}{27.8 - j181.4} = -251 e^{j81.28^\circ} = -38.0 - j248$$

$$P_s + jQ_s \text{ (for } \theta = 0) = 43.6 + j251.6 - 38.0 - j248 = 5.6 + j3.6$$

Similarly for the receiving circle:

Vector to center = $-\frac{\bar{E}_R^2}{\hat{Z}_{eq}} - \frac{\bar{E}_R^2}{\hat{Z}'_{eq}}$

$$= -\frac{(200)^2}{27.8 - j181.4} - \frac{(200)^2}{j1635} = -33.0 - j190.5$$

for $\theta = 0$, Radius = $\frac{\bar{E}_s \bar{E}_R}{\hat{Z}_{eq}} = 38.0 + j248$

and $P_R + jQ_R = -33.0 - j190.5 + 38.0 + j248 = 5.0 + j57.5$

Figure 13 shows the power circle diagrams plotted from the calculated results given above. Suppose it is desired to deliver a load of 100 mw at 0.9 power factor lagging; i.e., $P + jQ = 100 + j48$. From the curves of Fig. 13, for a delivered power of 100 mw the angle θ is 23.5° . The following values from the circle diagrams are $P_s + jQ_s = 108 + j11$ and $P_R + jQ_R = 100 + j20$. These values are indicated on the diagram of Fig. 14. The arrow indicates the direc-

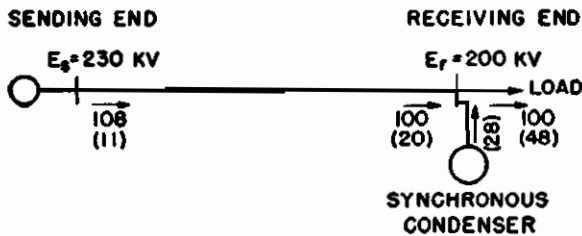

Fig. 14—Recorded values of power flow as obtained from Fig. 13 and Example 5.

tion of positive real power flow. Inductive lagging reactive power in the same direction is positive and is the value in parenthesis. These designations and nomenclature follow present-day network calculator practice.

At the receiving end there is a deficit of lagging reactive power. A synchronous condenser operating overexcited would be required to supply 28 mvar. If the condenser is considered as a load the direction of the arrow can be reversed with a minus sign in front of the value for the reactive power. The synchronous condenser is then taking negative, or leading reactive power.

22. Current and Power Equations and Circle Diagrams for the General Equivalent π Circuit

The circle diagrams are applicable to the study of the performance of an overall system. Such a system can be represented by an equivalent π circuit of the form shown in Fig. 15. For such a case the shunt impedances usually are not equal and have resistance components introduced by the presence of other equipment containing resistance.

If the shunt impedances take the completely general form of Z'_s and Z'_R , the equations for sending- and re-

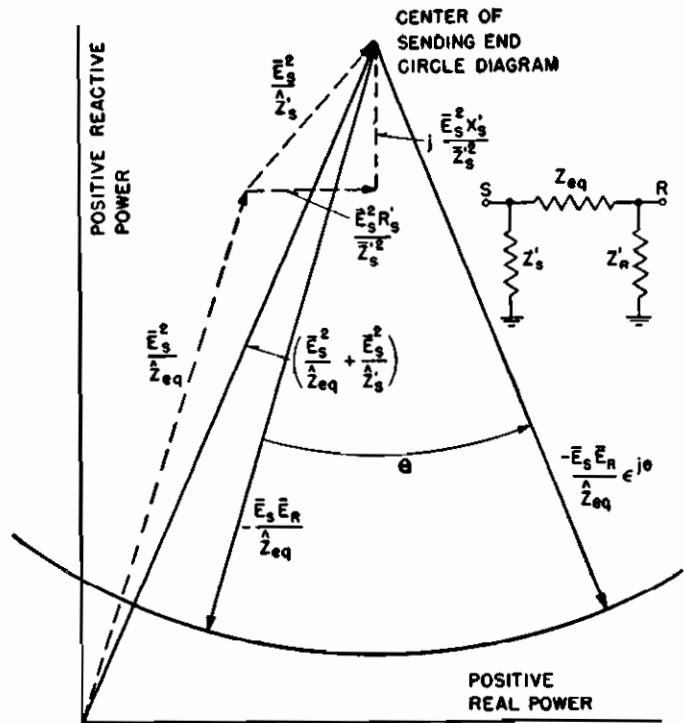

Fig. 15—Power circle diagram for the general equivalent π circuit.

ceiving-end power can be written directly from equations (70) and (71).

$$P_s + jQ_s = \left(\frac{\bar{E}_s^2}{\hat{Z}_{eq}} + \frac{\bar{E}_s^2}{\hat{Z}'_s} \right) - \frac{\bar{E}_s \bar{E}_R \epsilon^{j\theta}}{\hat{Z}_{eq}} \quad (72)$$

and
$$P_R + jQ_R = \left(-\frac{\bar{E}_R^2}{\hat{Z}_{eq}} - \frac{\bar{E}_R^2}{\hat{Z}'_R} \right) + \frac{\bar{E}_s \bar{E}_R \epsilon^{-j\theta}}{\hat{Z}_{eq}} \quad (73)$$

The construction of the power circle diagrams is the same as for the long lines as shown in Fig. 12. In the case of the general equivalent π , Z_s replaces Z_{eq}' at the sending end and Z'_R replaces Z_{eq}' at the receiving end. The effect of resistance and reactance in the shunt branch at the sending or the receiving end can be visualized better if the impedance is expressed in Cartesian coordinate form. Referring to Eq. (72), the second quantity in the first term becomes

$$\frac{\bar{E}_s^2}{\hat{Z}'_s} = \frac{\bar{E}_s^2}{R'_s - jX'_s} = \frac{\bar{E}_s^2 R'_s}{Z_s'^2} + j \frac{\bar{E}_s^2 X'_s}{Z_s'^2} \quad (74)$$

This quantity is added to the "short line" vector to center,

$$\frac{\bar{E}_s^2}{\hat{Z}_{eq}}$$

This point as applied to the sending end circle diagram is illustrated in Fig. 15. The complete vector to center is shown as $\frac{\bar{E}_s^2}{\hat{Z}_{eq}} + \frac{\bar{E}_s^2}{\hat{Z}'_s}$, as the sum of the two individual vector

quantities, and as the sum of the vector $\frac{\bar{E}_s^2}{\hat{Z}_{eq}}$ and the Cartesian coordinates $\frac{\bar{E}_s^2 R'_s}{Z_s'^2}$ and $j \frac{\bar{E}_s^2 X'_s}{Z_s'^2}$.

Referring to Fig. 15 and Eq. (74) the effect of resistance is to shift the center of the circle in the direction of increased positive real power. A positive reactance shifts the center in the direction of increased positive reactive power; a negative reactance shifts the center in the direction of decreased positive reactive power.

In the case of the receiving-end circle diagram, the effect of resistance is to shift the center of the circle in the direction of increased negative real power. A positive reactance shifts the center in the direction of increased negative reactive power; a negative reactance shifts the center in the direction of decreased negative reactive power.

The current circle diagrams for this case can be determined as discussed in Secs. 20 and 21.

23. Loss Diagram

Although the resistance loss can be taken from the power circle diagram, it can be obtained more accurately and conveniently from the Loss Diagram.

$$\text{Loss} = P_S - P_R$$

For the case where the transmission line alone is being considered

$$\begin{aligned} \text{Loss} &= \frac{\bar{E}_S^2}{Z^2} R - \frac{\bar{E}_S \bar{E}_R}{Z^2} (R \cos \theta - X \sin \theta) \\ &+ \frac{\bar{E}_R^2}{Z^2} R - \frac{\bar{E}_S \bar{E}_R}{Z^2} (R \cos \theta + X \sin \theta) \\ &= (\bar{E}_S^2 + \bar{E}_R^2) \frac{R}{Z^2} - 2 \frac{\bar{E}_S \bar{E}_R}{Z^2} R \cos \theta \end{aligned} \quad (75)$$

The graphical representation of this equation is given in Fig. 16.

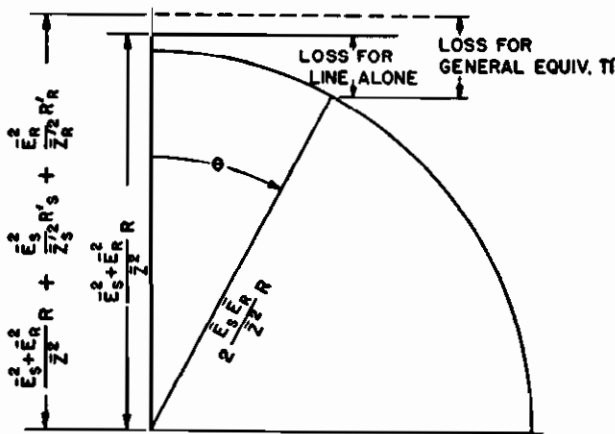

Fig. 16—The transmission line loss diagram (when solving for general equivalent π loss, substitute R_{eq} for R and \bar{Z}_{eq} for \bar{Z}).

For the general equivalent π circuit, the equation for loss is

$$\begin{aligned} \text{Loss} &= \left[\bar{E}_S^2 + \bar{E}_R^2 \right] \frac{R_{eq}}{\bar{Z}_{eq}^2} + \frac{\bar{E}_S^2}{(\bar{Z}'_S)^2} R'_S \\ &+ \frac{\bar{E}_R^2}{(\bar{Z}'_R)^2} R'_R - 2 \frac{\bar{E}_S \bar{E}_R}{\bar{Z}_{eq}^2} R_{eq} \cos \theta \end{aligned} \quad (76)$$

As shown by Fig. 16 this is equivalent to the formula for the loss on the transmission line alone except for the terms $\frac{\bar{E}_S^2}{(\bar{Z}'_S)^2} R'_S$ and $\frac{\bar{E}_R^2}{(\bar{Z}'_R)^2} R'_R$ which represent the losses in the resistance components of the shunt impedances Z'_S and Z'_R .

As was the case for the previous power equations, if line-to-neutral voltages are used, the loss is on a per phase basis; and if line-to-line voltages are used the total three-phase loss is represented.

An equation for the load which can be delivered at a given percent line loss on lines regulated by synchronous capacity is important in determining their performance. Upon the assumption of equal sending- and receiving-end voltages a very simple approximate equation can be derived which gives an accuracy of a fraction of a percent over the practical operating range of loss and regulation. When loss is expressed as a percentage of P_{R1} this equation is:

$$P_R = \frac{\% \text{ Loss}}{(100 + \% \text{ Loss})} \left[\frac{\bar{E}_R^2 X_{eq}^2}{R_{eq} \bar{Z}_{eq}^2} \right] \quad (77)$$

A corresponding equation for Q_R is

$$Q_R = \bar{E}_R^2 \left[\frac{X_{eq}}{\bar{Z}_{eq}^2} \left(1 + \frac{\% \text{ Loss}}{100} \right) - \frac{1}{X'_{eq}} \right] \quad (78)$$

P_R in Eq. (77) is, of course, independent of the load power factor and from Eq. (78) the required amount of synchronous capacity to maintain equal sending- and receiving-end voltages for the delivered load P_R can be obtained by subtracting the reactive kva of the load from Q_R .

24. Current and Power Relations in Terms of the ABCD Constants

In many cases it is desirable to use $ABCD^*$ constants because of the desirability of the check $AD - BC = 1$. This is particularly true where there are several combinations of circuits including transmission lines, series impedances and shunt impedances. Expressions for sending and receiving end power can be obtained readily and the circle diagrams can be drawn.

$$E_S = A E_R + B I_R \quad (79)$$

$$I_S = C E_R + D I_R \quad (80)$$

$$E_R = D E_S - B I_S \quad (81)$$

$$I_R = -C E_S + A I_S \quad (82)$$

Solution of the above equations for I_S and I_R gives:

$$I_S = \frac{D}{B} E_S - \frac{E_R}{B}; \quad \hat{I}_S = \frac{\hat{D}}{\hat{B}} \hat{E}_S - \frac{\hat{E}_R}{\hat{B}} \quad (83)$$

$$I_R = \frac{E_S}{B} - \frac{A}{B} E_R; \quad \hat{I}_R = \frac{\hat{E}_S}{\hat{B}} - \frac{\hat{A}}{\hat{B}} \hat{E}_R \quad (84)$$

$$\begin{aligned} P_S + jQ_S &= E_S \hat{I}_S \\ &= E_S \hat{E}_S \frac{\hat{D}}{\hat{B}} - \frac{E_S \hat{E}_R}{\hat{B}} \\ &= \bar{E}_S^2 \frac{\hat{D}}{\hat{B}} - \frac{\bar{E}_S \bar{E}_R \epsilon^{j\theta}}{\hat{B}} \end{aligned} \quad (85)$$

*For definition of $ABCD$ constants see Chap. 10 Sec. 21.

TABLE 3. TYPICAL TRANSMISSION LINE CHARACTERISTICS AT 60 CYCLES

Circuit Voltage Kv L-L	Conductor Size Thousands of Cir. Mils or AWG	Tower Construction*	Equiv. Spacing Feet	Resistance at 50°C Ohms Per Phase Per Mile	Reactance Per Phase Per Mile		Shunt-Capacitive Reactance Megohms Per Phase Per Mile	Three Phase Charging Kva Per Mile	Surge Impedance Ohms I-N	Surge-Impedance Loading (SIL) in Three Phase Kw
					Ohms	% on 100 Mva, Three Phase Base				
69	2/0 Cu	SC-W**	8	0.481	0.7843	1.64	0.1822	26.1	378	12 600
69	336.4 ACSR	DC-ST	11	0.306	0.7420	1.55	0.1750	27.2	360	13 200
69	4/0 Cu	SC-W	14	0.303	0.8112	1.70	0.1902	25.0	393	12 100
69	336.4 ACSR	SC-W	14	0.306	0.7712	1.61	0.1822	26.1	375	12 700
69	336.4 ACSR	SC-ST	19	0.306	0.8083	1.69	0.1913	24.9	393	12 100
115	336.4 ACSR	DC-ST	13	0.306	0.7622	0.576	0.1800	74.7	370	35 700
115	4/0 Cu	SC-W	17	0.303	0.8348	0.631	0.1960	67.5	404	32 700
115	336.4 ACSR	SC-W	17	0.306	0.7948	0.601	0.1880	70.4	386	34 200
115	336.4 ACSR	SC-ST	22	0.306	0.8261	0.624	0.1956	67.6	402	32 800
138	397.5 ACSR	DC-ST	15	0.259	0.7636	0.401	0.1809	105.	371	51 200
138	250 Cu	SC-W	18	0.257	0.8317	0.436	0.1952	97.6	404	47 100
138	397.5 ACSR	SC-W	18	0.259	0.7857	0.412	0.1864	102.	382	49 800
138	397.5 ACSR	SC-ST	24	0.259	0.8206	0.430	0.1949	97.7	399	47 600
161	397.5 ACSR	DC-ST	17	0.259	0.7788	0.300	0.1847	140.	379	68 400
161	250 Cu	SC-W	19	0.257	0.8383	0.323	0.1968	132.	406	63 800
161	397.5 ACSR	SC-W	19	0.259	0.7923	0.305	0.1880	138.	386	67 200
161	397.5 ACSR	SC-ST	25	0.259	0.8256	0.318	0.1961	132.	402	64 400
230	795 ACSR	DC-ST	22	0.1288	0.7681	0.145	0.1821	291.	374	141 000
230	500 HH-Cu	SC-W	25	0.1260	0.7436	0.140	0.1800	294.	365	145 000
230	795 ACSR	SC-W	25	0.1288	0.7836	0.148	0.1859	285.	381	139 000
230	795 ACSR	SC-ST	31	0.1288	0.8097	0.153	0.1923	275.	394	134 000
Avg. 0.7911					Avg. 0.1878			Avg. 386		

*DC-ST—double circuit—steel tower
 SC-W —single circuit —wood
 SC-ST —single circuit —steel tower

**Two-crossarm construction forming triangular configuration.
 All other SC-W are H frame construction.

rules are given for estimating charging kva in the following discussion.

The surge impedance of a transmission line is numerically equal to $\sqrt{\frac{L}{C}}$. It is a function of the line inductance and capacitance as shown and independent of line length. A convenient average value of surge impedance is 400 ohms. As shown in the table, this value is more representative of the larger stranded copper conductors than it is for the ACSR conductors. Compared to the average value of 386 ohms from the table, 400 ohms is a good approximation.

Surge-impedance loading in mw is equal to

$$\frac{(kv_{L-L})^2}{\text{Surge Impedance}}$$

and can be defined as the unit power factor load that can be delivered over a resistanceless line such that the $\bar{I}^2 X$ is equal to the charging kva of the line. Under this condition the sending-end and receiving-end voltages and currents are equal in magnitude but different in phase position. In the practical case of a line having resistance, the magnitude of the sending-end voltage is approximately equal to the magnitude of the receiving-end voltage plus the product of the magnitude of the current and the line

resistance; i.e., $\bar{E}_s = \bar{E}_r + \bar{I}R$. Surge-impedance loading in itself is not a measure of maximum power that can be delivered over a line. Maximum delivered power must take into consideration the length of line involved, the impedance of sending- and receiving-end equipment, and in general all of the major factors that must be considered with regard to stability. The relation of surge-impedance loading to line length, taking into account the stability consideration, is covered in Chap. 13, Part IX.

Following is a summary of approximations that may be applied to transmission lines for estimating purposes:

1. Series reactance of a line = 0.8 ohm per mile.
2. Shunt-capacitive reactance of a line = 0.2 megohm per mile.
3. Surge impedance of a line = 400 ohms.
4. Surge-impedance loading, (SIL) in mw = $\frac{(kv_{L-L})^2}{400}$ or in kw = $2.5(kv_{L-L})^2$.
5. (a) Charging kva for a hundred miles of line is 20.5 percent of the SIL.
 (b) Charging kva of a line is also = $5000\left(\frac{L}{100}\right)\left(\frac{kv_{L-L}}{100}\right)^2$,

where L = line length in miles,
 kv_{L-L} = line-to-line voltage in kilovolts.

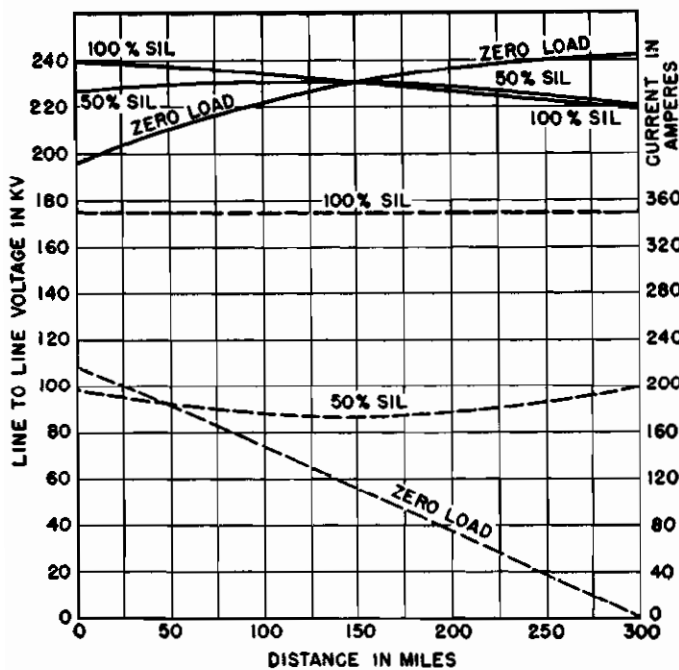

Fig. 18—Distribution of voltage and current along a 300-mile transmission line, 795 000 circular mils, ACSR conductor, 25-foot equivalent spacing.

— Voltage
 - - - - - Current
 $r = 0.117$ ohm per mile
 $x = 0.7836$ ohm per mile
 $x' = 0.1859$ megohm per mile

The effect of the distributed capacitance of a transmission line on the voltage and current distribution along the line is illustrated in Fig. 18. The calculated results are based on a transmission line 300 miles in length, 230 kv, 795 000 circular mils, and 25-foot equivalent spacing. The 100-percent surge-impedance loading of the line is 139 000 kilowatts. The current corresponding to this load at 100 percent voltage is 348 amperes. The voltage and current are shown as a function of the line length for 100 percent, 50 percent surge-impedance loading at the middle of the line and for zero delivered load. The voltage at the middle of the line was maintained at 230 kv and E_S and E_R were allowed to vary depending upon the load condition.

At 100-percent surge-impedance loading, the voltages $E_S = 240$ kv and $E_R = 219$ kv. The current is a constant value of 348 amperes. If the surge-impedance loading is assumed at the receiving end of the line, the magnitude of the current is slightly different at the sending end because of line resistance. The amount of this difference depends upon the ratio of line reactance to resistance and the length of the line. Based on the calculated voltages of E_S and E_R , the regulation of the line is 9.5 percent. The value of regulation as determined from the product of the magnitude of the current and the resistance is also 9.5 percent.

For 50-percent surge-impedance loading the current is a minimum value at the middle of the line. If the surge-impedance loading is taken at the receiving end, the current decreases to a minimum at the receiving end. In Fig. 18 surge-impedance loading is taken in the middle of the line

for purposes of exposition. Generally the surge-impedance loading should be considered at the receiving end because the delivered load is usually the quantity of most interest.

V. 60-CYCLE TRANSMISSION LINE REGULATION AND LOSS CHARTS

The voltage regulation and efficiency of a transmission line or distribution feeder are fundamental properties of its performance. In determining these quantities for existing systems or in designing new systems to meet given load requirements, it is thought that the charts presented here will save a great deal of time and labor that would in many cases be necessary if analytical methods were used.

For low voltage lines without synchronous or static capacitors, voltage regulation is usually the more important consideration. For instance, in the design of a line to carry a certain load one wishes to determine the proper transmission voltage and conductor size. Based on an assumed allowable regulation several voltages and conductor sizes will be found to transmit the load, the final choice being based upon economics for which the line efficiency is desired. The performance of higher voltage regulated lines, however, is determined primarily by the line loss.

The charts presented here were developed with these two points of view in mind. Quite frequently it is desired to obtain quickly an approximate solution. The Quick Estimating Charts afford a simple method for such cases. For more accurate calculations the Regulation and Loss Chart is provided. It is important to be able to consider more than just the line itself. The transformers are often the determining factor in the choice of the proper line voltage. The Regulation and Loss Chart is constructed so that from the knowledge of the equivalent impedance of a system its performance can be determined.

25. Quick Estimating Charts

In Figs. 19 and 20 are plotted curves showing the power which can be transmitted at five percent regulation together with the corresponding percent line loss for various voltages and conductor sizes. These curves afford the rapid estimation of such problems as the regulation for a known load, the load limit of a line for a given regulation and the determination of voltage and conductor size for the transmission of a given load at a given regulation. Fig. 21 is an aid for interpolation between the values of power factor given on the curves.

The curves of Fig. 22 give the power which can be transmitted for various conductors and voltages at a line loss of five percent. These curves are most useful in determining the performance of lines regulated by synchronous or static capacitors.

Charts Based Upon Regulation—Fig. 19 applies specifically to stranded copper conductors, but it can be used for copperweld-copper conductors with an accuracy of two to three percent. Fig. 20 applies to ACSR conductors. The load which can be transmitted over a line at a fixed regulation varies inversely with its length so that for a given line the actual load is the value read from the curves divided by the line length. For 220 to 440-volt lines the values on the curves are given in kilowatts times hun-

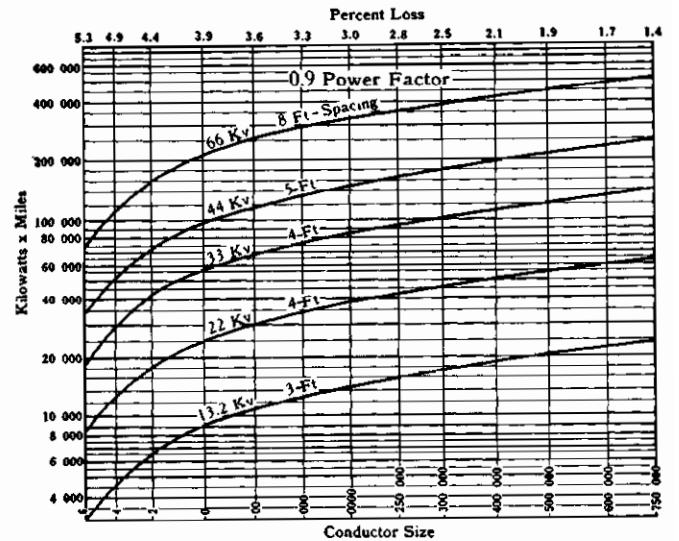
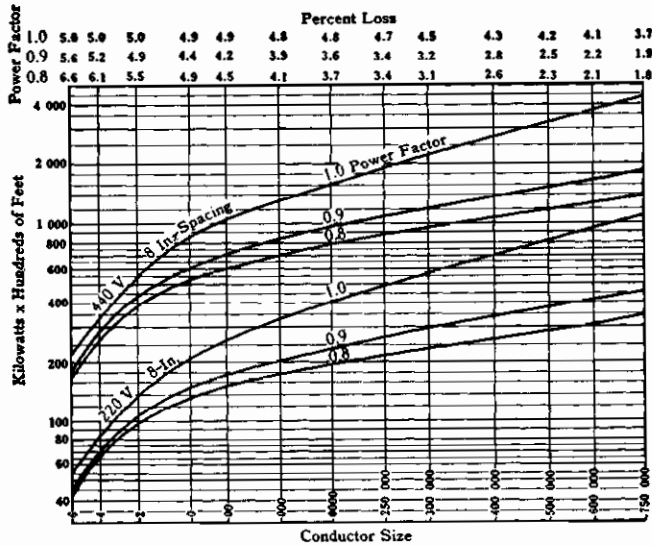
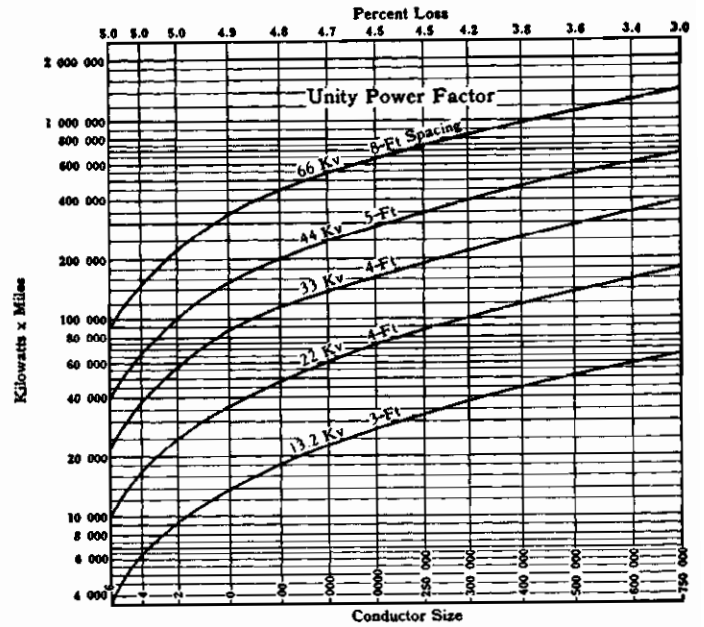
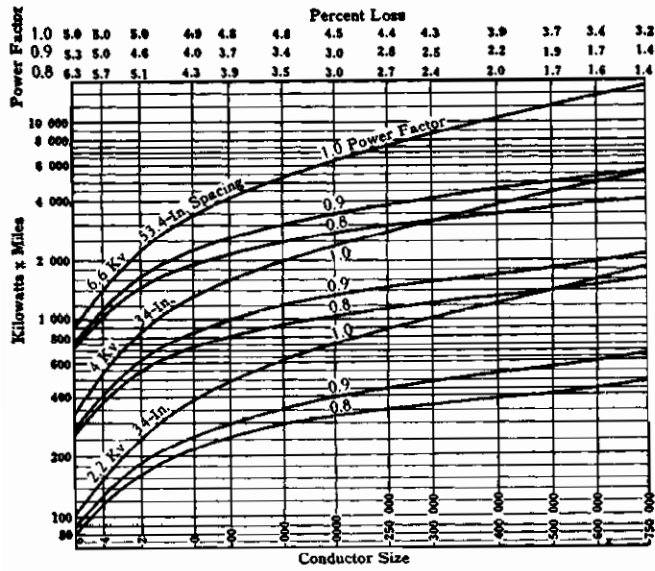

Fig. 19—Quick Estimating Charts Based Upon 5 Percent Regulation—Stranded Copper Conductors.

The curves give load in kilowatts × miles or kilowatts × hundreds of feet which can be received at 5 percent regulation together with corresponding line loss.

For a given length of line, power is equal to value read from curves divided by length of line.

Power for other regulations is approximately equal to values read from curves multiplied by $\frac{\% \text{ Reg}}{5}$.

For power factors other than given in charts, multiply values read from curves for unity power factor by fractions given in Fig. 21.

Percent loss for other regulations and power factors than found on charts are given by equation

$$(\text{Percent Loss})_2 = (\text{Percent Loss})_1 \times \frac{(\text{Kw Load})_2}{(\text{Kw Load})_1} \times \frac{(\text{Power Factor})_1^2}{(\text{Power Factor})_2^2}$$

For single phase lines divide power read from charts by 2 and percent loss by $\sqrt{3}$.

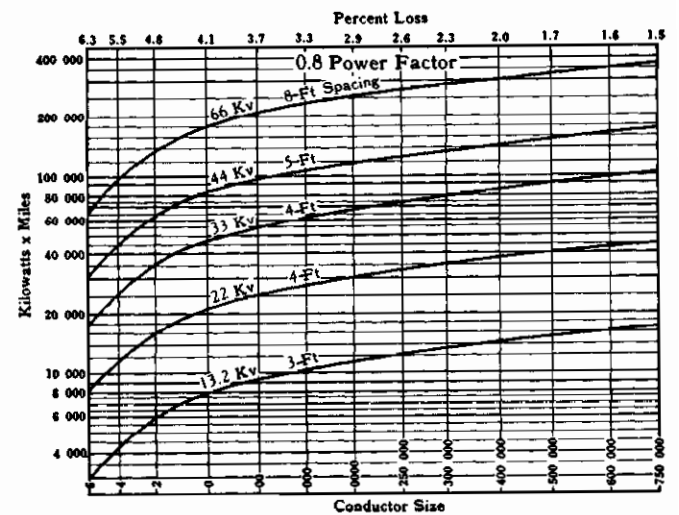

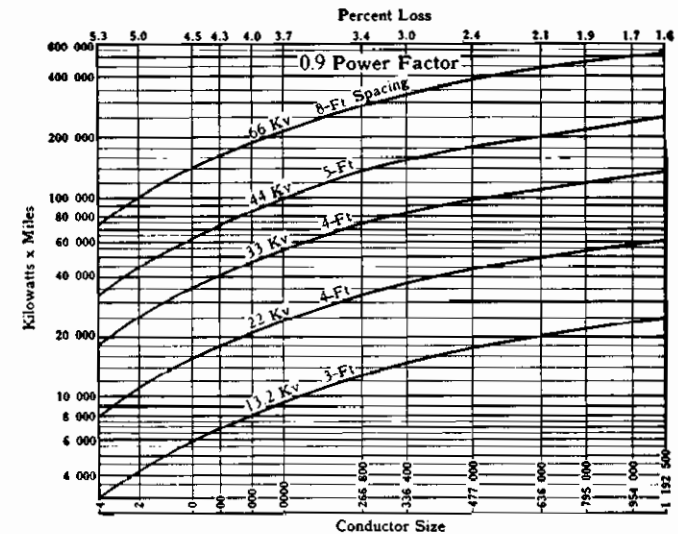
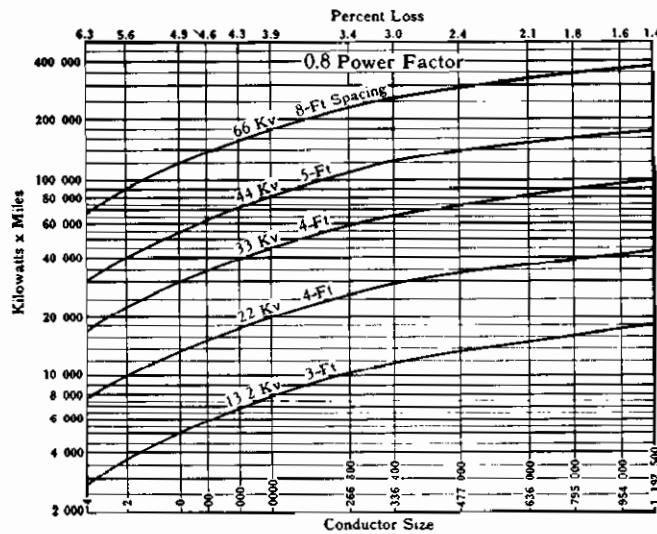
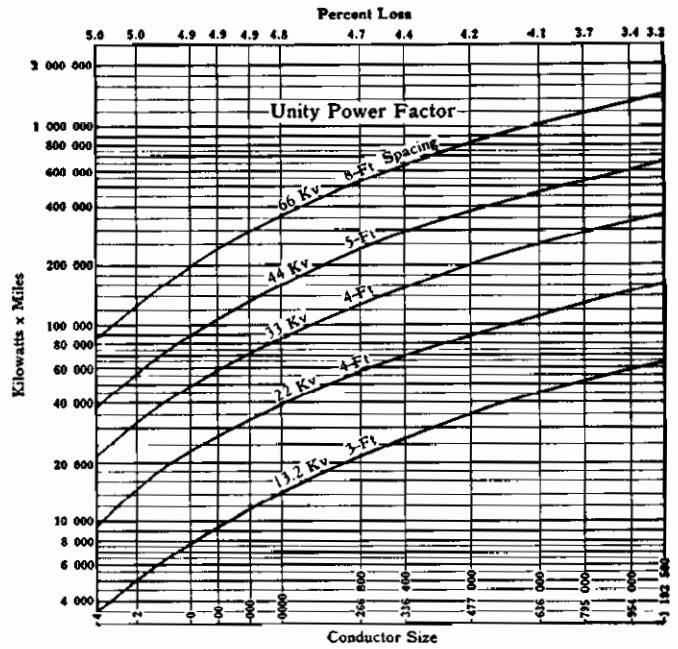
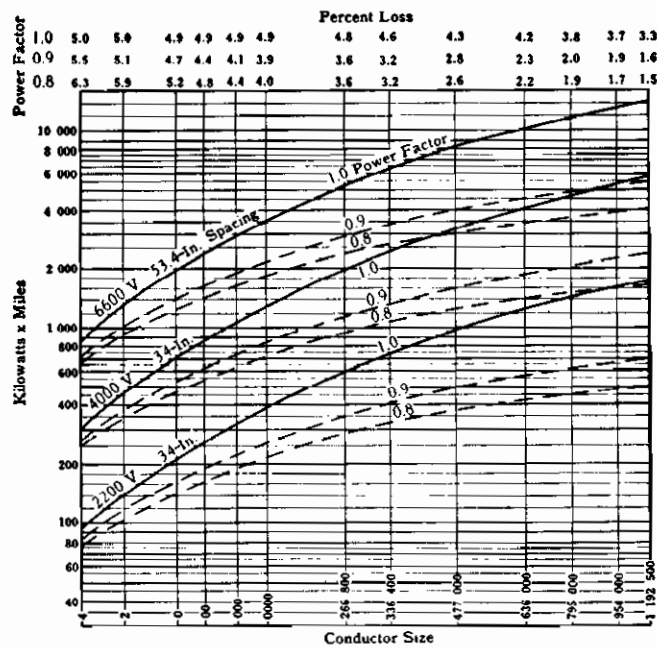

Fig. 20—Quick Estimating Charts Based Upon 5 Percent Regulation—A.C.S.R. Conductors.

The curves give load in kilowatt × miles which can be received at 5 percent regulation together with corresponding line loss.

For a given length of line, power is equal to value read from curves divided by length of line.

Power for other regulations is approximately equal to values read from curves multiplied by $\frac{\% \text{ Reg}}{5}$.

For power factors other than given in charts, multiply values read from curves for unity power factor by fractions given in Fig. 21.

Percent loss for other regulations and power factors than found on charts are given by equation

$$(\text{Percent Loss})_2 = (\text{Percent Loss})_1 \times \frac{(\text{Kw Load})_2}{(\text{Kw Load})_1} \times \frac{(\text{Power Factor})_1^2}{(\text{Power Factor})_2^2}$$

For single phase lines divide power read from charts by 2 and percent loss by $\sqrt{3}$.

dreds of feet. For higher voltages they are in kilowatts times miles.

For each voltage a common equivalent conductor spacing is assumed and the curves are drawn so that it is possible to interpolate to a good degree of accuracy for other voltages than those given. In addition the relationship that the power is proportional to the square of the voltage may be used. Since the percent loss does not vary more than about a tenth of one percent for each conductor size in each set of curves, mean values are given as shown.

For the same line voltage, conductor, equivalent spacing, and regulation half as much load can be transmitted on a single-phase two-wire line as for a three-phase line. For this reason the curves can be used to good accuracy for this kind of line by simply dividing by two the load read from them. For this single-phase load the percent

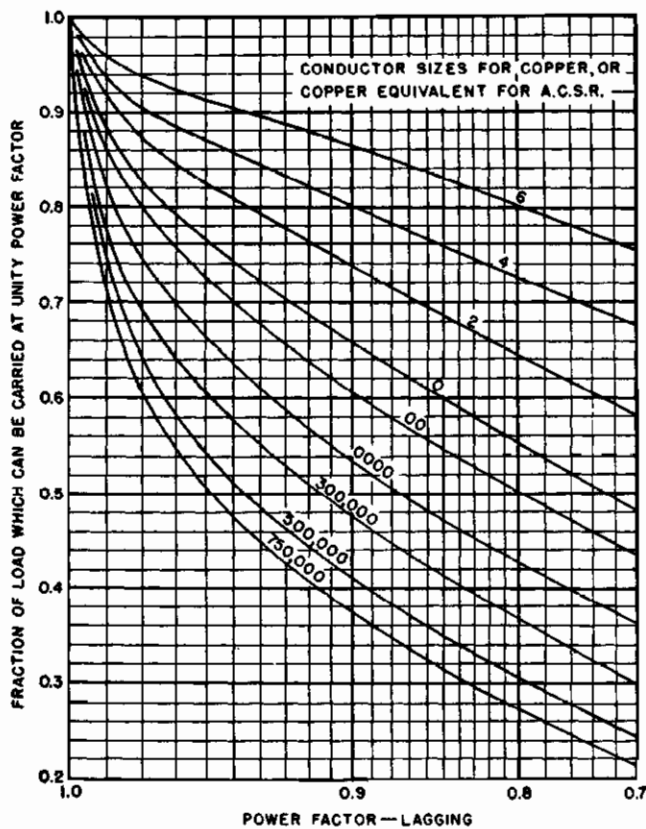

Fig. 21—Effect of power factor on load that can be carried at a fixed regulation.

Curves apply specifically for three foot equivalent spacing and five percent regulation, but can be used with good accuracy for normal spacing and regulation range.

loss will be that read from the charts divided by $[\sqrt{3}$ (or 1.732)].

Curves are presented for three common power factors: unity, 0.9 lag, and 0.8 lag. It is difficult to interpolate for other power factors, however, especially between unity and 0.9. To facilitate this the curves of Fig. 21 are provided showing the effect of power factor on the load that can be transmitted at a fixed regulation in terms of that at unity power factor. The curves apply specifically to stranded copper conductors at a three foot equivalent spacing and for five percent regulation, but they will give an accuracy within 10 percent for conductor spacings up to 20 feet and for the same copper equivalent in other common conductors. The error however may be as high as 25 percent for spacings as small as 8 inches.

The Quick Estimating Curves can also be used for other values of regulation if the approximation is made that the load which can be transmitted varies directly with the regulation.

After having determined the load for other power factors or regulations than those for which the curves are drawn, the percent loss can be determined from the relation

$$\begin{aligned} (\text{Percent Loss})_2 &= (\text{Percent Loss})_1 \\ &\times \frac{(\text{Kw Load})_2}{(\text{Kw Load})_1} \times \frac{(\text{Power Factor})_1^2}{(\text{Power Factor})_2^2} \end{aligned} \quad (88)$$

Charts Based Upon Loss—In Fig. 22 (a) are plotted curves for short lines which show the power in kilowatts times miles which can be transmitted under two conditions. The solid curves are based on five percent loss and equal receiving- and sending-end voltages. These are useful for lines where little regulation can be allowed such as on interconnected systems. The dotted curves are for the maximum power which can be transmitted at the given load voltage and five percent loss. For this condition the regulation varies but in no case does it exceed about five percent.

Fig. 22 (b) is for higher voltage lines long enough that distributed capacitance of the line need be considered. Only the condition of equal sending and receiving end voltages is considered here since regulation does not greatly effect the power for the conductors and spacings practical to use. For all of these curves an arbitrary coordinate system has been used for the abscissa beneath which is plotted the correct sizes for the various conductors. The curves here are based on 10 percent loss.

Equation (77) was used for determining the curves for equal voltages at both ends of the line and its examination shows that, for the practical range of losses, power for other values of percent loss are very nearly that read from the curves multiplied by $\frac{\% \text{ Loss}}{5 \text{ or } 10}$. If greater accuracy is

desired the factor $\frac{\% \text{ Loss}}{100 + \% \text{ Loss}}$ of Eq. (77) can be used.

Eq. (55) was used for the curves based on the maximum power at five percent loss. For this case power is directly proportional to loss. For both sets of curves it is proportional to the square of the receiving-end voltage.

The power which can be transmitted over a single-phase line is one half that of a three-phase line of the same equivalent spacing and line-to-line voltage. Thus Fig. 22(a) can be used to good accuracy for single-phase lines by dividing the values read from the curves by two.

26. Examples of the Use of the Quick Estimating Charts

Example 6(a)—Determine the maximum load at unity power factor and five percent regulation which can be transmitted over a three-phase five-mile line having 300 000 cir mil stranded copper conductors and operating at a load line voltage of 22 kv.

From the unity power factor curves of Fig. 19 for this conductor size and voltage, 100 000 kw times miles is obtained. The load is then $\frac{100\,000}{5} = 20\,000$ kilowatts. The percent loss read from the curves is 4.2.

Example 6(b)—What is the load for this line at this regulation but 0.95 power factor lag? Referring to Fig. 21 it is seen that for this conductor size 0.58 as much load can be transmitted at 0.95 power factor as at unity.

Thus the load is $20\,000 \times .58 = 11\,600$ kilowatts. The percent loss as determined from Eq. (88) is

$$\text{Percent Loss} = (4.2) \frac{11\,600(1)^2}{20\,000(.95)^2} = 2.7\%$$

Example 6(c)—What load can be transmitted over this line at unity power factor but 15 percent regulation?

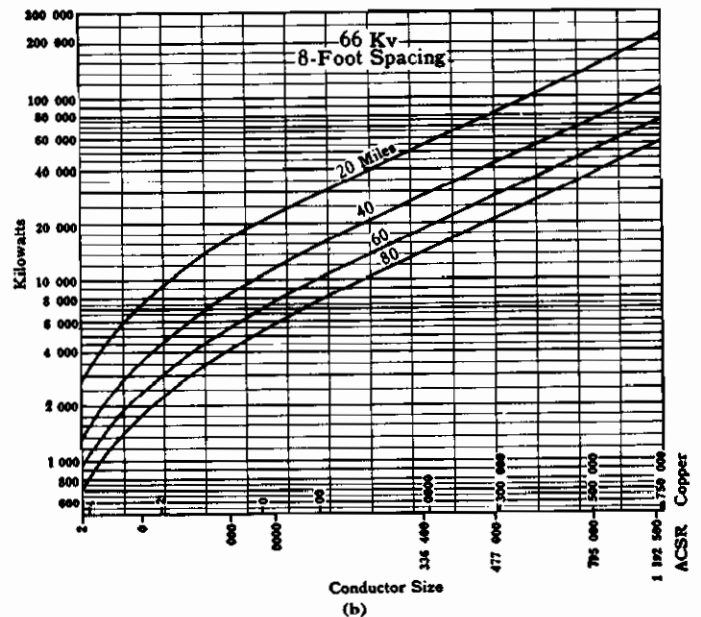
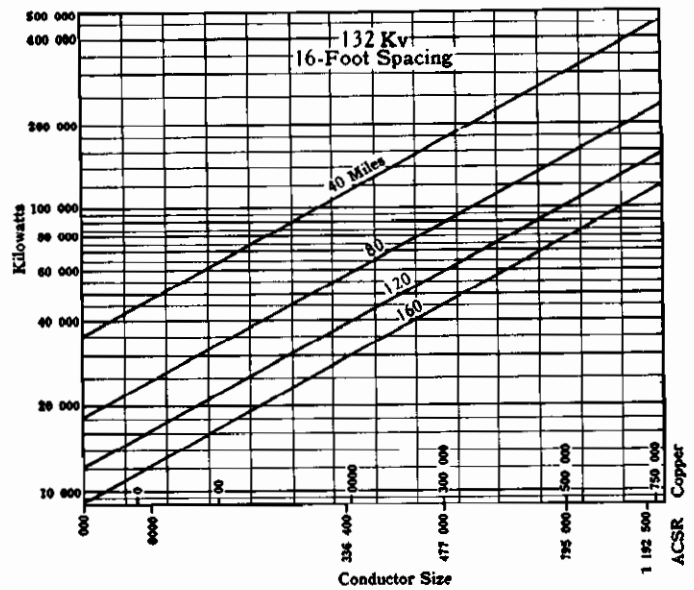
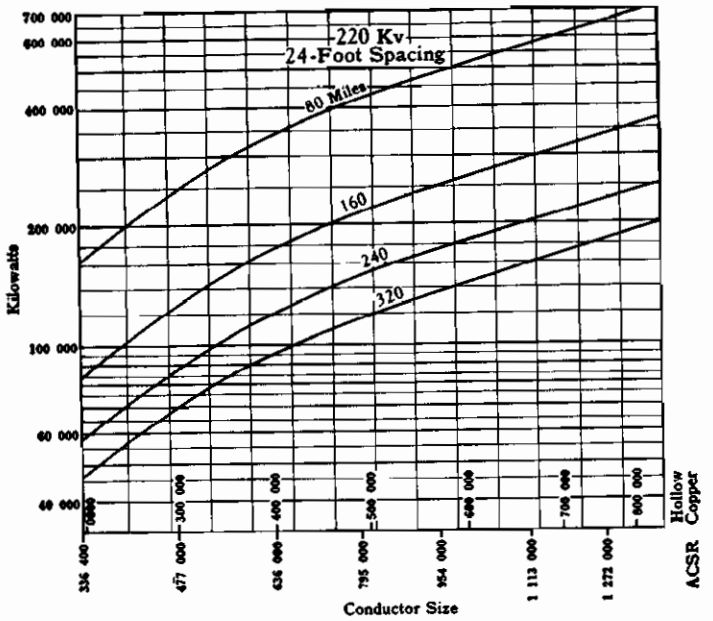
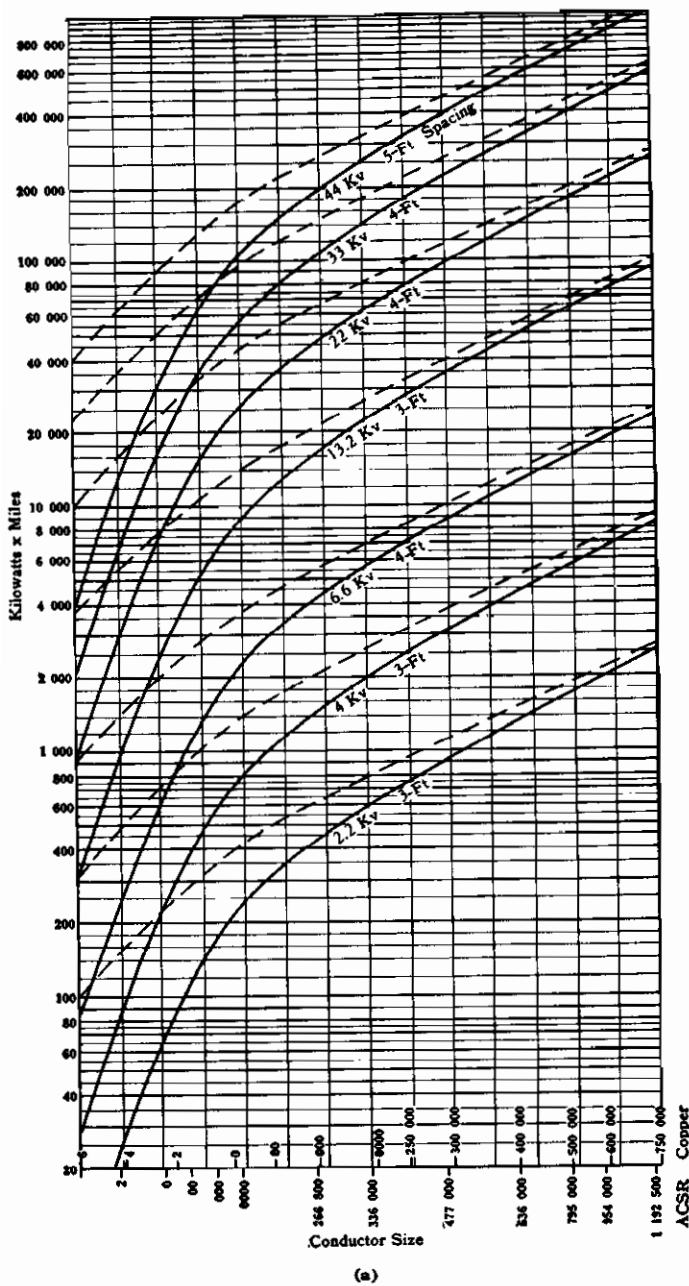

Fig. 22—Quick Estimating Charts Based Upon Percent Loss.

The solid curves are based on percent loss and equal receiving- and sending-end voltages. The dotted curves are for the maximum power which can be received at a given receiving-end voltage and percent loss.

For the curves of Fig. 22 (a) line capacitance has been neglected and power for a given length of line is value read from curves divided by line length in miles. Loss base is 5 percent.

In Fig. 22 (b) line capacitance has been taken into account and the data is thus a function of line length. Loss base is 10 percent.

For all curves:

For other values of percent loss multiply power read from curves by $\frac{\% \text{ Loss}}{5}$ for (a) and $\frac{\% \text{ Loss}}{10}$ for (b).

For single-phase lines divide power read from charts by 2.

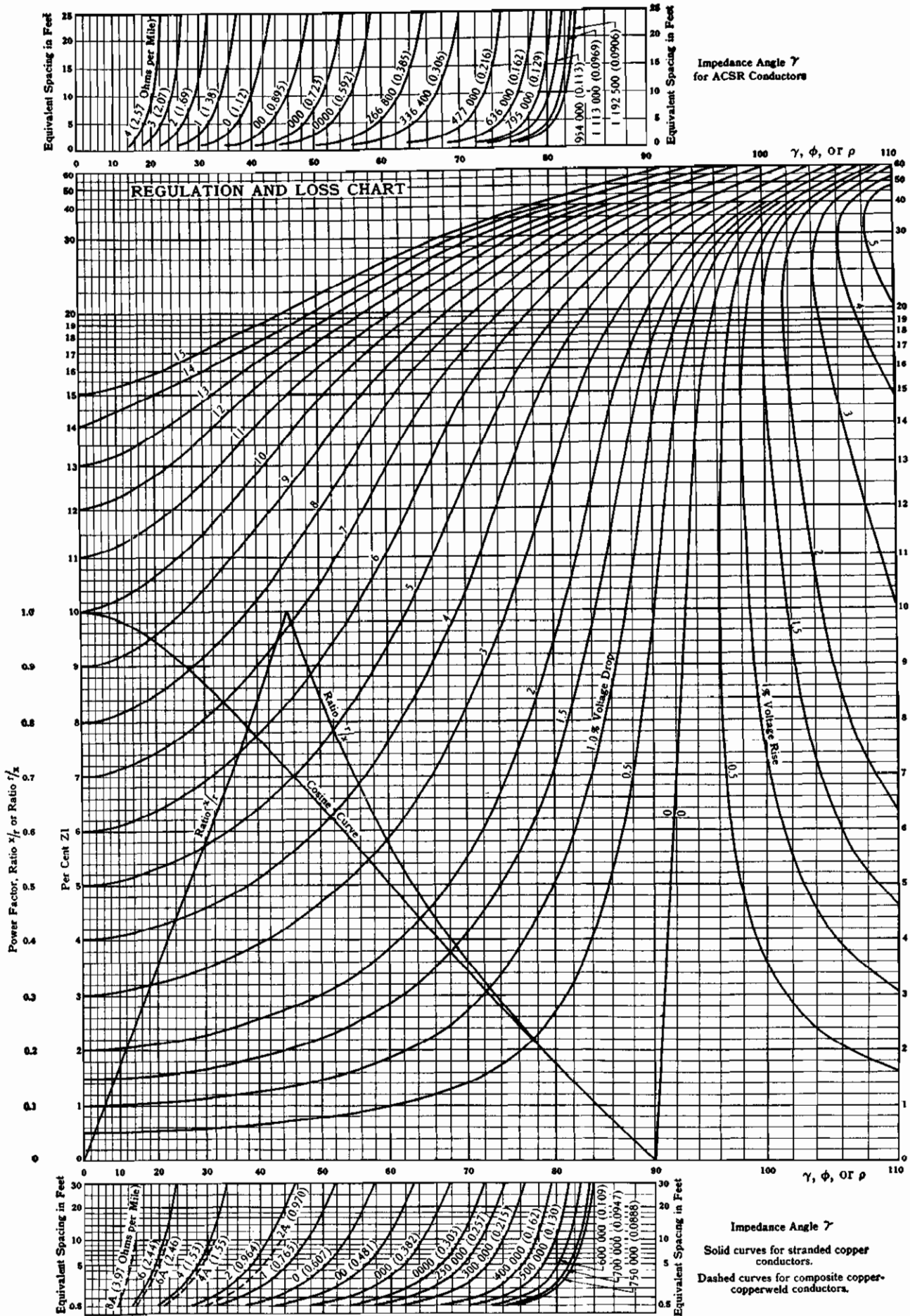

Fig. 23—Regulation and Loss Chart for transmission lines.

The answer is $(20\,000)\frac{15}{5} = 60\,000$ kw

The percent loss is $(4.2)\frac{60\,000}{20\,000} = 12.6\%$

Example 7—Determine the conductor size and voltage necessary to transmit 10 000 kw at 0.9 power factor lag for a distance of ten miles.

This corresponds to 100 000 (kw times miles). Referring to the 0.9 power factor curves for both copper and ACSR conductors for this load, it is seen that the following lines can be used:

Stranded Copper			ACSR	
Voltage	Cond. Size	% Loss	Cond. Size	% Loss
33 000	300 000 cir mil	2.5	636 000 cir mil	1.9
44 000	No. 0	4.0	No. 0000	3.7
66 000	No. 4	4.5	No. 2	5.0

If it were desired to allow a ten percent regulation instead of five percent, the value of kilowatt miles to refer to on the curves would then be 50 000 instead of 100 000.

The use of the Quick Estimating Charts based upon line loss is quite similar. For instance, if the line of example 6 were equipped with capacitors so that regulation would not be excessive, examination of Fig. 22 shows that it could deliver a maximum of $\left(\frac{116\,000}{5} = 23\,200$ kw) at five percent loss.

27. Regulation and Loss Chart

Several valuable voltage regulation charts have been developed. Perhaps the best known of these are the Dwight⁷ and Mershon⁸ charts. The chart shown in Fig. 23 provides a means of solving not only regulation but loss problems to a high degree of accuracy. It is just as simple in its use as any of the previous ones, but has the distinct advantage that it is based upon an exact solution of the vector diagram for any circuit which can be represented by a single lumped impedance. For this reason problems involving the determination of the load which can be transmitted for a given regulation can be solved much more accurately than from charts based upon approximations.

The chart is developed on the principle that for a given difference in magnitude between the sending-end and receiving-end voltages, the impedance drop (ZI) is fixed entirely by the angle $\rho = \gamma + \phi$ where $\left(\gamma = \tan^{-1}\frac{x}{r}\right)$ is the impedance angle of the line and ϕ is the power factor angle. For lagging power factors ϕ is negative and for leading power factors ϕ is positive. Thus, corresponding to various values of percent regulation, the corresponding percent ZI can be plotted as a function of the angle ρ . These are the set of curves on the chart for voltage drops from 0 to 15 percent and voltage rises from 0 to 5 percent. The value of the percent (ZI) is the same whether ρ is positive or negative. It depends only upon its magnitude.

Since the use of the chart requires a knowledge of γ and ϕ , additional curves are provided to facilitate their determination. One of these is a cosine curve for determining ϕ from the power factor. For obtaining γ from a knowledge of the resistance and reactance of the line, tangent and cotangent curves are plotted so that γ can be obtained from the ratio x/r or r/x . However, a simpler means is provided for standard conductors, by the set of curves at the top and bottom of the main portion of the chart. These curves give γ for various conductors as a function of equivalent spacing. The resistance of the conductor per mile is necessary, and it is given for each conductor. The values on the chart are for a conductor temperature of 50°C.

Although the chart is developed primarily for problems involving known receiver voltage and power factor, it can also be used for problems where the sending-end voltage and receiving-end power factor and either load current or sending end kva are known. This is the commonest type of problem involving mixed terminal conditions.

28. Use of the Regulation and Loss Chart for Short Lines

(a) **Regulation from Known Load Conditions**—to calculate regulation when receiving-end (or load) voltage, power factor, and current or kva are known:

(1) Determine $\rho = \gamma + \phi$ where the sign of ϕ is dependent upon whether the current is leading or lagging.

ϕ , the power factor angle, can be obtained from the cosine curve.

γ , the impedance angle, can be obtained by reading it from the conductor curves or by calculating r/x or x/r whichever is less than one and reading from the corresponding curve. r and x are the conductor resistance and reactance in ohms per mile.

(2) Calculate percent ZI where

$$\text{Percent } ZI = \frac{(\sqrt{3} rs I) 100}{E_L \cos \gamma} = \frac{100\,000 rs \text{ (kva)}}{E_L^2 \cos \gamma}$$

for three-phase lines (89)

$$= \frac{(2 rs I) 100}{E_L \cos \gamma} = \frac{200\,000 rs \text{ (kva)}}{E_L^2 \cos \gamma}$$

for 2-wire single-phase lines (89a)

E_L is the line voltage in volts. s is the length of the line in miles.

(3) For the calculated values of ρ and percent ZI read percent regulation from curves of constant regulation.

(b) **Load Limitation for Fixed Regulation**—To determine load limit for a given value of regulation:

(1) Determine ρ as in above and from chart for given value of regulation and ρ read the corresponding percent ZI .

$$\text{Load in kva} = \frac{(\% ZI) E_L^2 \cos \gamma}{100\,000 rs}$$

for three-phase lines (90)

$$= \frac{(\% ZI) E_L^2 \cos \gamma}{200\,000 rs}$$

for single-phase 2-wire lines (90a)

(c) **Line Efficiency**—The line loss in percent of the load kva is given by the equation

$$\text{Percent Loss} = \% RI = \% ZI \cos \gamma \quad (91)$$

where $\cos \gamma$ can be read off its cosine curve from the known value of γ . The loss can be determined in percent of the load in kilowatts by dividing the value obtained from Eq. (91) by the power factor. If it is desired to determine the percent loss for a given regulation, the percent ZI can be obtained without the use of Eq. (89). It is simply necessary to determine ρ and for this angle and the given regulation to read the (percent ZI) from the chart.

(d) **Use of Chart for Known Sending-End Voltage and Receiving-End Power Factor**—The chart can be used to as good accuracy as desired for problems of this nature. As a first approximation the regulation, in percent of the sending-end voltage, can be obtained as outlined in (a) when the sending-end line voltage is used in Eq. (89). Either the line current or the load kva expressed in terms of the sending-end voltage can be used. The load (or receiving-end) voltage can be calculated from this regulation and the sending-end voltage. This first approximation will usually give the load voltage to an accuracy of about one percent, but the percent accuracy of the regulation may be much worse depending upon its magnitude.

A more accurate value can, however, be very easily obtained by the following method of successive approximations. Using this first determined value of load voltage and then each successive value obtained, recalculate the regulation. One or two such steps will usually give very good accuracy. When calculating the percent ZI in this process it is not necessary to solve Eq. 89 each time. The new value of percent ZI can be obtained by dividing the first value calculated by the ratio of the load voltage to the sending-end voltage. This type of problem is illustrated in Example 8(d).

It is, of course, obvious that the load limit for known sending-end voltage, load power factor, and regulation can be determined as in 28(b) after the load voltage is calculated from the regulation and sending-end voltage.

29. Examples of the Use of the Regulation and Loss Chart

Consider a three-phase line ten miles long with No. 0000 stranded-copper conductors at an equivalent spacing of six feet and operating at a line voltage of 33 kv at the load end.

Example 8(a)—For rated voltage at the receiving end and a 9140 kva load at 0.9 power factor lag, determine the regulation.

Referring to the impedance angle curves for stranded copper conductors at the bottom of the chart, the impedance angle for this conductor and spacing is $\gamma = 67.2^\circ$. $\cos \gamma$ is 0.390 and the conductor resistance is 0.303 ohms per mile. Reading from the cosine curve the power factor angle for 0.9 power factor is $\phi = 26^\circ$, and the sign is minus $\rho = \gamma + \phi = 67.2^\circ - 26^\circ = 41.2^\circ$

From Eq. (89):

$$\begin{aligned} \text{Percent } ZI &= \frac{(100\,000)(0.303)(10)(9140)}{(33\,000)^2(0.390)} \\ &= 6.52 \end{aligned}$$

Reading from the chart for this percent ZI and $\rho = 41.2^\circ$, the regulation is found to be 5.0 percent.

Example 8(b)—Determine the maximum kva that can be transmitted over this line at the same power factor for a regulation of no greater than 5 percent. Reading from the chart for 5 percent regulation and ρ of 41.2° , the percent ZI is found to be 6.54.

Using Eq. (90):

$$\begin{aligned} \text{Load in kva} &= \frac{(6.52)(33\,000)^2(0.390)}{(100\,000)(0.303)(10)} \\ &= 9140 \end{aligned}$$

$$\text{Load in kw} = (9140)(0.9) = 8230.$$

Example 8(c)—As an example of the calculation of efficiency for the above case using Eq. (91):

$$\text{Percent loss} = (6.52)(0.390) = 2.55.$$

Example 8(d)—For this same line operating at a sending-end line voltage (E_{sL}) of 33 kv and a sending-end load of 9140 kva but a receiving-end lagging power factor of 0.9, determine the line voltage at the load end.

As shown in Example 8(a):

The value of percent ZI determined as a first approximation by using the sending-end voltage and kva in Eq. (89) is

$$\text{Percent } ZI = 6.52$$

$$\text{and } \rho = \gamma + \phi = 41.2^\circ$$

Thus as a first approximation

$$\text{Percent Reg.} = 5$$

$$E_L = \frac{E_{sL}}{1.05} = 31.42 \text{ kv.}$$

As a second approximation

$$\text{Percent } ZI = (1.05)(6.52) = 6.85$$

reading from the chart for percent $ZI = 6.85$ and $\rho = 41.2^\circ$

$$\text{Percent Reg.} = 5.20$$

$$E_L = \frac{E_{sL}}{1.052} = 31.35 \text{ kv.}$$

As a third approximation

$$\text{Percent } ZI = (1.052)(6.52) = 6.87$$

Percent Reg. = 5.25 (as closely as can be read from the chart)

$$E_L = \frac{E_{sL}}{1.0525} = 31.34 \text{ kv.}$$

30. Use of Regulation and Loss Chart for Long Lines

As shown in Sec. 16, methods of calculating regulation for short lines can be applied to lines up to 100 miles in length to a good degree of accuracy by simply adding the correction factor ($-2.01S^2$) to the percent regulation where S is the length of the line in hundreds of miles.

If greater accuracy is desired, the chart can be used with the equivalent load current and power factor obtained as described in Sec. 14. Using this method both regulation and efficiency can be determined.

31. Determination of Effect of Transformers on Line Performance

The chart can be used as described in Sec. 28 for determining regulation and efficiency of transformers al-

though the transformer charts in Chap. 5 are simpler. In considering the performance of a line and transformers together, however, the chart can be used to advantage. The impedance of the transformers can be combined with that of the line into a single impedance. These impedances can be expressed either in ohms or in percent on some common kva base. Transformer impedance is usually given in percent. It can be expressed in ohms by the equation

$$Z_{(\text{ohms})} = \frac{Z_{(\text{percent})} E_{L(\text{kv})}^2 (10)}{\text{kva}} \quad (92)$$

The transmission line impedance in ohms can be transformed to a percent basis by the equation

$$Z_{(\text{percent})} = \frac{Z_{(\text{ohms})} (\text{kva})}{E_{L(\text{kv})}^2 (10)} \quad (93)$$

The transmission line resistance can be read directly from the chart and the reactance obtained from the chart by reading the line impedance angle γ from the chart and the ratio of r/x or x/r for this angle.

For problems of this type it is usually easier to use the impedance in percent. After having obtained the total equivalent percent R and percent X , the equivalent angle γ can be read from the curves for the ratio of R/X or X/R . The percent ZI can be calculated from the equation

$$\text{Percent } ZI = \frac{(\%RI = \%R) (\text{rated load})}{\cos \gamma} \frac{(\text{actual load})}{(\text{rated load})} \quad (94)$$

Example 9—As an example of the calculation of a problem of this type consider the 10 mile, 33 kv, 300 000 cir mil stranded copper line found adequate for the (10 000 kw = 11 111 kva) load at 0.9 power factor lag of Example 7.

Assume that it has transformers at each end rated at 12 000 kva with 0.7 percent resistance and 5 percent reactance, and let us calculate the total regulation and loss of the system.

Reading from the chart

The line resistance is $(0.215)(10) = 2.15$ ohms
 r/x for the line impedance angle of 71.6° is 0.330

The line reactance is $\frac{2.15}{0.330} = 6.51$ ohms

The percent impedance of the line on a 12 000 kva base is from Eq. (93).

$$\text{Percent } Z_L = \frac{(2.15 + j6.51)(12\ 000)}{(33)^2(10)} = 2.37 + j7.16$$

The total impedance is

$$\begin{aligned} \text{Percent } Z &= (2.37 + j7.16) + 2(0.7 + j5) \\ &= 3.77 + j17.16 \\ \frac{\%R}{\%X} &= \frac{3.77}{17.16} = 0.219 \end{aligned}$$

Reading from the chart for this ratio

$$\gamma = 77.7^\circ$$

$$\cos \gamma = 0.219$$

$$\text{For 0.9 power factor } \phi = -26^\circ$$

$$\rho = 51.7$$

From Eq. (94)

$$\text{Percent } ZI = \left(\frac{3.77}{0.219} \right) \left(\frac{11\ 111}{12\ 000} \right) = 15.94$$

The regulation read from the chart for this percent ZI and the calculated value of ρ is

$$\text{Regulation} = 10.5\%$$

The loss in percent of the load in kw is from Eq. (91)

$$\text{Percent Loss} = \frac{(15.94)(0.219)}{0.9} = 3.88.$$

REFERENCES

1. *Principles of Electric Power Transmission*, by L. F. Woodruff (a book), John Wiley & Sons, Inc. Second Edition, p. 106.
2. *Tables of Complex Hyperbolic and Circular Functions*, by Kennelly (a book), Harvard University Press.
3. *Chart Atlas of Complex Hyperbolic and Circular Functions*, by Kennelly (a book), Harvard University Press.
4. Transmission Line Circuit Constants, by R. D. Evans and H. K. Sels, *The Electric Journal*, July 1921, pp. 307-390 and August 1921, pp. 356-359.
5. Circle Diagram for Transmission Lines, by R. D. Evans and H. K. Sels, *The Electric Journal*, December 1921, pp. 530-536 and February 1922, pp. 53 and 59.
6. Some Theoretical Considerations of Power Transmission, by C. L. Fortescue and C. F. Wagner, *A.I.E.E. Transactions*, V. 43, 1924, pp. 16-23.
7. A Chart for the Rapid Estimating of Alternating Current Power Lines, by H. B. Dwight, *The Electric Journal*, July 1915, p. 306.
8. *Electrical Characteristics of Transmission Circuits*, by William Nesbit (a book), Westinghouse Technical Night School Press. Third Edition, pp. 43-45.
9. *The Transmission of Electric Power*, by W. A. Lewis (1948 Lithoprinted Edition of Book), Illinois Institute of Technology.

CHAPTER 10

STEADY-STATE PERFORMANCE OF SYSTEMS INCLUDING METHODS OF NETWORK SOLUTION

Original Author:

E. L. Harder

Revised by:

E. L. Harder

A POWER system must generate, transmit, and then distribute electric power to the desired points, reliably and in good condition. The electrical performance of the system as dealt with in this chapter is the measure of how well it performs this task and is expressed by such quantities as voltage regulation, loading of lines and equipment, efficiency and losses, and real and reactive power flow. Stability, of vital importance also, is dealt with in Chap. 13.

The key to the determination of such system quantities is the *network solution*, or determination of currents and voltages throughout the system for any prescribed conditions. From the network solution can be determined all of the essential electrical characteristics that are dependent upon the fundamental-frequency currents and voltages.

Network solution is based on Kirchoff's two laws:

First, that the vector sum of all the voltages acting around any closed loop is zero.

And second, that the vector sum of all the currents flowing to any point is zero.

In the course of applying these elementary principles to the solution of thousands of linear networks for many years, various investigators have found several powerful theorems that follow directly therefrom, such as the superposition theorem¹, the reciprocal theorem, and Thevenin's theorem. These theorems not only assist in visualizing the phenomena taking place in the circuits, but also greatly simplify and systematize the work of solution for the species of networks to which they apply.

The method of symmetrical components, given in Chap. 2 is a highly developed special application of the superposition theorem, taking advantage of the symmetry of the several phases of the usual polyphase power system.

The direct use of Kirchoff's Laws can be designated as "Solution by Equations," to distinguish it from "Solution by Reduction" in which portions of a system are progressively replaced by simpler equivalents until a single branch remains. This latter makes use of the superposition theorem in treating one emf at a time. Also, it utilizes equivalent circuits, many of which are now available.

Thevenin's theorem and the superposition theorem have provided direct methods for obtaining solutions in networks of several fixed emfs, with enormous simplification.

Solutions of networks can be expressed in many forms, each one being particularly adaptable to certain types of networks or certain problems. Thus, the expression of solutions as "Self and Mutual Drops and Current Division"

is particularly well suited to regulation and apparatus loading studies. The method of Driving Point and Transfer Admittances or Impedances is well suited to power flow or stability studies on multiple-entrance systems, and the General Circuit Constants, *ABCD*, or the equivalent *Pi* and *T* are similarly advantageous for the transmission-type network having two significant terminals.

These methods of network representation and solution constitute a highly developed science with extensive present literature. However, as they constitute the heart of the problem of steady-state performance of systems as well as of many other system problems, a large part of this chapter will be devoted to them. In general, the most commonly used methods will be outlined and illustrated by examples. For further information a bibliography of selected references is included.

Network solution, once accomplished largely by analytical methods, is now performed to an increasing extent by a-c and d-c network calculators. However, many problems are still solved analytically and also a thorough knowledge of methods of network representation and solution is as essential as ever to the system designer. Fortunately, however, the calculator has removed the enormous burden of routine calculation and has made it economically possible to solve complicated systems. Analytic methods are still largely used for the simpler studies or where network calculators are not available.

I. NETWORK REPRESENTATION

1. Single-Line Diagram. Fig. 1

In dealing with power systems of any complexity, one of the first essentials is a single-line diagram, in which each polyphase circuit is represented by a single line. Stripped of the complexity of several phase wires, the main power channels then stand out clearly, and the general plan of the system is evident. Most power companies maintain up-to-date single-line diagrams of their systems.

This diagram is a short-hand or symbolic representation of the principal connections, showing the equipment in its correct electrical relationship and usually having indicated on it, or in supplementary tabulations, data essential for the determination of the impedance diagram. The recommended symbols for apparatus are given in Table 1(a). In addition, auxiliary symbols, Table 1(b), are inscribed near the devices in question, to indicate the winding connections and the grounding arrangement, if any, at the

TABLE 1(a)—GRAPHICAL SYMBOLS FOR DIAGRAMS^o—EQUIPMENT SYMBOLS

NAME	ONE LINE	COMPLETE *	NAME	ONE LINE	COMPLETE *
A. C. GENERATOR OR MOTOR [†]			DOUBLE THROW SWITCH		
SYNCHRONOUS CONVERTER			OIL CIRCUIT BREAKER, SINGLE THROW		
DIRECT CONNECTED UNITS BASIC SYMBOL (Use particular symbols and join as here shown.)			AIR CIRCUIT BREAKER		
TWO-WINDING TRANSFORMER [†] BASIC SYMBOL			FUSE		
THREE-WINDING TRANSFORMER [†]			RESISTOR		
AUTOTRANSFORMER [†]			REACTOR		
CURRENT TRANSFORMER			CAPACITOR		
POTENTIAL TRANSFORMER			LIGHTNING ARRESTER		
INDUCTION VOLTAGE REGULATOR			POTHEAD CABLE TERMINAL		
DISCONNECTING OR KNIFE SWITCH			DRY RECTIFIER		
AIR BREAK SWITCH, HORN GAP, GROUP OPERATED			MERCURY ARC RECTIFIER		

* The "Complete" symbol is intended to illustrate the method of treatment for any desired polyphase combination rather than to show the exact symbol required. Use symbol (m) for windings of apparatus as required, and connect to suit particular case.

† Inscribe winding connection diagram symbol from Table 1b.

o For complete lists see American Standards Z32.3-1946, Z32.12-1947

neutral. The use of these auxiliary symbols is illustrated in Fig. 1.

Similar diagrams showing circuit breakers and disconnecting switches are used as power-system operating diagrams. Or they can be marked with suitable symbols to show the relay (See Chap. 11) or lightning protection.

2. The Sign of Reactive Power

The + sign used with the reactive-power terms in the loads of Fig. 1 designate lagging-reactive power in accordance with the standard notation approved by the AIEE Standards Committee on Jan. 14, 1948 and recommended for adoption to the American Standards Assn. and the IEC. Since this is a change from the convention used in editions 1 to 3 of this book the history of this standard

and its implications are discussed in detail here.

The complete specification of real- and reactive-power flow in a circuit requires:

First, an indication of the direction spoken of, i.e., a reference-positive direction.

Second, numerical values and associated signs. The numerical values give the magnitude of the real- and reactive-power components respectively. The associated signs show whether they flow in the reference-positive direction or not.

Third, there must be a convention as to whether it is lagging-reactive power or leading-reactive power, the direction and magnitude of which is being specified.

Lagging-reactive power is that which is generated or supplied by an over-excited synchronous machine or by a

TABLE 1(b)—GRAPHICAL SYMBOLS FOR DIAGRAMS—WINDING CONNECTION SYMBOLS

NAME	SYMBOL
TWO-PHASE, THREE-WIRE	L
TWO-PHASE, FOUR-WIRE	+
THREE-PHASE, DELTA (OR MESH)	Δ
THREE-PHASE, Y (OR STAR)	Y
THREE-PHASE, Y (OR STAR) WITH NEUTRAL BROUGHT OUT AND GROUNDED	Y _g
THREE-PHASE, Y (OR STAR) WITH NEUTRAL GROUNDED THROUGH A RESISTOR	Y _r
THREE-PHASE, ZIG-ZAG	Z
THREE-PHASE, T	T

static capacitor and used by inductive loads such as induction motors, reactors, and under-excited synchronous machines.

According to the convention recommended by AIEE in 1948 and used throughout this book the positive sign for reactive power indicates that lagging-reactive power is flowing in the reference-positive direction. The vector relationship for power is therefore:

$$P + jQ = E\hat{I}$$

For example if E is taken as reference, $E = \bar{E}$ and if $I = \bar{I}' - j\bar{I}''$ is a lagging current, \bar{I}' and \bar{I}'' being positive quantities, the real power is $P = \bar{E}\bar{I}'$ and the lagging-reactive power is $Q = \bar{E}\bar{I}''$.

The expression,

$$P + jQ = E\hat{I} = \bar{E}(\bar{I}' + j\bar{I}'') = \bar{E}\bar{I}' + j\bar{E}\bar{I}''$$

results in the proper sign for the P and Q terms, whereas $\hat{E}I$ would give the right values but the wrong sign for the Q term. With this new convention, and taking E as reference, the power vector $P + jQ$ lies along the conjugate of the current vector. Consequently current and power circle diagrams lie in conjugate quadrants.

Historical Summary—Originally there was one school of thought, typified by Evans, Sels⁶, and others, that used the positive sign for lagging-reactive power for the same reasons that it has now finally been adopted. The principal reasons were these. Like real power, lagging-reactive power is generally used in the load and must be supplied at some expense in the supply system. It is thus the commodity dealt with by the practical power-system designer, and dispatched by the operators. This concept is consistent mathematically with the following forms:

Power associated with voltage E and current I is:

$$P + jQ = E\hat{I}$$

and power in an impedance Z to a current I is:

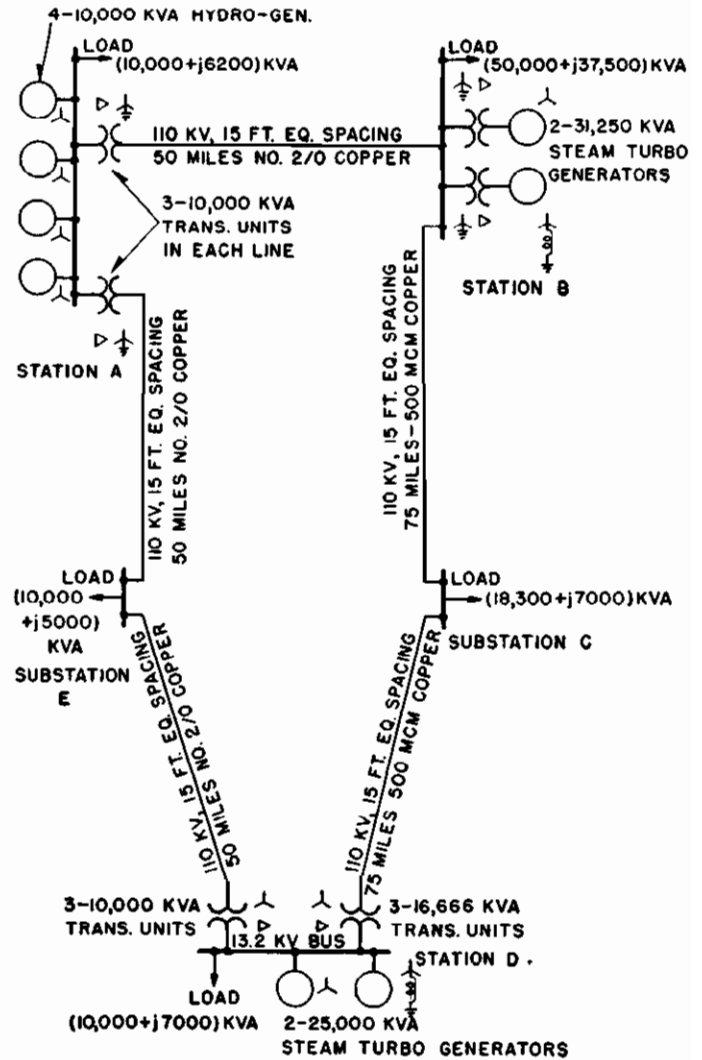

Fig. 1—Single-line diagram of a power system.

$$P + jQ = \bar{I}^2 Z$$

The form $P + jQ = \bar{E}^2 Y$ is then erroneous and gives the wrong sign for Q .

For the conventional transmission line, with this concept (lagging-reactive power positive) the center of the sending-end power-circle diagram lies in the first quadrant and the center of the receiving circle in the third quadrant.

The other school of thought used leading-reactive power as positive, lagging-reactive power as negative. This had the theoretical advantage of throwing current and power circle diagrams into the same quadrant, but the disadvantage that lagging-reactive power, the reactive commodity usually dispatched by power-system operators, was then a minus quantity. This concept is consistent with the mathematical forms:—

Power associated with a voltage E and a current I is:—

$$P + jQ = \hat{E}I$$

Power flowing into an admittance Y due to a voltage E is:

$$P + jQ = \bar{E}^2 Y$$

The form $P + jQ = \bar{I}^2 Z$ is then erroneous and gives the wrong sign for Q .

The latter school, (leading-reactive power positive) won out, for the time being, on the basis of the theoretical considerations, and on August 12, 1941 the American Standards Association approved this convention as an industry standard, C42-1941, Section 05.21.050. The first three editions of this book followed this standard convention. However, the convention was never followed by system-planning and operating people to any extent. They continued to dispatch lagging-reactive power which they called simply "reactive," and to mark on their flow charts the direction in which lagging-reactive power flowed. They could not be converted to selling a negative amount of leading-reactive power for positive money, but preferred to sell a positive amount of lagging-reactive power.

A majority of engineers have now come to consider lagging-reactive power as the commodity being dealt with. The AIEE Standards Committee recognizing this *fait accompli* recommended to ASA in 1948 adoption of the convention making lagging-reactive power positive. This reference book has, starting with the fourth edition, 1950, been changed to conform with what will undoubtedly be the standard from now on, namely, lagging-reactive power positive.

Teachers and writers can materially aid in eliminating confusion by discontinuing all use of the term leading-reactive power which after all is simply an unnecessary name for the negative of lagging-reactive power. Such a term is no more necessary than a name for the negative of real power. Eventually if this is followed the adjective "lagging" can be dropped, as reactive power will always mean lagging-reactive power.

3. Impedance Diagram. Fig. 2

The second essential in analytic study of a power system is the impedance diagram, on which are indicated on a common basis, the impedances of all lines and pieces of equipment related to the problem. Because of the symmetry of phases it is usually sufficient to represent only one phase—called the reference phase, or a phase. Under balanced conditions of operation, the currents and voltages in the other two phases are exactly equal to those in a phase and merely lag behind the a phase quantities by 120 and 240 electrical degrees. Hence, when the a phase quantities have been determined, the others follow directly.

Even when unbalances, such as a line-to-ground fault, or one-wire-open, occur at one or two points of an otherwise balanced polyphase system, the impedance diagrams for the reference phase are sufficient, if use is made of the method of symmetrical components as outlined in Chap. 2.

The impedance diagram, corresponding to the system shown in Fig. 1, is given in Fig. 2. Generator impedances are not shown as they do not enter into the particular problem. All impedances on this diagram have been expressed in ohms, and admittances in mhos, on a 110-kv base. Actually there are several choices, such as percent or per unit on various kva bases or ohms on voltage bases other than 110-kv. The relations between these several methods, and factors affecting the choice are discussed subsequently.

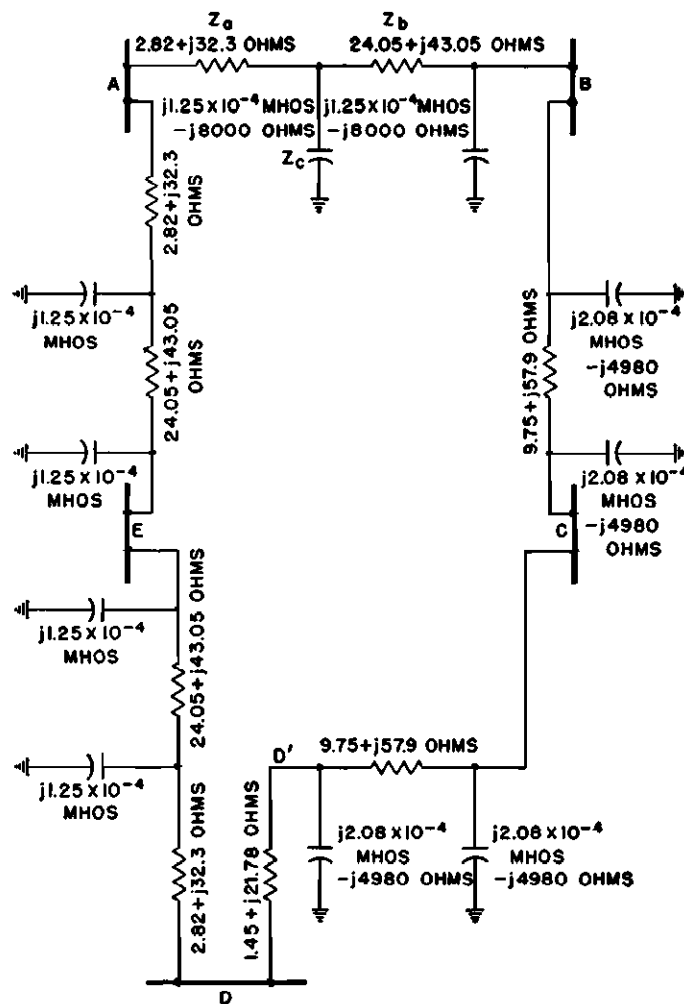

Fig. 2—Impedance diagram of a system shown in Fig. 1.

4. Determination of Impedances

In general, accurate cable and overhead-line impedances can be obtained from the tabulations of Chaps. 4 and 3, in terms of the wire size and spacing. Average apparatus constants are given in the tabulations of Chap. 6, Machine Characteristics, and Chap. 5, Power Transformers and Reactors. More accurate figures, if required, can be obtained from name-plates or direct from the manufacturer of the equipment. The impedances of lines and transformers in Fig. 2 have been obtained, for example, from the tables of Chaps. 3 and 5 based on the data given in Fig. 1.

Representation of Loads—The necessary representation of loads in the impedance diagrams depends upon the use intended. In short-circuit studies, loads are most frequently neglected. In stability studies, they must generally be considered. Several methods of representing loads are as follows:

- Shunt impedance that draws the same kilowatts and reactive kva at normal voltage as is drawn by the actual load.
- An impedance circuit, which, for any conditions of voltage is adjusted to draw the desired amount of real and reactive power.

- c. In network calculator studies, the use of a "source"† adjusted, in phase angle and magnitude, to draw the desired real and reactive power from the system.
- d. Given any characteristics of variation of real and reactive power with voltage, the load can be converted to impedance at the expected voltage, this impedance used in determining the system voltages, and then the load impedance corrected to the new voltage if such correction is warranted.

Conversion of Load Kw and Reactive Kva to Ohms or Mhos—Loads given in kilowatts and reactive kva can be converted to impedance or admittance form by the following equations:

Let $P = \text{kw (three-phase)}$
 $Q = \text{reactive kva lagging ‡(three-phase)}$
 $E_{L-L} = \text{line-to-line voltage in kv at which the conversion is to be made.}$
 $Z = \text{vector impedance value, ohms line-to-neutral.}$
 $Y = \text{vector admittance value, mhos, line-to-neutral.}$

$$Z = \frac{1000E_{L-L}^2}{P - jQ} = \frac{1000E_{L-L}^2}{P^2 + Q^2}(P + jQ)$$

$$= \frac{1000(\text{kv})^2}{\text{kw} - j \text{ reactive kva (lagging)}} \text{ohms, line-to-neutral} \quad (1)$$

$$Y = \frac{P - jQ}{1000E_{L-L}^2} = \frac{\text{kw} - j \text{ reactive kva (lagging)}}{1000(\text{kv})^2}$$

$$\text{mhos, line-to-neutral} \quad (2)$$

For example, at 13.8 kv a load of 10 000 kva at 80 percent power factor lagging may be expressed as:

$$P = 8000 \text{ kw} \quad Q = +6000 \text{ reactive kva}$$

The impedance required to represent it is:

$$Z = \frac{1000(13.8)^2}{(6000)^2 + (8000)^2}(8000 + j6000) = 15.2 + j11.4 \text{ ohms,}$$

$$\text{line-to-neutral}$$

and the admittance is:

$$Y = \frac{8000 - j6000}{1000(13.8)^2} = 0.0420 - j0.0315 \text{ mhos, line-to-neutral.}$$

Y and Z as given above are the admittance or impedance values to be used in the single-phase impedance diagram in which only the reference phase and neutral are represented.

Shunt Capacitors are built to a tolerance of -0 to $+10$ percent of their rated kva, $+5$ percent being the average. It is generally sufficiently accurate to consider the reactance to be 100 percent based on 105 percent of the rated kva base.

Series Capacitors—The determination of reactance of a series capacitor can best be explained by example. Suppose ten standard 15-kva single-phase, 440-volt, shunt-capacitor units have been used in parallel in each phase, or a total of 150 kva per phase. The capacitive reactance presented in series in each phase is then:

†The "sources" are voltage regulator-phase shifter circuits from a main power bus and can be readily adjusted to either draw or feed the desired quantities of real and reactive power.

‡ Q is positive for lagging reactive kva.

$$X_s = \frac{1000(\text{kv})^2}{1.05^*(\text{kva})} = \frac{1000(0.44)^2}{1.05 \times 150} = 1.22 \text{ ohms} \quad (5)$$

This ohmic value can be converted to percent by Eq. (12).

Shunt Reactors have 100-percent voltage drop across them when connected to normal voltage, or have 100-percent impedance based on the kva drawn from the system at normal voltage.

Series Reactors—The reactance of a series reactor is frequently expressed in percent, but the kva of its parts is given. Thus, if a 6-percent reactor is desired in a circuit having a rating of 10 000 kva, three-phase, the reactor rating will be 600 kva, three-phase (6 percent of 10 000 kva). Three 200-kva single-phase reactors might be used. These would ordinarily be referred to as three 200-kva, 6-percent reactors, whereas actually they constitute a three-phase reactance in the circuit having 6-percent reactance on a 10 000-kva base. Care must be taken, therefore, to determine the reactance value on the through or transmitted kva base, or 10 000-kva base in the example cited. The relation between reactor kva, and through kva are as follows:

Reactor three-phase kva rating = a
 Through or transmitted kva rating = A
 Percent reactance on the transmitted kva base = X

$$\text{Then} \quad a = \frac{X}{100}A \quad (3)$$

Given the reactor three-phase kva rating, a , the through kva rating is

$$A = \frac{100}{X}a \quad (4)$$

The reactor has a reactance of X percent on the kva base A .

In the case cited above of a 600-kva, 6-percent reactor, Eq. (4) gives $A = \frac{100}{6} \times 600 = 10\,000$. Whence, the reactor has a reactance of 6 percent on a 10 000-kva base.

The standard reactance tolerance of current-limiting reactors is -3 percent to $+7$ percent for single-phase and -3 percent to $+10$ percent for three phase. The rated reactance is generally used in system calculations unless test figures are available.

5. Conversions. Percent to Ohms and Ohms to Percent†

Method 1—If a base kva (three-phase) and kv (line-to-line) are selected, the corresponding normal or base current, line-to-neutral voltage, and impedance values can be immediately determined.

They are:

$$\text{Normal Current } I_n = \frac{\text{kva}}{\sqrt{3}(\text{kv})} \text{ amperes} \quad (6)$$

$$\text{Normal Voltage (line-to-neutral) } E_n = \frac{1000(\text{kv})}{\sqrt{3}} \text{ volts} \quad (7)$$

$$\text{Normal Impedance } Z_n = \frac{E_n}{I_n} \text{ ohms per phase, line-to-neutral.} \quad (8)$$

*If the ratio of actual to rated kva is known, it should be used in place of 1.05.

†(Note: Per Unit is percent divided by 100).

From these relations any percent impedance can be converted to ohms.

$$\begin{aligned} \text{Ohms} &= (\text{normal impedance}) \left(\frac{\text{percent impedance}}{100} \right) \\ &= Z_n \left(\frac{\%}{100} \right) \end{aligned} \quad (9)$$

Conversely any ohmic figure can be converted to percent.

$$\text{Percent} = 100 \left(\frac{\text{ohms}}{\text{Normal Impedance}} \right) = 100 \left(\frac{\text{ohms}}{Z_n} \right) \quad (10)$$

Method 2—The magnitude of Z_n from (8), (7), and (6) can be substituted in (9) and (10) and gives direct conversions:

$$\text{Ohms} = (\%) \left(\frac{10 \text{ kv}^2}{\text{kva}} \right) \quad (11)$$

$$\text{Percent} = \text{ohms} \left(\frac{\text{kva}}{10 \text{ kv}^2} \right) \quad (12)$$

For example, a 15 000-kva, 13.8-kv to 66-kv transformer bank has a reactance of 8 percent on the 15 000-kva base. Let it be required to determine its impedance in ohms on a 66-kv base.

Normal current:

$$I_n = \frac{15\,000}{66 \sqrt{3}} = 131 \text{ amperes.}$$

Normal voltage:

$$E_n = \frac{66\,000}{\sqrt{3}} = 38\,100 \text{ volts, line-to-neutral.}$$

Normal impedance:

$$Z_n = \frac{38\,100}{131} = 291 \text{ ohms per phase, line-to-neutral.}$$

Transformer impedance = 8 percent of 291
= 23.3 ohms per phase at 66 kv.

The direct determination from (11) is,
Transformer impedance

$$= \frac{8(66)^2(10)}{15\,000} = 23.3 \text{ ohms per phase.}$$

The first method is longer, but gives other information generally required in the problem, and has some advantage in visualizing the procedures.

6. Conversions to a Different Kva Base

From (12) it is apparent that for a given ohmic impedance the percent impedance varies directly with the kva base selected. Thus 10-percent impedance on a 10 000-kva base becomes 100-percent impedance on a 100 000-kva base. When using percent impedances, all percentages should be expressed on the same kva base.

7. Conversions to a Different Voltage Base

In system studies if impedances are expressed in ohms it is desirable to convert them all to a common voltage base so that transformer turns ratios need not be considered in the subsequent calculations. The terms "voltage ratio"

and "turns ratio" are often used loosely as synonymous terms, until more precise or important calculations are being made for which it is desired to be quite accurate. Then the question sometimes arises as to whether impedances should be transferred to the voltage base on the other side of a transformer on the basis of its voltage ratio or its turns ratio. It is actually the turns ratio that counts and should be used as will be shown later in this section. The turns ratio is the same as the nameplate voltage ratio but differs from the terminal voltage ratio under load.

Also in approximate calculations it is frequently assumed that for all parts of the system of the same nominal voltage the same transformation ratio can be used to the desired voltage base. This is a rough approximation and becomes exact only if the transformer turns ratios between parts of the system at the same nominal voltage are all unity. Barring this, one correct procedure is to select some one point of the system as a base and transform all other impedances to this base by multiplying by the square of the intervening turns ratios. Once all impedances are on a common base they can all be transformed by a single multiplier to any other voltage base.

When impedances are in percent on a given kva base the percent refers to a given normal voltage. Thus strictly two conditions must be fulfilled in sequence for percent impedances to be used in network solutions. First, the normal voltages to which the percentages refer must be in the same ratios as transformer turns ratios throughout the system. Second, the normal voltage used in converting the answers from percent to amperes and volts must be the same as the normal voltages on which the percent impedances are based. Otherwise approximations are involved. These approximations can be eliminated by suitable transformations beyond the scope of this chapter except for the following general method.

Where doubt exists as to the correct direct transformation of percent impedance, the impedance of each element can be converted to ohms. The ohmic values can be converted to a common base as described above and combined. The result can be reconverted to percent on any desired kva and voltage base. This is the general procedure by which rules for direct percent-impedance transformations are derived.

The pitfall of ignoring near-unity turns ratios extends to voltage also. Suppose a 13.8-kv generator feeds through step-up and step-down transformers to a 13.8-kv distribution system and that impedances have been expressed on the distribution system voltage base. Suppose further that there is a resultant 1:1.1 step-up turns ratio between the generator and the distribution system. Then a generator operating at 13.8 kv would be at $13.8 \times 1.1 = 15.18$ kv on the 13.8-kv voltage base of the distribution system, and must be so treated in the calculations. Similarly, for calculations in percent, the same machine must be treated as operating at 110 percent voltage. The theoretical basis upon which all such transformations rest, and examples of their correct use is given in the following paragraphs.

From an energy or power standpoint, no change is made if all voltages are multiplied by a constant, N , all currents divided by N , all impedances multiplied by N^2 , and all admittances divided by N^2 . When two circuits are sepa-

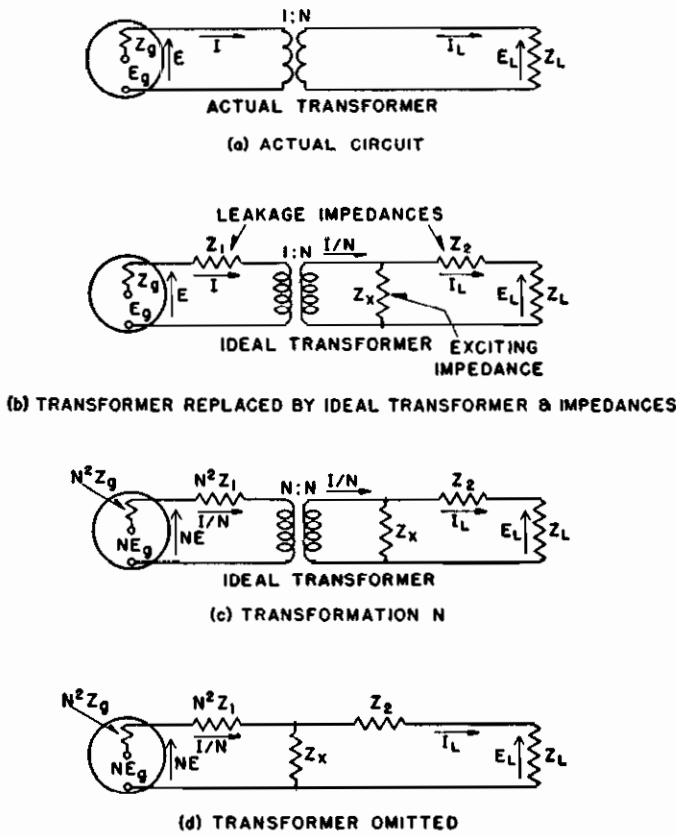

Fig. 3—Power invariant transformation.

rated by an ideal transformer* of turns ratio N , such an operation performed on the quantities on one side of the transformer with a corresponding change in the transformer ratio, has the advantage of bringing the currents and voltages on the two sides to an equality. A direct connection can be made and the ideal transformer can be omitted from the diagram (see Fig. 3). Solutions can be made with the quantities on the fictitious or transformed voltage base, and they can be reconverted to actual quantities whenever desired.

An actual transformer differs from an ideal transformer in two respects only. It has primary and secondary resistances and leakage reactances, which are no different than the same impedance connected externally. Its primary and secondary ampere-turns differ by a small quantity of exciting ampere-turns that excite the core. A shunt branch can be connected which draws the requisite exciting current if important in the particular problem.

Example—As an example consider the circuit of Fig. 4, a generator, transformer and high-voltage line with a three-phase short circuit at the end. Suppose the short-circuit currents are to be determined. This problem will also illustrate that calculations can be made interchangeably with impedances in ohms on any voltage base or in percent on any kva base.

The generator reactance (assumed 15%) in ohms is from (11):

*A transformer having zero exciting current and zero leakage impedance.

$$\frac{(15)(10)(13.8)^2}{50\,000} = 0.571 \text{ ohms at } 13.8 \text{ kv}$$

The transformer reactance in ohms is:

$$\frac{(9)(10)(13.8)^2}{50\,000} = 0.343 \text{ ohms at } 13.8 \text{ kv.}$$

The line impedance is, from Chap. 3.

$$9.75 + j57.9 \text{ ohms at } 110\text{-kv. [See Fig. 4(c)]}$$

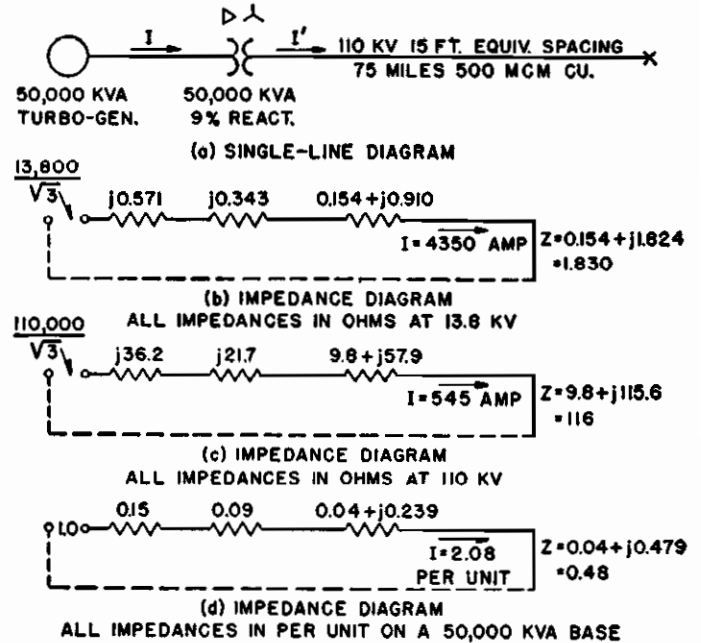

Fig. 4—Problem illustrating the expression of ohms on various voltage bases and the relation to percent on a kva base.

The shunt impedances of this line are high (line CD' Fig. 2) and will be neglected for simplicity in this problem.

Use of Generator Voltage Base—If the current in the generator is desired, it will be most convenient to express all impedances on the generator voltage base. The generator and transformer impedances are already on this base. The line impedance is converted to it by multiplying by the square of the turns ratio, usually taken as the nameplate voltage ratio corresponding to the taps in use. Thus the line impedance is:

$$(9.75 + j57.9) \left(\frac{13.8}{110} \right)^2 = 0.154 + j0.910 \text{ ohms at } 13.8 \text{ kv.}$$

The impedance diagram of Fig. 4(b) results, in which all impedances are expressed in ohms on a 13.8-kv base. The fault current in the generator is then:

$$I = \frac{13\,800}{\sqrt{3}(1.830)} = 4350 \text{ amperes.}$$

The current flowing in the line is:

$$I' = 4350 \left(\frac{13.8}{110} \right) = 545 \text{ amperes.}$$

Use of Line Voltage Base—A similar result would be obtained if the generator and transformer reactances had

been converted directly from percent to ohms at 110-kv. The impedance diagram, Fig. 4(c) would then result, the fault current being calculated directly for the line and requiring a conversion (multiplication by $\frac{110}{13.8}$) to determine the current in the generator.

Use of Percent on a Kva Base—A third method of approach is to convert the line impedance to percent on a kva base, and “work in percent.” A convenient base will be 50 000 kva since two of the impedances are already known on this base. The line impedance is, from Eq. (12):

$$\frac{(9.75 + j57.9)(50\,000)}{(10)(110)^2} = (4.0 + j23.9)\% \text{ on } 50\,000\text{-kva base.}$$

The impedance diagram Fig. 4(d) results, the percentages being shown as decimal fractions or “per unit” to facilitate computation.

In this case the current is:

$$I = \frac{1.0}{0.48} = 2.08 \text{ per unit or } 208 \text{ percent of the normal current, corresponding to the selected kva base.}$$

This normal current is:

$$I_n = \frac{50\,000}{\sqrt{3}(13.8 \text{ or } 110)} = 2090 \text{ amp. at } 13.8 \text{ kv or } 262 \text{ amp. at } 110 \text{ kv}$$

The generator and line currents are, therefore, 208 percent of 2090 and 262 or 4350 and 545 amperes respectively, which agree with the preceding calculations.

The base selected obviously is immaterial. Had a 100 000-kva base been used, the impedances in Fig. 4(d) would all be doubled and the resulting percent currents halved. But the normal currents to which these percentages refer would be twice as great, and thus the same number of amperes would be obtained.

8. Phase Shifts in Transformer Banks

In addition to magnitude transformation, the voltage of the reference phase in general undergoes a shift in angular position. For balanced conditions, that is, considering positive-sequence quantities only, this is generally of no significance. For example, in the problem just worked out, the current in the reference phase of the line may or may not have been in phase with the reference or *a* phase current in the generator. If the transformer were delta-delta, the currents would have been in-phase; if delta-star they would have been 30 degrees out-of-phase, using the usual conventions.

However, it should be recognized that an angular transformation has been made whenever the single-phase circuit or impedance diagram is used for the calculation of currents and voltages in a circuit including a star-delta connected transformer bank. The following statements should aid in determining the treatment required in any particular case.

Radial Systems—In radial systems, the angle transformation is not usually significant as few phenomena involve comparisons of the phase angles of line currents on opposite sides of a transformation. Since currents and voltages are shifted alike, power or impedance determination at any one point in the circuit is unaffected by the angle transformation.

Transformer Differential Protection—A typical exception is the differential protection of a transformer bank. Here the currents on opposite sides of the transformation are purposely compared and measures must be taken to correct for the shift if the devices used are sensitive to phase angle.

Sequence Voltages and Currents—Positive-sequence voltages and currents are shifted the same as the reference or *a* phase in progressing through a symmetrical transformation. Negative-sequence voltages and currents, if present, are shifted the same amount as the reference phase but in the reverse direction. Zero-sequence voltages and currents are not shifted in progressing through a transformation.

Ideal Transformation—The shifts referred to have to do with the ideal transformer only, deleted of all leakage impedance and exciting current. That is, they depend only on how many turns of primary and secondary are used on each core and how these are grouped to form the phases on the primary and secondary sides. Symmetry with respect to *a*, *b*, and *c* phases is assumed.

Regulating Transformers—A symmetrical three-phase bank of regulating transformers may involve both ratio and phase-angle transformation. Suppose that in progressing through a particular bank of this type, a phase-angle advance of 10 degrees exists in the reference phase. Then, in progressing through the transformer in the same direction, positive-sequence quantities (currents and voltages) are advanced 10 degrees, negative-sequence quantities retarded 10 degrees, and zero-sequence quantities not shifted at all.

Standard Angular Shifts—The angular shifts of reference phase for various transformer connections are given in Chap. 5, Sec. 13. The American Standard* is a 30-degree advance in phase in progressing through either a star-delta or a delta-star connected transformer from a lower to a higher voltage. When carried out consistently, this will permit interconnections at various system voltages without difficulty in phasing. However, at present practically all possible connections are in use throughout the industry.

9. Loop Systems That Close

Transformations of magnitude or angle in a system involving one or more loops can be treated similarly to a radial system provided that:

- The product of the magnitude transformation ratios for the reference phase, taken in a common direction around each closed loop is unity.
- The sum of the reference phase angular shifts taken in a common direction around each closed loop is zero.

If each transformation ratio is expressed vectorially as $N\epsilon^{j\theta}$, including angular significance in the term “vector transformation ratio,” then *a* and *b* above can be combined into the single requirement:

- The product of the vector transformation ratios around each closed loop is $1\epsilon^{j0}$.

If the requirements *a* and *b*, or *c* are fulfilled, then the circuits of the system can be divided into zones separated

*ASA Standards C-57.

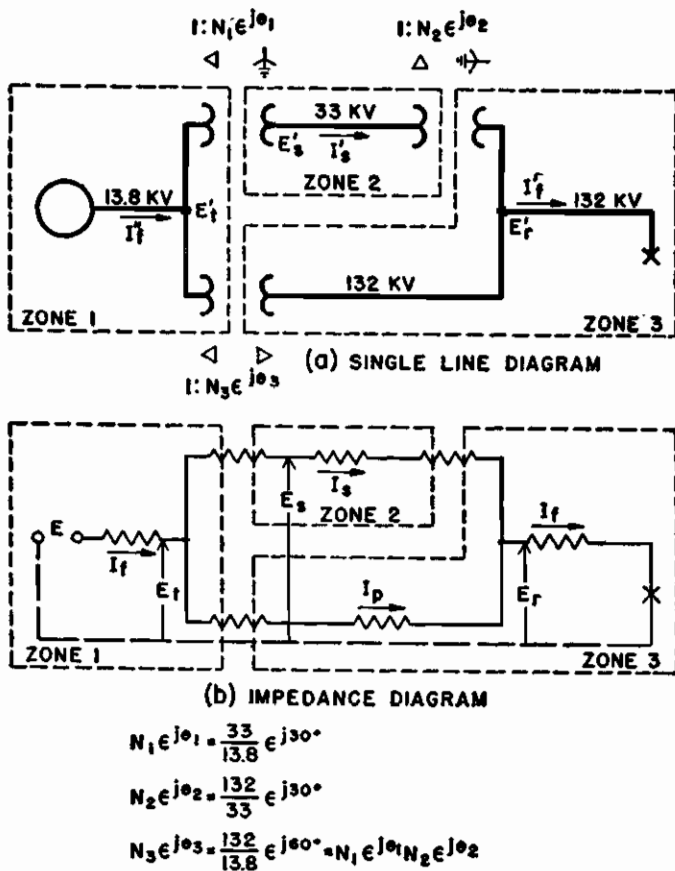

Fig. 5—Ratio and angular transformations.

from each other by transformations. One zone, usually the one of greatest interest in the particular problem, can be taken as the reference zone.

Example—For example, in Fig. 5 currents in various parts of the system are to be determined for a balanced three-phase fault on the 132-kv line.

There is one closed loop in which:

$$(N_1 e^{j\theta_1}) (N_2 e^{j\theta_2}) \left(\frac{1}{N_3 e^{j\theta_3}} \right) = \left(\frac{33}{13.8} e^{j30^\circ} \right) \left(\frac{132}{33} e^{j30^\circ} \right) \left(\frac{1}{132/13.8 e^{j60^\circ}} \right) = 1 e^{j0} \quad (13)$$

Therefore, the reference-phase impedance diagram can be prepared from the single-phase diagram without showing any transformations.

Let Zone 3 be taken as the reference zone and all impedances expressed in ohms on 132-kv base. The fault current, I_f , and the distribution of currents I_s and I_p are now readily determined. So also are the voltages throughout the network. It is recognized that in Zone 3 these are the actual reference phase currents and voltages. In Zones 1 and 2 they are the actual quantities transformed to the Zone 3 base, and hence, must be transformed to their own respective bases to obtain the actual quantities. Since they are all positive-sequence currents and voltages, that is, normal balanced three-phase quantities, the actual currents and voltages of the reference phase, which have been indicated on the single line diagram, are as follows:

In Zone 3

$$I_f' = I_f \quad (14)$$

$$E_r' = E_r \quad (15)$$

In Zone 2

$$I_s' = \frac{I_s N_2}{\epsilon^{j\theta_2}} = I_s N_2 \epsilon^{-j\theta_2} \quad (16)$$

$$E_s' = \frac{E_s}{N_2 \epsilon^{j\theta_2}} = \frac{E_s}{N_2} \epsilon^{-j\theta_2} \quad (17)$$

In Zone 1

$$I_t'' = \frac{I_t N_3}{\epsilon^{j\theta_3}} = I_t N_3 \epsilon^{-j\theta_3} \quad (18)$$

$$E_t' = \frac{E_t}{N_3 \epsilon^{j\theta_3}} = \frac{E_t}{N_3} \epsilon^{-j\theta_3} \quad (19)$$

The Zone 1 quantities may also be expressed as follows, illustrating the general method to be followed when the zone in question is separated from the reference zone by several transformations.

$$I_t'' = \frac{I_t N_1 N_2}{\epsilon^{j\theta_1} \times \epsilon^{j\theta_2}} = I_t N_1 N_2 \epsilon^{-j(\theta_1 + \theta_2)}$$

$$E_t' = \frac{E_t}{N_1 N_2 \epsilon^{j\theta_1} \times \epsilon^{j\theta_2}} = \frac{E_t}{N_1 N_2} \epsilon^{-j(\theta_1 + \theta_2)}$$

The power at any point s , for example, can be calculated without transforming. For:

$$P_s' + jQ_s' = E_s' I_s' = \left(\frac{E_s}{N_2} \epsilon^{-j\theta_2} \right) (I_s N_2 \epsilon^{+j\theta_2}) = E_s I_s \quad (20)$$

and

$$P_s + jQ_s = E_s I_s \quad (21)$$

These are the same. In other words the transformations described thus far and ordinarily used in analytical work are power invariant. They differ from transformations to a model scale for setting on a network calculator, in which power must obviously be scaled down.

10. Loop Systems That Do Not Close

If the product of vector transformation ratios around a closed loop is not unity, special consideration needs to be given. This case will be sub-divided into three parts, viz— (a) product of ratios not unity, (b) sum of angular shifts not zero, and (c) product of ratios not unity and sum of angles not zero.

Product of Ratios Not Unity—Many transformers are provided with taps in one or more windings. With star or delta connected windings, use of these taps changes the ratio only, without affecting the angular shift through the transformer. Thus, by far the largest number of cases of non-unity vector transformation ratio around closed loops falls in this category of ratio discrepancy only.

Example—An example is shown in Fig. 6, in which two circuits A and B differ in capacity, the taps having been increased on the B circuit to make it carry more of the load. The power factor of the portion of load that can be thus shifted from B to A depends on the impedance phase angles of the A and B circuits being nearly pure wattless for pure reactive circuits, and pure watts for pure resistive circuits. Thus, for 60 degrees impedance angle circuits the shifted

*See Section 2.

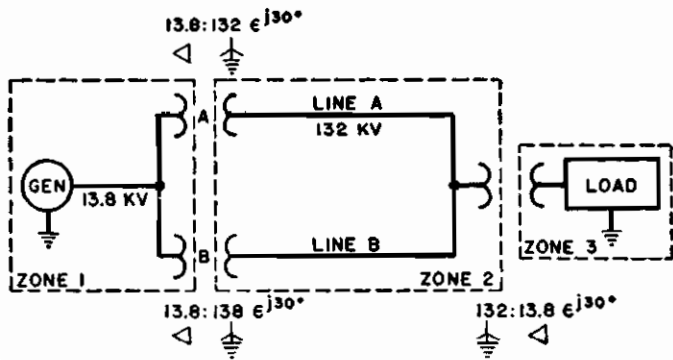

(a) SINGLE LINE DIAGRAM

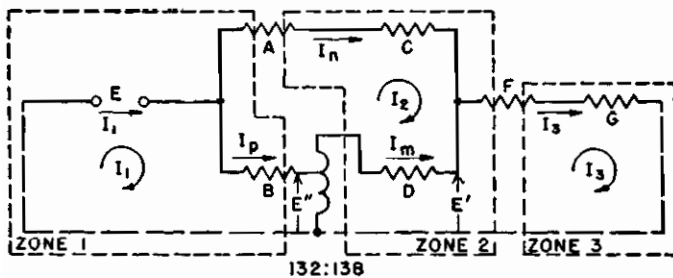

IDEAL AUTOTRANSFORMER

(b) IMPEDANCE DIAGRAM ON ZONE 2 BASE WITH REMNANT TRANSFORMATION INDICATED

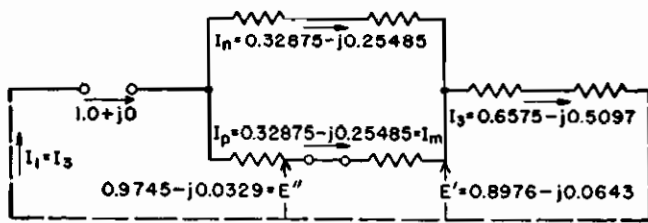

(c) CIRCUIT CALCULATED WITH SERIES EMF ZERO

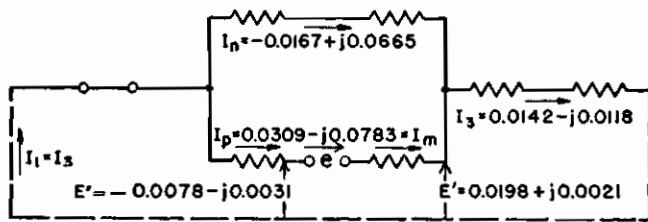

(d) CIRCUIT CALCULATED WITH SHUNT EMFS ZERO; SERIES EMF ACTING ALONE. $e = 0.0443 - j0.0015$

Fig. 6—Product of ratios around a closed loop not unity.

load is at about 50 percent power factor. The amount shifted is nearly constant, and not a percentage of the total load. Thus, at no load, there is a circulation over the two lines.

Suppose that the network of Fig. 6 is to be solved, and it is desired to work on the Zone 2 basis. Zone 3 can be readily transformed to this basis as explained in a preceding section. However, no transformation can be found for Zone 1 that will result in both transformer ratios being unity. The best that can be done is to make one of them,

for example A, unity by transforming the voltages of Zone 1 in the ratio $\frac{132}{13.8} e^{j30^\circ}$ and currents and impedances by

the corresponding factors. This leaves an uncompensated or remnant ratio to be accounted for in B, which may be represented as an autotransformer, Fig. 6(b).

In a-c network calculator studies, small auto-transformers of the remnant ratio are used and no further consideration need be given. For analytic studies the simplest method is to neglect the remnant transformation ratio, provided great accuracy is not required. The order of magnitude of the circulating current can be estimated by dividing the inserted voltage by the loop impedance to see whether it can be neglected in the problem at hand. For example, if the remnant ratio is 1.05 the inserted voltage is of the order of 0.05 per unit under normal load conditions. If the loop impedance is 0.50 per unit the order of magnitude of circulating current is $\frac{0.05}{0.50} = 0.10$ per unit.

If this cannot be neglected the following approximation is suggested in cases where the remnant ratio is close to unity. The accuracy of the method is indicated later by an example.

- a. Treat as though the ratio were unity and determine the resulting shunt voltage at the location of the auto-transformer.
- b. Determine the resulting series voltage introduced, in this case $\frac{138-132}{132} = \frac{6}{132} = 4.5$ percent of the shunt voltage, and in phase with it.
- c. Determine the current circulated in the network by the action of this series voltage alone, setting the generator emf, E , equal to zero. Determine the voltages for this condition also.
- d. Superpose this set of circulating currents on the currents previously calculated. Superpose the voltages similarly. The resulting solution is in error only by a correction factor of the second order which usually can be ignored, as will be shown subsequently.
- e. Where several such auto-transformers are required to "close" the impedance diagram, the circulating currents can be calculated separately, treating the ratios of the others as unity at the time. All of the resulting circulating currents can then be superposed. The resulting voltages can likewise be superposed.

This approximation is based on the concept that the auto-transformer could be replaced by a shunt load that draws the same current from the system as the main section of the auto-transformer and a series emf that impresses in series the same voltage as the short extension of the auto-transformer. With this substitution, the solution by superposition is exact. If the auto-transformer introduces five-percent voltage in series and the impedance to the resulting circulating current is 50 percent, then ten-percent current will flow. With five-percent voltage this amounts to 0.5-percent load, which is supplied from the system to the shunt winding of the auto-transformer, thence, to the series winding and back into the system, as I^2X and I^2R losses of circulation. As this load drawn by the shunt

winding is quite small, 0.5-percent in the case just cited, it is most frequently ignored.

In general, introduction of the series voltage raises the voltage on one side of the auto-transformer and lowers it on the other side, as compared with the voltage that would be present if the auto-transformer were not there. Thus, if the series voltage is five percent, the shunt voltage applied to the auto-transformer will differ by not over five percent from that calculated with the auto-transformer removed. A correction of five-percent in the shunt voltage would change the series voltage from five-percent to 4.75 percent. This small correction usually is not required. Thus, the steps as outlined from *a* to *d* above will usually be sufficiently accurate.

Example—A comparison of the exact solution (by equations—see Sec. 13) and the approximation in the case of Fig. 6 will illustrate the procedure and indicate the degree of accuracy to be expected. Assume a set of constants as follows, in per unit on the generator kva base. Assume the voltage to be maintained constant on the generator bus.

$$\begin{aligned}
 A &= j0.10 & E &= 1 + j0 \\
 B &= j0.10 \\
 C &= 0.10 + j0.173 \\
 D &= 0.10 + j0.173 \\
 F &= j0.10 \\
 G &= 0.90 + j0.50
 \end{aligned}$$

Following the steps suggested above, the series voltage is first set equal to zero and the solution using the generator voltage alone is obtained, Fig. 6(c). The series voltage is 4.5 percent of $0.9745 - j0.0329$ or equal to $0.0443 - j0.0015$ and is directed to the right. Then, setting the generator voltage equal to zero and applying the series voltage alone, the solution of Fig. 6(d) is obtained. Adding vectorially the corresponding quantities in these two solutions, the superposed solution, Fig. 7(a), is obtained for the simultaneous application of the generator voltage, *E*, and the

series voltage *e*, and is a good approximation to the exact solution of the circuit of Fig. 6(a) and (b) as will be shown by comparison with Fig. 7(b).

The Exact Solution for the currents and voltages in Fig. 6(b) can be obtained by writing Kirchoff's Law for the

TABLE 2—COMPARISON OF RESULTS BY APPROXIMATE AND EXACT METHODS OF SOLUTION WHEN PRODUCT OF VECTOR TRANSFORMATION RATIOS IS NOT UNITY. (REFER ALSO TO FIG. 7).

	By Approximate Method		By Exact Method		% Diff. = $\frac{\text{Exact}}{\text{Approx.}} - 100$
	Vector	Scalar	Vector	Scalar	
I_1	$0.672 - j0.522$	0.851	$0.686 - j0.536$	0.870	2.18
I_2	$0.672 - j0.522$	0.851	$0.670 - j0.521$	0.849	0.24
I_n	$0.312 - j0.188$	0.364	$0.316 - j0.191$	0.369	1.36
I_p	$0.360 - j0.333$	0.490	$0.371 - j0.345$	0.507	3.35
I_m	$0.360 - j0.333$	0.490	$0.355 - j0.330$	0.485	1.03
E''	$0.967 - j0.036$	0.968	$0.965 - j0.037$	0.966	0.21
E'	$0.917 - j0.066$	0.919	$0.916 - j0.067$	0.918	0.11

drops around each of the three loops and setting up a fourth equation stating that the total ampere-turns on the perfect transformer are zero.

$$I_1 B - I_2 B + I_3(0) + E'' = E \tag{22}$$

$$-I_1 B + I_2(A + B + C + D) - I_3 D + E''(0.045) = 0 \tag{23}$$

$$I_1(0) - I_3 D + I_2(D + F + G) - E''(1.045) = 0 \tag{24}$$

$$I_1 + I_2(0.045) - I_3(1.045) + E''(0) = 0 \tag{25}$$

The solution of these simultaneous equations with the numerical values of the impedances *A* to *G* substituted, is given in Fig. 7(b). Table 2 shows the error in various quantities by the approximate method. The voltages are within 0.2 percent. The largest current error is 3.35 percent in I_p . The sum of errors in I_p and I_m are about 4.5 percent. This is necessary since these two currents are taken the same in the approximate solution and differ by 4.5 percent in the exact solution.

Sum of Angular Shifts Not Zero—Regulating transformers or regulators as well as special connections of transformers can introduce angular shift. If the net shift around a closed loop is not zero but is small, the treatment is similar to that for ratio discrepancies except that the series voltage is introduced at right angles to the shunt voltage. On the a-c network calculator, transformers cannot be used to obtain a shift since the circuits are single phase. Power sources must be used to introduce the necessary series voltages.

Sum of Angular Shifts Not Zero and Sum of Ratios Not Unity—The series voltage can be introduced at any desired angle, corresponding to the net vector transformation ratio, and the currents superposed as outlined above, with appropriate phase relations.

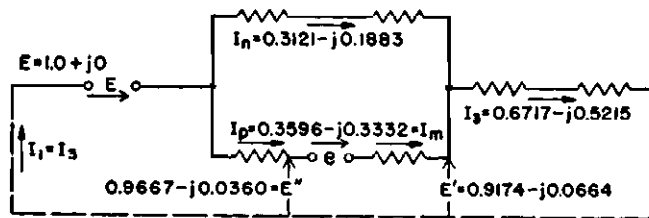

(a) APPROXIMATE SOLUTION OBTAINED BY SUPERIMPOSING THE RESULTS OF THE SHUNT AND SERIES EMF'S, FIG. 6 (c) AND (d)

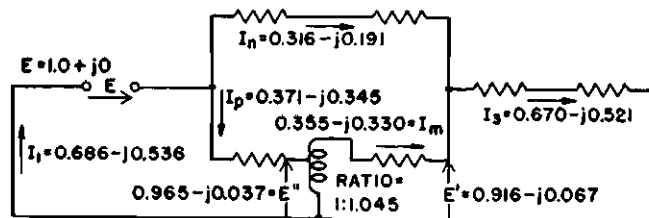

(b) EXACT SOLUTION BY SOLUTION OF THE EQUATIONS

Fig. 7—Comparison of exact and approximate solutions of Fig. 6.

II. NETWORK SOLUTION

11. Network Theorems**

The Superposition Theorem states that each emf produces currents in a linear network* independently of those produced by any other emf. It follows that the emfs and currents of a given frequency can be treated independently of those of any other frequency, and of transients. The superposition theorem is a direct result of the fact that the fundamental simultaneous differential equations of the network are linear. (See any standard book on Differential Equations.) (See Sec. 13.)

The Compensation Theorem states that if the impedance of a branch of a network be changed by an amount ΔZ , the change in current in any branch is the same as would be produced by a compensating emf $-\Delta Z I$, acting in series with the modified branch, I being the original current in that branch. By compensating emf is meant one which, if it were inserted, would neutralize the drop through ΔZ . This theorem follows directly from the superposition theorem.

The Reciprocal Theorem states that when a source of electromotive force is connected across one pair of terminals of a passive† linear network and an ammeter is connected across a second pair of terminals, then the source of electromotive force and the ammeter can be interchanged without altering the reading of the ammeter (provided neither the source nor receiver has internal impedance). This follows from the fact that in Eq. (56), if all emfs are zero except E_2 and E_3 for example, then if

$$E_2 = 0, \quad I_2 = \frac{E_3 A_{23}}{D}, \quad \text{while if } E_3 = 0, \quad I_3 = \frac{E_2 A_{32}}{D},$$

so that if $E_3 = E_2$, $I_3 = I_2$ for the conditions of the theorem. Note that $A_{23} = A_{32}$.

12. Reference Current and Voltage Directions

To specify uniquely a vector current or voltage in a circuit, some system must be adopted to label the points between which the voltage is being described or the branch in which the current flows. This system must also indicate the reference or positive direction. Two common methods are: the use of reference or positive direction arrows and the double subscript notation.

Reference Direction Arrows—Fig. 8(a) and (b)—When a network is to be solved to determine, for example, the current flow for a given set of impressed emfs, the network should first be marked with arrows to indicate the reference positive direction of each current and voltage involved. These can be drawn arbitrarily, although if the predominant directions are known, their use as reference-direction arrows simplifies later interpretation.

The use of open voltage-arrowheads and closed current-arrowheads will avoid confusion in numerical work, where the E and I symbols are not used.

It must be decided at this point whether the voltage

**See also Thevenin's Theorem, Sec. 18.

*A linear network is one in which each impedance is linear; that is, has a straight line relation between current and voltage drop.

†A passive network is one having no internal emfs as distinguished from an active network.

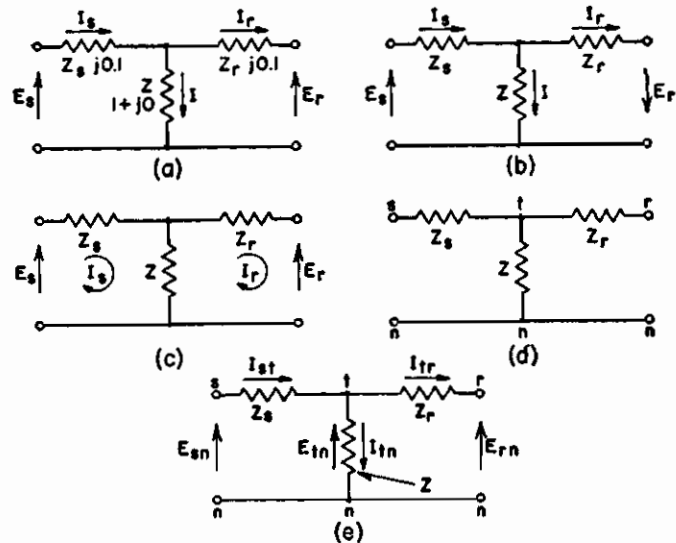

Fig. 8—Methods of notation used in network solution.

arrow is to represent a rise or a drop. In system calculations it is generally used as the rise in voltage. While this decision is arbitrary, once made, it must be adhered to consistently.

Finally a vector value must be assigned to the voltage or current. It can be expressed as a complex number, or in polar form or graphically and gives the magnitude and relative phase of the quantity with respect to some reference. A symbol, such as I_s , can be used to designate this vector quantity.

The known vectorial voltages or currents must be associated with the reference arrows in a manner consistent with the conditions of the problem. For example, suppose the problem in Fig. 8(a), is to determine the currents that would flow with the two voltage sources 180 degrees out of phase, and 100 volts each, rms, 60-cycle. Then if E_s is taken as $100 + j0$, E_r must be taken as $-100 + j0$. Had the arbitrary reference-direction arrows been taken as in Fig. 8(b), then for the same problem a consistent set of voltages would be:

$$E_s = 100 + j0, \quad E_r = 100 + j0$$

Ordinarily the reference-direction arrows for shunt voltages are directed from the neutral to the phase conductor as in Fig. 8(a).

Summarizing then, the complete specification of a quantity in the reference-direction-arrow system involves three elements:

- The reference-direction arrow, drawn arbitrarily.
- An agreement, consistently followed as to what the reference-direction arrow means; particularly whether the voltage arrow means the voltage of the point above the tail or the drop from tail to point.
- A vector to represent the magnitude and relative phase of the quantity with respect to a reference.

Suggested convention: For voltages, the vector quantity shall indicate the voltage of the point of the arrow above the tail, that is, the rise in the direction of the arrow. It then is also the drop from point to tail.

Mesh Currents and Voltages—Refer to Fig. 8(c)—The “mesh current” system involves a somewhat different point of view. Here each current is continuous around a mesh and several currents may flow in the same branch. (I_s and I_r flow in Z .) The branch current is the vector sum of all the mesh currents in the branch, taken in the reference direction for the branch current. If such a network can be laid out “flat,” it is most convenient to take the reference direction for mesh currents as simply “clockwise” for example. Or circular arrows can be used as shown in Fig. 8(c). The example of solution by equations in Sec. 9 illustrates the use of “mesh currents.”

The same reference directions can be conveniently used for mesh emfs, which are the vector sum of all emfs acting around a particular mesh, taken in the reference direction.

Double-Subscript Notation—Fig. 8(d)—A double-subscript notation is sometimes used and is of course equivalent to the drawing of reference arrows. Here again an arbitrary decision must be made as to what is intended. Suggested Convention: Refer to Fig. 8(d).

I_{st} means the current from s to t .
 E_{sn} means the voltage of s above n

It is apparent then that $E_{ns} = -E_{sn}$; $I_{st} = -I_{ts}$, etc.

Setting Up Equations—If the work is analytical, by the method of equations, the equations must be set up consistent with the reference direction arrows, regardless of the values of any known currents or voltages. Consistent equations for Figs. 8(a), (b), (c), (d), are as follows, using Kirchoff's Laws (See Sec. 1): The voltage equations are written on the basis of adding all of the voltage rises in a clockwise direction around each mesh. The total must of course be zero. The current equations are written on the basis that the total of all the currents flowing up to a point must equal zero. Arrows and double subscripts have the meanings given in the “suggestions” above.

Referring to Fig. 8(a).

$$E_s - I_s Z_s - IZ = 0 \tag{26}$$

$$-I_r Z_r - E_r + IZ = 0 \tag{27}$$

$$I_s - I - I_r = 0 \tag{28}$$

Referring to Fig. 8(b).

$$E_s - I_s Z_s - IZ = 0 \tag{29}$$

$$-I_r Z_r + E_r + IZ = 0 \tag{30}$$

$$I_s - I - I_r = 0 \tag{31}$$

Referring to Fig. 8(c).

$$E_s - I_s(Z_s + Z) + I_r Z = 0 \tag{32}$$

$$I_s Z - I_r(Z + Z_r) - E_r = 0 \tag{33}$$

Referring to Fig. 8(d) or 8(e).

$$E_{sn} - I_{st} Z_s - I_{tn} Z = 0 \tag{34}$$

$$I_{tn} Z - I_{tr} Z_r - E_{rn} = 0 \tag{35}$$

$$I_{st} - I_{tn} - I_{tr} = 0 \tag{36}$$

In the double-subscript system, the voltages and currents could of course be indicated on the figure. They have been purposely omitted in Fig. 8(d), however, to emphasize that the specification of these quantities in Eqs. (34) and (35) is perfectly definite from the subscripts alone.

Also, the inclusion of reference-direction arrows on the diagram, even when the double-subscript system is used, may aid in writing equations, although they are not strictly required. If used, they must be consistent with the double-subscript system. That is, each arrow must be directed from the second subscript toward the first for voltages, and from the first subscript toward the second for currents. Fig. 8(e) illustrates such a diagram consistently labeled.

13. Solution by Equations

Representation—A network of n meshes can be represented as having n independent currents, I_1 to I_n , as shown in Fig. 9. The branch currents are combinations of these. See *Branch Currents* below.

Mesh Impedances are defined generally as: Z_{pq} = voltage drop in the reference direction in mesh q per unit of current in reference direction in mesh p . The curved arrows indicate reference directions in each mesh. In general

$$Z_{pq} = Z_{qp}$$

The impedances Z_{pp} and Z_{pq} are called self and mutual impedances.

Specifically in Fig. 9.

(First subscripts i and c indicate inductive and capacitive reactances respectively.)

$$Z_{11} = R_a + R_b + j(X_{ia} + X_{ib} - X_{ca} - X_{cb}) \tag{37}$$

$$Z_{12} = -R_b - j(X_{ib} - X_{cb}) \tag{38}$$

$$Z_{13} = 0 \tag{39}$$

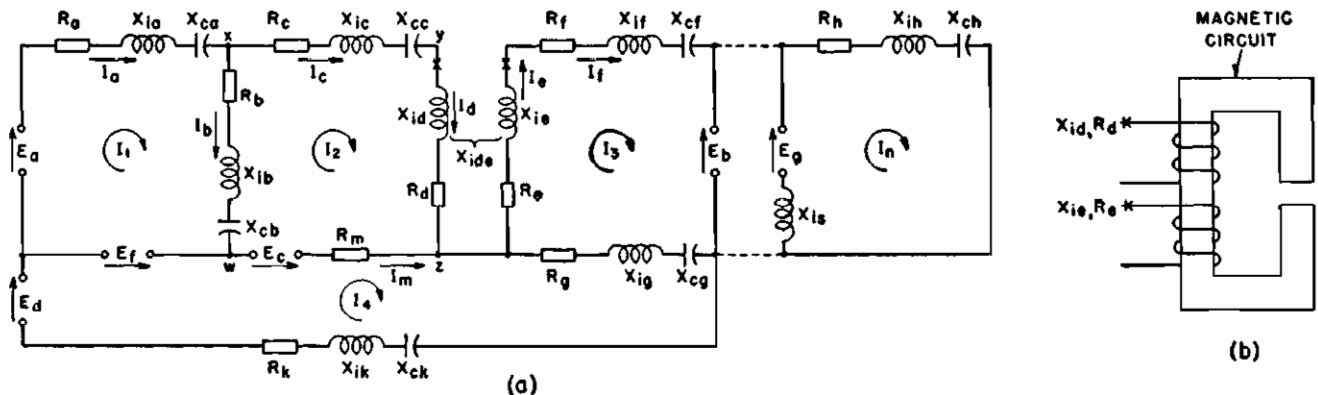

Fig. 9—General flat network.

$$Z_{14} = 0 \quad (40)$$

Etc.

$$Z_{22} = R_b + R_o + R_d + R_m + j(X_{ib} + X_{io} + X_{id} - X_{ob} - X_{oc}) \quad (41)$$

$$Z_{23} = -jX_{id} \quad (42)$$

[The polarity marks signify that the mutual flux links the two windings in a manner to produce maximum voltages at the same instant at the marked ends of the windings. See Fig. 9(b).]

$$Z_{24} = -R_m \quad (43)$$

$$Z_{25} = 0, \text{ etc.} \quad (44)$$

$$Z_{12} = Z_{21} \quad (45)$$

$$Z_{13} = Z_{31} \text{ etc.} \quad (46)$$

Mesh Emfs—Reference-positive directions for branch emfs, E_a , E_b , etc., are shown by arrows associated therewith.

A mesh emf is the sum of the branch emfs acting around that particular mesh in the reference direction.

The same reference direction will be used for mesh emfs as for mesh currents.

Specifically in Fig. 9.

$$E_1 = E_a - E_t \quad (47)$$

$$E_2 = -E_o \quad (48)$$

$$E_3 = -E_b \quad (49)$$

$$E_4 = E_d + E_t + E_o \quad (50)$$

Etc.

$$E_n = E_g \quad (51)$$

Equations—Kirchoff's Law states that the voltage drop around each closed mesh must equal the emf impressed in that mesh.

$$I_1 Z_{11} + I_2 Z_{21} + I_3 Z_{31} + \cdots + I_n Z_{n1} = E_1 \quad (52)$$

$$I_1 Z_{12} + I_2 Z_{22} + I_3 Z_{32} + \cdots + I_n Z_{n2} = E_2 \quad (53)$$

$$I_1 Z_{13} + I_2 Z_{23} + I_3 Z_{33} + \cdots + I_n Z_{n3} = E_3 \quad (54)$$

$$\begin{array}{ccccccc} \cdot & \cdot & \cdot & \cdot & \cdot & \cdot & \cdot \\ \cdot & \cdot & \cdot & \cdot & \cdot & \cdot & \cdot \\ \cdot & \cdot & \cdot & \cdot & \cdot & \cdot & \cdot \\ \cdot & \cdot & \cdot & \cdot & \cdot & \cdot & \cdot \end{array}$$

$$I_1 Z_{1n} + I_2 Z_{2n} + I_3 Z_{3n} + \cdots + I_n Z_{nn} = E_n \quad (55)$$

Mesh Currents*—Equations (52) to (55) can be solved for the mesh currents I_1 to I_n . The solution for current in any particular mesh, p , is:

$$I_p = \frac{E_1 A_{p1}}{D} + \frac{E_2 A_{p2}}{D} + \frac{E_3 A_{p3}}{D} + \cdots + \frac{E_n A_{pn}}{D} \quad (56)$$

where D is the determinant of coefficients

$$D = \begin{vmatrix} Z_{11}Z_{21}Z_{31} \cdots Z_{n1} \\ Z_{12}Z_{22}Z_{32} \cdots Z_{n2} \\ Z_{13}Z_{23}Z_{33} \cdots Z_{n3} \\ \cdot & \cdot & \cdot & \cdot & \cdot \\ \cdot & \cdot & \cdot & \cdot & \cdot \\ \cdot & \cdot & \cdot & \cdot & \cdot \\ Z_{1n}Z_{2n}Z_{3n} \cdots Z_{nn} \end{vmatrix} \quad (57)$$

and A_{pq} is the cofactor of Z_{pq} in the determinant (57).

*The method of determinants is used to state the solution here. However, any method of solving the simultaneous equations (52) to (55) for the unknown currents I_1 to I_n may be used.

The cofactor of a term in a determinant is the minor determinant obtained by eliminating the row and column containing that term, this minor being prefixed by a + or - sign depending on whether the sum of column number and row number is even or odd respectively. In (57), the first subscripts define columns, the second rows. Thus the cofactor of a term has a + sign if the sum of subscripts on the term is even. Since $Z_{pq} = Z_{qp}$, it can be shown that $A_{pq} = A_{qp}$.

In (56), the term involving E_1 is the current that flows in mesh p if all emfs are set equal to zero except E_1 . Similarly, the term $\frac{E_2 A_{p2}}{D}$ is the current that flows in mesh p if E_2 alone acts and E_1, E_3 , etc., are equal to zero.

Specifically:

$$I_2 = \frac{E_1 A_{21}}{D} + \frac{E_2 A_{22}}{D} + \frac{E_3 A_{23}}{D} + \cdots + \frac{E_n A_{2n}}{D} \quad (58)$$

where D is given by (57).

And:

$$A_{21} = - \begin{vmatrix} Z_{12}Z_{32} \cdots Z_{n2} \\ Z_{13}Z_{33} \cdots Z_{n3} \\ \cdot & \cdot & \cdot \\ \cdot & \cdot & \cdot \\ Z_{1n}Z_{3n} \cdots Z_{nn} \end{vmatrix} \quad (59)$$

$$A_{22} = + \begin{vmatrix} Z_{11}Z_{31} \cdots Z_{n1} \\ Z_{13}Z_{33} \cdots Z_{n3} \\ \cdot & \cdot & \cdot \\ \cdot & \cdot & \cdot \\ Z_{1n}Z_{3n} \cdots Z_{nn} \end{vmatrix} \quad (60)$$

$$A_{23} = - \begin{vmatrix} Z_{11}Z_{31} \cdots Z_{n1} \\ Z_{12}Z_{32} \cdots Z_{n2} \\ \cdot & \cdot & \cdot \\ \cdot & \cdot & \cdot \\ Z_{1n}Z_{3n} \cdots Z_{nn} \end{vmatrix} \text{ Etc.} \quad (61)$$

Branch Currents can now be obtained by combination. The vector sum of all mesh currents flowing in a branch is the branch current.

Specifically with reference to Fig. 9.

$$I_a = I_1 \quad (62)$$

$$I_b = I_1 - I_2 \quad (63)$$

$$I_c = I_2 \quad (64)$$

$$I_m = I_4 - I_2 \quad (65)$$

Etc.

Branch Voltages—The branch voltages, E_{yx} , E_{yx} , etc., or the voltages between any two conductively connected points in the network, as E_{xx} , can be obtained by vectorial addition of all voltages, both emfs and drops through any path connecting the two points.

The voltage drop from x to y , D_{xy} , and the voltage of point x above point y , E_{xy} , are the same.

(Note that drop is measured from first subscript to second. The voltage of the first subscript is measured above the second.)

$$D_{xy} = E_{xy} = I_c R_c + jI_c(X_{ic} - X_{cc}) \quad (66)$$

$$D_{yz} = E_{yz} = I_d R_d + jI_d X_{id} - jI_e X_{id} \quad (67)$$

$$D_{wz} = E_{wz} = -E_c + I_m R_m \quad (68)$$

$$D_{xz} = E_{xz} = I_c R_c + jI_c(X_{ic} - X_{cc}) + I_d R_d + jI_d X_{id} - jI_e X_{id} \quad (69)$$

Note that

$$D_{xz} = D_{xy} + D_{yz} \quad (70)$$

$$E_{xz} = E_{yz} + E_{xy} \quad (71)$$

Example of Solution by Equations—(a) Given the impedances and emfs of a network, Fig. 10, required to

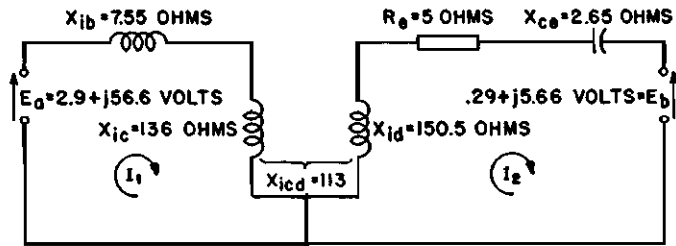

Fig. 10—Example of a solution by equations.

find the currents. Note: The headings (b), (c), etc., refer to the corresponding paragraphs b, c, etc., in which the method and equations are given.

(b) Mesh Impedances

$$Z_{11} = 0 + j(7.55 + 136) = 0 + j143.55$$

$$Z_{12} = Z_{21} = -j113.0$$

$$Z_{22} = 5 + j(150.5 - 2.65) = 5 + j147.85$$

(c) Mesh Emfs

$$E_1 = 2.9 + j56.6$$

$$E_2 = -0.29 - j5.66$$

(d) Equations. It is unnecessary to write these out completely since only the solutions are desired. However for completeness they are:

$$I_1(0 + j143.55) + I_2(-j113.0) = 2.9 + j56.6$$

$$I_1(-j113.0) + I_2(5 + j147.85) = -0.29 - j5.66$$

(e) Mesh Currents

$$D = \begin{vmatrix} 0 + j143.6 & -j113.0 \\ -j113.0 & 5 + j147.9 \end{vmatrix} = -8400 + j718$$

$$A_{11} = 5 + j147.9$$

$$A_{12} = A_{21} = +j113$$

$$A_{22} = 0 + j143.6$$

$$I_1 = \frac{E_1 A_{11} + E_2 A_{12}}{D} + \frac{E_2 A_{22}}{D}$$

$$= \frac{(2.9 + j56.6)(5 + j147.9) + (-0.29 - j5.66)(j113)}{-8400 + j718} + \frac{(-0.29 - j5.66)(j113)}{-8400 + j718}$$

$$= 0.921 + j0.007$$

$$I_2 = \frac{E_1 A_{21} + E_2 A_{22}}{D} + \frac{E_2 A_{12}}{D}$$

$$= \frac{(2.9 + j56.6)(j113) + (-0.29 - j5.66)(+j143.6)}{-8400 + j718} + \frac{(-0.29 - j5.66)(+j143.6)}{-8400 + j718}$$

$$= 0.662 + j0.034$$

Note that the term $\frac{A_{12}}{D} = \frac{A_{21}}{D}$ is the "transfer admittance" between meshes 1 and 2, or is the current in either

one of these meshes per unit of emf impressed in the other. Thus the voltage E_2 is -0.1 of E_1 and likewise the current in mesh 1 resulting from E_2 is -0.1 of the current in mesh 2 due to E_1 .

14. Solution by Reduction

General—The currents flowing in a network of known impedances, caused by a given set of applied emfs, can be determined by the method of superposition (See Sec. 11). First the solution (currents in all branches of interest) is obtained considering one emf acting with all others set equal to zero. Following the same procedure for each emf in turn, a number of current solutions are obtained. By the principle of superposition, the current in any branch, when all emfs are acting at once, is the sum of currents in that branch caused by each emf acting independently with the others set equal to zero. The principle of superposition presupposes a linear network. The same reference directions must be adhered to for all solutions if the superposition is to be a simple vector addition of the several current solutions.

The solving of a network involving several emfs is thus reduced to the more fundamental problem of solving a network with one impressed emf. This can be accomplished by the method of reduction.

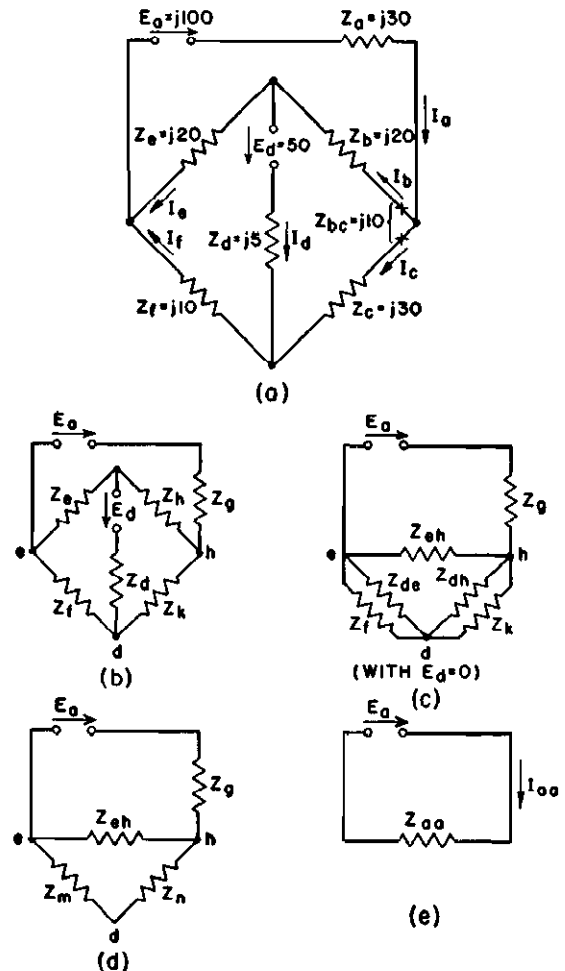

Fig. 11—Solution by reduction. Bridge network current distribution.

Solution by Reduction consists of replacing portions of network, such as Fig. 11(a), by simpler equivalent sections, Fig. 11(b, c, d), until a simple series circuit results, Fig. 11(e), which includes the impressed emf and one impedance branch. The current is readily calculated. Then, using current distribution factors obtained in the course of reduction, a reverse process is carried out, expanding the network to its original form and determining the division of currents in the process. The methods and equivalent circuits for carrying out this procedure in general are given in the subsequent paragraphs.

The Network Equivalents will first be given. Network constants can be expressed either in admittance or impedance form. Some transformations are more readily performed in impedance form, such as adding impedances in series, or delta-to-star transformations. Others are more conveniently performed in admittance form, such as adding admittances in parallel, or star-to-delta transformations. For more complicated transformations, it is best to convert constants to the most convenient form for the particular transformation. For simpler ones, it is usually preferred to use one form or the other throughout the problem.

The common transformations are presented in both forms. The more complicated and unusual ones only in the form best suited. Impedances (symbol Z) are reciprocals of admittances (symbol Y) and vice versa. That is

$$Z_1 = \frac{1}{Y_1} \tag{72}$$

$$Y_1 = \frac{1}{Z_1} \tag{73}$$

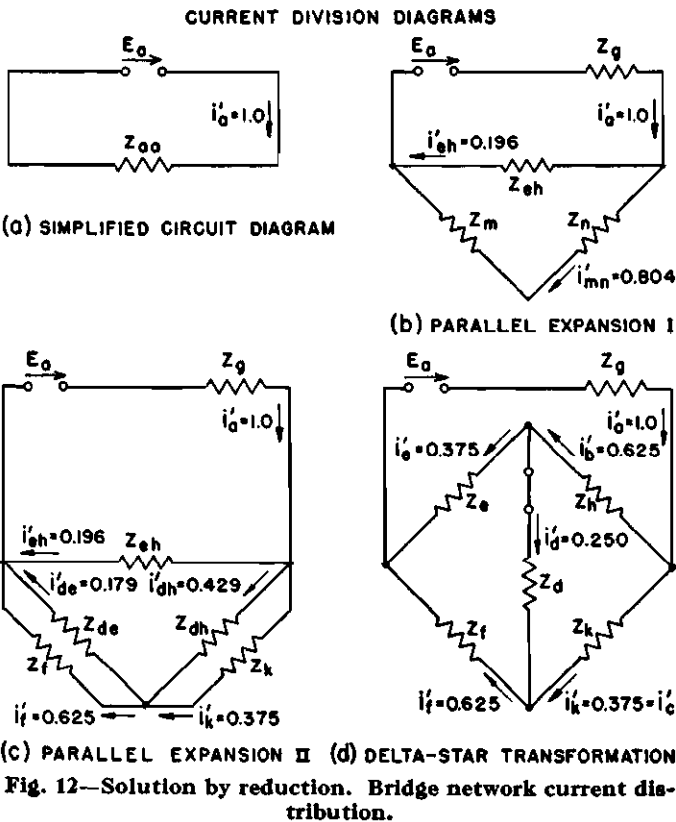

Fig. 12—Solution by reduction. Bridge network current distribution.

In all cases, the equivalent circuits are equivalent only insofar as the labeled terminals are concerned. For example, when a star with mutuals is reduced to a star without mutuals, the potential of the center point is not the same in the equivalent.

Delta and star forms used in general networks are identical with Pi and T forms used in specialized transmission forms of networks. See Fig. 15. The difference is simply in the manner of drawing the circuit. Thus the star-delta and delta-star transformations are at once, T to Pi and Pi to T transformations. The arrow between parts of the figures indicates that the figure on the left is being transformed to the figure on the right. It is assumed then that the currents are determined for the figure on the right and the equations under the figure on the left are for determining the resulting currents (or voltages) in it.

15. Transformations in Impedance Form

a. Impedances in Series (Fig. 13)

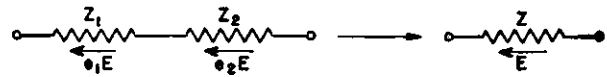

Fig. 13—Impedances in series.

$$e_1 = \frac{Z_1}{Z_1 + Z_2} = \frac{Z_1}{Z} \tag{75} \quad Z = Z_1 + Z_2 \tag{74}$$

$$e_2 = \frac{Z_2}{Z_1 + Z_2} = \frac{Z_2}{Z} \tag{76}$$

b. Impedances in Parallel (Fig. 14)—“The parallel of two impedances is the product divided by the sum.”

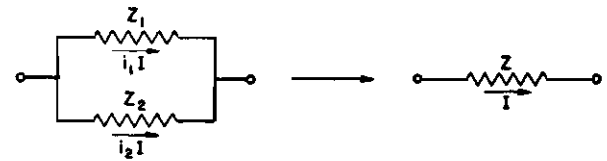

Fig. 14—Impedances in parallel.

$$i_1 = \frac{Z_2}{Z_1 + Z_2} \tag{78} \quad Z = \frac{Z_1 Z_2}{Z_1 + Z_2} \tag{77}$$

$$i_2 = \frac{Z_1}{Z_1 + Z_2} \tag{79}$$

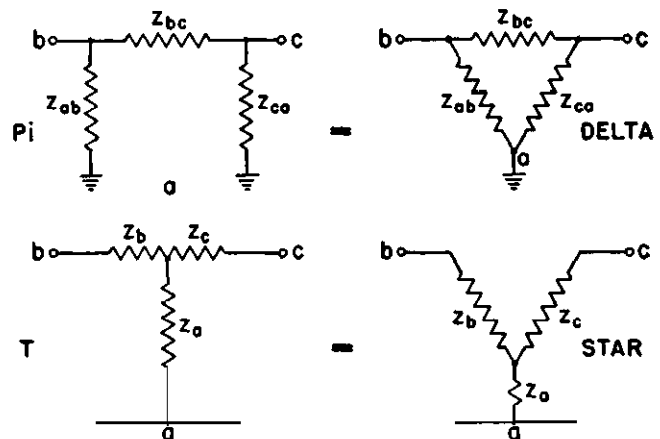

Fig. 15—Pi and delta; T and stars or Y are the same.

Suggested order of calculation (80)

$$D = Z_1 + Z_2$$

$$i_1 = \frac{Z_2}{D} = \text{current in } Z_1 \text{ per unit current in } Z. \quad (81)$$

$$i_2 = 1 - i_1 = \text{current in } Z_2 \text{ per unit current in } Z. \quad (82)$$

(i_1 and i_2 are current distribution factors.)

$$Z = i_1 Z_1 \quad (83)$$

c. Delta to Star Transformation or Pi to T (Fig. 16)—"The star impedances are the product of adjacent delta impedances divided by the sum of all delta impedances."

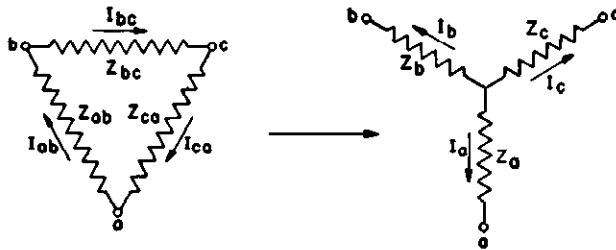

Fig. 16—Delta to star—impedance form.

$$I_{ab} = -\frac{Z_{ca}}{D} I_a + \frac{Z_{bc}}{D} I_b \quad (88a) \quad Z_a = \frac{Z_{ca} Z_{ab}}{D} \quad (84)$$

$$= -i_{ca} I_a + i_{bc} I_b \quad (88b)$$

$$I_{bc} = -\frac{Z_{ab}}{D} I_b + \frac{Z_{ca}}{D} I_c \quad (89a) \quad Z_b = \frac{Z_{ab} Z_{bc}}{D} \quad (85)$$

$$= -i_{ab} I_b + i_{ca} I_c \quad (89b)$$

$$I_{ca} = -\frac{Z_{bc}}{D} I_c + \frac{Z_{ab}}{D} I_a \quad (90a) \quad Z_c = \frac{Z_{bc} Z_{ca}}{D} \quad (86)$$

$$= -i_{bc} I_c + i_{ab} I_a \quad (90b) \quad D = Z_{ab} + Z_{bc} + Z_{ca} \quad (87)$$

Suggested order of calculation*

$$D = Z_{ab} + Z_{bc} + Z_{ca} \quad (87)$$

$$i_{ab} = \frac{Z_{bc}}{D} \quad (91)$$

$$Z_a = Z_{ca} i_{ab} \quad (92)$$

$$i_{bc} = \frac{Z_{ca}}{D} \quad (93)$$

$$Z_b = Z_{ab} i_{bc} \quad (94)$$

$$i_{ca} = \frac{Z_{ab}}{D} \quad (95)$$

$$Z_c = Z_{bc} i_{ca} \quad (96)$$

(i_{ab} , i_{bc} , i_{ca} are current distribution factors.)

d. Star to Delta Transformation or T to Pi (Fig. 17)

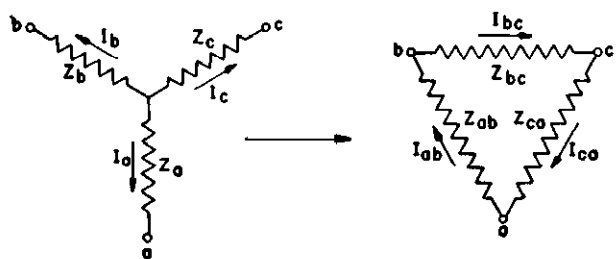

Fig. 17—Star to delta—impedance form.

*Then after I_a , I_b , and I_c have been found, I_{ca} , I_{ab} , and I_{bc} can be determined using Eqs. (88b), (89b), and (90b).

$$I_a = I_{ca} - I_{ab} \quad (101) \quad Z_{ab} = D Z_a Z_b \quad (97)$$

$$I_b = I_{ab} - I_{bc} \quad (102) \quad Z_{bc} = D Z_b Z_c \quad (98)$$

$$I_c = I_{bc} - I_{ca} \quad (103) \quad Z_{ca} = D Z_c Z_a \quad (99)$$

$$D = \frac{1}{Z_a} + \frac{1}{Z_b} + \frac{1}{Z_c} \quad (100)$$

Alternative forms of the transformation formulas follows:

$$\text{Num.} = Z_a Z_b + Z_a Z_c + Z_b Z_c \quad (104)$$

$$Z_{ab} = \frac{\text{Num.}}{Z_c} = Z_a + Z_b + \frac{Z_a Z_b}{Z_c} \quad (105)$$

$$Z_{bc} = \frac{\text{Num.}}{Z_a} = Z_b + Z_c + \frac{Z_b Z_c}{Z_a} \quad (106)$$

$$Z_{ca} = \frac{\text{Num.}}{Z_b} = Z_c + Z_a + \frac{Z_c Z_a}{Z_b} \quad (107)$$

e. Star with Mutuals to Star without Mutuals (Fig. 18)

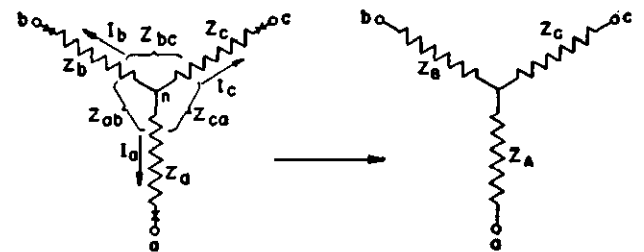

Fig. 18—Star with mutuals to star without mutuals—impedance form.

$$Z_A = Z_a + Z_{bc} - Z_{ab} - Z_{ca} \quad (108)$$

$$Z_B = Z_b + Z_{ca} - Z_{bc} - Z_{ab} \quad (109)$$

$$Z_C = Z_c + Z_{ab} - Z_{ca} - Z_{bc} \quad (110)$$

Polarity marks require that with all reference directions from center outward as shown, all self and mutual drops are from center outward. That is, it is understood that with the polarity marks as shown, the voltage drop from the center to a will be written:

$$D_{na} = I_a Z_a + I_b Z_{ab} + I_c Z_{ca}$$

and the numerical (vector) values and signs assigned to Z_{ab} and Z_{ac} must be such as to make this true. It follows that Z_{ab} is defined as the voltage drop from n to a divided by the current from n to b that causes the drop.

Special case: Star with one mutual between two branches to star without mutual. (Fig. 19.)

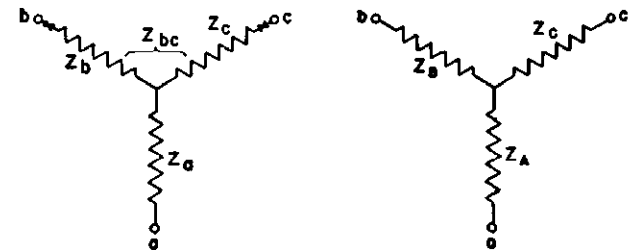

Fig. 19—Star with one mutual to star without mutual—impedance form.

$$Z_A = Z_a + Z_{bc} \quad (111)$$

$$Z_B = Z_b - Z_{bc} \quad (112)$$

$$Z_C = Z_c - Z_{bc} \quad (113)$$

f. Two Self Impedances and a Mutual Transformed to an Equivalent Star or T. Or the Equivalent Circuit of a Two-winding Transformer (Fig. 20)

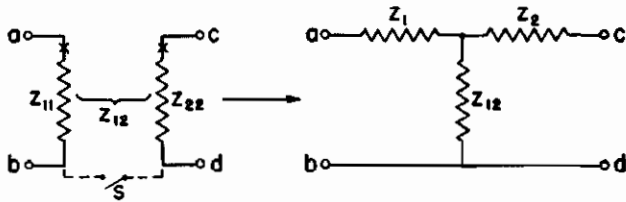

Fig. 20—Two self impedances and a mutual transformed to an equivalent star or T. Or the equivalent circuit of a two winding transformer.

$$Z_1 = Z_{11} - Z_{12} \quad (114)$$

$$Z_2 = Z_{22} - Z_{12} \quad (115)$$

NOTE: This transformation involves bringing *b* and *d* to the same potential and is permissible only when these potentials are not otherwise fixed. Strictly, the form on the right is equivalent to that on the left with switch *S* closed. However, if the closure of *S* would not alter the current division, it can be considered closed and the equivalent circuit used. The resulting potentials *E_{ab}*, and *E_{cd}* will be correct but the potentials *E_{ca}* and *E_{db}*, which are definite in the equivalent, are actually indeterminate in the original circuit and must not be construed as applying there. See note under *e* for meaning of polarity marks, considering *b* and *d* as point *n*.

This is the familiar equivalent circuit of a two-winding transformer, provided all impedances have first been placed on a common turns basis. In this case *Z₁₂* is the exciting impedance and *Z = Z₁ + Z₂* the leakage impedance.

16. Transformations in Admittance Form

a. Admittances in Series (Fig. 21)

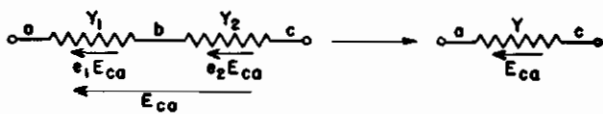

Fig. 21—Admittances in series.

$$e_1 = \frac{Y_2}{Y_1 + Y_2} \quad (117) \quad Y = \frac{Y_1 Y_2}{Y_1 + Y_2} \quad (116)$$

$$e_2 = \frac{Y_1}{Y_1 + Y_2} \quad (118)$$

Suggested order of calculation.

$$D = Y_1 + Y_2 \quad (119)$$

$$e_1 = \frac{Y_2}{D} \quad (120)$$

$$e_2 = 1 - e_1 \quad (121)$$

$$Y = Y_1 e_1, \text{ or } Y_2 e_2 \quad (122)$$

b. Admittances in Parallel (Fig. 22)

$$i_1 = \frac{Y_1}{Y_1 + Y_2} = \frac{Y_1}{Y} \quad (124)$$

$$Y = Y_1 + Y_2 \quad (123)$$

$$i_2 = \frac{Y_2}{Y_1 + Y_2} = \frac{Y_2}{Y} \quad (125)$$



Fig. 22—Admittances in parallel.

c. General Star to Mesh Transformation, or "Elimination of a Junction" (Fig. 23)

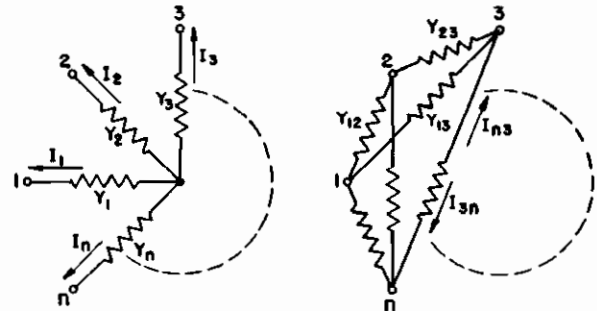

Fig. 23—General star to mesh transformation, or elimination of a junction—admittance form.

NOTE: A network can be solved by eliminating one junction point after another until a single-branch mesh remains.

RULE: "A mesh branch is the product of adjacent star branches divided by the sum of all star branches."

The mesh contains *n*/2 (*n* - 1) branches, where *n* is the number of star branches.

$$I_1 = I_{21} + I_{31} + \dots + I_{n1} \quad (130) \quad Y_{12} = \frac{Y_1 Y_2}{D} \quad (126)$$

$$I_2 = I_{12} + I_{32} + \dots + I_{n2} \quad (131) \quad Y_{13} = \frac{Y_1 Y_3}{D} \quad (127)$$

etc. etc.

$$I_p = I_{1p} + I_{2p} + \dots + I_{np} \quad (132) \quad Y_{pq} = \frac{Y_p Y_q}{D} \quad (128)$$

$$D = Y_1 + Y_2 + Y_3 + \dots + Y_n \quad (129)$$

In which the positive reference direction for any mesh current *I_{pq}* is toward terminal *q*.

Suggested order of calculation.

$$D = Y_1 + Y_2 + Y_3 + \dots + Y_n \quad (133) \quad \frac{Y_2}{D} = k_2 \quad (137)$$

$$\frac{Y_1}{D} = k_1 \quad (134) \quad Y_{23} = \frac{Y_2 Y_3}{D} = k_2 Y_3 \quad (138)$$

$$Y_{12} = \frac{Y_1 Y_2}{D} = k_1 Y_2 \quad (135) \quad Y_{24} = \frac{Y_2 Y_4}{D} = k_2 Y_4 \quad (139)$$

$$Y_{13} = \frac{Y_1 Y_3}{D} = k_1 Y_3 \quad (136) \quad \text{etc.}$$

etc.

d. Star to Delta or T to Pi (Special case of c) (Fig. 24)

$$I_a = I_{ca} - I_{ab} \quad (144) \quad Y_{ab} = \frac{Y_a Y_b}{D} \quad (140)$$

$$I_b = I_{ab} - I_{bo} \quad (145) \quad Y_{bo} = \frac{Y_b Y_o}{D} \quad (141)$$

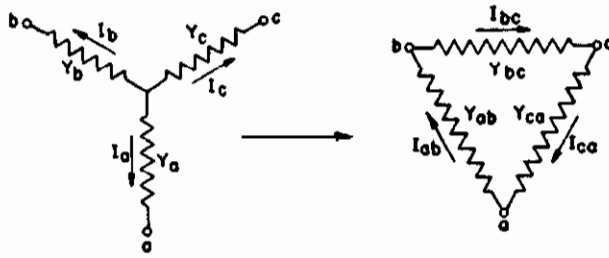

Fig. 24—Star to delta—admittance form.

$$I_o = I_{bo} - I_{co} \quad (146) \quad Y_{ca} = \frac{Y_c Y_a}{D} \quad (142)$$

$$D = Y_a + Y_b + Y_c \quad (143)$$

Suggested order of calculation same as for general transformation. (c)

e. Delta to Star Transformation, or Pi to T (Fig. 25)

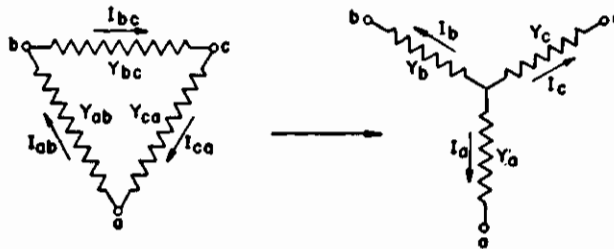

Fig. 25—Delta to star—admittance form.

$$I_{ab} = -i_{ca}I_a + i_{bc}I_b \quad (151) \quad Y_a = DY_{ca}Y_{ab} \quad (147)$$

$$I_{bc} = -i_{ab}I_b + i_{ca}I_c \quad (152) \quad Y_b = DY_{ab}Y_{bc} \quad (148)$$

$$I_{ca} = -i_{bc}I_c + i_{ab}I_a \quad (153) \quad Y_c = DY_{bc}Y_{ca} \quad (149)$$

$$\text{where } i_{ab} = \frac{1}{DY_{ab}} \quad (154) \quad D = \frac{1}{Y_{ab}} + \frac{1}{Y_{bc}} + \frac{1}{Y_{ca}} \quad (150)$$

$$i_{bc} = \frac{1}{DY_{bc}} \quad (155)$$

$$i_{ca} = \frac{1}{DY_{ca}} \quad (156)$$

17. Examples of Solution by Reduction

A power-distribution system network is solved by the method of reduction in Sec. 20.

The following example is also given showing the method when two sources of emf are present.

Solve for the currents in the network of Fig. 11(a) by the method of reduction for applied voltages as follows:

- Case 1. $E_a = 0 + j100$ volts
 $E_d = 50 + j0$ volts
- Case 2. $E_a = 30 + j40$ volts
 $E_d = 10 + j60$ volts

Obtain unit current division and total current division as indicated in Tables 4(a) and 5.

The method generally is to resolve the network for one applied voltage at a time, with the other one set equal to zero.

After solutions have been obtained for each applied voltage acting independently, these solutions are superposed to obtain the current flow with both applied voltages acting simultaneously.

Particular attention is directed to certain relationships. The total current input resulting from a particular applied emf is obtained by dividing it by the driving-point impedance* at that pair of terminals. Thus, when the driving-point impedances, Z_{aa} and Z_{dd} , at the impressed voltage terminals have been determined, and the unit current divisions developed, the network is solved. This is illustrated by Cases 1 and 2, which differ only in magnitude of the applied voltages. The resulting currents in these two cases are obtained from the same basic network solution.

Solution—a. Eliminate the mutual as per Eqs. (111-113) and combine impedances in series forming Z_g .

$$Z_h = j20 - j10 = j10$$

$$Z_k = j30 - j10 = j20$$

$$Z_g = j10 + j30 = j40$$

b. Let $E_d = 0$ and replace star Z_e, Z_d, Z_h by its equivalent delta from Eqs. (97-100).

$$D = \frac{1}{j20} + \frac{1}{j5} + \frac{1}{j10} = -j(0.05 + 0.20 + 0.10) = -j0.35$$

$$Z_{eh} = (-j0.35)(j20)(j10) = j70$$

$$Z_{de} = (-j0.35)(j20)(j5) = j35$$

$$Z_{dh} = (-j0.35)(j5)(j10) = j17.5$$

c. Parallel the branches Z_{de} and Z_l also, Z_{dh} and Z_k of Fig. 11(c), obtaining Fig. 11(d).

$$D = Z_l + Z_{de} = j45$$

$$i_t = \frac{Z_{de}}{D} = \frac{j35}{j45} = 0.78$$

$$i_{de} = 1 - 0.78 = 0.22 \text{ (in } Z_{de})$$

$$Z_m = 0.22 \times j35 = j7.77$$

(Parallel Z_{dh} and Z_k)

$$D = Z_k + Z_{dh} = j20 + j17.5 = j37.5$$

$$i_k = \frac{Z_{dh}}{D} = \frac{j17.5}{j37.5} = 0.468$$

$$i_{dh} = 1 - i_k = 0.532 \text{ (in } Z_{dh})$$

$$Z_n = 0.532 \times j17.5 = j9.333$$

d. $Z_m + Z_n = Z_{mn} = j17.10$

Parallel Z_{mn} with $Z_{eh} = Z_o$

$$D = Z_{mn} + Z_{eh} = j17.10 + j70 = j87.10$$

$$i_{eh} = \frac{Z_{mn}}{D} = \frac{j17.10}{j87.10} = 0.196 \text{ (through } Z_{eh})$$

$$i_{mn} = 1 - i_{eh} = 0.804 \text{ (through } Z_{mn})$$

$$Z_o = i_{mn}Z_{mn} = 0.804 \times j17.10 = j13.74$$

e. The impedance viewed from E_a terminals is:

$$Z_{aa} = Z_o + Z_g = j13.74 + j40 = j53.74$$

f. Current Division for unit current in at (a).

The symbol (i) has been used for current division factors.

Let prime symbols be used for the currents in terms of one ampere total input to the network.

*Driving-point impedance is that impedance measured looking into any pair of terminals of a passive network with all other terminals terminated in a specified manner. In this case all other terminals are short-circuited.

$$\begin{aligned}
 i_g' &= 1.0 = i_a' \\
 i_{eh}' &= i_{eh} = 0.196 \\
 i_{mn}' &= 0.804 \\
 i_k' &= i_{mn}' i_k = 0.804 \times 0.468 = 0.375 = i_o' \\
 i_{dh}' &= i_{mn}' i_{dh} = 0.804 \times 0.532 = 0.429 \\
 i_t' &= i_{mn}' i_t = 0.804 \times 0.78 = 0.625 \\
 i_{de}' &= i_{mn}' i_{de} = 0.804 \times 0.22 = 0.179 \\
 i_o' &= 0.196 + 0.179 = 0.375 \\
 i_b' &= 0.196 + 0.429 = 0.625 = i_b' \\
 i_d' &= 0.429 - 0.179 = 0.250
 \end{aligned}$$

The six currents $i_a', i_o', i_t', i_o', i_d', i_b'$ are given in Table 4(a) and constitute the current division corresponding to unit current entering the network at a . Figs. 12(a) to (c) illustrate the steps in dividing the current.

g. Transfer admittances. See Table 4(b):

$$\begin{aligned}
 Y_{aa} &= \frac{1}{Z_{aa}} = \frac{1}{j53.74} = -j0.01861 \\
 Y_{ab} &= i_b' Y_{aa} = j0.01163 \\
 Y_{ac} &= i_c' Y_{aa} = j0.00698 \\
 &\text{etc.}
 \end{aligned}$$

Note: The transfer admittance, Y_{ab} , is the current in branch (b) in the reference direction per unit voltage impressed in branch (a) in the reference direction.

TABLE 3

Viewed From	Impedance
E_a	$Z_{aa} = j53.74$
E_d	$Z_{dd} = j19.54$

TABLE 4(a)

Unit Current in at	Unit Current Division					
	a	b	c	d	e	f
a	1.0	0.625	0.375	0.250	0.375	0.625
d	0.091	0.545	-0.455	1.00	-0.455	0.545

TABLE 4(b)—TRANSFER ADMITTANCES (See note under g)

Unit Voltage at	Current Division (Amperes)					
	a	b	c	d	e	f
a	-j0.01861	-j0.01163	-j0.00698	-j0.00465	-j0.00698	-j0.01163
d	-j0.00466	-j0.02790	+j0.02328	-j0.05118	+j0.02328	-j0.02790

TABLE 5.

Case	Condition		Current Division (Amperes)					
	E_a	E_d	I_a	I_b	I_o	I_d	I_o	I_t
1	0+j100	0	1.861*	1.163	0.698	0.465	0.698	1.163
	0	50+j0	-j0.233	-j1.395	+j1.164	-j2.559*	+j1.164	-j1.395
	0+j100	50+j0	1.861-j0.233	1.163-j1.395	0.698+j1.164	0.465-j2.559	0.698+j1.164	1.163-j1.395
2	30+j40	0	0.746-j0.559*	0.466-j0.349	0.280-j0.210	0.186-j0.139	0.280-j0.210	0.466-j0.349
	0	10+j60	0.280-j0.047	1.674-j0.279	-1.397+j0.233	3.071-j0.512*	-1.397+j0.233	1.674-j0.279
	30+j40	10+j60	1.026-j0.605	2.140-j0.628	-1.117+j0.023	3.257-j0.651	-1.117+j0.023	2.140-j0.628

*Total current for which the distribution is shown in that horizontal line.

In a similar manner, for voltage applied at (d), the driving-point impedance Z_{dd} and the current division and transfer admittances can be obtained. These are given in Tables 3 and 4. It is essential that the same reference directions be maintained for all current divisions, in order that the solutions for applied voltages at different terminals can be superposed.

The current divisions of Table 5 for the conditions indicated in the second and third columns are obtained directly from the basic network solution Tables 3 and 4. For example with $E_a = 0 + j100$,

$$I_a = \frac{E_a}{Z_{aa}} = \frac{0 + j100}{j53.74} = 1.861$$

$$\text{(or } I_a = E_a Y_{aa} = -j0.01861(j100) = 1.861)$$

Multiplying by the unit current division corresponding to current in at a , the currents I_a to I_t , for 1.861 amperes in at a , are determined.

This method is particularly advantageous when many different combinations of applied voltages are to be applied to the same network. It is also convenient to obtain the transfer admittances, as shown in Table 4(b). These are the currents in the various branches corresponding to unit voltages applied at the respective driving points. It is necessary only to multiply by any actual single applied voltage to obtain the corresponding current division. There is a check here, for the reciprocal theorem states that the current at (d) for unit voltage applied at (a) must be the same as the current at (a) for unit voltage applied at (d).

18. Solution by Thevenin's Theorem

*Thevenin's Theorem*² is useful in analyzing a network or part of a network when its reactions at a particular pair of terminals are of prime importance. Through its use, a complicated network consisting of several emfs and impedances can be replaced by a simple series circuit of one emf and one impedance supplying the pair of terminals of interest. The theorem can be stated as follows:

With respect to any single external circuit connected to any

given pair of terminals of a network, the network can be replaced by a single branch having an impedance, Z , equal to the impedance measured at these terminals looking into the network (when all the network emfs are made zero) and containing a single emf, E_o , equal to the open-circuit voltage of the network across the given pair of terminals.

The term emf as used here has a broader meaning than electromotive force. It is any voltage in the network that remains constant while the impedance connected to the output terminals is varied. Thus, the voltage of a battery of negligible internal impedance is an emf, while the voltage drop in an impedance is not, unless the current is held constant. (See later paragraph). A generator having regulation is segregated into an emf and an internal impedance, back of which the voltage is constant for the particular problem and hence can be treated as an emf.

The General Case is illustrated by Fig. 26. The emfs, E_1 , E_2 , and E_3 can be of any single frequency. If more than one frequency is present, the emfs of each frequency must be treated separately, as the equivalent circuit will not usually be the same for different frequencies. The impedances may be composed of resistances, inductances and capacitances, but must be linear within the accuracy necessary for the problem at hand. A linear impedance is one that satisfies Ohm's Law, $E=IZ$, Z being a constant.

With these considerations as a basis, Thevenin's Theorem states that the circuit of Fig. 26(d) is equivalent to

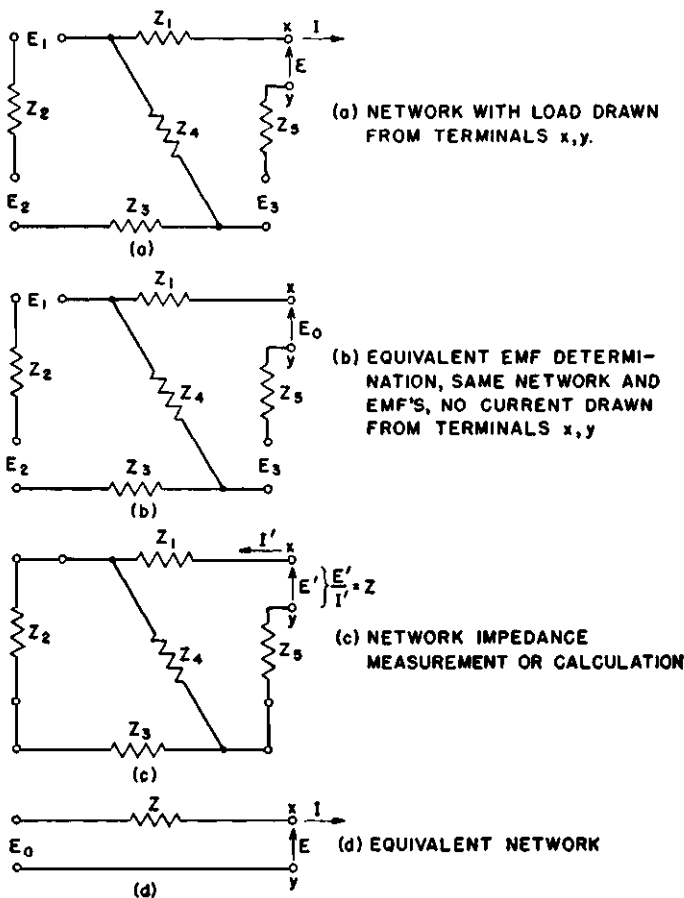

Fig. 26—Determination of equivalent network by means of Thevenin's Theorem.

the circuit of Fig. 26(a), so far as the terminals x, y are concerned. E_o is as measured with the terminals x, y open circuited in Fig. 26(b). Z is as measured in Fig. 26(c) by applying any voltage E' of the frequency under consideration to x, y and measuring the corresponding vector current I' with the emfs E_1, E_2 and E_3 short circuited. Z is the vector quotient E'/I' .

An Example of the use of this theorem is found in the calculation of short-circuit current on a loaded system. The equivalent circuit of the system, up to the point of fault, consists of an emf, E_o , and an impedance, Z . E_o is the voltage at the point of fault before the fault and is usually a known system operating voltage. Z is the impedance looking into the system at the point of fault with all emfs set equal to zero. The short-circuit current is then:

$$I = \frac{E_o}{Z}$$

Thus, it is unnecessary to determine the generator internal voltages. At a given operating voltage E_o , and fixed generating capacity, increased load tends to increase short-circuit current by lowering Z , the driving-point impedance at the fault with all system emfs set equal to zero.

The method applies equally well to a network in which certain fixed currents are forced to flow, as by current transformers. Examination of the equations of a network having fixed current input reveals its identity with a network of fixed emfs. For example, consider the circuit of

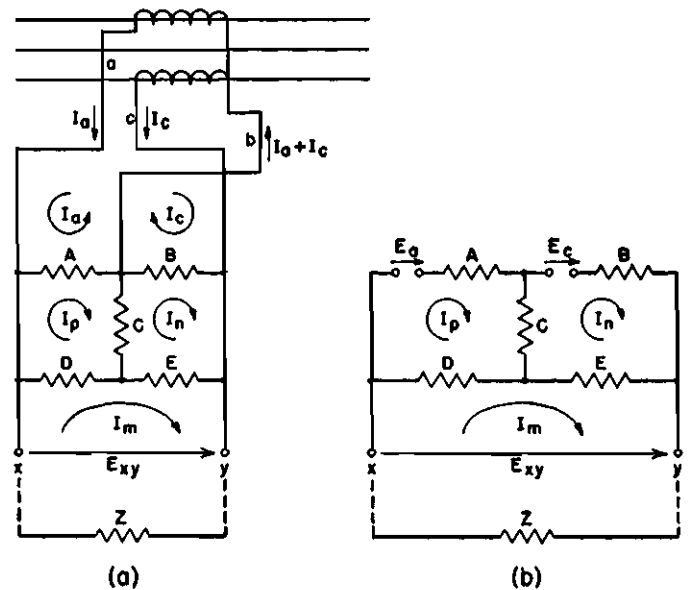

Fig. 27—Application of Thevenin's Theorem in a network of fixed input currents.

Fig. 27(a). The equations that involve the known input currents are:

$$-I_a A - I_p(A + C + D) + I_n C + I_m D = 0 \quad (157)$$

$$+ I_c B - I_n(B + E + C) + I_p C + I_m E = 0 \quad (158)$$

The equations involving E_a and E_o in Fig. 27(b) are:

$$E_a - I_p(A + C + D) + I_n C + I_m D = 0 \quad (159)$$

$$+ E_c - I_n(B + E + C) + I_p C + I_m E = 0 \quad (160)$$

Equations for the remainder of the network are the same

for Fig. 27(a) or (b). It is apparent that (157) and (158) are identical with (159) and (160) respectively, if:

$$E_a = -I_a A \tag{161}$$

$$E_c = -I_c B \tag{162}$$

In other words, the terms $-I_a A$ and $-I_c B$ can be treated as emfs in applying Thevenin's Theorem, and the performance at terminals x, y treated through the use of open-circuit voltage and driving-point impedance. The latter is obtained with the input-current terminals, that is, the $a, b,$ and c leads from the current transformers, open circuited in Fig. 27(a), or the equivalent emfs, E_a and E_b , of Fig. 27(b) set equal to zero.

A more complete discussion is given in Reference Number 2.

19. Solution by Circulating Currents

A ladder-type network common where transmission and distribution circuits parallel each other as in a-c railway electrification³ is represented in Fig. 28. The example is,

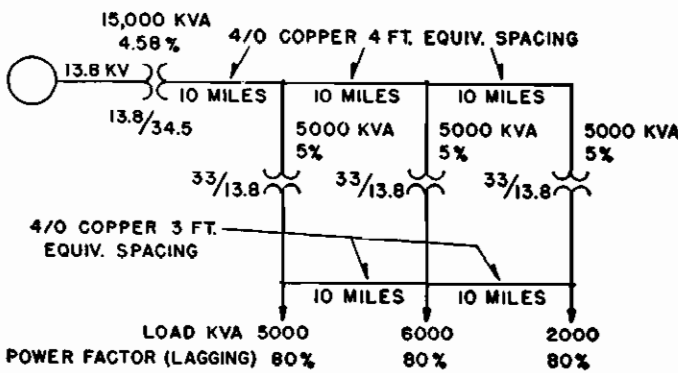

Fig. 28—A general ladder-type network.

however, for a three-phase system. Suppose it is desired to determine the current division and regulation for the particular loading condition shown, without making a general solution of the network. This problem lends itself to the method of circulating currents.

The voltages at the load buses must first be assumed and the kva loads converted to currents. The sum of the three load currents flow in the generator and constitute the current I_a in Fig. 29. These load currents and the generator current are assumed to be fixed for the balance of the problem.

The division of I_a between I_o and I_c is next assumed. Now the voltage drops from 1 to 2, 2 to 5 and 2 to 3 can

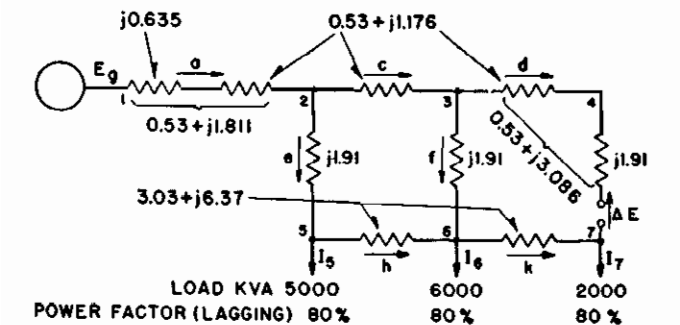

Fig. 29—Impedance diagram for the system of Fig. 28. Showing the method of circulating currents.

be calculated. The current I_b is obtained by subtracting the load at 5 from I_e , and then the drop from 5 to 6 can be computed. Knowing the drops from 2 to 3 and 2 to 6, for the assumed current division, the drop from 3 to 6 is obtained by subtraction. This drop divided by the impedance f gives the current I_f . Now the balance of the currents can be obtained, that is, I_d and I_k . However unless a perfect guess has been made, the drop 3-4-7 will differ from the drop 3-6-7, and an arbitrary voltage, ΔE , must be included to make the voltages around the loop add to Zero.

So far an exact solution has been obtained for the case of certain load currents, a particular generator voltage and a voltage ΔE . However, the solution is desired without ΔE . To obtain it a solution is next obtained for $-\Delta E$ acting alone. According to the conditions of the problem the load and generator currents are fixed so that these branches are considered open circuited when computing the currents caused by $-\Delta E$ alone. This solution is therefore quite simple and gives rise to a set of currents $I'_c, I'_d, \dots I'_k$, which are the "circulating currents" for which the method is named.

Now let these two solutions be superposed; that is:

$$I_c'' = I_c + I'_c$$

$$I_d'' = I_d + I'_d \text{ etc.}$$

The resulting solution does not involve ΔE since the ΔE of the first solution is canceled by the $-\Delta E$ of the second solution. It is therefore an exact solution for the load currents assumed. The voltage drops from the generator to the several load points can now be computed, since the currents are known. Also, from the new load voltages, and from the load currents that have been held fixed throughout the solution, new load kvas and power factors can be computed.

The net result is an exact solution for a set of conditions that differs more or less from those originally assumed. While this can be used as a basis for a second approximation it is more generally considered the engineering answer. The loads are usually not known exactly; the solution obtained provides an exact reference point in the region of the loads assumed, and thereby provides a tangible basis for engineering judgment.

There is much to be said for this type of solution as a system design tool, since it capitalizes experience and foreknowledge of the order of magnitude of the answer. As an example the network of Fig. 28 has been solved for the loads indicated thereon.

Example of Method of Circulating Current—The network diagram, Fig. 29, is obtained from the single-line diagram as outlined in Secs. 2 and 3. The 15 000-kva transformer impedance should be converted to ohms on a 34.5-kv base and then multiplied by $(13.8/33)^2$ to convert to the 13.8-kv base at the load. The resulting diagram is on the load-voltage base, a conversion being necessary to change to or from the generator-voltage base, which is also nominally 13.8 kv. Thus with the generator at 13.8 kv, the corresponding voltage to be applied in Fig. 29 is $13.8(34.5/13.8) (13.8/33) = 14.42$ kv or 4.5 percent above normal. In an actual case transformer resistances should be included as these are significant in regulation and loss calculations.

As a first approximation, assume the regulation in step-up and step-down transformers to total 10 percent with an additional 10 percent in lines. Allowing for a 4.5 percent above normal voltage at the generator, the loads should be converted to currents based on approximately 85 percent voltage or 11 700 volts. The load currents are given in the following tabulation.

Location.....	5	6	7	Total
Load kva.....	5000	6000	2000	
Load Current Amps.....	245	295	98	638

In the current distribution calculation which follows, the current I_o must be guessed, or taken arbitrarily. Later a circulating current is determined, which, added to the arbitrarily assumed value, gives the correct current. It is advantageous to guess as close as possible so that the correcting circulating current is small. In fact if the guess is sufficiently close, the labor of calculating the distribution of circulating current can be saved.

I_a	=	638
I_o	=	300
$I_o = I_a - I_o$	=	338
I_b	=	245
$I_b = I_o - I_b$	=	55
I_c	=	338
Z_o	=	0.53 + j1.176
$I_o Z_o$	=	179 + j397
I_o	=	300
Z_o	=	+j1.91
$I_o Z_o$	=	+j573
I_h	=	55
Z_h	=	3.03 + j6.37
$I_h Z_h$	=	166.5 + j350
$I_o Z_o$	=	+j573
D_{256}	=	166.5 + j923
$I_o Z_o$	=	179 + j397
$I_t Z_t$	= -	13.5 + j526
Z_t	=	+j1.91
I_t	=	275 + j7.1
I_o	=	338
$I_d = I_o - I_t$	=	63 - j7.1
I_h	=	55
I_t	=	275 + j7.1
$I_h + I_t$	=	330 + j7.1
I_b	=	295
I_k	=	35 + j7.1
Z_d	=	0.53 + j3.086
I_d	=	63 - j7.1
$I_d Z_d$	=	55.3 + j190.7
Z_k	=	3.03 + j6.37
I_k	=	35 + j7.1
$I_k Z_k$	=	60.8 + j244.5
$I_t Z_t$	= -	13.5 + j526
D_{367}	=	47.3 + j770.5
$D_{347} = I_d Z_d$	=	55.3 + j190.7
ΔE	= -	8.0 + j579.8

Solution for Circulating Current.

Find the impedance as viewed from ΔE with load and generator branches taken as constant current branches, i.e., open circuited for this calculation. Apply a voltage $\Delta E' =$ negative of the ΔE required to close the mesh in the above calculation.

Z_o	=	0.53 + j 1.176
Z_o	=	+j 1.91
Z_h	=	3.03 + j 6.37
Z_{256}	=	3.56 + j 9.456
Z_t	=	+j 1.91
D	=	3.56 + j11.366
$1/D$	=	0.0251 - j 0.0801
Z_t	=	+j 1.91
$Z_t/D = i_{256}$	=	0.1530 + j 0.0479
$i_t = 1 - i_{256}$	=	0.8470 - j 0.0479
Z_t	=	+j 1.91
Z_{par}	=	0.0915 + j 1.618
Z_d	=	0.53 + j 3.086
Z_k	=	3.03 + j 6.37
Z	=	3.6515 + j11.074
$1/Z$	=	0.0269 - j 0.0814
$-\Delta E = \Delta E'$	=	8.0 - j579.8
$I_k' = \Delta E'/Z$	=	-46.98 - j16.25
$I_d' = -I_k'$	=	46.98 + j16.25
i_{256}	=	0.1530 + j 0.0479
I_o'	=	6.41 + j 4.74
$I_t' = I_o' - I_d'$	=	-40.57 - j11.51
$I_o'' = -I_o'$	=	- 6.41 - j 4.74
$I_h' = -I_o'$	=	- 6.41 - j 4.74

The currents from the arbitrary distribution (requiring ΔE to close) and the circulating currents contributed by $\Delta E' = -\Delta E$, are now combined to get the actual current division for the load currents assumed. The circulating currents are distinguished by prime symbols, the total division by double-primes. Fig. 30 illustrates this superposition.

$I_a'' = I_a$	=	638 + j0
I_o	=	300 + j0
I_o'	= -	6.4 - j4.7
I_o''	=	293.6 - j4.7
I_o	=	338 + j0
I_o'	=	6.4 + j4.7
I_o''	=	344.4 + j4.7
I_h	=	55 + j0
I_h'	= -	6.4 - j4.7
I_h''	=	48.6 - j4.7
I_t	=	275 + j 7.1
I_t'	= -	40.6 - j11.5
I_t''	=	234.4 - j 4.4
I_d	=	63 - j 7.1
I_d'	=	47.0 + j16.3
I_d''	=	110.0 + j 9.2
I_k	=	35 + j 7.1
I_k'	= -	47.0 - j16.3
I_k''	= -	12 - j 9.2

Check of Drops Around Loops. This solution can be checked by checking voltage drops around each loop.

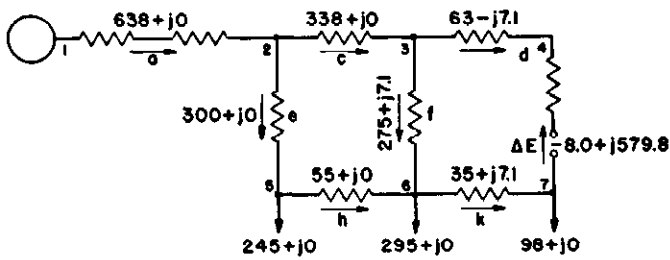

(a) ARBITRARY DIVISION AND VOLTAGE ΔE REQUIRED TO CLOSE

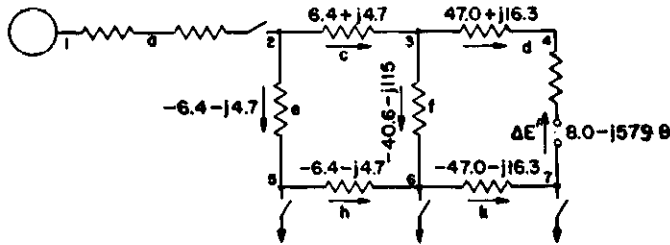

(b) CURRENTS DUE TO $\Delta E' = -\Delta E$

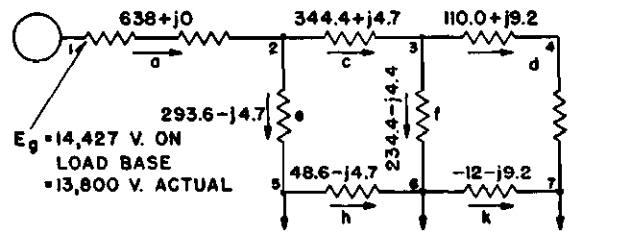

LOAD CURRENT	245+j0	295+j0	98+j0
LOAD VOLTAGE	12,022	11,473	11,547
REG. BELOW 13,800 V.	12.82%	16.86%	16.32%
KW + j REACTIVE KVA	4081-j3061	4757-j3424	1574-j1168
LOAD KVA	5101	5861	1960
POWER FACTOR (LAG.)	80.0%	81.2%	80.3%

(c) SUPERPOSITION OF (a) AND (b)

Fig. 30—Solution of the network of Fig. 28 by the method of circulating currents.

Calculate the drop from generator bus to load point 5.

$$\begin{aligned} I_a &= 638.0 + j0 \\ Z_a &= 0.53 + j1.811 \\ I_a Z_a &= 338.1 + j1155.4 \\ I_a'' Z_a &= 9.0 + j560.8 \\ D_{125} &= 347.1 + j1716.2 \end{aligned}$$

Regulation—Determination of Load Voltages. The magnitude of the generator voltage is known, but not its phase position. The phase position of the load voltage E_s is known but not its magnitude. It is at an 80-percent power factor position with respect to I_s . The drop from generator to load point 5, D_{125} , is known vectorially with I_s as reference. Thus the magnitude, \bar{E}_s , can be determined by the solution of a quadratic equation as shown below, or graphically as indicated in Fig. 31.

$$\begin{aligned} E_s &= \bar{E}_s(0.8 + j0.6) \\ E_s + D_{125} &= E_g \\ E_g &= 0.8\bar{E}_s + 347.1 + j(0.6\bar{E}_s + j1716.2) \\ E_g^2 &= \frac{(14427)^2}{3} = (0.8\bar{E}_s + 347.1)^2 + (0.6\bar{E}_s + 1716.2)^2 \\ \bar{E}_s^2 + 2(1307.4)\bar{E}_s - 66.313 \times 10^6 &= 0 \\ \bar{E}_s &= -1307.4 \pm \sqrt{(1307.4)^2 + 66.313 \times 10^6} \end{aligned}$$

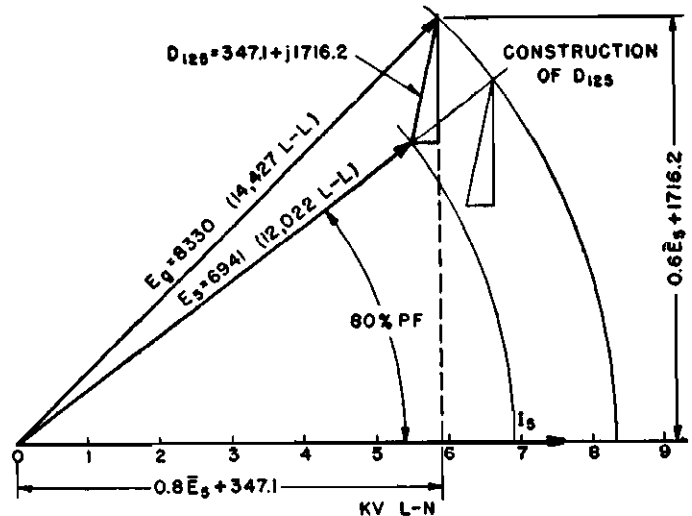

Fig. 31—Graphical determination of the load voltage \bar{E}_s in Fig. 28.

1. The load current I_s is along the reference line.
2. Draw circle of radius 8330 volts on which E_g must terminate.
3. Draw construction line at the load power factor (80 percent) along which E_s must lie.
4. Construct the voltage drop vector, D_{125} , and move it parallel to itself, with one end following the generator voltage circle, until the other end falls on the load voltage construction line.
5. E_g and E_s can then be drawn in and their vector values scaled off.

$$\begin{aligned} \bar{E}_s &= -1307.4 \pm 8248 \\ &= 6941 \text{ volts L-N} \\ &= 12,022 \text{ volts L-L} \\ &= 87.12 \text{ percent of } 13,800 \\ &= 83.33 \text{ percent of } 14,427 \\ E_s &= 6941 \times (0.8 + j0.6) \\ E_s &= 5553 + j4165 \end{aligned}$$

Check of Voltage Drop from 1 to 5.

$$\begin{aligned} E_s &= 5553 + j4165 \\ D_{125} &= 347 + j1716 \\ E_g &= 5900 + j5881 \\ &= 8330.4 \text{ L-N} \\ &= 14428 \text{ L-L} \end{aligned}$$

The remaining load voltages are readily determined as follows:

$$\begin{aligned} E_6 &= 5553 + j4165 \\ I_k'' Z_k &= 177.2 + j295.3 \\ E_6 &= 5375.8 + j3869.7 \\ &= 6624 \text{ L-N} \\ &= 11,473 \text{ L-L} \\ &= 83.14\% \text{ of } 13,800 \\ &= 79.52\% \text{ of } 14,427 \\ E_7 &= 5375.8 + j3869.7 \\ I_k'' Z_k &= 22.2 - j104.3 \\ E_7 &= 5353.6 + j3974.0 \\ &= 6667 \text{ L-N} \\ &= 11,547 \text{ L-L} \\ &= 83.68\% \text{ of } 13,800 \\ &= 80.04\% \text{ of } 14,427 \end{aligned}$$

Load Power Calculations.

$$\begin{aligned} E_5 &= (5.553 + j4.165) \text{ kv} \\ 3I_5 &= \frac{735}{-j0} \\ P_5 + jQ_5 &= \frac{(4081 + j3061) \text{ kva}}{5101 \text{ kva}} \\ &\text{at 80.00 percent power factor lagging.} \end{aligned}$$

$$\begin{aligned} E_6 &= (5.375 + j3.869) \text{ kv} \\ 3I_6 &= \frac{885}{-j0} \\ P_6 + jQ_6 &= \frac{(4757 + j3424) \text{ kva}}{5861 \text{ kva}} \\ &\text{at 81.16 percent power factor lagging.} \end{aligned}$$

$$\begin{aligned} E_7 &= (5.354 + j3.974) \text{ kv} \\ 3I_7 &= \frac{294}{-j0} \\ P_7 + jQ_7 &= \frac{(1574 + j1168) \text{ kva}}{1960 \text{ kva}} \\ &\text{at 80.31 percent power factor lagging.} \end{aligned}$$

Generator Output Power.

$$\begin{aligned} E_g &= (5.900 + j5.881) \text{ kv} \\ 3I_g &= \frac{1914}{-j0} \\ P_g + jQ_g &= \frac{(11293 + j11256) \text{ kva}}{15945 \text{ kva}} \\ &\text{at 70.82 percent power factor lagging.} \end{aligned}$$

Loss Calculation.

$$\begin{aligned} P_5 + jQ_5 &= 4081 + j3061 \\ P_6 + jQ_6 &= 4757 + j3424 \\ P_7 + jQ_7 &= 1574 + j1168 \\ \text{Total of Loads} &= \frac{10412 + j7653}{11293 + j11256} \\ P_g + jQ_g &= 11293 + j11256 \\ \text{Losses} &= \frac{881 + j3603}{881/11293} \\ \text{Kw Line Loss} &= 7.80 \text{ percent of generator output.} \end{aligned}$$

In an actual case transformer resistances must be included in the diagram as these are significant in regulation and loss calculations. Transformer iron losses must be added to the copper losses thus determined to obtain the total loss.

The solution given in Fig. 30 is exact for the conditions shown on the figure, which differ slightly from the original assumptions of Fig. 28. However, the total load is off only 1.3 percent and the regulation values therefore apply closely for the original conditions. In a practical problem it is not significant that the answer does not apply exactly to the original load assumptions. If the work is done with a calculating machine so that several significant figures can be carried, losses can be computed as the difference between input and output power, as shown.

III. REPRESENTATION OF NETWORK SOLUTIONS AND THEIR USE IN SYSTEM PROBLEMS

Network solutions can be represented in a variety of ways. For example a diagram can be labeled with all pertinent information obtained in the solution as in Fig.

30. This scheme is used most commonly in expressing current distributions. The solution can also be expressed as a tabulation of self and mutual drops and current division, or in the form of driving point and transfer impedances or admittances. General circuit constants such as the ABCD constants or P_i and T equivalents can also be used to express the solution of certain types of networks. The following paragraphs describe these several methods of representing solutions and their uses.

20. Method of Self and Mutual Drops

The method of self and mutual drops constitutes one of the most useful means for fully describing the action of a complicated network in the form of a table of system constants. It is applicable principally to single-source systems or to systems in which all of the generator voltages can be taken equal and in phase. However, its use can be extended to multiple-source systems provided that either:

- All sources but one are treated as negative loads,
- The emfs of the several sources are fixed in magnitude and phase position with respect to each other.

The method will be described with respect to the single-source system, and the multiple-source system treated as an extension.

A Single-Source System Without Shunt Branches

other than the loads, is shown in Fig. 32(a). Each of the loads draws current through the network causing voltage drop from the generator bus g to the bus on which it is connected. Each load likewise causes voltage drops to the other loads, known as mutual drops. As these drops are proportional to the load current, they can be determined by finding first the drop resulting from unit load and multiplying by the value of load. Accordingly, the following definitions will be found of use.

Z_{aa} is the voltage drop from g to a caused by unit load current drawn from the network at a . It is called the self drop constant.

Z_{ab} is the voltage drop from g to b caused by unit load current drawn from the network at a . It is called the mutual drop constant.

NOTE that the self and mutual drop constants Z_{aa} and Z_{ab} as defined and used here in Sect. 20, differ from the self and mutual impedances defined and used in Sections 13 and 21. The Z with double subscript is used in each case to conform with accepted terminology.

In both cases current is admitted at g and the unit load referred to is the only load. Obviously, the self and mutual drops have the dimensions of impedance but the term drop will be retained to distinguish from the terms self and mutual impedance that are used otherwise. For unit loads at other points the self and mutual drops are similarly defined. Thus associated with the network of Fig. 32(a) are the nine drops:

$$\begin{array}{ccc} Z_{aa} & Z_{ab} & Z_{ac} \\ Z_{ba} & Z_{bb} & Z_{bc} \\ Z_{ca} & Z_{cb} & Z_{cc} \end{array}$$

The first subscript denotes the point at which unit current is drawn; the second denotes the point to which the drop is measured. However, in all cases mutual drops between the same two points are equal. That is:

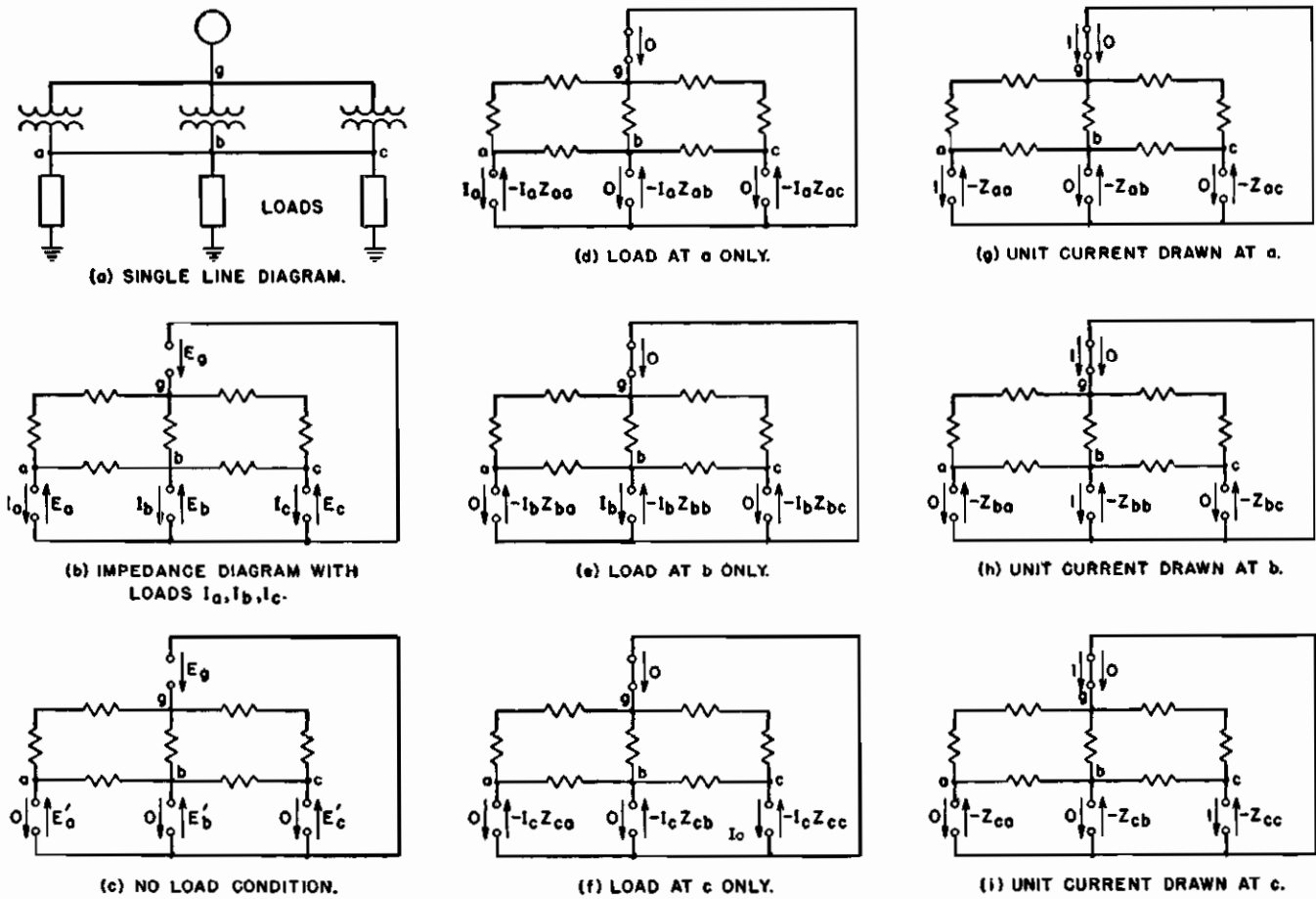

Fig. 32—A single-source system without shunt branches. Illustrating the method of self and mutual drops.

TABLE 6—CURRENT DIVISION

Unit Load at	Current						
	I_{GA}	I_{GD}	I_{GC}	I_{DC}	I_{CA}	I_{CB}	I_{AB}
A	0.667 - j0.013	0.197 - j0.003	0.136 + j0.016	0.197 - j0.003	0.243 - j0.003	0.090 + j0.016	-0.090 - j0.016
B	0.556 - j0.021	0.264 - j0.002	0.181 + j0.023	0.264 - j0.002	-0.040 + j0.017	0.484 + j0.004	0.516 - j0.004
C	0.445 - j0.029	0.329 - j0.000	0.226 + j0.029	0.329 - j0.000	-0.323 + j0.037	-0.122 - j0.008	0.122 + j0.008
D	0.060 + j0.005	0.911 - j0.013	0.029 + j0.008	-0.089 - j0.013	-0.044 - j0.001	-0.016 - j0.004	0.016 + j0.004

$$Z_{ab} = Z_{ba} \quad (163)$$

$$Z_{ac} = Z_{ca} \quad (164)$$

$$Z_{bc} = Z_{cb} \quad (165)$$

The resulting tabulations of current division and self and mutual drops, as illustrated in Tables 6 and 7 for the network of Fig. 33, are the basic network solution. They

The drops can be calculated or measured on a network calculator. Unit current is drawn from one of the points of interest, for example load point *a* of Fig. 32(a), and the voltage drops from the reference bus, *g*, to each of the load points *a*, *b*, and *c* measured or calculated. These are the self and mutual drops Z_{aa} , Z_{ab} , and Z_{ac} , respectively. The current division for this condition should likewise be recorded.

This process is repeated in turn for the other cardinal load points *b* and *c*. Mutual drops must check according to Eqs. (163–165). If the solution is to be used for a study of short circuits and relaying, it is generally necessary to include many cardinal points that are not strictly load points, but are line junctions, etc.

TABLE 7
Self and Mutual Drops

Unit Load At	Voltage Drop to			
	A	B	C	D
A	Z_{AA} 1.28 + j2.08	Z_{AB} 1.10 + j1.71	Z_{AC} 0.916 + j1.345	Z_{AD} 0.10 + j0.19
B	Z_{BA} 1.092 + j1.712	Z_{BB} 2.447 + j3.554	Z_{BC} 1.200 + j1.808	Z_{BD} 0.126 + j0.263
C	Z_{CA} 0.91 + j1.36	Z_{CB} 1.203 + j1.82	Z_{CC} 1.49 + j2.28	Z_{CD} 0.154 + j0.328
D	Z_{DA} 0.096 + j0.196	Z_{DB} 0.125 + j0.261	Z_{DC} 0.154 + j0.326	Z_{DD} 0.440 + j0.897

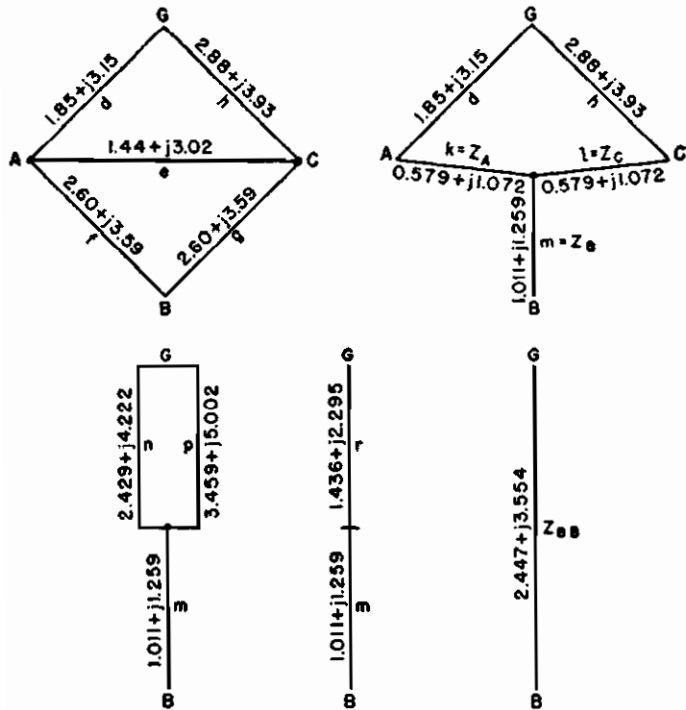

Fig. 34—Reduction of the system of Fig. 33 with respect to terminals G and B.

a delta-to-star conversion. Current distribution factors, symbol i , obtained in the course of this reduction are used later in the current distribution calculation. The steps of reduction are illustrated in Fig. 34. The steps in the subsequent current distribution calculation are illustrated in Fig. 35, the network being expanded in reverse order, to its original form. Fig. 35(c) shows the current distribution for a one ampere load at B. The mutual drops are then obtained by calculating the voltage drop from generator to each load point, using the impedance diagram Fig. 33 and current diagram Fig. 35(c).

This procedure is repeated in turn for unit current at each of the load points, and the results tabulated as in Tables 6 and 7. The symbols Z_{AA} , Z_{AB} have been included in Table 7 to identify the drops, but this in general is not necessary.

Typical Calculation of Self and Mutual Drops and Current Division. Unit Load at B

Combine a and c in Series.

$$\begin{aligned} a &= 0.47 + j 1.00 \\ c &= 4.05 + j 5.90 \\ a+c &= 4.52 + j 6.90 \end{aligned}$$

Parallel b with $a+c$.

$$\begin{aligned} a+c &= 4.52 + j 6.90 \\ b &= 7.78 + j 9.04 \\ D = \text{sum} &= 12.30 + j 15.94 \\ 1/D &= 0.03034 - j 0.03932 \\ a+c &= 4.52 + j 6.90 \\ i_b = (a+c)/D &= 0.4075 + j 0.0321 \\ b &= 7.78 + j 9.04 \end{aligned}$$

$$h = \text{parallel } b \text{ with } (a+c) = 2.8802 + j 3.9335$$

Convert Delta ABC to Star*

$$\begin{aligned} Z_{A-B}^{**} &= 2.60 + j 3.59 \\ Z_{B-C} &= 2.60 + j 3.59 \\ Z_{C-A} &= 1.44 + j 3.02 \\ D = \text{sum} &= 6.64 + j 10.20 \\ 1/D &= 0.04483 - j 0.06886 \\ Z_{A-B} &= 2.60 + j 3.59 \\ i_{AB} = Z_{A-B}/D &= 0.3638 - j 0.0181 \\ Z_{C-A} &= 1.44 + j 3.02 \\ Z_A = Z_{C-A}i_{AB} &= 0.5785 + j 1.0724 \\ 1/D &= 0.04483 - j 0.06886 \\ Z_{B-C} &= 2.60 + j 3.59 \\ i_{BC} = Z_{B-C}/D &= 0.3638 - j 0.0181 \\ Z_{A-B} &= 2.60 + j 3.59 \\ Z_B = Z_{A-B}i_{BC} &= 1.0109 + j 1.2590 \\ 1/D &= 0.04483 - j 0.06886 \\ Z_{C-A} &= 1.44 + j 3.02 \\ i_{CA} = Z_{C-A}/D &= 0.2725 + j 0.0362 \\ Z_{B-C} &= 2.60 + j 3.59 \\ Z_C = Z_{B-C}i_{CA} &= 0.5785 + j 1.0724 \end{aligned}$$

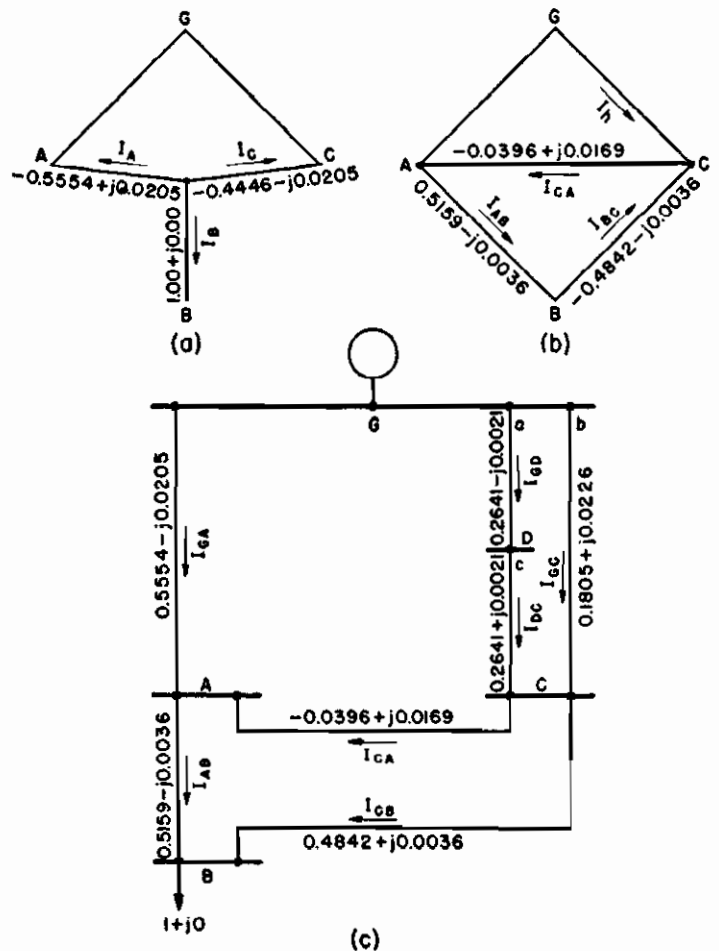

Fig. 35—Current distribution in the network of Fig. 33 for unit load at B.

*See equations (87)—(96).

** Z_{A-B} is used here for impedance of branch from A to B to distinguish it from Z_{AB} , the drop to B for unit load at A.

Refer to Fig. 34 and Combine d and k in Series.

$$\begin{aligned} d &= 1.85 + j3.15 \\ k &= 0.579 + j1.072 \\ n = d + k &= 2.429 + j4.222 \end{aligned}$$

Series h and l .

$$\begin{aligned} h &= 2.88 + j3.93 \\ l &= 0.579 + j1.072 \\ p = h + l &= 3.459 + j5.002 \end{aligned}$$

Parallel n and p .

$$\begin{aligned} n &= 2.429 + j4.222 \\ p &= 3.459 + j5.002 \\ D = \text{sum} &= 5.888 + j9.224 \\ 1/D &= 0.04917 - j0.07703 \\ p &= 3.459 + j5.002 \\ i_n = p/D &= 0.5554 - j0.0205 \\ n &= 2.429 + j4.222 \\ r = pn/D &= 1.4356 + j2.2951 \\ i_p = 1 - i_n &= 0.4446 + j0.0205 \end{aligned}$$

Series r and m .

$$\begin{aligned} r &= 1.4356 + j2.2951 \\ m &= 1.011 + j1.259 \\ Z_{BB} &= 2.4466 + j3.5541 \end{aligned}$$

Current Division*. Refer to Figs. 35 and 34.

$$\begin{aligned} I_A = -i_n &= -0.5554 + j0.0205 \\ I_B &= 1.0000 + j0.0000 \\ I_C = -i_p &= -0.4446 - j0.0205 \\ -i_{CA} &= -0.2725 - j0.0362 \\ I_A &= -0.5554 + j0.0205 \\ -i_{CA}I_A &= 0.1521 + j0.0145 \\ i_{BC} &= 0.3638 - j0.0181 \\ I_B &= 1.0000 + j0.0000 \\ i_{BC}I_B &= 0.3638 - j0.0181 \\ I_{AB} &= 0.5159 - j0.0036 \\ &= -i_{CA}I_A + i_{BC}I_B \\ -i_{AB} &= -0.3638 + j0.0181 \\ I_B &= 1.0000 + j0.0000 \\ -i_{AB}I_B &= -0.3638 + j0.0181 \\ i_{CA} &= 0.2725 + j0.0362 \\ I_C &= -0.4446 - j0.0205 \\ i_{CA}I_C &= -0.1204 - j0.0217 \\ I_{BC} &= -0.4842 - j0.0036 \\ &= -i_{AB}I_B + i_{CA}I_C \\ -i_{BC} &= -0.3638 + j0.0181 \\ I_C &= -0.4446 - j0.0205 \\ -i_{BC}I_C &= 0.1621 - j0.0006 \\ i_{AB} &= 0.3638 - j0.0181 \\ I_A &= -0.5554 + j0.0205 \\ i_{AB}I_A &= -0.2017 + j0.0175 \\ I_{CA} &= -0.0396 + j0.0169 \\ &= -i_{BC}I_C + i_{AB}I_A \end{aligned}$$

*See equations (88b), (89b), (90b).

$$\begin{aligned} I_b = -I_C &= 0.4446 + j0.0205 \\ i_b &= 0.4075 + j0.0321 \\ I_{GC} = i_b I_b &= 0.1805 + j0.0226 \\ I_{GD} = I_b - I_{GC} &= 0.2641 - j0.0021 \end{aligned}$$

Mutual Drops.

$$\begin{aligned} I_{GA} &= 0.5554 - j0.0205 \\ d &= 1.85 + j3.15 \\ Z_{BA} &= 1.0921 + j1.7116 \\ I_{GC} &= 0.1805 + j0.0226 \\ b &= 7.78 + j9.04 \\ Z_{BC} &= 1.2000 + j1.8075 \\ I_{GD} &= 0.2641 - j0.0021 \\ a &= 0.47 + j1.00 \\ Z_{BD} &= 0.1262 + j0.2631 \end{aligned}$$

The current division and self- and mutual-drop factors from these calculations are tabulated in Tables 6 and 7, together with similar factors for unit loads at A , C , and D .

Regulation—Tables 6 and 7 are considered to be the basic network solution. Their use in the regulation problem will now be outlined.

The chief problem is to express the several load currents in proper phase relationship to a single reference voltage, either the voltage at one of the most important load points or the generator-bus voltage.

If they are expressed with respect to the generator-bus voltage, a simple deduction of vector drops from this voltage gives the load point voltages so that the load power factors and kva can be checked and a correction made if necessary.

If there is considerable drop in the system but the important load voltages are nearly alike, it is preferable to use one of these load voltages as reference. The generator-voltage phase position can then be determined graphically or by the solution of a quadratic equation as outlined in the example of the circulating current method Sec. 19. A simplified modification of this method is given below. In either method the proof of the assumptions lies in the check of load kva and power factor and corrections can be applied if the assumed values prove to be far enough off to affect materially the regulation values and currents of interest.

The present problem is to calculate the regulation for the system of Fig. 33 under normal heavy load conditions, Case 1, Table 8, and also with several capacitor banks added as indicated in Case 2, Table 8.

A practical problem now arises that is not immediately evident from Eq. 168. The load power factors given fix the positions of the currents with respect to the final load voltages, (E_p in this equation) not with respect to the generator or "no load" voltage E'_p . Thus the phase relations between the generator voltage and the drops cannot be determined directly. A further difficulty exists in converting the loads from kva to amperes since the load voltages are not yet known.

A straightforward method of approach would be as follows. First assume that all load voltages are equal to, and in phase with, the generator voltage. Convert load kva's to vector currents with this voltage as reference.

TABLE 8—REGULATION WITHOUT CAPACITORS (CASE 1) AND WITH CAPACITORS (CASE 2)

Case	Load		Assumed Regulation	Amperes *	Resulting Drops to					
	At	kva—p.f.			B		C		D	
					Volts	%Reg.	Volts	%Reg.	Volts	%Reg.
1	B	2500—90% Lag	11.0%	130.1—j63.1	543.5+j309.1		271.4+j161.0		32.9+j26.2	
	C	4500—85% Lag	13.0%	226.6—j140.3	526.1+j240.7		656.3+j304.9		81.2+j52.9	
	D	11 200—85% Lag	9.0%	539.3—j333.7	154.9+j102.6		190.9+j123.8		539.7+j341.0	
	All	Total voltage drop Calculated load			1224.5+j652.4 2265kva—90.4% Lag	19.4	1118.6+j589.7 4254kva—84.9% Lag	17.7	653.8+j420.1 11 011kva—83.4% Lag	10.5
2	B	2500—90% plus 2500—0%† =2655—84.7% Lead	5%	122.1+j76.6	26.4+j622.0		8.0+j313.3		—4.7+j41.6	
	C	4500—85% plus 2500—0%† =3827—99.9% Lead	5%	207.5+j7.0	236.7+j384.0		293.6+j481.3		29.9+j69.3	
	D	11 200—85% plus 2500—0%† =10 110=94.2% Lag	2.5%	503.4—j179.9	110.7+j109.7		137.4+j137.6		384.7+j376.3	
	All	Total voltage drop Calculated load			373.8+j1115.7 2609kva—82.8% Lead	6.7	439.0+j932.2 3715kva—99.9% Lead	7.8	409.9+j487.2 9635kva—91.6% Lag	7.1

For Case 1 use $E_g = 6438.6 + j600$; For Case 2 $E_g = 6403.6 + j900$.

†Capacitors (6466.5 volts L-N)

*Based on load voltages—all in phase—taken as reference, but below the generating bus voltage of 11.2 kv by the “assumed regulation” values.

Then calculate and deduct the drops to determine the load voltages corresponding to this first approximation of the currents. The currents used will not have quite the right phase positions or magnitudes, when associated with these load voltages, to agree with the loads and power factors specified.

However, with these load voltages a new set of load currents can be calculated, the drops recalculated and a second approximation to the load voltages determined. This process is highly convergent and the second approximation would ordinarily be sufficient. In fact by making two judicious guesses, one an estimate of regulation to each load point and the second an estimate of phase shift from generator to load, the first approximation is nearly always sufficient and but a single calculation is required. This is the procedure followed in the subsequent paragraphs.

The assumed regulation to the load points is a straightforward estimate from experience or from the quick estimating tables of Chap. 9. However, the treatment of the phase-angle estimate bears some further explanation. First the load voltages are assumed to be in phase. Making use of the regulation estimates the vector load currents can be calculated with this common load voltage phase as a reference. The vector drops can be calculated and consist of in-phase and out-of-phase drop components. The generator voltage is now selected leading the reference by the average

reactive drop to the loads. The example will make this clear. The magnitude of generator voltage is a given quantity. It is apparent that when the drops to various load points are deducted from this generator voltage, the load voltages obtained are close to the reference phase and hence the load power factors are close to those for which a solution is desired. Thus the resulting generator voltage, load currents, and drops are now sufficiently accurate to complete the regulation calculation. An exact answer is obtained for a set of loads differing slightly from those assumed. The example will make this clear.

As the loads are given in kva and power factor, it is necessary to estimate the load voltages to convert the loads to currents. The load voltages are all assumed to be in-phase, as a first approximation, and below the normal voltage of 11.2 kv by the “assumed regulation” values listed in Table 8. Load currents are calculated on this basis using load voltage as the reference axis. For example the load current at C is for Case 1:

$$I = \frac{4500(0.85 - j0.5268)}{\sqrt{3} \times 11.2 \times (1 - 0.13)} = 266.6(0.85 - j0.5268) \\ = 226.6 - j140.3 \text{ amperes.}$$

Voltage drops are computed according to Eq. (167), the component and total drops being as shown in the table.

A rough check of the drops at the critical locations, B

and C , indicates that for normal load conditions, Case 1, the approximate in-phase drops are 1224 and 1118 volts, or approximately 19.0 and 17.2 percent of normal line-to-neutral voltage. The "assumed regulations" could be corrected at this point but as this repetition would not add to the exposition, it is omitted.

Up to this point a reference axis in phase with the load voltages has been used, the load voltages being taken all in phase. This was most convenient for converting loads to currents as the power factors were known with respect to the load voltages. Now it is necessary to determine the generator voltage with respect to this reference so that the calculated drops may be deducted from it to find the actual load voltages. The phase position of the generator voltage does not need to be determined exactly. However after the load voltages are computed, the load power will be computed and the regulation will be exact for the loads thus computed rather than for the actual given loads. Such a result is usually an adequate engineering answer as the "given loads" are seldom accurately known. However it is desirable to start with a generator voltage as near as possible to that corresponding to the assumed load voltage so that the computed loads will be close to the given loads. This is accomplished as follows.

Noting that the out-of-phase drop is approximately 600 volts for B and C , the generator bus voltage is arbitrarily taken 600 volts ahead of the load voltage or reference. The drops, as deducted from this voltage, give load voltages quite closely in phase with those used and hence the load power factors are nearly correct. As the generator voltage magnitude is 6466.5 volts, line-to-neutral, the in-phase component must be $\sqrt{(6466.5)^2 - (600)^2} = 6438$. Whence the generator bus voltage is $6438 + j 600$.

The load voltages should now be calculated and the loads checked to see that they do not differ too far from the assumptions. A typical check follows, for Case 1, load at B .

$$\begin{aligned} E_g &= 6438 + j 600 \\ D_B &= 1224 + j 652 \\ E_B &= 5214 - j 52 \\ E_B &= (5.214 - j 0.052) \text{ kv} \\ 3I_B &= 390.3 + j 189.3 \\ P_B + jQ_B &= (2050 + j 970) \text{ kva} \\ &= 2265 \text{ kva} \end{aligned}$$

at 90.4 percent power factor lagging.

Case 2 of Table 8 illustrates the great improvement in regulation possible by the use of shunt capacitors. They may have to be partially switched off at light load to prevent overvoltages under that condition. Comparing the reduction in drops caused by capacitors at D , with the reductions caused by capacitors at B and C , it can be seen that the capacitors are much more effective at the latter two points which are farther from the generating station.

Single and Multiple-Source System Having Shunt Branches Other Than Loads—Figs. 36(a) and (b) give a simple illustration of a system having shunt branches other than loads, namely charging capacity of high-voltage lines or cables. In this case the no-load voltages E_a' and E_b' of Fig. 36(c) differ from point-to-point in the system and also differ from the generator bus voltage E_g . If there are several sources, a similar condition exists. However, in either case the no-load voltages can be determined by measurement on a network calculator or by calculation and these form the base from which drops are deducted to determine voltages under load conditions by Eqs. (169) to (171). If the generator emfs vary in phase or magnitude for different parts of the study, the no-load voltages must be changed accordingly.

Fig. 36(f) shows the arrangement of the network for calculation or measurement of Z_{aa} and Z_{ab} . Sufficient voltage is applied between a and the bus of no-voltage to draw one ampere, all generator emfs being short circuited. The voltage required, using the reference direction shown in Fig. 36(f), is $-Z_{aa}$. It is thus necessary to amend the definitions of Z_{aa} and Z_{ab} given previously to the following:

Z_{aa} is the vector voltage drop from g to a caused by unit current drawn from the network at a , with all generator emfs set equal to zero.

Or it is the incremental vector drop in voltage at a per ampere drawn from a , with all generator emfs fixed in magnitude and position and all other load currents held constant.

Z_{ab} is the vector voltage drop from g to b caused by unit current drawn from the network at a , with all generator emfs set equal to zero.

The voltages and currents in Fig. 36(f) and (g) are labeled in accordance with these definitions. Increasing in ratio of actual load currents, parts (d) and (e) are obtained. Part (c) is the no-load condition. The superposition of (c), (d), and (e) results in currents identical with part (b). Consequently, the voltages E_a and E_b in

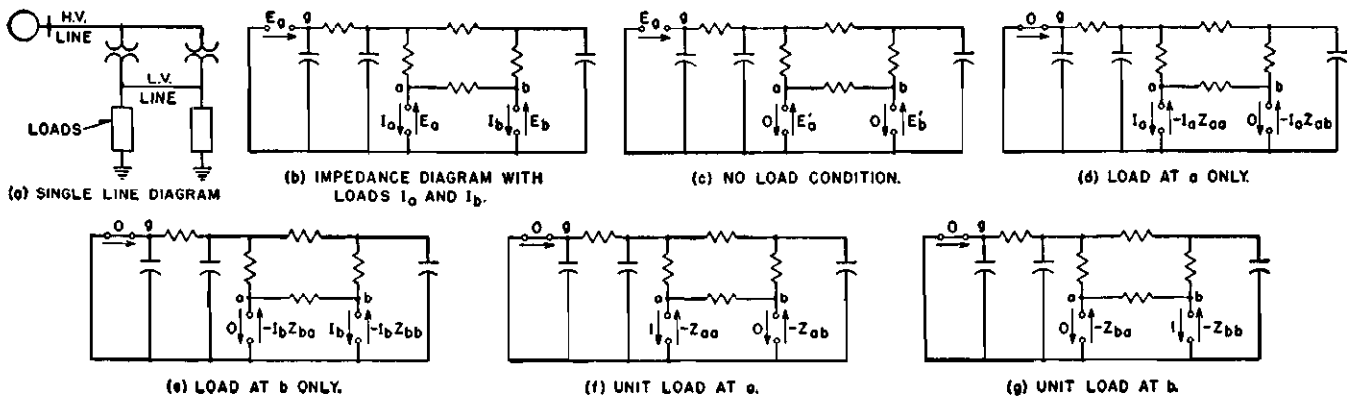

Fig. 36—Single-source system having shunt branches other than loads.

part (b) must be the superposition of the corresponding quantities in (c), (d), and (e), as stated in Eq. (168) generally. Specifically

$$E_a = E_a' - I_a Z_{aa} - I_b Z_{ba} \quad (173)$$

$$E_b = E_b' - I_a Z_{ab} - I_b Z_{bb} \quad (174)$$

It is apparent that the case of no shunt branches is simply a special case of the situation with shunt branches. Also the case of one emf is a special case of that with several. However, without shunt branches it is customary to apply enough voltage at the generator to cause one ampere in a short circuit at the load point and determine the drops through the network from generator to load points to obtain the constants Z_{aa} , Z_{ab} , etc. With shunt branches present this is no longer a series circuit from generator to load point. In this case the voltage must be applied at the load point and the generator emfs short circuited, or else an indirect method employed as described below.

With several emfs and shunt branches the network constants can be obtained by short circuiting one load terminal at a time, after first having measured the no-load voltages E_a' , E_b' , \dots , E_n' . Referring to Eqs. (173) and (174) this gives the condition:

$$E_a = 0 \quad (175)$$

$$I_b = 0 \quad (176)$$

$$Z_{aa} = \frac{E_a'}{I_a} \quad (177)$$

$$Z_{ab} = \frac{E_b' - E_b}{I_a} \quad (178)$$

Similarly by short circuiting b , the other constants are obtained.

$$Z_{ba} = \frac{E_a' - E_a}{I_b} \quad (179)$$

$$Z_{bb} = \frac{E_b'}{I_b} \quad (180)$$

Both measurements, that is, the no-load voltages and also the voltages and currents with one terminal short circuited, must be made with the same generator emfs. However, it is immaterial what emfs are used so that they may be taken all in phase and equal for the purpose of obtaining the system constants. This results in a different set of no-load voltages for computing system constants than the actual no-load voltages used in the system studies but simplifies calculation in some cases.

Summarizing, the general solution of a multiple source system with shunt branches consists of:

- a. Self and Mutual Drops.
- b. Current Division.

and for each set of emfs to be used in the study

- c. No-load voltages.

A suggested procedure for calculating these data is as follows. If a network calculator is used, the labor of reductions is eliminated.

- a. Apply voltage at one load point with generator emf short circuited and other load points open circuited.
- b. Reduce the resulting network to a single branch viewed from the selected load point. This branch is the self drop.

- c. Expand the network developing the current division based on one ampere drawn out at the selected load point. This current division is part of the general solution.

- d. Calculate the voltages of other load points above the bus-of-no-voltage, or neutral bus. These are negatives of the mutual drops.

- e. Perform a , b , c , and d for other load points in turn.

- f. With the load points all open circuited apply the generator emfs to be used in the study and determine the no-load voltages.

- g. Load voltages and current distribution throughout the network may now be determined for any loading condition corresponding to the generator emfs from which the no-load voltages were developed. The voltage at any load point p is given by Eq. (168).

The current in any branch, p - q is given by Eq. (166).

NOTE: Alternative methods are outlined in the following paragraphs.

More Than One Source—As Negative Load—If the generator emfs do not remain constant throughout a study, the network can be solved by treating all sources but one as load points. Determination of voltage and current conditions on the system for any loading conditions are then determined by using as the no-load voltages, those produced by the one selected source alone. These will be directly proportional to this one source voltage and hence can be varied for different conditions of the problem if that source voltage changes. A condition of the system is then completely specified by the selected source voltage and the currents drawn at all other sources and load points.

Changes in the Network—When a transformer is removed or a line opened, it is of course desirable to determine the effects without completely solving the new resulting network. Assume that the branch to be omitted or added connects between two of the cardinal points, a and c , of Fig. 37 for which network constants and current division factors are known. A solution is desired with the branch ac removed. By solution is meant the voltage at any cardinal point and the current in any branch corresponding to a particular load condition on the network. Thus the solution of the changed network for a given load condition is identical with the solution of the original network for the same load condition plus two additional loads. One of these added loads is drawn at each end of the branch to be removed from the original network. These added loads are equal and opposite to the current in the branch so that the total current drawn by the branch and added load is zero.

Suppose the load condition being solved for is I_b , I_c , I_d and the corresponding current in ac is I_{ac} . When loads I_a' and I_c' (equal to $-I_{ac}$) are added, they cause additional current in the branch ac :

$$\Delta I_{ac} = I_a' I_{a-ac} - I_c' I_{c-ac} \quad (181)$$

The total of branch and added load must equal zero.

$$I_{ac} + I_a' (I_{a-ac} - I_{c-ac}) + I_c' = 0 \quad (182)$$

whence:
$$I_a' = -\frac{I_{ac}}{1 + I_{a-ac} - I_{c-ac}} \quad (183)$$

and
$$I_c' = -I_a' \quad (184)$$

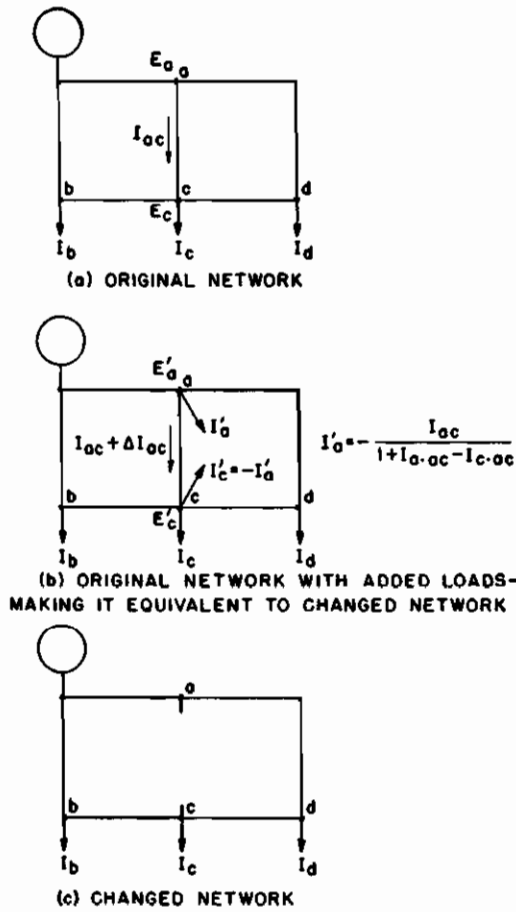

Fig. 37—Adding loads to a network to make it equivalent to the network with a branch removed.

Thus to solve the changed network for a given set of loads it is merely necessary to solve the original network instead, using the two added loads determined by Eqs. (183) and (184).

Adding a Branch Between a and c. Refer to Fig. 37 (a)—Suppose a branch is to be added between a and c having impedance Z. It can be simulated in the original network by loads equal to what the branch would carry if there. Referring to Fig. 37(b) a branch would carry:

$$I'_a = \frac{E'_a - E'_c}{Z} \tag{185}$$

where primes refer to the condition after the branch is added.

$$E'_a = E_a - I'_a Z_{aa} + I'_c Z_{ca} \tag{186}$$

$$E'_c = E_c - I'_a Z_{ac} + I'_c Z_{cc} \tag{187}$$

$$I'_a = \frac{E_a - E_c}{Z} - I'_c \left(\frac{Z_{aa} - 2Z_{ac} + Z_{cc}}{Z} \right) \tag{188}$$

$$I'_a = \frac{E_a - E_c}{Z_{aa} - 2Z_{ac} + Z_{cc} + Z} = \frac{D_c - D_a}{Z_{aa} - 2Z_{ac} + Z_{cc} + Z} \tag{189}$$

That is, the effect on the voltages and currents in Fig. 37(a), of adding a branch of impedance, Z, between a and c, while holding the generator emf and the load currents I_b , I_c , and I_d constant, is exactly the same as if

the loads I'_a and $-I'_a$ were added at a and c respectively, instead of connecting the impedance Z.

A branch Z can be removed by adding an impedance branch, $-Z$, as alternative to the method previously given.

Example of Changing a Network—A partial solution of the network of Fig. 38 follows:

$Z_{aa} = 2.5$ ohms	$I_{a-ac} = -0.25$ amperes
$Z_{ac} = 1.75$ ohms	$I_{a-ba} = 0.75$ amperes
$Z_{cc} = 2.875$ ohms	$I_{c-ac} = 0.375$ amperes
	$I_{c-ba} = 0.375$ amperes

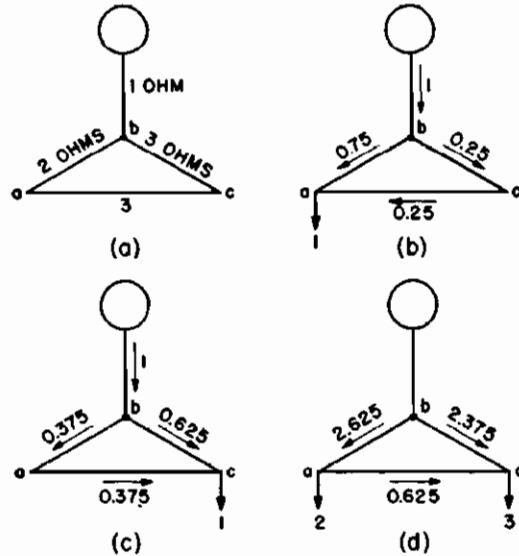

Fig. 38—A simple network showing loads and distribution factors.

From this solution the currents and voltage drops for the load condition, Fig. 38(d), are obtained.

$$I_{ba} = 2 \times 0.75 + 3 \times 0.375 = 2.625 \text{ amperes}$$

$$I_{ac} = 2 \times (-0.25) + 3 \times 0.375 = 0.625 \text{ amperes}$$

$$D_a = 2 \times 2.5 + 3 \times 1.75 = 10.25 \text{ volts}$$

$$D_c = 2 \times 1.75 + 3 \times 2.875 = 12.125 \text{ volts}$$

Now consider the changed network Fig. 39(a) under the same load condition. Solving directly:

$$I'_{ba} = 2 \text{ amperes}$$

$$I'_{ac} = 0 \text{ amperes}$$

$$D'_a = 2 \times 2 + 5 \times 1 = 9 \text{ volts}$$

$$D'_c = 3 \times 3 + 5 \times 1 = 14 \text{ volts}$$

However, suppose it were desired to obtain these data from the solution of the network, Fig. 38. Then using Eq. (183):

$$I'_a = - \frac{I_{ao}}{1 + I_{a,ao} - I_{c,ao}}$$

$$= - \frac{0.625}{1 - 0.25 - 0.375} = -1.66 \text{ amperes}$$

$$I'_c = -I'_a = 1.66 \text{ amperes.}$$

Fig. 39(b) shows these loads added to the network loads of 2 and 3 amperes at a and c.

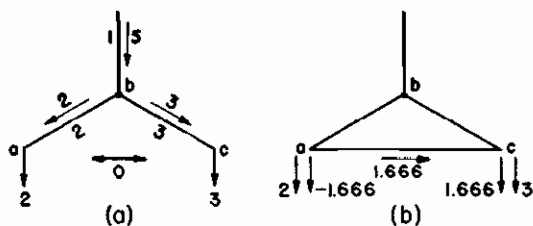

Fig. 39—Network of Fig. 38 changed by the removal of branch *ac* and its equivalent.

$$I'_{a'c} = 0.33 \times (-0.25) + 4.66 \times 0.375 = 1.66 \text{ amperes.}$$

Thus it is seen the added loads and the current in branch *ac* total zero, and can be eliminated.

That is: $I'_{a'c} + I'_a = 1.66 - 1.66 = 0$

Proceeding with the solution.

$$I'_{b'a} = 0.33 \times 0.75 + 4.66 \times 0.375 = 2.0 \text{ amperes}$$

$$D'_a = 0.33 \times 2.5 + 4.66 \times 1.75 = 9.0 \text{ volts}$$

$$D'_c = 0.33 \times 1.75 + 4.66 \times 2.875 = 14.0 \text{ volts.}$$

All of these agree with the direct solution. I'_a could also be obtained from the consideration of adding a -3 ohm branch from *a* to *c*. Eq. (189) gives

$$I'_a = \frac{D_c - D_a}{Z_{aa} - 2Z_{ac} + Z_{cc} + Z} = \frac{12.125 - 10.25}{2.5 - 3.5 + 2.875 - 3} = -1.66 \text{ amperes.}$$

and the remaining solution is the same as above.

Intermediate Loads—It frequently happens that regulation and current division are required at loads connected along branches intermediate between two cardinal points, such as the load at *x*, a fractional distance, *m*, along impedance branch *Z* from *a* to *b*, Fig. 40.

To determine regulation at *x* proceed as follows:

- Replace I_x by two loads $(1-m)I_x$ at *a* and mI_x at *b*, as shown in Fig. 40(b). From these and the other loads on the system, the voltages at *a* and *b* can be determined and a circulating current I_{ab} found.
- Permit the currents $(1-m)I_x$ and mI_x to flow over the branch to point *x* and into the load. This will not alter the drop from *a* to *b* since the two added drops introduced into this branch are equal and opposite.

$$(1-m)I_x mZ = mI_x(1-m)Z \tag{190}$$

Nor will it alter the circulating current I_{ab} that causes the drop through *Z* and absorbs the voltage difference between *a* and *b*. The drop can now be calculated from either *a* or *b* to the load point, taking into account both circulating and load components of current.

$$D_{ax} = (1-m)I_x mZ + I_{ab} mZ \tag{191}$$

Or the voltage at *x* is:

$$E_x = (1-m)E_a + mE_b - I_x m(1-m)Z \tag{192}$$

- The use of equivalent loads at *a* and *b* [Fig. 40(b)] results in the same currents in all other branches of

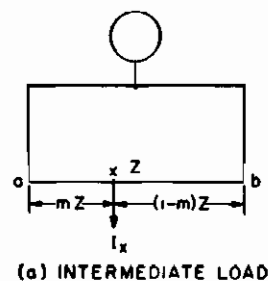

(a) INTERMEDIATE LOAD

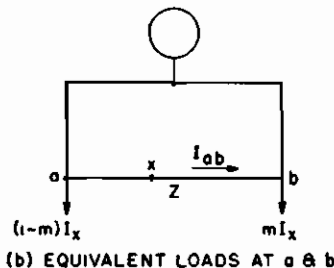

(b) EQUIVALENT LOADS AT *a* & *b*

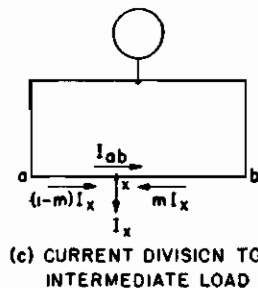

(c) CURRENT DIVISION TO INTERMEDIATE LOAD

Fig. 40—Current division for a simple network with a single intermediate load.

the network as the actual condition [Fig. 40(a)]. The currents in branch *ab* are determined as shown in Fig. 40(c), in which I_{ab} is as determined from the equivalent loading, Fig. 40(b).

General Solution for Intermediate Point—The intermediate load location is to be treated as a new cardinal point of the network for which self and mutual drop constants and current division factors are required.

The self drop constant is obtained by recalling that for unit load at *x*, Fig. 40, the drops to *a* and *b* are

$$D_a = (1-m)Z_{aa} + mZ_{ba} \tag{193}$$

$$D_b = (1-m)Z_{ab} + mZ_{bb} \tag{194}$$

whence:

$$Z_{xx} = (1-m)D_a + mD_b + m(1-m)Z \tag{195}$$

or
$$Z_{xx} = (1-m)^2 Z_{aa} + 2m(1-m)Z_{ab} + m^2 Z_{bb} + m(1-m)Z \tag{196}$$

The mutual drop constant to a typical point, *p*, is

$$Z_{xp} = (1-m)Z_{ap} + mZ_{bp} \tag{197}$$

The current in any branch *pq* caused by unit current drawn at *x* is (except for branches *ax* and *bx*):

$$I_{x-pq} = (1-m)I_{a-pq} + mI_{b-pq} \tag{198}$$

For branches *ax* and *xb*

$$I_{x-ax} = (1-m)I_{a-ab} + mI_{b-ab} + (1-m) \tag{198a}$$

$$I_{x-bx} = (1-m)I_{a-ab} + mI_{b-ab} - m \tag{198b}$$

While for point y , external to branch ab ,

$$I_{y,ax} = I_{y,xb} = I_{y,ab} \tag{198c}$$

Several Intermediate Loads—If the branch ab consists of several parallel mutually coupled circuits such as the trolley rail circuits of a four-track railroad, and contains several intermediate loads, the procedure is quite similar to the above. Refer to Fig. 41.

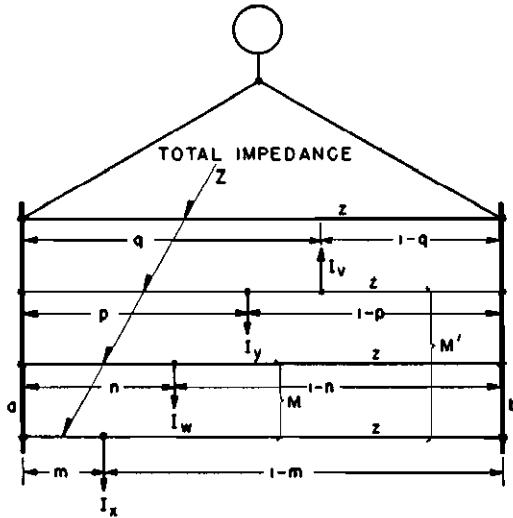

Fig. 41—More complex network having several intermediate load points.

Let Z be the total impedance a to b .
 Let z be the impedance of each component circuit.
 Let M, M', M'' be the mutual impedances between component circuits.

It is assumed that these impedances are uniform throughout the section.

The procedure is as follows for determining voltage at the load I_x , and current distribution.

- Divide each load inversely as the impedance to the two adjacent points a and b , to obtain total equivalent loads. From these and the other network loads the voltages E_a and E_b can be determined. The total circulating current I_{ab} can also be found.
- Determine the voltage at x while the loads are removed to a and b . It is:

$$E_x = (1-m)E_a + mE_b \tag{199}$$

- Now reintroduce the equivalent load currents letting them flow over the circuits to their respective loads. In the case shown there are four added drops, resulting in a voltage at the load I_x :

$$E_x = (1-m)E_a + mE_b - (1-m)I_x mz - (1-n)I_w mM - (1-p)I_y mM' - (1-q)I_v mM' \tag{200}$$

- The circulating current I_{ab} should be divided between the four circuits as though the loads were not present. If the mutual impedances are nearly equal it may be sufficiently close to assume $1/4$ of the total in each circuit. Otherwise a solution by equations may be required. See Sec. 13.

- The current in any section of one of the circuits of branch ab consists of the vector sum of the circulating component as determined in (d), and the reintroduced equivalent load currents flowing up to the intermediate loads.

21. Circle Diagram of Transmission Systems

Because of its importance to both the light and power and the communication industries, the transmission type network has been widely studied. A useful body of data is available for simplifying the calculations and expressing the performance of such networks. The fundamental ideas involved are extremely simple, and the reader should not be misled by the large accumulation of formulas tabulated for special cases. These merely signify that the field has been well explored, whereas only one or two of the formulas may be required in any particular problem.

The general transmission-type network including shunt loading, is one having only input and output terminals of importance, designated for convenience as the sending and receiving ends. The type dealt with in this chapter is considered to be passive (having no internal emfs), and linear (made up of linear impedance branches and voltage transformations).

For such a network the sending-end voltage and current depend solely on the receiving-end voltage and current, and the impedances and voltage transformations of the intervening network.

The transmission problem is briefly the determination of the performance of the transmission-type network. This performance is most commonly expressed in two forms.

- Equations expressing the sending-end voltages and currents in terms of the receiving-end voltages and currents, and vice versa.
- The power equations or loci, the graphical representations of which are known as the power circle diagrams. One circle gives the locus of sending-end power and one the locus of receiving-end power, as the angle between sending and receiving voltages is varied.

A third form is sometimes used.

- The current equations expressing the sending-end or receiving-end currents in terms of the voltages at the two ends. The current locus for fixed voltages and varying angle between them is the current circle diagram.

Power Circle Diagram—The power-circle diagram is derived mathematically in Chap. 9. The treatment in this chapter applies the diagram to general system problems. Condensed tables are presented for determining the circle diagrams from general circuit constants. First, however, a brief review of the power-circle diagram will serve to point up the important power system design and operating information which it provides.

The fact that real and reactive power fed into and out of a transmission line can be plotted as a function of the sending- and receiving-end voltages only is itself an extremely important concept. Stated differently, once the voltage magnitudes at the two ends of the line have been fixed, there exists for each angle between these voltages, one and only one possible value for each of the four quan-

each angle there will be a discrete value of input real and reactive power. If these are plotted, one against the other, on a set of coordinate axes having real power as abscissa and reactive power as ordinate, the locus of such points as the angle between voltages is varied is a circle. Thus this plot of real power vs. reactive power for fixed line voltages and varying angle, is called a power circle diagram. What has been said of input real and reactive power applies equally well to output real and reactive power. Hence, for a given pair of terminal voltages there are two circle diagrams, a sending-end circle and a receiving-end circle. For other voltages there are other circles. The fact that these diagrams are circles makes them easy to draw. However the important point is that the input and output real and reactive powers are uniquely determined by the terminal voltages and the angle between them. In a sense this places definite restrictions on the use of lines. Or from another viewpoint it makes it possible to predetermine the amount of synchronous-condenser capacity that is required to supply a given load over a given line.

These points may be made more clear by reference to Fig. 46 which shows the sending-end and receiving-end power-circle diagrams for two values of sending-end voltage and one value of receiving-end voltage, i.e. for two combinations. Thus there are four circles. The method of plotting these circles and the derivation has been given in Chap. 9, and will be summarized shortly for the general case. That need not concern us here. Suffice it to say that there are such plots. What do they show?

The coordinates of the plot are real power as abscissa, positive to the right and lagging-reactive power as ordinate, positive upwards. The two sending end circles, have their centers at B and B' in the first quadrant. The positive reference direction at the sending end is into the line. Thus positive real or reactive power flow into the line at this end.

The two lower circles having centers at A , in the third quadrant, are the receiving-end circles. At the receiving end the positive reference direction is out of the line. Thus positive real and reactive power from the receiving circles indicate real or reactive power out of the line and a negative sign of reactive power indicates that lagging reactive power flowed into the line at the receiving end.

Note first there is a maximum power that can be delivered, for example 57 771 kw for one set of voltages, $E_R = 127\ 020$ and $E_S = 129\ 917$ volts L-N. This is of course an absolute limit and well beyond a practical operating limit.

It has been stated that with fixed voltages there exists for each angle between them, one and only one possible value of each of the four power quantities. This is shown on the diagram, for example, for an angle of $23^\circ 20' 59''$, and for the voltages $E_R = 127\ 020$, $E_S = 129\ 917$ volts L-N. Note that the angles are measured out from reference lines, marked Line for $\theta = 0$, whose construction will be described later. The angle θ , by which the sending-end voltage leads the receiving end voltage is measured out ccw for the upper or sending circles and cw for the lower or receiving-end circles. Thus this specific angle fixes the points F and G on receiving and sending circles respectively. These are referred to as corresponding points, since they correspond to the same angle and hence give sending- and receiving-end conditions that occur simultaneously.

For this angle and these voltages note that 27 595 kw enters the line and 25 835 kw leaves it at the receiving end, the loss being 1760 kw. At the sending-end lagging reactive kva is negative and hence flows opposite to the reference positive direction. That is, lagging reactive kva flows out of the line, 7620 kva. This must be absorbed by the system at the sending end of the line, in inductive loads or by under-excited machines. At the receiving end lagging reactive kva is positive and hence flows in the reference direction for that end which is out of the line, 2270 kva. In general this may be more or less than the lagging reactive requirements of the load and the difference must be absorbed or supplied locally. For example, if the load were 25 835 kw at 83.26 percent power factor lag as plotted at E , requiring 17 258 lagging reactive kva, the difference of 14 988 kva would have to be supplied by a synchronous condenser operating in its over-excited range, or an equivalent.

If the load is increased to an emergency load of 52 335 kw at 84.78 percent power factor lagging, the corresponding points on the circles are at J and K . It is assumed that the sending-end voltage has been raised to 137 523 volts L-N for this condition. The condenser must now supply 52 461 kva of lagging reactive, as the line supplies a negative amount or actually draws lagging reactive. Note that to supply this load with the lower sending voltage would have required considerably more than the 52 461 kva from the condenser.

Other circles could be drawn for different receiver voltages and these would show the variation of synchronous-condenser capacity requirements within the limits of permissible variation of receiver-end voltage.

Thus the circle diagram presents a complete graphical picture of the line performance under all conditions of terminal voltages and angles and hence provides the necessary information for design and operation of the system, particularly with relation to voltages, provision of reactive capacity, and real power flow.

Transmission Equations: Constructing the Circle Diagram

Generally the following steps are involved in determining the transmission characteristics of a system from one point to another.

- a. The network must be reduced to a simple equivalent from which the constants for plotting the circle diagrams can be obtained. The simple equivalent can be expressed as a T or a Π circuit or by giving the coefficients of the current and voltage equations, called the $ABCD$ constants. Table 9 gives the necessary formulas for determining the $ABCD$ constants directly from networks of various forms. The T and Π equivalents can be obtained by reducing the network as outlined in Secs. 13–17, or as indicated by the definitions of these constants which are to follow. Table 10 gives the transformations from Π to T and to $ABCD$ forms. This table also includes transformations to admittance and impedance constants that are coefficients of the power equations as shown in the table.
- b. The Current and Voltage Relations if needed can be written directly from the T , Π or $ABCD$ constants

TABLE 9—GENERAL CIRCUIT CONSTANTS FOR DIFFERENT TYPES OF NETWORKS⁵

Net- work number	Type of Network	Equations for general circuit constants in terms of constants of component networks			
		A =	B =	C =	D =
1	Series impedance	1	Z	0	1
2	Shunt admittance	1	0	Y	1
3	Transformer	$1 + \frac{Z_T Y_T}{2}$	$Z_T \left(1 + \frac{Z_T Y_T}{4}\right)$	Y_T	$1 + \frac{Z_T Y_T}{2}$
3a	Transformer Ratio	$\frac{1}{N}$	0	0	N
4	Transmission line	$\text{Cosh } \sqrt{ZY} = \left(1 + \frac{ZY}{2} + \frac{Z^2 Y^2}{24} + \dots\right)$	$\sqrt{Z/Y} \text{ Sinh } \sqrt{ZY} = Z \left(1 + \frac{ZY}{6} + \frac{Z^2 Y^2}{120} + \dots\right)$	$\sqrt{Y/Z} \text{ Sinh } \sqrt{ZY} = Y \left(1 + \frac{ZY}{6} + \frac{Z^2 Y^2}{120} + \dots\right)$	Same as A
5	General network	A	B	C	D
6	General network and transformer impedance at receiving end	A ₁	B ₁ + A ₁ Z _{TR}	C ₁	D ₁ + C ₁ Z _{TR}
7	General network and transformer impedance at sending end	A ₁ + C ₁ Z _{TR}	B ₁ + D ₁ Z _{TR}	C ₁	D ₁
8	General network and transformer impedance at both ends—referred to high voltage	A ₁ + C ₁ Z _{TR}	B ₁ + A ₁ Z _{TR} + D ₁ Z _{TR} + C ₁ Z _{TR} Z _{TR}	C ₁	D ₁ + C ₁ Z _{TR}
9	General network and transformer impedance at both ends—transformers having different ratios T _R and T _S referred to low voltage	$\frac{T_R}{T_S} (A_1 + C_1 Z_{TR})$	$\frac{1}{T_R T_S} (B_1 + A_1 Z_{TR} + D_1 Z_{TR} + C_1 Z_{TR} Z_{TR})$	C ₁ T _R T _S	$\frac{T_S}{T_R} (D_1 + C_1 Z_{TR})$
10	General network and shunt admittance at receiving end	A ₁ + B ₁ Y _R	B ₁	C ₁ + D ₁ Y _R	D ₁
11	General network and shunt admittance at sending end	A ₁	B ₁	C ₁ + A ₁ Y _S	D ₁ + B ₁ Y _S
12	General network and shunt admittance at both ends	A ₁ + B ₁ Y _R	B ₁	C ₁ + A ₁ Y _S + D ₁ Y _R + B ₁ Y _R Y _S	D ₁ + B ₁ Y _S
13	Two general networks in series	A ₁ A ₂ + C ₁ B ₂	B ₁ A ₂ + D ₁ B ₂	A ₁ C ₂ + C ₁ D ₂	B ₁ C ₂ + D ₁ D ₂
14	Two general networks in series with intermediate impedance	A ₁ A ₂ + C ₁ B ₂ + C ₁ A ₂ Z	B ₁ A ₂ + D ₁ B ₂ + D ₁ A ₂ Z	A ₁ C ₂ + C ₁ D ₂ + C ₁ C ₂ Z	B ₁ C ₂ + D ₁ D ₂ + D ₁ C ₂ Z
15	Two general networks in series with intermediate shunt admittance	A ₁ A ₂ + C ₁ B ₂ + A ₁ B ₂ Y	B ₁ A ₂ + D ₁ B ₂ + B ₁ B ₂ Y	A ₁ C ₂ + C ₁ D ₂ + A ₁ D ₂ Y	B ₁ C ₂ + D ₁ D ₂ + B ₁ D ₂ Y
16	Three general networks in series	A ₃ (A ₁ A ₂ + C ₁ B ₂) + B ₃ (A ₁ C ₂ + C ₁ D ₂)	A ₃ (B ₁ A ₂ + D ₁ B ₂) + B ₃ (B ₁ C ₂ + D ₁ D ₂)	C ₃ (A ₁ A ₂ + C ₁ B ₂) + D ₃ (A ₁ C ₂ + C ₁ D ₂)	C ₃ (B ₁ A ₂ + D ₁ B ₂) + D ₃ (B ₁ C ₂ + D ₁ D ₂)
17	Two general networks in parallel	$\frac{A_1 B_2 + B_1 A_2}{B_1 + B_2}$	$\frac{B_1 B_2}{B_1 + B_2}$	$\frac{C_1 + C_2 + (A_1 - A_2)(D_2 - D_1)}{B_1 + B_2}$	$\frac{B_1 D_2 + D_1 B_2}{B_1 + B_2}$

NOTE. The exciting current of the receiving end transformers should be added vectorially to the load current, and the exciting current of the sending end transformers should be added vectorially to the sending end current.
 General equations: $E_S = E_R A + I_R B$; $E_R = E_S D - I_S B$; $I_S = I_R D + E_R C$; $I_R = I_S A - E_S C$. As a check in the numerical calculation of the A, B, C, and D constants note that in all cases $AD - BC = 1$ unless there is a net angular transformation ratio. In the latter case $AD - BC = 1e^{j\theta}$ where θ is the angular transformation of S ahead of R. See Sec. 8.

TABLE 10—CONVERSION FORMULAS FOR TRANSMISSION TYPE NETWORKS

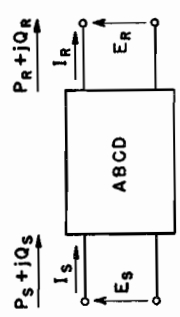
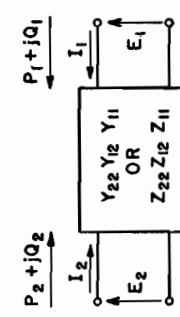
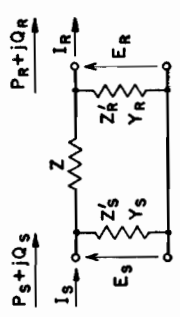
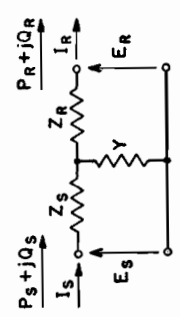
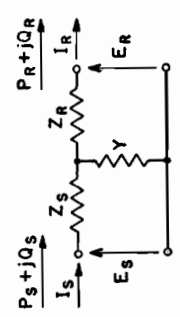
		To Convert From				Reference Directions and Nomenclature	
		ABCD Constants	Admittance	Impedance	Equivalent Pi	Equivalent T	
A =	ABCD	$\begin{aligned} ABCD \text{ Constants} \\ E_S = AE_R + BI_R \\ I_S = CE_R + DI_R \\ E_R = DE_S - BI_S \\ I_R = -CE_S + AI_S \end{aligned}$	$\begin{aligned} \frac{Y_{11}}{-Y_{12}} \\ \frac{1}{-Y_{12}} \\ \frac{Y_{12}^2 - Y_{11}Y_{22}}{Y_{12}} \\ \frac{Y_{22}}{-Y_{12}} \end{aligned}$	$\begin{aligned} \frac{Z_{22}}{Z_{12}} \\ \frac{Z_{11}Z_{22} - Z_{12}^2}{Z_{12}} \\ \frac{1}{Z_{12}} \\ \frac{Z_{11}}{Z_{12}} \end{aligned}$	$\begin{aligned} 1 + ZY_R \\ Z \\ Y_R + Y_S + ZY_R Y_S \\ 1 + ZY_S \end{aligned}$	$\begin{aligned} 1 + Z_S Y \\ Z_R + Z_S + YZ_R Z_S \\ Y \\ 1 + Z_R Y \end{aligned}$	 <p>Fig. 42</p>
B =							
C =							
D =							
Y ₁₁ =	Admittance	$\begin{aligned} \frac{A}{B} \\ \frac{1}{-B} \\ \frac{D}{B} \end{aligned}$	Admittance Constants $\begin{aligned} I_1 = Y_{11}E_1 + Y_{12}E_2 \\ I_2 = Y_{12}E_1 + Y_{22}E_2 \end{aligned}$	$\begin{aligned} \frac{Z_{22}}{Z_{11}Z_{22} - Z_{12}^2} \\ \frac{Z_{12}}{-Z_{11}Z_{22} - Z_{12}^2} \\ \frac{Z_{11}}{Z_{11}Z_{12} - Z_{12}^2} \end{aligned}$	$\begin{aligned} \frac{1}{Y_R + Z} \\ -\frac{1}{Z} \\ \frac{1}{Y_S + Z} \end{aligned}$	$\begin{aligned} \frac{1 + Z_S Y}{Z_R + Z_S + YZ_R Z_S} \\ \frac{1}{-Z_R + Z_S + YZ_R Z_S} \\ \frac{1 + YZ_R}{Z_R + Z_S + YZ_R Z_S} \end{aligned}$	 <p>Fig. 43</p>
Y ₁₂ =							
Y ₂₂ =							
Z ₁₁ =	Impedance	$\begin{aligned} \frac{D}{C} \\ \frac{1}{C} \\ \frac{A}{C} \end{aligned}$	$\begin{aligned} \frac{Y_{22}}{Y_{11}Y_{22} - Y_{12}^2} \\ -\frac{Y_{12}}{Y_{11}Y_{22} - Y_{12}^2} \\ \frac{Y_{11}}{Y_{11}Y_{22} - Y_{12}^2} \end{aligned}$	Impedance Constants $\begin{aligned} E_1 = Z_{11}I_1 + Z_{12}I_2 \\ E_2 = Z_{12}I_1 + Z_{22}I_2 \end{aligned}$	$\begin{aligned} \frac{1 + ZY_S}{Y_R + Y_S + ZY_R Y_S} \\ \frac{1}{Y_R + Y_S + ZY_R Y_S} \\ \frac{1 + ZY_R}{Y_R + Y_S + ZY_R Y_S} \end{aligned}$	$\begin{aligned} \frac{1}{Z_R + Y} \\ \frac{1}{Y} \\ Z_S + Y \end{aligned}$	 <p>Fig. 44</p>
Z ₁₂ =							
Z ₂₂ =							
Y _R =	Equip. Pi	$\begin{aligned} \frac{A-1}{B} \\ B \\ \frac{D-1}{B} \end{aligned}$	$\begin{aligned} Y_{11} + Y_{12} \\ -\frac{1}{Y_{12}} \\ Y_{22} + Y_{12} \end{aligned}$	$\begin{aligned} \frac{Z_{22} - Z_{12}}{Z_{11}Z_{22} - Z_{12}^2} \\ \frac{Z_{11}Z_{22} - Z_{12}^2}{Z_{12}} \\ \frac{Z_{11} - Z_{12}}{Z_{11}Z_{22} - Z_{12}^2} \end{aligned}$	Equivalent Pi	$\begin{aligned} \frac{YZ_S}{Z_R + Z_S + YZ_R Z_S} \\ \frac{Z_R + Z_S + YZ_R Z_S}{YZ_R} \\ \frac{1}{Z_R + Z_S + YZ_R Z_S} \end{aligned}$	 <p>Fig. 45</p>
Z =							
Y _S =							
Z _R =	Equip. T	$\begin{aligned} \frac{D-1}{C} \\ C \\ \frac{A-1}{C} \end{aligned}$	$\begin{aligned} \frac{Y_{22} + Y_{12}}{Y_{11}Y_{22} - Y_{12}^2} \\ -\frac{Y_{11}Y_{22} - Y_{12}^2}{Y_{12}} \\ \frac{Y_{11} + Y_{12}}{Y_{11}Y_{12} - Y_{12}^2} \end{aligned}$	$\begin{aligned} Z_{11} - Z_{12} \\ \frac{1}{Z_{12}} \\ Z_{22} - Z_{12} \end{aligned}$	Equivalent T	$\begin{aligned} \frac{YZ_S}{Z_R + Z_S + YZ_R Z_S} \\ \frac{Z_R + Z_S + YZ_R Z_S}{YZ_R} \\ \frac{1}{Z_R + Z_S + YZ_R Z_S} \end{aligned}$	
Y =							
Z _S =							

To Convert To

TABLE 11—CURRENT AND VOLTAGE RELATIONS IN TRANSMISSION TYPE NETWORKS

A. For <i>ABCD</i> Constants—Reference Fig. 42.*	
$E_S = AE_R + BI_R$	(201a)
$I_S = CE_R + DI_R$	(201b)
$E_R = DE_S - BI_S$	(201c)
$I_R = -CE_S + AI_S$	(201d)
B. For Equivalent Pi—Reference Fig. 44.	
$E_S = (1 + ZY_R)E_R + ZI_R$	(202a)
$I_S = (Y_R + Y_S + ZY_R Y_S)E_R + (1 + ZY_S)I_R$	(202b)
$E_R = (1 + ZY_S)E_S - ZI_S$	(202c)
$I_R = -(Y_R + Y_S + ZY_R Y_S)E_S + (1 + ZY_R)I_S$	(202d)
C. For Equivalent T—Reference Fig. 45.	
$E_S = (1 + Z_S Y)E_R + (Z_R + Z_S + YZ_R Z_S)I_R$	(203a)
$I_S = Y E_R + (1 + Z_R Y)I_R$	(203b)
$E_R = (1 + Z_R Y)E_S - (Z_R + Z_S + YZ_R Z_S)I_S$	(203c)
$I_R = -Y E_S + (1 + Z_S Y)I_S$	(203d)
D. For Admittance—Reference Fig. 43.	
$I_1 = Y_{11} E_1 + Y_{12} E_2$	(203e)
$I_2 = Y_{12} E_1 + Y_{22} E_2$	(203f)
E. For Impedance—Reference Fig. 43.	
$E_1 = Z_{11} I_1 + Z_{12} I_2$	(203g)
$E_2 = Z_{12} I_1 + Z_{22} I_2$	(203h)

*Figs. 42 to 45 are part of Table 10.

as shown in Table 11. Frequently these are not needed.

c. The Power Expressions are given in Table 12 in terms of the *T*, Pi, or *ABCD* constants and also in terms of admittance and impedance coefficients, which are described in a later paragraph. The power convention used in this text is:

$$P + jQ = EI \tag{212}$$

for which a positive value of *Q* is lagging reactive power, and *P* and *Q* of the same sign indicates lagging power factor (see Sec. 2). At the sending end, denoted by the subscript, *S*, the positive direction is into the network. At the receiving end, denoted by *R*, it is out of the network. See Figs. 42, 44, 45 which are part of Table 10. With the generalized impedance or admittance form, Fig. 43, the reference-positive direction for current and power at each terminal is into the line or network.

d. The Power Circle Diagrams can be determined from the data in Table 12 as outlined at the bottom of the table. The detailed data for plotting the circles can be obtained from the supplementary Table 12A, explained in the next paragraph.

TABLE 12—POWER EQUATIONS AND DATA FOR PLOTTING CIRCLE DIAGRAMS

Derived From	Sending Circle		Receiving Circle	
	Vector to Center, C_s	Radius Vector R_{S0}	Vector to Center, C_R	Radius Vector R_{R0}
<i>ABCD</i> Ref. Fig. 42	$P_S + jQ_S = 3 \frac{\hat{D}}{B} \bar{E}_S^2$	$-\frac{3}{B} \bar{E}_R E_S \epsilon^{+j\theta}$	$P_R + jQ_R = -3 \frac{\hat{A}}{B} \bar{E}_R^2$	$+\frac{3}{B} \bar{E}_R E_S \epsilon^{-j\theta}$
		(204)		(205)
Equiv. Pi Ref. Fig. 44	$P_S + jQ_S = 3 \left(\frac{1}{Z} + \hat{Y}_S \right) \bar{E}_S^2$	$-\frac{3}{Z} \bar{E}_R E_S \epsilon^{+j\theta}$	$P_R + jQ_R = -3 \left(\frac{1}{Z} + \hat{Y}_R \right) \bar{E}_R^2$	$+\frac{3}{Z} \bar{E}_R E_S \epsilon^{-j\theta}$
		(206)		(207)
Imped. Form Equiv. Pi Ref. Fig. 44	$P_S + jQ_S = 3 \left(\frac{1}{Z} + \frac{1}{Z'_S} \right) \bar{E}_S^2$	$-\frac{3}{Z} \bar{E}_R E_S \epsilon^{+j\theta}$	$P_R + jQ_R = -3 \left(\frac{1}{Z} + \frac{1}{Z'_R} \right) \bar{E}_R^2$	$+\frac{3}{Z} \bar{E}_R E_S \epsilon^{-j\theta}$
		(206a)		(207a)
Equiv. <i>T</i> Ref. Fig. 45	$P_S + jQ_S = \frac{3(1 + \hat{Z}_R \hat{Y}) \bar{E}_S^2}{\hat{Z}_R + \hat{Z}_S + \hat{Y} \hat{Z}_R \hat{Z}_S}$	$-\frac{3 \bar{E}_R E_S \epsilon^{+j\theta}}{\hat{Z}_R + \hat{Z}_S + \hat{Y} \hat{Z}_R \hat{Z}_S}$	$P_R + jQ_R = -\frac{3(1 + \hat{Z}_S \hat{Y}) \bar{E}_R^2}{\hat{Z}_R + \hat{Z}_S + \hat{Y} \hat{Z}_R \hat{Z}_S}$	$+\frac{3 \bar{E}_R E_S \epsilon^{-j\theta}}{\hat{Z}_R + \hat{Z}_S + \hat{Y} \hat{Z}_R \hat{Z}_S}$
		(208)		(209)
Admittance Ref. Fig. 43	$P_S + jQ_S = 3 \hat{Y}_{12} \bar{E}_S^2$	$+3 \hat{Y}_{12} \bar{E}_1 E_2 \epsilon^{+j\theta}$	$P_R + jQ_R = 3 \hat{Y}_{11} \bar{E}_R^2$	$+3 \hat{Y}_{12} \bar{E}_1 E_2 \epsilon^{-j\theta}$
		(210)		(211)
Impedance Ref. Fig. 43	$P_S + jQ_S = \frac{3 \hat{Z}_{11} \bar{E}_S^2}{\hat{Z}_{11} \hat{Z}_{22} - \hat{Z}_{12}^2}$	$-\frac{3 \hat{Z}_{12} \bar{E}_1 E_2 \epsilon^{+j\theta}}{\hat{Z}_{11} \hat{Z}_{22} - \hat{Z}_{12}^2}$	$P_R + jQ_R = \frac{3 \hat{Z}_{22} \bar{E}_R^2}{\hat{Z}_{11} \hat{Z}_{22} - \hat{Z}_{12}^2}$	$-\frac{3 \hat{Z}_{12} \bar{E}_1 E_2 \epsilon^{-j\theta}}{\hat{Z}_{11} \hat{Z}_{22} - \hat{Z}_{12}^2}$
		(210a)		(211a)

UNITS

Table gives *P* and *Q* in megawatts (mw), and megavolt amperes (mva) for E_R and E_S in kv line-to-neutral, or it gives *P* and *Q* in watts and volt-amperes for E_S and E_R in volts, line-to-neutral.

To use volts or kv line-to-line, omit factor 3 throughout the tabulation.

Impedances and admittances are in ohms or mhos per phase, line-to-neutral.

θ is the angle of E_S in advance of E_R or the angle of E_2 in advance of E_1 .

- Symbol designating conjugate of a vector.

TO DRAW CIRCLE DIAGRAM—FIG. 47

1. Calculate "vector to center" and locate center, C_S or C_R .
2. Calculate radius vector for $\theta = 0$ ($\epsilon^{-j\theta} = \epsilon^{j\theta} = 1$). Call it R_{S0} or R_{R0} .
3. Add 1 and 2 to obtain real and reactive power for sending and receiving voltages in phase. Plot this as "Power for $\theta = 0$ ", on the diagram. $W_{R0} = C_R + R_{R0}$. $W_{S0} = C_S + R_{S0}$.
4. Draw the circle through the "Power for $\theta = 0$ " point. Draw the reference radius vector from the center to the "Power for $\theta = 0$ " point, to serve as the reference from which angles are measured.
5. Corresponding sending and receiving conditions are found at the same angle on the corresponding circles.

TABLE 12A—CONSTANTS FOR PLOTTING POWER CIRCLE DIAGRAMS

Refer Fig. 47

 $(l, m, l', m', n, \theta_b)$ are to be obtained from the relations given)

Form of* System Constants	Receiving Circle Constants	Sending Circle Constants	Radius Constant	Position of Radius Vector for $\theta=0$
	$l+jm$	$l'+jm'$	n	θ_b
<i>ABCD</i> Ref. Fig. 42	$\frac{\hat{A}}{\hat{B}}$	$\frac{\hat{D}}{\hat{B}}$	$\frac{1}{\hat{B}}$	$\tan^{-1} \frac{b_1}{b_2}, B=b_1+jb_2$
Equiv. Pi Ref. Fig. 44	$\frac{1}{\hat{Z}} + \hat{Y}_R$	$\frac{1}{\hat{Z}} + \hat{Y}_S$	$\frac{1}{\hat{Z}}$	$\tan^{-1} \frac{r}{x}, Z=r+jx$
Imped. Form Equiv. Pi Ref. Fig. 44	$\frac{1}{\hat{Z}} + \frac{1}{\hat{Z}_R}$	$\frac{1}{\hat{Z}} + \frac{1}{\hat{Z}_S}$	$\frac{1}{\hat{Z}}$	$\tan^{-1} \frac{r}{x}, Z=r+jx$
Equiv. <i>T</i> Ref. Fig. 45	$\frac{1 + \hat{Z}_S \hat{Y}}{\hat{Z}_R + \hat{Z}_S + \hat{Y} \hat{Z}_R \hat{Z}_S}$	$\frac{1 + \hat{Z}_R \hat{Y}}{\hat{Z}_R + \hat{Z}_S + \hat{Y} \hat{Z}_R \hat{Z}_S}$	$\frac{1}{\hat{Z}_R + \hat{Z}_S + \hat{Y} \hat{Z}_R \hat{Z}_S}$	$\tan^{-1} \frac{b_1}{b_2}$ where $\hat{Z}_R + \hat{Z}_S + \hat{Y} \hat{Z}_R \hat{Z}_S = b_1 + jb_2$

*For admittance and impedance constants the reference direction is into the network at both ends. Thus the receiving circle is in the same quadrant as the sending circle and the l and m constants do not apply. Use the method of Table 12 for plotting the circles in this case.

Construction of power circles.—For the occasional user it is convenient to list directly the coordinates of the centers and the radii of the circles, together with the location of the reference line from which angles are to be measured. For this purpose the six constants l, m, n, θ_b, l' and m' are defined and used. When working with *ABCD* constants these have the definitions:—

$$\frac{1}{\hat{B}} = n \quad (213)$$

$$\theta_b = \tan^{-1} \frac{b_1}{b_2} \text{ where } B = b_1 + jb_2 \quad (214)$$

$$\frac{\hat{A}}{\hat{B}} = l + jm \quad (215)$$

$$\frac{\hat{D}}{\hat{B}} = l' + jm' \quad (216)$$

For other forms of expression of the transmission network the definitions of these six constants are given in Table 12A.

Having defined these six constants, the circles can be constructed as follows. Refer to Fig. 47. The scales used for mw and reactive mva must be the same. Line-to-line voltages are used, giving three-phase mw and reactive mva. If line-to-neutral voltages are used to determine the centers and radii of sending and receiving circles, the expressions in Fig. 47 must be multiplied by three.

Center of sending circle is at $l' \bar{E}_R^2$ mw, $m' \bar{E}_S^2$ mvar.

Radius of sending circle is $n \bar{E}_R \bar{E}_S$.

The reference line for angles in the sending circle is clockwise from a downward vertical radius by the angle, θ_b . See Fig. 46, Angles θ of sending-end voltage in advance of receiving-end voltage, are measured ccw from this reference line.

Center of the receiving circle is at $-l \bar{E}_R^2$ mw, $-m \bar{E}_R^2$ mvar.

Radius of the receiving circle is $n \bar{E}_R \bar{E}_S$.

The reference line for angles in the receiving circle is cw

from an upward vertical radius by the angle, θ_b . See Fig. 47.

Corresponding sending and receiving conditions are found at the same angle θ on the two corresponding circles.

An alternative method of construction is listed in the five steps under Table 12, which eliminates the necessity of measuring angles. An "initial radius vector for $\theta=0$ " is added to the "vector to the center" to get the coordinates of a point (i.e. the vector power) corresponding to $\theta=0$. This fixes both the radius and the reference line for measuring angles.

Power-Angle Diagrams—From the circle diagram the power expressions as a function of angle can be written directly. They are, for three-phase power in mw on mvar, and voltages in kv, L-L;—

$$P_S = l' \bar{E}_S^2 + n \bar{E}_R \bar{E}_S \sin(\theta - \theta_b) \quad (217)$$

$$Q_S = m' \bar{E}_S^2 - n \bar{E}_R \bar{E}_S \cos(\theta - \theta_b) \quad (218)$$

$$P_R = -l \bar{E}_R^2 + n \bar{E}_R \bar{E}_S \sin(\theta + \theta_b) \quad (219)$$

$$Q_R = -m \bar{E}_R^2 + n \bar{E}_R \bar{E}_S \cos(\theta + \theta_b) \quad (220)$$

Power plotted vertically against θ plotted horizontally is thus a displaced sine wave known as a power angle diagram. Its use in stability calculations is described in Chapter 13.

Use of Equations vs. Circle Diagrams—If only one condition were of interest, for which the voltages and intervening angle were known, the sending and receiving power quantities could be calculated directly, using the power expressions of Table 12. However, if the power transmitted is to be determined for a number of angular positions, as in stability studies, the circle diagram is advantageous. Also if the voltages and power are known and the angle and reactive requirements are to be determined the circle diagram becomes indispensable. More particularly a diagram having several circles corresponding to different voltages constitutes a chart of the real and reactive powers that can be trans-

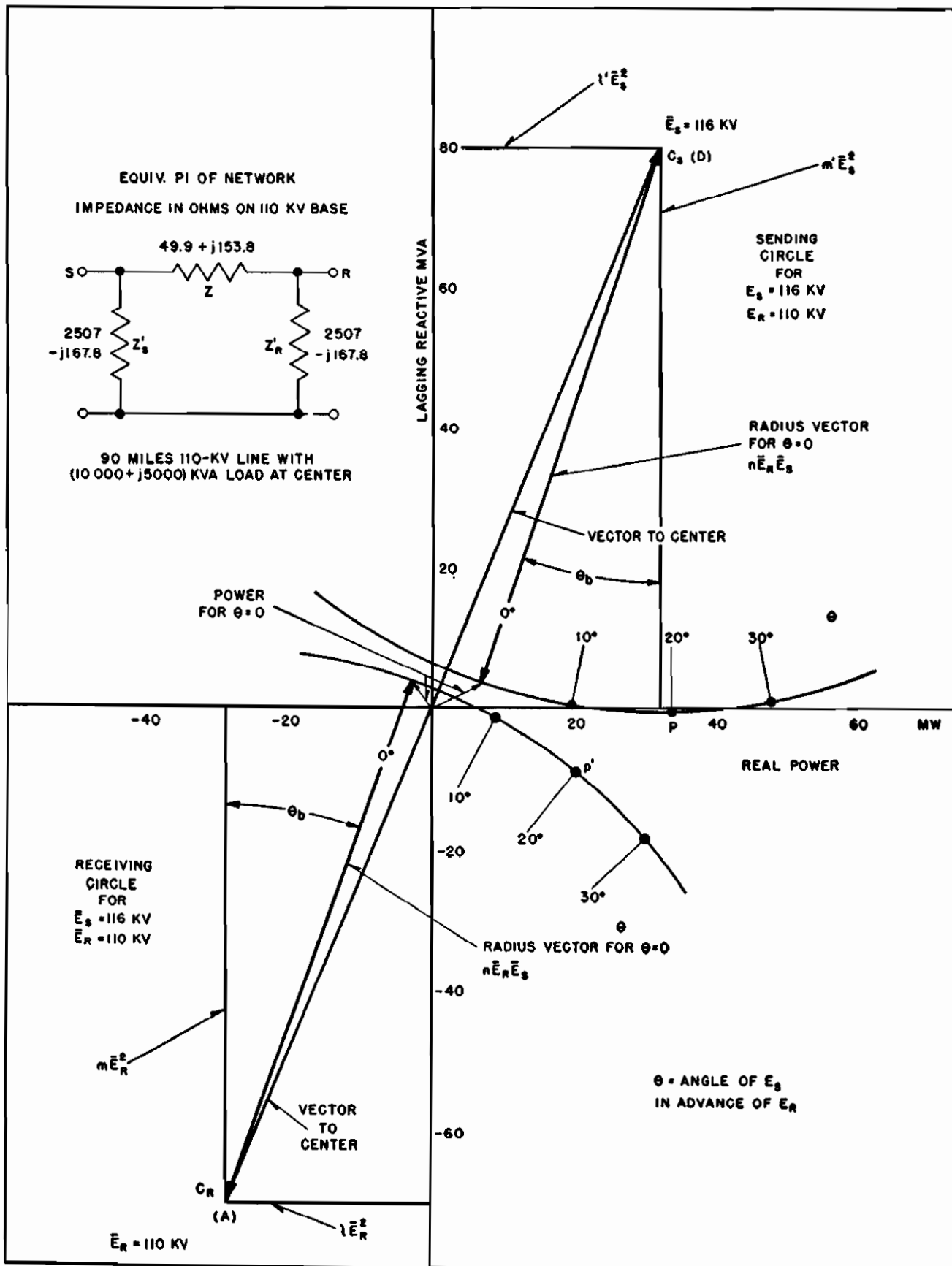

Fig. 47—Power circle diagram for line AED Fig. 48 and used for example of plotting diagram.

mitted for various voltages and angles. As such it finds extensive use both in system operation and design.

Interpretation of Power Circle Diagrams—Power circle diagrams for a particular system are given in Fig. 47. They have been drawn in accordance with the instructions at the bottom of Table 12. Likewise their construction from the six constants $l, m, n, \theta_b, l', n'$, given in Table 12A is indicated. This system consists of ninety miles of 110-kv line with a load of 10 000 kw and 5000 lagging reactive kva tapped on at the middle. The load is treated as a fixed impedance. Points p and p' convey the following information, "With a receiver voltage of 110 kv and a sending voltage 116 kv, if 34 000 kw (34 megawatts) are supplied at the sending end, then 500 leading reactive kva must be supplied at the sending end and 20 000 kw and 9000 leading reactive kva will be delivered at the receiving end. That is, 9000 kva of lagging reactive must be supplied at the receiving end. 13 500 kw and 8500 reactive kva will be consumed in the system, including line losses and reactive plus the intermediate load. Incidentally the sending-end voltage is only 20 degrees ahead of the receiving-end voltage and the operation will therefore be stable†." Obviously contained in this information are the answers to a variety of questions that might be asked.

ABCD Constants are coefficients of the current and voltage equations (201a) to (201d) given in Table 11. They apply to the transmission-type network having sending-end and receiving-end terminals, and have the following physical significance.

A is the voltage impressed at the sending end per volt at the open-circuited receiver. It is a dimensionless voltage ratio.

B is the voltage impressed at the sending end per ampere in the short-circuited receiver. It is the transfer impedance used in network theory. It is also equal to the voltage impressed at the receiving end per ampere in the short-circuited sending terminals.

C is the current in amperes into the sending end per volt on the open-circuited receiver. It has the dimensions of admittance.

D is the current in amperes into the sending end per ampere in the short-circuited receiver. It is a dimensionless current ratio.

Table 9 gives the $ABCD$ constants for many types of networks. Table 10 gives the transformations to P_i, T , admittance and impedance forms. Chap. 9 illustrates the use of $ABCD$ constants in a stability example.

For passive networks, as dealt with here,

$$AD - BC = 1 \quad (221)$$

This affords a valuable check on the calculations. If the single-phase network used involves phase shift, it is not strictly passive. A case in point is an ideal phase-shift transformer Fig. 48. As shown $AD - BC$ is numerically one but includes a double angle term. This single-phase representation of a three phase transformer receives power at one time phase and passes it on at another time phase, although the total power flow is continuous in the three-phase transformer it represents. Usually the

†Refer to Chap. 13 for criteria of stability.

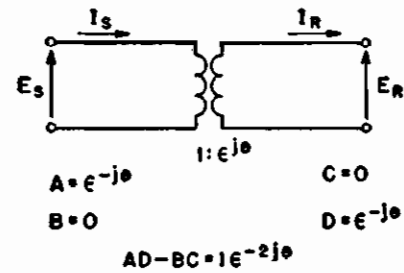

Fig. 48—Ideal phase shift transformation.

phase shift factor is removed from the equivalent single-phase circuit before calculating the $ABCD$ constants so that Eq. (221) is applicable.

Admittance Constants (or Driving Point and Transfer Admittances) are coefficients of the network current equations.

$$I_1 = Y_{11}E_1 + Y_{12}E_2 \quad (222)$$

$$I_2 = Y_{22}E_2 + Y_{12}E_1 \quad (223)$$

As indicated in Fig. 43 the positive direction is taken into the network at both ends. This permits ready extension to more than two terminals. In the following definitions current in a terminal is understood to be in the positive direction unless otherwise stated. The definitions indicate the extension to more than two terminals. In general:

Y_{11} is the current in terminal 1 per volt applied at terminal 1 with all other terminals short circuited.

Y_{12} is the current in terminal 2 per volt applied at terminal 1 with all other emfs short circuited, or vice versa. It will usually be negative for transmission-type systems with positive direction into network at both ends, etc.

The power equations as obtained from (222) and (223) are:

$$P_1 + jQ_1 = E_1 I_1 = \hat{Y}_{11} E_1 \hat{E}_1 + \hat{Y}_{12} E_1 \hat{E}_2 \quad (224)$$

$$P_2 + jQ_2 = E_2 I_2 = \hat{Y}_{12} E_2 \hat{E}_1 + \hat{Y}_{22} E_2 \hat{E}_2 \quad (225)$$

For a Three-Terminal System (as in a three-machine problem) the current equations are:

$$I_1 = Y_{11}E_1 + Y_{21}E_2 + Y_{31}E_3 \quad (226)$$

$$I_2 = Y_{12}E_1 + Y_{22}E_2 + Y_{32}E_3 \quad (227)$$

$$I_3 = Y_{13}E_1 + Y_{23}E_2 + Y_{33}E_3 \quad (228)$$

The corresponding power equations are:

$$P_1 + jQ_1 = E_1 I_1 = \hat{Y}_{11} E_1 \hat{E}_1 + \hat{Y}_{21} E_1 \hat{E}_2 + \hat{Y}_{31} E_1 \hat{E}_3 \quad (226a)$$

$$P_2 + jQ_2 = E_2 I_2 = \hat{Y}_{12} E_2 \hat{E}_1 + \hat{Y}_{22} E_2 \hat{E}_2 + \hat{Y}_{32} E_2 \hat{E}_3 \quad (227a)$$

$$P_3 + jQ_3 = E_3 I_3 = \hat{Y}_{13} E_3 \hat{E}_1 + \hat{Y}_{23} E_3 \hat{E}_2 + \hat{Y}_{33} E_3 \hat{E}_3 \quad (228a)$$

The extension to more than three terminals is apparent.

Self and Mutual Impedances are coefficients of the network voltage equations given generally in Eqs. (52)–(55). Writing these for the transmission-type network, which can in general be reduced to a number of meshes equal to the number of significant terminals:

$$E_1 = Z_{11}I_1 + Z_{21}I_2 \quad (229)$$

$$E_2 = Z_{12}I_1 + Z_{22}I_2 \quad (230)$$

Z_{11} is the voltage in terminal 1 per ampere in terminal 1, with all other "significant terminals" open circuited.
 Z_{12} is the voltage in terminal 2 per ampere in terminal 1, with all other "significant terminals" open circuited.
 Etc.

NOTE that the self and mutual impedances Z_{11} and Z_{12} as defined and used in Section 13 and in this Section 21, differ from the self and mutual drop constants defined and used in Section 20. The Z with double subscript is used in each case to conform with accepted terminology.

The power equations are obtained from (229) and (230).

$$P_1 + jQ_1 = E_1 I_1 = Z_{11} I_1 I_1 + Z_{21} I_2 I_1 \quad (231)$$

$$P_2 + jQ_2 = E_2 I_2 = Z_{12} I_1 I_2 + Z_{22} I_2 I_2 \quad (232)$$

For a three-terminal system the voltage and power equations are given below. The extension of admittance or impedance constants to any number of terminals is apparent.

$$E_1 = Z_{11} I_1 + Z_{21} I_2 + Z_{31} I_3 \quad (233)$$

$$E_2 = Z_{12} I_1 + Z_{22} I_2 + Z_{32} I_3 \quad (234)$$

$$E_3 = Z_{13} I_1 + Z_{23} I_2 + Z_{33} I_3 \quad (235)$$

$$P_1 + jQ_1 = E_1 I_1 = Z_{11} I_1 I_1 + Z_{21} I_2 I_1 + Z_{31} I_3 I_1 \quad (236)$$

$$P_2 + jQ_2 = E_2 I_2 = Z_{12} I_1 I_2 + Z_{22} I_2 I_2 + Z_{32} I_3 I_2 \quad (237)$$

$$P_3 + jQ_3 = E_3 I_3 = Z_{13} I_1 I_3 + Z_{23} I_2 I_3 + Z_{33} I_3 I_3 \quad (238)$$

IV. REAL AND REACTIVE POWER FLOW

It is well known that in a system in which impedances are largely reactive, real power flow is controlled by phase angles and reactive flow by voltage magnitudes. Ordinarily the adjustments of real power flow are made by throttle or gate adjustments (governor settings), although the flow in a closed loop can be controlled by a regulating transformer capable of introducing a phase shift. Similarly reactive flow is usually controlled by generator field adjustment (regulator setting) but in a closed loop, transformer tap adjustments can be utilized.

Quantitatively the real and reactive power over a transmission circuit or interconnection can be determined from the power circle diagrams. These diagrams give the real and reactive power at the sending and receiving ends of an interconnecting line or network, in terms of the voltages at the two ends and the angle between them. The method will be explained by examples, starting with a simple two-station system with an interconnection, and covering in all, the following conditions:

22. Examples of Real and Reactive Power Flow.

Refer to Fig. 1, or the equivalent network Fig. 49.

I. Two Stations with Interconnection (Station A to station B).

Case Ia.

- Given: 1. Sending-end and Receiving-end Voltages.
 2. Received Power.

- To Find: 1. Transmitted reactive kva.
 2. Transmitted kw and reactive kva.
 3. Required kw and reactive kva to be supplied by generators at each end.
 4. Losses (kw and reactive kva).

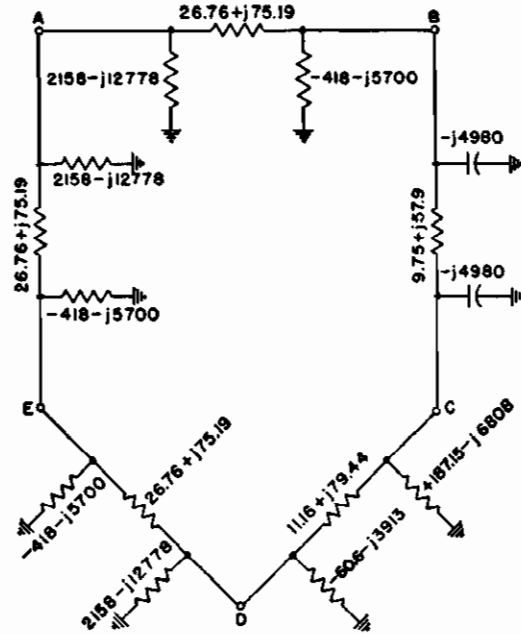

Fig. 49—Network of Fig. 2 reduced to an equivalent PI for each line.

Case Ib.

- Given: 1. Received kw and reactive kva,
 2. Receiving-end voltage.
 To Find: 1. Sending-end voltage.
 2. Sending-end kw and reactive kva.
 3. Required generation at sending end.
 4. Losses.

II. Three generating stations along one main interconnection, no closed loops, intermediate substation. A, B, C, D Fig. 1.

Case IIa.

- Given: 1. Voltages at all but D.
 2. Real power flow.
 To Find: 1. Remaining Power Quantities.
 2. Voltage at D to hold stated voltage at intermediate Substation C.

Case IIb.

- Given: 1. Voltages at all but intermediate substation C.
 2. Real power flow.
 3. Load at C, real and reactive.
 To Find: 1. Remaining power quantities.
 2. Voltage at intermediate substation C.

III. Closed Loop System.

Case IIIa. Find voltage to close under given load and power flow conditions. (To determine regulator requirements.)

Case IIIb. Find power which flows if loop is closed and flow held constant in rest of the loop.

Case I. Two-Source System—Stations A and B, Fig. 1, and the 50-mile line connecting them, will be used for illustration. The remainder of the system shown will be considered as disconnected. It may be desired to find the required voltages of the A and B buses, and the angle between them, to transmit a desired real and reactive power.

Or it may be necessary to find what real and reactive power can be transmitted for different voltages and angles. In either case the power circle diagram is an ideal method of expressing the performance of the interconnection. Two cases will be considered illustrative of the two forms in which the problem may appear.

Case Ia. Two Station System, A and B. See Fig. 49.

Fixed. Voltages and receiver real power.

Sending end	Station A
Receiving end	Station B

The given conditions are:

Sending-end voltage $\bar{E}_S = 110 \text{ kv } L-L$

Receiving-end voltage $\bar{E}_R = 110 \text{ kv } L-L$

Received power 20 Megawatts

Load at A 10 000 kw, 6200 lagging reactive kva
(10.0 + j6.2) mva

Load at B 50 000 kw, 37 500 lagging reactive kva
(50.0 + j37.5) mva

It is required to find the real and reactive power that must be generated at Stations A and B. This requires determination of the reactive power received from the line, and the real and reactive power at the input end. From the line power quantities and the local loads, the required kw and wattless generation can be determined.

General Comments

This is a characteristic problem of transmitting between buses whose voltages are fixed by load requirements. Wattless capacity in condensers or generators must be available at the proper locations because the fixed voltages determine the wattless flow over the line.

Tap-changing-under-load transformers permit maintaining the generator bus voltage while raising the effective sending-end voltage to transmit wattless. No-load taps can be used to a rather limited extent if the power flow is in one direction with not too much variation from maximum to minimum.

This problem is often further complicated by the fact that the load bus voltage must be scheduled during the day, being somewhat more under heavy load conditions.

The stability of the interconnection is not investigated in this chapter: Refer to Chap. 13 for examples of stability determinations.

Obtaining the Circle Diagram

The method of obtaining the impedance diagram, Fig. 2, from the single-line diagram, Fig. 1 has already been described in Sec. 3 and 4. To obtain the circle diagram from the impedance network from A to B two general methods of approach can be used. The intervening network can be reduced to an equivalent Pi and the circle diagram determined therefrom as shown in Table 12. Or ABCD constants can be written for the sections of the interconnection, from Table 9. These can then be combined to obtain ABCD constants for the complete interconnection as shown also in Table 9. The circle diagram data can then be determined from the overall ABCD constants, using the formulas of Tables 12 or 12a. Some prefer the ABCD constants because the method is systematic, and has a check for each step. Others prefer the equivalent cir-

cuit method because they can more clearly visualize the problem by this method. As a result both methods are used and some examples of both methods will be given. The stability problem of Chap. 13 is treated exclusively by the method of ABCD constants. This power flow problem has been treated by the equivalent circuit method.

Reducing the Network

The first step is the reduction of the network between A and B, Fig. 2, to an equivalent Pi, shown in Fig. 49. As the equivalent circuits between other buses will be needed in subsequent cases, they also must be obtained. A typical reduction follows for the section from A to B, the steps being shown in Fig. 50.

Convert the T network a, b, and c to an equivalent Pi using Eqs. (105)-(107).

$$Z_a = 2.82 + j32.3$$

$$Z_b = 24.05 + j43.05$$

$$Z_c = -j8000$$

$$Z_{s'} = Z_{ac} = Z_a + Z_c + Z_a Z_c / Z_b$$

$$= 2158 - j12 778$$

$$M = Z_{bc} = Z_b + Z_c + Z_b Z_c / Z_a$$

$$= -4940 - j19 050$$

$$Z = Z_{ab} = Z_a + Z_b + Z_a Z_b / Z_c$$

$$= 26.76 + j75.19$$

Parallel M and N to obtain $Z_{R'}$

$$Z_{R'} = \frac{MN}{M+N} = -418 - j5700$$

Plotting the Circle Diagram

From the constants $Z_{s'}$, Z , $Z_{R'}$ of the equivalent Pi, the data for plotting the power circle diagrams for line AB can be obtained, using Eqs. (206a) and (207a) of Table 12. In the following calculations E_S and E_R are expressed in kv, line-to-line which gives the power, calculated as E^2/Z , in the dimensions of megavolt amperes; that is, megawatts (mw) and reactive megavolt-amperes (reactive mva). With the power* calculated as $P + jQ = EI$, the ASA standard, a positive value of Q indicates lagging reactive power in the chosen reference direction for I.

Sending-end Circle—from equivalent Pi in impedance form

$$\bar{E}_S = 110 \text{ kv}, \quad \bar{E}_R = 110 \text{ kv}$$

Center

$$C_s = \left(\frac{1}{Z} + \frac{1}{Z_{s'}} \right) \bar{E}_S^2$$

$$= 50.9930 + j141.9209$$

Radius vector for $\theta = 0$

$$R_{s0} = -\frac{\bar{E}_R \bar{E}_S}{Z}$$

$$= -50.8369 - j142.8429$$

Power for $\theta = 0$

$$W_{s0} = C_s + R_{s0}$$

$$= 0.1561 - j0.9220$$

The sending circle has been drawn in Fig. 51 by plotting the center, the power for $\theta = 0$, and drawing the circle

*The term power is used generally meaning real and reactive power.

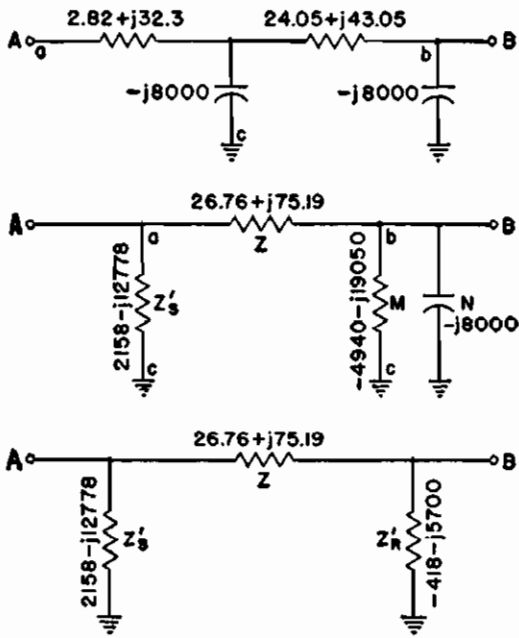

Fig. 50—Steps in the reduction of line AB to an equivalent Pi.

through the latter point. The sending power for any angle, of E_S in advance of E_R , is a point on the circle, an angle θ counter-clockwise from the radius for $\theta=0$.

Receiving-end Circle—from equivalent Pi in impedance form.

$$\bar{E}_S = 110 \text{ kv}, \quad \bar{E}_R = 110 \text{ kv}$$

Center

$$C_R = -\left(\frac{1}{Z} + \frac{1}{Z'_R}\right)\bar{E}_R^2$$

$$= -50.6821 - j140.7363$$

Radius for $\theta=0$

$$R_{RO} = \frac{\bar{E}_R \bar{E}_S}{Z}$$

$$= 50.8369 + j142.8429$$

Power for $\theta=0$

$$W_{RO} = C_R + R_{RO}$$

$$= 0.1548 + j2.1066$$

The receiving circle is located in a similar manner to the sending circle. The receiving power for any angle θ , of E_S in advance of E_R , is a point on the circle an angle θ clockwise from the radius for $\theta=0$. The corresponding sending and receiving power for a given transmission condition over the line, are points on the two circles for the same angle θ .

Interpreting the Circle Diagram For the Particular Problem—Case Ia.

From the conditions of the problem, the received power is 20 mw which is found at point 1_r on the receiving circle, Fig. 51. Laying off the same angle θ_1 on the sending circle, the point 1_s is located giving the corresponding real and reactive power at the sending-end.

$$P_{SA} + jQ_{SA} = 21.0 - j7.0 \text{ mva}$$

$$P_{RB} + jQ_{RB} = 20.0 - j7.0 \text{ mva}$$

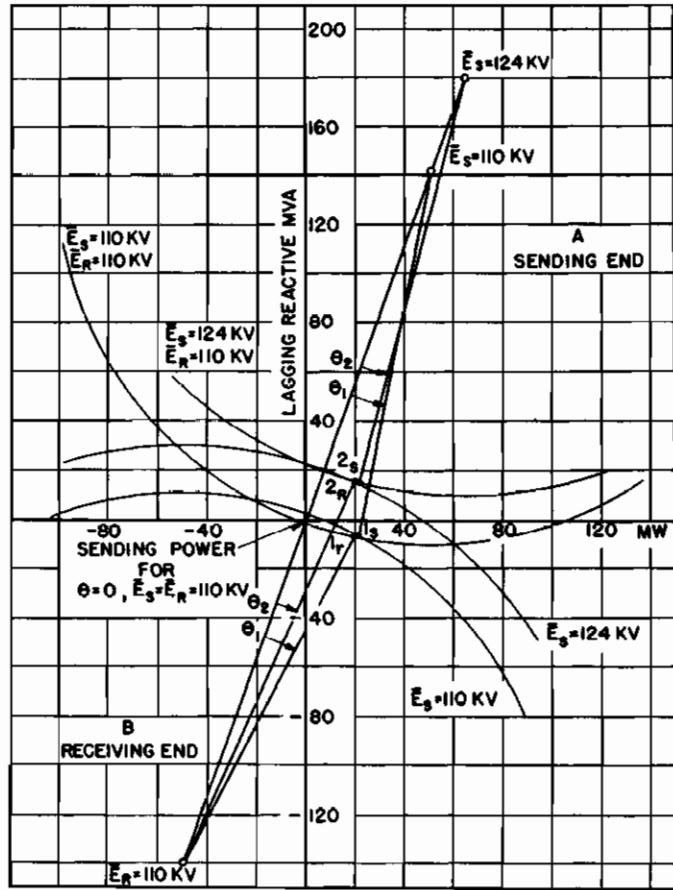

Fig. 51—Power circle diagram for line AB.

The local loads at A and B are respectively: (See Fig. 1)

$$P_{LA} + jQ_{LA} = 10 + j6.2 \text{ mva}$$

$$P_{LB} + jQ_{LB} = 50 + j37.5 \text{ mva}$$

The required generation at A is therefore:

$$P_{GA} + jQ_{GA} = P_{LA} + jQ_{LA} + P_{SA} + jQ_{SA}$$

$$= 31 - j0.8 \text{ mva}$$

or 31 mw and 0.8 lagging reactive mva. i.e., underexcited.

The required generation at B is

$$P_{GB} + jQ_{GB} = P_{LB} + jQ_{LB} - (P_{RB} + jQ_{RB})$$

$$= 30 + j44.5 \text{ mva}$$

or 30 mw and 44.5 lagging reactive mva.

The line losses are:

$$P_L + jQ_L = P_S + jQ_S - (P_R + jQ_R)$$

$$= 1 + j0 \text{ mva}$$

or 1 mw and no reactive mva.

The $I^2 X_L$ lagging reactive power consumed by the line is balanced by the E^2/X_C leading reactive power consumed by its shunt capacity.

For accurate values of losses, $P_R + jQ_R$ and $P_S + jQ_S$ can be calculated for the angle θ involved. Transformer iron losses must also be added.

From this example it can be seen that if a particular kilowatt load is transmitted over a line with fixed terminal voltages, the input and output reactive power quantities

are determined by the line, and must be provided for in the machines at each end.

Case Ib, Two-Station System, A and B, Fig. 1. Fixed receiver voltage and real and reactive power.

Sending end Station A
Receiving end Station B

The given conditions are:

Receiving-end voltage $\bar{E}_R = 110$ kv, $L-L$

Received power $(20+j15)$ mva, or 20 mw, 15 lagging reactive mva.

Load at A $(10+j6.2)$ mva.

Load at B $(50+j37.5)$ mva.

To be determined:

Sending-end voltage.

Sending-end real and reactive power.

Line Losses

Generation required at sending end. (The generation at B must obviously be $30+j22.5$ mva.)

Receiving-End Circle (Refer to Fig. 51)

The center of the receiver circle is the same as determined in Case Ia since the receiver voltage is again, 110 kv. The received power, $(20+j15)$ mva is plotted as point 2_R on the diagram. The receiver circle passes through point 2_R . Scaling or calculating the radius to this point it is found to be $\bar{R}_R = 171$ mva, scalar value. But the scalar value from Eq. (207a), Table 12 is $\frac{\bar{E}_R \bar{E}_S}{Z}$. Whence solving for the sending voltage

$$\bar{E}_S = \frac{\bar{R}_R \bar{Z}}{\bar{E}_R} = \frac{171 \times 79.8}{110} = 124 \text{ kv}$$

Sending-End Circle.

$$\bar{E}_S = 124 \text{ kv}, \quad \bar{E}_R = 110 \text{ kv}$$

Center, C_S

The vector to the center for 110 kv has previously been drawn. Increase it in the ratio $(124/110)^2$ to obtain the new center for 124 kv.

Radius Vector for $\theta=0$, R_{SO}

The radius vector for $\theta=0$, for $\bar{E}_R = 110$ kv, and $\bar{E}_S = 110$ kv has previously been obtained. Increase it in the ratio $(110 \times 124)/(110 \times 110)$ to obtain the new radius vector at $\theta=0$ for $\bar{E}_S = 124$ kv, $\bar{E}_R = 110$ kv.

Power for $\theta=0$

$$W_{SO} = C_S + R_{SO} = 7.4916 + j19.3214$$

From the center and power at $\theta=0$ the new sending power circle can be drawn. The received power point 2_R occurs at the angle θ_2 . Laying off θ_2 along the sending circle the sending power point 2_S is located. Thus:

$$P_{SA} + jQ_{SA} = 21.5 + j15.5 \text{ mva}$$

And since the load at A is

$$P_{LA} + jQ_{LA} = 10 + j6.2 \text{ mva}$$

The required generation is:

$$P_{GA} + jQ_{GA} = P_{SA} + jQ_{SA} + P_{LA} + jQ_{LA} \\ = 31.5 + j21.7 \text{ mva}$$

or 31.5 mw and 21.7 lagging reactive mva

The losses are:

$$P_1 + jQ_1 = P_{SA} + jQ_{SA} - (P_{RB} + jQ_{RB}) \\ = 1.5 + j0.5$$

or 1.5 mw and 0.5 lagging reactive mva.

The required sending-end voltage of 124 kv could be provided by a step up transformer at A having a rated high voltage of 115 kv and equipped with ± 10 percent tap-changing-under-load equipment, giving it a range of from 126.5 kv down to 104.5 kv. This would provide for transmitting only a reduced load in the reverse direction unless the transformer at B were similarly equipped.

This problem illustrates that to transmit a desired amount of wattless as well as real power over a line with fixed receiver voltage, the sending voltage must be under control of the operator or automatic means, since the required value depends on the wattless to be transmitted.

Case II. Three Generating Stations Along One Main Interconnection, and Intermediate Substation—

The methods used in analyzing a two-station system can be easily extended to a multi-station system in which the stations are all connected along one main transmission channel. Such a system is illustrated for example by Fig. 1 and Fig. 49 with line AED omitted. Because in this case power can flow over only one path, any two stations and the line connecting them can be treated as a two-station system, independent of the other stations and lines. For instance, the system of Fig. 1 with line AED omitted merely adds more stations and lines to the two-station system of Example I, and part AB can be solved as before.

Besides the addition of another generating station, the new system has the added complication of a substation between stations B and D. Since there are no generators at C to maintain the voltage, the voltage on the substation bus is determined by the voltages at the adjacent stations and by the real and reactive kva load on the substation bus.

There are in general two problems concerning the voltage at an intermediate substation such as C. First, the voltage at one of the adjacent stations may be fixed, and it is desired to maintain a given voltage at the substation by varying the voltage at the other generating station. The problem is then to find the generating-station voltage and determine the power and kva flow in both lines. This problem can be solved by setting up a circle diagram for the line from the substation to the fixed-voltage station and determining the kva flow. This kva is subtracted from the load on the substation to give the kva that must be furnished by the other line. Using this kva, the circle diagram for the other line can be set up and the desired generating bus voltage can be found as in the case Ib just preceding.

Second, the voltage at both generating stations may be fixed, together with the real power flow over each line section, and the voltage at the substation must be determined. This can be done by a cut-and-try process, using the circle diagrams of the two lines and varying the substation voltage until the sum of the reactive kva's transmitted to the substation is equal to that required by the substation load.

Each of these two operating conditions will be illustrated in the following example.

Case IIa. Multistation System with Intermediate Substation—No Closed Loops—Fixed Substation Voltage

	Sending End	Receiving End
Line AB	A	B
Line BC	B	C
Line DC	D	C

The given conditions are as follows, line AB being assumed to operate under the same conditions as case Ib.

- At A Generated = 31.5 + j21.7 mva
- Load = 10 + j6.2 mva
- Transmitted = 21.5 + j15.5 mva
- Voltage = 124 kv.
- At B Load = 50 + j37.5 mva
- Received over AB = 20 + j15 mva
- Transmitted over BC = 6.0 + j? mva
- Generated = 36 + j? mva
- Voltage = 110 kv
- At C Load = 18.3 + j7.0 mva
- Voltage = 108 kv
- At D Load = 10.0 + j7.0 mva

To be determined:

- At B Transmitted reactive over BC
- Generated Reactive
- At C Received P + jQ over BC
- Received P + jQ over DC
- At D Voltage
- Transmitted P + jQ
- Generated P + jQ

Solution:

Line BC, sending circle (B) for $\bar{E}_s = 110$ kv, $\bar{E}_R = 108$ kv
Center (Refer to Fig. 52)

$$C_s = \left(\frac{1}{Z} + \frac{1}{Z_s'} \right) \bar{E}_s^2 = 34.2200 + j200.7886$$

Radius vector for $\theta = 0$

$$R_{s0} = -\frac{\bar{E}_R \bar{E}_s}{Z} = -33.5978 - j199.5234$$

Power for $\theta = 0$

$$W_{s0} = C_s + R_{s0} = 0.6222 + j1.2652 \text{ (Point 5, Fig. 52)}$$

Line BC, Receiving Circle (C) for $\bar{E}_s = 110$ kv $\bar{E}_R = 108$ kv
Center

$$C_R = -\left(\frac{1}{Z} + \frac{1}{Z_R'} \right) \bar{E}_R^2 = -32.9870 - j193.5536$$

Radius for $\theta = 0$

$$R_{R0} = \frac{\bar{E}_R \bar{E}_s}{Z} = 33.5978 + j199.5234 = 202.3324$$

Power for $\theta = 0$

$$W_{R0} = C_R + R_{R0} = 0.6108 + j5.9698$$

Line BC circles are plotted in Fig. 52 from these data; the section near the origin being enlarged. From the sending circle the transmitted power of 6 mw is accompanied by transmitted lagging reactive power of 0.6 mva (Point 2, Fig. 52). From the receiving circle, for the same angle θ_1 , the received power at C is found to be 6.0 + j5.0 mva, as closely as the chart can be read (Point 1, Fig. 52).

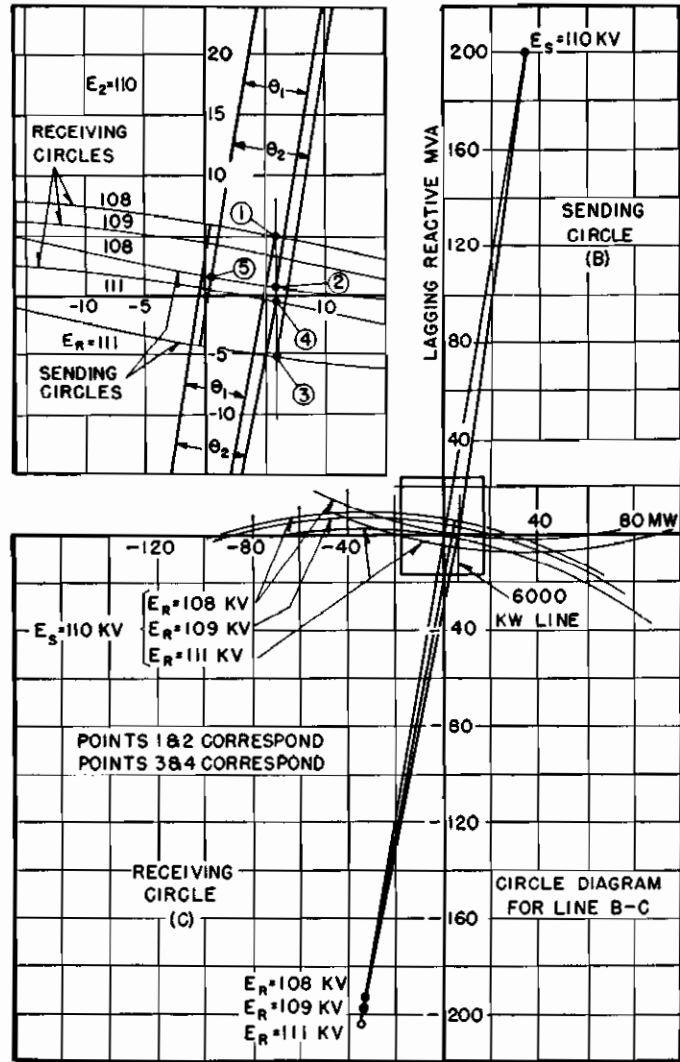

Fig. 52—Power circle diagram for line BC.

Line DC, Receiving Circle (C) for $\bar{E}_R = 108$ kv, $\bar{E}_s = ?$
Refer to Fig. 53.

$$\text{Center } C_R = -\left(\frac{1}{Z} + \frac{1}{Z_R'} \right) \bar{E}_R^2 = -20.2732 - j142.2751$$

The received power over line DC can be determined

Load at C = 18.3 + j7.0 mva

Received over BC = 6.0 + j5.0 mva

Received over DC = 12.3 + j2.0, which is plotted as point 1 of Fig. 53.

Scaling from the center to this point the radius of the receiving circle is found to be 147.9 mva, from which we can solve for \bar{E}_s .

$$\bar{R}_R = 147.9 = \frac{\bar{E}_R \bar{E}_s}{Z} = \frac{108 \bar{E}_s}{80.1}$$

$$E_s = \frac{147.9 \times 80.1}{108} = 110 \text{ kv}$$

Line DC, sending circle (D) for $\bar{E}_s = 110$ kv, $\bar{E}_R = 108$ kv
Center

$$C_s = \left(\frac{1}{Z} + \frac{1}{Z_s'} \right) \bar{E}_s^2$$

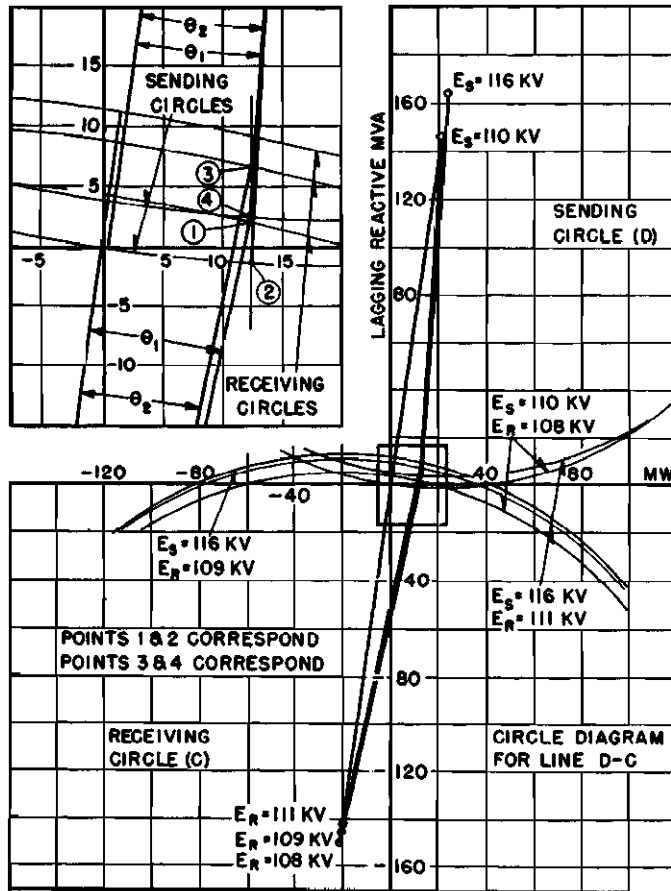

Fig. 53—Power circle diagram for line CD.

$$= 20.9354 + j146.2781 \text{ mw.}$$

Radius vector for $\theta = 0$

$$R_{s0} = -\frac{\bar{E}_R \bar{E}_S}{Z}$$

$$= -20.6011 - j146.6527 \text{ mw.}$$

Power for $\theta = 0$

$$W_{s0} = C_s + R_{s0} = 0.3343 - j0.3746 \text{ mw.}$$

The sending circle can now be plotted and laying off the angle θ_1 , the same as for the receiving circle the sending-end power is found to be $12.4 - j1.8$ mva, at point 2.

Now recapitulating,

At B Transmitted over BC	6.0 + j0.6 mva
Generation otherwise required	30.0 + j22.5 mva
Generation required	36.0 + j23.1 mva
At C Received over BC	6.0 + j5.0 mva
Received over DC	12.3 + j2.0 mva
Load at C	18.3 + j7.0 mva
Losses in line BC*	0 - j4.4 mva
or 0 mw and -4.4 lagging reactive mva, i.e., 4.4 lagging reactive mva is supplied net by the line.	
At D Transmitted over DC	= 12.4 - j1.8 mva
Load at D	= 10.0 + j7.0 mva
Generation at D	= 22.4 + j5.2 mva
Losses in line DC = 0.1 - j3.8 mva* or	
0.1 mw and -3.8 lagging reactive mva.	

*See discussion of losses in case Ia.

Case IIb. Multistation System with Intermediate Substation—No Closed Loops—Substation Voltage to Be Determined

The generating-station voltage magnitudes are assumed to be fixed. As the methods of combining loads and of determining losses are simple and have been outlined in the previous cases, this case is confined simply to determining the voltage of the intermediate substation and the reactive power flow over the lines. The real power flow is assumed.

Given:

- Voltage at B = 110 kv
- Voltage at D = 116 kv

At C

Load at C	18.3 + j7.0 mva
Received over BC	6.0 + j? mva
Received over DC	12.3 + j? mva

To be determined:

- At B Transmitted power over BC
- At C Voltage
- Received reactive over each line
- At D Transmitted power over DC.

A cut-and-try method is employed, based on assuming values of voltage at C until a value is found that results in a total received reactive power equal to the reactive load at C (+j7.0 mva). Obviously after a few trials a curve of received reactive power versus voltage-at-C can be plotted and the proper voltage read from this curve. Or after two trials the increment of reactive per increment in voltage noted, so that the third trial is simply a check. Assume, to start with, a voltage of 109 kv at C. Circle centers and radii can be found by ratioing from values calculated in Case IIa.** Refer to Table 13.

The second trial gives a sufficiently close value of total reactive (+j6.2 mva compared with the desired +j7.0 mva) and the circles corresponding to this trial are used to determine the power quantities. Thus, drawing the corresponding sending circles, and using points 3 and 4 on Fig. 52 and 3 and 4 on Fig. 53.

At B Transmitted over BC	6 - j5.2
At C Voltage is	111 kv
Received over BC	6 - j0.5
Received over DC	12.3 + j6.7
Load Assumed	18.3 + j7.0
At D Transmitted over DC	12.3 + j2.5

**Obtaining Circle Centers and Radii by Ratioing—General: In working graphically, after one sending and receiving circle have been drawn for a given intervening network, all further work can be done by simple scalar ratios and graphical construction using the following relationships.

- a. The center of a receiving circle is always along the same line through the origin, the distance to the origin being proportional to E_R^2 .
- b. The center of a sending circle is always along the same line through the origin (not necessarily the same as in a) the distance to the origin being proportional to E_S^2 .
- c. The scalar value of the radius is proportional to $\bar{E}_S \bar{E}_R$.
- d. The radius for $\theta = 0$ is always parallel to the first one drawn.

TABLE 13

	Case IIa	Case IIb, Trial 1	Case IIb, Trial 2
BC Receiving Circle, (C)			
1 $\bar{E}_S =$	110	110	110
2 $\bar{E}_R =$	108	109	111
3 Center, $C_R = -\left(\frac{1}{Z} + \frac{1}{Z'}\right) \bar{E}_R^2 =$	- 32.99 - j193.55	- 33.60 - j197.15	- 34.85 - j204.45
4 Radius for $\theta = 0$, $R_{R0} = \frac{\bar{E}_R \bar{E}_S}{Z} =$	33.60 + j199.52	33.91 + j201.37	34.53 + j205.06
5 Power for $\theta = 0$, $W_{R0} = C_R + R_{R0} =$	0.31 + j 4.22	- 0.32 + j0.61
6 Reactive corres. to 6 mw, from circle	+j 3.2	-j 0.5
DC Receiving Circle, (C)			
7 $\bar{E}_S =$	110	116	116
8 $\bar{E}_R =$	108	109	111
9 Center, $C_R = -\left(\frac{1}{Z} + \frac{1}{Z'}\right) \bar{E}_R^2 =$	- 20.27 - j142.27	- 20.65 - j144.92	- 21.42 - j150.28
10 Radius for $\theta = 0$, $R_{R0} = \frac{\bar{E}_R \bar{E}_S}{Z} =$	20.60 + j146.65	21.93 + j156.08	22.33 + j158.95
11 Power for $\theta = 0$, $W_{R0} = C_R + R_{R0} =$	1.34 + j 11.16	0.98 + j 8.67
12 Reactive corres. to 12.3 mw, from circle	+j 9.3	+j 6.7
13 Reactive received at C, Sum of 6 and 12	+j 12.5	+j 6.2

Case III. Loop System, Three Generating Stations, Two Intermediate Substations, Fig. 1*—Power flow in the complete loop system of Fig. 1* is next considered. A method for calculating the effect of a regulator for controlling phase angle and voltage ratio is given. This method in general consists of breaking the system at one point and treating it as several stations along one line up to the point of closing. The voltage required to close the loop can then be determined and also the circulating current that flows if the loop is closed without this voltage.

The simpler problem is to calculate the voltage required to close the loop for a given power flow condition, as this is simply an extension of Case II, above. The voltage required to close the loop gives the necessary setting of a regulating device to produce the assumed power flow.

It must be remembered that up to the point of closing the loop there is complete and independent control of real and reactive power flow over each line section connecting two generating stations. This assumes that permissible voltage or stability limits are not exceeded. For example, the generator voltages and throttles at A and B can be set to produce a desired real and reactive power over this line. Then holding the voltage and speed at B fixed, so as not to affect the flow over line AB, the generator voltage and throttle at D can be adjusted to give the desired flow in the BD section. Now if the voltages and speeds are held fixed at A, B, and D by suitable adjustments at those points, then the connection of a line from D to E and the passage of any amount of power over it under the control of a regulator in the line will have no effect on that part of the loop external to line AD.

Thus the problem reduces to a consideration of the flow in the section A to D only when the magnitudes and phase positions of the voltages at those two points have been previously fixed by the required conditions elsewhere in the loop.

*Fig. 49 also shows the system except for loads.

Case IIIa. Loop System, Given Power Flow, Find Voltage Across Open Point

Given Conditions.

For the system external to line AD we shall use the voltages and power flow conditions described in Fig. 54 which have been arrived at:

- For line AB from case Ia, Circle Fig. 51.
- For line BD from case IIb, Circle Figs 52 and 53.
- Load at E = 10.0 + j5.0.

Voltage at E will be taken as 111 kv for converting loads to impedances.

Required to Find.

- The voltage between A and A'.
- There are a number of ways to go about this problem.

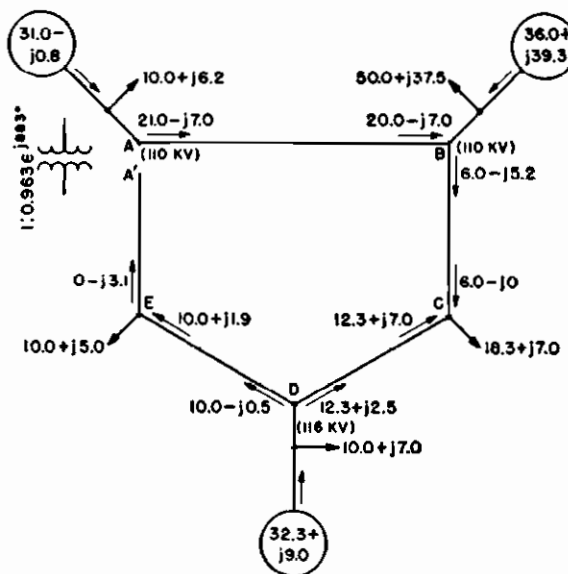

Fig. 54—Power flow condition for Case IIIa.

The one selected involves the following steps:

- a. Assume a voltage at E and determine the power consumed by the open line. Add this to the load at E to obtain the total load received over line DE .
- b. Find the voltage at E at which this load can be received.
- c. Determine the voltage at A' , and the angle between it and the voltage at A .

Proceeding with the calculations in this sequence:

- a. The input power at E to the open-ended line EA' is obtained from the impedances, Fig. 49.

$$P_s + jQ_s = \frac{\bar{E}_s^2}{\hat{Z}_s'} + \frac{\bar{E}_s^2}{\hat{Z} + \hat{Z}_R'}$$

$$= \frac{111^2}{-418 + j5700} + \frac{111^2}{2158 + j12700}$$

$$= 0.0049 - j3.0877 \text{ mva}$$

Load at E = $10.0 + j5.0$ mva
 Open line EA' = $0.0 - j3.1$ mva
 Power received from DE = $10.0 + j1.9$ mva

- b. The circle diagram for line DE is given in Fig. 55. By trial it is found that with a receiver voltage at E of 113.5 kv the received power is $10.0 + j1.9$ mva as desired and the corresponding sending power at D is $10.0 - j0.5$, within the accuracy of the graphical construction.

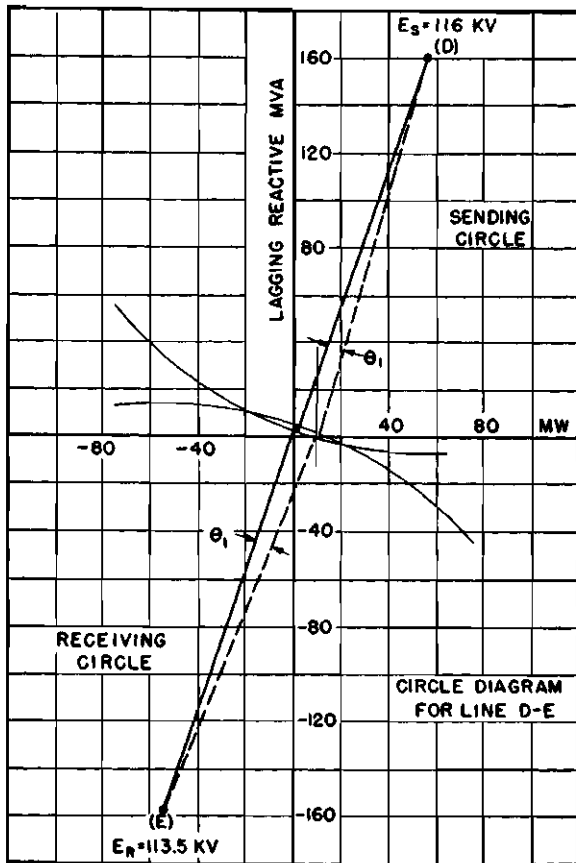

Fig. 55—Power circle diagram for line DE.

- c. The voltage at A' is:

$$E_{A'} = E_E \frac{Z_s'}{Z + Z_s'}$$

$$= \frac{113.5(2158 - j12778)}{26.76 + j75.19 + 2158 - j12778}$$

$$= 114.18 - j0.407 = 114.2 \text{ kv.}$$

Taking $E_A = 110 \epsilon^{j0}$

Angle of A in advance of B , Case Ia, $= \theta_{AB} = 8.15^\circ$
 Angle of B in advance of C , Case IIb, $= \theta_{BC} = 1.76^\circ$
 Angle of D in advance of C , Case IIb, $= \theta_{DC} = 4.14^\circ$
 Angle of D in advance of E , Case IIIa, $= \theta_{DE} = 3.23^\circ$
 Angle of A' in advance of E , Case IIIa, $= \theta_{A'E} = 0.17^\circ$
 Angle of A in advance of A' = $\theta_{A'A}$
 $\theta_{A'A} = \theta_{AB} + \theta_{BC} - \theta_{DC} + \theta_{DE} - \theta_{A'E} = 8.83^\circ$
 Thus, since $E_A = 110$ kv and $E_{A'} = 114.2$ kv

$$E_A = \left(\frac{110}{114.2} \epsilon^{j\theta_{A'A}} \right) E_{A'}$$

and a regulator having a setting such as to result in a vector ratio of

$$1.0.963 \epsilon^{j8.83^\circ}$$

closes the loop with the power flow as indicated. For any other desired power flow in the various sections of the loop the requisite regulator setting can be similarly calculated. Thus by taking the extreme conditions of flow one way and then the other, the range required of the regulator can be determined.

Case IIIb. Loop Closed Without Regulator

Given Conditions.

The load E , for simplicity is converted to an impedance on 111 kv base.
 Voltage at $A = 110$ kv
 Voltage at $D = 116$ kv
 Angle of D in advance of $A = -5.77^\circ$

To Be Determined.

Power flow in Line AD .

With the conditions stated as above the problem is easily solved by determining the circle diagram for the complete line AD . The load impedance at E is shown on Fig. 56 together with the reduction to an equivalent Pi.

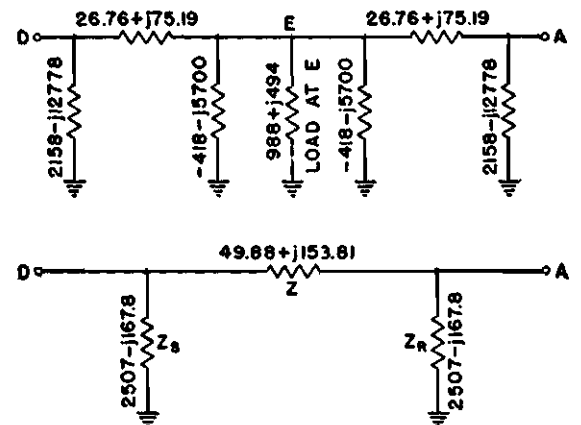

Fig. 56—Reduction of line AD.

diagram for the line DA is given in Fig. 47. Using the given voltages and angle it is found that

Power transmitted at D over $DA = -1.0 + j6.5$

Power received at A over $DA = -11 + j6.2$

From the circle diagram of a line connecting two points of known voltage and phase angle the effect of a regulator at one end can be determined by multiplying the voltage at that end by the vector ratio of the regulator and using the value thus obtained as the voltage at that end of the line.

It is hoped, that while it has not been possible to cover all conditions, a study of the methods used in the cases given will point the way to the solution of most other cases.

REFERENCES

1. "Network Theorems," *Electrical Engineers Handbook*, by Harold Pender and Knox McIlwain, Vol. V., Communication and Electronics, Section 3, Art. 6, pp. 3-11.
2. "Thevenin's Theorem," by E. L. Harder, *Electric Journal*, Vol. 35, No. 10, p. 397, October 1938.
3. "Power Supply for Main Line Railway Electrification," by E. L. Harder and P. A. McGee, *Transactions AIEE*, Vol. 52, No. 2, p. 364.
4. "Analytical Solution of Networks," by R. D. Evans, *Electric Journal*, Vol. 20, No. 4, p. 149, April 1924, and No. 5, p. 107, May 1924.
5. *Symmetrical Components*, by C. F. Wagner and R. D. Evans (a book), McGraw-Hill Book Company, Inc., New York, 1933.
6. "Circuit Diagram for Transmission Line," by R. D. Evans and H. K. Sels, *The Electric Journal* Dec. 1921, pp. 530-536 and Feb. 1922, pp. 53 and 59.

CHAPTER 11

RELAY AND CIRCUIT-BREAKER APPLICATION

Original Authors:

E. L. Harder and J. C. Cunningham

Revised by:

E. L. Harder and J. C. Cunningham

THE function of relays and circuit breakers in the operation of a power system is to prevent or limit damage during faults or overloads, and to minimize their effect on the remainder of the system. This is accomplished by dividing the system into protective zones separated by circuit breakers, such as are shown in Fig. 1. During a fault, the zone which includes the faulted apparatus is de-energized and disconnected from the system. In addition to its protective function, a circuit breaker is also used for circuit switching under normal conditions.

The relay application problem consists of selecting a relay scheme which will recognize the existence of a fault within a given protective zone, and initiate circuit-breaker operation. This problem is considered from a system point of view. The operating characteristics of protective schemes for generators, transformers, lines, and buses are discussed in their relation to overall system performance. Reference is made to other publications, particularly *Silent Sentinels*¹, for the operating characteristics and connections of individual relays. It is proposed here only to give the general features which will determine the type of scheme to be used.

The circuit-breaker application problem consists primarily of determining the interrupting requirements,

normal current, voltage, and other rating factors required to select the proper breaker for each location. These factors are discussed, and methods of calculating the fault current and interrupting rating are given.

I. GENERAL PHILOSOPHY AND BASIC RELAY ELEMENTS

As mentioned the system is divided into protective zones as shown in Figure 1, each having its protective relays for determining the existence of a fault in that zone and having circuit breakers for disconnecting that zone from the system. It is desirable to restrict the amount of system disconnected by a given fault; as for example to a single transformer, line section, machine, or bus section. However, economic considerations frequently limit the number of circuit breakers to those required for normal operation and some compromises result in the relay protection.

The relays operate usually from currents and voltages derived from current and potential transformers or potential devices. A station battery usually provides the circuit breaker trip current. Successful clearing depends on the condition of the battery, the continuity of the wiring and trip coil, and the proper mechanical and electrical

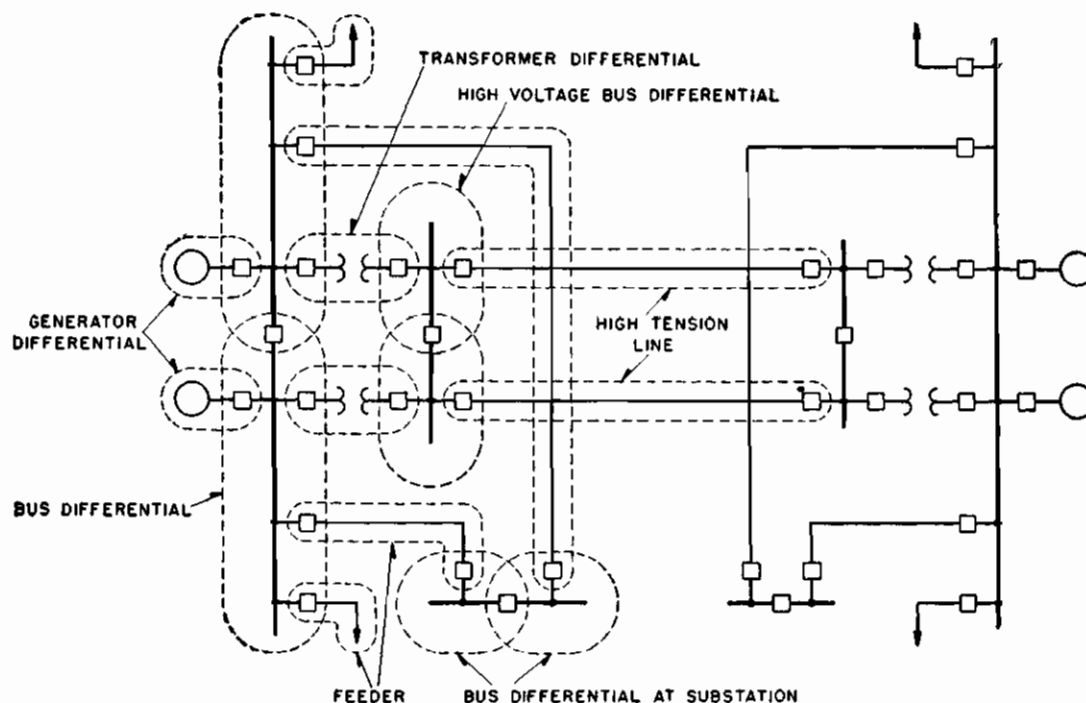

Fig. 1—Typical system showing protective zones.

operation of the circuit breaker as well as the closing of the relay trip contacts.

In event of failure of one of these elements, so that the fault in a given zone is not cleared by the first line of defense, relays and circuit breakers, some form of back-up protection is ordinarily provided to do the next best thing. This means, first of all, to clear the fault automatically, if at all possible, even though this requires disconnection of a considerable portion of the system. Once cleared, the system can generally be rather quickly restored; whereas if the fault hangs on, the line may be burned down, or apparatus damaged beyond repair, or the entire system may be shut down for an extended period. The measures taken to provide back-up protection vary widely depending on the value and importance of the installation and the consequence of failure. These will be discussed in a separate section.

Some utilities in measuring the performance of transmission line relay protection analyze all relay trip operations as shown in Table 1. The numbers shown are typical of a system operating 3000 miles of 110-kv line.

This is only an analysis of faults for which the relay tripped or should have tripped. For each of these there were several cases where the relays should not have tripped, and did not. Thus the total number of discriminations made by the relays is possibly five to ten times

TABLE 1—RELAY OPERATIONS

	Per Cent
Correct and desired.....	92.2
Correct but undesired.....	5.3
Wrong tripping operations.....	2.1
Failure to trip.....	0.4

as great as the trippings. The percentage failures are correspondingly less on this larger basis.

However, Table I has been presented at this point to bring out the following factors that enter into a highly successful protective relay system:

1. Good equipment, relays and instrument transformers.
2. A system design that can be protected and correct application of relays to provide the possible protection.
3. Good maintenance primarily to assure that all the accessories are operative.

The correct but undesired trippings are cases where the relays have done what should be expected from their characteristic curves and settings and the fault conditions involved. There may have been system changes since their application, or incorrect initial application, or application with foreknowledge that certain conditions would unavoidably operate the relays, but this was necessary to secure tripping in other desired cases.

It is important to bear in mind that simple standard system design plans can be better protected. Distance measuring and carrier or pilot-wire types of relaying are much less subject to disqualification by system changes than are over current types.

Wrong tripping and tripping failures, together with all causes of failure to clear faults, are found to stem largely from human errors, such as leaving the trip circuit open after test, or to open circuited trip coils, or mechanical

failure of the circuit breaker, or blown fuses in trip circuits (if used). Only a small part of the total failures occur in the protective relay itself. Thus close attention to the initial design, installation, testing, and maintenance of all of the accessory equipment, as well as of the protective relay proper, are needed to assure successful operation.

The application of protective relays properly requires evaluation of several factors, namely:

1. The requirements of the power service and desired functioning of the system during fault conditions to produce this result.
2. The currents, voltages, temperatures, pressures, or other indicators at time of fault which provide the fundamental basis of discrimination.
3. The characteristics of available or standard relay elements.
4. The schemes in which they are used.

A wide variety of characteristics are now available operating in response to the prime quantities themselves, or to various functions of these prime quantities, such as power, phase angle, power factor, current comparison, power comparison, impedance, reactance, modified reactance, current ratio, or phase-sequence component.

In each case the response may be instantaneous, meaning no intentional delay, or the operation may depend in a predetermined manner on the electrical quantities and time of duration.

2. Basic Relay Elements⁸⁷

The more commonly used relay elements and their underlying principles of operation are shown in Fig. 2. The schemes in which the elements are used are much more numerous. The more common ones will be described under the application headings, such as generators, transformers, and buses.

Instantaneous Elements—For instantaneous response to current or voltage the solenoid element, Fig. 2(a), is most common, appearing individually or as the instantaneous attachment with the induction-type overcurrent relay. The beam element, (b), with spring or weight bias is used where low burden is desirable, as when setting for low ground currents with low-ratio bushing current transformers. The polar element, (j), is of far lower burden than the nonpolar types and has come into widespread use since 1935 as the receiver relay of directional-comparison carrier equipments, and is the basic element when supplied from networks or electronic devices. For example, it appears as the operating element in a pilot wire relay, in a phase-comparison carrier relay, in linear-coupler bus protection, and in supervision of pilot wires.

Because of its higher pick-up to drop-out ratio and less accurate setting the clapper-type element, (c), is used less frequently for the primary protective functions but is widely used as an auxiliary relay.

Induction Elements—The induction-disk element, (d), continues to be most widely used, its reliability and inherent time characteristic giving it great flexibility for co-ordinating relays in series or co-ordinating with fuses or direct-trip devices. A variety of characteristics are available from the definite-minimum-time, which is ideal for securing definite time steps between relays, to the very inverse which provides faster tripping with the same margins when the fault current drops considerably from one

Fig. 2—Relay elements.

NOTES:

- (a) Operating characteristics show typical order of magnitude only; varies with type of relay and adjustments.
- (b) Subscript ₀ indicates setting or balance point value.

- (c) All current relays are also voltage relays by suitable no. of turns and external series impedance since $I = E/Z$.
- (d) "Instantaneous" is defined as "no intentional delay."

Schematic

(a)

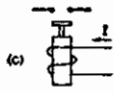

Solenoid, "Instantaneous," AC or DC, adjust by taps on coil or by initial plunger position.

Operating Characteristics^(a)

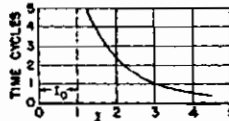

Operates for $I > I_0^{(b)}$.

(b)

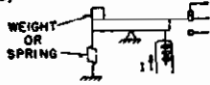

Balance beam, AC or DC, "Instantaneous," adjust by coil taps, and core screw (airgaps in magnetic circuit).

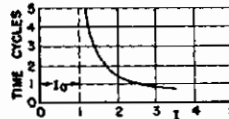

Operates for $I > I_0$.

(c)

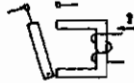

Armature or clapper type, AC or DC, "Instantaneous," usually fixed settings by design. Primarily auxiliary voltage relay.

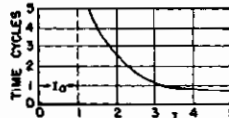

Operates for $I > I_0$.

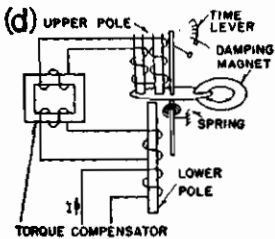

Induction disk inverse-time over-current element—AC-Current is supplied to the lower pole, and by inductive coupling to the upper pole, directly, or through a torque compensator (saturating transformer). The upper pole induces currents in the disk. Torque is produced by the reaction between these currents and flux from the lower pole. Adjust current setting by coil tap and time setting by contact travel.

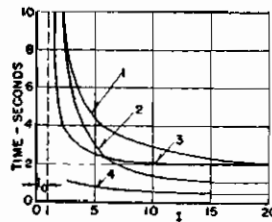

Operates for I greater than I_0 .

Times shown are maximum. Relays adjustable for times down to 0.1 or 0.05 times those shown.

- 1 Inverse, low energy
- 2 Very inverse, low energy
- 3 Standard energy definite minimum time
- 4 High-speed, no torque compensator

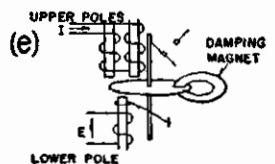

Induction disk directional element. Current induced in the disk by the upper pole reacts on flux from the lower pole to produce torque.

- 1 Lag loop to bring lower pole flux in phase with upper pole current at unity power factor of E and I .

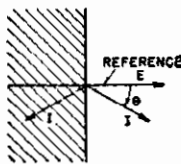

Vector diagram of E and I .

Contacts close for I in unshaded region, open in shaded region. Torque expression

$$T = K\bar{E}\bar{I} \cos \theta$$

where K is a constant, θ is the power factor angle.

Schematic

(f)

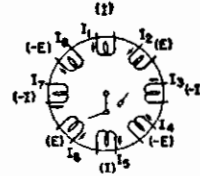

Multiple pole induction cup or disk. Each pole produces a torque product in conjunction with its adjacent poles and lesser torques in conjunction with those one pole removed, etc.

Operating Characteristics^(a)

Example: Connected as directional element (quantities in parentheses applied to respective poles) for watt characteristics, ϕ is made zero.

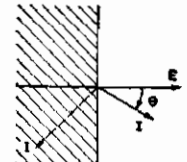

Contacts close for I in unshaded region, open in shaded region. Torque expression

$$T = K\bar{E}\bar{I} \cos \theta.$$

$$T = K_1\bar{I}_1\bar{I}_2 \cos(\theta_{12} + \phi_1) - K_1\bar{I}_1\bar{I}_3 \cos(\theta_{13} + \phi_1) + K_1\bar{I}_3\bar{I}_4 \cos(\theta_{34} + \phi_1) - K_1\bar{I}_3\bar{I}_2 \cos(\theta_{32} + \phi_1) + K_1\bar{I}_5\bar{I}_6 \cos(\theta_{56} + \phi_1) - K_1\bar{I}_5\bar{I}_4 \cos(\theta_{54} + \phi_1) + K_1\bar{I}_7\bar{I}_8 \cos(\theta_{78} + \phi_1) - K_1\bar{I}_7\bar{I}_6 \cos(\theta_{76} + \phi_1) + K_2\bar{I}_1\bar{I}_3 \cos(\theta_{13} + \phi_2) - K_2\bar{I}_1\bar{I}_7 \cos(\theta_{17} + \phi_2) \text{ etc.}$$

} First Order Terms
} Second Order Terms

(g)

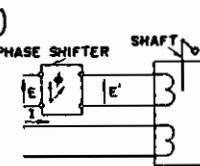

Induction disk or cup directional element as in e or f , with phase shift, ϕ , applied to voltage, \bar{E} .

ϕ is the phase shift angle.

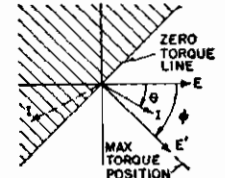

Contacts close for I in unshaded region, open in shaded region. Torque Expression

$$T = K\bar{E}\bar{I} \cos(\theta - \phi).$$

(h)

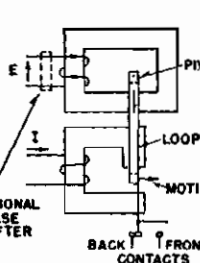

Inductor-loop high-speed directional element. Current induced in the loop by transformer action from the voltage winding reacts with flux crossing the gap of the current electromagnet to produce torque.

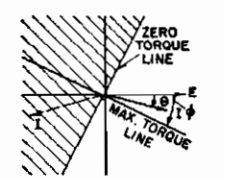

General characteristics $T = K\bar{E}\bar{I} \cos(\theta - \phi)$.

Watt characteristic adjusted for $\phi = 0$ $T = K\bar{E}\bar{I} \cos \theta$. Front contacts close for I in unshaded area. Back contacts close for I in shaded area.

Fig. 2—Relay elements—Continued

Schematic

(i)

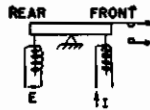

High-speed balance-beam impedance element—operates when “current pull” on front of beam overbalances “voltage pull” on rear of beam. Adjust balance point by current—coil taps and core screw (air-gap adjustment).

Operating Characteristics^(a)

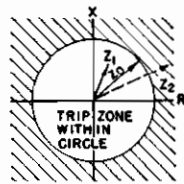

Balance point $\bar{E} = \bar{Z}_0$ (radius of circle). Examples:
 $\frac{\bar{E}}{\bar{I}} = \bar{Z}_1 < \bar{Z}_0$ trips.
 $\frac{\bar{E}}{\bar{I}} = \bar{Z}_2 > \bar{Z}_0$ does not trip.

Schematic

(m)

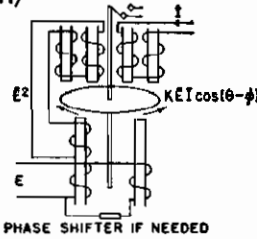

PHASE SHIFTER IF NEEDED
 Induction impedance element \bar{E}^2 pulling against $KE\bar{I} \cos(\theta - \phi)$.

Operating Characteristics^(a)

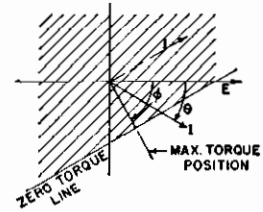

Current tripping characteristics with fixed voltage. Contacts close for I in unshaded area. Balance point at
 $\bar{I} = \frac{\bar{E}}{K \cos(\theta - \phi)}$
 or $\bar{Z} = \frac{\bar{E}}{\bar{I}} = K \cos(\theta - \phi)$.

(j)

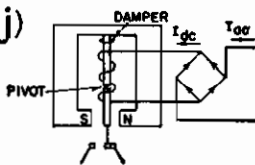

Polar element DC (or AC is used with rectifier), “instantaneous” type, current in the operating coil makes the moving armature a north pole. It is drawn toward the south pole of the permanent magnet.

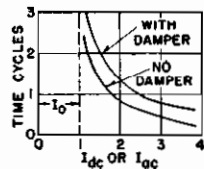

Operates for I_{d0} or I_{a0} greater than I_0 .

(Right) Contacts close for Z in unshaded area. Balance point at

$$\bar{Z} = \frac{\bar{E}}{\bar{I}} = K \cos(\theta - \phi)$$

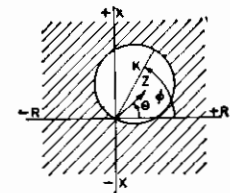

(k)

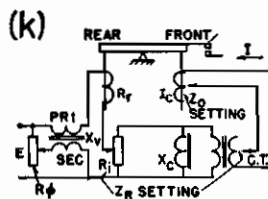

High-speed balance-beam modified impedance element. Adjust impedance radius of circle, Z_0 , by current coil taps, E , and core screw (air gap). Adjust angle of line along which center is shifted by taps on resistor, R_ϕ . Adjust impedance Z_R by which center is shifted by taps on current transformer, C.T., and on resistor R_1 .

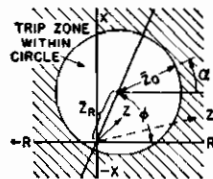

Displaced circle impedance characteristic relay trips for all faults for which impedance, Z , seen by relay falls within circle. Z_0 , Z_R , and ϕ are adjustable. Balance point locus:—
 $Z = \bar{Z}_R e^{j\phi} + \bar{Z}_0 e^{j\alpha}$
 for all values of α .

(n) RESTRAINING

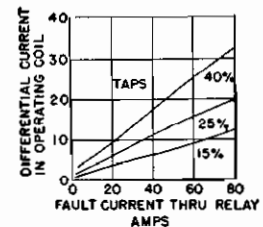
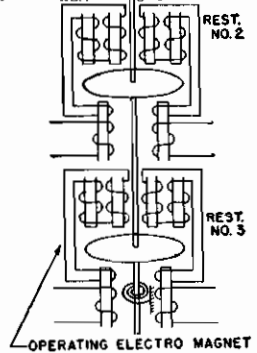

Contacts close for currents above curve corresponding to relay setting. (Left) three winding transformer differential relay. (Damping magnet not shown). Adjust by taps on operating winding. (Also see Figure 5)

(o)

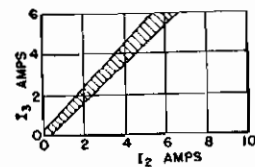
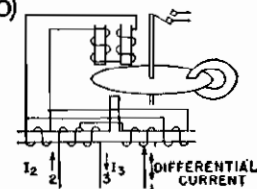

Induction-type ratio-differential relay for generator and transformer protection. Operates in 0.1 to 0.2 sec. on heavy faults. Contacts close for currents in unshaded areas. (I_2 and I_3 approx. in phase.) Scale shown is for a 10 percent differential generator relay.

(l)

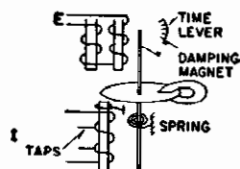

Induction type power relay. Operating torque is product of current induced in disk by upper pole and flux from lower pole.
 1. Lag loop to bring lower pole flux in phase with upper pole current at unity power factor of E and I .

TYPICAL POWER VECTOR DIAGRAM

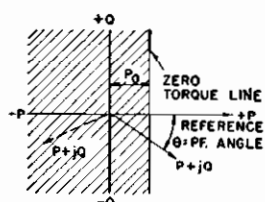

$P + jQ = E \hat{I} (P = \bar{E} \bar{I} \cos \theta)$
 Contacts close for $P + jQ$ in unshaded region with timing as indicated below.

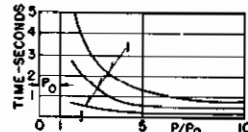

I on typical time lever settings.

(p)

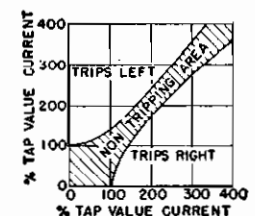
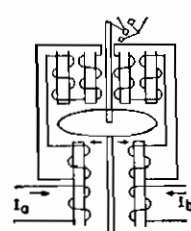

Induction type phase balance relay (contact normally spring centered). A second disk on same shaft balances I_a vs I_b .

Fig. 2—Relay elements—Continued

Schematic

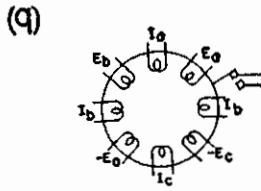

8 pole induction cup or disk connected as a polyphase directional element.

Operating Characteristics^(a)

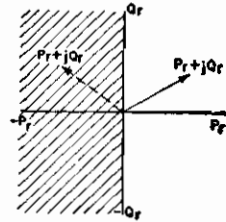

Response proportional to $K[E_1 I_1 \cos(\theta_1 - 60 + \phi) + E_2 I_2 \cos(\theta_2 + 60 + \phi)]$. For positive sequence power elements close for $P_R + jQ_R$ in unshaded region. θ_1 and θ_2 are positive and negative sequence PF angles; ϕ is relay design or adjustment angle.

Schematic

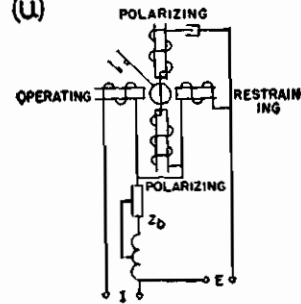

High speed 4 pole induction cylinder type MHO unit (offset when $Z_b \neq 0$). Radius and ϕ adjustments not shown.

Operating Characteristics^(a)

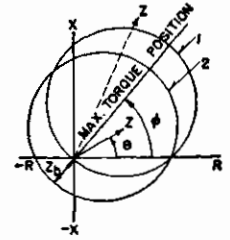

Contacts close for Z inside the circle. Balance point for circle 1 ($Z_b = 0$) $Z = \frac{K \cos(\theta - \phi)}{K}$
Balance point for circle 2 ($Z_b \neq 0$) $Z = \frac{K \cos(\theta - \phi)}{K} - Z_b$.

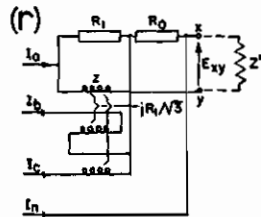

Combined pos.-seq.-current and weighted zero-seq.-current filter.

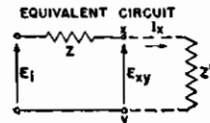

$$I_x = \frac{2R_1}{Z + Z'} (I_1 + KI_0)$$

where $K = \frac{3R_0 + R_1}{2R_1}$
The internal voltage is: $E_1 = 2R_1(I_1 + KI_0)$
The internal impedance is: $Z = R_1 + R_0 + z$
where z is the impedance of indicated wdg. of 3-wdg. reactor.

(v)

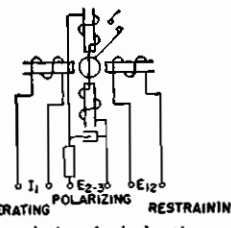

High speed 4 pole induction cylinder type directional starting unit.

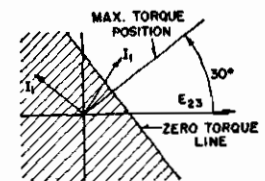

Current tripping characteristic with fixed voltage. Contacts close for I_1 in the unshaded area. Balance point for $Z = \frac{E_{12} \sin \beta}{KI_1 \cos(\alpha - 30^\circ)}$
where β is angle between E_{12} and E_{23}
 α is angle between I_1 and E_{23}

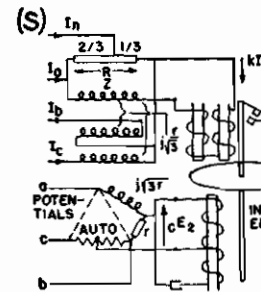

Negative sequence directional element—using potential, E_2 , and current, I_2 , sequence segregating networks.

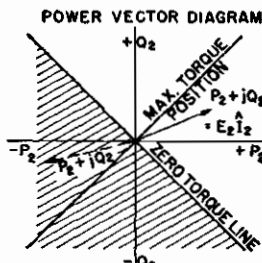

Contacts close for $P_2 + jQ_2$ in unshaded region.

(w)

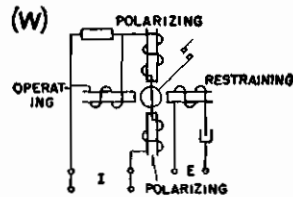

High speed 4 pole induction cylinder ohm unit (blinder).

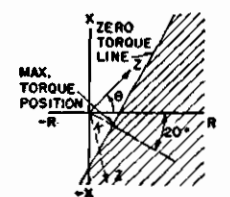

Balance point $Z \cos(\theta + 20^\circ) = K$. Contacts close for Z in the unshaded area.

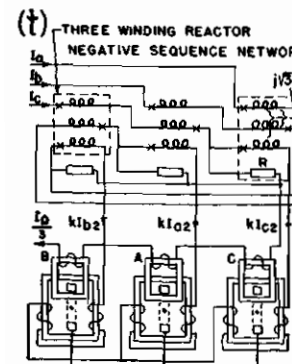

Phase selector relay (selects faulty phase for single line-to-ground fault).

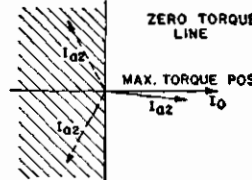

Shown for "A" element. Contacts close to right for I_{a2} in unshaded region. For fault on phase A-grd I_{a2} is in approx. position shown by full line; for a fault on B-grd or C-grd it is as shown by dotted lines. Other two phases similar.

(x)

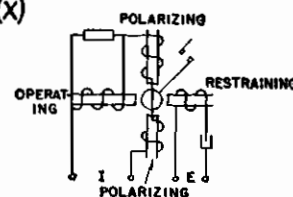

High speed 4 pole induction cylinder reactance unit.

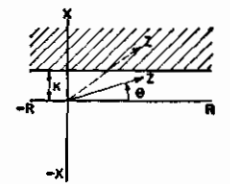

Balance point $Z \cos(\theta - 90^\circ) = K$. Contacts close for Z in unshaded area.

Fig.2—Relay elements—Continued

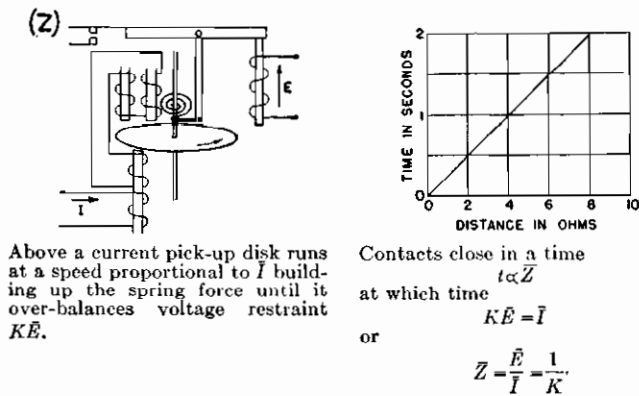
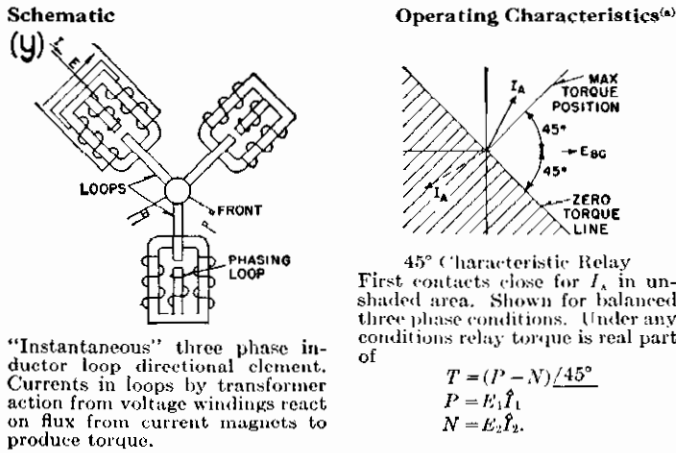

relay location to the next. The more inverse characteristic also co-ordinates better with fuses.

The induction disk serves as a directional element, (e), or, when used with a spring, as a watt element, (l), the electric torque being proportional to $EI \cos \theta$, where θ is the power-factor angle. Either of these can, of course, be current polarized instead of voltage polarized for use in ground relaying when a bank-neutral current is available.

The relative phase of voltage and current can be shifted by internal or external phase-shifting devices to produce maximum torque for power factors other than unity, as in (g). For example, the directional element for ground relaying usually has its maximum torque for current lagging the voltage by 60 or 70 degrees to provide maximum torques for the fault conditions. A pure watt characteristic is used with the 30 and 60 degrees connections for phase directional relays, the phase shift being provided by using the voltage of a different phase from the current. With the 90 degree connection this shift is too much, and the voltage is advanced about 45 degrees by a phase shifter to provide a maximum-torque position for a current 45 degrees lagging.

The disk is provided also with an electromagnet, (o), producing ratio characteristics for use as a differential relay for generators or transformers. The generator-differential relay is shown in (o). The transformer relay has

windings 1 and 2 tapped for different current-transformer ratios.

Referring to Figure 2 (o), the differential current produces lower-pole flux which acts in the operating direction on disk currents produced by the upper pole which is transformer fed from the same differential current. The restraint torque, giving the ratio-differential characteristic, is produced by the through current in coils 2-3, which supply disk current by transformer feed to the upper pole, and by lower-pole flux produced by the same through current.

The induction disk provides a tripping-time-proportional-to-impedance characteristic as shown in Figure 2(z).

Multiple Electromagnets or Disks—Two electromagnets on the disk provide for balancing mechanical torques with no phase angle effects (see (p)). When these are both current electromagnets, the relay is the regulating-transformer differential relay which balances the current in the shunt exciting winding against the through line current. For example in a ± 10 percent regulating transformer, it operates when the shunt current exceeds about 15 per cent of the through current. When both electromagnets are voltage energized, the voltage-differential relay results. When one is voltage (actually responsive KE^2) and one is a product element, $EI \cos (\theta - \phi)$, a balance occurs when $I \cos (\theta - \phi) = KE$. This impedance characteristic is shown in current and also in an $R-X$ plot in (m).

A second disk on the same shaft provides space for two more electromagnets. This structure is used as the phase-balance relay for motor protection, whose characteristics are shown in (p). It is used for the 3-winding-transformer differential relay, using one operating electromagnet and three restraint electromagnets, (n). With two current-input windings on each electromagnet and with two relays per phase the multirestraint bus differential relay results. Its used will be described later.

Multiple-Pole Cylinder or Disk Elements—The multiple-pole cylinder or disk element is illustrated in (f). The example shows how it would be energized to act as a single-phase directional element having torque proportional to $EI \cos \theta$. This element also serves as a polyphase-directional element by the connection, (g). The multiple-pole element is flexible making possible a variety of other combinations.

Four-Pole Induction-Cylinder Elements—These high-speed elements serve a variety of purposes as shown in Figure 2(u), (v), (w), and (x). The element (u), designated a mho element, operates with torque $E^2 \cos (\theta - \phi)$ restrained by torque proportional to E^2 . It produces the circular-impedance-tripping locus passing through the origin or relay location, the same as shown for the induction disk in (m). Or with either element, the circle can be shifted from this position by current compensation, IZ_b , in the restraining circuit, as indicated. A directional-starting unit, (e), is obtained using current times shifted-quadrature voltage for operating and the product of two delta voltages for restraint. This results in maximum torque for current 30 degrees ahead of the quadrature voltage or about 60 degrees lagging the unity-power-factor position.

The special impedance characteristic, (w), obtained, by

I^2 operating against $EI \cos(\theta + 20 \text{ degrees})$ is used to restrict the tripping area to assist other relays in differentiating heavy load swings from faults. A reactance element, (x), is obtained similarly with the phase-shift devices arranged so that the maximum-torque line is along the x (reactance) axis.

Inductor-Loop Element—The inductor loop, (h), provides a very high speed and very reliable directional element which has been used for many years now in high-speed distance measuring relays.

Balance-Beam Element—The basic balance-beam impedance element is shown in (i), a balance occurring for $E/I = Z_0$. For higher impedances than Z_0 (current relatively lower) the contacts remain open; whereas for lower impedances (relatively higher currents) they close quickly. Since the balance is mechanical, the phase angle between voltage and current is of minor consequence, and the tripping characteristic, plotted on an R and X diagram is substantially a circle.

Modified-Impedance Characteristic—The circular characteristic may be shifted by some circuits auxiliary to the element as shown in (k), in order to provide better discrimination between fault currents and load and swing currents on long, heavily-loaded transmission lines. The shifting imparts a directional characteristic to the relay in addition to narrowing its tripping region to more nearly just that required for faults.

Networks and Auxiliary Circuits—It may be noted that in discussing fundamental relay elements certain auxiliary circuits external to the mechanical relay have been introduced: in (g), the phase shifter; in (j), the Rectox; and in (k), a full fledged network to produce in the relay element proper, the desired currents. This is a trend of which we shall certainly see more as time goes on, as static circuits are devised to produce a simple current output proportional to the desired function of the various line currents and voltages.

Sequence-Segregating Networks, $I_1 + KI_0$ —The method of symmetrical components has been the key that has unlocked the door to a number of the aforementioned possibilities, some of which are illustrated in (r), (s), and (t). The positive- and zero-sequence network in (r) is commonly used in pilot-wire relaying, where it is desired to compare over the wires only one quantity, which is a good measure of the fault current irrespective of what kind of fault it may be, that is $A-B$, $A-Grd$, ABC . The relay can be given almost independent and widely different settings for phase faults and ground faults, using the single relay element. For example, it may be set for one ampere of ground fault to provide the requisite sensitivity, but for ten amperes of 3-phase current to avoid operation on loads.

A negative-sequence directional element is shown in (s). It is an adequate directional element for ground faults on reasonably well-grounded systems, and requires only two potential transformers rather than three as with usual residual-directional relays.

Another novel application, (t), is the phase-selector relay to determine which phase is faulted. This information is necessary in single-pole tripping and reclosing schemes. It is predicated on the knowledge, from symmetrical-components theory, that the negative-sequence current in

the faulted phase only is in phase with the zero-sequence current. Individual overcurrent elements in the three phases could not be used for this selection as all three would pick up for a single line-to-ground fault on many solidly-grounded systems.

II. PROTECTIVE SCHEMES

Protective schemes may be conveniently classified as follows:

1. Apparatus Protection
2. Bus Protection
3. Line Protection

Thus, in Fig. 1, generator and transformer protection come under the "Apparatus" classification; generator buses, high-voltage buses, and substation buses, under the second classification; and high-voltage transmission lines and feeders under "Line Protection."

The relay application chart, Table 2, has been included for ready reference in determining the operating principles and application of various specific relay types referred to throughout this chapter.

3. A-C Generators

Most a-c generators above 1000 kva and many smaller machines are equipped with differential protection arranged to trip if the currents at the two ends of each phase winding differ. This scheme is shown in Fig. 3.

Smaller machines are sometimes operated without differential protection, but if paralleled with larger machines

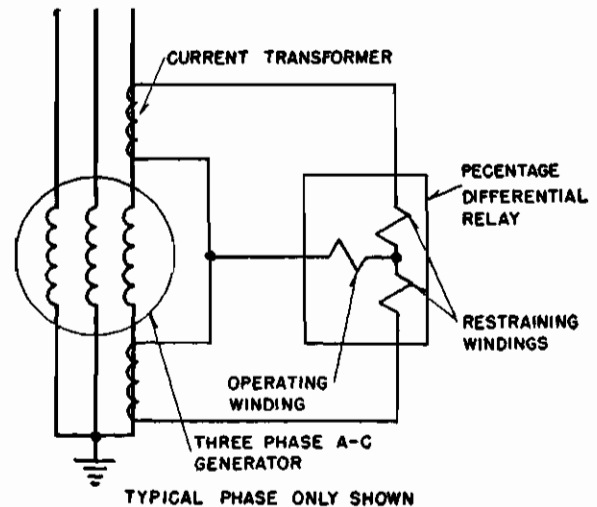

Fig. 3—Connections for one phase using the percentage differential relay for generator protection.

or with a system, they may be arranged to trip off on a reversed flow of power into the machine.

For differential protection the Type CA normal-speed, induction, ratio-type relays are used in the large majority of cases, their speed (about 0.1 second relay time on severe faults) being adequate to prevent serious burning of the iron in nearly all cases. However, a high-speed generator-differential relay, Type HA¹⁹, is available providing

1-cycle protection and is being used with 100 per cent success in a number of important applications.

The relay is usually arranged to trip the generator, field circuit, and neutral circuit breakers (if any) simultaneously by a manually-reset lockout relay in new installations. Frequently the relay also trips the throttle and admits CO₂ for fire prevention. For example it may be required to coordinate with other high speed relays or to reduce the shock to the systems.

If a single-winding generator (or equivalent) is connected to a double bus through two breakers, a current transformer matching problem is introduced. The current transformers in the connections to the busses may carry large currents from one bus to the other in addition to the generator current. Thus, matching is not assured by identical current transformers as in the simpler case of Fig. 3, and consequently, the Type HA relay is preferred for this case because of its superior discriminating qualities.

The Type CO relay is also used for generator differential protection. It provides straight differential protection, as contrasted with percentage differential, the diagram being the same as Fig. 3 without the restraining coils. Its setting must be considerably coarser than that of the CA relay because there are no restraining coils to desensitize it when high through-fault currents are flowing.

Double-Winding and Multiple-Winding Generators—The differential protection scheme of Fig. 3 does not detect turn-to-turn short circuits within the winding because the entering and leaving currents of a phase remain equal. Double and multiple winding machines provide a means for obtaining such protection in the larger, more important generators. The currents in the parallel branches, become unequal when turns are short circuited in one branch. The differential relays, Type CA or HA, can be arranged to detect shorted turns, grounds* or phase-to-phase faults, by placing one current transformer in the neutral end of one of the parallel windings, and one of double ratio at the line end in the combined circuit. The choice of schemes depends somewhat on the facility with which leads can be brought out and the necessity of overlapping the generator breaker. With hydrogen cooling additional leads can be brought out through the necessary gas-tight bushings only with considerable difficulty, and usually there is no space for transformers inside the hydrogen compartment.

Effect of the Method of Grounding—The method of grounding the generator neutral affects the protection afforded by differential relays. For example, if sufficient grounding impedance is used so that a ground fault at the generator terminals draws full load current, then for a fault at the midpoint of the winding, where the normal voltage to ground is half as great, the fault current will be approximately one-half the full load current. When a ground fault occurs 10 percent from the neutral end of the winding, the fault current, being limited largely by the neutral impedance, is about 10 percent of full load current. This corresponds to the sensitivity of a 10 percent differential relay and, therefore, represents the limit of protection for phase to ground faults with such a relay. For

*With the same limitations as for a single winding generator.

lower impedance grounding the differential relay protects closer to the neutral. With higher impedance grounding, the limit of protection for ground faults is farther from the neutral end, and for an ungrounded machine, the differential protection is ineffective against ground faults. The protection afforded for phase-to-phase, double-phase-to-ground, or three-phase faults is relatively unaffected by the method of grounding. A complete discussion of the methods of grounding is given in Chap. 19.

Solidly Grounded and Low Resistance or Reactance Grounded Machine—If the generator is solidly grounded, or grounded through a reactor or resistor, drawing at least full-load current for a ground fault at a line terminal, the usual 10 percent differential relay operates for practically any short circuit within the machine and for grounds to within 10 percent of the neutral, or closer if the ground current is higher.

Ungrounded, and Potential-Transformer-Grounded Generators—are those grounded only through the natural capacitance from the metallicly connected windings, buswork, and cables to ground. The potential transformer from neutral to ground, if properly applied†, serves as a measuring device only. To insure that this is so, it must be liberally designed so that under no condition will its exciting current become appreciable compared with the charging current to ground. Otherwise, ferro-resonance may occur. Usually a full line-to-line rated transformer will suffice. The potential transformer and a voltage relay such as the SV (instantaneous) or CV (inverse time) may be used to initiate an alarm or optionally to trip. Or, on lower voltages, a static voltage unbalance indicator may be used connected directly to the primary circuit. Such an instrument is the Type G. These devices supplement the generator differential protection to provide indication or tripping for ground faults. Light resistance grounding as covered in the next section is generally preferred to ungrounded operation.

Light-Resistance-Grounded Generators — This scheme and an associated protective arrangement is illustrated in Fig. 29 of Chap. 19. Indication from a voltage relay, connected in parallel with the resistor as shown, or from a current relay, such as the Type BG, connected in series with the resistor, may be used to sound an alarm or to trip, depending on the application. Combinations of sensitive alarm and coarser trip, or of alarm and time-delay trip, have also been used. The latter gives time to transfer the load to another machine at the hazard of operating with a fault on one phase.

This scheme was designed primarily for the unit station arrangement in which a generator and step-up transformer are operated as a unit without an intervening bus. However, it can also be used where an intervening bus carries the station service transformer and one or two short feeder cables. A limited amount of selectivity is possible by the use of a polarized relay, such as the CWP-1, which obtains most of its energy from a potential coil in parallel with the grounding resistor. Such a relay used in the station-service feed, for example, can detect a ground on that circuit.

Field Protection—While a large number of machines still operate without any protective relays to function on

†See also Light-Resistance-Grounded Generators.

TABLE 2—RELAY APPLICATION CHART

RELAY TYPE	GENERAL APPLICATION										CHARACTERISTICS: RESPONSIVE TO, OPERATES ON										TIME CHARACTERISTIC			RELAY TYPE
	Transmission Line		Bus Protection	Transformer Protection	Generator, Motor Machine Protection	Auxiliary Relay	Risk Wire Protection	Carrier Protection	Current	Voltage	Distance		Directional		Current Differential	Miscellaneous	Inverse	High Speed	Definite					
	Phase Fault	Ground Fault									Impedance	Reactance	Potential Polarized	Current Polarized										
A					○	△			○											A				
AV					○	△			○											AV				
BG			○					○												BG				
BL				○	○			○							△	○				BL				
CA (GEN)			△		○		△								○	□				CA (GEN)				
CA (TRANS)				○											○	□				CA (TRANS)				
CA-4			△	○	△										○	□				CA-4				
CA-6			○	△	△										○	□				CA-6				
CAM				○											○	○				CAM				
CF-1					○				○						①	○				CF-1				
CH	△	○					△						○			□				CH				
CHC		○					△						○			□				CHC				
CH-3	○	○					△						○			□				CH-3				
CHV-3	○	○					△		△				○			□				CHV-3				
CI						⑤			○							□				CI				
CJ						⑥			○							□				CJ				
CM	△				○			○							△	□				CM				
CO	○	○	△	△	△			○							△	○				CO				
CO (AMMETER TYPE)					○			○							○	○				CO (AMMETER TYPE)				
COH	△	△	○	△	△			○								○				COH				
COI	○	○	△	△	△			○								○				COI				
CP					○				○							○				CP				
CR	○	○						○					○			○				CR				
CRC		○						○					○			○				CRC				
CRN-1					○			○					○			○				CRN-1				
CRS		○						○					○		⑧	○				CRS				
CT				○	○										⑨	○				CT				
CV						○			○							○				CV				
CV (VOLTMETER TYPE)		○				○			○						△	○				CV (VOLTMETER TYPE)				
CW					○			○					○			⑩	○			CW				
CWC		○						○					○			○				CWC				
CWK					○			○					○			⑪	□			CWK				
CWP		○						○					○			○				CWP				
CWP-1		○						○					○			○				CWP-1				
D-3					○										⑫	○				D-3				
DT-3				○	○			⑬							⑫	○				DT-3				
H-3	○	○					△	△					○			○				H-3				
HA (GEN)					○									○						HA (GEN)				
HA (TRANS)				○										○						HA (TRANS)				
HCB	○	○					○		○					○		○				HCB				
HCR	○	○						○					○			○				HCR				
HCRC		○						○					○			○				HCRC				
HCZ	○	○								○						○				HCZ				
HD	○	○					△		○					○	⑬	○				HD				
HKB	○	○						○								○				HKB				
HO-2		○						△								○				HO-2				
HQS					○			⑭								○				HQS				
HPS					○				○							○				HPS				
HR	○	○						○					○			○				HR				
HR-1	○	○						○					○			○				HR-1				
HRC		○						○					○			○				HRC				

TABLE 2—RELAY APPLICATION CHART—Continued

RELAY TYPE	GENERAL APPLICATION										CHARACTERISTICS RESPONSIVE TO, OPERATES ON										RELAY TYPE
	Transmission Line		Bus Protection	Transformer Protection	Capacitor, Inductor, Machine Protection	Auxiliary Relay	Pilot Wire Protection	Circuit Protection	Current	Voltage	Distance		Directional		Current Differential	Miscellaneous	Inverse	High Speed	Definite		
	Phase Fault	Ground Fault									Impedance	Reactance	Potential Polarized	Current Polarized						Current	
HRK		○						○											HRK		
HRP		○						○											HRP		
HV-3	○	○					△	△		△									HV-3		
HX		○								○	○								HX		
HXS		○								○	○								HXS		
HY	○									○	○								HY		
HZ	○							△	△	○	○								HZ		
HZ-1	○		△				△	△		○	○								HZ-1		
HZ-3	○		△				△	△		○	○								HZ-3		
HZM	○						△	△		○	○								HZM		
IM								⑳		○									IM		
IW								㉑		○	○								IW		
JD								○		○					㉒				JD		
LC-1			○							○									LC-1		
LC-2			○							○									LC-2		
MF					○					○									MF		
MG-6								○	△	○									MG-6		
MN								○		○									MN		
PG								○		○					㉓				PG		
PS-1, PS-2, PS-3								○		○					㉔				PS-1, PS-2, PS-3		
RB								○		○									RB		
RC								○		○					㉕				RC		
RF					○					○					㉖				RF		
RS, RSN								○	○	○					○				RS, RSN		
SC	○	○	△	△	△	○		△	○	○									SC		
SG						○				○									SG		
SGR-1						○				○					㉗				SGR-1		
SGR-12						○				○					㉘				SGR-12		
SM-1, SM-3	○	○	△	△	△			△	○	○									SM-1, SM-3		
SV	△	△				○				○									SV		
SX						○		△		○									SX		
TD						○				○					㉙				TD		
TG-1						○		△		○					㉚				TG-1		
TH				○		△				○					△				TH		
TK						○				○					㉛				TK		
TR						○		△		○					㉜				TR		
TS						○		△		○					㉝				TS		
TSI						○				○					㉞				TSI		
TSO-1						○				○									TSO-1		
TSO-2						○				○									TSO-2		
TSO-3						○				○									TSO-3		
TSP						○		㉟		○									TSP		
TT-1						○		△		○					㊱				TT-1		
TV						○				○					㊱				TV		

- Major Characteristic Or Application
- △ Other Applications Or Characteristics
- Induction Type Relay—No Intentional Time Delay
- ⊗ Characteristics Which Are Adjustable
- △ For Direct Current Reversal Or Voltage Drop
- △ Has Thermal Element Indirectly Heated From Current Winding
- ③ Frequency Relay
- △ Has Voltage Restraint
- ④ Synchronism—Check Relay
- △ Current Balance For Phase Unbalance Or Phase Failure
- △ Used In a Differential Scheme
- ① Directional Element Operates From Negative Sequence Current And Voltage
- ② Operates From Exploring Coils Or Temperature Changes
- ⑩ Operates When Applied Watts Exceed Setting
- ⑪ Direct Current Relay
- ⑫ Current Balance For Parallel Line Protection
- ⑬ Timing Relay
- ⑭ Supervisory Relays For A.C. Pilot Wire
- ⑮ Reclosing Relays
- ⑯ Auxiliary Relay Unit For Carrier Relaying Scheme
- ⑰ Fault Detector
- ⑱ Respond To Voltage Changes With Operating Time Proportional To Voltage Change
- ⑲ Power Factor Relay
- ⑳ Telemetering Receiver
- ㉑ Telemetering Transmitter
- ㉒ Magnetizing Inrush Tripping Suppressor For Type CA, CA-4 and CA-6 Relays
- ㉓ Magnetizing Inrush Tripping Suppressor For Type HCB Relay

loss of field, there is a trend to more general use of equipment for this purpose. On some systems where loss of field would cause serious low voltage and danger of instability but where the system is operated in a way which can tolerate the loss of one machine, automatic means are being provided to disconnect the machines on loss or partial loss of field.

Fairly common is the use of a d-c under-voltage relay, a Type D-2 d'Arsonval relay in series with a resistor, connected across the slip rings for field short circuit detection; also a similar element across the field ammeter shunt for undercurrent or open field detection. These do not provide complete protection, and there are a number of installations of reactive power relays used at the generator terminals in conjunction with under voltage to trip for any field reduction which would cause serious low voltage.

On many closely knit metropolitan systems loss of field has been found to be not serious if immediately corrected. The operator attempts to restore the field, the generator in the meantime operating at somewhat reduced load as an induction generator. If he cannot restore field within a few minutes, he must trip the line circuit breaker to avoid injurious rotor heating.

Field Ground Detection—Some form of field ground detection is frequently provided. It is considered most important to detect the first ground because a second could short circuit part of the field winding causing unbalance and vibration which could wreck the machine. The a-c scheme provides complete coverage for solid grounds. The d-c scheme gives nearly complete coverage, complete if the main field rheostat is varied. In some instances vibration detectors²⁶ are used if the machine is known to be operating with a ground on its field. This will trip the unit instantly in event a second ground occurs. The over-all protection scheme frequently includes armature and bearing temperature indication and sometimes alarms. Less frequently field temperature indications are provided. The voltage regulators are sometimes equipped with over- and under-voltage protection, and, of course, over-speed protection is provided.

In addition to the protection described, generators can be equipped with over- or under-voltage, frequency, over-speed, and loss of field, and temperature responsive devices.

4. Transformer Protection

Power-transformer protection in general includes overload devices to protect the transformer and fault-detecting devices to protect the system and limit damage in event of fault in the transformer.

In the first category is the thermal relay immersed in the transformer oil but energized from a current transformer so that it responds to the copper temperature. This relay, obtainable only on new transformers, has alarm contacts to announce the approach of dangerous temperatures, and tripping contacts that close if an unsafe temperature is reached.

Oil temperature indicators perform a somewhat similar function though less effectively. For large power transformers the order of magnitudes of copper and oil time-constants are 5 minutes and 7 hours respectively. Thus,

an emergency overload for a half hour could seriously damage the transformer without reaching an oil temperature which might be reached daily after several hours of moderate load. The thermal relay responsive to copper temperature will permit the overload to be carried, if safe, but will protect the transformer otherwise.

Fault-detecting relays include percentage and straight differential schemes similar to generator-protective relays but include provisions for the magnetizing inrush current and for transformer ratio and phase shift. Also, transformers are often included with the transmission line into a single protective zone. This is particularly true of the smaller sizes such as network transformers. Many small power transformers (600–3000 kva) are provided with internal protective links that act like a single-operation breaker as the fusible element whips through the oil in the top of the tank thereby disconnecting the transformer in event of internal trouble. Others are fused to provide disconnection from the line in event of transformer failure.

A typical application of the CA relay to a star-delta connected transformer bank is shown in Fig. 4. Neglecting

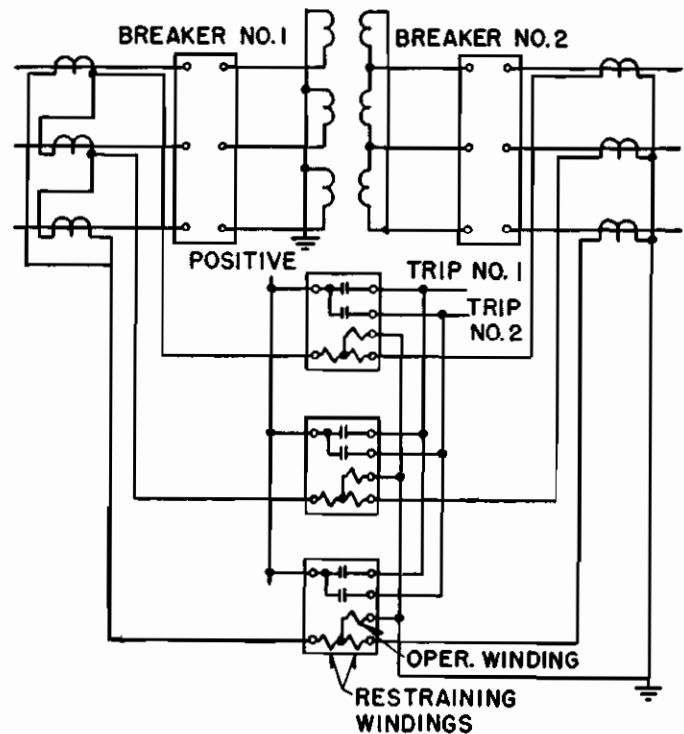

Fig. 4—Differential protection of a grounded star-delta transformer bank with CA relays. Note that the current transformers are connected star on the delta side and delta on the star side.

exciting current, the top phase line current on the right hand side is made up of the difference of two transformer currents or the difference of the two top phase line currents on the left hand side. Consequently, it is compared with this difference current obtained by connecting the left hand current transformers in delta. These two currents are not exactly equal, even with a perfectly sound transformer bank, because of the magnetizing current.

Magnetizing Inrush—While under steady operating conditions, the magnetizing current amounts to only 5 or 10 percent, it may rise to several times full load current when a transformer is first energized, and decay rather slowly from this value; that is, it may be as much as full load current even a full second after the transformer is first energized. This magnetizing inrush current is fully displaced and hence, contains a large d-c component.²³ The inrush current is greatest if the switch is closed at the zero point of the voltage wave. Its magnitude depends also on the residual excitation and on the leakage reactance in the supply circuit and transformer primary. Data for determining the value of the magnetizing inrush is given in Chap. 5. Ordinarily the residual flux density is low when the transformer is first energized. However, when a severe fault occurs near a transformer at a time when its flux density is maximum (voltage zero), and if the fault is interrupted an odd number of half cycles later, the residual flux at the instant of re-energizing may approach normal density. As this requires the fault to start and stop at zero voltage, it is seldom fully realized.

The rate of decay of the magnetizing inrush current depends on losses and is particularly slow when a large bank is paralleled with one already operating and quite near to a large generating station.²⁰ The d-c component, which flows at first over the supply circuit, transfers to a circulating current between the two transformer banks, and this dies out very slowly because of the high L/R ratio. For example, when the magnetizing current has dropped to 50 percent of full load in a 60-cycle transformer having 0.25 percent primary resistance, the reactance to resistance ratio is $200/.25$ or $800/1$. The corresponding L/R ratio or time constant which determines the rate of decay of the d-c component is 2.1 seconds.

The Type CA normal-speed differential relay most commonly used for transformer protection has a 50-percent differential characteristic and 2.5-ampere minimum trip. It is prevented from operating during the magnetizing inrush by the large restraint, the inverse time characteristic, and the braking action of the direct current on the induction disc. It is found adequate in all but the extremely rare cases where one large bank is paralleled with another.

When the differential relay cannot, because of its inherent characteristics, avoid tripping on the magnetizing inrush, a timing device can be used, which desensitizes the protection during the timing interval by requiring a drop in voltage in addition to operation of the differential relay to produce tripping during the inrush period. This device, known as a magnetizing-inrush tripping suppressor,¹ is used primarily with high-speed differential relays or with pilot-wire relays when a transformer is included as a part of the line.

High-speed transformer differential protection (Type HA relay) is required in certain circumstances to coordinate with other high-speed system protection, particularly where stability is critical. It must be used with the tripping suppressor as outlined above. This unit is therefore built as an integral part of the Type HA transformer relay.

Three-Winding Transformers are protected in the same manner as two winding transformers except that the

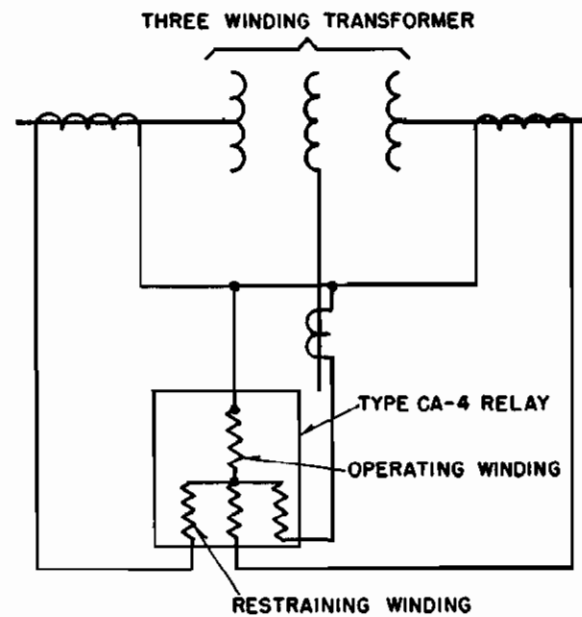

Fig. 5—Single line diagram showing the arrangement of circuits when using the CA-4 relay for the differential protection of a three-winding power transformer.

Type CA-4 relay for this purpose has three restraining coils to be associated with the three transformer windings as shown in Fig. 5.

Regulating Transformers—Regulating transformers for voltage and phase-angle control constitute a special problem because of the change in ratio taps during operation. Figure 6 illustrates the most modern differential relay protection for such a unit. A Type CAM relay, Fig. 2(p), having one disk and two electromagnets is arranged to trip if the current in the shunt-exciting winding of the regulator greatly exceeds the proper proportion of the series-line current. For example with a ± 10 percent voltage regulator, a typical relay would operate for any current in the shunt winding greater than 11.5 percent of the

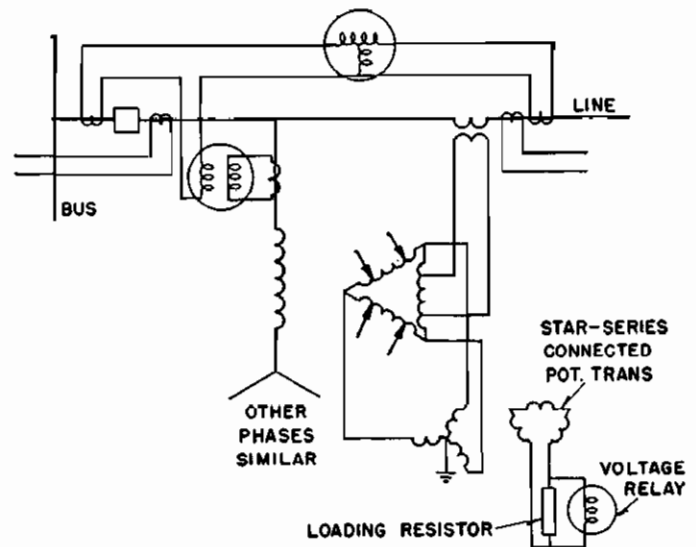

Fig. 6—Typical large regulating transformer protection.

line current. This provides sensitive protection for the shunt transformer. In addition normal two-winding transformer-differential protection is applied around the entire unit, providing overlapping protection with the bus and line protection and guarding the series transformer. It is difficult to provide complete protection to the series transformer and tapped regulating windings. Optimum use is made of ground protection, for example as shown in Fig. 6. However, the possibilities of this protection vary with the arrangement of windings and whether grounded or not.

Remote Trip for Transformer Faults—Because of the high record of reliability of large power transformers, a circuit breaker between the high-voltage side of the transformer and the line frequently cannot be justified, purely for protection of the transformer, and the transformer is very little hazard to the line. However, an intermediate measure costing much less than the high-voltage circuit breaker is frequently provided to trip the remote circuit breaker (or breakers) necessary to clear in the event of a transformer fault. The transformer differential relay is sometimes used to initiate a remote trip signal over a carrier or pilot wire channel, particularly if the channel is already available for some other purpose. Another method is to close a fast spring-operated high-voltage grounding switch in response to the relay indication. This trips the ground relays at the other terminals of the line, at the expense of some added shock to the system.

5. Bus Protection

The advantages of bus protection in clearing faults rapidly from a system are well recognized by the industry and the provision of relay protection for major station busses has been standard practice for a number of years. The problems involved in such protection are also quite well known. One of the principal problems is the saturation of current transformers by the d-c transient component of the short-circuit current as in Fig. 7. In severe

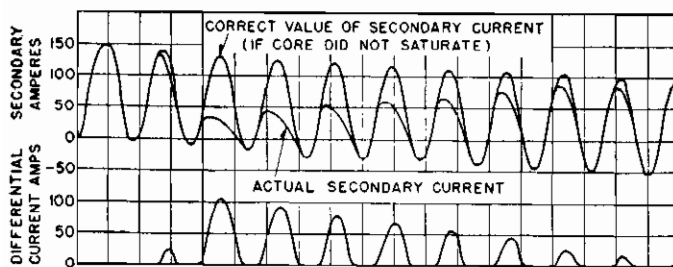

Fig. 7—False differential current caused by d-c saturation of current transformers during the condition of an asymmetrical short circuit. The d-c time constant for the case shown is 0.14 sec. The incoming transformers are assumed not to saturate. Thus the error current of the outgoing transformer is the differential current through the relay.

cases the d-c transient component may require 100 times as much flux capacity in the transformer as is required by the a-c component to completely prevent saturation.

There are a number of successful solutions to this problem, as well as the fault-bus scheme,^{11,16} which completely avoids it. One is the use of large current transformers which will not be saturated by the d-c component. These

are used in the simple differential scheme, Fig. 10(a), with low-resistance leads to minimize the current transformer requirements. The formula specifying the requirement of iron cross section, turns and lead resistance for nonsaturation¹⁸ is:

$$\frac{E_s}{R} = 4.44 IT$$

where T is the short-circuit current d-c time constant in cycles. I_s is the a-c exciting current in the secondary, selected as the threshold of saturation. It would be taken as less than the relay setting by a suitable factor of safety.

E_s is the required secondary rms, a-c voltage corresponding to I_s on the a-c saturation curve of the current transformer. This determines the needed iron cross section and turns, or the iron if turns are fixed.

I is the crest value of symmetrical subtransient current, secondary amperes.

R is the secondary circuit resistance in ohms, including the transformer winding and leads up to the relay (or point at which all current transformers are paralleled.)

The a-c flux is neglected. It is usually relatively small as the ratio of maximum d-c flux to a-c flux is $2\pi T$ or 37.7 for a 6-cycle d-c time constant.

For $R=0.5$ ohm, $I=100$ amperes, $T=6$ cycles, and taking I_s as one ampere, in considering a 5-ampere relay setting, E_s becomes 1332 volts. A current transformer which would generate this voltage at 1.0 ampere exciting current is very large. Thus, this is a bull-by-the-horns solution, and the size, weight, and cost can be afforded only in the most important installations. However, it does provide the possibility of instantaneous tripping without any time delay.

A method¹⁸ has been developed for calculating with reasonable engineering accuracy, the time-to-saturate with offset currents, and the time and current settings required to prevent misoperation with time-delay overcurrent relays and usual current transformers.

Induction Type Overcurrent Relays—On busses of moderate time constant, say 0.1 second or less, and with somewhat better than average current transformers, satisfactory protection can be obtained with a straight differential scheme, Fig. 8, using a fast induction element. A small ratio of maximum to minimum fault is favorable to this application. Relaying times of the order of 3 or 4 cycles for maximum faults and up to 8 or 12 cycles on minimum faults can be obtained in some cases. As mentioned, the performance can be predicted.¹⁸ However, the time delays involved in less favorable cases are frequently so long as to point the need of a better solution.

Even on substation busses having a d-c time constant as short as 0.01 second, false tripping has been experienced with 300/5 bushing current transformers and standard induction relays in the connection of Fig. 8, with 4 ampere tap, 0.5 time lever, giving 0.15 second time at 10 times tap, and with a fault current of 13 000 amperes. While this has been overcome by changing to 1200/5 current transformers, nevertheless present practice would be to install ratio-differential relays in these cases, providing both greater sensitivity and greater safety factor.

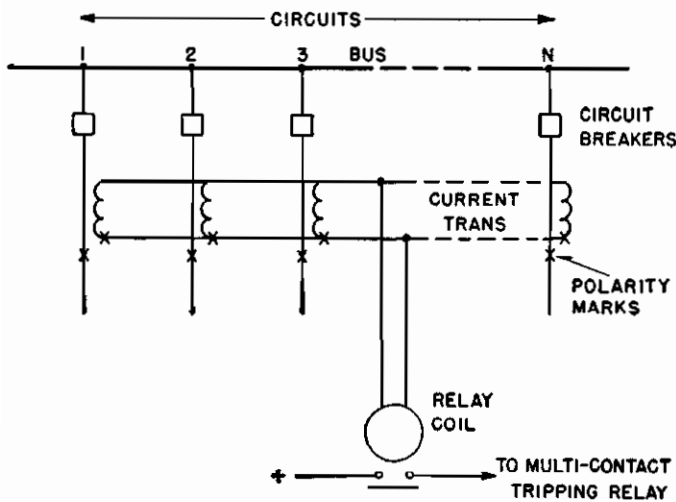

Fig. 8—Bus-differential-current relay scheme.

Multirestraint Ratio Differential Relays—Relays¹⁷ have been developed which will not operate falsely even when used with normal sized current transformers which saturate due to the d-c component of current. These are multirestraint relays, connected as in Fig. 9; however, their success is due also to exploitation of variable percentage characteristics, and the tendency of the d-c component to brake, rather than drive, the induction disk.

No small part of this development is the reduction of the operating limits to a few simple rules which insure safe application. This relay scheme provides operation generally in from three to six cycles and can be set as low as one percent of the maximum through-fault current.

Linear Coupler Scheme—The multirestraint relays just described may, of course, be used when the setting does not need to be as low as one percent of the maximum-through-fault current. However, on busses where a setting of four percent or more of the maximum through-fault provides the requisite sensitivity, a simpler and faster scheme (one cycle) can be used known as linear-coupler bus protection.^{21,27} The linear coupler is an air-core mutual inductance used directly in the primary circuit in the same manner as a current transformer except that the secondaries are usually connected in series, as shown in Fig. 10, instead of in parallel as are current transformers, Fig. 8.

The secondary induced voltages are proportional to the

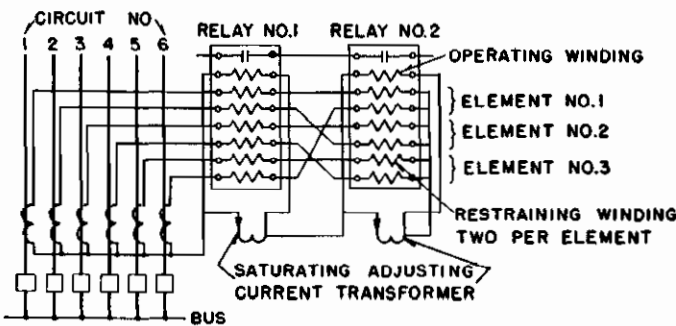

Fig. 9—Protection of a six-circuit bus using two multi-restraint relays per phase.

primary currents, a ratio of five volts per 1000 amperes being commonly used. These voltages, which add up to zero for through faults and to a value proportional to the fault current for internal faults are joined in a series loop to the relay as shown in Fig. 10. The ± 1 percent tolerance

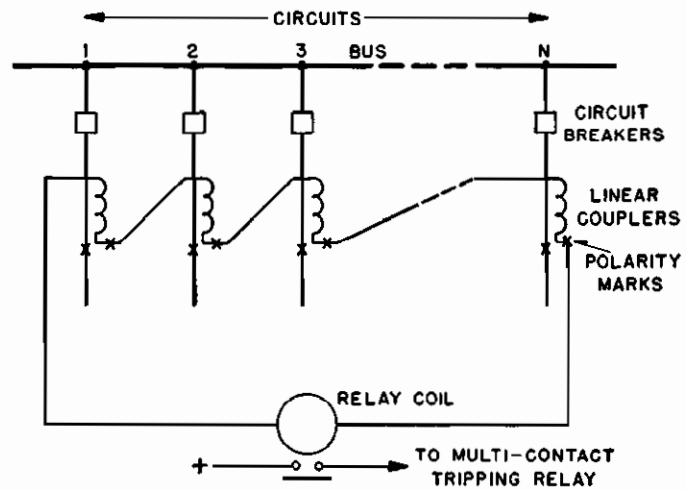

Fig. 10—Linear-coupler bus-protection scheme.

within which the mutual inductances are held commercially, limits the maximum possible false differential to 2 percent. Thus the minimum setting of 4 percent allows a 2:1 factor of safety. Solenoid elements, Fig. 2(a), are used for settings down to about 1500 amperes on a 6-circuit bus, and polar elements, Fig. 2(j), with saturating transformer and Rectox for lower settings.

Impedance Schemes—Busses having reactors in a majority of the feeders and possibly in the bus-tie circuits provide the possibility of protection by impedance relays.¹³ Impedance or modified-impedance elements can be used, see Fig. 2, (i) and (k). For a fault on the bus, the maximum impedance measured is that of the arc which is taken as about 300 to 500 volts per foot for current above 500 amperes. Considering the possible arc length during the first few cycles of fault, a maximum arc voltage can be computed and this, divided by the minimum fault current gives the greatest fault impedance encountered for internal faults, that is, for faults on the protected bus. Provided this impedance is smaller than the impedance from the relay to a fault anywhere beyond the reactors, a basis of discrimination exists and the impedance scheme can be used.

Two relay arrangements are used. When the bus tie circuits include reactors, separate impedance relays can be used on each generator or transformer feed to the bus, operation of any of which will trip the bus. This arrangement is most feasible when the generators and transformers are matched, acting as a unit, and the generators on the bus are either high and low pressure units of a single combination or are treated as a single generator. The other arrangement requires totalizing all of the main feeds to the bus and the use of a single set of impedance relays. The grouped main sources provide the possibility of a large false differential current for through faults on one of these main circuits. The voltage is also low under this condition

if the source circuits are not equipped with reactors. Usually a fast induction relay, Fig. 2(d), is used together with adequate current transformers in the main feeds so that it will not operate for through faults on those feeders. Combined impedance and fast-induction-element operation is then required to trip the bus.

Directional relays can be used in a variety of ways, either as the basic protection, tripping when fault current flows into and not out of the bus,²⁴ or as an adjunct for determining which of several bus sections included within a common differential protective zone is in trouble.¹³

Fault Bus—For new and certain existing segregated phase busses, the fault-bus scheme^{11,16} provides a distinctly different mode of attack to the bus protection problem. All metal parts to which the bus may flash are connected together and grounded through a current transformer and relay. This construction lends itself particularly well to metal-clad switch-gear. The entire cubicle or switchhouse is insulated from ground except for the ground connection through the current transformer. The simplicity of this scheme is strongly in its favor where the construction permits its use. However, it is sometimes difficult to secure overlapping protection with the adjacent system elements.

Summary of Bus Protection—While personal preference, experience, and factors peculiar to a particular installation play a large part, some of the general factors that lead to the selection of one or the other of the several schemes are described below. One-cycle operation, simplicity, and savings in cable costs, as compared with the multirestraint scheme, are favorable to linear couplers.

Quite adequate speed (3–6 cycles), the use of existing current transformers, the use of current transformers which can be used for certain other purposes also (such as back-up protection), simple application rules, and ability to set for minimum faults one percent of maximum-through-fault sometimes eliminating need of separate ground relay, are all favorable to the multirestraint system.

Existence of reactors and the cost or difficulty which would otherwise be involved of installing current transformers on all feeders, favors impedance schemes.

The fault-bus scheme is limited to cases where the structure can be insulated from ground, but in these cases its simplicity is favorable.

Simple time-delay over current frequently involves excessive delay, but if used with ordinary current transformers, it may be lowest in cost.

The directional schemes are used to good advantage by some and have the advantage of securing fast operation with ordinary current transformers, but are considered less favorably by others because of the number of contacts to be co-ordinated for correct operation.

In most cases, spring-operated, manually-reset auxiliary tripping relays are used, unlatched electrically by the main differential relays. These trip the necessary circuit breakers and provide lockout.

6. Transmission Line Protection

As systems have grown in extent and complication, from the simple radial systems of the early 1900's to the looped and interconnected systems of the present, the task imposed

on the protective relay has become increasingly more difficult. However, developments in the protective relaying art have kept pace with the requirements. Through the introduction of improved relaying principles and better use of the old principles, high-speed action can be obtained on the complicated systems of today with better overall results than that previously possible on the simple radial systems.

Starting with the induction-type overload and reverse-load relay in about 1901, which used power for discrimination, the directional overcurrent relay with inverse-time characteristics was introduced in 1910. Later, in 1914, the definite minimum time characteristic was added. This simplified the relay coordination problem and is still used in the greater proportion of overcurrent relays today. The first impedance-, or distance-measuring relay, the type CZ, was introduced in 1922.

Shortly after this the importance of speed in fault clearing, particularly with inter-connected systems, was beginning to receive merited attention and in 1929 the high speed impedance relay, type HZ, operating in one cycle and using the balance beam principle, was introduced³¹. At about the same time, circuit breaker operating times were lowered from about 24 cycles to 8 cycles.

The reductions of overall fault clearing times that could be realized by these progressive changes in the art⁸² are shown in Fig. 11.⁶⁴ Starting with times up to 2 seconds for the slow-speed relays and 24 cycle breakers, the change to high-speed relays brought the time down to about 27 cycles with about one second in the end zones.

Decreasing the circuit-breaker operating time to 8 cycles further lowered the overall clearing time to 8 to 10 cycles for about 80 percent of the line length but left times of about 27 cycles in the end zones.

In about 1935 carrier current relaying passed out of the experimental stage^{51,52,53,54} and reached general acceptance, making available uniform high speed action throughout the entire section. Shortly later, in 1938, the Type HCB relay⁶² based on symmetrical component principles made one-cycle operation practical over two a-c pilot wires. Summarizing, and referring to Fig. 11, with 8 cycle breakers the total clearing time is under 0.2 seconds for pilot-wire or carrier current relaying, 0.2 seconds (with 0.5 seconds for the end zones) for high speed distance relaying and 0.2 to 2.0 seconds or longer for overcurrent protection, depending on the layout.

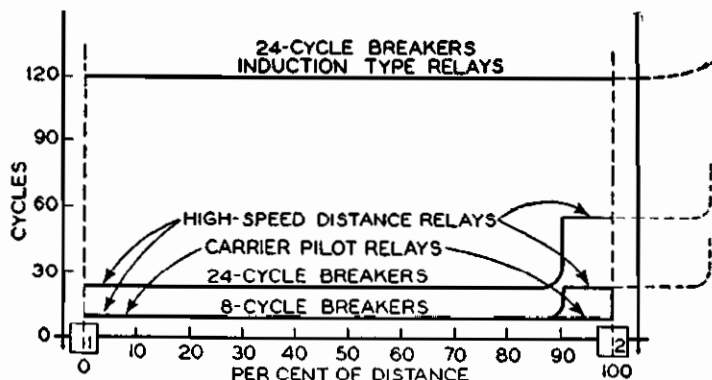

Fig. 11—Reduction of fault clearing time obtainable through the use of higher speed circuit breakers and relays.

notations as to relay types and settings, these symbols compress the otherwise complicated picture of complete system protection into a form that can be readily visualized. The standard symbols are given in Table 3. Their use has been illustrated in Fig. 12.

TABLE 3—RELAY SYMBOLS

(a) SYMBOLS FROM THE A S A STANDARDS.

OVERCURRENT		DIRECTIONAL OVERCURRENT	
OVERVOLTAGE			
UNDERVOLTAGE			
DISTANCE		DIRECTIONAL DISTANCE	
		POWER DIRECTIONAL	
BALANCED OR DIFFERENTIAL CURRENT			
OVER FREQUENCY			
UNDER FREQUENCY			
OVER TEMPERATURE			
BALANCED PHASE		PHASE ROTATION	
PILOT WIRE (CURRENT DIFFERENTIAL)		PILOT WIRE (DIRECTIONAL COMPARISON)	
		CARRIER PILOT	

Where the operation of a relay is conditional upon the flow of ground current (residual or zero sequence) this shall be indicated by prefixing the ground symbol thus:-

Residual Overcurrent

Other prefixes such as (P) and (N) to indicate operation on positive or negative phase sequence quantities, and suffixes to indicate the relay types, inclusion of instantaneous trip attachments, etc. may be added at the discretion of the user.

(b) FREQUENTLY USED VARIATIONS OF THE STANDARD SYMBOLS.

OVERCURRENT GROUND WITH INSTANTANEOUS ATTACHMENT	
GROUND DIRECTIONAL WITH INSTANTANEOUS ATTACHMENT	
DIRECTIONALLY CONTROLLED	
POWER DIRECTIONAL WITH INSTANTANEOUS ATTACHMENT	
DIRECTIONALLY CONTROLLED	
BUS CURRENT DIFFERENTIAL	
BUS GROUND DIFFERENTIAL	

9. Fault Frequency and Distribution

About 300 disturbances (or one per ten miles) occurred per year in a typical system operating 3000 miles of 110-kv circuit. This system used mostly overcurrent and directional relays, and in a 4-year period experienced 2800 relay operations of which

- 92.2 percent were correct and desired
- 5.3 percent were correct but undesired
- 2.1 percent were wrong tripping operations
- 0.4 percent were failure to trip

The faults were as follows:

Lightning	56 percent
Sleet, Wind, Jumping Conductors	11 percent
Apparatus Failure	11 percent
Close-in on Fault	11 percent
Miscellaneous	11 percent

Relative Number of different kinds of faults—
The relative numbers of different types of faults vary widely with such factors as relative insulation to ground and between phases, circuit configuration, the use of ground wires, voltage class, method of grounding, speed of fault clearing, isokeraunic level*, atmospheric conditions, quality of construction and local conditions. Thus the figures given below serve merely to indicate the order of prevalence and emphasize that there are usually a great many more line-to-ground faults than faults of other types.

Three-Phase Faults	5 percent
Two-Line-to-Ground Faults	10 percent
Line-to-Line Faults	15 percent
Line-to-Ground Faults	70 percent
Total	100 percent

10. Overcurrent Protection

The general plan of coordination with overcurrent relays on a radial system is shown in Fig. 13. The time shown in each case is the fastest operating time for a fault at the location of the next device in sequence. At lighter generating capacity the fault currents are reduced and all operat-

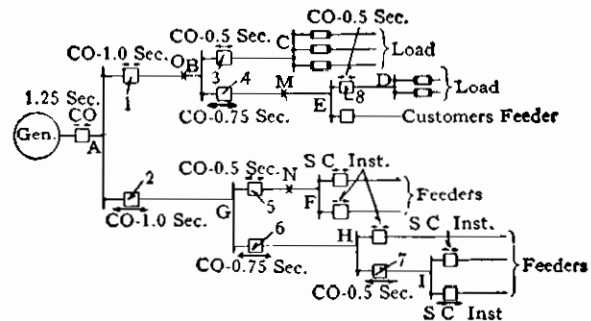

Fig. 13—Coordination of overcurrent protection on a radial power system.

ing times increase, but because of the inverse time characteristics of the relay the margins between successive relays also increase.

Relays used with feeder circuit breakers must be coordinated with fuses of distribution transformers and with the main and branch line sectionalizing fuses.⁸³ Several characteristic curve shapes are available in different designs of the induction-type overcurrent relays as illustrated in Fig. 14. These provide latitude in selecting the relay that coordinates best with the fuse curves at the current involved.

The definite minimum time characteristic provides a ready means for coordinating several relays in series with only an approximate knowledge of the maximum current, and results in relatively small increase in the relay time as the fault current is lowered. It is used in the majority of overcurrent relay applications. The inverse and very inverse characteristics are sometimes more favorable where close coordination with fuses is required. They also make it possible to take advantage of the reduction of maximum fault current as distance from the power source increases. Several relays in series can be set for the same time for

*Number of storm-days per year.

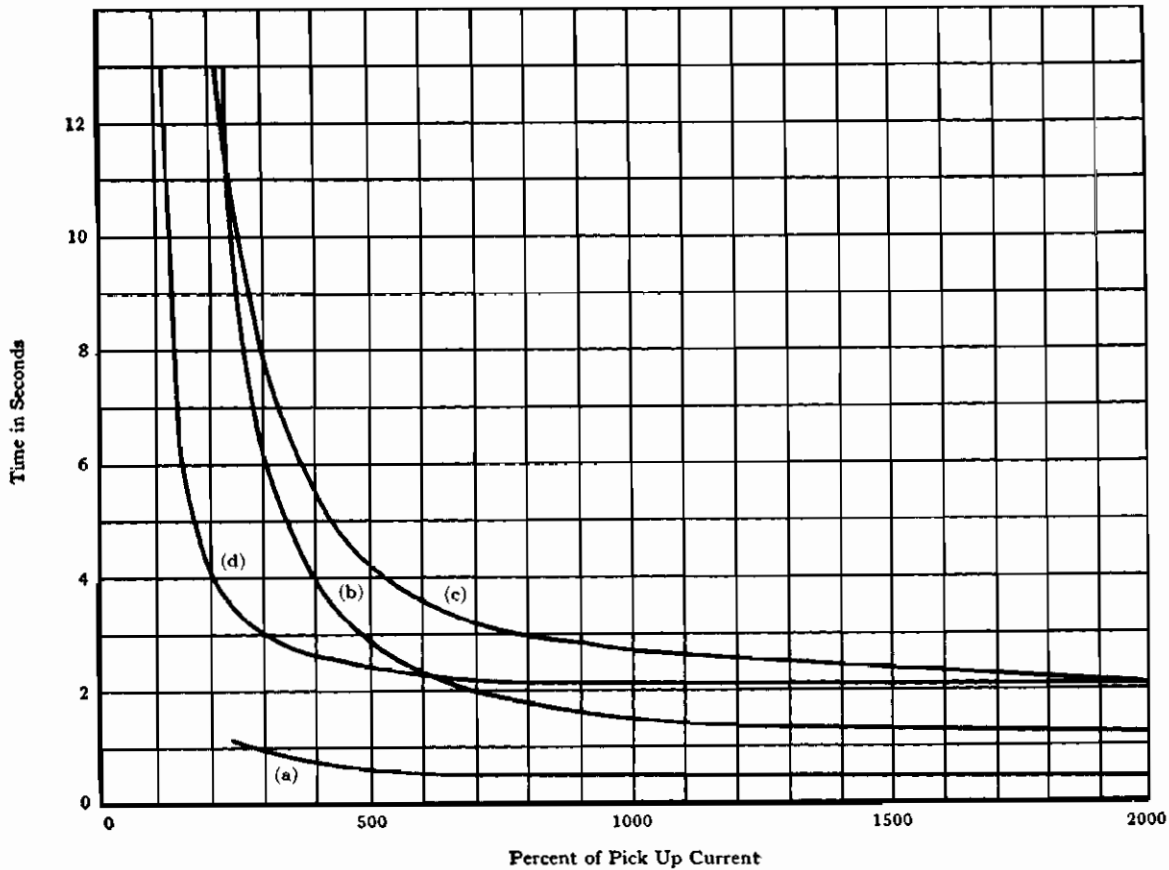

Fig. 14—Characteristics of various induction type overcurrent relays.

- (a) Type COH.
- (b) Very inverse-low energy relay, Type CO.
- (c) Inverse-low energy relay, Type CO.
- (d) Standard, definite minimum time, Type CO relay.

faults immediately beyond the relay and still provide the requisite 0.25 second or more margin for fault beyond the next relay because of the lower current value for fault in that location. For example the timing on curve (b), Fig. 14, doubles when the current is reduced from 700 percent to 400 percent of pick-up value. Several settings of 0.3 second at 700 percent could be used in series, while still having 0.3 second margin between successive relays if the fault current dropped in the ratio 7 to 4 between successive locations.

The choice of relays is also influenced in certain cases by the lower burden of the “low energy” and “very inverse” types.

11. Normal-Speed Impedance Relay*

The time-distance tripping characteristic of the Type CZ normal-speed directional distance relay is illustrated in Fig. 15, which shows a number of line sections in series. This may equally well be a loop, the two ends of the section shown being at the same supply point. The tripping time of the relay increases in direct proportion to the distance from the relay to the fault, except that the minimum time is about 1/4 second for a fault at the relay. Each relay is

*The trend is toward the high-speed impedance relay described in Sec. 12 even for intermediate voltage transmission lines.

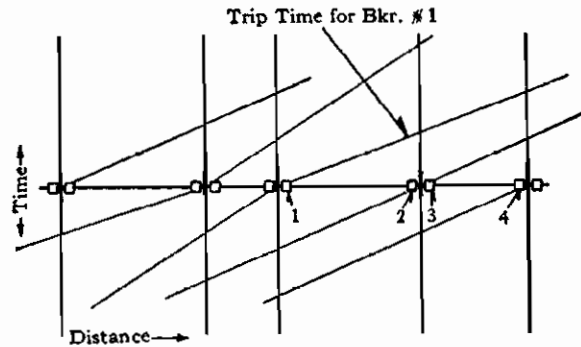

Fig. 15—Time-distance curves of the Type CZ relay. The slope of the curve is changed by varying the resistance in series with the potential coil. The minimum operating time with zero voltage on the relay is about 1/4 sec.

adjusted to trip in approximately 3/4 second for a fault at the next bus, except as will be noted.

It is essential that for a fault near bus 4, breaker No. 3 be tripped in preference to breaker No. 1. Thus the operating time of relay No. 1 must exceed that of relay No. 3 for fault at location No. 4 by one circuit breaker operating time plus margin. For 8-cycle breakers a reasonable breaker time plus margin is 0.4 second.

The operating time for faults anywhere on the system can be readily determined by drawing the straight lines representing the relay times, using whichever criterion rules in each case; that is, 0.75 second at the next bus or 0.4 second above the next relay at the second bus. The particular time values mentioned are typical only. The relay tripping time is independent of current magnitude once the overcurrent setting has been exceeded and timing thereby initiated. Thus variations in the amount and location of connected generating capacity, or switching lines out, does not materially affect the coordination of the distance type relays over the remainder of the system.

The normal-speed type CZ relay is not usually employed on lines shorter than those in which at least 5 volts secondary result at the relay for a fault at the other end of the line. As the relay is normally subjected to full voltage and must discriminate on values between zero and that for a fault at the other end of the line, the operating forces approach the frictional forces below this limit.

12. High-Speed Impedance Relays, HZ and HZM

The high-speed distance type relay has the step type time-distance characteristic illustrated in Fig. 16, obtained

relay. The third-zone impedance element, which operates when either of the other two elements operate, is used to start the timer that closes first a second-zone timing contact T_2 , and later a third-zone timing contact, T_3 .

Thus for a fault in the first 90 percent of the section, known as zone 1, the contacts D and Z_1 operate, giving immediate high-speed tripping in one to three cycles, as indicated in the timing chart of Fig. 16. While the other elements also operate their action in zone 1 is unimportant because the circuit breaker has already been tripped. Thus, in zone 1 the tripping time is that of elements Z_1 and D .

For the second zone, which extends approximately to the middle of the next section, contacts D , Z_2 and T_2 in series do the tripping, provided the fault lasts for the time setting T_2 . If the fault is in the next section it will be cleared by the proper breaker in advance of T_2 operation, although back-up protection is provided by the second zone setting extending into the next section. This also provides operation for bus faults if they are not previously cleared by bus-protective relays.

The third zone, corresponding to tripping through the contacts of elements D , Z_3 , and T_3 , completely overlaps the next section, providing complete back-up protection. It must of course be timed selectively with the T_2 timing of the next section.

The flexibility of this arrangement in molding its characteristic to various section lengths and breaker and relay times is apparent. The highly successful operation of several thousand such relays in service indicates that for practical systems, which of course depart in many ways from the simple ideal case represented in Fig. 16, the flexibility is sufficient to secure in general the operation outlined.

For good operation the line should be electrically long enough so that there will be at least 5 percent voltage at the relay for a fault at the next bus, although in special cases successful operation can be obtained somewhat below this limit.

In some cases the CZ characteristic lends itself better to coordination with other back-up protection, but the high speed of the Type HZ first-zone element is desired. For this purpose these two elements have been combined and make available the time-distance curve shown in Fig. 18.

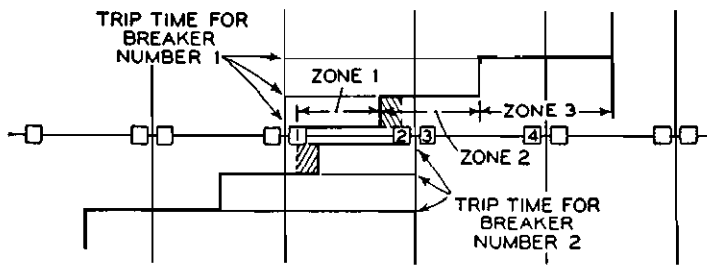

Fig. 16—Time-distance curves of the Type HZ step type, high speed distance relay. When carrier current is added the time is reduced to that shown dotted.

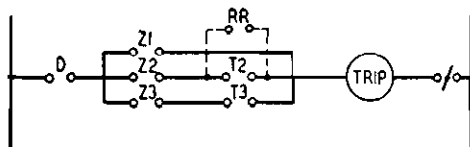

Fig. 17—Contact circuit for producing the stepped time-distance characteristic shown in Fig. 14.

- Z_1 —First Zone Impedance Element Contact.
- Z_2 —Second Zone Impedance Element Contact.
- Z_3 —Third Zone Impedance Element Contact.
- T_2, T_3 , timer contacts having separately adjustable time settings.
- D —Directional element contact.

by separate directional, impedance, and timing elements with contacts connected as shown in Fig. 17. There are a total of three balance-beam type impedance elements, each arranged with a current operating winding at one end of the beam and a voltage restraining winding at the other. When the ratio of voltage to current falls below the impedance setting of the relay high-speed action closes the contacts.

The impedance elements Z_1, Z_2 , and Z_3 are set for successively greater distances. The directional element closes only for faults in the desired tripping direction from the

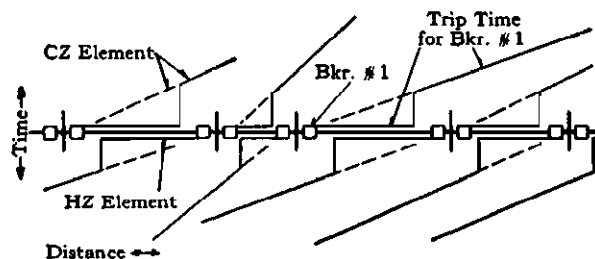

Fig. 18—Typical time-distance characteristics of the HCZ relay. Note the slope of the CZ element necessary for different length sections to secure selectivity.

*Modified Impedance Relay, Type HZM.*⁴¹ The operating characteristic of the standard type HZ impedance relay is nearly independent of the phase angle between current and voltage. That is its "reach"-vs.-angle characteristic is a circle centered at the origin as shown in Fig. 19. This

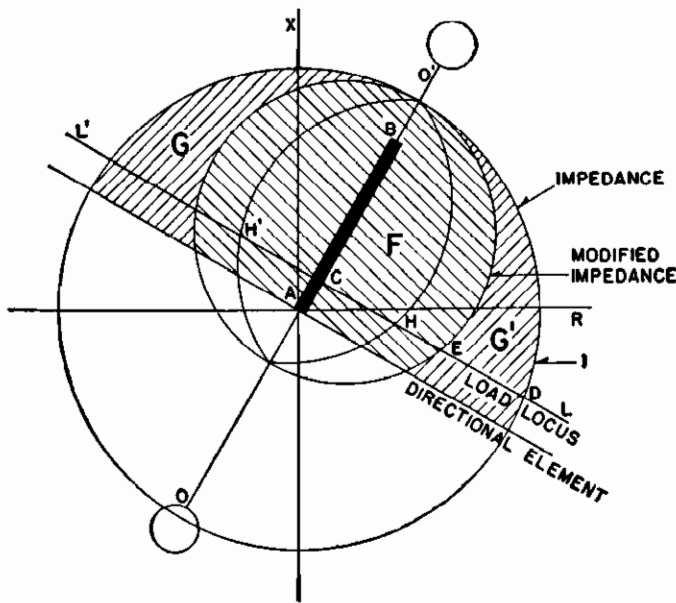

Fig. 19—Modified-impedance characteristics provides improved selectivity between heavy load swings and line faults.

characteristic provides adequate discrimination between load and faults in a majority of cases. However, increased use is being made of the Type HZM relay having the modified-impedance characteristics shown in Fig. 2(k) for the protection of long or heavily-loaded lines. It is necessary that the relays permit the maximum expected steady or swing loads without tripping. On long or heavily-loaded lines, and especially if high-speed reclosing is used, it becomes more and more difficult for the relays to distinguish between heavy swing loads and fault conditions. The modified-impedance relays provide the improved discrimination necessary in these cases.

Their operation can best be shown by plotting on a single diagram the impedances corresponding to three things.

1. Faults on the protected line.
2. Heavy load swing conditions.
3. The relay characteristics.

These are shown for a simple case in Figure 19. Considering the simplified case of a two-machine system with all impedances having the same R/X ratio, let the system impedance be laid out on a resistance-reactance chart as the line $OABO'$ representing the impedance from one machine to the other. The transmission line being studied is a tie-line constituting the section AB , shown heavy, of this total impedance. If R and X axes are drawn through A , as shown, the impedance with respect to these co-ordinate axes are those seen by the relays at A . Thus, the locus of impedances seen by the relay at A for a solid fault on the protected line consists of the line $A-B$, having impedances from zero up to the full line impedance.

It can be shown that if the generator voltages at the two ends of the system are equal in magnitude and are at first in phase, then are moved out-of-phase, resulting in load transfer over the line $A-B$, the impedance locus viewed from A is along the line $L-L'$. That is, the impedance seen by a relay at A , for the load condition, is the impedance

vector drawn from the origin, A , to a point on the line $L-L'$. This line bisects $O-O'$ perpendicularly. The no-load points, corresponding to zero angle between machines are at infinity either way along $L-L'$, whereas the 180 degree out-of-phase condition is at the intersection, C . All intermediate loads are somewhere along the line $L-L'$, the point L corresponding to power flow A to B and point L' to power flow from B to A .

The large circle with center at the origin, A , represents a pure impedance characteristic, as in Fig. 2(i). The smaller circle having the same "reach" beyond B is a modified impedance characteristic, Fig. 2(k). It can equally well trip for all faults on the protected line but is less likely to trip for very heavy loads or load swings. Successively heavier loads are represented by progressing through points L , D , and E along the load locus. The modified characteristic taken with directional element, trips for faults or loads in the cross-hatched area F , while the pure impedance element trips also in the areas G and G' . Thus the modified characteristic permits heavier loads without tripping.

When carrier relaying is used so that tripping requires closure of the relay at each end of the line, the small circle, for the relay at A can be advantageously shifted further to the right, so that the combined action of this relay and its mate at the other end of the line limits carrier tripping to the restricted zone between the two arcs at H and H' . The back-up protection must be given sufficient timing to ride through swings or eliminated entirely except for a high-set, long-time element.

The modified impedance element provides for independent adjustment of the radius of the circle and the location of the center as shown in Fig. 2(k) and hence makes possible the superior discriminating characteristics needed for long or heavily-loaded lines as outlined before.

13. Carrier Pilot Relaying

A pilot channel such as that obtainable by carrier current over the power circuit, or by a microwave beam, provides the possibility of simultaneous high speed tripping of both circuit breakers in one to three cycles for faults throughout the entire section. The significance of fault-clearing speed on system stability is treated fully in Chap. 13. However there are, altogether, a number of reasons why carrier-current relaying has been employed in preference to other systems. These are:

1. *Stability*—Simultaneous clearing improves system stability and increases the loads that can be safely carried over parallel interconnecting lines.
2. *Quick Reclosing*⁶³—Simultaneous tripping is essential to fast reclosing, the combination being particularly effective in increasing stability with single tie lines.
3. *Shock to System*—System shock, evidenced by voltage dips and dropping of synchronous load is lessened by fast clearing.
4. *System Design Flexibility*—Desirable system arrangements that can not be relayed with sufficient speeds otherwise, are possible with carrier relaying.
5. *Growth of Faults*—The more serious three-phase and double-ground faults generally originate as line-to-line or single-ground and with sufficient speed of clearing the spreading to other phases is greatly reduced.
6. *Ground Relaying Improved*—On systems where high-speed

ground relaying is not feasible otherwise, carrier pilot relaying provides an ideal solution.

7. *Out-of-Synchronism**—The carrier channel provides means for preventing operation of protective relays by power swings or out-of-synchronism conditions, yet clearing faults during such conditions.
8. *Simultaneous Faults*—The added basis for discrimination makes possible superior relay performance under simultaneously occurring faults.
9. *Joint Use*—From an economic point of view joint use of the carrier channel for point-to-point communication, or for control or remote metering, may indicate the use of carrier pilot where the relaying requirements alone do not justify it.

Carrier relaying operates on the principle of tripping quickly all terminals through which power flows into a line provided fault power does not flow out at any other terminal. If fault power flows out at any terminal, that terminal continues to transmit a straight telegraphic carrier signal over the line, which is picked up by all other terminals on that particular line and prevents tripping. No time delay is necessary for internal faults since tripping for external faults can be prevented by the carrier signal. Since carrier is not transmitted for internal faults, the short-circuiting of the carrier channel by the fault is of no consequence.

Directional Comparison System—The type HZ or HZM directional comparison system utilizes the stepped impedance elements, Fig. 2(i) or (k), as its basic actuating elements, (see section on High-Speed Impedance Relay).

*Can also be accomplished without carrier,** with some differences.

Corresponding second and third zone ground over-current elements, Fig. 2(b), are provided. The carrier control has the net effect of eliminating all second-zone time delay for faults within the protected section. This is accomplished by closing of the contact *RR*, Fig. 17, whenever a fault is present and carrier is stopped because the direction of flow is "inward" at each end of the line.

The mechanism is indicated generally in Fig. 20. Occurrence of a fault anywhere within reach of the third zone relays, closes *Z₃* starting carrier and setting up a circuit so that the receiver relay will close if carrier is removed by some other action. If the fault is internal, *D* and *Z₂* close, stopping carrier transmission from either end of the line. The receiver relays, *RR*, immediately complete the trip circuit. If the contact circuit *RR* is opened manually the carrier can be cut out and a stepped-distance relay scheme remains. Thus the carrier is thought of as simply eliminating the time delay in the end zones, indicated by the shaded areas in Figure 16. The stepped-distance elements and an inverse-time ground current element provide the back-up protection in this system.

Phase Comparison System—The phase comparison system differs functionally in that the current directions or phases at the two ends of the line are compared rather than the power directions. Networks are used to derive a single-phase function of the line currents as in the pilot-wire relay. This function may be referred to simply as the "current" at each end of the line since it is a measure of the several phase currents.

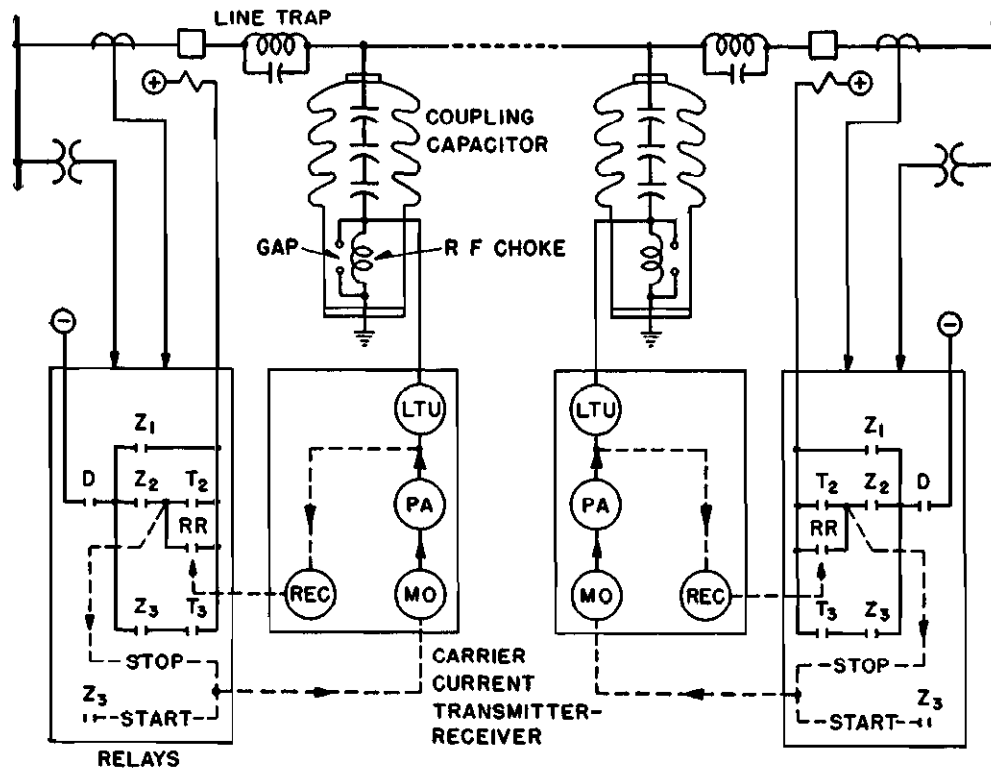

Fig. 20—Carrier current relay system including relays, carrier current transmitter-receivers, coupling capacitors, and chokes.

Dotted lines indicate symbolically the carrier controls
 MO—Master Oscillator REC—Receiver
 PA—Power Amplifier LTU—Line Tuning Unit

If the currents at the two ends of the line are in phase and of fault magnitude, carrier is transmitted on alternate half cycles of current from either end of the line, resulting in substantially continuous carrier on the line from one end or the other. For an internal fault the current at one end of the line reverses or remains below the fault detector setting so that carrier is sent only half of the time. The relay is arranged so that this produces tripping.

Figure 21 shows (heavy) the relative positions of the locally and remotely transmitted carrier pulses for internal

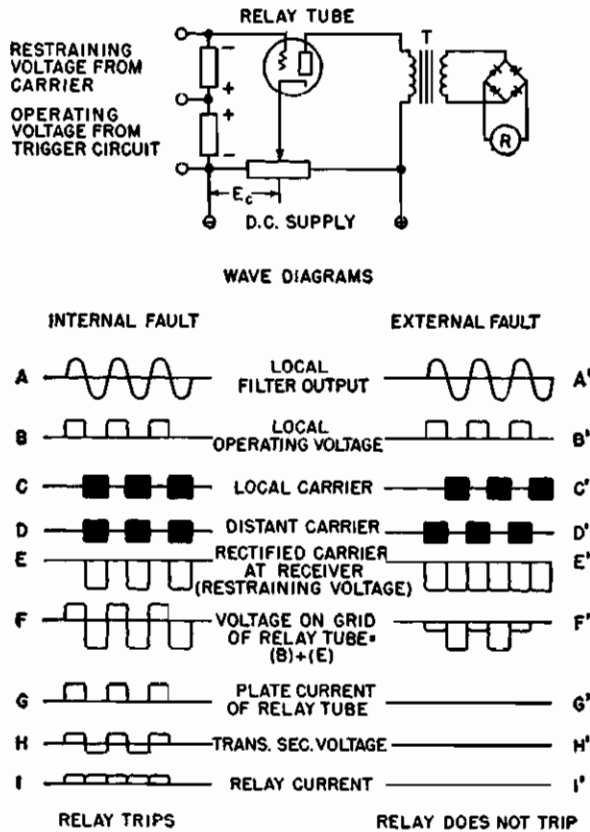

Fig. 21—Relay tube circuit and typical wave diagrams of type HKB carrier relaying system.

faults (left) and external faults (right). Local pulses of operating voltage are applied to the relay tube every half cycle. For the internal fault the pulses of restraining voltage caused by the carrier occur in the opposite half cycle from the operating pulses. Hence pulses of plate current occur and result in tripping. For the external fault, restraining pulses occur during both half cycles, and since these pulses are, by design, greater than the operating pulses, no trip current results. With the entering and leaving line currents not quite in phase, some relay current flows. However, as shown in Fig. 22, a substantial phase difference can be tolerated without causing tripping.

In this system, the carrier portion is purely pilot protection. Back-up protection must be added as an entirely separate entity. Stepped-distance relays, or simply directional-overcurrent relays, are used for back-up protection.

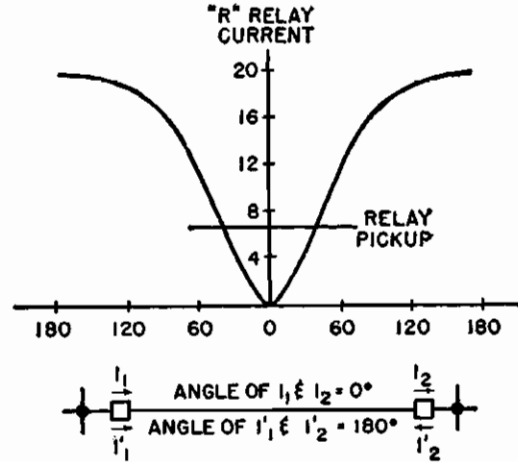

Fig. 22—Typical overall characteristics of the Type HKB carrier relaying system.

A few of the factors considered in determining whether to use one or the other of these systems are the following:

Favoring the Phase Comparison System

1. Can be added for high-speed protection with any existing relay scheme for back-up.
2. No potential transformers are required. Low-tension potentials are sometimes adequate for back-up relays.
3. Inherently trip proof on out-of-step conditions. (Out-of-step blocking relays are included in the other scheme if needed.)
4. Not subject to trip by induced ground current from a parallel line.
5. Back-up relays entirely separate. Can take either high-speed or back-up out of service without affecting the other.

Favoring the Directional-Comparison System Using Stepped-Distance Relays

1. More generally, applicable to multi-terminal lines.
2. Provides better discrimination between loads (tapped from lines) and faults. When transformers are tapped along the lines, it is not desired to trip the line for faults on the low-tension feeders.
3. Can trip with fault currents less than twice load currents.
4. More flexible for system changes.

However, on many lines either system is entirely applicable and might equally well be used.

Fig. 20 shows the complete equipment required for a carrier current relay system. Relays shown are of the directional-comparison type. The carrier components are the same with the phase-comparison type relays.

(a) The relays; practically the same as for high-speed distance-type protection except with the addition of the receiver relay, directional auxiliary relays, and out-of-step elements which are housed together. The Type HZ relay is shown in Fig. 23.

(b) The carrier current transmitter-receivers operated from the station battery and with an output of 5 to 40 watts at 50 to 150 kilocycles when keyed. The outdoor set contains line-tuning equipment for matching through the coupling capacitor to the high tension line. When the set is located indoors it is connected by coaxial cable to the line tuning equipment in a separate housing located near the coupling capacitor.

(c) The coupling capacitor. The connections to ground, and to the potential device if used, are through radio-frequency

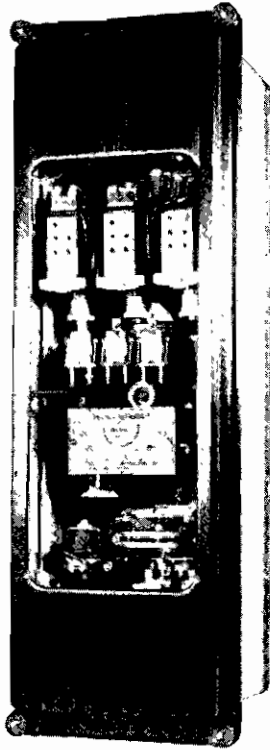

Fig. 23—The Type HZ high-speed, three-zone impedance relay. The relay is arranged for use either as a conventional step-type distance relay for phase-fault protection, or in the directional comparison scheme of pilot-wire or carrier-current relaying.

chokes. Thus, at carrier frequency, the coupling capacitor is simply a series capacitor between the carrier set and the high-tension line.

(d) The tuned carrier-current choke or wave trap, of sufficient capacity to carry the line current but imposing a high impedance to carrier current of the frequency used. Its purpose is to prevent loss of the carrier energy into other sections, so that ample signal strength is available in the protected section.

Microwave Relaying—Either the directional-comparison or phase-comparison systems of relaying can be used over microwave channels as well as power-line carrier channels without significant alteration. However, because the microwave channel is not subjected to line faults it does not necessarily have to be used in a blocking manner, but is suitable also for transfer tripping.

14. Pilot-Wire Relaying

Pilot wire relaying is to the short transmission line what carrier current protection is to the long one. It provides uniform simultaneous tripping of the circuit breakers at both ends of a section, with all that such operation implies in the way of increased stability, lessened shock and damage to the system, and simplified coordination with other relay protection. In short high-voltage lines, discrimination is often impossible with distance type relays; pilot relaying by wire or carrier becomes the only method of discrimination not based on time delays.

The cost of carrier-current protection is practically unaffected by the length of the line. The terminal equipment,

including the relays, carrier set, coupling capacitor, choke and installation, costs considerably more than the terminal equipment required with pilot-wire protection. However the cost of the pilot-wire circuit increases almost directly with the length of line; consequently there is an economic dividing line between carrier-current and pilot-wire applications. The average dividing line is at about 10 miles but it varies widely with such factors as: the availability of existing pilot-wire circuits, the number of other pilot wire services with which the cost of the pilot cable can be shared, the inductive exposure conditions which determine the test voltage of the pilot cable, and the cost and complexity of the necessary carrier-current channel.

The ideal pilot-wire relay systems should:

1. Require only two pilot wires.
2. Provide complete phase and ground protection with a single relay at each terminal.
3. Permit wide variations in current transformer performance.
4. Be suitable for use over leased telephone circuits.
5. Not operate incorrectly when the system is out-of-synchronism.
6. Provide adequate insulation between the pilot wires and the terminal equipment.
7. Have provisions for dealing readily with longitudinal induced voltages in the pilot circuits or with differences in station ground potential.
8. Have provision for supervising the pilot wires.
9. Operate at high speed.

A number of d-c or a-c pilot wire schemes based on directional comparison or on current differential have been used to a limited extent. For example an arrangement similar to the carrier-current protection described has been used with pilot wire. However by far the greatest number of pilot-wire relay applications employ the Type HCB relay thereby meeting all of the above requirements.

The arrangement is shown in Fig. 24. At each end of the line a voltage proportional to positive-sequence current

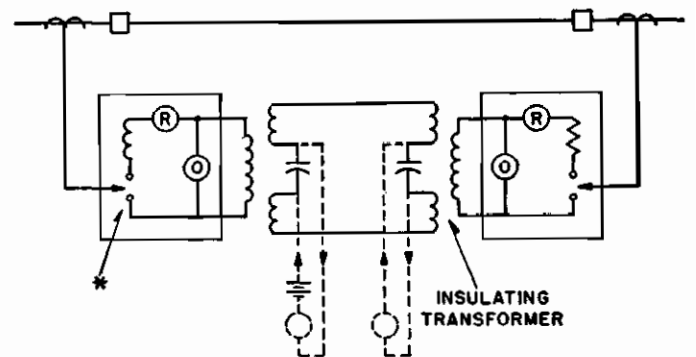

R = RESTRAINING COIL }
O = OPERATING COIL } D.C. RECTOX FED COILS ON A POLAR ELEMENT

*Positive-sequence and zero-sequence segregating network. The secondary currents are fed in. An internal voltage is produced proportional to $I_1 + KI_0$. The network as viewed from the relay element terminals has this internal voltage and an internal impedance. A saturating transformer, not shown, is used between the network and the relay element.

Fig. 24—Alternating current pilot wire scheme using the HCB relay. Simplified schematic. Only two wires are required and continuous supervision of them can be obtained as shown dotted.

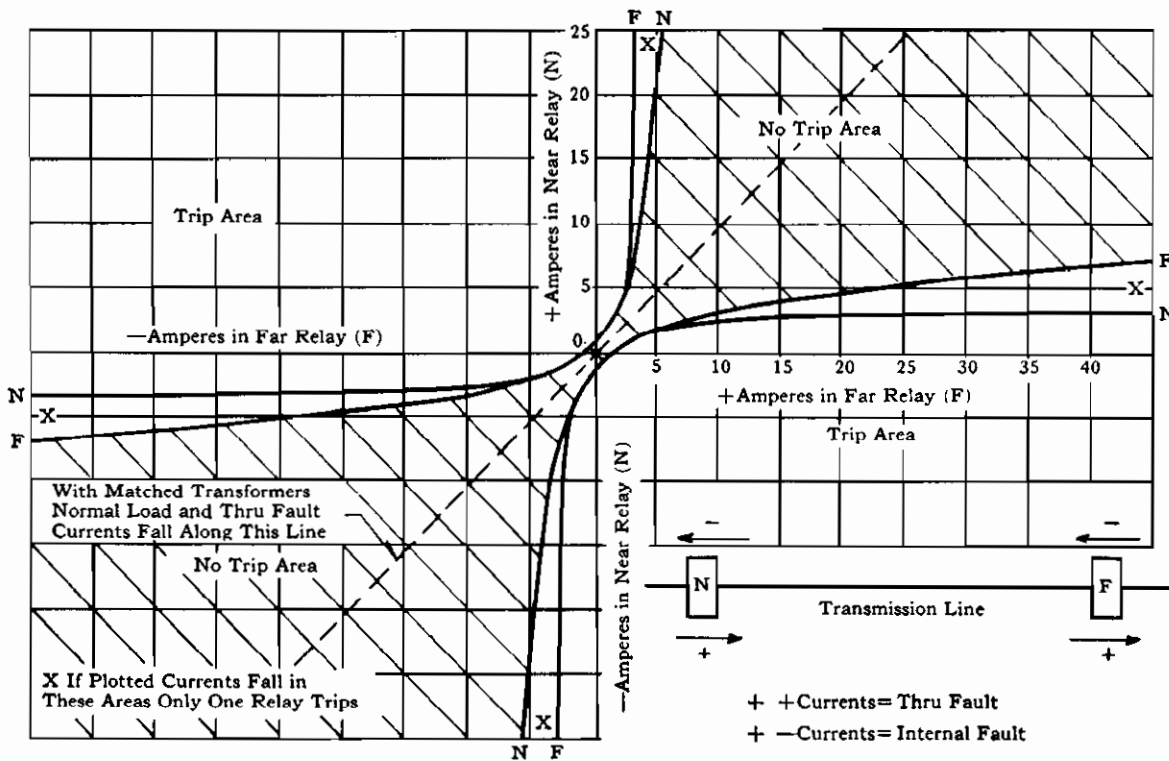

Fig. 25—Typical operating characteristics of the HCB relay for a phase A to ground fault with the currents through the two terminals 30 degrees out of phase, and a 2000-ohm pilot wire.

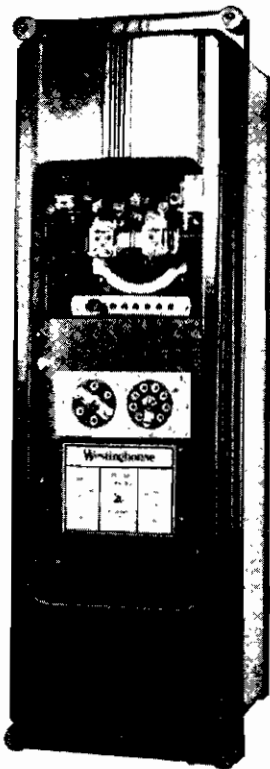

Fig. 26—The Type HCB pilot-wire relay. The relay has a single operating element, which functions for all types of phase and ground faults.

istics. Each relay contains a filter segregating the positive- and zero-sequence currents and combining the right amount of each into a single relaying quantity. Thus, by selecting the proper relay tap, tripping is obtained at any desired ground-fault current and phase-fault current. This reduction to a single differentiating quantity makes comparison over only two pilot wires possible. The ability to trip correctly even with badly mismatched current transformers is illustrated in Fig. 25. The vector positions of the sequence currents for various types of faults are illustrated in Fig. 32.

15. Ground Relaying

Overcurrent and directional relaying used for ground protection usually follows the same schemes as employed for phase protection. That is, the overcurrent ground relays for a radial system may be progressively timed, as in Fig. 13. For loop systems the directional element is added, polarized either by zero-sequence voltage or by a transformer bank neutral current which is proportional to zero-sequence voltage. This results in progressive timing as in the loop circuit of Fig. 12. Stepped-distance relaying is likewise used but with limitations which will be discussed.

There are a number of differences between ground and phase relaying.

(a) The zero-sequence impedance of the average transmission line is 2 to 5 times its positive-sequence impedance, while the zero-sequence impedance of the source, comprising frequently only the transformer-bank impedance, may be lower than the positive-sequence impedance of the source. Therefore as the fault is moved along the line, the

and a constant times the zero-sequence current is derived. The relay has variable-percentage differential character-

ground-fault current falls off more rapidly than the phase-fault current and current magnitude can be used more for discrimination, at least where ground wires are used.

(b) Usually there are many more sources of ground current than of phase current. This improves the selectivity obtainable with overcurrent ground relays.

(c) A system may have several unconnected portions of zero-sequence network, in which case a ground fault in one section does not draw ground current from other parts. This makes the coordination of ground relays simpler than that of phase relays.

(d) Fault resistance is likely to be much higher for ground faults than for phase faults on the higher voltage lines. At currents of 1000 amperes or more the arc voltage is 300 to 500 volts per foot so that a 1000-ampere line-to-line fault through a 5-foot arc involves a fault resistance of approximately 2500 volts divided by 1000 amperes or 2.5 ohms. Compared with this, pole grounds, which may be the fault impedance for a ground fault, are usually in the 5 to 50-ohm range. A wire on the ground can have almost any fault resistance. Being unaffected by load current, a ground-current relay can be set lower than a line-current relay. Thus it can be set low enough to operate even though the fault current is choked down considerably by fault resistance.

(e) The zero-sequence mutual reactance between two parallel lines is important, although positive-sequence mutual reactance is usually unimportant. The zero-sequence mutual reactance leads to circulating residual currents in one line for a fault in the other, even though the lines are part of two separate systems. It also interferes somewhat with distance-type ground relaying, although methods are available for compensating this effect in some cases.^{32,35}

Another factor of importance is that the fault, rather than the supply end of the line, is the source of zero-sequence voltage. That is, the zero-sequence voltage tapers down from the fault towards the relay as outlined in Sec. 23 and illustrated in Fig. 30.

These factors lead to difficulties in applying impedance or other distance measuring relays for protection against ground faults. While they have been used in some cases where conditions are favorable and where discrimination would be even more difficult by other means, their use is limited.

Overcurrent Ground Relaying—The vast majority of ground relaying is essentially overcurrent, with direction where needed. The more common elements follow:

Type CO—Induction-overcurrent relay with instantaneous-trip attachment. The instantaneous trip is set below the maximum ground current in the line for a fault at the next bus. Nonsimultaneous closure of the circuit breaker poles during load switching may result in momentary ground current sufficient to operate the instantaneous ground relays, where the relays are set sensitively. This has been avoided by connecting a residual-voltage-relay contact in series with the trip circuit. The latter does not operate during load switching operations.

As above but with induction-directional element, Fig. 2(e), controlling the induction overcurrent element. The directional element may be polarized either by residual voltage, Type CR, or bank-neutral current if available, Type CRC.

Instantaneous-overcurrent elements, such as the SC, can be

used if the line terminates at the far end in a transformer that will not pass residual current.

Reactance Relaying—has an inherent advantage over impedance relaying for ground fault protection in that the relay measurement is generally much less affected by fault resistance. If the currents supplied from the two ends of the line are not in phase, the fault resistance does appear to the relay to have some reactance. Nevertheless, the error in distance measurement caused by fault resistance is generally much less with a reactance element than with an impedance element.

For ground relaying it is desired that the relay measure the zero sequence reactance from the relay to the fault.³² It may be noted that the ratio of line-to-neutral voltage at the relay to zero-sequence current is:

$$\frac{E_a}{I_0} = \frac{I_0 Z_0 + I_1 Z_1 + I_2 Z_2}{I_0}$$

where I_0 , I_1 , I_2 are the sequence current at the relay and Z_0 , Z_1 , Z_2 the sequence impedances from relay to fault. Thus the zero sequence impedance can be measured as—

$$Z_0 = \frac{E_a - I_1 Z_1 - I_2 Z_2}{I_0} = \frac{I_0 Z_0}{I_0}$$

The positive and negative sequence voltage drops from relay to fault are deducted from the line to neutral voltage, E_a , by compensators and the resulting voltage divided by I_0 is a measure of the zero sequence impedance. A reactance element using this voltage and current will measure the zero sequence reactance as desired.

The type HXS ground reactance relay operates on this principle, three elements being used to provide stepped-distance protection. As there is zero-sequence current only for fault conditions, no separate fault detector is required. Only one HXS relay is used for all three phases, the voltage of the faulty phase being connected to it by a type HPS faulty-phase selector relay illustrated in Fig. 2(t).

To provide a single high-speed step, as for example where existing relays provide adequate backup protection, the HXL relay is used in conjunction with the HPS phase selector. This provides one ground reactance step, usually set about 75 percent of the line length, and a load-loss feature which opens the second breaker instantly after the first breaker opens. The load-loss feature utilizes three overcurrent elements to recognize by the closing of at least one back contact and one or more front contacts that a fault is present and the far breaker is open. Under normal load conditions all three front contacts are closed.

Negative-Sequence Directional Relaying—The negative-phase-sequence directional element can frequently be used to advantage with an overcurrent ground relay to obtain selective clearing of ground faults. This results from three facts—

1. Only two potential transformers are required.
2. On solidly-grounded systems the negative-phase-sequence voltage at the relay may be of larger magnitude than the zero-sequence voltage at that point, hence, a more positive relay operation can be obtained.
3. The negative-sequence directional element is not affected by zero-sequence mutual induction from parallel transmission circuits.

In some very important stations complete duplicate sets of relays are used, operated from separate transformers to provide the back-up function. Also in certain large generating stations, with double circuit breakers separating major bus sections with power concentrations of the order of 200 000-kw load, the back-up partial-differential circuit not only uses separate current transformers but trips the other circuit breaker of the double-breaker combination. The partial-differential protection can often be arranged so that it backs up generator, reactor, and bus protection as well as feeder protection.

Since carrier, pilot-wire or distance protection is sometimes required to obtain 100 percent selective primary protection, it is not always possible to obtain selective action of the back-up relays. There is some trend in the case of pilot-wire protection of short-line sections to cut the back-up relays in automatically when the supervision relays indicate that the pilot wires are inoperative. Some use is being made of carrier in a somewhat similar philosophy, to block certain back-up elements when carrier is being received.

17. Motor Protection

For the larger motors which are equipped with protective relays, the protection supplied varies with the importance of the service and whether automatic or not and whether attended or non-attended.

Many motors 500 horsepower and larger, and some smaller ones are protected by long-time (geared, 40-second) induction-type overcurrent relays set in the neighborhood of 150 percent of maximum-load current, but with timing to permit the starting inrush of several-hundred-percent current for several seconds. A typical case might be 600 percent for ten seconds for an across-the-line-started induction motor, although these figures vary widely, depending on the application, and must be determined in each individual case. These relays will operate for a stalled motor, for internal motor faults, or for a heavy overload.

The overcurrent relays are usually provided with instantaneous-trip attachments set above the motor-starting current to trip quickly for severe faults in starter, leads, or motor.

Thermal relays are frequently provided in addition to the overcurrent relays, to provide more sensitive overload protection. Having a time constant of several minutes as contrasted with seconds for the overcurrent relay, they follow the motor temperature more closely. They will not protect the motor under stalled conditions, however, where the motor ventilation is missing; the overcurrent relay provides this function.

In automatic applications, and where starting in reverse would be serious, a phase rotation relay is used which closes contacts to permit a starting only if the phase sequence is correct and voltage is present on all three phases. This does not guard against phase unbalances which might occur during operation, however. For this purpose, a phase-balance current relay, Fig. 2(p), is provided in many automatic schemes to trip if the 3-phase currents become excessively unbalanced. Time-delay under-voltage protection is frequently applied to guard against over-current or

process damage, resulting from sustained operation at low voltage. However, where continuous operation is more important than motor protection this feature is eliminated or used for alarm only.

Thermal-alarm devices applied directly on the motors are becoming increasingly popular in attended stations where the operator can determine from the ammeters or other indications, the source of trouble.

18. Power House Auxiliaries

The power house is the heart of any electric system and its functioning rests on the motors which drive its fans, pumps, gates, and other auxiliaries. Hence reliability is paramount, and in addition to provision of a most suitable power supply and spare units for certain auxiliaries, much attention has been given to the relay protection. A recent survey of United States practice* resulted in the following recommendations, attendance being assumed.

The 2300-volt motors should use long-time-delay phase-overcurrent relays for overload and internal motor faults, set at approximately 150 percent of rated current. They also should be equipped with instantaneous overcurrent relays for short-circuit protection set above maximum-inrush current. If the auxiliaries are transferred, the instantaneous relay must be set above a higher inrush current.

On essential motors* the time-delay overload relays may be used for alarm purposes only, and the instantaneous relays used to trip. In this case the time-delay relays can be set more sensitively than 150 percent of rated current.

Low voltage motors (208, 440, 550 volts) should use a thermal device for overload protection, and an instantaneous-trip device for short-circuit protection.

In addition, the report notes the desirability of eliminating undervoltage protection except for alarm purposes, so that the loss of auxiliaries due to system disturbances will be minimized.

19. Industrial Interconnections

When a line is tapped to an industrial plant having generation, it is common practice to segregate essential loads for operation from the plant generator and dump others in event of a line outage. If the same line is tapped for other plants, the problem arises of separating the plant under consideration from the line under conditions hazardous to its operation. One scheme in successful use on many industrial interconnections consists of separation based on any of three indications provided power flow has reversed and is toward the power company. The three indications are: under frequency, undervoltage, or generator overload. Any of these occurrences, provided power flow is away from the plant, is taken as sufficient cause for separating and at the same time dumping nonessential loads so that the remaining plant load may be brought within the capacity of the plant generation.

The relays normally employed are:

- Induction-type overcurrent for generator overload.
- Induction-type under-frequency relay.
- Induction-type undervoltage relay.
- High-speed-type three-phase directional relay.

The generator overload relay is directional controlled so

*Essential motors are in this case defined as those motors whose failure results in the shut-down of generating capacity.

that it will not start timing unless direction in the interconnection has reversed.

Directional relays are also used, without the voltage, frequency, or current fault detectors, for this purpose.

20. Three Terminal Lines

Lines having three or more terminals³⁸ are generally more difficult to protect than two-terminal lines. Alternating current pilot wire protection is applicable in many cases although the limiting values of pilot-wire capacitance and resistance are less per terminal than for two-terminal lines. Carrier schemes, particularly of the blocking type are applicable to multi-terminal lines. However, sequential operation of circuit breakers occurs if fault current of appreciable magnitude flows out at one terminal for an internal fault near another terminal. The first-zone impedance element nearest the fault, acting independent of carrier, opens the first circuit breaker, after which carrier is stopped by the directional elements permitting clearing of the other circuit breakers.

21. Out-of-Step Protection

Practically all utilities,⁹⁰ except those consisting of steam stations connected rigidly together electrically, have experienced system instability. Most utilities have experienced some undesired operation of fault-protective relays as a result of system instability. Quite a number of utilities attempt either to block line relays from tripping because of out-of-step conditions, or to set the relays so that tripping will occur at a preselected point. Out-of-step blocking in conjunction with carrier relaying is the method most commonly employed.

Synchronous frequency changers interconnecting two systems may suffer mechanical damage to shafts and couplings if permitted to operate with the systems out-of-step. The resulting power pulsations may be close to the natural frequency of the two-mass system composed of the two rotors with connecting shaft. Out-of-step relays are available which detect a slip cycle by the power reversal at high current and can be set to trip after two or three slip cycles, or before serious torque oscillations build up.

Quick clearing of faults by modern 8-, 5-, and 3-cycle circuit breakers and high-speed relays is well accepted as a measure of prime importance in improving system stability and reducing damage and permanent outages. Case after case could be cited where these improvements have been realized as circuit breakers and relays have been modernized up to present-day standards. High speed reclosing has been made possible by simultaneous operation of circuit breakers at the two ends of a transmission line by carrier-current or pilot-wire relaying. This measure is generally accepted as economically of greatest benefit in improving stability and service reliability. Three-pole⁹¹ reclosing has been most widely used. However, there are a number of applications of single pole reclosing⁹² which further enhance the stability by leaving the sound phases in service while the faulted ones are opened and reclosed.

22. Testing and Maintenance

Routine tests are made by many companies at quite frequent intervals such as one to three months, depending on

the importance of the service. However, the major calibration tests are generally scheduled for periods more of the order of six months to two years. One year is a quite common period. There is a decided feeling that too frequent testing may cause more harm from mistakes and inadvertent damage than the good that is accomplished. The tests vary from the over-all or primary test in which current is passed through the primary of the current transformer, and the circuit breaker tripped by the resulting relay action, to much less complete checks. A quite usual procedure would be to remove the relays from service and test and calibrate on a load box, and to check the instrument transformers for continuity and grounds. The instrument transformer-relay circuit is grounded at only one point⁹³ so that the intentional ground can be lifted for this test. If feasible the circuit breaker may be tripped by closing the relay contact.

23. Relaying Quantities and How They Are Obtained

The prime requisite of all protective relaying is a fundamental basis of discrimination, which has been variously referred to as a discriminating function or quantity, an operating principle, or a relaying quantity. This discriminating quantity must be one to which a protective relay can be made to respond, and one which separates the desired tripping values from the desired non-tripping values.

The common discriminating quantities, such as current, voltage, time, impedance, direction, and power are well known, and the methods of obtaining them from current transformers, potential transformers, and potential devices are generally understood and described elsewhere.^{1,32} No general treatment of this subject can be given here. However, some of the more important characteristics of these quantities will be briefly outlined. Some special consideration will be given the newer sequence quantities arising from the method of symmetrical components, given in Chap. 2.

Voltages and Currents During Fault Conditions—Ten different faults of four kinds can occur at one point on the system:

three-phase	ABC		
line-to-line	AB	BC	CA
double line-to-ground	ABG	BCG	CAG
single line-to-ground	AG	BG	CG

When one of these four kinds of faults occurs along the line, the voltage and current relations at the relay are somewhat as shown in Fig. 28. For a three-phase fault the currents are balanced and lag the line-to-neutral voltages by the impedance angle of the line. In an average high-voltage line this angle is about 60°. The addition of fault resistance tends to lower it. For line-to-line fault, say *BC*, the current in line *B* lags the collapsed *BC* voltage by a line impedance angle of about 60°. For a two-line-to-ground fault, for example *BCG*, a similar situation pertains, except that the line-to-neutral voltages *B* and *C* also collapse to an extent depending on how solidly the system is grounded. Consider two easily visualized cases. If the system is

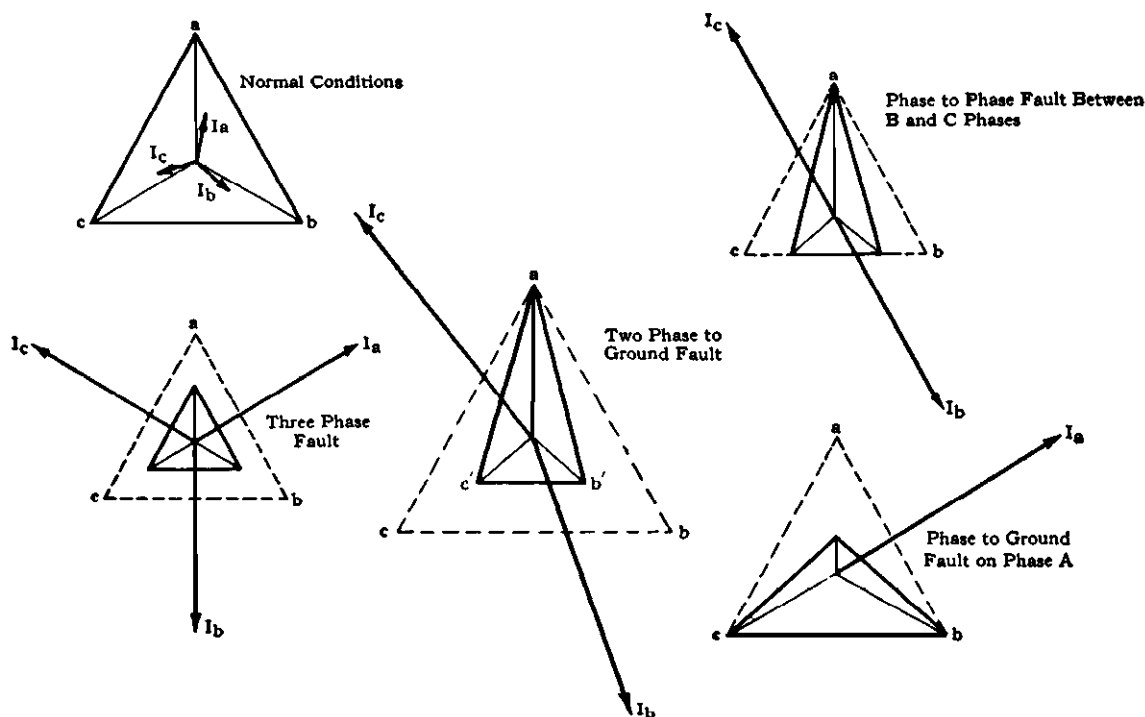

Fig. 28—Typical unbalanced conditions of current and voltage occurring during various types of fault on a three-phase system with an angle of sixty degrees. Load current flow neglected for fault conditions.

grounded through a very high impedance (Z_0 very high), the currents will be nearly the same as for a line-to-line fault except for a small added ground current. However, the fault will establish the mid-point between B and C phase voltages as ground potential. Another example is the case $Z_1 = Z_2 = Z_0$ for all parts of the system. For this case the phases are independent and the three-phase system acts exactly like three independent single-phase systems. The two-line-to-ground fault BCG , is the same as the three-phase fault except that phase A voltage is not collapsed, and only load current flows in phase A . The majority of systems fall between these two limits.

For a single line-to-ground fault on phase A , the corresponding line-to-neutral voltage collapses and the phase A current lags the line-to-neutral voltage of phase A by the impedance angle of the line-ground-return circuit including the fault impedance. If $Z_0 = Z_1 = Z_2$ throughout the system this fault will not influence the other two phases. If Z_0 is higher than Z_1 , corresponding to high impedance grounding, the condition of ungrounded operation or full displacement of the voltage triangle is approached.

Single-Phase Directional Element Response— Considering the different kinds of faults, and also their occurrence with symmetry to A , B , or C phases, the angle between voltage and current for a fault on the line varies over rather wide limits. In using a single-phase directional element, as in the CR , CZ , or HZ relay, a particular voltage must be associated with a particular current.

30° Connections. One of the common "connections" associates the phase A current with the phase CA voltage and is known as the 30° connection, because at unity power factor under balanced three-phase conditions the current leads the voltage by 30°. A watt-type* directional element

closes for current from approximately 90° ahead to 90° behind the voltage applied to its potential coils. For a three-phase fault on a 60° impedance-angle line the current lags behind its unity power factor position by 60°. With a 30° connection it lags the reference or polarizing voltage used on the directional element by 30°. Fault resistance (plus any modification of the relay characteristics by lagging) brings the fault current nearly to the maximum torque position. For the other kinds of faults on different phases the current is shifted one way or the other, but the wide closing band of the relay allows for this variation. The 30° connection uses star currents and delta voltages.

The same system is followed in naming other connections, although the relay used, including its phase-shifter if any, does not always have a closing zone for current from -90° to $+90^\circ$ with respect to voltage.

The 60° Connection uses delta currents and voltages; the $I_A - I_B$ current being used with the phase CA voltage. A relay with a closing zone approximately $+90^\circ$ to -90° is used. Delta-connected main or auxiliary current transformers are needed to obtain the delta currents.

The 90° Connection uses star currents and delta voltages; the phase A current being used with the phase CB voltage. In this case, however, a 45° voltage advancing phase-shifter is employed with the relay element giving it for star currents a closing zone approximately from 135° ahead to 45° behind the delta voltage. For a three-phase fault on a 60° impedance-angle line the phase A current leads the

*Other directional elements may have their closing zone shifted as much as 45° in the leading or lagging direction. The element used with the 30° connection may be a watt type or may have its closing zone shifted 10° to 20° in the lagging direction.

phase CB voltage by 30°, and a small fault resistance would swing it toward 45° leading. The closing zone extends 90° either side of this position and affords optimum opportunity for the relay to give correct directional indication with other kinds of faults.

Usually any of these three connections gives correct directional indication although in individual cases advantages can be found for one or the other, depending on such factors as the impedance angle of the line, the possible fault impedance, and the likelihood of an undesired amount of directional element operation caused by leading load currents near the directional boundary. For distance carrier relaying using single-phase directional elements the 60° connection using delta currents is preferred since the same delta current is used on the impedance element. If

TABLE 4—SEQUENCE POWER RESPONSE OF THREE-PHASE DIRECTIONAL ELEMENTS

VOLTAGE **	CURRENT **	CONNECTION	TORQUE VECTORS FOR PURE RESISTANCE SEE NOTE			NEEDED VOLTAGE SHIFT FOR 60° SYSTEM	RELATIVE THREE-PHASE TORQUE SEE NOTE
			POS. SEQ.	NEG. SEQ.	ZERO SEQ.		
STAR	STAR						
A	A	0°	→	←	←	-60°	P+N+Z
A	-B	60°	↘	↙	→	0°	$P\angle-60^\circ+N\angle+60^\circ-Z$
A	C	120°	↘	↙	→	+60°	$P\angle-120^\circ+N\angle-120^\circ+Z$
A	-A	180°	→	←	→	120°	-P -N -Z
A	B	240°	↘	↙	→	180°	$P\angle-240^\circ+N\angle-120^\circ+Z$
A	-C	300°	↘	↙	→	240°	$P\angle+60^\circ+N\angle-60^\circ-Z$
DELTA	STAR						
CA	A	*30°	↘	↙	NONE	-30°	$P\angle-30^\circ+N\angle+30^\circ$
CA	-B	*90°	↘	↙	NONE	30°	$(P-N)\angle-90^\circ$
CA	C	150°	↘	↙	NONE	90°	$P\angle-150^\circ+N\angle-210^\circ$
CA	-A	210°	↘	↙	NONE	150°	$P\angle-210^\circ+N\angle-150^\circ$
CA	B	270°	↘	↙	NONE	210°	$P\angle+90^\circ+N\angle-90^\circ$
CA	-C	330°	↘	↙	NONE	-90°	$P\angle+30^\circ+N\angle-30^\circ$
DELTA	DELTA						
CA	-C+A	0°	→	←	NONE	-60°	P+N
CA	A-B	*60°	↘	↙	NONE	0°	$P\angle-60^\circ+N\angle+60^\circ$
CA	-B+C	120°	↘	↙	NONE	60°	$P\angle-120^\circ+N\angle+120^\circ$
CA	C-A	180°	→	←	NONE	120°	-P -N
CA	A+B	240°	↘	↙	NONE	180°	$P\angle+120^\circ+N\angle-120^\circ$
CA	B-C	300°	↘	↙	NONE	240°	$P\angle+60^\circ+N\angle-60^\circ$
UNSYMMETRICAL CONNECTIONS							
(BA)	A	(3)	→	←	(4)	-60°	$P+N-\alpha^2 I_0 E_1 - \alpha I_0 E_2$
(BC)	C	(2)	→	←	NONE	-60°	P+N
(BA)	A-I ₀	(2)	→	←	NONE	-60°	P+N
(BC)	C-I ₀	(2)	→	←	NONE	-60°	P+N
(CA)	A-I ₀	(2)	(4)	(4)	NONE		$-\alpha^2 I_1 E_2 - \alpha I_2 E_1$
(BA)	C-I ₀	(2)	(4)	(4)	NONE		$-\alpha^2 I_1 E_2 - \alpha I_2 E_1$
(CB)	A-C	(1)	↓	↓	NONE	+30°	$(P-N)\angle-90^\circ$
(CA)	B-C	(1)	↓	↓	NONE	+30°	$(P-N)\angle-90^\circ$

*These are the commonly used 30°, 60°, and 90° connections.
 **Other phases connected symmetrically in sequence A, B, C.
 (1) A new two-element 90° connection giving the desirable P-N torque.
 (2) Two-wattmeter connection with zero-sequence current removed by a filter.
 (3) Two-wattmeter connection.
 (4) Parasitic torques.
 Note: Torque is the real part of the expression in the last column. $P = E_1 I_1$; $N = E_2 I_2$; $Z = E_0 I_0$. If the system were pure resistance throughout all E's and I's would be in phase, or phase opposition. For faults, N and Z would be negative at the relay, and P positive, but all three power terms would be pure scalars. The arrows show the vector position (not magnitude) of the torque expressions for this idealized pure resistance system case, taking into account that the values of N and Z are negative as shown in Fig. 29. If instead of being pure resistance the system were pure 60° impedance angle throughout the effect would be to rotate all currents negatively 60°, leaving all voltages unchanged. As the power terms are of the form $E I$ this will rotate similarly all the P, N, and Z quantities and hence the torque vectors. The real components of these vectors are the torques. Hence conclusions can be drawn as to whether the torques associated with P, N, and Z are additive and how much voltage phase shift is needed for optimum condition on a system of given impedance angle.

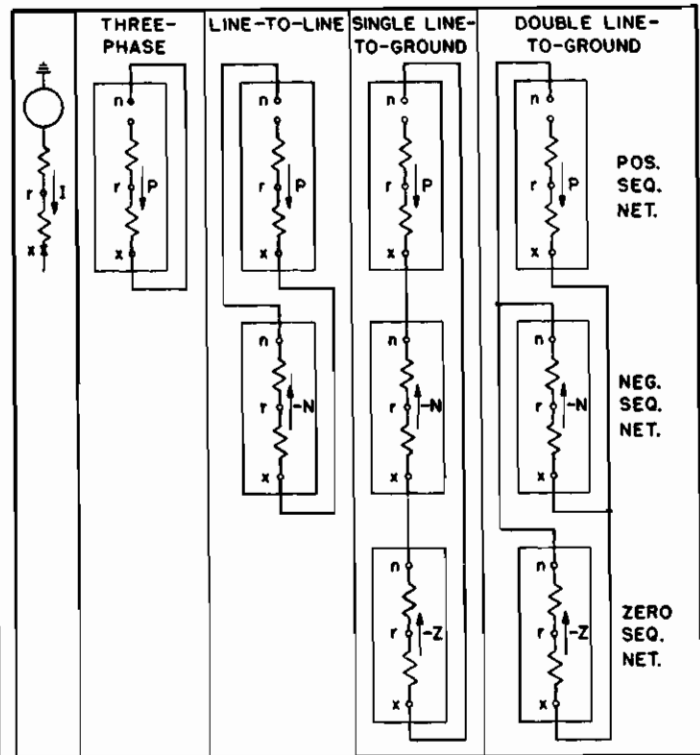

(a) ARROWS SHOW ACTUAL RELATIVE DIRECTIONS OF SEQUENCE POWER (VOLT-AMPERES AT SYSTEM IMPEDANCE PHASE ANGLE) FOR A SYSTEM OF THE SAME IMPEDANCE PHASE ANGLE THROUGHOUT.

P	LINE*	LINE* + NEG. SEQ. NETWORKS	LINE* + (NEG. & ZERO SEQ. NETWORKS)	LINE* + (PARALLEL OF NEG. & ZERO SEQ. NETWORKS)
N	NONE	SYSTEM*	SYSTEM*	SYSTEM*
Z	NONE	NONE	SYSTEM*	SYSTEM*

*Line refers to the line impedance from relay r to fault x of the particular sequence. System refers to the impedance from generator to r of the particular sequence.

(b) IMPEDANCE WHICH DETERMINES ANGLE OF POWER AT THE RELAY. (ANGLE OF SEQUENCE CURRENT BEHIND CORRESPONDING SEQUENCE VOLTAGE.)

Fig. 29—Diagrams showing the relative directions of positive-, negative- and zero-sequence power during fault conditions. The Chart (b) indicates what part of the system fixes the power factor for each sequence.

impedance element operation is caused by a line-to-ground fault its associated directional element is influenced by fault current. This overcomes any possible load current effect.

Three-Phase Directional Element Response—The same connections are used with three-phase directional elements*. In this case another factor influences selection of the connection. Table 4 shows the functions of sequence power to which various connections respond. As shown in Figs. 29 and 30, positive-sequence power flows toward the fault; negative- and zero-sequence power flows away from the fault, since the fault is the source of negative- and zero-sequence voltage. Therefore the positive-sequence

*This discussion relates to three independent single-phase elements on the same shaft. No three-phase rotating field is involved.

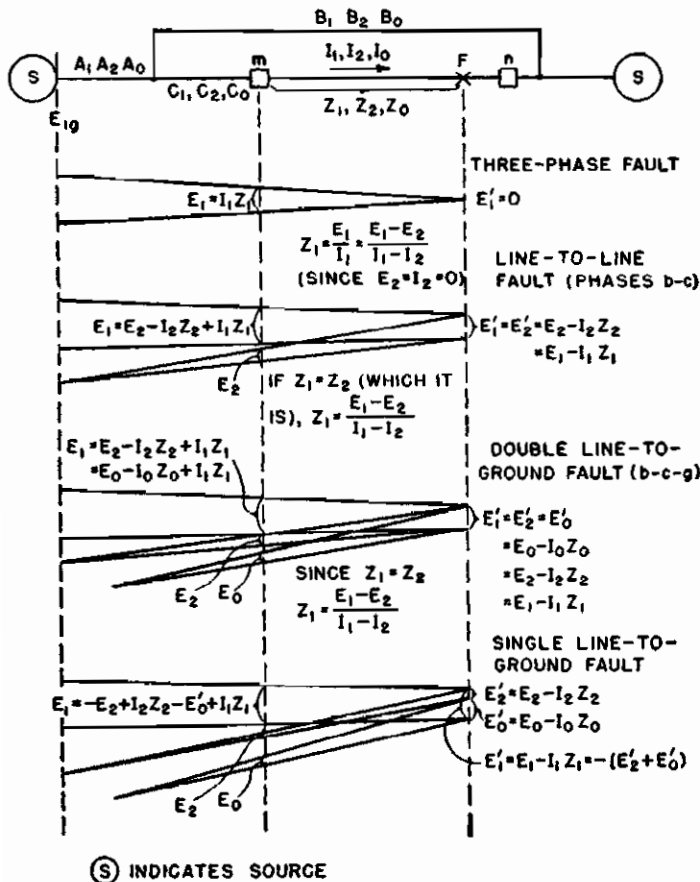

Fig. 30—Simplified equivalent system showing the sequence voltage distribution during fault conditions.

minus the negative-sequence power at the relay ($P-N$) is more positive for a fault out on the line than is ($P+N$), and hence provides a better fault directional indication, having higher torques for fault currents in relation to those due to load currents.

In table 4 the "connections" are shown in the first three columns, and the resulting three-phase torque on the element in the last column. The relative phase positions of the torques produced by positive- and negative-sequence power are shown in the 4th, 5th, and 6th columns, taking into account that when the impedance angles are the same throughout a system, the values of N and Z are opposite to P under fault conditions. The positive-sequence torque vector is drawn in the position of the conjugate of the current vector to produce maximum torque, the horizontal axis being the unity power factor position. Thus for the star-voltage, star-current, 0° connection maximum torque is for unity power factor. If a watt responsive element is used the voltage must be retarded 60° by a phase-shifter to obtain maximum torque for current lagging 60° .

The star-voltage, star-current, 60° connection* can be obtained with the phase A current associated with the negative of the phase B-to-neutral voltage, the other phases being symmetrically connected. This is perhaps the best star-current, star-voltage connection as no phase shift is required to get maximum positive-sequence torque with

*This is not the commonly referred to 60° connection.

current lagging 60° . Also the negative-sequence torque† is maximum for current lagging 120° and hence gives 50 percent of the maximum possible assistance to positive-sequence torque for 60° system-impedance angle. As the system-impedance angle is likely to be above 60° , this is quite favorable. The zero-sequence torque is also in the right direction though not maximum.

The delta-voltage, star-current, 30° connection has adverse negative-sequence torque, while the 90° connection is ideal in this respect, the positive- and negative-sequence torques have their maximums in the same direction for 90° lagging current. The usual 45° voltage-phase-shifter brings the maximum torque to a desirable point and maximum assistance is secured from the negative-sequence torque.

The delta-voltage, delta-current, 60° connection, like the corresponding star-star connection, has good negative-sequence torque in the proper direction for a 60° impedance-angle system. It has no zero-sequence torque. Maximum positive-sequence torque occurs for a 60° impedance angle without using a phase-shifter.

In addition to symmetrical connections, one unsymmetrical connection is worthy of note in that it is capable of securing the desirable $P-N$ accurately. It uses the B minus C current with the CA voltage and the A minus C current with the CB voltage. It has maximum torque for a 90° impedance-angle system and hence can be used to advantage with a 45° voltage advancing phase-shifter similarly to the better known 90° connection of three elements.

Impedance Measurement—Referring to Fig. 30, the difference between E_1 and E_2 at the relay is the positive-sequence drop from the relay to the fault plus the negative-sequence drop back to the relay. Recognizing that $Z_2 = Z_1$ for the line, it can be readily shown that the line impedance to the fault is:

$$Z_1 = \frac{E_1 - E_2}{I_1 - I_2} \tag{1}$$

This applies for three-phase, line-to-line, or double line-to-ground faults. For line-to-ground faults a higher impedance than Z_1 is measured by the ratio $(E_1 - E_2)/(I_1 - I_2)$. From Eq. (1) the delta connection is derived

$$I_b = I_0 + a^2 I_1 + a I_2 \tag{2}$$

$$I_c = I_0 + a I_1 + a^2 I_2 \tag{3}$$

$$I_b - I_c = (a^2 - a)(I_1 - I_2) \tag{4}$$

$$E_b - E_c = (a^2 - a)(E_1 - E_2) \tag{5}$$

$$\frac{E_b - E_c}{I_b - I_c} = \frac{E_1 - E_2}{I_1 - I_2} = Z_1 \tag{6}$$

The last expression shows that for fault at a given location the delta voltage divided by the delta current is the line impedance Z_1 for three-phase, line-to-line and double line-to-ground faults. As shown previously a higher value is measured for line-to-ground faults.

Lewis and Tippett³² give the fundamental basis for distance relaying in the most comprehensive paper on this subject. Among other things it is brought out that use of delta current and delta voltage on the impedance element, for example the A minus B current with the BA voltage, as

†This refers to torque due to negative-sequence currents and voltages. Actually it is torque in the positive direction.

outlined in the preceding paragraph, avoids a 15 percent difference in distance measured for line-to-line and three-phase faults, which is present if only one line current (star current) is used.

Use of Sequence Quantities*—In using sequence quantities the point of view should be developed, first, that the fault is the source of negative- and zero-sequence voltage and power, and that negative- and zero-sequence power (volt-amperes at system impedance angle) flow away from the fault at the relay location; second, that the sequence voltage is measured with respect to the bus-of-no-voltage or point *n* in the particular sequence network considered. These relations are brought out in Figs. 29 and 30.

Sequence Voltage Distribution During Faults—In Fig. 30 the voltage gradients are shown very generally. For a three-phase fault the voltage tapers off from the generator to the fault. For a line-to-line fault the positive-sequence voltage tapers off until, at the point of fault, it equals the negative-sequence voltage, which in turn tapers to zero back at the generator neutral, or point back of which there is no impedance to negative-sequence current. In some cases this may be an infinite bus.

For a double line-to-ground fault the positive-sequence voltage again tapers off to the point of fault where it equals the negative- and zero-sequence voltages. These taper to zero in going back through the network until a point of no voltage of the respective sequence is reached.

At a line-to-ground fault the positive-sequence voltage is the negative of the sum of the negative- and zero-sequence voltages and these taper to zero back through the network.

It is well to note that if the zero-sequence impedance is high (high-impedance grounded system), the zero-sequence voltage is nearly equal to the normal positive-sequence or line-to-neutral voltage for a line-to-ground fault, and approximately half as much for a double-line-to-ground fault where the generated voltage divides between the positive- and negative-sequence networks, thereby applying about half voltage to the zero-sequence network. As a result on lightly grounded systems all zero-sequence and residual voltages and currents are approximately half as much for double-line-to-ground as for line-to-ground faults.

Sequence-Segregating Filters—Sequence currents and voltages may be segregated from the corresponding line currents and voltages by segregating networks or filters. The methods of obtaining zero-sequence currents or voltages are already well known as these quantities are simply one-third of the corresponding residual quantities. Typical sequence-segregating networks are given in Fig. 31. The performance of each network is expressed by giving its equivalent circuit¹¹² and also by giving the equations of operation.

Polyphase networks for segregating positive- and negative-sequence voltage are shown in parts (a) and (b), and are useful for operating a polyphase device in response to either of these quantities. The positive-sequence filter is also useful for obtaining a balanced three-phase supply from an unbalanced (or single-phase) supply. The remaining filters shown all have single-phase output.

Parts (c) and (d) are auto-transformer type voltage-segregating networks and parts (e) and (f) are the all-im-

*Refer to Chapt. 2.

pedance type and require a special potential transformer connection. The star series transformer connection for obtaining zero-sequence voltage is shown in part (g). Parts (h) and (i) are three-winding-reactor type current filters whereas parts (j) and (k) use an auxiliary current transformer to produce the reactive drop due to *B* minus *C* current in a single-winding reactor. Note: The Type CRS negative-sequence directional relay uses filters (d) and (i) for negative-sequence voltage and current respectively.

Parts (l), (m), (n), and (o) are all impedance-type current filters, (l) and (m) being suitable only when there is no zero-sequence current; (n) and (o) are not affected by zero-sequence current, but require double the number of current transformers.

Part (p) is a zero-sequence current filter, which is merely the neutral connection of star-connected current transformers.

A combination positive- and zero-sequence current-segregating filter is illustrated in part (q). This filter is used in the Type HCB pilot-wire relay.⁶² The relative weighting of zero and positive sequence is determined by the relative magnitude of R_0 and R_1 . For example, if it is desired that the same internal voltage E_i be produced by one-tenth as much zero-sequence current as positive-sequence current, the zero-sequence weighting factor k must be set equal to 10. Then the required value of R_0 may be determined as follows:

$$R_0 = \frac{2}{3}kR_1 = 6.67R_1$$

The relative phase positions and magnitudes of various sequence quantities of the reference or A phase vary with the type and phase of the fault. The response of a combination filter varies accordingly. Fig. 32 illustrates the relative positions and magnitudes of the vectors comprising the quantity $I_1 + kI_0$ on a system for which the ground-fault current is one-tenth of the phase-fault current, and using a zero-sequence weighting factor of $k = 15$. The I_1 vectors have been magnified somewhat in the line-to-ground fault diagram to make them visible; their actual

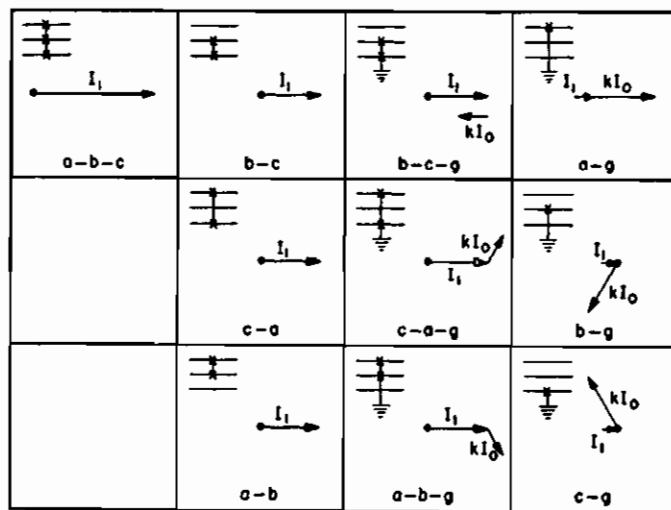

Fig. 32—Vectors comprising the relaying quantity $I_1 + KI_0$ shown for $K = +15$. I_1 vectors magnified in line-to-ground fault cases.

Same as (h) except with *b* and *c* leads crossed as shown dotted

$$I_x = \frac{2RI_2}{R+Z+Z} \quad E_1 = 2RI_2$$

$$E_{xy} = \frac{2ZRI_2}{R+Z+Z}$$

(i) Negative-sequence-current segregating filter and relay

ACTUAL CIRCUIT

EQUIVALENT CIRCUIT

(j) Positive-sequence-current segregating filter

$$I_x = \frac{2R}{Z+Z'} I_1$$

$$E_{xy} = Z' I_x = \frac{2RZ'}{Z+Z'} I_1$$

$$E_1 = 2RI_1$$

$$Z^* = R + jR/\sqrt{3}$$

Same as (i) except *b* and *c* leads crossed as shown dotted

$$I_x = \frac{2R}{Z+Z'} I_2$$

$$E_{xy} = Z' I_x = \frac{2RZ'}{Z+Z'} I_2$$

$$E_1 = 2RI_2$$

$$Z^* = R + jR/\sqrt{3}$$

(k) Negative-sequence-current segregating filter

$$I_x = \frac{j\sqrt{3}R}{Z+Z'} I_1$$

$$E_{xy} = Z' I_x = \frac{j\sqrt{3}RZ'}{Z+Z'} I_1$$

$$E_1 = j\sqrt{3}RI_1$$

$$Z^* = \sqrt{3}R e^{j30^\circ} = 1.5R + j0.866R$$

When *R* is pure resistance, then *r* = 0.5*R* and *X* = 0.866*R*

(l) Pos.-seq.-current segregating filter. For use only where there is no zero sequence.

$$I_x = \frac{\sqrt{3}R e^{-j30^\circ}}{Z+Z'} I_2$$

$$E_{xy} = Z' I_x = \frac{\sqrt{3}R e^{-j30^\circ} Z'}{Z+Z'} I_2$$

$$E_1 = \sqrt{3}R e^{-j30^\circ} I_2$$

$$Z^* = \sqrt{3}R e^{j30^\circ} = 1.5R + j0.866R$$

If *R* is pure resistance, then *r* = 0.5*R* and *X* = 0.866*R*

ACTUAL CIRCUIT

EQUIVALENT CIRCUIT

(m) Neg.-seq.-current segregating filter. For use only where there is no zero seq.

$$I_x = \frac{-3R}{Z+Z'} I_1$$

$$E_{xy} = Z' I_x = \frac{-3RZ'}{Z+Z'} I_1$$

$$E_1 = -3RI_1$$

$$Z^* = \sqrt{3}R e^{j30^\circ} = 1.5R + j0.866R$$

If *R* is pure resistance, then *r* = 0.5*R* and *X* = 0.866*R*

(n) Positive-sequence-current segregating filter. With (or without) zero sequence.

ACTUAL CIRCUIT

EQUIVALENT CIRCUIT

(a) Polyphase positive-sequence-voltage segregating filter

$$I_x = I_{1x} = \frac{E_1 e^{-j60^\circ}}{Z+Z'}$$

$$I_y = I_{1y} = a^2 I_{1x}$$

$$I_z = I_{1z} = a I_{1x}$$

$$I_{2x} = 0$$

$$E_x = E_{1x} = \frac{Z}{Z+Z'} E_1 e^{-j60^\circ}$$

$$E_y = E_{1y} = a^2 E_{1x}$$

$$E_z = E_{1z} = a E_{1x}$$

$$E_{2x} = 0$$

$$Z = \frac{R e^{j30^\circ}}{\sqrt{3}}$$

If *R* is a pure resistance, then: *r* = 0.5*R* and *X* = 0.866*R*.

ACTUAL CIRCUIT

EQUIVALENT CIRCUIT

(b) Polyphase negative-sequence-voltage segregating filter (Same as positive-sequence filter except for interchange of *b* and *c* leads)

$$I_x = I_{2x} = \frac{E_2 e^{-j60^\circ}}{Z+Z'}$$

$$I_y = I_{2y} = a I_{2x}$$

$$I_z = I_{2z} = a^2 I_{2x}$$

$$I_{1x} = 0$$

$$E_x = E_{2x} = \frac{Z E_2 e^{-j60^\circ}}{Z+Z'}$$

$$E_y = E_{2y} = a E_{2x}$$

$$E_z = E_{2z} = a^2 E_{2x}$$

$$Z = \frac{R e^{j30^\circ}}{\sqrt{3}}$$

If *R* is pure resistance, then: *r* = 0.5*R* and *X* = 0.866*R*.

ACTUAL CIRCUIT

EQUIVALENT CIRCUIT

(c) Positive-sequence-voltage segregating filter

$$I_x = \frac{E_1}{N} \frac{1.5 e^{-j60^\circ}}{Z+Z'}$$

$$E_{xy} = I_x Z' = 1.5 e^{-j60^\circ} \frac{Z'}{Z+Z'} \frac{E_1}{N}$$

$$E_1 = \frac{1.5 e^{-j60^\circ}}{N} E_1$$

$$Z^* = \frac{(3R + j\sqrt{3}R)}{4}$$

(d) Negative-sequence-voltage segregating filter

$$I_x = \frac{E_2}{N} \frac{1.5 e^{-j60^\circ}}{Z+Z'}$$

$$E_{xy} = I_x Z' = 1.5 e^{-j60^\circ} \frac{Z'}{Z+Z'} \frac{E_2}{N}$$

$$E_1 = \frac{1.5 e^{-j60^\circ}}{N} E_2$$

$$Z^* = \frac{(3R + j\sqrt{3}R)}{4}$$

ACTUAL CIRCUIT

EQUIVALENT CIRCUIT

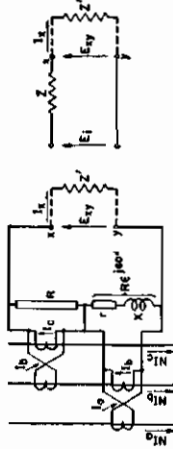

(o) Negative-sequence-current segregating filter. For use when zero-sequence current is (or is not) present.

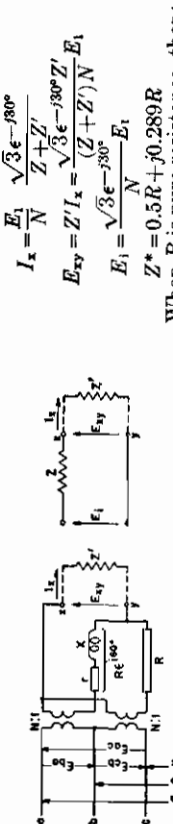

(c) Positive-sequence-voltage segregating filter

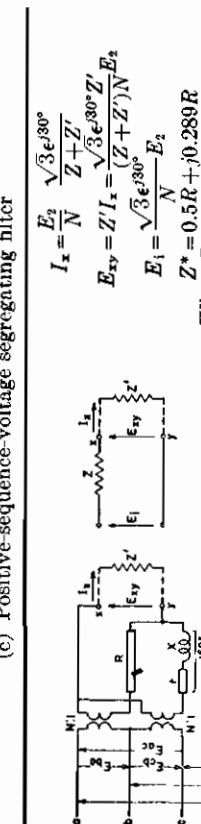
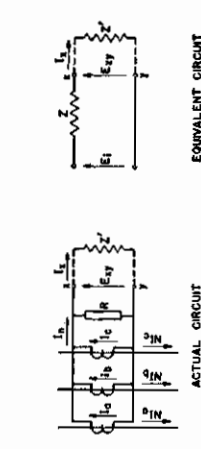

(p) Zero-seq.-current segregating filter (Neutral or star-connected current transformers)

(f) Negative-sequence-voltage segregating filter

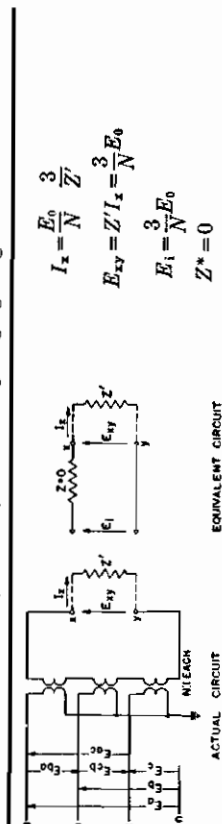
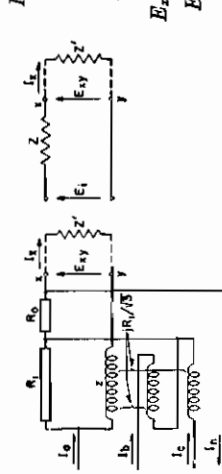

(q) Combined pos-seq.-current and weighted zero-seq.-current segregating filter

(g) Zero-seq.-voltage segregating filter (otherwise called star-series transformer connection)

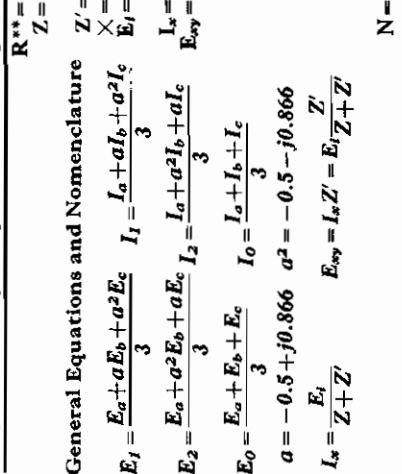

(h) Positive-sequence-current segregating filter and relay

$$I_x = \frac{3R e^{-j120^\circ}}{Z + Z'} I_a$$

$$E_{xy} = Z' I_x = \frac{3R e^{-j120^\circ} Z'}{Z + Z'} I_a$$

$$E_1 = 3R e^{-j120^\circ} I_2$$

$$Z^* = \sqrt{3} R e^{j30^\circ}$$

If R is pure resistance, then:
 $r = 0.5R$ and $X = 0.866R$

$$I_x = \frac{3R}{R + Z'} I_0$$

$$E_{xy} = I_x Z' = \frac{3R Z'}{R + Z'} I_0$$

$$E_1 = 3I_0 R$$

$$I_x = 3I_0$$

$$E_{xy} = 3Z' I_0$$

$$R = \infty \Rightarrow E_1 = 3I_0$$

$$Z = \infty \Rightarrow Z' = 3I_0$$

Note: Residual or neutral current is three times the zero-sequence current. ($I_0 = 3I_0$)

$$I_x = -\frac{2R_1 I_1 + 3(R_0 + R_1/3) I_0}{Z + Z'}$$

$$k = \frac{3(R_0 + R_1/3)}{2R_1}$$

$$R_0 = \frac{2}{3} k R_1 - \frac{R_1}{3}$$

$$E_{xy} = I_x Z' = -\frac{2R_1 Z' (I_1 + k I_0)}{Z + Z'}$$

$$E_1 = -2R_1 I_1 - 3(R_0 + R_1/3) I_0$$

$$Z^* = R_1 + R_0 + z$$

$$z = \text{Self impedance of indicated winding of three-winding segregating filter}$$

$R^{**} =$ Reference impedance of filter.
 $Z =$ Impedance of equivalent circuit of filter.
 $Z' =$ Impedance of connected burden.
 $\times =$ Polarity marks.
 $E_1 =$ Internal voltage of equivalent circuit of filter.
 $I_x =$ Current in burden.
 $E_{xy} =$ Voltage at burden terminals, taking into account regulation in the filter. For maximum power output from a given filter make $Z' = Z$. For maximum power output from a given filter feeding into a pure resistance burden ($Z' = R$) make $R' = Z$.
 $N =$ Current transformer or potential transformer ratio as indicated.

General Equations and Nomenclature
 $E_f = \frac{E_a + aE_b + a^2E_c}{3}$ $I_1 = \frac{I_a + aI_b + a^2I_c}{3}$
 $E_2 = \frac{E_a + a^2E_b + aE_c}{3}$ $I_2 = \frac{I_a + a^2I_b + aI_c}{3}$
 $E_0 = \frac{E_a + E_b + E_c}{3}$ $I_0 = \frac{I_a + I_b + I_c}{3}$
 $a = -0.5 + j0.866$ $a^2 = -0.5 - j0.866$
 $I_x = \frac{E_1}{Z + Z'}$ $E_{xy} = I_x Z' = \frac{E_1 Z'}{Z + Z'}$

More generally Z is the impedance measured on the terminals x, y with the burden Z' disconnected and the applied voltages E_x, E_y, E_z set equal to zero (or applied currents I_x, I_y, I_z made zero by open circuiting corresponding leads in the case of current filters). This includes in the proper manner the impedances of the potential or auxiliary current transformers. The values of Z given above are based on the use of ideal potential and auxiliary current transformers having

zero leakage impedance and zero exciting current. The reference impedance of the filter may be any vector value or a pure resistance. The other filter impedances must take corresponding values as indicated by their defining equations. They are resistances and reactances as indicated by the symbols on the diagrams only when the reference impedance, R , is pure resistance.

Fig. 31—Typical sequence segregating networks.

(o) Negative-sequence-current segregating filter. For use when zero-sequence current is (or is not) present.

(c) Positive-sequence-voltage segregating filter

(p) Zero-seq.-current segregating filter (Neutral or star-connected current transformers)

(q) Combined pos-seq.-current and weighted zero-seq.-current segregating filter

(g) Zero-seq.-voltage segregating filter (otherwise called star-series transformer connection)

(h) Positive-sequence-current segregating filter and relay

Fig. 31—Typical sequence segregating networks.

length being one-fifteenth of the kI_0 vector. The combination, I_1+kI_0 , is the discriminating quantity used in the Type HCB pilot-wire relay which in effect totalizes the two ends of the circuit. It is a single quantity having, for a majority of systems, a much greater value for fault conditions than for load conditions and thus is an ideal discriminating quantity.

24. Reclosing

Many of the faults occurring on power systems are transient in nature and if the circuit is opened momentarily, permitting the arc to become extinguished, the circuit can be reclosed successfully. The necessary power-off time for deionization of the arc is given in Chapt. 13. For example, Logan and Miles⁸⁸ have found that on the Georgia power system the number of successful reclosures is as follows.

Number of trip-outs.....	10090	100%
Successful reclosures		
1st immediate.....	8400	83.25%
2nd 15-45 seconds.....	1084	10.05%
3rd 120 seconds.....	143	1.42%
Circuit lockouts.....	553	5.28%

This knowledge is used in a variety of ways. Many radial distribution feeders are provided with reclosing relays. A very common arrangement, using the Type RC reclosing relay shown in Fig. 33, provides for one immediate and sev-

eral time-delay reclosures. In the event of a tripout after the third reclosure the line is locked out until the relay is reset manually. However if the line "holds," even on the third "try," the reclosing relay resets automatically, and is prepared to repeat the same performance at a later time.

For a feeder sectionalized by a number of fuses, the replacement of a fuse involves a service trip. However, an opening and reclosing operation interrupts the current before any fuses blow, and if the fault is transient, the service trip is avoided.

"Single-shot" reclosing which is also widely used may be accomplished by the Type SGR-12 reclosing relay. As shown by Logan's data, it takes care of the large proportion of cases. Also a self-reclosing single-pole circuit breaker is used principally on single-phase feeders to perform the single-shot reclosing function without the use of relays. Multiple-shot fuses are also used but require delayed action of subsequent fuses and necessitate refilling manually after each operation.

On tie lines or single lines serving important industrial loads reclosing is used for quite another purpose, namely, to keep the systems from going out-of-step or to prevent loss of essential loads. This phase of the problem is covered in Chapt. 13.

III. CONTROL SCHEMES

To secure the system benefits expected from the circuit breakers and protective relays, it is essential that the control scheme used result in prompt and reliable tripping of the circuit breaker when the relays indicate a fault within their protective zone. Two factors are involved: a reliable source of control power, and a scheme that permits the breaker to trip free in spite of all manual or automatic closing agencies.

A control battery provides the the most reliable source of tripping energy, and is connected to the shunt-trip coil by the protective relay contacts as shown in Fig. 34. As

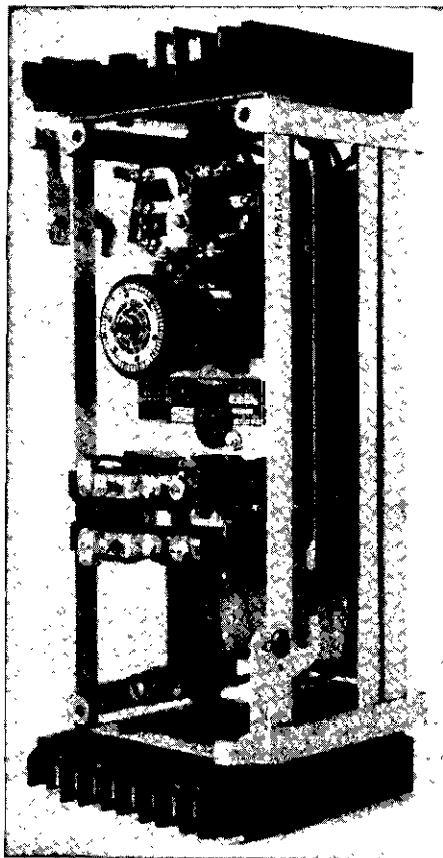

Fig. 33—The Type RC reclosing relay. A single instantaneous plus several time-delay reclosures can be initiated with this relay.

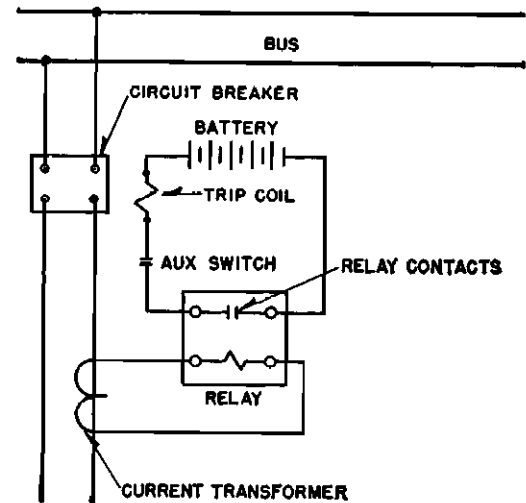

Fig. 34—A protective relay and circuit breaker. When the breaker opens, the auxiliary switch interrupts the trip circuit to prevent burning of the relay contacts.

the circuit breaker opens, the trip circuit is broken by an auxiliary switch linked to the circuit breaker.

25. Electrically Trip-Free Scheme

Fig. 35 shows a typical circuit-breaker control scheme, one of the several commonly used, known as the X-Y relay scheme. A station battery provides power for closing and

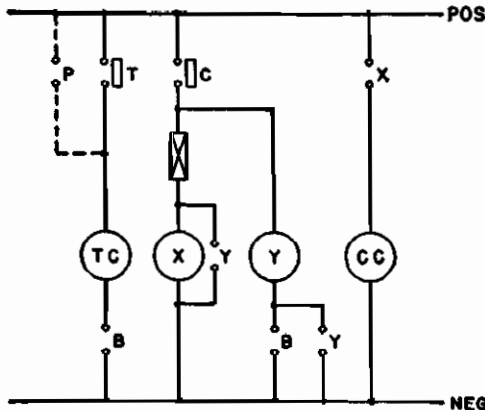

Fig. 35—The X-Y scheme of circuit breaker control using a battery.

- C—Closing contact of control switch.
- T—Tripping contact of control switch.
- X—Closing contactor or relay.
- CC—Closing coil of main circuit breaker.
- Y—Releasing contactor or relay.
- P—Typical protective relay contact.
- B—Auxiliary switch (closed when main circuit breaker is closed).
- TC—D-C shunt trip coil of main circuit breaker.

tripping. The control switch merely controls the application of battery power to the closing solenoid or shunt-trip coil as desired. The protective relay, when it operates, applies battery power to the shunt trip coil.

The X-Y relay scheme prevents pumping and makes the circuit breaker electrically trip-free. The closing contact of the control switch picks up the X relay that energizes the closing solenoid of the circuit breaker. As the circuit breaker reaches its closed position, an auxiliary switch B energizes the Y relay that seals in through its own front contacts. The Y relay contacts shunt the X relay, which opens and interrupts current to the circuit breaker closing solenoid.

If the circuit breaker trips automatically when it is closed in on a fault, it will open and will not reclose even though the operator holds the control switch in the closing position. The X relay remains shunted by the Y relay until the control switch is returned to the neutral position.

The trip-free relay scheme¹ provides a similar action through the use of a specially designed contactor for controlling the heavy current to the breaker-closing solenoid. The moving contact assembly of this contactor is tripped free from the operating armature by a release coil energized by an auxiliary switch when the circuit breaker reaches its closed position. Thus even though the closing contact of the control switch or of an automatic closing device remains closed, thereby holding the operating armature closed, the circuit to the closing solenoid of the circuit

breaker remains open after the circuit breaker has once closed in and tripped out. This situation continues until the control switch is restored to neutral or the closing contact of the automatic device opens.

26. Mechanically Trip-Free Arrangements

If a circuit breaker is to be closed manually against a possible fault, it should be mechanically trip-free from the closing linkage. The mechanically trip-free feature provides somewhat faster tripping for three reasons. First, the circuit breaker contacts can be tripped free anywhere in the closing stroke without waiting for the closing current to be cut off before acceleration towards the open position can start. Second, with the contacts tripped free from the closing solenoid the mass to be accelerated is less. Third, because of eddy currents the flux in the closing solenoid does not decay immediately when the circuit is opened; thus there is appreciable magnetic retardation in the opening of a mechanically non-trip-free breaker which has just been closed.

High-speed reclosing requires that the circuit breaker be mechanically non-trip-free so that the contact motion can be arrested before the full open position and the breaker closed again. To meet this need without encountering delayed opening if the reclosure takes place on a permanent

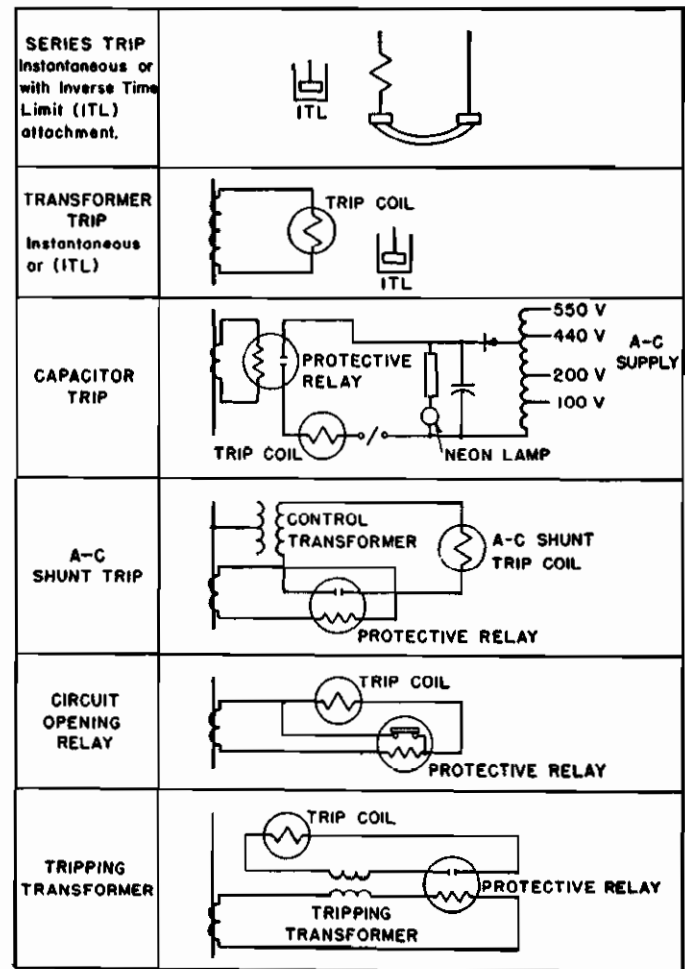

Fig. 36—A-C tripping schemes.

fault, a mechanism has been designed that is mechanically trip-free on the second opening but not on the first, except when the circuit breaker is initially closed.

27. A-C Tripping

In less important locations, where the cost and maintenance of a control battery is not justifiable, various forms of a-c tripping are employed for the smaller, lower voltage circuit breakers. Some of the more desirable of these are shown in Fig. 36.

The series-trip and transformer-trip schemes are used where the accurate magnitude and timing characteristics of a protective relay are not required. The transformer trip is used where the primary voltage or current is too great for the series trip.

The capacitor trip and a-c shunt trip require a source of a-c control power. The capacitor trip is much to be preferred in most cases because its ability to trip is not impaired by the momentary drop in voltage at the time of a fault. The a-c supply is taken from the source side of the circuit breaker so that the capacitor is charged before the circuit breaker is closed. A-c shunt tripping can be used only where the reduction of voltage at time of fault on the protected circuit will not prevent tripping by some tripping agency.

The circuit-opening relay scheme and the tripping-transformer scheme are similar to the transformer-trip scheme in that the line current transformer supplies the trip-coil energy. However, a protective relay is added and must be supplied by the same or by a different current transformer. The trip coil imposes a heavy burden on the current transformer, and there is a definite lower limit to the primary current at which tripping can be secured. The relay must, of course, be set above this value.

IV. APPLICATION OF CIRCUIT BREAKERS

The application of circuit breakers to power and lighting circuits involves the choice of the type of breaker and its mounting or housing as well as determination of the specific ratings required for the particular service.

28. Typical Circuit Breaker Construction and Practice

Low Voltage Circuit Breakers—Circuit breakers intended for service on a-c circuits up to 1500 volts and d-c circuits up to 3000 volts are classified as low-voltage breakers.¹⁰⁸ For such service air breakers have many advantages and are generally used in preference to oil breakers. They are inherently fast in operation, free from fire hazard, require little maintenance on repetitive service, and, because of the low voltage, are simpler, more compact, and easier to handle than oil breakers.

For low-capacity branch lighting and utility circuits such as are found in commercial and public buildings, small, molded case "thermal-breakers" are grouped in panelboards such as that shown in Fig. 37. Such breakers are usually operated manually and are available in ratings up to a maximum of 600 amperes load current and 25 000 amperes interrupting current. They provide automatic inverse-time overload tripping to protect circuit wiring

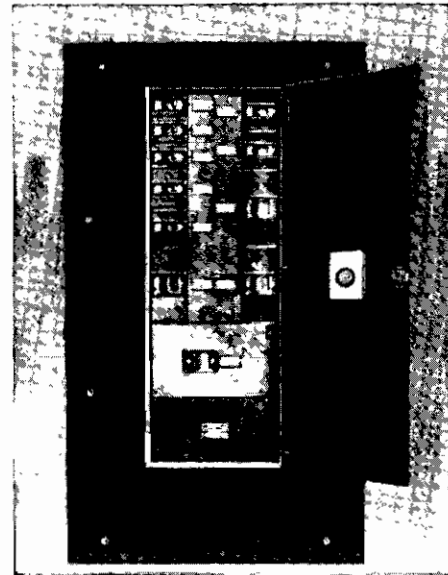

Fig. 37—Low-voltage distribution panelboard.

against overloads and short-circuits. Separate protective equipment is required for utilization devices such as motors.

For more important and higher capacity circuits, metal-enclosed, drawout assemblies of air circuit breakers, as in Figs. 38 and 39, are used. Typical applications are found in main feeders of the lighting and utility circuits described above, and for the low-voltage power circuits of such buildings as well as industrial plants and generating stations. These breakers may be operated either manually or electrically (under some conditions only electrical operation is recommended) and may be obtained with direct-acting series overload trips or relays which will give selec-

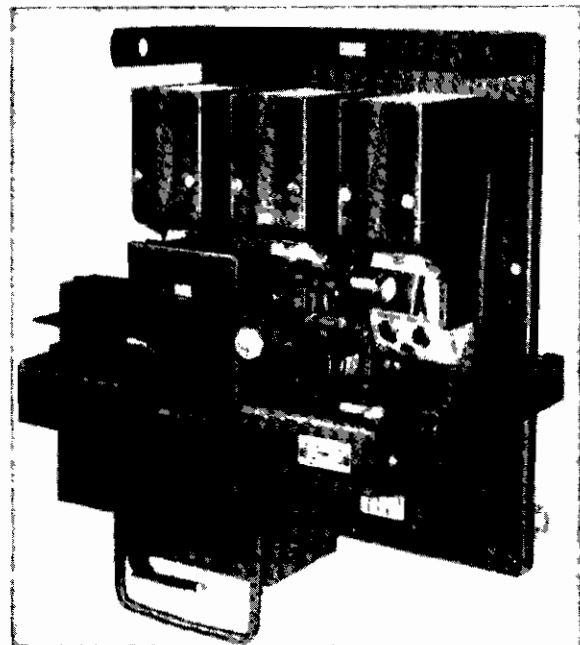

Fig. 38—1600 ampere, 600 volt, Type DB-50 air circuit breaker—50,000 amperes interrupting capacity.

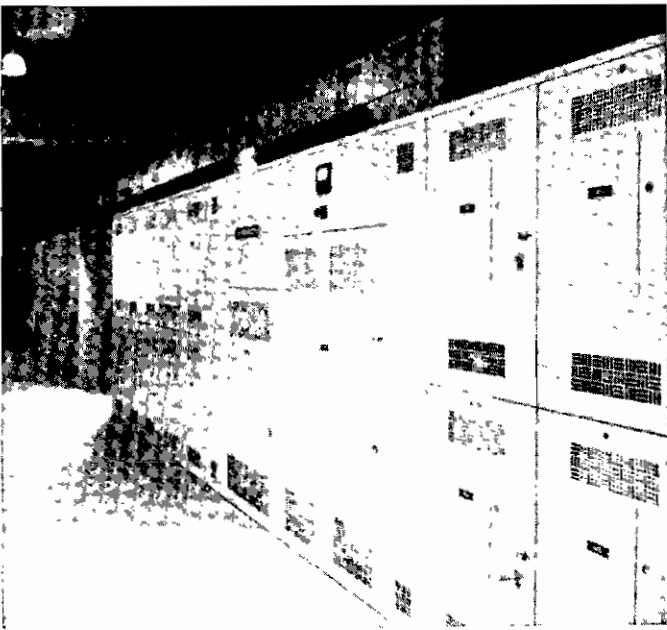

Fig. 39—Typical installation of low-voltage, metal-enclosed switchgear.

tive isolation of a faulty circuit. The metal-enclosed gear is factory assembled and tested and provides maximum reliability, safety and ease of maintenance with minimum interruption to service. These breakers may be used to provide control as well as running overload and short-circuit protection for individual motor circuits.

Even where unusual atmospheric conditions are encountered (see Sec. 30), low voltage air breakers may be used if they are mounted in suitable sealed enclosures.

Power Circuit Breakers — Medium Voltage — Circuit breakers intended for service on a-c circuits above 1500 volts are classified as power circuit breakers.

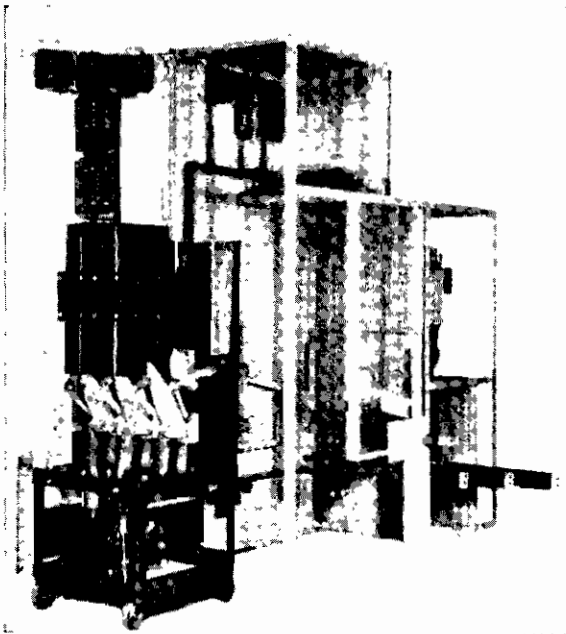

Fig. 40—Magnetic type air circuit breaker—4160 volts, 150-mva interrupting capacity, type 50-DH-150.

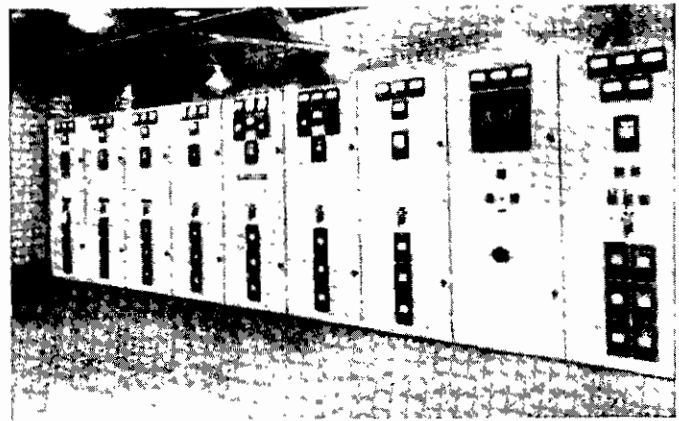

Fig. 41—Typical metal-clad drawout switchgear for 13.8 kv indoor service.

For indoor service at from 1.5 to 15.0 kv and up to 500 mva interrupting duty, magnetic-type air breakers in metal-clad assemblies have become predominant, although metal-clad oil breakers are also used under adverse atmospheric conditions. A typical breaker and assembly are shown in Figs. 40 and 41. Although interrupting time and space required are the same for medium voltage air and oil breakers, the freedom from oil-fire hazard and lower maintenance on repetitive service are distinct advantages of the air breakers. Many such breakers are used, both for power and lighting feeders and to control individual large industrial or powerhouse-auxiliary motors.

For indoor service at interrupting ratings above 500 mva, and for any rating at voltages between 15 and 34.5

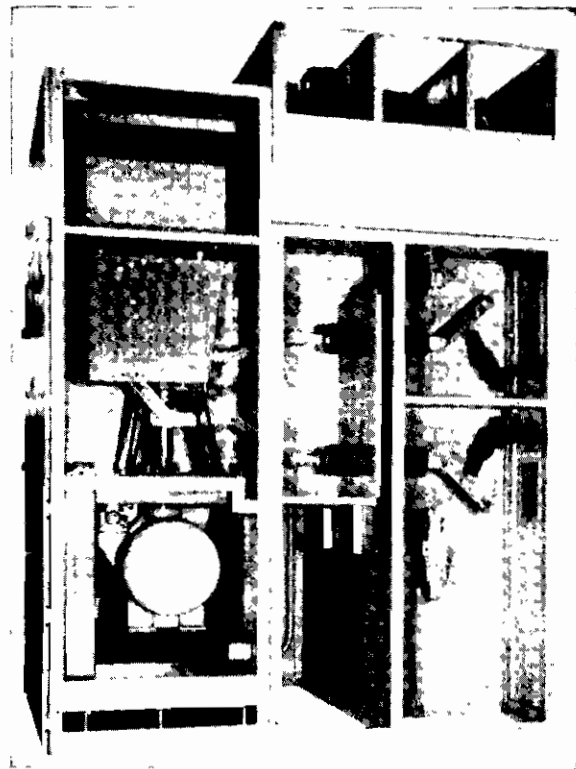

Fig. 42—Compressed air circuit breaker in station cubicle—15-H kv insulation class.

kv, compressed-air breakers mounted in station cubicles have become standard. A typical unit is shown in Fig. 42.

Circuit-breaker practice in outdoor substations is more varied than in indoor service because there is a greater range in the requirements. In rural and outlying substa-

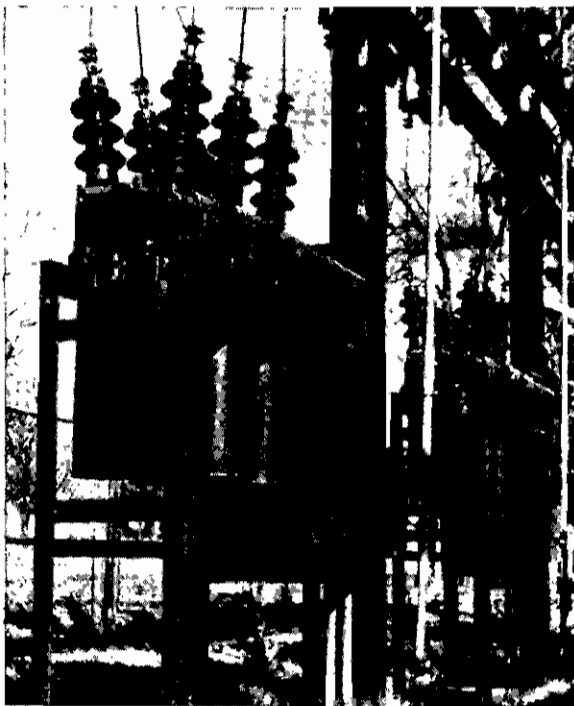

Fig. 43—Installation view of outdoor 23 kv, 250 000 kva, oil circuit breakers.

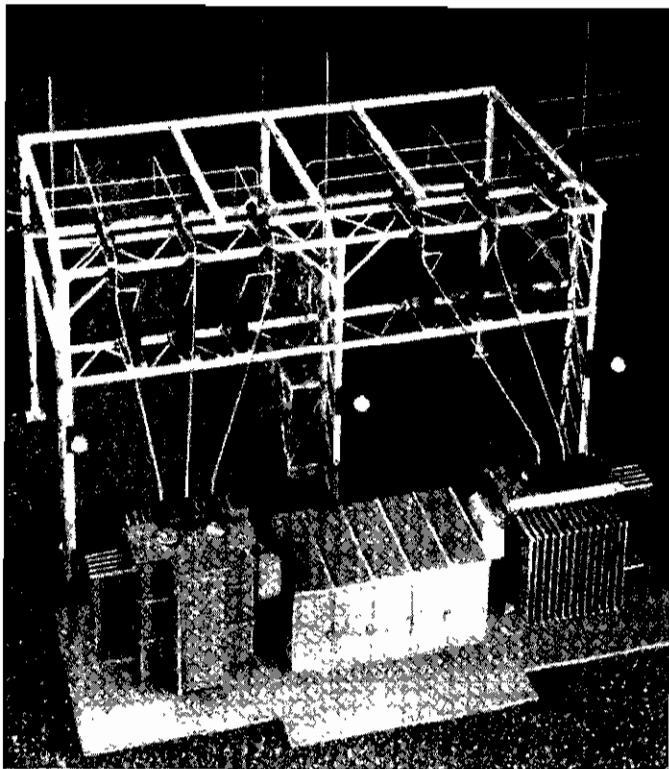

Fig. 44—Typical outdoor coordinated unit substation.

tions both normal load and interrupting kva are relatively low, and such factors as fire hazard, space requirements, appearance and rapid maintenance may not be critical. For such service frame-mounted oil breakers with open buses and disconnecting switches are frequently used because of lower cost. A typical installation is shown in Fig. 43.

For suburban and urban outdoor service up to 15 kv and up to 500-mva interrupting duty the many advantages of metal-clad oil-less switchgear (freedom from oil-fire hazard, compactness, appearance, ease of maintenance and flexibility) have resulted in the use of such gear for the

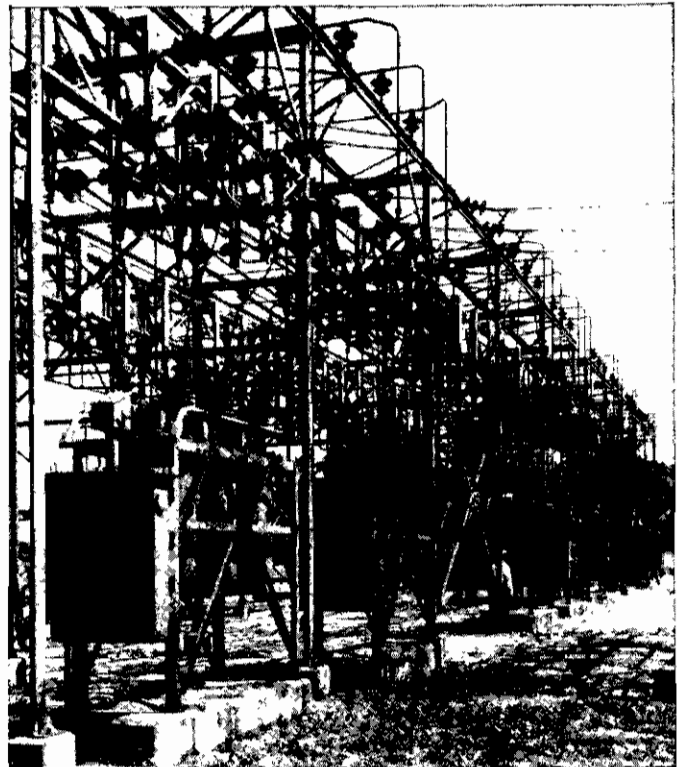

Fig. 45—34.5-kv, 1000-mva, frame-mounted, oil circuit breakers.

majority of these substations. The metal-clad gear is usually throat connected to the transformer(s) although roof bushings are sometimes used, especially with single-phase transformers. A typical installation is shown in Fig. 44. The cost comparison between open gear and metal clad varies with the voltage and kva rating, the type of open structure used, the cost of real estate, the labor facilities of the utility, and the method used in estimating overhead and fixed charges.

Oil circuit breakers are used where severe atmospheric conditions are encountered, either frame mounted or in metal-clad structures.

For outdoor service at interrupting ratings above 500 mva and for all interrupting ratings at voltages between 15- and 34.5-kv, oil breakers are essentially standard. A typical installation is shown in Fig. 45.

High-Voltage Breakers—Almost all circuit breakers rated above 34.5 kv are mounted outdoors and are oil

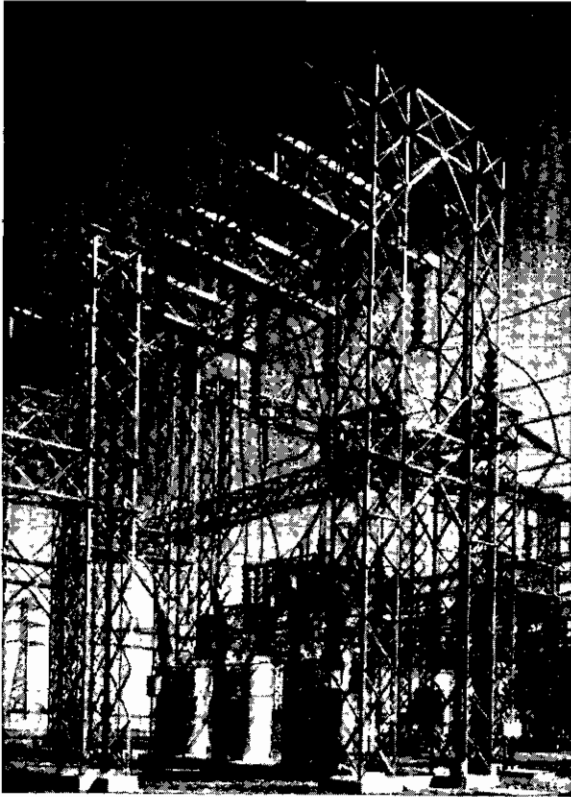

Fig. 46—230-kv, 3500-mva, floor-mounted, oil circuit breaker.

breakers of the grounded metal-tank type. Pneumatic operating mechanisms predominate and these can be arranged to give 20-cycle reclosing. A 230-kv installation is shown in Fig. 46.

Some experimental installations have been made of air-blast and oil-poor breakers at high voltage and a table of ratings for such breakers has been included in the standards as a guide for development. At the present time it is difficult to produce and install an oil-less outdoor breaker having current transformers and potential devices to compete economically with conventional oil breakers. There is also the hazard of fragile porcelain structures. So far there is no definite indication of the place such breakers will fill in normal practice.

29. Standard Ratings of Circuit Breakers

The standard ratings of the several classes of circuit breakers are defined in ASA, AIEE, NEMA, and Underwriters Laboratories standards.¹⁰⁸⁻¹¹¹ It is not the intention here to review these ratings in detail, only to discuss the principal factors involved in the selection of a circuit breaker for a particular application.

Rated Voltage—In general a circuit breaker is given a rated voltage which designates the maximum *nominal* system voltage for which the breaker is intended and also a maximum design voltage which designates the maximum operating voltage for which it is intended. For certain low-voltage breakers this distinction is not made and rated voltage should be taken as maximum. Standard voltage ratings of power circuit breakers are in terms of three-phase line-to-line voltage.

Standard values of rated voltage are based on operation at altitudes of 3300 feet or less. Standard equipment may be operated at higher altitudes if the maximum operating voltage is not more than the maximum design voltage times a correction factor, as follows:

Altitude in Feet	Voltage Correction Factor
3300	1.00
4000	0.98
5000	0.95
10000	0.80

Operation at altitudes other than those listed is covered in AIEE #1B but operation above 10 000 feet should be given special consideration because of possible influence of altitude on interrupting capacity.

Rated Impulse Withstand Voltage—Impulse ratings of standard power circuit breakers are listed in ASA C 37.6. A correction (the same as that given above for rated voltage) should be made for the effect of altitude above 3300 feet on impulse strength. No such ratings are given for low-voltage air breakers because such breakers are seldom exposed to impulse voltages. When necessary, impulse strength could be taken as the crest of the 60-cycle test voltage.¹¹⁰

The surge protection of the system should be coordinated with the impulse strength of the breaker, both across the open contacts and to ground. Attention should also be given to increase in surge voltage because of reflections which occur at breakers when their contacts are open, especially where cables are involved.¹⁰⁴

Frequency—Standard power circuit breakers are rated at 60 cycles. Service at other frequencies must be given special consideration. Although standard 60-cycle power circuit breakers are given corresponding continuous-current ratings for 25-cycle service,¹⁰⁵ other ratings (e.g. interrupting capacity) must be checked and accessories must be made suitable. Low-voltage breakers are listed for 60-cycle service and for direct current. Service at other frequencies requires special consideration.

Rated Continuous Current—This rating is based on operation of the circuit breaker or switchgear assembly where the ambient temperature (measured outside the enclosure where such is supplied) does not exceed 40°C and the altitude does not exceed 3300 feet. Operation in higher ambient temperature must be given special consideration. Molded-case, thermal-trip, low-voltage circuit breakers are calibrated on the basis of an ambient temperature of 25°C. Operation in ambient temperatures other than 25°C will affect the tripping characteristic and must be taken into consideration. Standard equipment may be operated at higher altitudes by reducing the continuous current rating in accordance with the following table.

Altitude in Feet	Current Correction Factor
3300	1.00
4000	0.996
5000	0.99
10000	0.96

Rated Interrupting Current—Rated Interrupting Mva—Operating Duty—Interrupting Time—The rated interrupting current of a power circuit breaker is

based on the rms total current in any pole of the breaker at the time the breaker contacts part. (Note that this time may be considerably shorter than the interrupting time.) The correct value of rated interrupting current for an operating voltage other than rated value can be calculated by the following formula:

Amperes at operating voltage = amperes at rated voltage $\times \frac{\text{rated voltage}}{\text{operating voltage}}$. Operating voltage should, of course, not exceed the maximum design voltage. Also, no matter how low the voltage, the rated interrupting current is not increased above the *rated maximum interrupting current*. Standard rating tables¹⁰⁶ give the value of rated interrupting current at rated voltage as well as the rated maximum interrupting current and the corresponding operating voltage. Over this range of voltages the product of operating voltage and current is constant and this product times a phase-factor is called *rated interrupting mva*.

For 3-phase circuits the factor is 1.73, for 2-phase circuits 2.0, and for 1-phase circuits 1.0. However, standard breakers are rated only on a three-phase basis and rules are provided (given later in this chapter) for determining the equivalent three-phase interrupting ratings.

The above values of rated interrupting current are based on specified conditions of circuit recovery voltage, breaker performance, and also on *standard operating duty*. For power circuit breakers rated 50 mva and higher ("oil-tight or oil-less") this consists of two *unit operations* (CO) separated by a 15-second interval. Each unit operation consists of breaker closing followed by its opening without intentional time delay. This standard operating duty is designated by the expression, CO+15 sec.+CO. For power circuit breakers rated 25 mva and lower ("non-oil-tight") the standard operating duty consists of two unit operations separated by a two-minute interval (CO+2 min. +CO). For any other operating duty the standard interrupting ratings should be reduced in accordance with rules given in NEMA standards.¹⁰⁹ The following revision of the current rules is now being recommended by AIEE to ASA.

NEMA STANDARDS—RECLOSING DUTY CYCLE FACTORS FOR OIL-TIGHT AND OIL-LESS POWER CIRCUIT BREAKERS—REVISION OF 11/17/49

SG-6-90 BREAKER RATING FACTORS FOR RECLOSING SERVICE (Rev.)

A. The interrupting ratings of power circuit breakers may be reduced for operating duty cycles other than the standard, CO+15 Sec.+CO (See SG6-40, Par. B) to enable them to meet the standard of Interrupting Performance. (See SG6-40, Par. C)

Note: Such factors do not apply to highly repetitive duty at or near the continuous rating of the breaker.

B. For purposes of this section, the following duty cycles shall be considered as representing the Usual Duty Cycles for Reclosing

Reclosing Duty Cycle I O+15 Sec. **+CO+15 Sec.**
+CO+15 Sec.**+CO
Reclosing Duty Cycle II O+0 Sec.*+CO
Reclosing Duty Cycle III O+0 Sec.*+CO+15 Sec.**
+CO+15 Sec.**+CO

*Zero seconds shall be interpreted to mean no intentional time delay.

**15 seconds or longer.

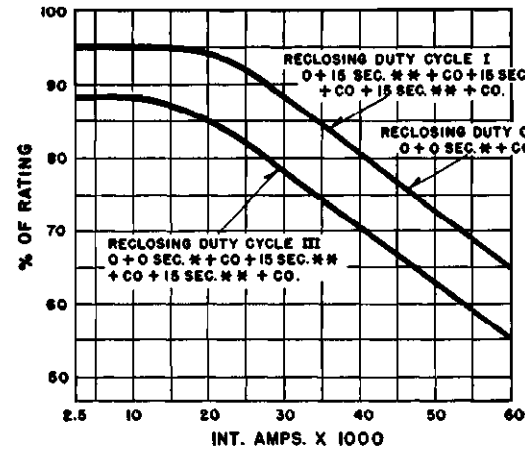

* ZERO SECONDS SHALL BE INTERPRETED TO MEAN NO INTENTIONAL TIME DELAY
** 15 SECONDS OR LONGER.

Fig. 47—Breaker rating factors for the usual reclosing duty cycles.

C. The Breaker Rating Factors for the Usual Reclosing Duty Cycles are obtained by reference to Figure 47. This gives the percentage rating factor for the duty cycle in question at the rated interrupting current at the circuit voltage of the system to which the breaker will be applied.

D. The breaker interrupting rating at the specified reclosing duty cycle is obtained by multiplying the rated interrupting amperes by the rating factor.

Example: Determine the interrupting rating of a 34.5 kv, 1000-mva breaker used at 23-kv on Reclosing Duty Cycle I.

1. Breaker Interrupting Rating on Standard Duty Cycle:
17 000 Amperes at 34.5-kv
25 000 Amperes at 23 kv
2. Figure 1, Curve A, gives a rating factor of 91.5 percent at 25 000 amperes for reclosing duty cycle I.
3. Breaker Interrupting Rating on Duty Cycle I at 23 kv = Rating Factor, 91.5 percent \times 25 000 Amperes = 22 900 Amperes.

E. Breaker Rating Factors for Other Than the Usual Reclosing Duty Cycles

1. The standard for the number of operations is two (2). Additional operations increase the duty on the contacts and therefore a rating factor is applied to enable circuit breakers to meet standards of interrupting performance. (See SG6-40, Par. C)

(a) For Three Operations—Use mean factor between 2 and 4 operations, (Standard and Duty Cycle I).

Example: O+15 Sec.+CO+15 Sec.+CO
% Factor = 97 for 20 000 Amperes

(b) For Five Operations—Use Factor obtained by reducing that for 4 operations (Duty Cycle I) by difference between 2 and 4 operations.

Example: O+15 Sec.+CO+15 Sec.+CO+15 Sec.
+CO+15 Sec.+CO
% Factor = 94 - 6 = 88 for 20 000 Amperes

2. The standard for the interval between operations is 15 seconds. Reducing this interval increases the interrupting duty and therefore a rating factor is applied to enable breaker to meet standards of interrupting performance. (See SG6-40 Par. C)

(a) For Two Operations—Reduce 100 percent factor for 15 seconds by an amount equal to proportionate part of the reduction for zero interval as determined by the ratio of the times.

Example: O+5 Sec.+CO
 % Factor = $100 - \frac{1}{3}(100 - 94) = 96$ for 20 000 Amperes

(b) For Four Operations—Multiply the factor for Duty Cycle I by the appropriate factor determined under paragraph 2 (a) for each interval less than standard.

Example: O+5 Sec.+CO+5 Sec.+CO+5 Sec.+CO
 % Factor = $94 \times 96 \times 96 \times 96 = 83$ for 20 000 Amperes

(c) For Three or Five Operations—Use combination of Rule 1 and Rule 2 (a) applied for each interval.

Example: O+5 Sec.+CO+5 Sec.+C
 % Factor = $97 \times 96 \times 96 = 89$ for 20 000 Amperes

3. The usual instantaneous reclosing cycles are Duty Cycles II and III. Variations are in the number of operations.

(a) For Three Operations—Use mean between factors for Duty Cycles II and III.

Example: O+0 Sec.+CO+15 Sec.+CO
 % Factor = $\frac{94+85}{2} = 89.5$ for 20 000 Amperes

(b) For Five Operations—Use factor by reducing that for 4 operations (Duty Cycle III) by difference between 2 and 4 operations.

Example: O+0 Sec.+CO+15 Sec.+CO+15 Sec.+CO+15 Sec.+CO
 % Factor = $85 - (94 - 85) = 76$ for 20 000 amperes

The reclosing duty cycle factors for breakers rated 25 mva and below (non-oil-tight circuit breakers) are given in Table 5.

TABLE 5*—RECLOSED DUTY CYCLE FACTORS FOR NON OIL-TIGHT OIL POWER CIRCUIT BREAKERS

Duty Cycle	Percentage of Standard Interrupting Capacity Rating
B—CO+2 min.+CO.....	100
C—CO+2 min.+CO+2 min.+CO+2 min.+CO	70
D—CO+30sec.+CO+30 sec.+CO+30sec.+CO	60
**E—CO+0 sec.+CO+0 sec.+CO+0 sec.+CO..	25
F—300 cycles CO at 15-min. intervals.....	30
**G—CO+0 sec.+CO+30 sec.+CO+75 sec.+CO	30
H—CO+15sec.+CO+30sec.+CO+75sec.+CO	40
I—CO+60 sec.+CO+60 sec.+CO.....	70
J—CO+15 sec.+CO.....	60

NOTE—The standard operating duty (duty cycle) for non oil-tight oil power circuit breakers is 2-CO operations with a 2-minute interval.
 *Reproduced from NEMA 46-118, SG6-90.
 **Zero seconds shall be interpreted to mean no intentional time delay.

The interrupting time of a power circuit breaker is the maximum interval from the time the trip coil is energized at normal control voltage until the arc is extinguished. This time is published for standard power breakers for

the interruption of currents from 25 percent to 100 percent of the rated value.

The interrupting rating of *low-voltage air circuit breakers* is based on the rms total short-circuit current which would occur at the end of $\frac{1}{2}$ cycle at the breaker location if the line terminals of the breaker were short-circuited. The impedance of the breaker which interrupts the circuit should *not* be included in calculating the interrupting duty. Also, for three-phase a-c circuits the breaker rated interrupting current should be chosen on the basis of the *average* of the currents in the three phases. For single-phase circuits the average current which would occur for three successive short-circuits should be used. For average systems the average 3-phase or 1-phase rms total current will be equal to 1.25 times the initial subtransient symmetrical current.

Low-voltage air breakers for d-c service are also applied on the basis of the short-circuit current without the breaker in place; however, the maximum current is measured.

The standard rated interrupting current of low-voltage air circuit-breakers is based on a standard operating duty designated O+2 min+CO. The breaker opens the circuit and, after a 2-minute interval, is reclosed on the fault, which it opens without purposely delayed action.

For other interrupting duty the standard interrupting rating should be multiplied by factors given in Table 6.

TABLE 6**—OPERATING DUTY FOR RECLOSED SERVICE FOR LARGE AIR CIRCUIT BREAKERS

Duty Cycle	Percentage of Published Interrupting Rating
B—O+2 min.+CO.....	100
C—O+2 min.+CO+2 min.+CO+2 min.+CO..	70
D—O+30sec.+CO+30 sec.+CO+30 sec.+CO..	60
*E—O+0 sec.+CO+0 sec.+CO+0 sec.+CO....	25
F—300 cycles CO+15 min. intervals.....	30
*G—O+0 sec.+CO+30 sec.+CO+75 sec.+CO..	30
H—O+15 sec.+CO+30 sec.+CO+75 sec.+CO..	40
I—O+60 sec.+CO+60 sec.+CO.....	70
J—O+15 sec.+CO.....	60

*Zero seconds shall be interpreted to mean no intentional time delay.
 **Copied from SG7-63 of NEMA std. 46-109.
 NOTE—Derating factors are not available for automatic reclosing service on d-c circuits. Circuit breakers designed for the purpose are ordinarily required.

This table does not apply to molded-case breakers because they are not used on reclosing service.

Rated Momentary Current—The maximum rms total current (including the d-c component) through a breaker, measured during the maximum cycle, should not exceed the rated momentary current. For power circuit breakers this rating applies to each pole of the breaker taken individually and for the worst condition of asymmetry.

Rated Four-Second Current—A four-second current rating is given for power circuit breakers based on the rms total current measured or calculated at the end of one second. For standard breakers it is numerically equal to the rated maximum interrupting current, and 1/1.6 times the momentary current. For normal circuits this means that the permissible duration of the maximum permissible

fault current is four seconds. No current rating is given for times longer than four seconds but less than continuous.

No similar short-time rating is given for low-voltage breakers because such breakers are normally equipped with direct acting series overload trips.

Rated Making Current—This rating is given to power operated power circuit breakers only. No provision is made for manual closing of oil-less breakers or for oil breakers above 250 mva. It is essentially a design requirement to preclude welding of contacts or other undue damage when a breaker closes on a fault. It is required that the breaker “be immediately opened without purposely delayed action.”

The values of momentary and making-current rating for present standard breakers have been so selected that these ratings will not normally limit application of the breakers when they are applied in accordance with the recommended “simplified procedure,” which will be described later in this chapter. An exception may occur where motors produce a large portion of the fault current. Breakers may also be applied on the basis of decrement curves or detailed calculations and, under unusual conditions or in existing installations, momentary current may be the limiting rating of the breaker.

Rated Latching Current—This rating is distinguished from rated making current in that the breaker must latch when it closes on a fault of the specified rms total current magnitude. Thus delayed tripping is permissible within this rating if the magnitude, duration, and operating duty are within the short-time and interrupting ratings. For present standard power circuit breakers the latching current rating is numerically equal to both the four-second rating and the maximum interrupting current rating. However, the latching current is measured during the maximum cycle whereas the interrupting rating is measured at the time the contacts part and the four-second rating is measured at the end of one second.

Reclosing Time—For outdoor reclosing oil-circuit breakers standard and fast reclosing times are shown in Table 7. These values apply only to breakers which have a continuous current rating of 1200 amperes or less when operated in conjunction with an automatic reclosing device.

30. Selection of Circuit Breakers for Specific System Conditions

General—The great majority of circuit breakers are applied as three-pole, gang-operated breakers in three-phase power systems which are ungrounded or grounded at the neutrals of generators or transformers. Consequently the standard ratings of most circuit breakers are given on this basis. For such an application it is sufficient (in so far as rating is concerned) to select a breaker such that none of its standard ratings will be exceeded under any condition of system operation.

For example, the voltage rating should include allowances, where applicable, for such factors as line voltage regulation, shunt or series capacitance, overexcited or overspeed operation of synchronous machines, line-drop-compensation of tap changers or feeder voltage regulators and the operation of transformers on tap positions other than the nominal values. Both voltage and continuous current ratings should take into account future load growth and the contingencies associated with circuit or apparatus outages. The various ratings associated with interruption of faults should include allowances for increase in generation, addition of parallel circuits or transformers, and any other system changes which would increase interrupting duty. The calculation of fault currents and their interpretation in terms of interrupting ratings will be considered separately in Sec. IV.

System frequency will usually be substantially constant at 60-cycles. Operation at other frequencies or at varying frequency requires special consideration.

The interrupting time of the circuit breakers themselves is subject to choice in few cases. Considerations of transient stability may dictate one or another type of relaying system in order to obtain sufficiently fast clearing. However, considerations of system operation and stability may or may not call for fast reclosing, and a choice should be indicated.

Determination of Equivalent Three-Phase Voltage and Interrupting Ratings—The standard ratings of most power circuit breakers are given in terms of three-pole breakers for three-phase systems. These voltage ratings are based on the line-to-line voltage of the circuit, and the interrupting ratings are given in amperes and approximate three-phase kva. In order to select the proper 1-, 2-, 3-, or 4-pole circuit breaker for special services on three-phase circuits, and for use on two-phase and single-phase circuits, the equivalent three-phase breaker rating can be determined from Tables 8, 9, and 10.

First, the three-phase voltage rating of the breaker type must be equal to or greater than the voltage determined from column 5 of the tables.

Second, make a tentative breaker selection on the basis of equivalent three-phase kva in accordance with column 6 of the tables. If the computed equivalent three-phase kva is more than 95 percent of the approximate kva rating of the breaker type a further check must be made. In such cases the product of rated voltage times rated interrupting current times 1.73 (standard three-phase ratings) must equal or exceed the equivalent three-phase kva calculated in column 6.

TABLE 7*—RECLOSEING TIME FOR OUTDOOR RECLOSEING OIL CIRCUIT BREAKERS (60-CYCLE BASIS)

Rated Voltage	Reclosing Time-Cycles	
	Standard	Fast
7.5 to 23 kv incl. (under 500 mva).....	30	30
15 to 23 kv incl. (500 mva and higher).....	45	30
34.5 to 69 kv incl. (500 mva and higher).....	45	20
115 to 230 kv incl. (500 mva and higher).....	30	20

NOTE I—These time values assume rated control voltage or operating pressure maintained at the mechanism. In case the control voltage or pressure drops to 90 percent of rated voltage or pressure, the reclosing times will be increased to 110 percent of that tabulated.

NOTE II—Reclosing time for oil-less breakers has not yet been standardized.
*This table was reproduced from NEMA standard 46-116 SG6-95.

TABLE 8—DETERMINATION OF EQUIVALENT THREE-PHASE VOLTAGE AND INTERRUPTING RATINGS FOR THREE-PHASE SYSTEMS

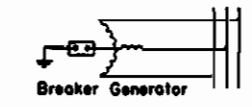
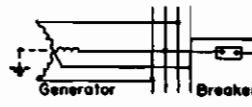
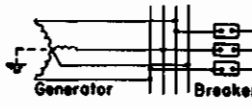
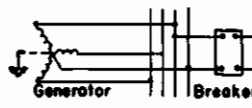
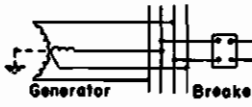
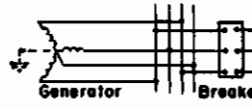
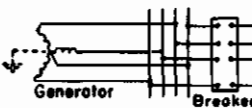
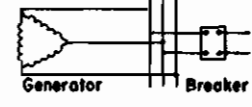
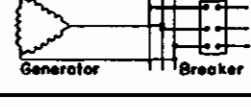

Line No.	Typical System Connections	Type of System	No. of Breaker Poles	Select a breaker whose voltage rating is equal or greater than the equivalent 3-phase voltage (V_3) as determined below.	Select a breaker whose approximate 3-phase kv-a. interrupting rating is equal to or greater than the value as determined below. I = Required interrupting current at service voltage. † V_3 = Equivalent 3-phase voltage as obtained from adjacent column.
1		3-wire grounded or 4-wire with neutral grounded or not	1 pole in neutral wire	Greatest wire to wire voltage	$0.87 I \times 1.73 V_3$
2		3-wire grounded or 4-wire with neutral grounded or not	1 pole in outside wire	Greatest wire to wire voltage	$0.87 I \times 1.73 V_3^{**}$
3		3-wire grounded or 4-wire with neutral grounded or not	Independent 1 pole breaker in an outside wire	1.15 times greatest wire to wire voltage*	$I \times 1.73 V_3$
4		3-wire grounded or 4-wire with neutral grounded or not	2 poles in outside and neutral wire respectively	Greatest wire to wire voltage	$I \times 1.73 V_3$
5		3-wire grounded or 4-wire with neutral grounded or not	2 poles single-phase outside wire	Greatest wire to wire voltage	$I \times 1.73 V_3$
6		3 wire grounded or 4-wire with neutral grounded or not	3 poles 3-phase circuit	Greatest wire to wire voltage	$I \times 1.73 V_3$
7		3-wire grounded or 4-wire with neutral grounded or not	4 poles	Greatest wire to wire voltage	$I \times 1.73 V_3$
8		3-wire ungrounded	2 poles single-phase circuit	Greatest wire to wire voltage	$I \times 1.73 V_3$
9		3-wire ungrounded	3 poles	Greatest wire to wire voltage	$I \times 1.73 V_3$

† This value must not exceed the maximum current interrupting rating listed in breaker interrupting tables.

* See NEMA rule SGG-210 regarding exceptions for 8 cycle breakers. In such instances use Line 6.

** These recommendations apply to isolated feeders only. Where possibility of phase to phase faults exist refer to Line 3 for application.

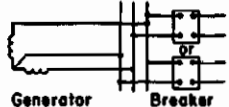
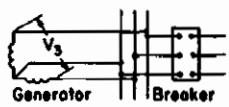
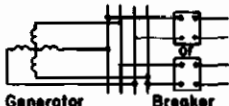
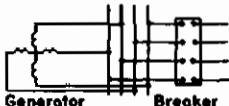
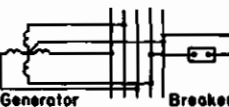
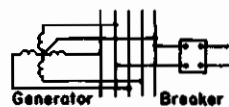
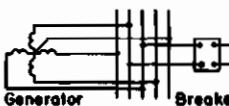
TABLE 9—DETERMINATION OF EQUIVALENT THREE-PHASE VOLTAGE AND INTERRUPTING RATINGS FOR TWO-PHASE SYSTEMS

Line No.	Typical System Connections	Type of System	No. of Breaker Poles	Select a breaker whose voltage rating is equal or greater than the equivalent 3-phase voltage (V_3) as determined below.	Select a breaker whose approximate 3-phase, kv-a, interrupting rating is equal or greater than the value as determined below. I = Required interrupting current at service voltage.† V_3 = Equivalent 3-phase voltage as obtained from adjacent column.
1		3-wire grounded or not	2 poles any two wires	Greatest wire to wire voltage	*I × 1.73 V_3
2		3-wire grounded or not	3 poles	Greatest wire to wire voltage	*I × 1.73 V_3
3		4-wire ungrounded	2-2 pole	Greatest wire to wire voltage	I × 1.73 V_3
4		4-wire ungrounded	4 poles	Greatest wire to wire voltage	I × 1.73 V_3
5		5-wire grounded or not	1 pole any "outside wire"	Greatest wire to wire voltage	0.87 I × 1.73 V_3
6		5-wire grounded or not	2 poles any "outside wire" and neutral	Greatest wire to wire voltage	0.87 I × 1.73 V_3
7		5-wire grounded or not	2 poles d-c. any "outside wires"	Greatest wire to wire voltage	0.87 I × 1.73 V_3
8		5-wire grounded or not	4 poles all "outside wires"	Greatest wire to wire voltage	I × 1.73 V_3

* I is the current in one of the outside wires.

† This value must not exceed the maximum current interrupting rating listed in breaker interrupting tables.

TABLE 10—DETERMINATION OF EQUIVALENT THREE-PHASE VOLTAGE AND INTERRUPTING RATINGS FOR SINGLE-PHASE SYSTEMS

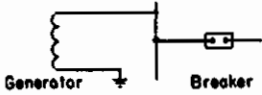
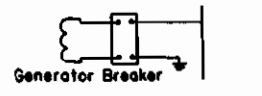
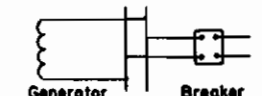
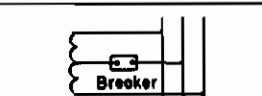
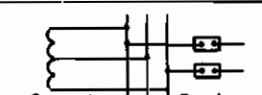
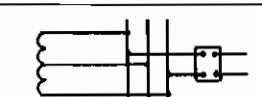
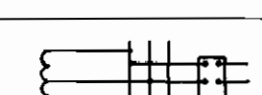
Line No.	Typical System Connections	Type of System	No. of Breaker Poles	Select a breaker whose voltage rating is equal or greater than the equivalent 3-phase voltage (V_3) as determined below.	Select a breaker whose approximate 3-phase, kv-a, interrupting rating is equal or greater than the value as determined below. I = Required interrupting current at service voltage.† V_3 = Equivalent 3-phase voltage as obtained from adjacent column.
1		2-wire one side grounded	1	1.73 times wire to ground voltage	$0.87 I \times 1.73 V_3$ (based on NEMA rule SG6-205)
2		2-wire one side grounded	2	1.73 times wire to ground voltage	$I \times V_3$ (based on NEMA rule SG6-205)
3		2-wire ungrounded	2	wire to wire voltage	$I \times 1.73 V_3$
4		3-wire neutral may or may not be grounded	1 pole in neutral circuit	1.73 times higher line to neutral voltage	$0.87 I \times 1.73 V_3$
5		3-wire neutral may or may not be grounded	1 pole either "outside wire"*	1.73 times respective line to neutral voltage	$0.87 I \times 1.73 V_3$
6		3-wire neutral may or may not be grounded	2 outside wires	Greatest wire to wire voltage	$I \times 1.73 V_3$
7		3-wire neutral may or may not be grounded	3	Greatest wire to wire voltage	$I \times 1.73 V_3$

* Where 1 phase, 3-wire system has unequal voltages to neutral and 2 single-pole breakers are used in the outside wires, the lower voltage breaker must be interlocked to prevent its tripping for "outside wire" faults, until the higher voltage breaker has first cleared the fault, unless both breakers are selected on high-voltage basis.
† This value must not exceed the maximum current interrupting rating listed in breaker interrupting tables.

Third, the short-time current rating and the interrupting capacity current limitation must not be exceeded.

The fault current may be calculated by one of the methods described in the next section, and should be checked for all types of faults.

Switching of Capacitive Current—When circuit breakers are used to switch the charging current of lines or cables or to switch capacitor banks, abnormally high voltages can be produced by restriking in the breaker. Experience¹⁰¹ has indicated that transient voltages which result from such restriking will seldom exceed 2.5 times normal line-to-neutral crest voltage on circuits having effectively grounded neutrals. There is relatively little hazard to either the breakers or to other apparatus on such circuits. There are insufficient data on ungrounded or impedance-grounded systems to draw conclusions.

Lightning arresters may be damaged if the voltages developed are sufficient to cause them to discharge and if, in addition, the line capacitance is large. Because of the random nature of the phenomena involved it is not possible

at this time to give specific limits for capacitive switching. As an approximate guide special consideration should be given when one desires to switch 69-kv cables which exceed 9 miles in length or 115- and 138-kv cables longer than 7 miles.

Another problem to be considered is that a large momentary current may flow when one capacitor bank is switched in parallel with another capacitor bank. This current is a function of the capacitance involved and the inductance of the leads connecting the two banks. This current may be calculated¹⁰² and should not exceed the momentary rating of the circuit breaker.

Conditions Affecting Construction or Protective Features—There are unusual conditions which, where they exist, should be given special consideration in the selection and design of the apparatus. Among such unusual conditions are:

- (1) Exposure to damaging fumes or vapors, excessive or abrasive dust, explosive mixtures of dust or gases, steam, salt spray, excessive moisture, or dripping water, etc.;

- (2) Exposure to abnormal vibration, shocks or tilting;
- (3) Exposure to excessively high or low temperatures;
- (4) Exposure to unusual transportation or storage conditions;
- (5) Unusual space limitations;
- (6) Unusual operating duty, frequency of operation, difficulty of maintenance, etc.

31. Requirements for Low-Voltage Air Circuit Breakers in Cascade Arrangement*

"When a plurality of low voltage air circuit breakers are connected in series in a distribution system, and the breakers beyond those nearest to the source are applied in the following correlated manner, they are said to be in a cascade arrangement.

"In this cascade arrangement, breakers toward the source are provided with instantaneous tripping for current values which may obtain for faults beyond other breakers nearer the load. Hence, breakers in the series, other than the breaker closest to a fault may trip and interrupt loads on other than the fault circuit. Such arrangements are used only where the consequent possible sacrifice in service continuity is acceptable. Where continuity of service is desired, selective tripping arrangements of fully rated breakers are required. Where continuity of service is not important, properly selected breakers may be applied in cascade.

"The following requirements shall be observed:

- (a) Cascading shall be limited to either two or three steps of interrupting rating.

(1). The interrupting rating of the breaker or breakers nearest the source of power shall be equal to at least 100 percent of the short-circuit current as calculated in accordance with section 29. The breaker or breakers in this step shall be equipped with instantaneous features set to trip at a value of current that will give back-up protection whenever the breaker in the next lower step carries current greater than 80 percent of its interrupting rating.

(2) The breaker or breakers in the second step shall be selected so that the calculated short circuit current through the first step plus motor contribution in the second step, will not exceed 200 percent of their interrupting rating. The breaker or breakers shall be equipped with instantaneous trip set at a value of current that will give back-up protection whenever the breaker in the next lower step carries current greater than 80 percent of its interrupting rating. For the second step of a two step cascade the breaker or breakers shall have an instantaneous trip setting above the starting inrush current of the load.

(3) The breaker or breakers in the third step shall be selected so that the calculated short circuit current through the first step, plus motor contribution of the second and third steps, will not exceed 300 percent of their interrupting rating. The breaker or breakers shall have instantaneous trips set above the starting inrush current of the load.

(b). All circuit breakers subjected to fault currents in excess of their interrupting rating shall be electrically operated.

(c). Where cascading is proposed, recommendations shall be obtained from the manufacturer in order to insure proper coordination between circuit breakers.

(d). The operation of breakers in excess of their interrupting rating is limited to one operation, after which inspection, replacement, or maintenance may be required."

In calculating the short circuit current through each step in (a1), (a2), and (a3) above it is permissible to include the impedance of all circuit elements (including breaker trip coils) between the line terminals of the breaker in question and the source, but not the impedance of the breaker for which the interrupting current rating is being determined. For example, the impedance of breakers in the first two steps may be included in the calculation to determine the fault current to which the breakers in the third step will be exposed. However, the impedance of the third-step breakers should not be included.

32. Selective Tripping of Low Voltage Air Circuit Breakers*

"Properly selected air circuit breakers may be applied to low voltage circuits to obtain selective tripping. The following requirements shall be observed:

(a) Each air circuit breaker must have an interrupting rating equal to or greater than the available short circuit current at the point of application.

(b) Each air circuit breaker, except those having instantaneous trips (such as the one farthest removed from the source of power), must have a short-time rating equal to or greater than the available current at the point of application.

(c) The time-current characteristics of each air circuit breaker at all values of available overcurrent shall be such as to insure that the circuit breaker nearest the fault shall function to remove the overcurrent conditions, and breakers nearer the source shall remain closed and continue to carry the remaining load current.

(d) To insure that each breaker shall function to meet the requirements of paragraph (c) above, the time current characteristics of adjacent breakers must not overlap. The pickup settings and time delay bands of both the long-time and short-time delay elements must be properly selected.

(e) Manually operated circuit breakers shall be limited to applications in which delayed tripping requirements do not exceed 15 000 amperes or 15 times the coil rating, whichever is greater.

(f) The time-current characteristics of a breaker in a selective system shall be such that up to four breakers may be operated selectively in series, when required. One of these breakers shall be a load breaker equipped with an instantaneous trip element.

NOTE: Attention is directed to the fact that operation of selective tripping requires coordination with the rest of the system; as for instance, the low voltage side of a trans-

*Taken in part from the current proposed revision of NEMA Standards 46-109—not applicable to molded-case breakers

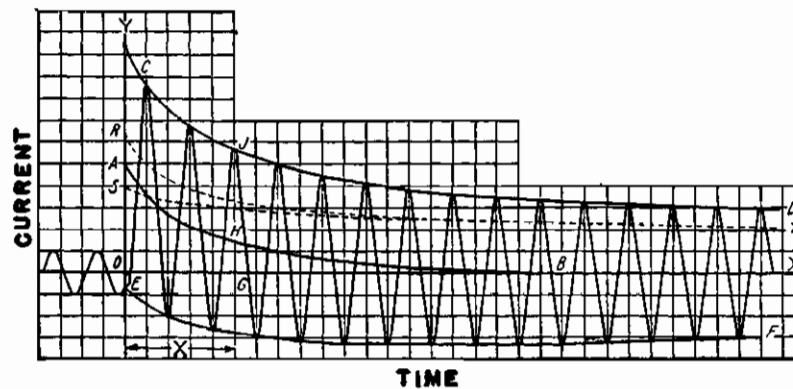

Fig. 48—Typical fault on a three-phase a-c system.

former bank requires that in the application of relays or fuses on the high side, proper coordinating steps should be taken.”

V. FAULT CALCULATIONS

In order to determine the momentary and interrupting duty on circuit breakers and to make preliminary relay settings it is necessary to predict the fault currents that may occur at each circuit breaker location. This information is sometimes available from tests or from previous calculations on adjacent circuits, but must frequently be calculated for a new system or extension. The rigorous determination of short-circuit currents as a function of time involves too laborious a calculation to be practical. Thus, some approximation is required, and a degree of judgment must be used in the application of any method proposed. In the following paragraphs several such methods will be discussed, including the simplified procedure suggested by the AIEE Protective Devices Committee.

In using any of these calculating procedures it is necessary to determine the system impedance as viewed from the point of fault, and the current distribution for different kinds of faults. Such calculations for relatively simple systems or parts of systems can be made directly. The network solutions described in Chap. 10 and the method of symmetrical components given in Chap. 2 are helpful in such calculations. The calculation of faults by these methods on many modern interconnected systems may become entirely too involved. Such systems can be represented in miniature on an a-c or d-c network calculator. Fault currents can be determined from calculator readings in a relatively short time. A description of an a-c network calculator is given in Sec. 35 of Chap. 13. A d-c network calculator can be used for studies where either resistance or reactance alone is sufficient to represent the system. Network calculators are also used in studies of load-current distribution, voltage regulation, transient overvoltage, and transient and steady-state stability.

33. Components of Fault Current

Before discussing specific methods of fault calculation for circuit-breaker and relay application the current components of a typical fault on an a-c system will be reviewed briefly. A more complete analysis is given in Chap. 6.

The current in one phase for a three-phase fault on an a-c system is shown as a function of time by the curve

EX of Fig. 48. In this diagram OX is the line of zero current and O represents the time at which the fault has occurred. The current to the left of OY is the load current prior to the fault. The short-circuit current wave is unsymmetrical with respect to the OX axis immediately after the short circuit, but during increasing increments of time it approaches a position of symmetry. This asymmetry is dependent upon the point of the voltage wave at which the short circuit occurs. It is possible, by short circuiting at different points on the normal voltage wave, to secure short-circuit current waves ranging anywhere from those symmetrical about the OX axis to those totally asymmetrical. CD is a curve passing through the maxima of the wave of the total current, and EF is a curve passing through the minima. AB is a curve cutting the vertical everywhere midway between CD and EF .

The wave of total current with crests along curves CD and EF and with ordinates measured from the axis OX can be resolved into two components, namely:

1. A direct-current component.
2. An alternating-current component.

The *direct-current component* is determined at any instant by the ordinate GH of the curve AB , at the time X .

The *alternating-current component* is a wave with a crest value at any time equal to the difference between the ordinates of the curves CD and AB . This difference at the time X has the value HJ . The rms values of this alternating-current component are shown on curve ST . At any instant, this component is considered to have the same rms value as an alternating wave of constant amplitude with crest value one-half the distance between curves CD and EF at that instant.

The rms value of the total current wave under short circuit at any instant is the square root of the sum of the squares of the direct-current component and the rms value of the alternating-current component at that instant. The rms values of this total current are shown on the curve RT . The rms value of the total current at the time of parting of the circuit-breaker contacts determines the interrupting rating of a power circuit breaker.

34. Simplified Procedure for Calculating Short-Circuit Currents for the Application of Circuit Breakers and Relays

A simplified procedure for the calculation of short-circuit currents has been presented in reports¹¹⁴⁻¹¹⁶ sponsored

TABLE 11—REACTANCE QUANTITIES AND MULTIPLYING FACTORS FOR APPLICATION OF CIRCUIT BREAKERS

	Reactance Quantity for Use in X_1			
	Multi- plying Factor	Synchronous Generators & Condensers	Synchronous Motors	Induction Machines
A. Circuit Breaker Interrupting Duty				
1. General case				
8-cycle or slower circuit breakers*	1.0	subtransient**	transient	neglect
5-cycle circuit breaker	1.1			
3-cycle circuit breaker	1.2			
2-cycle circuit breaker	1.4			
2. Special case for circuit breakers at generator voltage only. For short-circuit calculations of more than 500,000 kva (before the application of any multiplying factor) fed predominantly direct from generators, or through current-limiting reactors only				
8-cycle or slower circuit breakers*	1.1	subtransient**	transient	neglect
5-cycle circuit breakers	1.2			
3-cycle circuit breakers	1.3			
2-cycle circuit breakers	1.5			
3. Air circuit breakers rated 600 volts and less	1.25	subtransient	subtransient	subtransient
B. Mechanical Stresses and Momentary Duty of Circuit Breakers				
1. General case	1.6	subtransient	subtransient	subtransient
2. At 5 000 volts and below, unless current is fed predominantly by directly connected synchronous machines or through reactors	1.5	subtransient	subtransient	subtransient

* As old circuit breakers are slower than modern ones, it might be expected a low multiplier could be used with old circuit breakers. However, modern circuit breakers are likely to be more effective than their slower predecessors, and, therefore, the application procedure with the older circuit breakers should be more conservative than with modern circuit breakers. Also, there is no assurance that a short circuit will not change its character and initiate a higher current flow through a circuit breaker while it is opening. Consequently the factors to be used with older and slower circuit breakers well may be the same as for modern eight-cycle circuit breakers.
 ** This is based on the condition that any hydroelectric generators involved have amortisseur windings. For hydroelectric generators without amortisseur windings, a value of 75 percent of the transient reactance should be used for this calculation rather than the subtransient value.

by the Protective Devices Committee of the AIEE. This method has been found satisfactory and is intended for general use by the industry as a simplified method of approximating the magnitude of fault currents. However, other more rigorous methods should be used when required.

The new method is based upon the determination of an initial value of rms symmetrical current (a-c component) to which multiplying factors are applied for application purposes. In the determination of this current, the following symbols are used:

- E = line-to-neutral voltage.
- X_1 = positive sequence reactance viewed from the point of fault, including transient or subtransient direct-axis rated voltage reactance of machines as specified in Tables 11 and 12 in ohms per phase.
- X_0 = zero-sequence reactance.
- R_0 = zero-sequence resistance.

(a) **Circuit Breaker Application**—(1) Determine the “highest value of rms symmetrical current for any type of fault” equal to E/X_1 or $3E/(2X_1+X_0)$, whichever is greater, except that when R_0 is greater than $2.23X_1$ no consideration need be given to the latter expression. This value should be taken for the maximum connected synchronous capacity. (2) Multiply this current by the proper factors from Table 11. (3) The resulting interrupt-

ing and momentary currents should be used to select the circuit breaker.

The factors given in Table 11 represent the ratio between the rms total current at the instant of contact parting and the initial value of rms symmetrical current. In determining these factors it was assumed that circuit breakers should be installed which would permit the use of high-speed relays at some later date, and the time of contact parting was selected on this basis. Contact parting times of 4, 3, 2, and 1 cycles were assumed for 8-, 5-, 3-, and 2-cycle breakers.

Note that the total fault current calculated above may in some cases divide between two or more circuits. It is necessary to determine the maximum fault current that must be interrupted by each breaker under any circuit condition (see example).

For most apparatus and circuits the resistance may be neglected as a justifiable approximation. For underground cables and very light aerial lines the resistance may be as great as the reactance. For these elements the impedance should be used instead of the reactance. Unless it constitutes a major part of the total circuit impedance this impedance may be added arithmetically to the reactance of the rest of the circuit without appreciable error.

(b) **Overcurrent Protective Relays**—In approximating the settings of overcurrent relays, the fault currents for two conditions should be determined:

1. The maximum initial symmetrical current for maximum connected synchronous capacity as determined by E/X_1 or $3E/(2X_1 + X_0)$, whichever is greater, except that, when R_0 is greater than $2.23X_1$, no consideration need be given to the expression $3E/(2X_1 + X_0)$.

2. The minimum symmetrical current for minimum connected synchronous capacity as determined by $0.866E/X_1$, or $3E/(2X_1 + X_0)$ for reactance grounded systems. In particular situations, allowance should be made for remote fault locations and fault resistance.

Ground, distance, balanced, and other types of relays require special consideration.

For each of these conditions use machine impedances and multiplying factors in accordance with Table 12.

(c) **Example**—In order to illustrate the use of the above method of calculation, circuit breaker ratings for several locations in the system shown in Fig. 49 will be determined. The approximate impedance data references in Sec. 37 will be used.

From Table 4 of Chap. 6, Part XIII, the waterwheel gen-

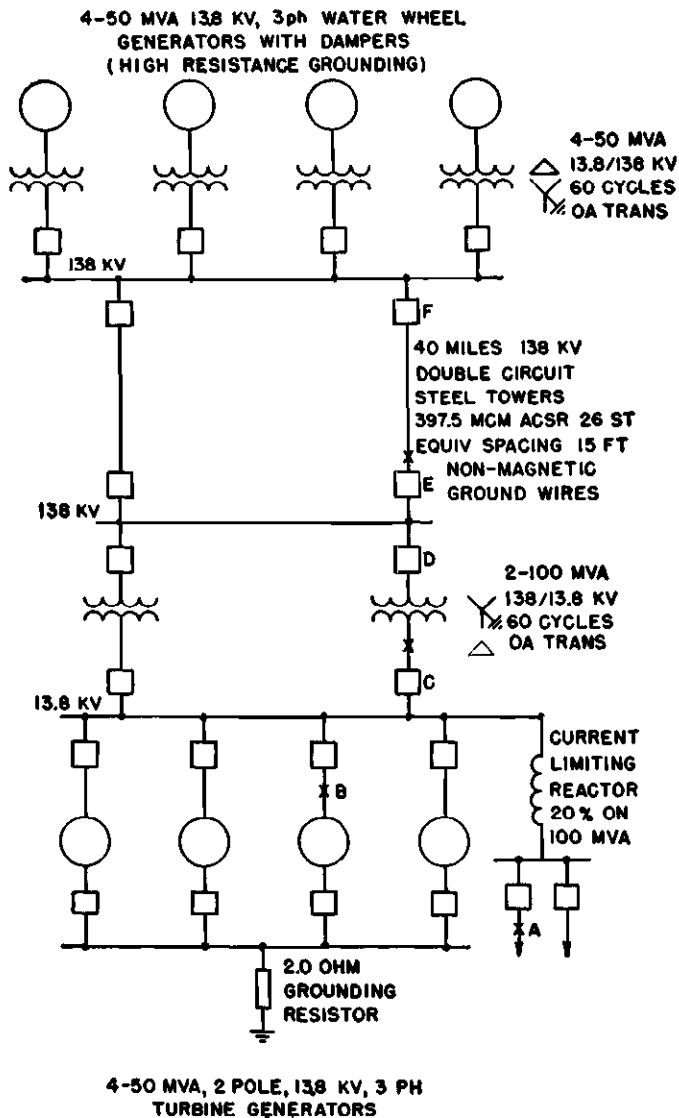

Fig. 49—Hypothetical system for example.

TABLE 12

Type of Relay	Use Following Reactance in Determining X_1			
	Multi- plying Factor	Synch. Gen. or Cond.	Synch. Motor	Induc- tion Machine
1. High-speed Current Actuated Relays.....	1.0	subtr.	subtr.	subtr.
2. Time Over-Current Relays..	1.0	trans.	trans.

erators would have a subtransient reactance of 24 percent on their own base. The 13.8-kv transformers would have an impedance of about 11 percent according to Table 1 of Chap. 5. The combined positive-sequence impedance of all four generators and transformers, viewed from the 138-kv bus is thus 35 percent on 200 mva or 17.5 percent on 100 mva. The zero-sequence impedance would be that of the transformers alone or 5.5 percent on 100 mva.

From Tables 2 and 6 of Chap. 3 each transmission circuit has a positive-sequence reactance of 0.77 ohms per mile. For the two 40 mile circuits in parallel the reactance is 8.1 percent on 100 mva. From Table 14 of this chapter the zero-sequence reactance may be estimated at 24.3 percent on 100 mva.

The 100-mva step-down transformers will also have an impedance of 11 percent on their kva rating or a net for the two of 5.5 percent on 100 mva.

The turbine-generators (see Table 4 of Chap. 6) will be taken as 9 percent each on 50 mva or a total of 4.5 percent on 100 mva for the four units.

The above impedances may be combined into the equivalent circuit shown in Fig. 50.

For a fault at A in Fig. 49 the 3-phase fault will govern breaker interrupting duty because of the limiting effect of

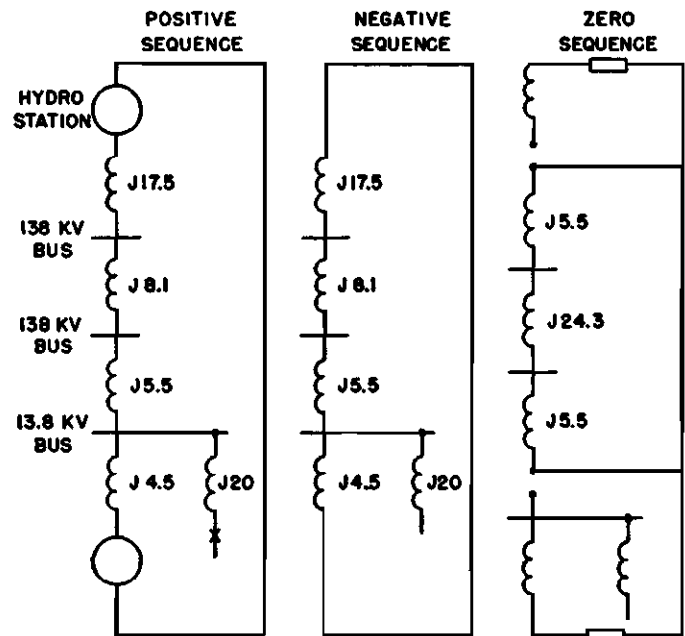

Fig. 50—Equivalent circuit for system of Fig. 49. Impedances in percent on 100 mva.

the generator grounding resistor and the delta-connected transformers. This fault is $\frac{1.0}{0.239} = 4.2$ per unit = 420 mva. Since this is less than 500 mva the general case of Table 11 applies and an 8-cycle breaker of 420 mva interrupting rating would be adequate. For normal interrupting duty (CO+15 seconds+CO) a standard 500-mva breaker could be chosen without further analysis since the calculated interrupting mva does not exceed 95 percent of the breaker rating.

If we desire to provide instantaneous single-shot reclosing on this feeder-breaker the interrupting current rating must be calculated. The interrupting rating of a 500-mva breaker at 13.8 kv is 21 000 amperes. According to Fig. 47 reclosing duty cycle II requires reduction of this rating to $21\ 000 \times 0.94 = 19\ 700$ amperes. The calculated fault level of 420 mva is equal to 17 600 amperes, so a standard 500-mva breaker would still be adequate. Regardless of the interrupting duty the momentary rating required would be $1.6 \times 17\ 600 = 28\ 200$ amperes.

For a fault at B, $\frac{E}{X_1} = \frac{1.0}{0.039} = 25.5$ per unit or 2550 mva. However, the portion of the fault contributed by generator B does not go through breaker B. This is $\frac{1.0}{0.18} = 5.5$ per unit or 550 mva. Thus $\frac{E}{X_1}$ for breaker B is 2000 mva. Since this value is greater than 500 mva and all standard 13.8-kv breakers have 8 cycle interrupting time, breaker B should have an interrupting rating of $1.1 \times 2000 = 2200$ mva. This is less than 95 percent of 2500 mva and a standard 2500-mva breaker may be chosen without further study.

A fault at C will give the highest fault current on any of the main 13.8-kv breakers. The three-phase fault will govern as before. Although it is an abnormal condition, the greatest fault current will flow when breaker D is open. For this condition X_1 is 4.0 percent and $\frac{E}{X_1} = 25.0$ per unit or 2500 mva. Since this fault is produced predominantly by the 13.8-kv turbine-generators the 1.1 multiplier is required for 8-cycle breakers and the duty exceeds that of the largest standard 13.8-kv breaker. In view of the close margin between the breaker rating and the calculated duty a more accurate check would be in order as suggested in Sec. 30. If such a check still indicated duty in excess of 2500 mva it would be necessary to increase the X_1 by modification of generator design or the addition of current-limiting reactors.

In order to determine the interrupting duty on the 138-kv breakers at the steam station it is necessary to consider both three-phase and single-line-to-ground faults as well as several fault locations and switching conditions. With all breakers closed $\frac{E}{X_1} = \frac{1.0}{0.0719} = 13.9$ per unit or 1390 mva

for a three-phase fault and $\frac{3E}{2X_1 + X_0} = \frac{3.0}{2(0.0719) + 0.0465} = 15.7$ per unit or 1570 mva for a line-to-ground fault. The current distribution for such a fault is shown in Fig. 51. The transformer and line circuits have been shown separately in order to study different fault locations. The smallest 138-kv breaker is rated 1500 mva and 5 cycles.

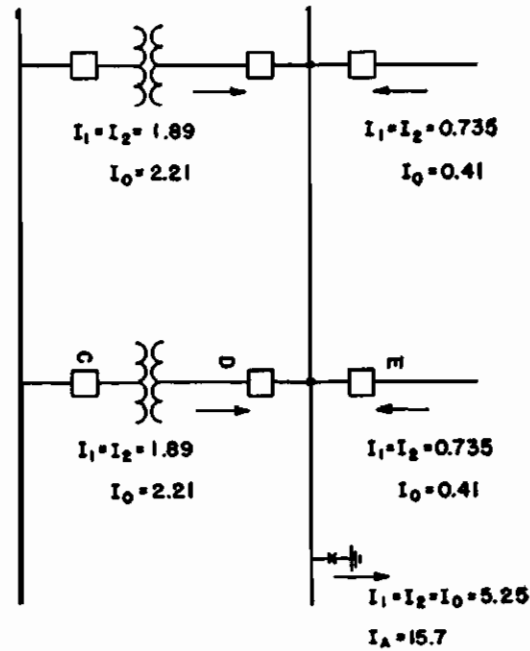

Fig. 51—Current distribution for a fault on 138-kv bus at steam station—currents in per unit on 100-mva base.

It is apparent that ground faults will govern interrupting duty.

A fault at D will produce the same fault currents but breaker D will carry $I_1 = I_2 = 3.36$ and $I_0 = 3.04$. $I_A = 9.76$ per unit. For such a fault the required interrupting duty for a 5 cycle breaker is $9.76 \times 1.1 = 10.7$ per unit or 1070 mva.

In order to be safe it is also necessary to consider a fault at D with breaker C open. See Fig. 52. The total fault now becomes $\frac{3.0}{0.0965 + 0.0965 + 0.0465} = 12.5$ per unit or 1250 mva but part of I_0 does not pass through breaker D. In the breaker $I_A = 4.16 + 4.16 + 2.40 = 10.72$. The re-

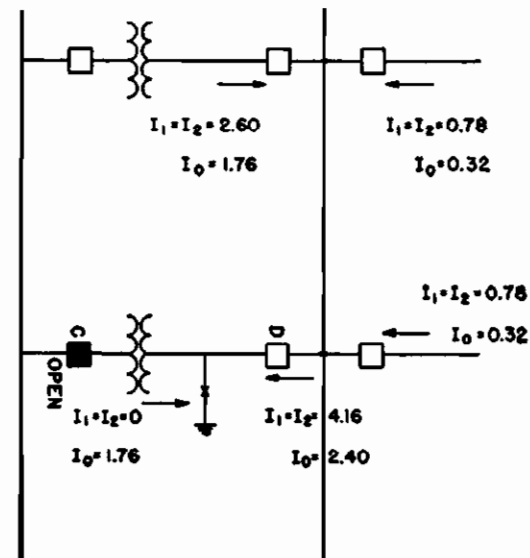

Fig. 52—Current distribution for single-line-to-ground fault at 138-kv terminals of transformer with 13.8-kv breaker open.

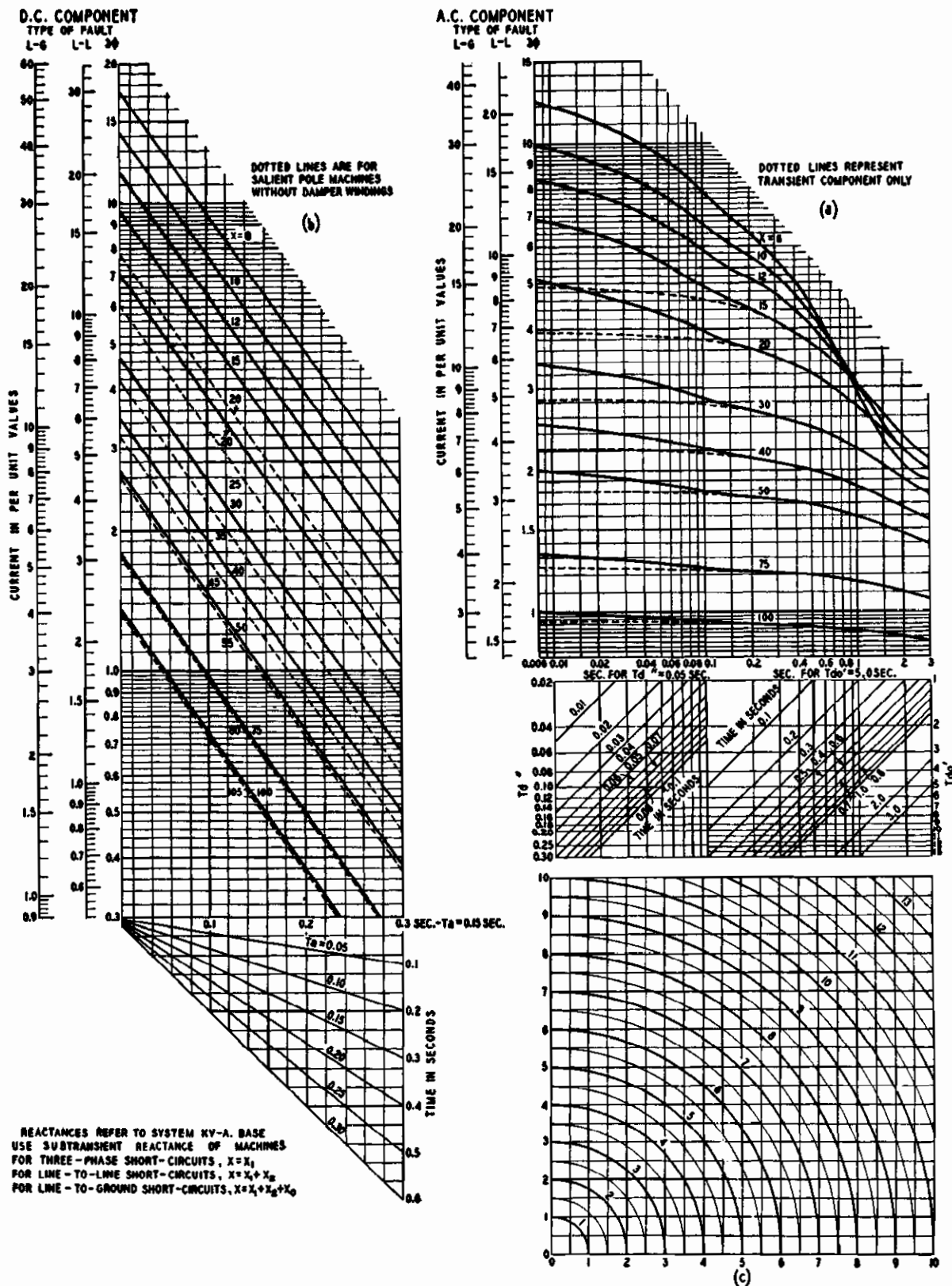

Fig. 53—Short-circuit decrement curves for similar parallel machines.

quired interrupting rating for this condition would be $1.1 \times 10.72 = 11.80$ per unit or 1180 mva which is greater than the value calculated in the previous study. Thus a 1500-mva breaker would be adequate for breaker *D* on the

basis of the system as shown. If additional generation or lines were contemplated the 1500 mva rating might be exceeded and such changes would have to be considered. Reclosing would not normally be used on these breakers

For breaker E a fault at E with all breakers closed required an interrupting rating of 1.1 (4.52+4.52+4.84) = 15.2 or 1520 mva. If breaker F were open such a fault would require an interrupting rating of

$$1.1 \frac{3.0}{0.077+0.077+0.05} = 16.1 \text{ per unit or } 1610 \text{ mva.}$$

Breaker E would probably have instantaneous single shot reclosing. A standard 1500-mva breaker would be good for only 1425 mva for such reclosing duty (see Fig. 47). Although it might be possible to reduce the interrupting duty of the system to 1425 mva by increasing the transformer impedance, a reasonable amount, some allowance should be made for future addition of generators or transmission lines. Thus a 3500-mva breaker would probably be chosen for the assumed system.

35. Short-Circuit Calculations for Similar Parallel Machines

It is intended that the simplified procedure given in Sec. 34 be used for normal circuit-breaker applications and for preliminary relay settings. In some special cases it may be desired to make a more accurate analysis of current decrement such as to take into account abnormal machine time constants or to obtain relay currents a relatively long time after the fault has occurred.

When all of the machines which contribute to a fault have similar reactances and time constants, are equally loaded, and are symmetrically located with respect to the fault the group of machines can be represented as a single equivalent generator. The fault current can then be calculated with relative accuracy by the methods described in Parts II, III and VI of Chap. 6 in which the effects of individual machine characteristics, loads, external impedance and change of excitation can be included.

A somewhat easier analysis may be made by the use of short-circuit decrement curves which have been published,^{117,118} and are reproduced in Fig. 53, if the assumptions on which they are based hold for the system under consideration. These are:

- Transient characteristics of alternating-current generators of normal design determined from oscillograph tests.
- That the effect of capacitance and resistance is neglected, except in so far as decrements are concerned, which effects are included by average decrement factors.
- That the contact resistance at short circuit is zero.
- That the alternating-current generators are carrying full load at 80 percent power factor previous to short circuit.
- That the short circuit is established at the point of voltage wave corresponding to the maximum possible instantaneous current.
- That the effect of automatic generator voltage regulators is neglected.
- All reactance up to and including 15 percent is considered within the generator. For values of reactance greater than that the difference is considered external.
- All machine emfs are assumed to be and remain in phase.
- The load is assumed to be located at the machine terminals and the fault to occur on an unloaded feeder.
- The actual system subjected to fault may be represented by a single equivalent generator of the same total rating as the synchronous apparatus of the system and an equivalent external reactance.

- All generators are assumed to have an open-circuit transient time constant (T'_{do}) of 5 seconds and an armature short-circuit time constant of 0.15 second.
- A subtransient time constant of 0.05 second was used for all curves.

The short-circuit current from a synchronous machine consists of an a-c and a d-c component. The a-c component in general can be resolved into a transient component having a relatively large time constant and a subtransient component having a relatively small time constant. The values of these constants are such that during the first one-tenth second the transient component changes very little, but the subtransient component disappears almost entirely. Because of this relation it is possible to plot the two a-c components on one set of curves as shown by the "a" curves of Fig. 53. The numbers of these curves refer to the combined external reactance (exclusive of loads) and machine subtransient reactance. A subtransient time constant of 0.05 and a transient open circuit time constant of 5.0 were used in the preparation of these curves, but the effect of other time constants can be included by reading vertically from the intersection of the horizontal line corresponding to the particular time constant and the inclined line corresponding to the particular time. The dotted lines show the transient component only of a-c current.

These curves are intended primarily for turbine-generator systems as indicated by assumption (g). The assumed relation between transient and subtransient reactance is $X'_d = (1.4X''_d + .02)$ per unit. The curves may be used with fair accuracy for salient pole generators with dampers. For salient pole machines without dampers the curves may be used with the following adjustments:

- Calculate the total system reactance to the point of fault using the *subtransient reactance* of the machines, and then *subtract 5 percent*.
- Enter the curves with the above modified value of reactance. (For example if the system reactance is 25 percent use the curve marked 20.)
- The proper a-c component of current will be approximately midway between the dotted and solid portions of the curves of 53(a) in the short time periods where a distinction is made.
- The proper d-c component of current is given by the dotted curves of 53(b).

With the above general qualifications the curves may be used to calculate three-phase, line-to-line or single-line-to-ground faults. The following symbols are used:

- X_1 = percent positive-sequence impedance viewed from the point of fault, based on the total synchronous kva.
 X_2 = negative-sequence impedance viewed from the point of fault.
 X_0 = zero-sequence impedance viewed from the point of fault.
 T_a = time constant of direct-current component.
 T'_d = short-circuit subtransient time constant.
 T'_{do} = open-circuit transient time constant.

For a three-phase fault use the curves of Fig. 53 (a) and (b) for which $X = X_1$ and read the components of current on the ordinate scales designated 3-phase. The a-c and d-c components may be combined into the rms total current for maximum asymmetry by the formula,

$$i_{\text{rms total}} = \sqrt{i_{a0}^2 + i_{d0}^2}.$$

Fig. 53(c) may be used to perform this calculation by laying off the components along the two axes and reading the rms total current on the circular scales.

A line-to-line fault is read in a similar manner except the curves are used for which $X = X_1 + X_2$ and the magnitude of current is read on the ordinate scale headed L-L.

For single-line-to-ground faults enter the curves with $X = X_1 + X_2 + X_0$ and use the ordinate scale headed L-G.

The curves of Fig. 53(b) are plotted against a basic time scale corresponding to $T_a = 0.15$ sec. If the d-c time constant is known to be different, read vertically from the intersection of the horizontal line corresponding to the desired time and the inclined line corresponding to the desired time constant.

36. The Internal Voltage Method

For critical relay and circuit-breaker applications where synchronous machines are dissimilar and unsymmetrically located with respect to the fault, a more accurate short-circuit analysis can be made by means of the *Internal Voltage Method*. This method lends itself to the use of a network calculator and can be used to include the effect of a change in the excitation of the machines. Because of the limited application of this method of calculation the reader is referred to a series of articles by C. F. Wagner, entitled "Decrement of Short-Circuit Currents," which appeared in the March, April, and May 1933, issues of the *Electric Journal*.

37. Approximate Impedance Data for Fault Calculations

In fault calculations, impedance data applicable specifically to the apparatus and circuits under consideration should be used whenever possible. Such data can usually be obtained from the manufacturers for existing apparatus and can be calculated with the aid of tables referred to below for overhead lines and cables. The necessity for accurate data is particularly important for circuit elements which have a major influence on the fault magnitude.

For estimating fault currents on proposed new circuits, and for approximate data on the less important elements of existing circuits, the following references and tables are offered as typical of present-day practice.

Synchronous Generators, Motors, and Condensers—Table 4 in Chap. 6 lists both average values and the probable range of the several impedances and time constants of 60-cycle three-phase synchronous machines. In most simplified fault calculations *subtransient* reactance is used to represent the positive-sequence impedance of synchronous machines, and its relation to the other impedances is assumed on the basis of typical designs. Exceptions to this assumption are noted in Sec. 34. The effect of external impedance on the time constants is discussed in Sec. 10 of Chap. 6.

Induction Motors—The effect of induction motors on the short-circuit current is discussed in Chap. 6.

Power and Distribution Transformers—Typical impedance values for distribution and power transformers are given in Table 1 of Chap. 5. The relation between the positive- and zero-sequence impedances for each of the principal types of transformers is also discussed in this

chapter and a table of equivalent circuits is given in the appendix.

Feeder Voltage Regulators—The impedance of single-phase induction regulators referred to the through kva of the circuit varies with regulator position from approximately 0.7 percent at maximum buck or boost position to approximately 2.5 percent at points midway between the neutral and maximum positions. At the neutral position the impedance is approximately 1.5 percent.

The impedance of polyphase induction regulators does not vary greatly with regulator position and lies between 1.0 percent and 1.5 percent on the circuit kva base.

For line voltages not exceeding the 15 kv insulation class level, single-core step regulators are used when the line current does not exceed 400 amperes. Two-core step regulators are used for higher current circuits to reduce the current handled by the tap changer to 400 amperes.

Two-core four-winding construction is used where the line voltage exceeds the normal 15 kv insulation class level.

The impedance of plus or minus 10 percent regulators in single-phase and balanced three-phase circuits is given in Table 13.

TABLE 13—IMPEDANCE OF FEEDER REGULATORS—PERCENT ON CIRCUIT KVA BASE—PLUS OR MINUS 10 PERCENT REGULATION

	Max.	Min.	Neutral Pos.
Induction			
Single-phase.....	2.5	0.7	1.5
Three-phase.....	1.5	1.0	...
Step-Type			
Single-core.....	0.4	0	...
Two-core, three-winding....	0.7	0.4	...
Two-core, four-winding....	1.1	0.5	...

Aerial Lines—The characteristics of aerial lines are given in Chap. 3.

When the conductor size and spacing of an aerial line cannot be determined and a rough value of impedance is known to be satisfactory, the reactance of lines above 15 kv class can be taken as 0.8 ohms per mile without serious error. The resistance of such lines will usually be negligible from the standpoint of circuit breaker and relay application. For lines rated 15 kv and below conductor size and spacing vary greatly and typical figures should not be used. If the actual line data cannot be obtained (and an approximate figure is known to be satisfactory) the conductor size and spacing may sometimes be estimated on the basis of thermal and regulation limits of the circuit.

The zero-sequence reactance of aerial lines can be estimated from the positive-sequence reactance by the use of Table 14. This approximation is sufficiently accurate for most circuit breaker applications, but when greater accuracy is required refer to Chap. 3 and other references given in that chapter.

Cables—The impedance of single- and three-conductor cables is given in Chap. 4.

The effect of iron conduit in increasing the reactance and resistance of cables has been investigated by L. Breiger of the Consolidated Edison Co. with both laboratory and field tests.¹²⁴ These tests show that if the cables are held

TABLE 14—APPROXIMATE RATIO OF X_0 TO X_1 FOR TRANSMISSION LINES AND CABLES

	Average	Range		Average	Range
Single-circuit Aerial Transmission Line (without ground wires or with magnetic ground wires).....	3.5	2.5-3.5	Double-circuit Aerial Transmission Line (with non-magnetic ground wires).....	3	2-4
Single-circuit Aerial Transmission Line (with non-magnetic ground wires).....	2	1.7-2.7	Three-phase Cables	...	3-5
			Single-phase Cables	1	...

in close triangular arrangement, the reactance is increased by only about 10 percent because of the iron conduit. In many cases, however, cables lie at random in the conduit and the reactance may be increased by as much as 50 percent.

For circuit breaker applications, in the absence of specific information, the reactance of iron conduit circuits may be taken at from 40 to 45 microhms per foot for one conductor per phase and 20 to 25 microhms per foot for two conductors per phase. For non-magnetic duct corresponding figures are 35 to 40 microhms per foot for one conductor per phase and 18 to 22 microhms per foot for two conductors per phase. The increase in resistance caused by the iron conduit is not sufficient to justify consideration in circuit breaker applications.

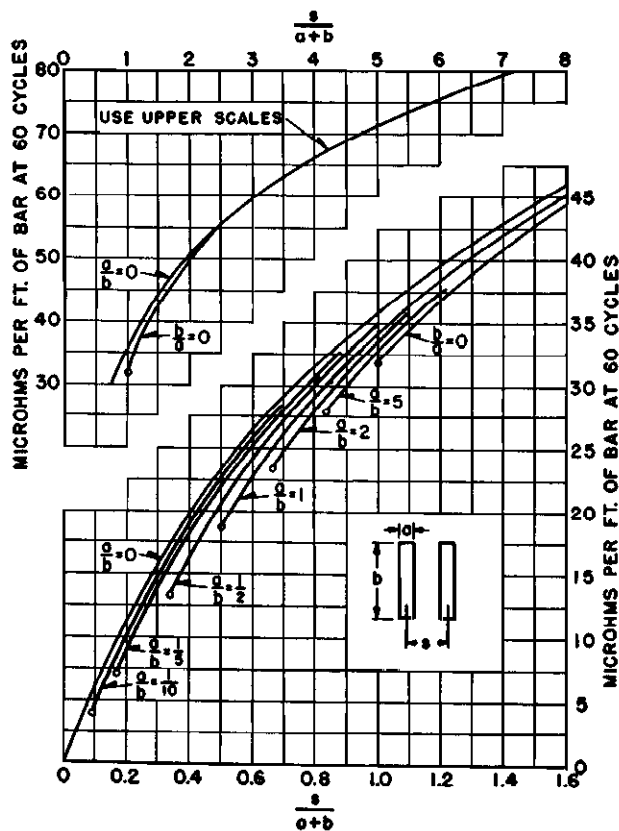

Fig. 54—Reactance of rectangular bar conductors.

Bus Conductors—The reactance of most busbar arrangements for low or medium voltage circuits is of the order of 50 microhms per foot. Values for practical circuits range from 30 to about 70 or 80 microhms. In low-voltage circuits bus reactance may be an appreciable part of the circuit impedance. For example 50 feet of bus at 50 microhms per foot will cause a drop of 50 volts at 20 000 amperes.

Fig. 54¹²⁶ gives the 60-cycle reactance per conductor per foot of two rectangular bars in a single phase circuit.

The reactance per phase of a transposed three-phase bus may also be obtained from Fig. 54 by replacing s by an equivalent spacing equal to the cube root of the product of the three distances between phase conductors. $s_{equiv.} = \sqrt[3]{s_1s_2s_3}$. If the bus is not transposed, the reactance corresponding to the minimum spacing should be used for circuit breaker applications in order to obtain the maximum current in any pole. For other applications it may be desirable to use the equivalent spacing in order to determine the average reactance per phase.

The reactance of bus runs composed of several closely spaced bars per phase may be determined approximately by considering each phase group as a solid conductor having the same overall dimensions. This approximation will give values of reactance accurate within about 5 percent if the distance s is more than twice the equivalent a . For the arrangement in Fig. 55 the error is 15 percent for $s = 8$ inch-

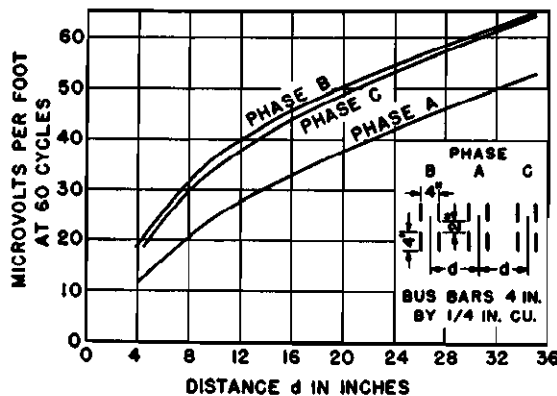

Fig. 55—Reactance voltage drop in each three-phase bus caused by one ampere of balanced three-phase current.

es and 6 percent for 30 inches. A more accurate method of calculation is given in Reference 126.

The reactance of irregularly shaped conductors can be determined from Figs. 56 and 57 and similar data published by bus bar manufacturers, such as References 131 to 133. A rough approximation may be obtained by the method described in the preceding paragraph.

Low-Voltage Air Circuit Breakers (600 Volts and Below)—The reactance of low-voltage air circuit breakers with series trip coils may be an appreciable part of the total circuit impedance when the full-load rating of the breaker is small compared with the remainder of the system. Care should be taken to make sure that trip coils are included on all three poles of a breaker before using the values in the accompanying table. If only two coils are used, one-third

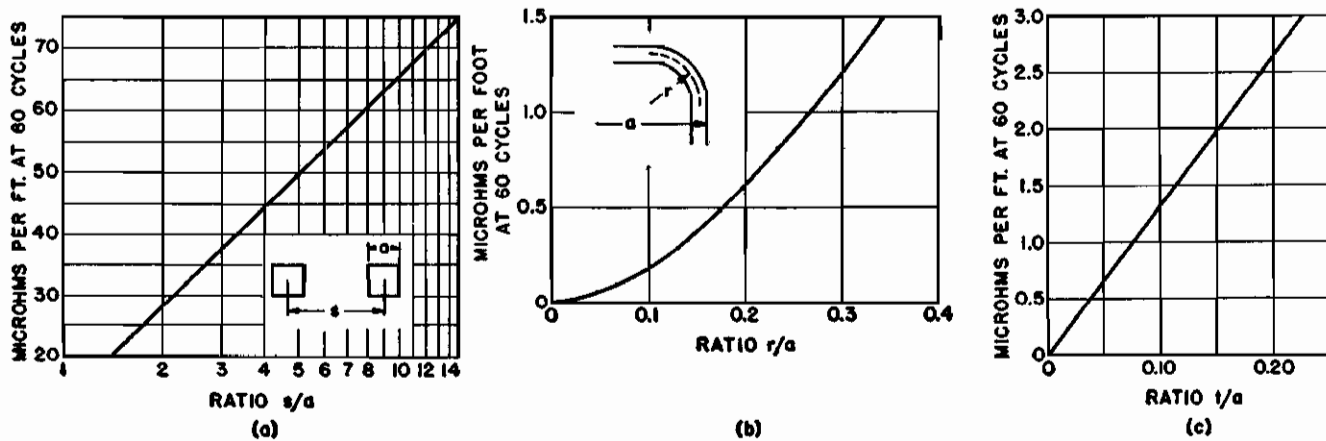

Fig. 56—Reactance of square tubular bus bars.

- (a) Reactance of thin square tubes.
- (b) Increase caused by round corners.
- (c) Increase caused by thickness of tubes.

of the single-coil impedance should be used in calculating the maximum pole current in a three-phase fault, and the impedance should be omitted entirely in calculating a single line-to-ground fault.

Values of series trip coil impedances are given in Table 15 for Westinghouse DA 50, DB 25, and DB 15 air circuit

breakers, which have interrupting ratings of 50 000, 25 000, and 15 000 amperes respectively at 600 volts or below.

The resistance per pole of AB-10 thermal breakers is given in Table 16.

The reactance of the main current-carrying loop of an air circuit breaker can not readily be separated from the influence of the bus or cable to which it is connected. It may be calculated along with the bus or neglected.

Current Transformers—The reactance of the smaller wound current transformers in a low-voltage circuit may be appreciable when fed from a relatively heavy supply

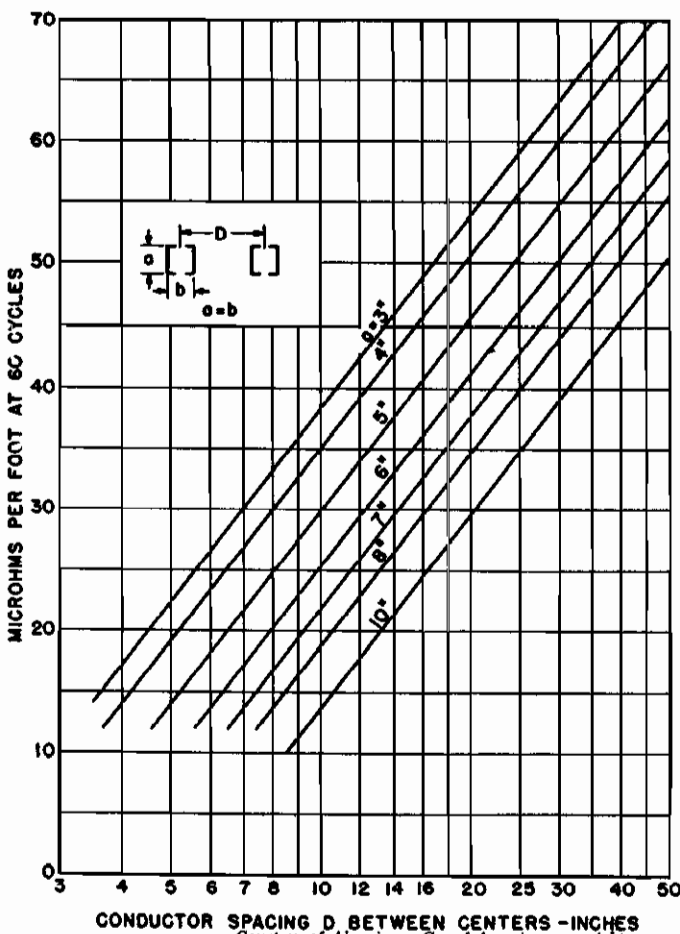

Fig. 57—Reactance of channel bus.

TABLE 15—D-C RESISTANCE AND 60-CYCLE REACTANCE OF 600 VOLT AIR CIRCUIT BREAKER SERIES TRIP COILS*

Full Load Ampere Rating	DA-50		DB-15 and DB-25	
	Resistance in ohms 25°C	Reactance in ohms	Resistance in ohms 25°C	Reactance in ohms
15	0.063	0.21	0.039	0.110
20	0.028	0.11	0.021	0.063
25	0.022	0.065	0.014	0.040
35	0.011	0.041	0.007	0.020
50	0.0042	0.015	0.0036	0.0090
70	0.0033	0.0080	0.0017	0.0053
90	0.0022	0.0063	0.0010	0.0034
100	0.0011	0.0039	0.00083	0.0025
125	0.00086	0.0030	0.00048	0.0017
150	0.00067	0.0023	0.00042	0.0013
175	0.00052	0.0017	0.00027	0.00088
200	0.00034	0.0012	0.00024	0.00072
225	0.00034	0.0012	0.00017	0.00057
250	0.00021	0.00076	0.00017	0.00057
350	0.00013	0.00043	0.000079	0.00033
400	0.00013	0.00043	0.000050	0.00023
500	0.000069	0.00019	0.000031	0.00017
600	0.000069	0.00019	0.000031	0.00017

*If only two series trip coils are used use 1/2 of these values in calculating a three-phase fault; neglect entirely for single-line-to-ground faults on three-phase circuits.

TABLE 16—RESISTANCE PER POLE OF AB-10 600-VOLT THERMAL CIRCUIT BREAKERS

600-AMPERE FRAME		225-AMPERE FRAME	
Full-Load Ampere Rating	Resistance in Ohms	Full-Load Ampere Rating	Resistance in Ohms
225	0.00024	50	0.00297
250	0.00022	70	0.00130
275	0.00018	90	0.00084
300	0.00016	100	0.00080
325	0.00014	125	0.00063
350	0.00012	150	0.00063
400	0.000096	175	0.00050
450	0.000078	200	0.00036
500	0.000064	225	0.00030
525	0.000060
550	0.000056
600	0.000048

100-AMPERE FRAME		50-AMPERE FRAME	
Full-Load Ampere Rating	Resistance in Ohms	Full-Load Ampere Rating	Resistance in Ohms
50	0.0036	15	0.0105
70	0.0025	20	0.0100
90	0.0018	25	0.0070
100	0.0015	35	0.0032
		50	0.0028

TABLE 17—IMPEDANCE OF CURRENT TRANSFORMERS

Westinghouse Type	Rated Current	Ohms	
		Impedance	Resistance
CT 2.5	50	0.008
	100	0.002
	200	0.0005
	400	0.00001
WE	200	0.0006	0.0003
	400	0.0002	0.00009
CT 5.0	50	0.014	0.008
	100	0.0035	0.002
	200	0.00095	0.0005
	400	0.00032	0.00015

circuit. Approximate values for specific Westinghouse current transformers are given in Table 17. The limiting effect of secondary burden has been neglected for the sake of simplicity.

REFERENCES

RELAYING

For a more complete Bibliography refer to *Silent Sentinels* or to the *Bibliographies of the Relay Literature* as follows: AIEE Relay Bibliographies.

Bibliography of Relay Literature, 1944-1946, AIEE Relay Committee. *A.I.E.E. Transactions*, Vol. 67, 1948, pages 24-7.

Bibliography of Relay Literature, 1940-1943, AIEE Relay Committee. *A.I.E.E. Transactions*, Vol. 63, 1944, October section, pages 705-09.

Bibliography of Relay Literature, 1927-1939, AIEE Relay Committee. *A.I.E.E. Transactions*, Vol. 60, 1941, pages 1435-47.

Books on Relaying

1. *Silent Sentinels* (a book), Westinghouse Electric Corporation 1949.
2. *Relay Systems, Theory and Application* (a book), by I. T. Monseth and P. H. Robinson, McGraw-Hill Book Co., Inc., 1935.

Bus and Apparatus Protection

11. *The Fault Ground Bus, Its Use and Design in Brunot Island Switch House of the Duquesne Light Co.*, by R. M. Stanley and F. C. Hornibrook, *A.I.E.E. Transactions*, Vol. 49, Jan. 1930, pages 201-212.
12. *Protecting Frequency Changers from Out-of-Step Conditions*, by L. N. Crichton, *The Electric Journal*, Vol. 34, Feb. 1937, pages 71-76.
13. *Relay Protection for Station Buses*, by W. A. Lewis and R. M. Smith, *The Electric Journal*, Vol. 34, Nov. 1937, pages 457-458.
14. *Harmonic Current-Restrained Relays for Differential Protection*, by L. F. Kennedy and C. D. Hayward, *A.I.E.E. Transactions*, Vol. 57, May 1938, pages 262-271.
15. *Relay Protection for a Large Regulating Transformer*, by W. C. Marter, *The Electric Journal*, Vol. 36, March 1939, pages 87-88.
16. *Bus Protection*, A.I.E.E.-E.E.I. Committee Report, *A.I.E.E. Transactions*, Vol. 58, May 1939, pages 206-211.
17. *Considerations in Applying Ratio Differential Relays for Bus Protection*, by R. M. Smith, W. K. Sonnemann and G. B. Dodds, *A.I.E.E. Transactions*, Vol. 58, June 1939, pages 243-252.
18. *Current Transformers and Relays for High-Speed Differential Protection*, with Particular Reference to Off-Set Transient Currents, by E. C. Wentz and W. K. Sonnemann, *A.I.E.E. Transactions*, Vol. 59, Aug. 1940, pages 481-488.
19. *A High Speed Differential Relay for Generator Protection*, by W. K. Sonnemann, *A.I.E.E. Transactions*, Vol. 59, Nov. 1940, pages 608-612.
20. *Prolonged Inrush Currents with Parallel Transformers Affect Differential Relaying*, by C. D. Hayward. A.I.E.E. Technical Paper 41-65.
21. *Linear Couplers for Bus Protection*, by E. L. Harder, E. C. Wentz, W. K. Sonnemann, E. H. Klemmer. A paper presented at the A.I.E.E. Winter Convention, Jan. 1942.
22. *Predicting Performance of Bus Differential Systems*, by E. C. Wentz and W. K. Sonnemann, *Westinghouse Engineer*, Feb. 1942, page 28.
23. *The Effect of Direct Current in Transformer Windings*, by E. L. Harder, *Electric Journal*, Vol. 27, Oct. 1930, page 601.
24. *Bus Protection Independent of Current Transformer Characteristics*, by G. Steeb, A.I.E.E. Technical Paper No. 41-99.
25. *System Protection Analysis Precedes Oswego Design*, by G. Steeb, *Electrical World*, Vol. 116, Nov. 1, 1941, page 57.
26. *Vibration Protection for Rotating Machinery*, R. L. Webb, C. S. Murray. *A.I.E.E. Transactions*, Vol. 63, July 1944, pages 534-7.
27. *Linear Couplers. Field Test and Experience at York and Middletown, Pa.*, E. L. Harder, E. H. Klemmer and R. E. Neidig. *A.I.E.E. Transactions*, Vol. 65, Mar. 1946, pages 107-13.
28. *Motoring Protection for A-C Generators*, L. L. Fountain. *Westinghouse Engineer*, Vol. 6, November 1946, pages 190-91.
29. *Relay Protection of Power Transformers*, A.I.E.E. Relay Committee. *A.I.E.E. Transactions*, Vol. 66, 1947, pages 911-15.

30. Recommended Practices for the Protection of Electrical Apparatus, A.I.E.E. Relay Subcommittee. *A.I.E.E. Transactions*, Vol. 52, 1933, pages 607-13.
- 30.1 Relay Protection for Large Regulating Transformers, W. E. Marter. *Electric Journal*, Vol. 36, March 1939, pages 87-8.
- 30.2 Current Transformer Excitation under Transient Conditions, D. E. Marshall, P. O. Langguth, *A.I.E.E. Transactions*, Vol. 48, 1929, pages 1464-74.

Transmission Line Protection (except carrier and pilot wire)

31. High-Speed Relays Increase System Stability, by S. L. Goldsborough, *The Electric Journal*, Vol. 27, July 1930, pages 400-401.
32. Fundamental Basis for Distance Relaying on Three-Phase Systems, by W. A. Lewis and L. S. Tippet. *A.I.E.E. Transactions*, Vol. 66, 1947, pages 694-709.
33. A New High-Speed Distance Relay, by S. L. Goldsborough and W. A. Lewis, A.I.E.E. Paper 32M1, Presented Winter Convention, Jan. 26, 1932. Abstract, *Electrical Engineering*, Vol. 51, March 1932, pages 157-160.
34. High Speed Distance Relay (Type HCZ Relay), by L. N. Crichton, *The Electric Journal*, Vol. 32, Dec. 1935, pages 537-542.
35. A New Distance Ground Relay, by S. L. Goldsborough and R. M. Smith, *A.I.E.E. Transactions*, Vol. 55, June 1936, pages 607-703; Disc. Vol. 55, Nov. 1936, pages 1255-1256.
36. High-Speed Balanced-Current Relays for Parallel Lines, by S. C. Leyland, *The Electric Journal*, Vol. 33, Aug. 1936, pages 347-350.
37. A System Out-of-Step and Its Relay Requirements, L. N. Crichton, *A.I.E.E. Transactions*, Vol. 56, Oct. 1937, pages 1261-1267; Disc. Vol. 57, May 1938, pages 284-286.
38. High-Speed Relaying Experience and Practice, A.I.E.E. Committee Report, *A.I.E.E. Transactions*, Vol. 58, Nov. 1939, pages 588-592.
39. Out-of-Step Blocking and Selective Tripping with Impedance Relays, by H. R. Vaughan and E. C. Sawyer, *A.I.E.E. Transactions*, Vol. 58, Dec. 1939, pages 637-646.
40. An Improved Polyphase Directional Relay, by Bert V. Hoard, A.I.E.E. Paper 41-62.
41. A Distance Relay with Adjustable Phase Angle Discrimination. S. L. Goldsborough. *A.I.E.E. Transactions*, Vol. 63, 1944, pages 835-838.

Carrier-Current Relaying

51. One Cycle Carrier Relaying Accomplished, by P. Sporn and C. A. Muller, *Electrical World*, Vol. 105, Oct. 12, 1935, pages 26-28.
52. A Faster Carrier Pilot Relay System, by O. C. Traver and E. H. Bancker, *A.I.E.E. Transactions*, Vol. 55, June 1936, pages 689-696; Disc. Vol. 55, Nov. 1936, pages 1252-1254.
53. Carrier Relaying and Rapid Reclosing at 110 Kv, by R. E. Pierce, R. E. Powers, E. C. Stewart and G. E. Heberlein, *A.I.E.E. Transactions*, Vol. 55, Oct. 1936, pages 1120-1129.
54. A New High-Speed Distance-Type Carrier Pilot Relay System, by E. L. Harder, B. E. Lenahan and S. L. Goldsborough, *A.I.E.E. Transactions*, Vol. 57, Jan. 1938, pages 5-10; Disc. Vol. 57, May 1938, pages 291-294.
55. A New Carrier Relay System, T. R. Halman, S. L. Goldsborough, H. W. Lensner, A. F. Drompp. *A.I.E.E. Transactions*, Vol. 63, 1944, August issue, pages 568-72.

Pilot-Wire Relaying

61. D-C Pilot-Wire Loop Protects 66 Kv. Cable Circuits, by J. H. Neher, *Electrical World*, Vol. 101, Mar. 25, 1933, pages 384-387.
62. A Single-Element Differential Pilot Wire Relay System, by

E. L. Harder and M. A. Bostwick, *The Electric Journal*, Vol. 35, Nov. 1938, pages 443-448.

63. Ratio Differential Protection of Transmission Lines, by R. M. Smith and M. A. Bostwick, A.I.E.E. Technical Paper, No. 39-154, Aug. 1939.
64. An Improved A-C Pilot Wire Relay, by J. H. Neher and A. J. McConnell, A.I.E.E. Technical Paper, No. 40-127, July 1940.
65. Pilot Wire Circuits for Protective Relaying—Experience and Practice, A.I.E.E. Relay Committee. *A.I.E.E. Transactions*, Vol. 62, May 1943, pages 210-14.
66. Protection of Pilot Wire Circuits, E. L. Harder, M. A. Bostwick. *A.I.E.E. Transactions*, Vol. 61, September 1942, pages 645-51.
67. Protection of Pilot Wires from Induced Potentials, R. B. Killen, G. G. Law. *A.I.E.E. Transactions*, Vol. 65, 1946, May section, pages 267-70.

Instrument Transformers

71. Current Transformer Excitation Under Transient Conditions, by D. E. Marshall and P. O. Langguth, *A.I.E.E. Transactions*, Vol. 48, Oct. 1929, pages 1464-1474.
72. What the Tests Show (Refers to Indianapolis Tests on Breakers, Relays and Potential Devices), by P. O. Langguth and R. M. Smith, *The Electric Journal*, Vol. 30, March 1933, pages 98-101.
73. Capacitor Potential Devices, by P. O. Langguth, *The Electric Journal*, Vol. 31, March 1934, pages 107-109, 112.
74. Overcurrent Performance of Bushing Type Current Transformers, by C. A. Woods, Jr. and S. A. Bottonari, *A.I.E.E. Transactions*, Vol. 59, Sept. 1940, pages 554-560.
75. Transient and Steady State Performance of Potential Devices, by E. L. Harder, P. O. Langguth and C. A. Woods, Jr., *A.I.E.E. Transactions*, Vol. 59, Feb. 1940, Pages 91-102.
76. Rating of Potential Devices and Suggested Material for a Standard, by J. E. Clem and P. O. Langguth, A.I.E.E. Technical Paper, No. 40-94, June 1940.

General Relaying

81. Building a New Power System, by F. S. Douglass and A. C. Monteith, *The Electric Journal*, Vol. 30, Feb. 1933, pages 55-59.
82. Planned Protective System, by A. C. Monteith and W. A. Lewis, *Electrical World*, Vol. 106, Nov. 21, 1936, pages 40-42.
83. Coordination of Fuse Links, Method of Comparing Fuse Links and Relays for Sectionalization and Protection, by E. M. Adkins, *Electrical World*, Vol. 107, March 13, 1937, pages 877, 952.
84. Pennsylvania Railroad New York-Washington-Harrisburg Electrification-Relay Protection of Power Supply System, by E. L. Harder, *A.I.E.E. Transactions*, Vol. 58, June 1939, pages 266-276.
85. Sensitive Ground Protection for Radial Distribution Feeders, by L. F. Hunt, and J. H. Vivian, *A.I.E.E. Transactions*, Vol. 59, Feb. 1940, pages 84-90.
86. Factors Contributing to Improving Electric Service by Means of High-Speed Switching and Utilization of Stored Energy, by J. T. Logan and John H. Miles, *A.I.E.E. Transactions*, 1941, page 1012.
87. Principles and Practices of Relaying in the United States, by E. L. Harder and W. E. Marter. *A.I.E.E. Transactions*, 1948, pages 1005-22.
88. Protection of Power House Auxiliaries, A.I.E.E. Relay Committee. *A.I.E.E. Transactions*, Vol. 65, 1946, pages 746-751, Disc. pages 1115-1116.
89. Protection of Three-Terminal Lines. M. A. Bostwick, E. L. Harder. *Westinghouse Engineer*, Aug. 1943, pages 76-79.
90. Interim Report on Operation and Application of Out-of-Step Protection. A.I.E.E. Relay Committee. *A.I.E.E. Transactions*, Vol. 62, Sept. 1943, pages 567-73.

91. Nine Year's Experience with Ultrahigh-Speed Reclosing of High-Voltage Transmission Lines, Philip Sporn, C. A. Muller. *A.I.E.E. Transactions*, Vol. 64, 1945, May section, pages 225-8.
92. High-Speed Single-Pole Reclosing, J. J. Trainor, J. E. Hobson, H. N. Muller, Jr. *A.I.E.E. Transactions*, Vol. 61, February 1942, pages 81-7.
93. Grounding of Instrument-Transformer Secondary Circuits, A.I.E.E. Relay Subcommittee, *A.I.E.E. Transactions*, Vol. 66, 1947, pages 419-20.
94. High-Speed Relaying Experience and Practice. A.I.E.E. Relay Committee, *A.I.E.E. Transactions*, Vol. 53, 1939, pages 588-91.

CIRCUIT BREAKERS

100. A Brief Review of Switchgear and Circuit Breaker Practice in the United States, by M. H. Hobbs, *A.I.E.E. Transactions*, Vol. 67, Part II, page 893.
101. The Interruption of Charging Current at High Voltage, by W. M. Leeds and R. C. Van Sickle, *A.I.E.E. Transactions*, 1947.
102. The 13,500 KVAR Static Capacitor Installation at Newport News, by E. L. Harder and V. R. Parrick, *A.I.E.E. Transactions*, 1944.
103. Power Circuit Breaker Ratings, by R. C. Van Sickle, *A.I.E.E. Transactions*, Vol. 60, page 882.
104. Surge Protection of Cable Connected Equipment, by R. L. Witzke and T. J. Bliss, A.I.E.E. Paper 50-83.
105. American Standards for Alternating-Current Power Circuit Breakers, C37.4 and C37.5-1945, C37.6-1949, C37.7 and C37.8-1945, C37.9-1945.
106. Report on Guiding Principles for the Specification of Service Conditions in Electrical Standards, A.I.E.E. No. 1B, 1944.
107. Air Circuit Breakers, A.I.E.E. No. 20, 1930.
108. Low-Voltage Air Circuit Breakers, Proposed A.I.E.E. No. 20A, 1946.
109. Power Circuit Breaker Standards, NEMA 46-116.
110. Large Air Circuit Breaker Standards, NEMA 46-109.
111. Standard for Branch-Circuit and Service Circuit Breakers, Underwriters Laboratories No. 489.
112. Standards for Switchgear Assemblies, A.I.E.E. No. 27, 1942. NEMA No. 44-92.
113. Power Switchgear Assemblies Standards.

FAULT CALCULATIONS

114. System Short-Circuit Currents by W. M. Hanna, H. A. Travers, C. F. Wagner, C. A. Woodrow, and W. F. Skeats, *A.I.E.E. Transactions*, Vol. 60, page 877.
115. New Fault-Current-Calculating Procedure Recommended to Industry, *Electrical Engineering*, Vol. 60, page 596.
116. Simplified Calculation of Fault Currents, an A.I.E.E. Committee Report, *Electrical Engineering*, November 1948.
117. Standard Decrement Curves, By W. C. Hahn and C. F. Wagner, *A.I.E.E. Transactions*, Vol. 51, 1932, page 353.
118. Decrement of Short-Circuit Currents, by C. F. Wagner, *Electric Journal*, March, April and May 1933.
119. Symmetrical Components, by C. F. Wagner and R. D. Evans (a book) McGraw-Hill Book Company, 1933.
120. Sequence Network Connections for Unbalanced Load and Fault Conditions, by E. L. Harder, *Electric Journal*, Vol. 34, Dec. 1937.
121. Thevenin's Theorem, by E. L. Harder, *Electric Journal*, Vol. 35, Oct. 1938.
122. Calculation of Fault Current in Industrial Plants, by Raymond C. R. Schulze, *Electrical Engineering*, June 1941.
123. Enclosed Bus-Bar Electrical Distribution Systems for Industrial Plants, by E. T. Carlson, *A.I.E.E. Transactions*, Vol. 60, page 297.
124. Impedance of Three-Phase Secondary Mains in Nonmetallic and Iron Conduits, by L. Brieger, *EEI Bulletin*, Feb. 1938.
125. Formulas and Tables for the Calculation of Self and Mutual Inductance, by E. B. Rosa and F. W. Grover, Scientific Paper No. 169, Bureau of Standards.
126. Reactance Values for Rectangular Conductors, by H. B. Dwight, *Electric Journal*, June 1919.
127. Inductance and Reactance of Rectangular Bar Conductors, by O. R. Schurig, *General Electric Review*, May 1933.
128. Calculations of Inductance and Current Distribution in Low-Voltage Connections to Electric Furnaces, by C. C. Levy, *A.I.E.E. Transactions*, Vol. 51, page 903.
129. Current Carrying Capacity of Bare Conductors, by H. W. Papst, *Electrical World*, Sept. 21, 1929.
130. Reactance of Square Tubular Busbars, by H. B. Dwight and T. K. Wang, *A.I.E.E. Transactions*, Vol. 57, page 762.
131. Alcoa Aluminum Bus Conductors, Aluminum Company of America.
132. Chase Electrical Handbook, Chase Brass and Copper Company.
133. Anaconda Copper Bus Conductors, Publication C-25.

POWER-LINE CARRIER APPLICATION

Author:

R. C. Cheek

I. INTRODUCTION

CARRIER equipment has been used on the power systems of this country since the early 1920s. At first, carrier was used for voice communication only, but its applications subsequently expanded to include a wide variety of functions such as protective relaying, telemetering, supervisory control, and others. Today, carrier is indispensable to the operation of most power systems. Power-line carrier offers rapid and dependable communication for interoffice business and for load dispatching. Carrier relaying permits high-speed clearing of all types of faults, with an attendant increase in stability limits and permissible line loading. Carrier provides economical channels for the telemetering of continuous load information to dispatchers for efficient system operation. Carrier channels are used for the remote supervision and control of many important substations and for automatic load control of numerous large generating units.

The application of carrier equipment for the transmission of high-frequency signals over a 60-cycle power transmission system involves many problems that most communication engineers do not have to face. The configuration and layout of these systems is invariably dictated by 60-cycle considerations, and short taps and spur lines that can play havoc with carrier-frequency transmission are included without regard to their effect upon such high frequencies. The power system communications engineer must nevertheless take the 60-cycle system as it exists and make the carrier equipment operate satisfactorily between the required points, drawing heavily upon his experience and ingenuity to stay within his usually limited budget.

The process of applying carrier to power lines is still largely empirical, because the complexity of the usual power system makes the exact calculation of all the effects practically impossible. However, an appreciation of the fundamental principles involved and the use of the practical data that have been gathered through the years usually permit the characteristics of a proposed carrier channel to be predicted with adequate accuracy.

In this chapter, a review of the major applications of power-line carrier is followed by discussion of some of the fundamental considerations in the transmission of high-frequency energy over power systems. The remainder of the chapter provides data on the practical application of power-line carrier channels.

1. Carrier Frequencies

For many years the band of frequencies from 50 to 150 kilocycles was considered the normal carrier band. How-

ever, the greatly increased application of carrier equipment of the past decade has resulted in virtual saturation of this band on most interconnected power systems, and many new channels have been established at frequencies as high as 200 kc and as low as 30 kc. The practical limits to extension of the frequency band will probably be established by excessive losses at the high-frequency end of the spectrum, and by the bulkiness and complexity of coupling and tuning equipment and the difficulty of obtaining sufficiently broad tuned circuits at the lower-frequency end.

II. CARRIER APPLICATIONS

2. Carrier Communication^{1,2,3,8}

Power-line carrier communication systems differ in the method of calling, the power supply, or in the modulation system, but any given assembly can be classified as simplex or duplex, depending upon its operation.

A *simplex* system is one in which transmission can proceed from one station only at any given instant. In simplex communication all stations on a channel operate on a single frequency. Transmission and reception cannot take place simultaneously on the same frequency at one station, because the transmitter blocks the local receiver and may even damage it permanently unless the receiver is de-energized during transmission periods. The simplex system therefore requires means for turning off the receiver and energizing the transmitter during transmission.

Requiring only a single carrier frequency, simplex equipment lends itself readily to applications in extensive carrier-communication systems involving more than two terminals. It is economical of space in the carrier-frequency spectrum because the same frequency is used at all transmitting points. Crowding of the spectrum is a serious problem on many power systems today, and this factor alone is often sufficient to justify its application.

A *duplex* system is one in which transmission can take place simultaneously from both stations, as in ordinary telephone service. In the duplex system, the first of two frequencies is used for transmission at one station, the second for reception. At the other station, the first frequency is used for reception, the second for transmission.

Duplex operation normally is limited to two terminals per channel, unless communication is desired between a central office and several other stations not requiring intercommunication. Its major advantage, one that in the minds of some users outweighs any disadvantages, is its ability to provide two-way conversation without the switching operations required by the simplex system.

3. The Single-Frequency Manual-Simplex System

In the single-frequency manual-simplex system, shown diagrammatically in Fig. 1, "send-receive" switching operations are performed by the speaker with a pushbutton on the telephone handset. Although provision can be made for complete operation over a two-wire extension, a control circuit separate from the speech circuits generally is re-

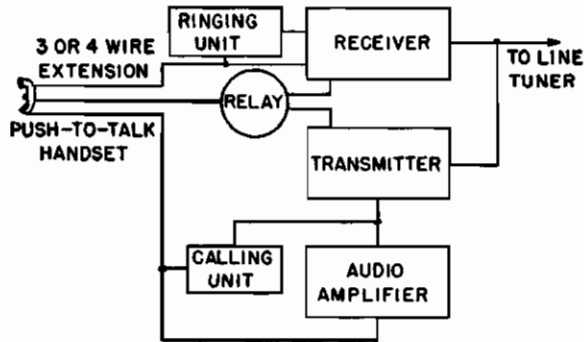

Fig. 1—Basic units of manual simplex communication assembly with code-bell calling.

quired. The need for d-c control circuits and the fact that a special telephone instrument with a "push-to-talk" button is necessary preclude any simple method of extending a manual-simplex telephone channel through a conventional private-branch-exchange board.

This system is the simplest of the carrier-communication systems in terms of the amount of equipment required and in ease of adjustment after installation. For dispatching and other applications where users are accustomed to handling push-to-talk handsets, it is an entirely adequate system.

4. The Two-Frequency Duplex System

The basic units of a two-frequency duplex assembly are shown in Fig. 2. A photograph of a typical complete

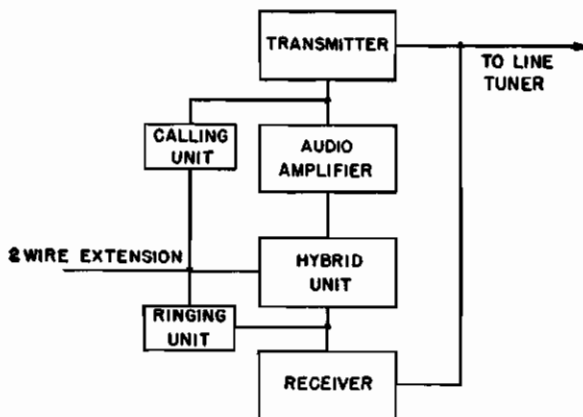

Fig. 2—Basic units of two-frequency duplex communication assembly with code-bell calling.

assembly is given in Fig. 3. Aside from the fact that the transmitter and receiver operate on different frequencies, the most important difference between this system and the manual simplex system is the addition of the audio hybrid

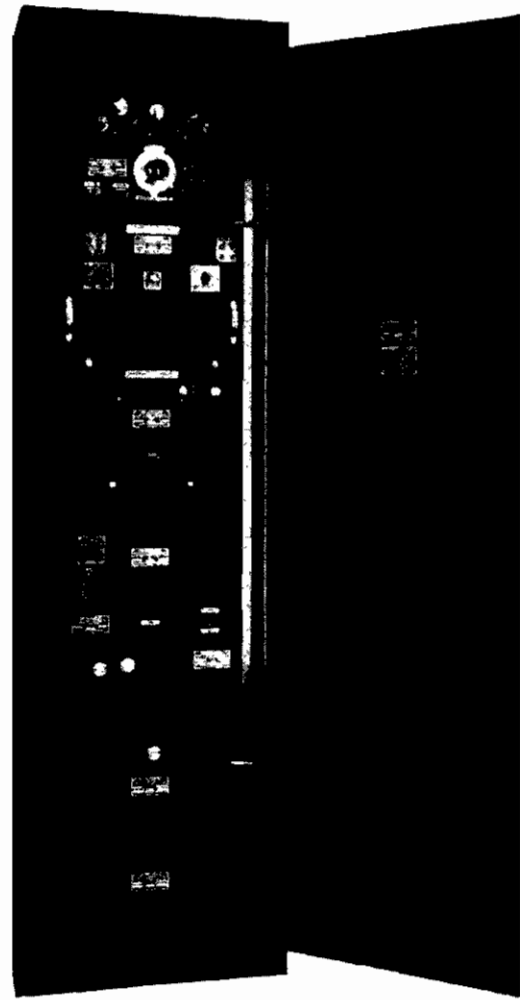

Fig. 3—Typical two-frequency duplex assembly. Panel units, top to bottom, are transmitter, audio amplifier, blank test-meter unit, superheterodyne receiver, audio hybrid and signalling units, switch and fuse unit, high-voltage power supply, low-voltage power supply, and voltage-adjusting autotransformer unit.

unit. It is this unit that makes it possible for the transmitter and the receiver to operate continuously during the conversation, without switching operations, with a conventional two-wire telephone extension.

The purpose of the hybrid unit can best be understood by considering what would happen to a two-frequency duplex channel if an attempt were made to operate into two-wire telephone extensions at each end without hybrid units. With such a system, the audio output of the receiver would be connected directly to the input terminals of the audio amplifier and would modulate the transmitter output. This signal would be received at the distant station, amplified by the audio amplifier, and transmitted back to the first station, where it would be amplified again and retransmitted. An oscillatory circuit would thus exist, and the outputs of the receivers at both stations would be an audio howl of a frequency equal to the natural frequency of the complete loop. This howl would make the circuit useless for communication purposes.

The audio hybrid unit prevents this howl by reducing the

amount of receiver output that reaches the audio amplifier input terminals to a value insufficient for continuous oscillation. The unit contains a three-winding transformer connected between the telephone line and the transmitter and receiver terminals as shown in Fig. 4. The balancing network must be a group of resistors, capacitors, and inductors connected in a network whose impedance matches

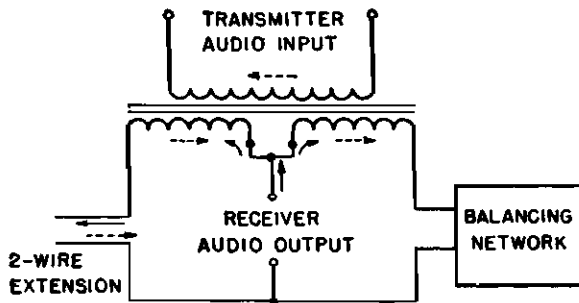

Fig. 4—Typical hybrid coil and connections. The components of the balancing network are chosen to match the input impedance of the telephone extension as nearly as possible over the voice-frequency band.

closely the impedance of the telephone line and associated equipment, as viewed from the hybrid unit terminals, over the band of audio frequencies transmitted by the carrier equipment. Examination of Fig. 4 shows how a typical hybrid transformer is intended to accomplish its function of placing the signal from the receiver upon the telephone line without producing a corresponding signal voltage across the input terminals of the transmitter audio amplifier. The receiver output is fed into the hybrid transformer at the junction of two identical windings. These two windings are in series with identical impedances, so that the receiver output current divides equally between the two. The ampere turns in the two windings balance or neutralize each other, leaving no ampere turns to be balanced by current in the third winding. The voltage across this third winding is therefore theoretically zero as far as the effect of signals from the receiver is concerned.

For a signal from the telephone line, however, the currents in the two identical windings are in essentially the same direction, some flowing through the receiver output transformer and the remainder flowing through the balancing network. A corresponding voltage therefore appears across the terminals of the third winding.

It is essential that telephone extensions used with duplex assemblies be properly terminated and be free of discontinuities. Received signals transmitted along an extension and reflected from such discontinuities back toward the carrier set appear to the hybrid unit as normal signals to be transmitted and may make it impossible to achieve a satisfactory balance with any type of balancing network.

The determination of the proper balancing network and the adjustment of audio levels after installation are usually the major problems in the application of two-frequency duplex equipment.

5. The Multi-Station Duplex System

The multi-station duplex system provides the advantages of duplex communication between any two of a num-

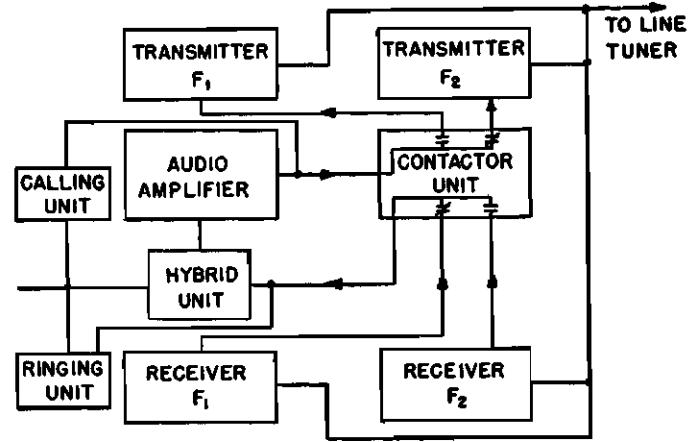

Fig. 5—Basic units of multi-station two-frequency duplex communication assembly with code-bell calling.

ber of stations on a channel. The basic units are shown in Fig. 5. Two transmitters and two receivers are included in each assembly, but other units, such as power supplies and amplifiers, are not duplicated.

The transmitter and receiver used at a given station depend upon the point of origin of the call. Designating the two frequencies as F_1 and F_2 , for example, all stations would normally receive on F_1 . A station originating a call, however, transmits on F_1 . The F_1 transmitter is selected by the calling party by the simple act of picking up the telephone handset. The closing of the d-c circuit through the hook switch operates a relay, which causes the contactor unit to apply the output of the audio amplifier to the audio terminals of transmitter F_1 . Simultaneously the contactor unit energizes the transmitter and applies the output of receiver F_2 to the audio hybrid unit. At the called station, the reception of the carrier signal from the calling station on receiver F_1 operates a relay whose contacts open to prevent the transfer from transmitter F_2 to transmitter F_1 from being made by the contactor unit when the called party replies. Transmitter F_1 and receiver F_2 at the calling station and transmitter F_2 and receiver F_1 at the called station remain energized throughout the conversation. When the conversation is completed, the hanging up of the telephones at both stations returns conditions to normal, with all stations receiving on F_1 .

6. The Single-Frequency, Automatic-Simplex System

Single-frequency automatic simplex is the most versatile of all the power-line carrier-communication systems. The number of stations on a given channel is not limited to two, as is the case with the usual two-frequency duplex system; it permits a single conversation among several stations on the channel, and it permits operation with two-wire telephone extensions and through PBX boards without requiring balance of a hybrid unit.

Modern automatic-simplex equipment eliminates objections to "send-receive" switching because this function, accomplished automatically, is so rapid and quiet that the user often is unable to detect its occurrence. In up-to-date automatic-simplex equipment, the transfer is made so

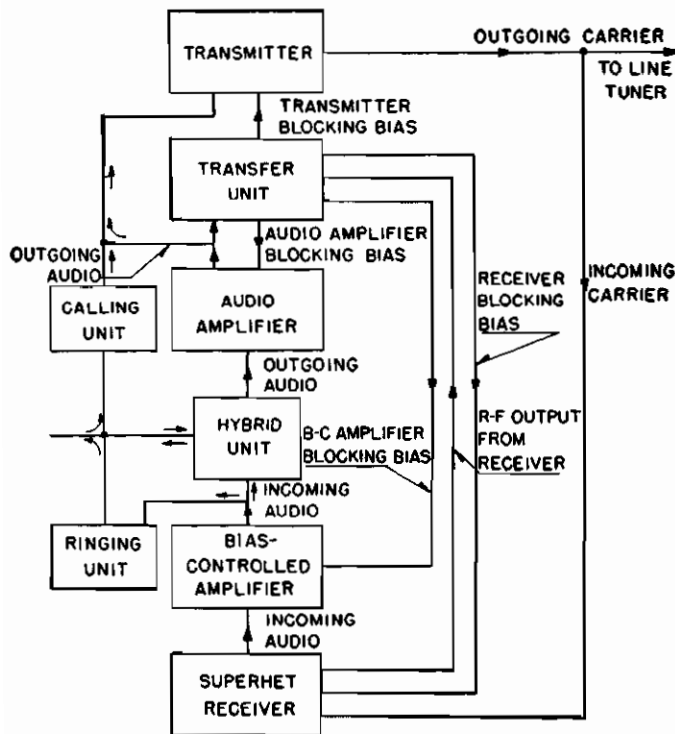

Fig. 6—Basic units of automatic simplex assembly with code-bell calling.

rapidly that after every slight pause, or even between words, a party speaking can be interrupted.

A typical assembly for automatic-simplex communication is shown in the block diagram of Fig. 6. In addition to the units used in the two-frequency duplex assembly, automatic-simplex operation requires an electronic-transfer unit and a receiving audio-amplifier unit. The latter provides a convenient place to block receiver audio output without disabling the radio-frequency portion.

The transmitting audio amplifier in the stand-by condition is unblocked and ready to amplify voice signals from the telephone line. Reception of a carrier signal blocks the amplifier, so that once reception has started, no transmission can occur until the equipment returns to the stand-by condition. On the other hand, if an outgoing voice signal reaches the amplifier from the telephone line with the stand-by condition in effect, it causes the entire receiver to be blocked so that no signal can be received until conditions return to stand-by. The switch from transmit to receive and vice versa requires that the equipment pass through the stand-by condition in each direction.

The electronic-transfer unit is the key unit in the automatic-simplex assembly. It switches the equipment automatically from stand-by to transmit or receive as required. A typical automatic simplex assembly is shown in Fig. 7.

7. Calling Systems

A number of different systems of establishing a call over a carrier channel are in general use. The most important are the following: code-bell calling, voice calling, automatic bell calling, and dial selective calling.

Code-bell calling is the system of calling often used on rural party lines in which all telephones on a given circuit

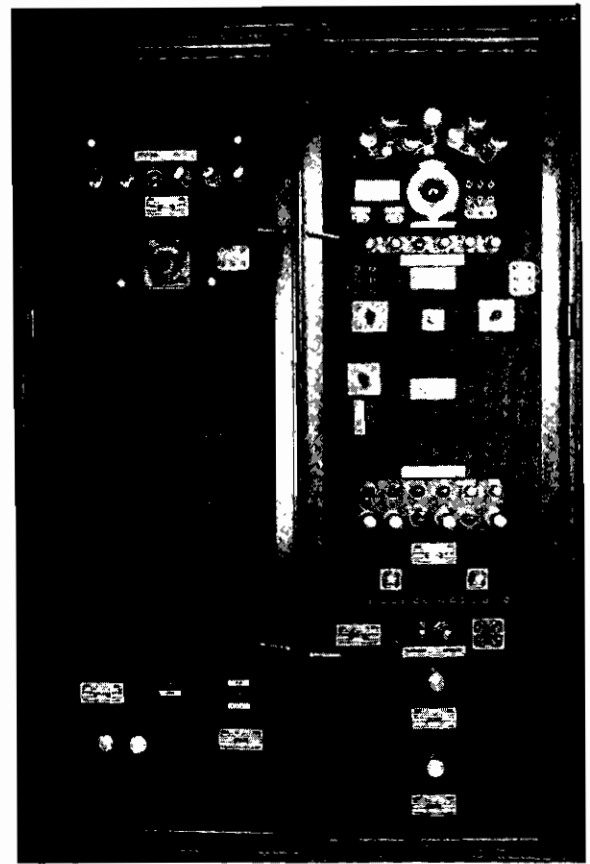

Fig. 7—Typical automatic simplex communication assembly. Units top to bottom, at left, superheterodyne receiver, switch and fuse panel, and high-voltage power supply. At right, transmitter, audio amplifier, hybrid and signalling unit, electronic transfer unit, bias-controlled audio amplifier, and two low-voltage power supplies.

ring, the desired party being indicated by a code made up of long and short rings. The calling party transmits the code by turning a hand generator or by applying a voltage to the line with a push-button on his telephone instrument. All telephones on the system ring in accordance with the transmitted code.

In the *voice calling* system, the call is placed by simply speaking the desired party's name into the telephone transmitter. Loudspeakers with individual amplifiers are provided at all telephone extensions to call the desired party. The loudspeaker is disconnected when the telephone instrument is picked up. Calling by voice is supplemented in some installations, especially those where ambient noise level is high, by a high-frequency audio tone, which is applied to the loudspeaker for a few seconds at the time the calling party picks up his telephone instrument.

In the *automatic bell calling* system, the bells on the telephone instrument or instruments at the opposite terminal are rung automatically when the calling party picks up his handset. The ringing continues for a few seconds and then is cut off automatically. To repeat the ring the calling party must hang up the telephone instrument and remove it again, or close the hook switch manually and then release it. Because this system provides no means of indicating which telephone on an extension should be

answered, it is used only on point-to-point carrier systems where only one extension is used at each end of the channel. A carrier channel linking two PBX boards provides an ideal application for the automatic bell calling system.

In *dial selective calling*, the desired number is dialed in the conventional dial-telephone manner. Each carrier set includes its own line-selector unit, which receives incoming dial pulses and applies ringing voltage to the wanted extension. Each of these selector units is in itself a complete private automatic-telephone exchange. The automatic-simplex carrier system with selective calling provides nearly every operating feature found on modern dial-telephone systems, such as a busy signal, a revertive or ring-back signal, local intercommunication, executive right-of-way or preferential service, and a disconnect signal.

8. Power Supply for Communication Assemblies

Alternating current at 120 or 240 volts generally has been used to supply carrier-communication equipment. At locations remote from generating sources, automatically starting motor-generator sets or converters have been used to provide power for the carrier set during emergencies or upon loss of normal a-c supply. This practice still is followed on long-haul channels using relatively high-powered equipment. Modern developments, however, have provided equipment capable of operating directly from 125- or 250-volt station batteries, making it possible to provide uninterrupted communication more economically, and without the maintenance problems associated with rotating equipment and accompanying control devices.

9. Carrier Relaying

Carrier-relaying systems and their application have been discussed in Chap. 11. A typical system is shown in Fig. 20 of that chapter. The application of the carrier equipment, as opposed to the application of the relays themselves, is basically the same as that for other carrier applications. The problems are greatly simplified, however, by the fact that relaying channels are always limited to the extent of a single line section and include line traps at each terminal. The relaying system normally requires use of the channel only during an actual fault, and the equipment is free for other applications for the remainder of the time. The system is always arranged so that the relays can interrupt any auxiliary functions in progress when a fault occurs.

A form of voice communication often termed "emergency communication" is usually inherently available in carrier equipment provided for relaying. Such communication is limited to the line section being protected, and since it is a "push-to-talk" system it is not suited to use with lengthy extensions or PBX boards. A rudimentary calling system, using the carrier itself as a calling signal, is usually employed. Because of these and other limitations, the communication function provided by carrier-relaying assemblies should not be considered in the same category with that provided by assemblies designed specifically for communication purposes.

10. Carrier Telemetry³

Telemetry is the indicating or recording of a quantity at a location remote from that at which the quantity

exists. The quantities most often telemetered on power systems are electrical quantities, usually kilowatts and kilovars; but hot-spot temperature, water level, tap-changer position, and many other quantities can be telemetered.

Some telemetering systems are intended for operation over metallic conductors only. Among these are the torque-balance and the slide-wire systems. Others are adaptable for use either over metallic conductors or carrier channels. These latter systems are generally based upon the principle of converting the indication to be telemetered into pulses of a definite character, a variation in the telemetered quantity being reflected as a variation in some characteristic of the transmitted pulse.

In the impulse-rate system, the frequency or rate of the pulses varies in proportion to the magnitude of the telemetered quantity. A reference or base rate of impulsing represents a magnitude of zero; impulse rates above the base rate represent positive increments in the quantity, and impulse rates below the base rate represent negative increments.

In the impulse-duration system, the frequency of the pulses is constant. The duration of the pulse during a complete pulsing cycle is proportional to the magnitude of the telemetered quantity.

The pulse telemetering systems are well suited to operation over carrier channels. The fact that the intelligence transmitted takes the form of simple pulses makes it possible to use in many applications a simple carrier assembly in which an unmodulated carrier is turned on and off by a pair of contacts controlled by the telemetering device. No special modulation schemes are necessary with these systems, and the accuracy of the received information is independent of variations in the attenuation of the channel over which it is transmitted.

11. Impulse-Duration vs. Impulse-Rate Systems

Impulse-duration systems are adaptable to telemetering a much wider variety of quantities than is the impulse-rate system, which is generally suitable only for the telemetering of electrical quantities, primarily kilowatts and kilovars. The Bristol Metameter system, for example, can be supplied with measuring elements for the telemetering of pressure, liquid level, and a number of other mechanical or hydraulic readings. The impulse-duration receiving instruments have the additional advantage that they can be easily adapted to retransmission of individual or totaled quantities.

The impulse-rate system, however, has a number of advantages in those applications to which it is suited. A complete impulse-rate system, including a suitable recording instrument, generally costs less than a corresponding impulse-duration system. The accuracy of the impulse-rate system is not affected by reasonable variations in the duration of the "on" and "off" periods of the impulse, an important consideration in applications where the telemetering signal must be received and re-transmitted at several points along its channel. Careful attention must be paid to the operating times of mechanical relays, and to the time-lag in audio-relay circuits, when impulse-duration signals are passed along in this fashion. Also, large

variations in signal level due to changes in attenuation affect the accuracy of impulse-duration systems operating on audio tones to an extent depending upon the flatness of the receiver *ave* (automatic-volume-control) characteristic.

12. Power-Line Carrier Telemetry Assemblies

The channel requirements for impulse telemetry systems are relatively simple; and because transmission alone or reception alone is usually required, the assemblies used for telemetry purposes are often correspondingly simple. If a single set of impulses is to be transmitted from a given point, the assembly often consists of a single frequency-shift carrier transmitter with a self-contained, a-c power supply. The carrier-frequency output of the transmitter is controlled directly by the impulse-forming device, which shifts the output back and forth between the mark and space frequencies as its contacts close and open.

At the receiving end of such a channel, a frequency-shift receiver is used to receive the carrier signal. The receiver operates a relay which in turn keys the impulse receiver.

In applications where more than two or three quantities are to be telemetered from a single point simultaneously, it is common practice to use audio-tone transmitter units to modulate the carrier-frequency signal. One tone frequency is used for each telemetered quantity, and the carrier wave is left on continuously. The telemetry as-

generator or a group of generators on a system in such a way as to maintain the system frequency and to regulate the interchange of power with other systems in accordance with a predetermined plan.

The frequency of a system or a group of interconnected systems is constant if the governor settings on all the prime movers cause the generators to produce exactly the amount of power required to supply the total load. If some of the load is suddenly lost, that part of the prime mover output initially supplying the dropped load is absorbed in accelerating all the units on the system, and a rise in system frequency occurs. Under these conditions, the output of one or more of the prime movers on the system must be reduced to restore the frequency to normal, and then increased slightly to maintain normal frequency.

In the operation of large interconnected systems or power pools, it is the practice for one large generating station to regulate its output on the basis of system frequency, reducing the governor settings of one or more prime movers if the system frequency is high and increasing the settings if the frequency is low, without regard to tie-line loads or total interchange of power with other systems. This type of operation is called flat frequency control. The other systems in the interconnected group regulate prime-mover outputs on the basis of the interchange of power among systems. For these other systems, there are several possible types of operation, most of which are based on regulating to produce a pre-determined net tie-line loading when frequency is normal, but allowing the tie-line loading to depart from the pre-determined value when the frequency is off normal.

The basic quantity used to govern the operation of automatic load controllers is the net power interchange of the system, which is combined with system frequency in most types of control. In the usual arrangement, net interchange is obtained by totalizing individual interchange readings at the dispatching office and combining the result with frequency in an automatic load controller located at that point. The controller generates "raise" and "lower" impulses that must be transmitted to the regulating station. Power-line carrier is often used as a medium for transmitting these signals.

14. Carrier Assemblies for Load-Frequency Control

The channel requirements for load-frequency control are similar to those for telemetry two quantities, since two types of impulses must be transmitted. A common arrangement is the use of a single carrier transmitter modulated by two audio-frequency tones, one for "raise" impulses and one for "lower" impulses. At the receiving end of such a channel, a single carrier receiver operates into a corresponding pair of tone receivers. An alternate system is the use of two frequency-shift channels, one for "raise" and one for "lower" impulses.

It is frequently desirable to arrange the system so that any one of several generating stations can be called on to act as the regulating station for the system. In this case the usual arrangement is for each such station to be equipped with an identical carrier-receiving assembly, tuned to the frequency of the load-control transmitter at the dispatching office. Any one of the stations can then

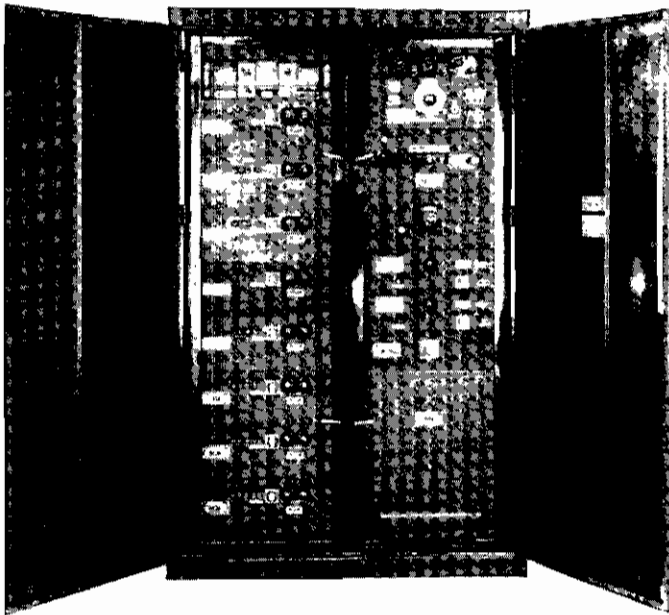

Fig. 8—Typical tone telemetry assembly with carrier receiver and eight tone receivers, and carrier transmitter with two tone transmitters. This assembly is capable of receiving eight simultaneous telemetered indications on one carrier frequency and transmitting two simultaneous indications on another.

sembly of Fig. 8 is used to receive eight separate telemetering tones on a single carrier frequency and transmit two other tones on another.

13. Load-Frequency Control

Load-frequency control is the control of the output of a

be placed on automatic control by the station operator, in accordance with the orders of the dispatcher.

15. Carrier Supervisory Control⁷

Supervisory control is a system of controlling and supervising from a central point to operation of equipment at one or more remote locations. Control and supervision of several separate pieces of equipment are accomplished with relatively few conductors or channels. In the Visicode supervisory-control system, which is the system considered in the subsequent discussion, only a single pair of wires or

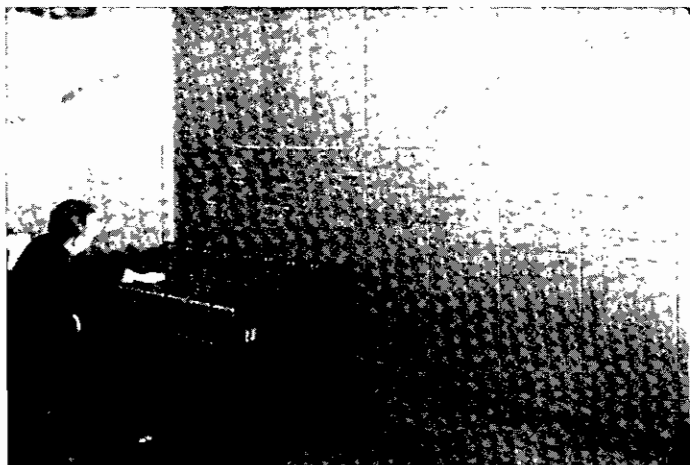

Fig. 9—Typical Visicode supervisory control desk.

a single carrier channel is required. A typical Visicode control desk is shown in Fig. 9.

In the Visicode supervisory-control system, supervision and control of many individual units of equipment are obtained by selective relay systems. These automatically generate and receive impulses in coded groups to perform the functions of selecting the apparatus to be controlled, performing the desired operation, and indicating that an operation has taken place. The latter function is performed whether the operation is initiated through the supervisory system or not.

16. Channel Requirements of Supervisory-Control Systems

The rate of impulsing of supervisory equipment is from 9 to 14 impulses per second, comparable to the speed of impulsing of a telephone dial. This rate of impulsing is considerably higher than the highest rate of any standard impulse telemetering system. The fastest such system in use has a maximum impulse rate of approximately 3.5 per second. In an impulse-rate telemetering system, it is necessary only that the channel preserve the rate of impulsing. The relative duration of the "on" and "off" periods is not important.

In the supervisory-control system the duration of the "on" period is approximately twice that of the "off" period. This relation must be preserved in order to allow proper sequential relay operations, some of which occur during the "on" period and some of which occur during the "off" period of the impulse cycle.

The high impulsing speed of the supervisory system and the requirement that the relative duration of the "on" and "off" periods be preserved make it undesirable to use more than one relaying point to retransmit mechanically supervisory impulses received from a distant point.

There are two types of Visicode supervisory control, one in which all the equipment to be controlled is located at a single point, and one in which the equipment is in several groups at different locations. These two types are referred to as the single-station and multistation systems, respectively.

A fundamental requirement of the multistation system is that a control or supervision function in progress between the dispatching office and a controlled station not be interfered with by supervisory signals from other controlled stations. This requirement is met by assigning different group codes to each station and arranging each station so that reception of a group code not associated with it locks out the supervisory equipment at that station. Each station must be able to receive all signals transmitted from any other station. In this way synchronism of impulses and successful lockout are assured, because the impulsing of any station is governed by impulses sent simultaneously from other stations.

When supervisory control is operated over a carrier channel provided for its exclusive use, impulsing of an otherwise unmodulated carrier signal normally is used. For this type of operation the transmitters and receivers at all locations operate on the same frequency, and all stations receive each other. Modifications of this arrangement are made in some cases to combine the supervisory system with other functions. In these cases supervisory control is usually operated over an audio-tone channel, a single tone receiver and transmitter being provided for supervisory in the carrier assembly at each location involved.

17. Combined Functions on a Carrier Channel^{3,4,7}

Many of the functions of power-line carrier that have been described can be performed simultaneously over a single carrier channel, and usually several carrier channels on the same line can make joint use of coupling and tuning equipment. Such efficient use of carrier equipment often justifies an investment in the apparatus that might not be justifiable for a single function alone.

Many functions that require the transmission of intelligence in the form of impulses, such as telemetering and load control, can be performed simultaneously over a single carrier frequency by modulating the carrier with audio-frequency tones. Each tone frequency is in effect a separate carrier channel itself, using the radio-frequency carrier channel as its "conductor". At the receiving end of such a channel, separate tone receivers are operated from the output of the radio-frequency receiver, each individual tone receiver being tuned to receive one particular audio tone and reject the others.

If continuous telemetering and simultaneous emergency communication are desired on a relaying channel, audio tones below 500 cycles can be used for several simultaneous telemetering functions, the audio frequencies above 500 cycles being used for speech. A filter is used to eliminate the tone frequencies from the speech at the sending and

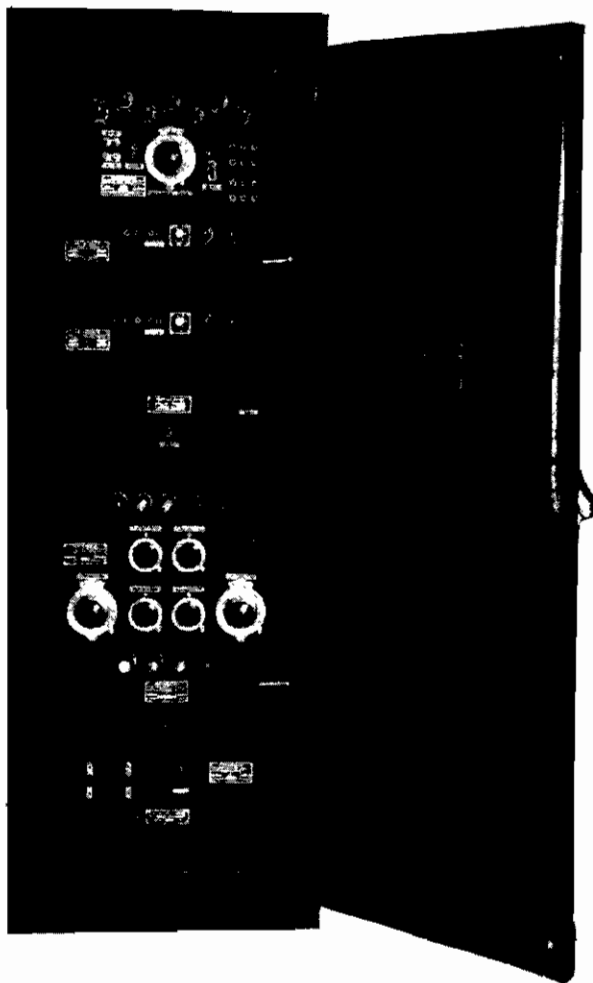

Fig. 10—A carrier assembly for simultaneous voice communication (emergency type), reception of two telemetered indications, and phase-comparison relaying. Top to bottom, carrier transmitter, two tone receivers, modulator, double-carrier receiver, phase-comparison relay control unit, switch and fuse panel, and high-pass filter for removing telemetering tones from speech.

receiving ends. Speech intelligibility is not perceptibly affected by the elimination of the speech frequencies below 500 cycles, because practically all the intelligibility is furnished by the frequencies above this figure. The carrier assembly shown in Fig. 10 is intended for relaying, emergency communication, and simultaneous reception of two telemetering tones.

With supervisory-control equipment, any number of quantities can be telemetered one at a time. Each telemetering function is made a point on the supervisory system, and the dispatcher selects the quantity he desires to read. Communication can be made a point on the supervisory system of single-station supervisory systems, and such supervisory systems can operate over relaying carrier channels.

Single-station supervisory-control systems on point-to-point carrier channels can be used in almost any desired combination with relaying, telemetering, load control, or communication. Two-frequency carrier channels are required for the combination of supervisory control with

continuous functions, such as telemetering or load control.

In multistation supervisory-control systems, all stations must receive all signals. Continuous carrier functions cannot be combined with multistation supervisory control on single-frequency carrier channels, and certain combinations of multistation supervisory control with relaying and communication equipment are not practical. Among these is the combination of supervisory control with multistation automatic simplex communication, and any combination of supervisory control with relaying that involves the use of carrier transmitters outside a protected line section, operating on the same frequency as those within the line section.

18. Modulation Systems

Three different modulation systems are available for use in power-line carrier applications. These are the amplitude modulation, the frequency modulation, and the single-sideband systems^{9,10,11}. Of these, amplitude modulation is by far the most widely used. In amplitude modulation (a-m) the amplitude or intensity of the transmitted wave is varied in accordance with the waveform of the intelligence to be transmitted. A mathematical analysis of the frequency components of the resulting signal shows that they include the carrier wave itself, unchanged in magnitude, frequency, or phase, plus so-called sideband components, two for each frequency contained in the modulating wave. These sideband components appear at frequencies equal to the carrier frequency plus each modulating frequency (upper sideband components) and carrier frequency minus each modulating frequency (lower sideband components). It is the beating of these sideband components with the carrier in the detector of an a-m receiver that results in the reproduction of the original intelligence at the receiving point.

The bandwidth occupied by an a-m signal is twice the frequency of the highest-frequency modulating signal, and the tuned circuits of an a-m receiver must be sufficiently broad to accept this bandwidth without appreciable attenuation at the extreme frequencies.

Since sideband components occur in pairs, one group above the carrier frequency and one below, it is evident that each sideband group contains all of the intelligence of the original signal. This indicates the possibility of halving the bandwidth required for transmission by suppressing one complete set of sideband components before transmitting the signal. Furthermore, since the carrier wave itself carries no intelligence and requires a large portion of the transmitted power, it is evident that an appreciable saving in power can be made by partially or completely eliminating the carrier wave at the transmitter, emphasizing or regenerating it at a low power level in the receiver.

This is done in the single-sideband system, in which one set of sideband components is suppressed and the carrier is partially or completely suppressed at a low level in the transmitter. If the original peak power used in the transmitter (as an a-m transmitter) is concentrated in the intelligence-bearing components of a single sideband, and if the receiver used has only the necessary bandwidth (half the bandwidth required for a-m service), there is a gain in

signal-to-noise ratio of nine db in favor of single-sideband transmission. Thus, single-sideband transmission offers the equivalent of increasing the original carrier power eight times, and requires only half the bandwidth required by the a-m system.

The frequency-modulation (f-m) system is also used in power-line carrier work. In this system the amplitude or intensity of the transmitted signal is constant and the frequency varies above and below a reference frequency in accordance with the intelligence being transmitted.

The deviation ratio, defined as the ratio of the maximum departure of the frequency from the reference value to the maximum frequency contained in the modulating signal, is a measure of the gain in signal-to-noise ratio of an f-m system over an a-m system of the same power. The f-m system provides marked increases in signal-to-noise ratio as the deviation ratio is increased. However, the minimum bandwidth required by frequency modulation is the same as that for a-m transmission of the same intelligence, and if a deviation ratio large enough to give a worthwhile increase in signal-to-noise ratio is used, the a-m bandwidth must be exceeded.

The frequency-shift system is a special form of frequency modulation that is used for telegraphic functions such as telemetering. In this system two closely-spaced frequencies are used. A continuous carrier wave of constant amplitude is shifted back and forth between the two frequencies, one frequency denoting a "mark" and one a "space" in the transmission of the impulses. By using highly stable crystal oscillators for the transmitted frequencies, and correspondingly stable and highly selective circuits in the receivers, it is possible to place the mark and space frequencies within 0.06 per cent of each other in the carrier spectrum. Even with this spacing, the equivalent f-m deviation ratio with the slow-speed keying required by practical impulse-telemetering systems is extremely high, with the result that a properly-designed frequency-shift system can provide substantial gains in signal-to-noise ratio with a small transmitted bandwidth.

III. PROPAGATION OF CARRIER ON TRANSMISSION LINES

19. Propagation Between Two Phase Conductors

Practically all textbooks on transmission give the classical solution for steady-state voltage and current at any point along a two-wire line^{12,13}. This solution is approximately valid for carrier propagation between two phase conductors of a transposed three-phase power line, because transpositions tend to nullify the effect of the presence of the third conductor. The solution is based on the assumption that the line is composed of an infinite number of resistors and inductors in series, with an infinite number of capacitors and resistors shunting the line at equally-spaced points. This solution can be written as follows:

$$E_s = \left(\frac{E_r + I_r Z_0}{2} \right) e^{(\alpha + j\beta)l} + \left(\frac{E_r - I_r Z_0}{2} \right) e^{-(\alpha + j\beta)l} \quad (1a)$$

$$I_s = \left(\frac{I_r + \frac{E_r}{Z_0}}{2} \right) e^{(\alpha + j\beta)l} + \left(\frac{I_r - \frac{E_r}{Z_0}}{2} \right) e^{-(\alpha + j\beta)l}, \quad (1b)$$

in which E_s and I_s are the sending end voltage and current, respectively.

E_r and I_r are the receiving end voltage and current, respectively.

Z_0 is the characteristic impedance as defined in the next paragraph.

$\alpha + j\beta$ is the propagation constant, to be defined later.

l is the distance from the receiving end, in the units of length used to define $\alpha + j\beta$.

20. Characteristic Impedance

Equations (1a) and (1b) show that when a voltage is applied to the sending end of the line, the voltage at any point on the line actually consists of two voltages, one a voltage traveling from the sending end of the line toward the receiving end, the other traveling from the receiving end back to the sending end. The former will be designated as E^+ , the latter as E^- . Each of these voltages is accompanied by a corresponding current, I^+ and I^- , respectively. The ratio of either voltage to its corresponding current at any point in the line is a constant Z_0 which is independent of the line length but is a function of the series resistance, the series inductance, the shunt conductance, and the shunt capacitance of the line per unit of length. This constant is the characteristic impedance of the line and can be expressed as

$$\frac{E^+}{I^+} = -\frac{E^-}{I^-} = Z_0 = \sqrt{\frac{R + j\omega L}{G + j\omega C}} \quad (2)$$

where R = resistance in ohms per unit length.

L = inductance in henrys per unit length.

G = shunt conductance in mhos per unit length.

C = shunt capacitance in farads per unit length.

and $\omega = 2\pi f$ where f is the frequency in cycles per second.

In actual practice at high frequencies, such as those used in carrier transmission, the quantities $j\omega L$ and $j\omega C$ are so large by comparison with R and G that the latter can be neglected and the characteristic impedance expressed simply as

$$Z_0 = \sqrt{\frac{L}{C}} \quad (3)$$

or by applying conventional formulas for L and C as

$$Z_0 = 276 \log_{10} \frac{2D}{d} \quad (4)$$

where D is the distance between conductors and d is their diameter in the same units. Ordinary high-voltage transmission lines show characteristic impedances of 600 to 900 ohms between any pair of phase wires. Table 3 of Chap. 9 gives line-to-neutral surge impedances of a number of typical lines. The single-phase surge impedances are twice the values shown in this table.

21. Propagation Constant

Further study of the solution for a two-wire line shows that the phase and magnitudes of the voltage and current traveling toward the receiving end change as they progress along the line. The forward voltage and current at any point can be expressed as

$$E^+ = E_1^+ e^{(\alpha + j\beta)\Delta l} \quad (5a)$$

$$I^+ = I_1^+ e^{(\alpha + j\beta)\Delta l} \quad (5b)$$

where E_1^+ and I_1^+ are the values at some intermediate point on the line at a distance Δl toward the receiving end. Likewise, the voltage and current traveling in the opposite direction, E^- and I^- , change as they progress along the line, for

$$E^- = E_1^- e^{-(\alpha + j\beta)\Delta l} \quad (6a)$$

$$I^- = I_1^- e^{-(\alpha + j\beta)\Delta l} \quad (6b)$$

The quantity $\alpha + j\beta$ is the propagation constant of the line, which can be expressed as

$$\alpha + j\beta = \sqrt{ZY} = \sqrt{(R + j\omega L)(G + j\omega C)}. \quad (7)$$

The real part of $\alpha + j\beta$ is an exponent that expresses the reduction of the amplitudes of the forward and reverse voltages and currents as they appear at various points along their respective directions of travel. The imaginary part expresses the phase shift of the voltages and currents that results from the finite time required for the waves to travel from one point to another on the line.

22. Standing Waves

The forward and reverse voltages (and currents) aid and oppose each other at various points along the line, depending upon their respective phase positions. The total voltage and the total current therefore exhibit maxima and minima at equally spaced points separated by a distance that is a function of the frequency, giving rise to the phenomenon of standing waves. The magnitudes of the maxima and minima are a function of the amount of energy reflected from the receiving end of the line.

Standing waves increase the losses in a line as compared with the losses obtained without reflection or standing waves. They also result in increased radiation of energy from the line and other usually undesirable effects.

23. Attenuation

The attenuation of a proposed channel is of prime importance in carrier application, because it determines the fraction of the transmitted energy available at the receiving end to overcome noise and interfering voltages.

If, as in practical open-wire lines at carrier frequencies, the shunt conductance G is negligible and R is small compared to $j\omega L$, the real part of the propagation constant (Eq. 7) can be expressed as

$$\alpha = \frac{R}{2Z_0} \text{ nepers per unit of length} \quad (8a)$$

or

$$\alpha = \frac{4.34R}{Z_0} \text{ decibels per unit of length.} \quad (8b)$$

The resistance R is the resistance of the conductors per unit of length at the frequency in question. Calculation of R is difficult for the usual transmission line using stranded conductors, because common skin effect formulas apply accurately only to round conductors. Formulas for stranded conductors have been developed, and these give good results for unweathered surfaces and straight parallel strands, but are subject to errors depending on the condi-

tion of the conductor surface and the twisting of the strands in an actual line.

Most of the literature on power-line-carrier transmission reports measured values of attenuation in excess of figures calculated from theoretical considerations. The differences in these cases appear too great to be accounted for by expected errors in the determination of skin effect. For this reason, it is the usual practice in power-line-carrier application to use attenuation figures based on measurements on actual lines, rather than calculated figures. A table of approximate attenuation figures is given in a later section of this chapter.

24. Line Input Impedance

The reverse voltage and current expressed by the second terms of Eqs. (1a) and (1b) result from reflection of the forward voltage and current at the receiving end of the line. Equation (1) shows that if the line is terminated at the receiving end in an impedance equal to its characteristic impedance, Z_0 , so that $\frac{E_r}{I_r} = Z_0$, there is no reverse voltage or current; i.e., no reflection at the receiver terminal. Under these conditions the input impedance Z_i at the sending end of the line is the surge impedance Z_0 , and the ratio of total voltage to total current everywhere along the line is equal to Z_0 . Also, if the line is sufficiently long, the second terms of Eqs. (1a) and (1b) are at the sending end negligible in magnitude by comparison with the first terms, even though the line is not terminated in Z_0 . In this case also the input impedance is Z_0 . This latter condition is often approached in practical carrier applications on isolated untapped lines. Carrier transmitters and receivers do not ordinarily provide a termination equal to the surge impedance of a line, but most carrier channels are sufficiently long that the input impedance of an isolated line is for practical purposes the characteristic impedance.

A special case that must be considered is that of short tap or spur lines that bridge a line over which carrier energy is to be transmitted. The input impedance of such a line may be extremely low under certain conditions and may constitute practically a short circuit across the carrier channel.

Consider, for example, the case of a low-loss line, open-circuited at the receiving end, one quarter wavelength long at a certain frequency. Voltage of this frequency applied to the input terminals, upon arriving at the receiving end, is reflected toward the source unchanged in magnitude and polarity, and has travelled a total of one-half wavelength by the time it reaches the source. It is exactly 180 degrees out of phase with the voltage being impressed at that instant and practically neutralizes it. It is impossible, therefore, to establish an appreciable voltage across the input terminals of a low-loss quarter wavelength line, because the reflected voltage always opposes any voltage that may be impressed. Such a line therefore appears as practically a short circuit at the particular frequency at which it is a quarter wavelength long.

The same phase relations apply for a line that is any odd multiple of a quarter wavelength long. The greater the number of quarter wavelengths, however, the greater the total attenuation of the voltage along the path from the

source to the open end and back again, so that less and less of the input voltage is neutralized and the line appears to have progressively greater input impedance at the minimum points as its length is increased.

On the other hand, if an open-circuited low-loss line is half wave-length long, current arriving at the receiving end is reflected with reversed polarity. Upon returning to the sending end a full cycle after having entered the line, this reversed current directly opposes the current entering the line and practically neutralizes it at all instants of time. Thus, it is impossible to establish an appreciable current at the input terminals of such a line regardless of the voltage applied. In other words, the input impedance of a half wave-length open-ended line is extremely high. The input impedance of a line that is a multiple of a half wave in length depends upon the attenuation of the current wave along the path from sending end to receiving end and back again. The longer the line the lower is this impedance.

In the case of an open-ended line of a given length, as the frequency is varied over the normal carrier band from 50 to 150 kc, the input impedance of the line oscillates between maxima and minima at frequencies for which the line is half wave and odd-quarter-wave resonant, respectively. At a given frequency, as the length of a practical line is increased, similar maxima and minima occur, but each succeeding maximum and minimum point is closer to the surge impedance of the line. This is illustrated in Fig. 11,

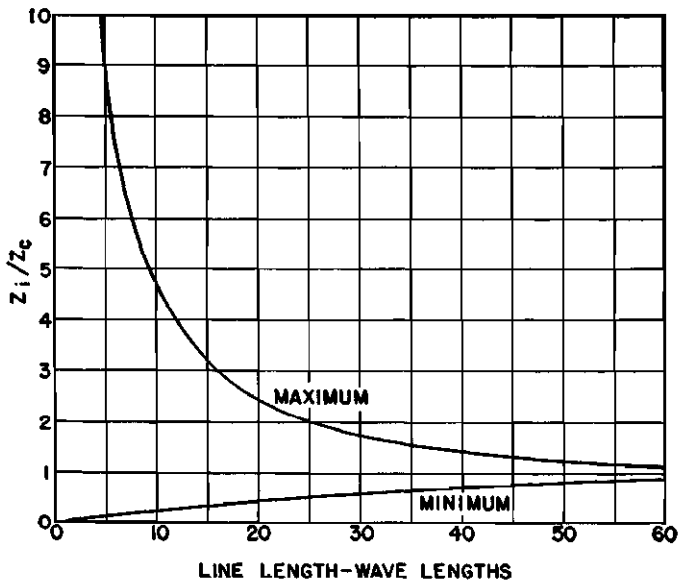

Fig. 11—Envelope of the minimum and maximum input impedance Z_i at 100 kc of a line with attenuation of 0.186 db per wavelength (0.1 db per mile).

which shows the envelope of the input impedance of an open-ended line, having an attenuation of 0.1 db per mile at 100 kc, as the length is increased.

In power systems a line actually terminated in an open circuit at carrier frequencies is rarely encountered. A much more common case is that of short spur or tap lines terminated in power transformers, which at carrier frequencies usually appear as a shunt capacitance of several hundred to several thousand ohms. The effect of a capacitance

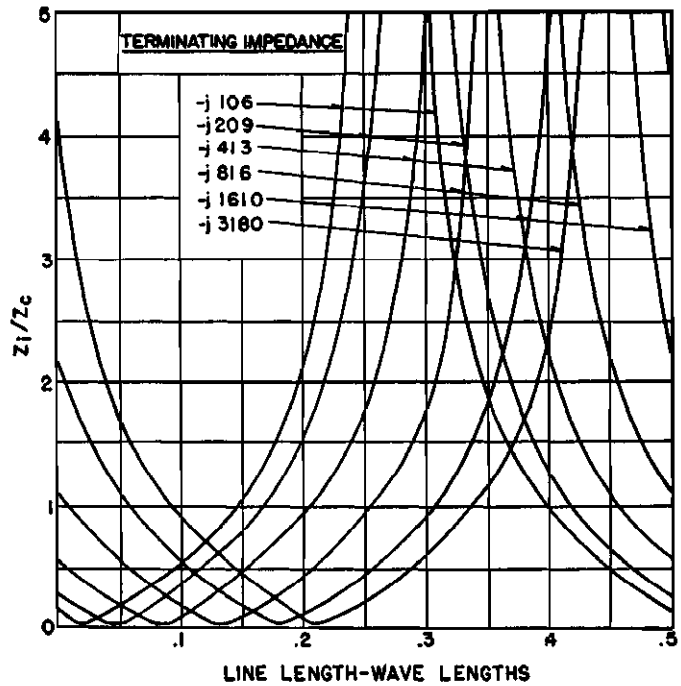

Fig. 12—Input impedance Z_i of a typical line with various capacitive reactance terminations.

termination is to make the line equivalent to a somewhat longer line terminated in an open circuit. For example, Fig. 12 shows the input impedance of a line of 730 ohms characteristic impedance as a function of length for various capacitive reactance terminations.

25. Propagation on Ground-Return Circuits

The equations for the propagation of energy over a circuit consisting of a single isolated conductor with ground return correspond exactly in form with Eqs. (1a) and (1b) for a two-wire circuit. In ground-return carrier transmission on power lines, however, the phenomena are complicated by the presence of the other conductors and the ground wires, because induced currents flow in these paths as a result of their coupling with the conductor to which the energy is initially applied. The equations for this case are much more complicated.

Chevallier has given a symmetrical-component treatment of ground-return carrier transmission on three-phase lines¹⁴. He resolves the applied line-to-ground voltage into positive-, negative-, and zero-sequence components and uses corresponding propagation constants and characteristic impedances with each. His results show that the presumably unused phase conductors actually play an important role as return conductors in line-to-ground transmission. In practical cases, at a distance of 50 miles or so from the terminals on long lines without ground wires, the amount of carrier current that flows in the ground is negligible in comparison with that returning to the source via the two opposite conductors in parallel.

The general equations derived by Chevallier include both the forward and reverse components of voltage and current for voltage applied in any manner to the line; i.e., phase-to-phase, phase-to-ground, or otherwise. Of greatest in-

terest is the case of line-to-ground coupling on long or properly terminated lines, in which reverse voltage and currents can be neglected. The equations are simplified in this case, and with carrier voltage E_s applied between phase one and ground, as shown in Fig. 13, the voltages to

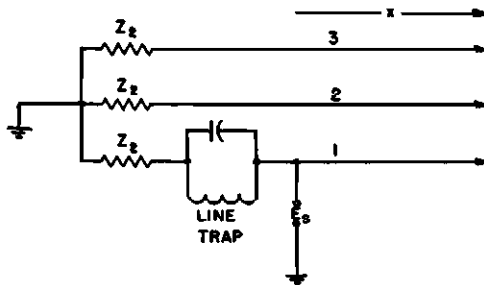

Fig. 13—Configuration assumed in discussion of propagation on ground return circuits. The impedances Z_2 may be lumped impedances or may be a continuation of the transmission line.

ground on phases 1, 2, and 3 at a distance x from the transmitting point are:

$$E_1 = \frac{E_s}{1+2Z'} e^{-k_0 x} + \frac{2Z'}{1+2Z'} E_s e^{-kx} \quad (9a)$$

$$E_2 = \frac{E_s}{1+2Z'} e^{-k_0 x} - \frac{Z'}{1+2Z'} E_s e^{-kx} \quad (9b)$$

$$E_3 = E_2 \quad (9c)$$

and the corresponding currents are:

$$I_1 = \frac{1}{Z_0} \frac{E_s}{1+2Z'} e^{-k_0 x} + \frac{2Z'}{Z(1+2Z')} E_s e^{-kx} \quad (10a)$$

$$I_2 = \frac{1}{Z_0} \frac{E_s}{1+2Z'} e^{-k_0 x} - \frac{1}{Z} \frac{Z'}{1+2Z'} E_s e^{-kx} \quad (10b)$$

$$I_3 = I_2 \quad (10c)$$

In which

k_0 = zero-sequence propagation constant (propagation constant for voltage applied to all three phases in parallel, with ground return).

Z_0 = zero-sequence characteristic impedance (characteristic impedance of all three phases in parallel, with ground return).

k = Positive- or negative-sequence propagation constant (propagation constant for a three-phase carrier frequency wave; i.e., square root of the product of line-to-neutral impedance and line-to-neutral admittance.)

Z = Positive- or negative-sequence characteristic impedance, line to neutral.

$$Z' = \frac{Z}{Z_0} \frac{Z_0 + Z_2}{Z + Z_2}$$

Z_2 = Load impedance (to neutral) on phases 2 and 3 at coupling point. See Fig. 13.

The first term in each of these equations is a zero-sequence term. The attenuation of the zero-sequence terms is high on lines without ground wires, because of the high resistivity of the ground return path. These terms become negligible on long lines in comparison with the positive-

and negative-sequence terms at a certain distance from the coupling point, and propagation takes place almost entirely between the coupled phase and the other two. The return current divides equally between the latter.

It has been noted that the attenuation per unit of distance is greater on short line-to-ground channels than on long line-to-ground channels⁹. Equations (9) and (10) provide at least a partial explanation of these results.

At the receiving point the current in the two uncoupled phases causes a loss of energy in the terminating impedances of these phases beyond the receiving point. This loss and the corresponding loss in the terminating impedances on the opposite side of the transmitting point account for the extra attenuation noticed in long line-to-ground channels as compared with phase-to-phase channels, according to Chevallier's results.

26. Characteristic Impedance of Ground-Return Circuits

The characteristic impedance of a circuit consisting of a single conductor with ground return is

$$Z_0 = 138 \log_{10} \frac{2h}{r} \quad (11)$$

where h is the height of the conductor above ground and r is its radius in the same units. Typical values for phase-to-ground carrier channels range from 400 to 600 ohms. The characteristic impedance of a transmission-line conductor with ground return is not greatly affected by the presence of the other conductors.

IV. NOISE VOLTAGE ON TRANSMISSION LINES

Since signal-to-noise ratio is the main criterion of the performance of a carrier transmission system, the noise level present at the receiving end of a carrier channel is equally as important to successful operation as the attenuation of the transmission path. The most important noise in a carrier system is that which originates in the power system itself; atmospheric noise is negligible, except that caused by nearby lightning strokes. The normal noise in a transmission system is the result of the presence of innumerable small arcs in dirty or defective insulators, poor joints, and the like. This condition is aggravated by wet weather, and is sometimes accompanied by corona discharge during such periods, with the result that noise usually increases to several times its normal amount. Noise also varies with the time of day under good weather conditions. Superimposed upon this normal or steady noise is the noise caused by switch operations, faults, etc.

27. Types of Noise^{13,21,22}

Noise from whatever cause can be classified under two general headings: random noise and impulse noise. Random noise has a continuous frequency spectrum, containing all frequencies in equal amounts. At the output of a receiver it produces a steady hissing or rushing sound. The rms amplitude of this type of noise at the output of a receiver is proportional to the square root of the bandwidth of the receiver; i.e., the noise power is proportional to the band-

width. The average and peak amplitudes are also proportional to the square root of the bandwidth.

Impulse noise is of far greater importance in carrier systems. It is produced when discrete, well-separated pulses exist at the input terminals of a receiver. If the pulses are irregular, the frequency spectrum is continuous and depends only slightly upon frequency. If the impulses are uniform and regularly spaced, the spectrum contains discrete frequency components separated by a frequency corresponding to the repetition rate. Power-line noise is essentially a combination of these two types of impulses, since basic repetition rates of 60 and 120 cycles are discernible along with random discrete pulses, all of irregular amplitude.

28. Response of a Receiver to Impulse Noise¹⁸

When a sharp impulse is applied to the input terminals of a receiver, the signal at the detector input is a damped oscillation having the natural resonant frequency of the preceding tuned circuits. The envelope of this oscillation, which represents the output of the receiver after detection, rises to a peak value at a certain time and then decays to zero. The greater the number of tuned circuits and the greater their Q , the more slowly the envelope of the oscillation rises to a maximum and the lower its peak value; i.e., the peak output is proportional to receiver bandwidth. However, the total area of the output signal envelope, and hence the average output, are independent of these factors. In practice, if the impulses are sharp and well separated, the rms output is independent of the shape of the impulses and is dependent only upon their areas, the gain of the receiver, and the square root of the receiver bandwidth. If the impulses are not well separated, so that in a receiver of a given bandwidth the resulting wave trains overlap, the response of the receiver simulates that for a combination of random noise and impulse noise. In some applications the peak output is of major importance, whereas in others the average or the rms output is the critical factor.

Thus, in specifying the characteristics of noise on transmission lines, it is necessary to state not only the relative amounts of random and impulse noise in a given bandwidth, but also the peak values of the impulses (or their statistical distribution) and the duration and spacing of the individual impulses. In order to evaluate the effect of this noise upon a given receiving system, it is necessary to know the receiver bandwidth and gain and the particular application involved. The number of tuned circuits and their Q determine the receiver bandwidth at a given frequency.

29. Measurement of Carrier-Frequency Noise on Power Lines

The accurate measurement of all the characteristics of carrier-frequency noise on transmission lines requires a considerable amount of equipment, including a noise meter of definite bandwidth, capable of measuring peak impulse amplitudes, and an oscilloscope to indicate the spacing and the duration of the impulses. In order to be significant, readings should be taken over a period of time sufficient to include both fair and rainy weather. As a result, actual test data of this type on carrier-frequency noise is ex-

tremely limited, and no typical figures for "quiet" or "noisy" lines have been established.

Figure 14 shows the results of one set of measurements made during fair weather on a 132-kv line that can be classified only as "relatively noisy" for carrier. These measurements were made with a Stoddart Type URM-6

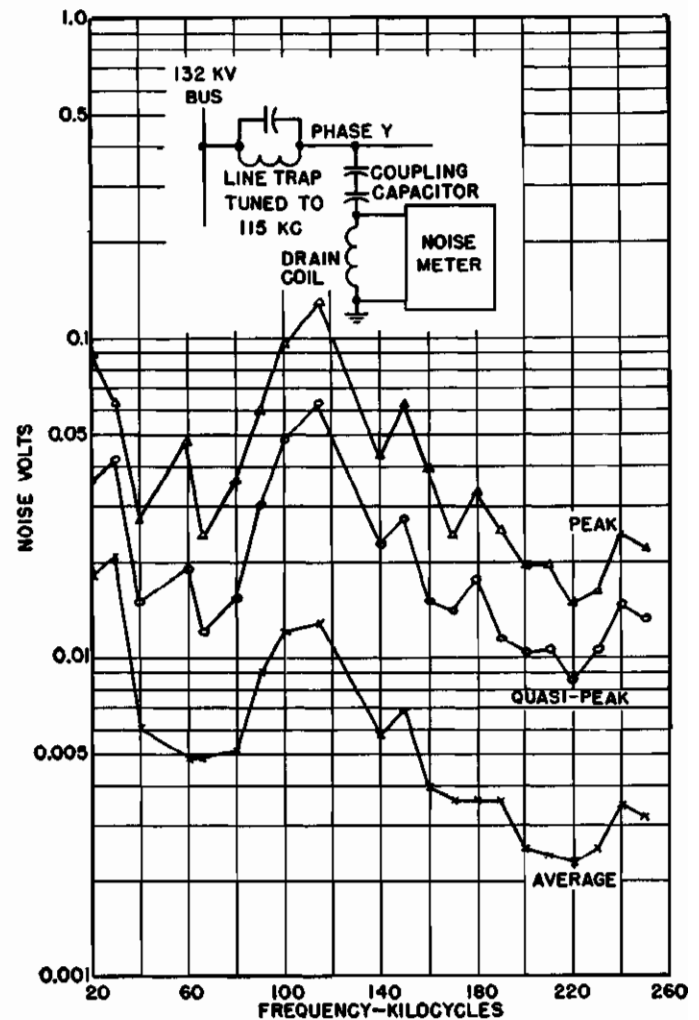

Fig. 14—Noise voltages as a function of frequency on a relatively noisy 132-kv line. The rise in the vicinity of 115 kc is probably accounted for by the presence of the line trap.

noise meter. The curves show that the peak values of noise on this line are far in excess of the average values, indicating that average-reading instruments do not give a true indication of the probable interfering effects of noise for all applications. A graphic record of quasi-peak values* over an extended time, including periods of rainy weather, gave the curves of Fig. 15, which indicate a relatively great increase in the noise under some conditions, with maximum quasi-peak values exceeding 100,000 microvolts for approximately 3 percent of the time.

*Quasi-peak readings are based on a fast detector output circuit charging time and a slow discharging time, and hence are a function of the peak amplitudes as well as the spacing of the impulses. The times are chosen so that the quasi-peak readings are approximately proportional to the interfering properties of impulse noise in aural reception of a-m signals.

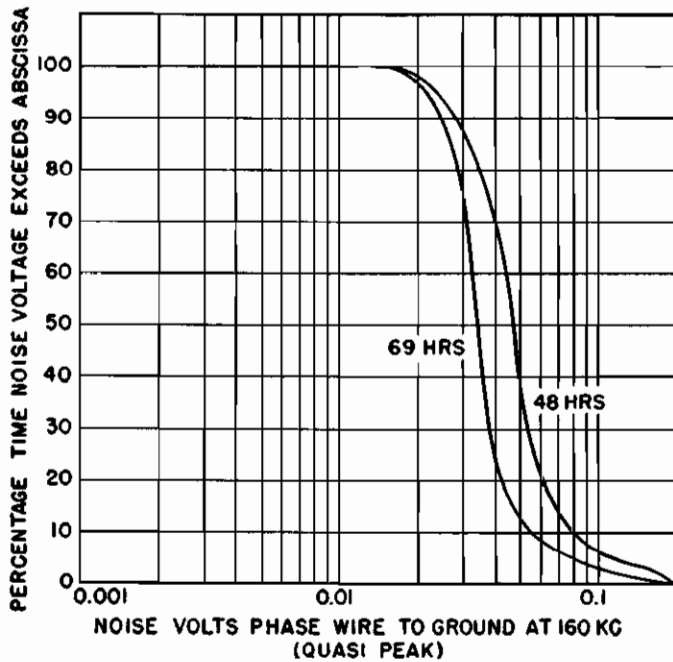

Fig. 15—Quasi-peak noise voltages at 160 kc taken over two extended periods on the same 132-kv line. Both periods included rainy as well as fair weather.

Cathode-ray oscilloscope patterns of the output of the detector of the noise meter used are shown in Fig. 16. These indicate irregularity in the pulses, even with 1/30-second exposures. The five-second exposure shows that although the basic system frequency is present in the amplitudes, the pulses occur almost at random throughout the cycle. It must be remembered that these pulses have undergone a smoothing and rounding effect as a result of the action of the tuned circuits in the noise meter and that the actual pulses at the input of the meter were sharper and of shorter duration than those shown in the photographs.

V. COUPLING AND TUNING EQUIPMENT AND CIRCUITS

In the early days of power-line carrier it was universal practice to couple the carrier equipment to the power line by a method known as antenna coupling. In this method the carrier equipment was connected to an isolated conductor, several spans long, on the same tower with the circuit to which coupling was to be effected. Eventually it was realized that the energy which found its way into the power line was transferred mainly through the capacitance between the antenna and the line, and this led to the development of compact capacitor units for coupling purposes. Such coupling capacitors are safer, easier to install, and are a more efficient coupling means than antennas. They also have the advantage that they can be used simultaneously in conjunction with potential devices to supply a voltage proportional to line voltage for the operation of protective relays and indicating instruments.

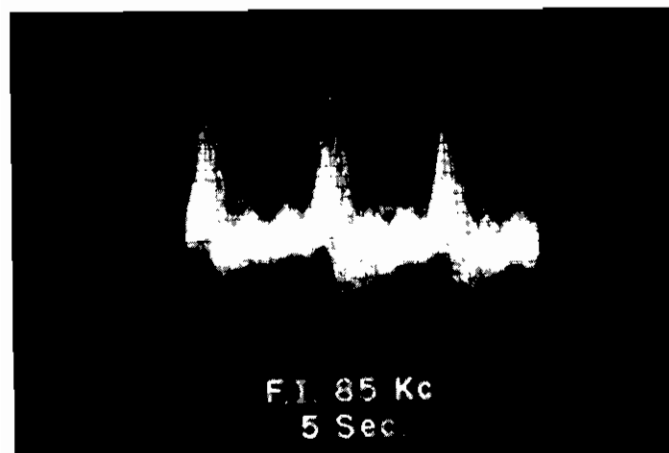
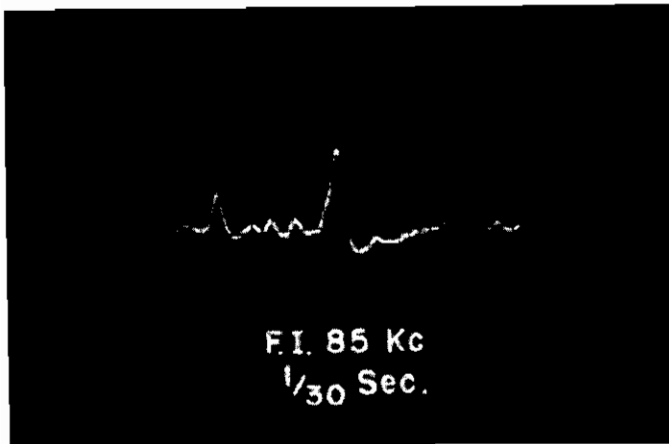

Fig. 16—Oscilloscope patterns of carrier noise at 85 kc with 1/30 second and 5 second exposures.

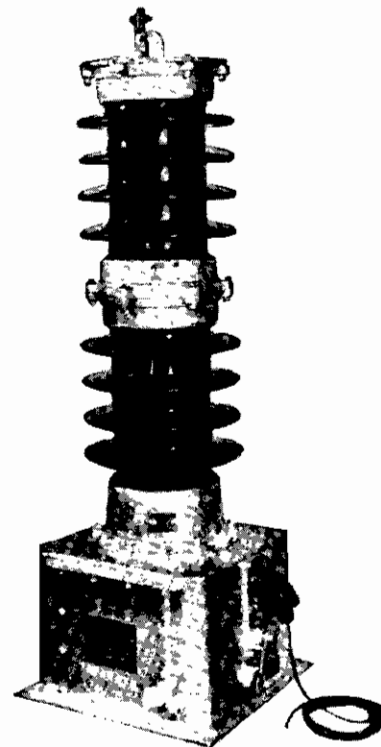

Fig. 17—Typical carrier coupling capacitor. This unit is rated at 115 kv and has a total capacitance of .00187 mfd.

30. Characteristics of Coupling Capacitors

A typical carrier coupling capacitor is shown in Fig. 17. The capacitor element proper is contained in a cylindrical porcelain housing with cast metal ends. The capacitor elements consist of a large number of individual working sections in series. Each working section is made up of an assembly of special paper and foil, non-inductively wound and impregnated.

Individual capacitor units are made up in several different voltage ratings, and one or more such individual capacitor units can be used in a stack to make up the complete coupling capacitance. The stack is mounted on a metal base that contains a grounding switch, a protective gap, and a carrier drain coil. These are connected as shown in Fig. 18. The purpose of the drain coil is to ground the

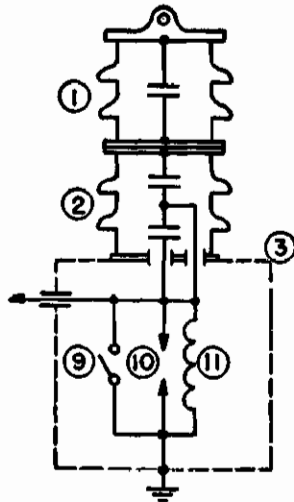

Fig. 18—Schematic of carrier coupling capacitor without potential device.

- (1) Coupling Capacitor
- (2) Multi-Unit Coupling Capacitor
- (3) Base Housing
- (9) Carrier Apparatus Grounding Switch
- (10) Carrier Apparatus Protective Gap
- (11) Carrier Drain Coil

capacitor terminal opposite the line terminal at 60 cycles and at the same time offer a high impedance at the carrier frequency. The grounding switch is used to by-pass the drain coil, providing a means of directly grounding the capacitor during inspection and maintenance of the coupling and tuning equipment. The gap protects the drain coil from excessive surge voltages during normal operation.

The capacitances of typical coupling capacitors of various standard voltage ratings are shown in Table 1, along with typical impulse and low-frequency test voltages. A typical power factor for coupling capacitors at carrier frequencies is 3 percent.

A diagram of a coupling capacitor with a potential device included in the base housing is given in Fig. 19. The potential device is essentially a transformer connected across a portion of the capacitance of the lower or base unit, deriving therefrom a voltage proportional to line voltage in accordance with the potential dividing proper-

TABLE 1—CHARACTERISTICS OF TYPICAL COUPLING CAPACITORS

System Voltage kv	Average Coupling Capacitance mfd.	Average Capacitance of Tap for In-Phase Potential Device mfd.	Low Frequency Test RMS kv		Impulse Test Crest kv, (+) or (-) $1.5 \times 40\mu S$ Full Wave
			One Minute Dry	Ten Seconds Wet	
46	.004	.0205	110	100	250
69	.00275	.0225	165	145	350
92	.002	.0205	215	190	450
115	.00187	.0225	265	230	550
138	.00137	.0225	320	275	650
161	.00125	.0225	370	315	750
230	.00094	.0225	525	445	1050
287	.00075	.0225	655	555	1300

Note: If in-phase potential device is used, total capacitance for carrier is tap capacitance in series with coupling capacitance. If in-phase potential device is not used, tap capacitance is short-circuited.

ties of the capacitor string. A variable-reactance transformer is provided for adjusting the phase angle of the derived voltage, and a voltage-adjusting transformer is provided for adjusting its magnitude. The potential device is connected to the capacitor through a carrier-frequency choke coil that isolates the device from the capacitor at carrier frequencies.

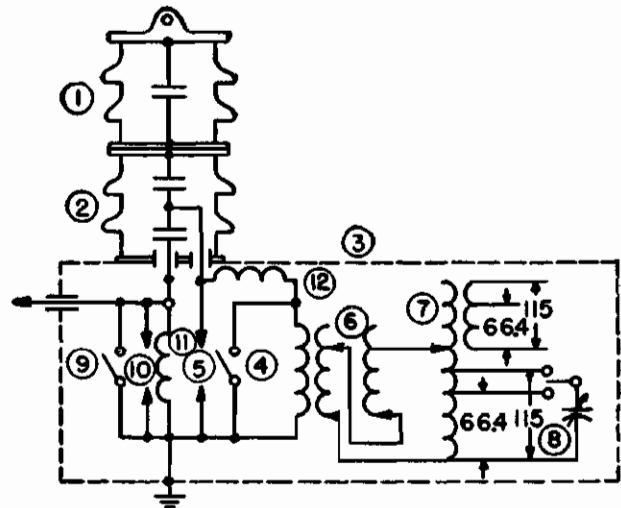

Fig. 19—Schematic of carrier coupling capacitor with potential device. A larger base than the one shown in Fig. 17 is used when the potential device is included.

- (1) Coupling Capacitor
- (2) Multi Unit Coupling Capacitor
- (3) Base Housing
- (4) Transformer Grounding Switch
- (5) Transformer Protective Gap
- (6) Variable Reactance Transformer
- (7) Voltage Adjusting Transformer
- (8) Power Factor Correction Capacitor
- (9) Carrier Apparatus Grounding Switch
- (10) Carrier Apparatus Protective Gap
- (11) Carrier Drain Coil
- (12) Carrier Choke Coil

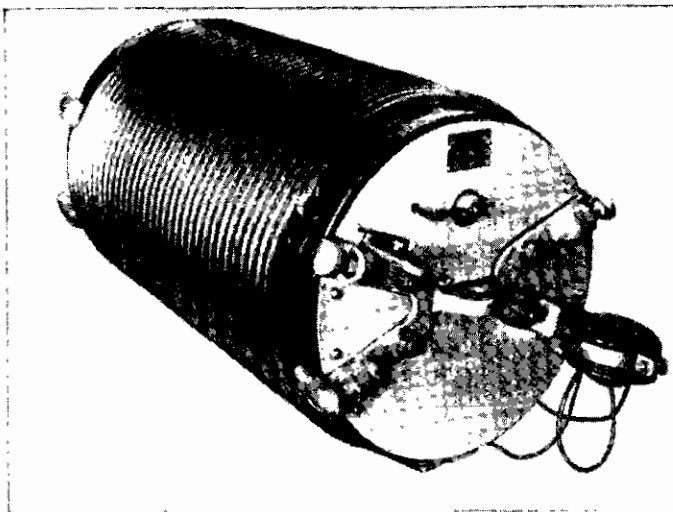

Fig. 20—Typical 400-ampere carrier line trap. (Type P-400).

31. Characteristics of Line Traps¹⁶

A line trap is a parallel resonant circuit tuned to offer a high impedance at a specific carrier frequency and inserted in series with one of the conductors of a transmission line. Line traps have negligible impedance at power frequencies and therefore do not affect normal power current.

A previous discussion in this chapter pointed out the deleterious effect that short spur or tap lines may have when bridged across a carrier channel. Such lines can be isolated from the carrier system by the insertion of line traps in series with one or more conductors of the spur line at its junction with the main line. Loops that offer alternate paths to the carrier current can be broken up by use of line traps. A line trap is always used at each end of a line section to which carrier relaying is applied. Their major purpose in this application is to prevent a nearby fault on an adjacent line section from short-circuiting the carrier channel and interrupting the transmission of a blocking signal to the opposite end of the line. In general, line traps provide a means of raising signal levels by confining the major portion of the carrier energy to its intended path and by isolating sources of high attenuation from the carrier circuit.

A typical carrier line trap is shown in Fig. 20. This unit is rated at 400 amperes at 60 cycles. The main coil is a heavy copper cable, capable of carrying the full power

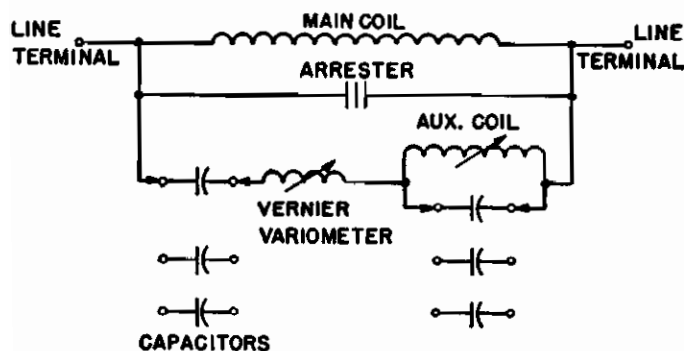

Fig. 21—Schematic of double-frequency line trap. (Type PDF-400).

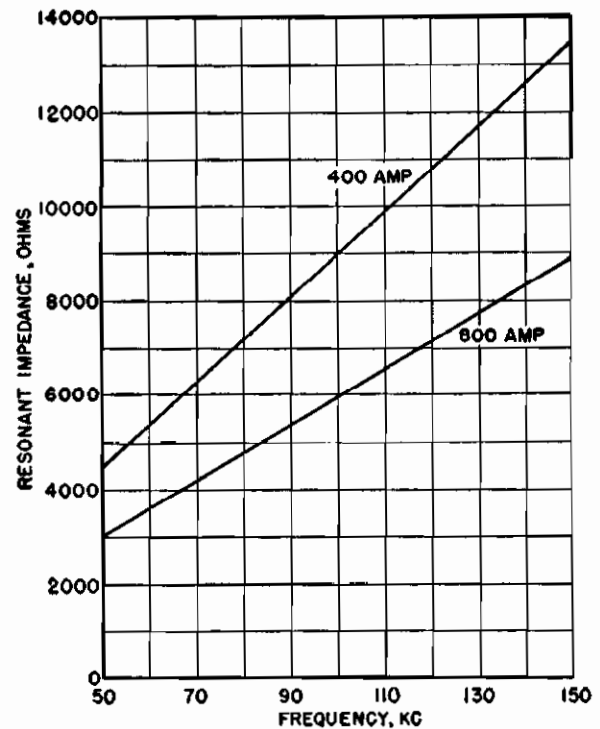

Fig. 22—Resonant impedance of typical 400- and 800-ampere line traps. The difference in impedance is due to the different inductances used in the two ratings.

current of the conductor into which it is inserted. This coil is wound on a porcelain cylinder, which also serves as a housing for the adjustable capacitor unit used to tune the coil to resonance at the desired frequency. A lightning arrester is provided across the trap to protect the capacitor unit from damage due to surges.

Manufacturers have standardized on 400 and 800 ampere ratings for line traps, and single- and double-frequency

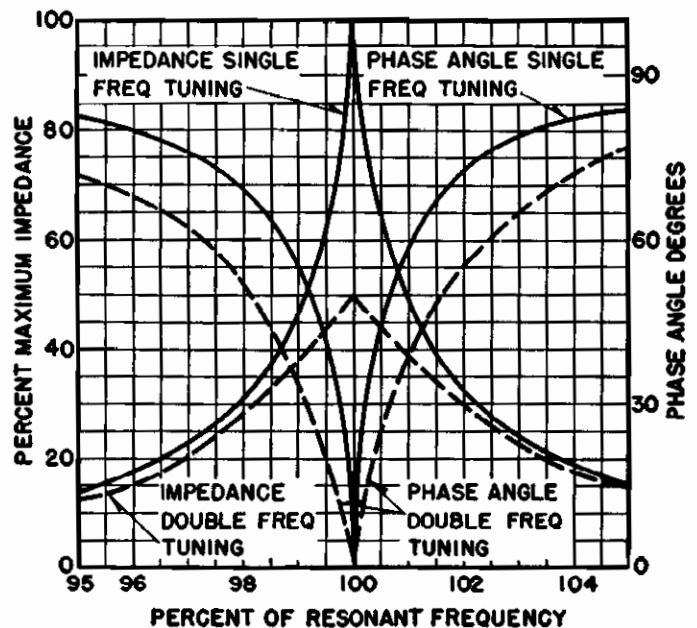

Fig. 23—Resonance curves of typical single- and double-frequency line traps.

models are available in both ratings. A schematic diagram for a double-frequency trap is shown in Fig. 21. The external appearance of a double-frequency trap is the same as that of a single-frequency trap of the same rating, because the extra circuits used to obtain the double-resonance characteristic are contained inside the main coil, which is the same in both cases.

The resonant impedances of typical 400- and 800-ampere line traps over the 50-150-kc band are given in Fig. 22. The difference in the two curves results from the difference in the inductances of the coils used in the two ratings. Figure 23 gives resonance curves for typical 400- and 800-ampere single- and double-frequency traps.

When a line trap is used to isolate a low-impedance circuit, the losses are not reduced to zero but to a value that is a function of the characteristic impedance of the carrier channel and the impedance of the trap in the vicinity of resonance. Figures 24 and 25 are curves of the losses in typical single- and double-frequency traps respectively when a line-to-ground channel of 500 ohms characteristic impedance is grounded through them. Losses in practical applications are somewhat less, depending upon the actual impedance of the offending circuit or device, and the losses shown by these curves should be taken as limiting values.

A single line trap at the end of a line-to-ground coupled channel does not materially reduce interference to channels on the same or nearby frequencies on lines beyond the trap, because it does not interrupt the current in the two un-

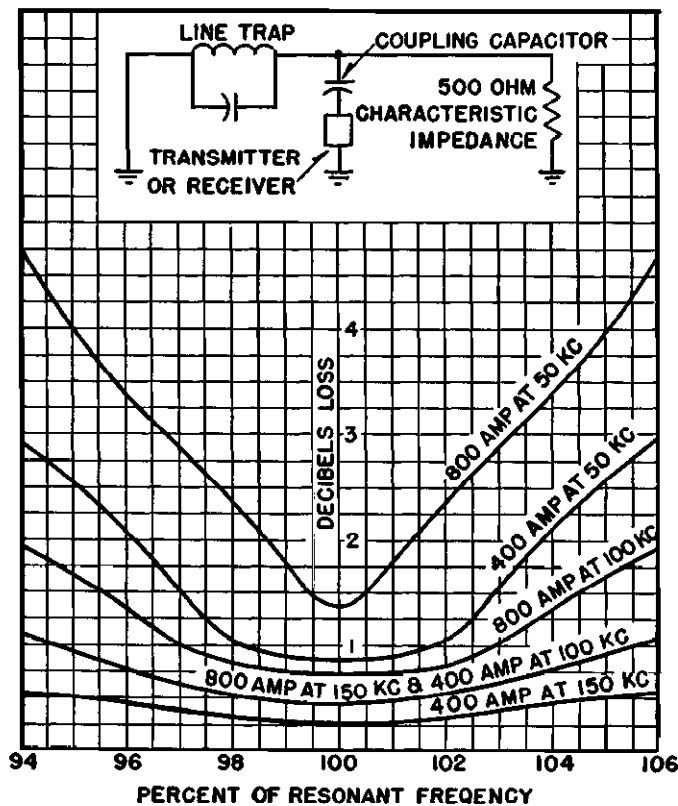

Fig. 24—Losses in typical 400- and 800-ampere single-frequency line traps when a line-to-ground carrier channel of 500 ohms characteristic impedance is short-circuited through them.

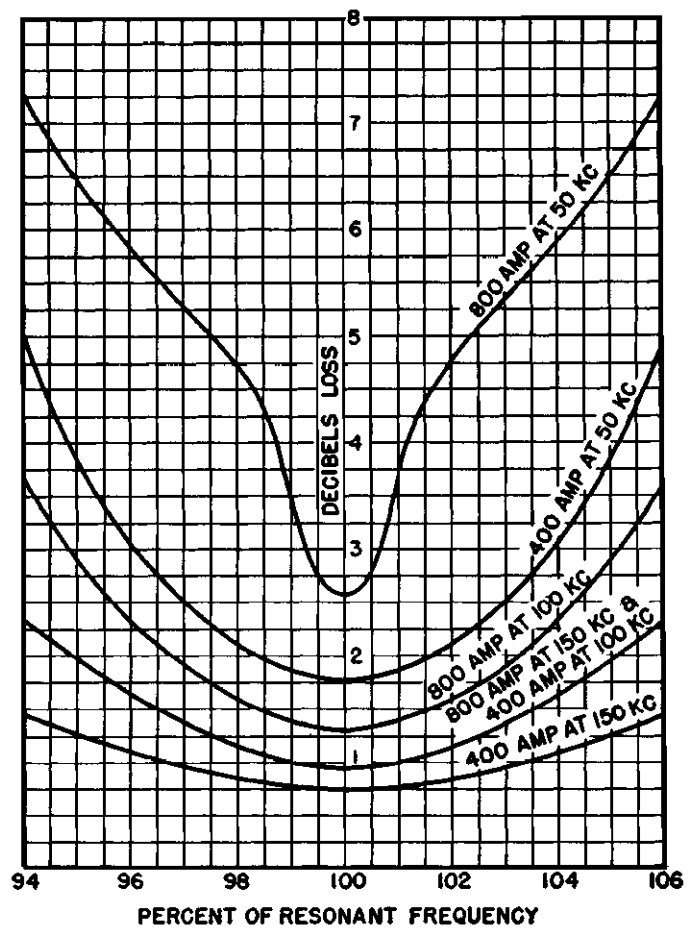

Fig. 25—Losses in typical 400- and 800-ampere double-frequency line traps when a line-to-ground carrier channel of 500 ohms characteristic impedance is short-circuited through them.

coupled phases. Two line traps, one in each phase conductor of an interphase coupled channel, are more effective in this regard. Even in this case, however, there is usually sufficient unbalance in the system at carrier frequencies to cause appreciable current in the unused conductor, with resulting interference to channels beyond the trap location. The installation of a line trap in each of the three phases of a line is the only effective way of isolating a channel for the purpose of reducing interference, regardless of the method of coupling used. For this method to be successful, there must be no important sources of coupling between circuits on opposite sides of the line traps. This means that these lines must extend in opposite directions from the trap location and must not be paralleled by untrapped lines. The degree of interference reduction obtained then is a function of the resonant trap impedance, the characteristic impedance of the lines in question, and the amount of coupling that remains between the ends of the circuits on opposite sides of the line traps.

32. Tuning Devices

The load resistances presented by power-transmission lines at carrier frequencies range from 400 to 900 ohms, and the reactances of coupling capacitors, which are effectively in series with this load, are appreciable and must be

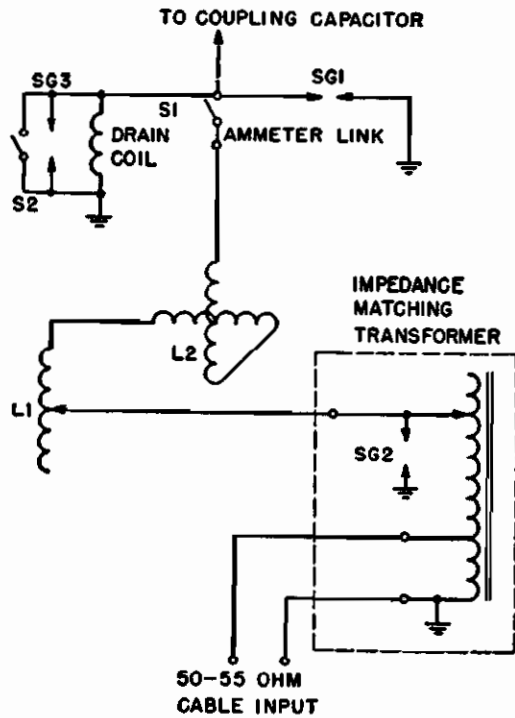

Fig. 26—Circuit diagram of single-frequency phase-to-ground line tuner. Switch S2, Gap SG3, and Drain Coil are omitted if included in coupling capacitor assembly.

compensated for if maximum coupling efficiency and a resistive load condition for the carrier transmitter are to be obtained. This compensation can be provided by placing in series with the capacitor an inductance that can be adjusted so that its reactance cancels the reactance of the coupling capacitance at the carrier frequency. The primary purpose of a line tuning unit is to furnish an adjustable inductance for this purpose. This inductance usually takes the form of a tapped main coil, which furnishes large steps in inductance, in series with a variometer that pro-

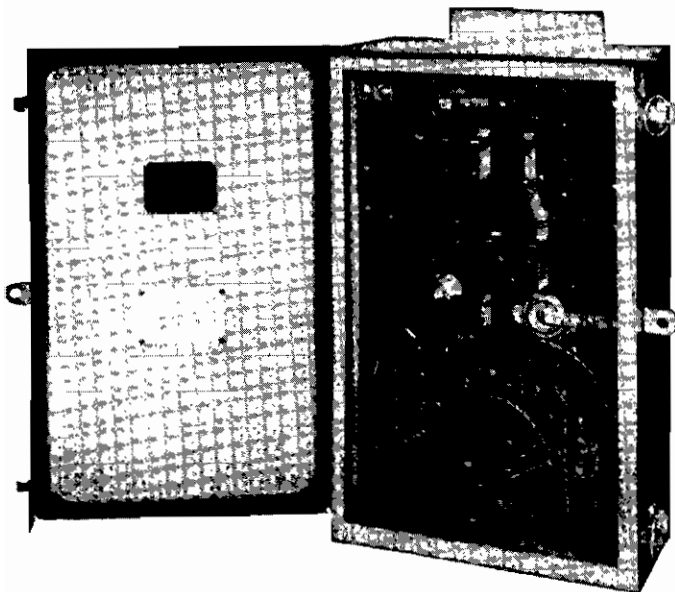

Fig. 27—Typical single-frequency phase-to-ground tuner.

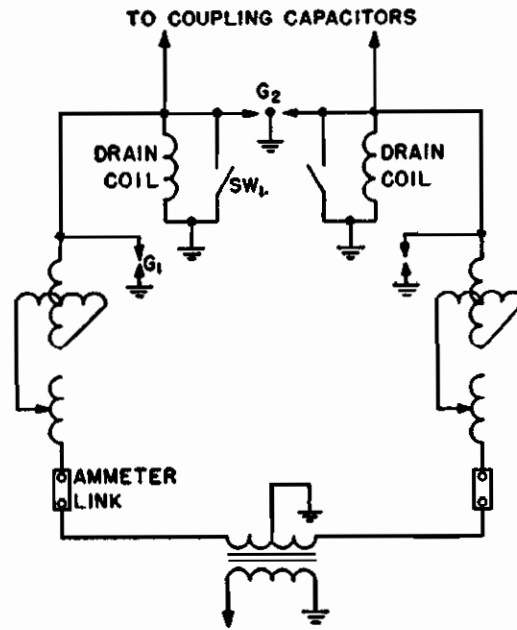

Fig. 28—Schematic diagram of an interphase single-frequency line tuner.

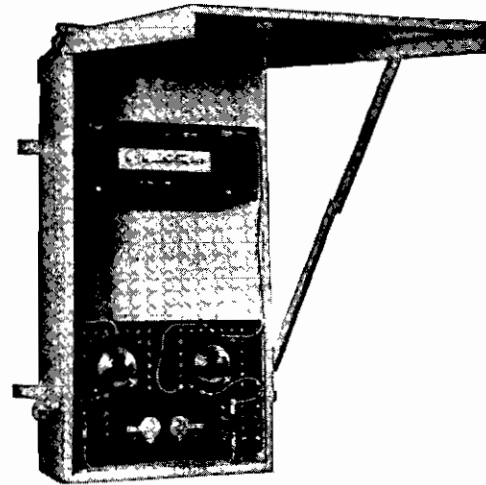

Fig. 29—A typical interphase line tuner.

vides a continuous range between tap values. Line tuners also include an impedance-matching transformer for transforming the characteristic impedance of the line to a value that properly terminates the coaxial cable commonly used between the carrier assembly and the line.

A schematic diagram of a typical single-frequency tuner, used to couple the carrier energy to a single phase conductor, is shown in Fig. 26. Figure 27 is a typical tuner of this type. Ground is used as the return circuit with this tuner. A protective gap is provided to prevent over-voltages from damaging the tuning inductances. The grounding switch is used to ground the lead from the coupling capacitor during inspection or adjustment of the tuner.

A phase-to-phase tuning unit is shown in Figures 28 and 29. In this unit two identical inductance coils and variometers are provided, one set for each capacitor. The

impedance-matching transformer is balanced to ground by means of a center tap on the line side.

33. Multi-Frequency Tuning

It is often necessary to provide for the coupling of more than one carrier frequency to a line at a given location. In such cases a worthwhile economy can be effected by the use of a multi-frequency tuning system, which permits a single coupling capacitor to be tuned to two separate carrier frequencies.

A schematic diagram of a two-frequency tuner for line-to-ground coupling is given in Fig. 30. The equipment consists essentially of two single-frequency tuners, in series

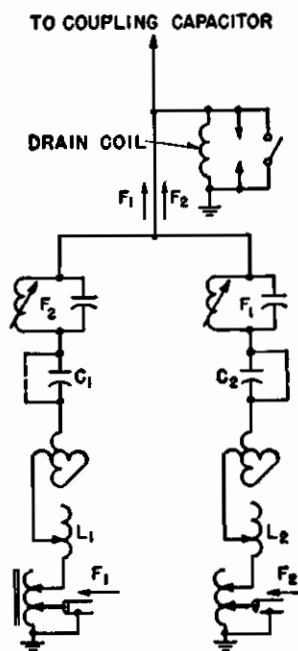

Fig. 30—Two-frequency line-to-ground tuning system with separate coaxial leads for each frequency.

with each of which a parallel-resonant trap circuit has been added. Each trap circuit is tuned to the carrier frequency which is to be passed through the tuning inductance in the opposite branch. Thus, if a frequency F_1 is to be passed through inductance L_1 , the trap circuit in series with the opposite branch is tuned to F_1 to prevent the carrier energy from being lost in that branch. Likewise, the trap circuit in series with the first branch is tuned to the opposite frequency F_2 to prevent loss of energy from source two. A photograph of a typical two-frequency tuner utilizing the system just described is shown in Fig. 31.

The trap circuits have appreciable reactance at frequencies off resonance, and for this reason the main series inductances cannot be finally tuned until the trap circuits have been individually adjusted to the proper frequencies. At frequencies below resonance, a trap circuit has inductive reactance that increases as the resonant frequency is approached. The branch that is to be tuned to the lower frequency, therefore, requires less inductance for overall series resonance than a single-frequency tuner used with

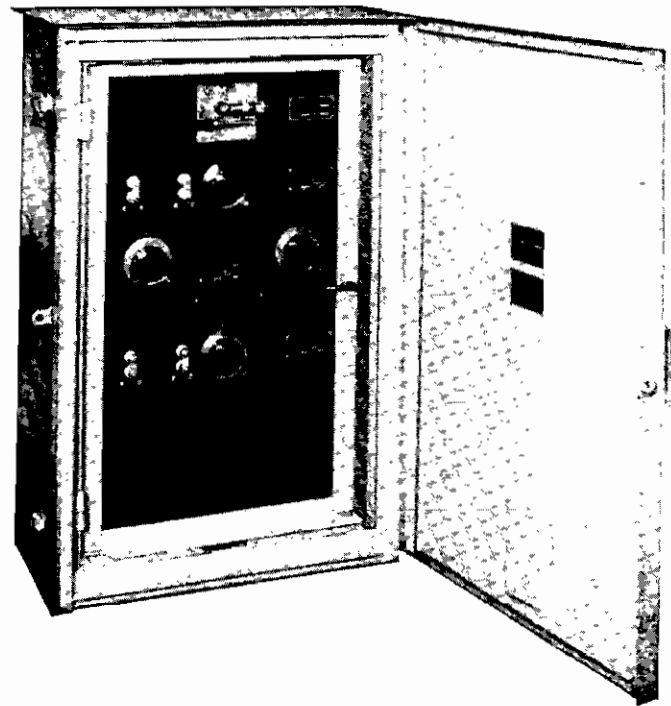

Fig. 31—A typical two-frequency line-to-ground tuning assembly of the type shown in Fig. 30.

the same coupling capacitor. Correspondingly, the branch that is to be tuned to the higher frequency requires more inductance than normal because the reactance of the associated trap circuit is capacitive. If the two frequencies are too close together, the additional reactances presented by the wave traps are so high that the overall series circuits cannot be tuned to resonance at the desired frequencies with ordinary tuning inductances. The separation required between the two frequencies depends upon the capacitance of the coupling capacitor and the inductance range available in the tuning inductances, but in general, the higher frequency must be at least 25 percent greater than the lower for satisfactory tuning with tuning inductances of the usual range. When the frequencies are too close to permit tuning as above, it is sometimes possible to obtain series resonance at the lower frequency by adding a fixed capacitor in series with the trap circuit to neutralize some of the excess inductive reactance obtained. This is the purpose of the fixed capacitors C_1 and C_2 shown in Fig. 30. It must be kept in mind that losses in the trap circuits increase rapidly as the frequency separation is reduced, however, so that every effort should be made to locate the channels in the spectrum with sufficient separation to avoid this expedient.

This system of multi-frequency tuning can be extended theoretically to handle as many separate frequencies as desired. For example, Fig. 32 illustrates a three-frequency system. In this case the trap circuits in each series leg are tuned to the frequencies of the opposite two legs. From a practical standpoint, however, it is generally inadvisable and uneconomical to attempt to tune a single capacitor to more than two frequencies. The complexity of the tuner and the difficulty involved in tuning it successfully to three

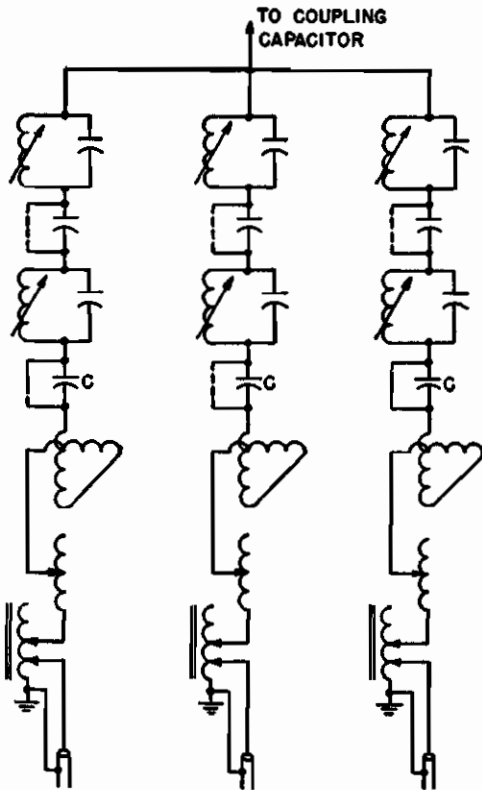

Fig. 32—Three-frequency tuning of a single coupling capacitor.

different frequencies nearly always outweighs any saving effected in equipment.

Another tuning circuit, which is series resonant to two frequencies and requires only a single co-axial lead, is shown in Fig. 33. The procedure for adjusting this circuit is to short-circuit the L_1C_1 combination and adjust L to series resonance with C at the higher of the two frequencies. With the short circuit removed, and with L_2 disconnected, L_1 and C_1 are then tuned to series resonance at the same frequency. L_1 and C_1 then effectively short circuit L_2 at the upper frequency, and its inductance, regardless of its value, has no effect at this frequency. At any lower fre-

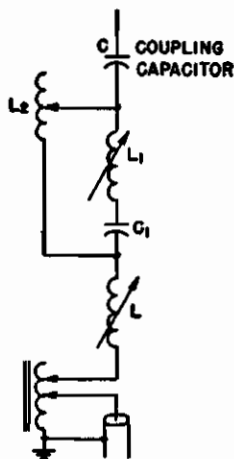

Fig. 33—A two-frequency tuning system requiring only a single coaxial lead.

quency, the L_1C_1 circuit shows a net capacitive reactance. This reactance is tuned in combination with L_2 to parallel resonance at a frequency intermediate between the upper and lower frequencies desired. Below this parallel resonant frequency, therefore, the $L_1C_1L_2$ combination appears inductive, the magnitude of the inductive reactance depending upon the intermediate frequency chosen. By varying this frequency by adjusting L_2 , the net inductive reactance of the $L_1C_1L_2$ combination in series with the main tuning inductance L can be made to tune the entire circuit to series resonance at the lower frequency.

If the double-frequency tuning scheme described above is used for coupling two transmitters to a line at a single location, trap circuits must be used at the transmitter output circuits to avoid the loading of one transmitter by the output circuit of the other when both work into a single coaxial cable.

34. Omission of Outdoor Tuning Equipment

On many carrier channels the terminal equipment is capable of operating through much greater attenuation than that introduced by the line itself. In such cases some economy in installation can be effected and greater convenience in making tuning adjustments can be provided by eliminating the usual outdoor tuning equipment and supplying equivalent units in the carrier assembly. In such cases the coaxial cable is usually connected directly to the coupling capacitor at the line terminal, as shown in Fig. 34. Some reduction in the resultant losses in the cable, due to the impedance mismatch at the junction of the cable and the capacitor, can generally be effected by using an impedance matching transformer at the coupling capacitor, as shown in Fig. 35. Such a transformer can make the terminating impedance equal in magnitude to the

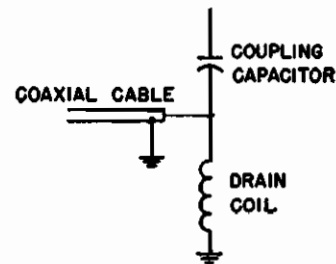

Fig. 34—Omission of outdoor tuner and matching transformer.

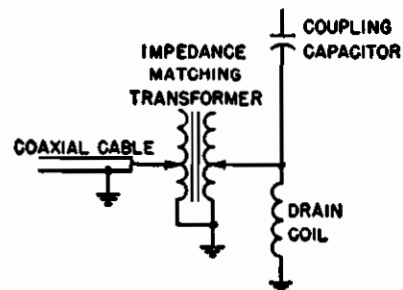

Fig. 35—Omission of outdoor tuner, matching transformer used to match absolute value of line and coupling capacitor impedance to coaxial cable impedance.

surge impedance of the cable, but it cannot compensate for the capacitive component of the combined line and coupling capacitor impedance.

The loss in a given length of coaxial cable in such installations is dependent upon the frequency involved, the reactance of the coupling capacitor, and the surge impedance of the line, as well as upon the characteristics of the coaxial cable itself. The curves of Fig. 36 show the meas-

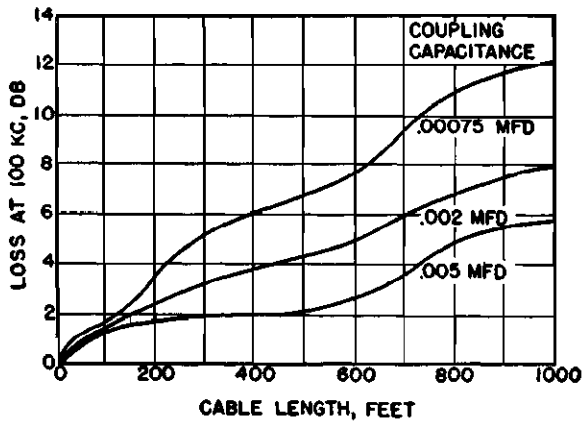

Fig. 36—Measured attenuation at 100 kc of various lengths of coaxial cable operating directly into 900-ohm resistive load through coupling capacitances shown. No impedance matching transformer used (Fig. 34).

ured db loss at 100 kc with various lengths of a typical coaxial cable, operating into a 900 ohm line through coupling capacitors of several different ratings. These curves apply for the case where no matching transformer is used at the coupling capacitor. For the case where a matching transformer is used, F. M. Rives¹⁵ has published similar data, giving the maximum length of coaxial cable permissible for given db losses at several different fre-

TABLE 2

Coupling Capacitance mfd.	Recommended Maximum Cable Lengths in Feet from Coupling Capacitor to Terminal Equipment Matching Transformer Used Without Tuning Equipment					
	For 1-db Attenuation			For 2-db Attenuation		
	50 kc	85 kc	150 kc	50 kc	85 kc	150 kc
.00075	150	180	200	300	350	410
.001	200	230	250	390	430	600
.0012	240	270	300	430	500	750
.0015	260	300	340	500	600	800
.002	360	390	460	680	800	1000
.003	450	450	475	900	1000	1000
.006	800	800	800	1000	1000	1000

quencies with various coupling capacitances. Table 2 is taken from Rives' paper.

The reactive and resistive components of the input impedance at the transmitter end of the coaxial cable vary radically with the frequency, the length of the cable, and

the terminating impedance in either of these systems. A conventional line tuner is not, in all cases, adequate to compensate for the reactances that may be encountered, nor are the impedance-matching transformers usually included in such tuners always capable of transforming the

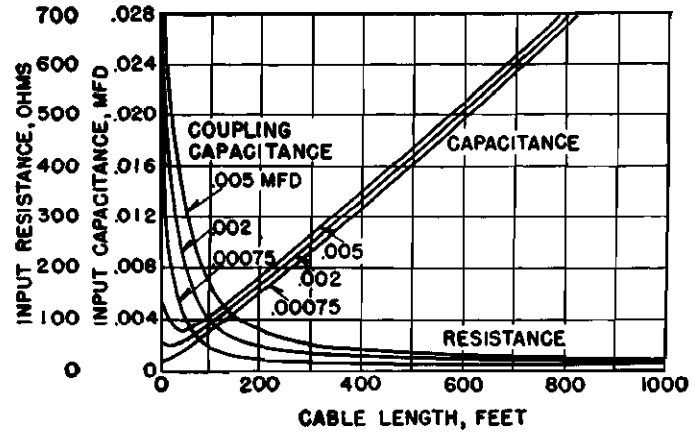

Fig. 37—Input resistance and capacitance ($R-jX_c$) at 100 kc of various lengths of coaxial cable operating directly into 900-ohm resistive load through coupling capacitances shown. No impedance matching transformer used (Fig. 34).

resistive component to the proper load resistance for the transmitter. Both the resistive and reactive components become very low as the length of the cable is increased up to a quarter wave. The input capacitance and resistance at 100 kc of a coaxial cable terminated in various capacitances and a 900-ohm line are shown in Fig. 37.

35. Carrier Coaxial Cable

It was common practice in the past to locate the carrier transmitter and receiver relatively close to the coupling capacitor and tuner, and to connect the assembly directly to the tuning inductance without impedance transformation at the tuner, as shown in Fig. 38. In such installations

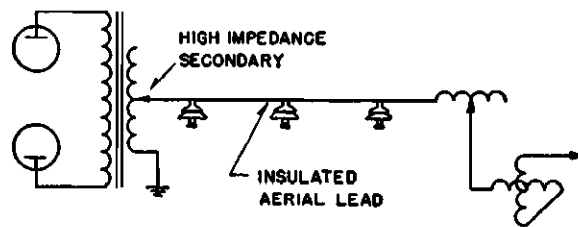

Fig. 38—Use of insulated aerial lead between carrier transmitter and outdoor tuner.

the lead between the carrier assembly and the tuner operates at line impedance level, and unless this lead is supported aerially and is well insulated, losses resulting from shunt conductance to ground becomes excessive in lengths over 100 feet or so.

Modern developments in solid-dielectric cables have resulted in practically complete abandonment of the practice of making the connection between the set and the tuner through a high-impedance lead. The losses in such cables, when they are properly terminated, is only about 0.5 db

per 1000 feet at carrier frequencies, and they can be run through conduit or buried directly in the ground without effect upon their performance.

The specification for a typical coaxial cable used in power-line carrier work is as follows:

The center conductor consists of a single-conductor 0.102-inch diameter (No. 10) soft-drawn, tinned copper wire. This conductor is covered with a continuous coating of 60 percent low-capacity rubber insulation making the outside diameter approximately 0.450 inch. Over this is a copper braid, equivalent in cross-section to the center conductor, made up of No. 30 tinned copper wire. Over this is a lead sheath $\frac{3}{4}$ inch thick with $\frac{3}{4}$ percent antimony. The outside diameter does not exceed 0.6 inch. The high-frequency loss does not exceed 0.32 decibel at 50 kilocycles, nor 0.60 decibel at 150 kilocycles. The surge impedance is approximately 60 ohms.

The measured characteristics of coaxial cable manufactured to these specifications were found to be as follows:

Surge impedance.....	61.1 / $-0^{\circ}29'$ ohms
Propagation constant.....	0.568
Attenuation at 150 kc.....	0.429 db/1000 feet
Resistance.....	3.91 ohms/1000 feet
Inductance.....	110.1 mh/1000 feet
Shunt conductance.....	519 micromhos/1000 feet
Shunt capacitance.....	0.0295 mfd/1000 feet

Similar coaxial cables with synthetic rubber or plastic jackets, instead of lead, are also widely used. The electrical characteristics are about the same.

36. Methods of Coupling

There are a number of different ways of utilizing one or more conductors of a three-phase power line as conductors for carrier-frequency currents. Some of these are illustrated in Fig. 39. The simplest of these, and by far the most popular, is to use a single conductor of the power line as one leg of the carrier circuit, with ground as the return path (Fig. 39a). This system, commonly called "line-to-ground," "phase-to-ground," or "single-phase ground-return" coupling, requires less coupling equipment (coupling capacitors and tuners) than any of the other methods shown, and it is universally used for short-haul, point-to-point channels, such as for relaying. On lines not provided with ground wires, the attenuation of a circuit using this method of coupling is higher than an equivalent length of circuit using line-to-line coupling, particularly if ground characteristics are unfavorable. Line noise is also somewhat greater. However, modern practice favors line-to-ground coupling for all except the longest and most important carrier channels.

The coupling system shown in Fig. 39b is variously termed "line-to-line," "phase-to-phase," or "interphase" coupling. This system was at one time used almost exclusively in preference to line-to-ground coupling for communication channels and most telemetering channels of any length, but in recent years has given way to some extent to line-to-ground coupling. At first glance this system appears to have the advantage that one of the conductors can be grounded at any point without interrupting the continuity of the carrier channel. However, in the line-to-ground system there is often sufficient electrostatic

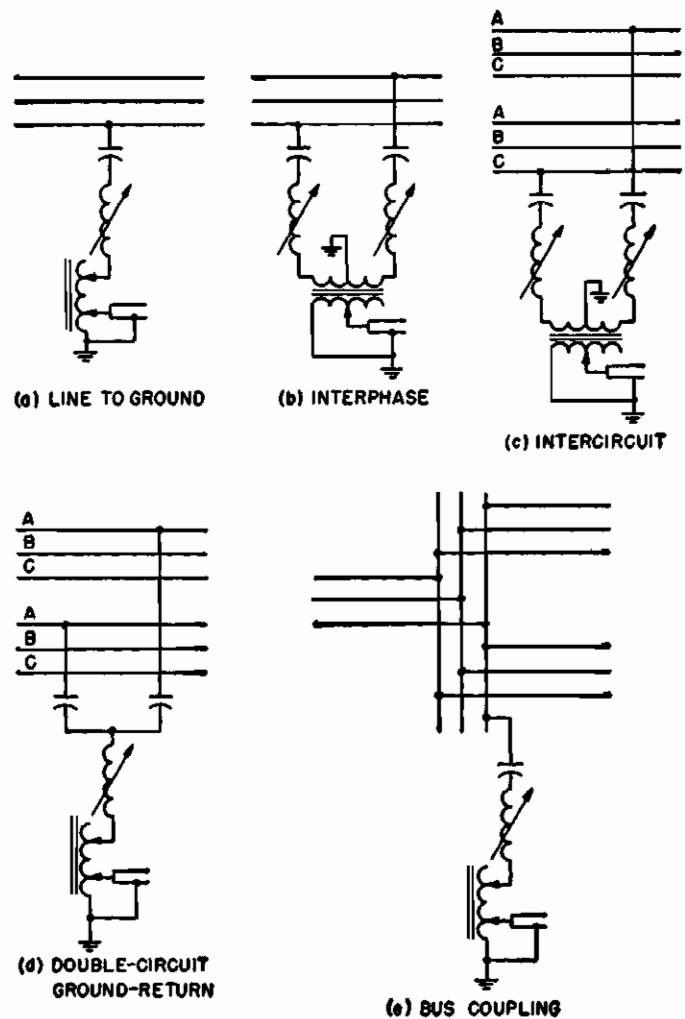

Fig. 39—Methods of line coupling.

and electromagnetic coupling between an open or grounded conductor and the two unaffected conductors to transfer enough energy around such a discontinuity to maintain a usable communication signal, provided the conductor is not opened or grounded closer than several hundred feet from the carrier terminal, and also provided that the channel normally operates with sufficient margin to take care of the increased signal-to-noise ratio. The secondary of the impedance-matching transformer used in the interphase system is usually center-tapped and grounded, and if one of the conductors is grounded close to the terminal, the output transformer may be partially short-circuited, resulting in a reduction of signal strength.

37. Inter-Circuit Coupling

If a double-circuit transmission line exists between carrier terminals, consideration can be given to several methods of coupling that increase carrier-circuit reliability under abnormal system conditions. One of these is inter-circuit coupling, shown in Fig. 39c. With this type of coupling either circuit can be taken out of service and all three phases can be grounded at any point without interrupting the continuity of the carrier circuit. In inter-circuit coupling, connection is made to one phase of one

circuit and to a *different* phase of the other. When both lines are in service and are bussed at both ends, this type of coupling is equivalent to interphase coupling. Inter-circuit coupling can be used only on a double-circuit line that cannot be sectionalized between carrier terminals.

38. Double-Circuit Ground-Return Coupling

In double-circuit ground-return coupling, Fig. 39d, the carrier signal is coupled to the same phase of the two circuits, and these operate in parallel under normal conditions with ground return. With this type of coupling either line can be taken out of service or sectionalized between terminals without interrupting the carrier channel. In fact, some installations use this type of coupling in which a portion of the intervening path between the terminals is a single-circuit line. It is generally possible with this type of coupling to ground one of the two circuits for maintenance without interrupting carrier service, provided the ground is not applied directly at the coupling capacitor location. Even in the latter case, if there is sufficient margin between the capability of the carrier sets and the normal attenuation of the circuit, it is often possible to keep the carrier channel in service.

39. Bus Coupling

Where it is desired to couple the carrier signal to several transmission lines simultaneously at a given location, bus coupling, Fig. 39e, is sometimes used. This system of coupling can be used either phase-to-ground or phase-to-phase. It is subject to several disadvantages, among them the fact that the opening of any circuit breaker on a given line between the two terminals, even at the terminals themselves, interrupts the carrier channel over that line. Also, if there are more than a few circuits connected to the bus, it may be impossible to locate a carrier frequency that can provide satisfactory operation under all system switching conditions, and the number of line traps required to isolate offending lines may eliminate the apparent economic advantage of bus coupling.

40. By-Passing of Carrier Signals

Carrier by-pass assemblies are used to provide a path for carrier energy around transformers, switches, circuit breakers, or other discontinuities that may exist in a carrier channel. By-pass assemblies consist essentially of one or more coupling capacitors and associated line tuning units. The capacitors are tuned to series resonance at the frequency or frequencies to be passed around the discontinuity. The following discussion specifically shows by-passing arrangements used with channels coupled line-to-ground, but it should be understood that similar arrangements utilizing twice the number of capacitors and tuning inductances can be applied on interphase channels.

41. Short By-Passes

The simplest type of by-pass assembly is that shown in Fig. 40, consisting of a single coupling capacitor and a single line tuner, both suspended in the line. This simple system is suitable only for by-passing transformers, regulators, and other such equipment that normally provides voltage on both sides of the by-pass assembly when either side

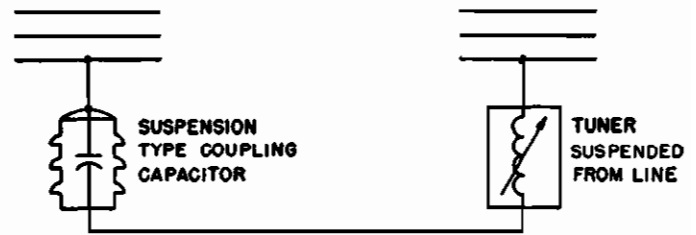

Fig. 40—Suspended by-pass arrangement.

is energized. It should never be used to by-pass disconnect switches or circuit breakers, or to pass signals from a line of one voltage to a line of another voltage, except at transformation points, because the ungrounded coupling capacitor can supply dangerous amounts of charging current from the energized side of an open switch or breaker to the apparently de-energized line.

The simplest by-pass assembly suitable for general application as a short by-pass is that shown in Fig. 41.

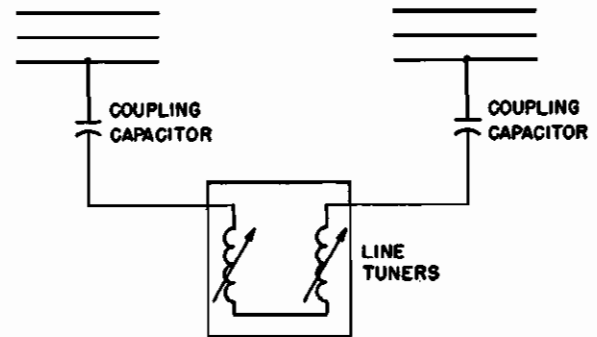

Fig. 41—Conventional short single-frequency by pass. One tuning inductance can be omitted in some cases.

Two coupling capacitors and a single tuning assembly, consisting of two tuning inductances, are used. The connections between the inductances and the capacitors are made with insulated aerial leads. No coaxial cable is employed. Since the leads between the capacitors and the tuning inductances operate at a high r-f potential, they must be extremely well insulated to prevent excessive losses due to shunt conductance. This system is not recommended for installations where the coupling capacitors are separated by more than 100 feet. The tuning inductances should be located as nearly midway between the coupling capacitors as possible.

For higher frequencies, or with lower-voltage lines where coupling capacitors of relatively higher capacitance are used, a single tuning inductance is often sufficient to tune both capacitors to resonance.

42. Long By-Passes

The most efficient of the commonly used by-pass arrangements is that shown in Fig. 42, in which a tuning inductance and impedance-matching transformer are located at each coupling capacitor, and coaxial cable is used as the link between them. With this arrangement the distance between the coupling capacitors can be as much as several thousand feet, depending upon the losses in the coaxial cable at the frequency involved.

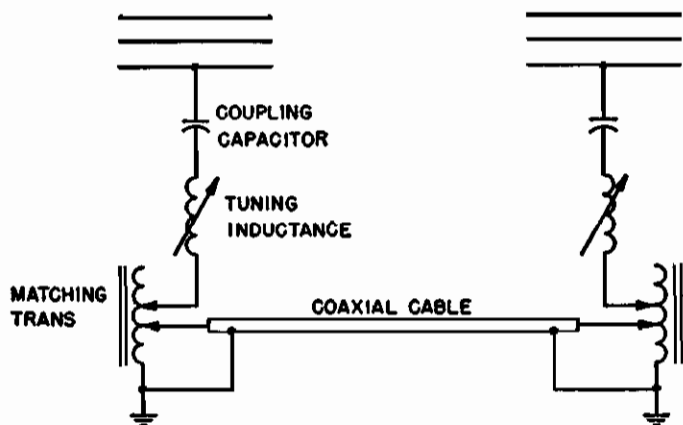

Fig. 42—Conventional long by-pass.

This type of by-pass actually amounts to two ordinary line tuning arrangements connected to operate into each other. If a carrier assembly is to be coupled into the line at the by-pass point, as might be desired on a multi-station communication system, the coaxial cable from each tuner is brought into the carrier assembly and connected to the low-impedance transmitter output tap usually provided for operation into two such cables in parallel. This arrangement is shown in Fig. 43.

This by-pass arrangement may be extended into a three-way system, as shown in Fig. 44, to pass signals from one line into two others. There is an inherent impedance mismatch in such a system at the junction of the three cables, as a result of the fact that each cable is terminated in one half its surge impedance. In addition to the 3-db loss in each direction due to the division of power between the two paths, there is a loss of about 0.5 db due to the mismatch at the junction.

43. Multi-Frequency By-Passes

All the multi-frequency tuning schemes shown in Figs. 30 to 33 can be applied in by-pass assemblies, so that more than one frequency can be passed. The arrangement shown in Fig. 30 is the easiest to tune and is the one most commonly used in such cases.

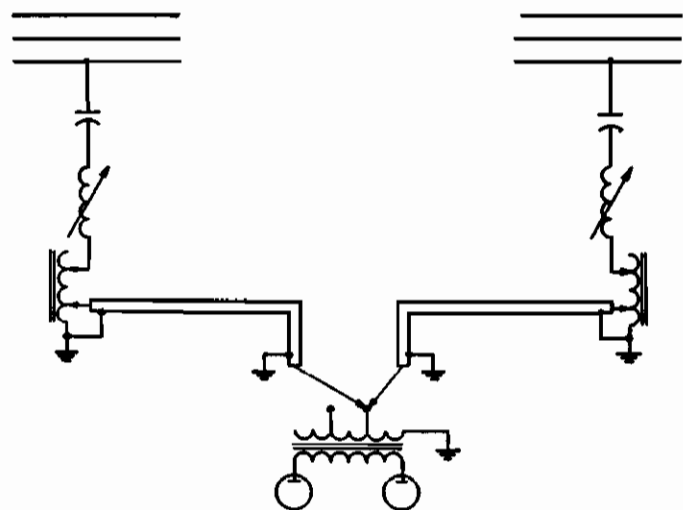

Fig. 43—By-pass with carrier terminal.

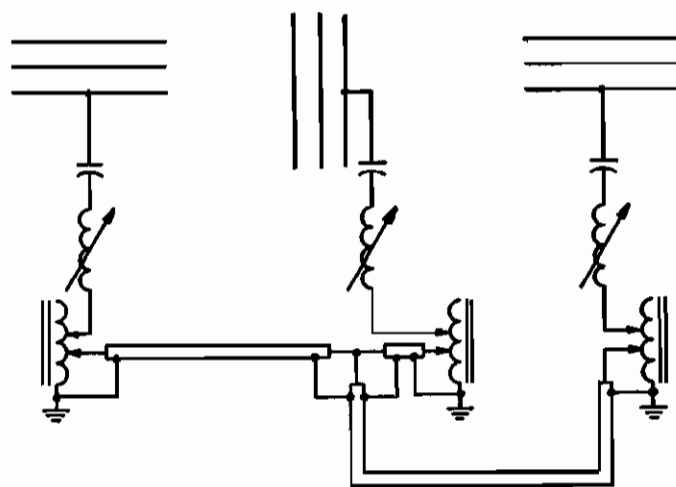

Fig. 44—Three-way by-pass.

Consideration has been given to the use of band-pass by-pass circuits, such as that shown in Fig. 45. In this case the coupling capacitors form a portion of the series arms of a simple "T" section band-pass filter. Many other such arrangements are possible.

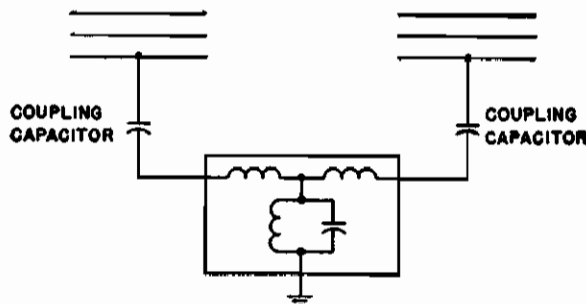

Fig. 45—Band-pass by-pass system.

VI. METHODS OF ESTIMATING CARRIER-CIRCUIT ATTENUATION

44. The Decibel

The decibel is a convenient unit for expressing the ratio between the power levels at two points in a communication system. This is because the actual ratios are often so large that their use is inconvenient on this account alone, and also because it is necessary to multiply the input and output power ratios for each individual component of the system to obtain the overall ratio. Losses and gains in decibels for individual components of a system can be added directly to give an overall loss or gain for the system.

The decibel is defined as 10 times the common logarithm of the power ratio, the ratio always being expressed as the quotient of the larger power by the smaller power; i.e.,

$$\text{db} = 10 \log_{10} \frac{P_1}{P_2} \text{ if } P_1 > P_2 \tag{12a}$$

or

$$\text{db} = 10 \log_{10} \frac{P_2}{P_1} \text{ if } P_2 > P_1. \tag{12b}$$

The ratio of two voltages or of two currents can be expressed in decibels as follows, *provided that the impedances of the circuits in which these voltages or currents exist are the same:*

$$\text{db} = 20 \log_{10} \frac{E_1}{E_2} \quad (13)$$

$$\text{db} = 20 \log_{10} \frac{I_1}{I_2} \quad (14)$$

Convenient decibel figures to remember are that a 2 to 1 power ratio is 3 db, 3 to 1 is 4.8 db, and 10 to 1 is 10 db. From these figures the number of decibels corresponding to 4-to-1, 5-to-1, 6-to-1, 8-to-1, and 9-to-1 ratios and any decimal multiples of these ratios can be estimated quickly by simple mental addition.

45. Decibel Rating of Carrier Assemblies

It is common practice to rate carrier transmitter-receiver assemblies in terms of the maximum number of decibels of attenuation through which two similar assemblies can operate satisfactorily. Actually these ratings are based on the assumption of noise levels at the receiving location that can reasonably be expected on a normal power system, and the decibel rating has been assigned on the basis of providing a satisfactory but undefined signal-to-noise ratio. This practice in rating carrier equipment unduly penalizes it when applications on relatively quiet systems are contemplated, because most equipment is capable on quiet lines of operating through much more than its rated attenuation. As more is learned about the nature and the magnitude of carrier-frequency noise on power systems, it is reasonable to expect that more informative ratings based upon the transmitter power and the receiver sensitivity and the response of the latter to noises of a given character and magnitude will come into practice.

46. Losses in a Carrier Circuit

The most common sources of attenuation in a power-line carrier circuit are:

1. Losses in coaxial cable between carrier assemblies and tuning units.
2. Losses in tuning and coupling equipment.
3. Losses in by-pass equipment.
4. Losses in straightaway transmission lines.
5. Losses due to discontinuities in transmission lines.
6. Losses due to division of energy (a) in long branch circuits at transmitting points, and (b) in long branch circuits remote from transmitting points.
7. Losses due to low impedance presented by untrapped spur lines.
8. Losses due to simultaneous propagation over alternate paths.

The total attenuation in decibels for an entire circuit is the sum of the decibel losses for each part of the circuit. A discussion of the attenuation that can be expected from each of the above sources follows.

Losses in Coaxial Cable—In practice an attempt is usually made to match the characteristic impedance of the transmission line to the impedance of the coaxial cable used between the carrier assembly and the tuning unit. An

TABLE 3—APPROXIMATE LOSSES IN COAXIAL CABLE

Frequency, kc	Loss, db per 1000 ft.
20	0.2
50	0.32
100	0.5
150	0.6
300	0.9

impedance matching transformer is provided for this purpose in the tuning unit. The losses in typical coaxial cable as a function of frequency when properly terminated are shown in Table 3. Typical losses in coaxial cable operating directly into a 900-ohm line without impedance matching or tuning are shown in Fig. 36.

Losses in Tuning and Coupling Equipment—It is possible to calculate accurately the losses in a tuning and coupling circuit, provided that the Q 's of the tuning inductance and the coupling capacitor and the characteristic impedance of the line are known. However, it is usually permissible for estimating purposes to assume a loss of one db for a simple tuner-capacitor combination working into an open-wire line.

Losses in tuning and coupling equipment working into a circuit of low characteristic impedance, such as a combination of several lines in parallel, or a power cable, are greater. An increase in coupling loss of one db can be assumed for each additional line at a transmitting point. In the case of power cables, an accurate calculation is desirable. The db attenuation of a single line tuner and coupling capacitor, applied to a power cable or other circuit of characteristic impedance Z_o , is

$$\text{db} = 10 \log_{10} \frac{Z_o + R_c(1 + Q_c/Q_L)}{Z_o} \quad (15)$$

in which R_c is the resistive component of the coupling capacitor impedance at the frequency considered, and Q_c and Q_L are the Q 's of the capacitor and the tuning inductance, respectively. A Q of 50 to 80 is typical for tuning inductances in the 50-150-kc band. For estimating purposes, a Q of 30 can be used for coupling capacitors.

The coupling loss for receiving is independent of the number of branch circuits at the coupling point, since in this case the carrier equipment is the terminating device for the coupling circuit. For estimating purposes, a receiver coupling loss of 1.0 db can be used.

The attenuation figures given above are based on single-frequency line-to-ground coupling and for estimating purposes can be doubled for interphase coupling. In the latter case, however, the characteristic impedance of the line is greater and the actual difference in attenuation is somewhat less.

The losses in two-frequency tuners are higher than those in simple single-frequency tuners. No accurate figures can be given, because the additional losses depend critically upon the Q 's of the inductances and the separation of the two frequencies involved. For a separation of 25 percent or more of the higher frequency, a loss of 2 db at each frequency can be used for estimating purposes on line-to-ground channels, or 4 db on interphase channels.

Losses in By-Pass Equipment—The losses in by-passing equipment are at least twice those of coupling equipment at a carrier terminal because two sets of coupling capacitors and tuners are involved. An interphase by-pass involves four times as much coupling equipment as a line-to-ground terminal, and the losses in this case can be assumed to be about four times as great, or 4 db. Losses in the coaxial between the two tuners must be added to these figures.

A factor that can increase the apparent loss in by-pass on a phase-to-ground circuit is that the carrier energy in a phase-to-ground channel tends to use the idle phases of the line as a return path. Since only the phase to which the carrier is directly coupled is normally by-passed, the opening of a by-passed circuit breaker interrupts the return path offered by the other two phases, and a greater increase in attenuation than that indicated by the loss figures previously given may be experienced. This is particularly true of phase-to-ground channels on lines not provided with ground wires.

In circuit-breaker by-pass installations involving long coaxial cable runs, it is occasionally found that the attenuation of the overall circuit is greater when the breakers are closed than when they are open. This can be explained as a case of attenuation due to simultaneous propagation over alternate paths, to be discussed presently. A remedy usually effective in this case is to reverse the phase of the current traveling through the by-pass circuit by reversing the connections to the impedance matching transformer in one of the tuners.

Losses in Transmission Lines—The attenuation of a straightaway transmission line at carrier frequencies is subject to many factors, such as the voltage of the line, which affects its construction and its insulation level, the type and the condition of the conductors and the insulators, the presence or absence of ground wires, the method of coupling used, weather conditions, and so forth. For this reason the attenuation figures given in Table 4 are neces-

TABLE 4—APPROXIMATE CARRIER ATTENUATION OF OVERHEAD POWER CIRCUITS

Line Voltage kv	Approximate Attenuation db per Mile									
	Phase-to-Phase Coupling					Phase-to-Ground Coupling				
	20 kc	50 kc	100 kc	150 kc	300 kc	20 kc	50 kc	100 kc	150 kc	300 kc
230	.03	.05	.075	.107	.2	.04	.062	.094	.13	.25
138	.041	.065	.09	.12	.215	.051	.081	.113	.15	.27
115	.05	.075	.102	.135	.27	.062	.094	.130	.16	.34
69	.055	.08	.11	.145	.29	.069	.100	.137	.18	.36
34.5	.073	.10	.13	.18	.38	.094	.125	.16	.22	.47
13.8	.12	.15	.18	.215	.45	.15	.19	.22	.27	.56

sarily only approximately correct. The figures for phase-to-ground coupling are 1.25 times those given for interphase coupling. On short lines (up to 50 miles) the attenuation may be greater, and on long lines it may be less, but the factor of 1.25 represents a good average. The figure of 0.1 db per mile is frequently used for preliminary estimat-

ing purposes regardless of the frequency, the line voltage, or the method of coupling.

Losses Due to Discontinuities in a Line—Any series or shunt impedance or physical condition at a given point in a line that causes the impedance seen looking into the line just ahead of the point in question to be different from the characteristic impedance of the line up to that point constitutes a discontinuity in the line. Discontinuities give rise to reflections and standing waves that cause increased losses in the line up to the discontinuity. In addition to these losses there may be losses in the device causing the discontinuity, with the net result that a discontinuity is a source of additional attenuation in a carrier channel.

When a discontinuity as defined above exists close to a transmitting point, so that a large fraction of the reflected energy returns to the transmitter, the line does not present its surge impedance as a load to the transmitter and may in fact present an impedance that is highly reactive in nature. In such cases it is necessary to compensate for the reactive portion of the line impedance by proper adjustment of the line tuner and to match the resulting resistive component of the load, which may be higher or lower than the characteristic impedance, by adjustment of the taps of the impedance-matching transformer in the tuner. Although the losses in the short section of line up to the discontinuity are greater than if the line were properly terminated, the increase is not serious except in extreme cases, and the only major loss, if any, is that in the device causing the discontinuity.

On the other hand, when a discontinuity exists at an intermediate point in a channel, sufficiently far from the transmitting point so that essentially the characteristic impedance of the line is presented to the transmitter, the loss in the line resulting from reflection at the discontinuity may be considerable.

Thevenin's theorem (see Chap. 10) suggests a general method of calculating the loss due to any discontinuity, either shunt or series, that exists in a carrier channel at a

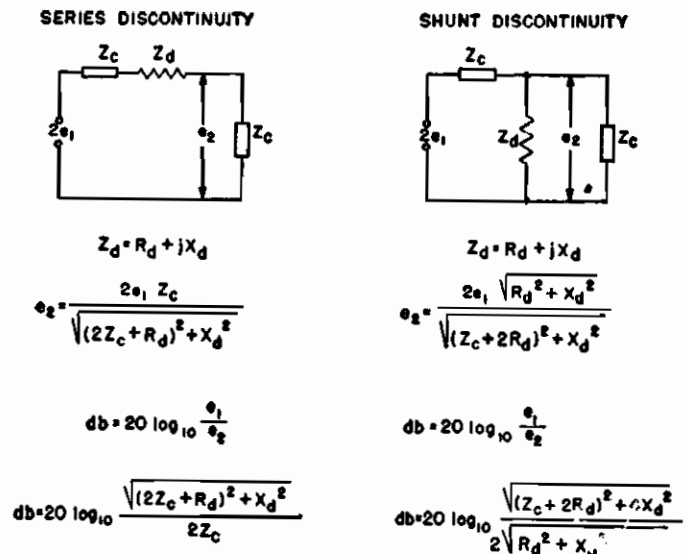

Fig. 46—Derivation of equations for loss due to series and shunt discontinuities in a long line.

point sufficiently remote from the transmitter. If the line were open circuited just ahead of the discontinuity, the voltage that would exist at the open circuited terminals would be twice the voltage that would exist across the line if it were continuous; i.e., if there were no discontinuity. Furthermore, if the line were short circuited at the transmitting point, the impedance seen looking into the open-circuited terminals back toward the remote source would be the characteristic impedance of the line. The system up to the discontinuity can be represented therefore by a voltage equal to twice the voltage that would exist with no discontinuity, in series with a resistance equal to the characteristic impedance of the line. If the discontinuity is a series impedance, it is placed in series with the characteristic impedance of the line beyond the discontinuity. If it is a shunt discontinuity, it is placed across the characteristic impedance of the line, and the combination is applied to the terminals of the equivalent network. These connections are illustrated in Fig. 46. The resulting loss, which includes the loss due to reflection as well as that in the device causing the discontinuity, is then expressed for a series discontinuity as

$$\text{db} = 20 \log_{10} \frac{\sqrt{(2Z_c + R_d)^2 + X_d^2}}{2Z_c} \quad (16)$$

and for a shunt discontinuity as

$$\text{db} = 20 \log_{10} \frac{\sqrt{(Z_c + 2R_d)^2 + 4X_d^2}}{2\sqrt{R_d^2 + X_d^2}} \quad (17)$$

In both of these equations

R_d = Resistive component of impedance of discontinuity

and X_d = Reactive component of impedance of discontinuity.

In the derivation of these equations it is assumed that the characteristic impedance of the line is the same on both sides of the discontinuity.

Losses Due to Long Branch Circuits—When a carrier transmitter is coupled to a power system at a point from which several long untrapped transmission lines radiate, the load impedance presented to the carrier equipment is the parallel of the characteristic impedances of the lines involved. The impedance matching transformer in the line tuner can usually be adjusted so that this impedance is transformed to load the transmitter properly, so that there is no reflection loss. However, the division of the energy

TABLE 5—LOSSES DUE TO LONG BRANCH CIRCUITS AT TRANSMITTING POINTS

1 additional circuit	3.0 db
2 additional circuits	4.8 db
3 additional circuits	6.0 db
N additional circuits	$10 \log_{10} (N+1)$ db

among the several circuits in effect constitutes an attenuation of energy along the desired path. If the characteristic impedances of all the lines involved are the same, the losses at a transmitting terminal in this case are as shown in Table 5. It should be noted that these losses are correct for a transmitting terminal only. If one or more long un-

trapped lines radiate from an intermediate point in a carrier channel, or from a receiving point, there is a loss due to reflection as well as a loss due to division of the energy among the circuits. Treatment of this case as a shunt discontinuity, by methods previously outlined, yields the results given in Table 6.

TABLE 6—LOSSES DUE TO LONG BRANCH CIRCUITS REMOTE FROM TRANSMITTING POINTS

1 additional Circuit	3.5 db
2 additional Circuits	6.0 db
3 additional Circuits	8.0 db
N additional Circuits	$20 \log_{10} \left(\frac{N+2}{2} \right)$ db

Losses Due to Short Untrapped Branch Lines—

As contrasted with the long branch lines just considered, short untrapped spur lines (in general, lines less than 50 miles in length) may present shunt impedances differing radically from the characteristic impedance of the line. If the terminating impedance and the length of a spur line are known accurately, it is feasible to calculate the impedance such a spur line presents at its input terminals at a given frequency. This impedance can then be considered as a shunt discontinuity and treated by the method previously given. Fig. 12 shows the absolute value of the input impedance of a typical line ($Z_c = 730$ ohms, attenuation 0.186 db per wavelength) as a function of various capacitive reactance terminations.

Data on the carrier frequency impedance of power transformers and other terminating devices are not generally available, however, and it is not usually possible to calculate the input impedance of a spur line. If after installation of the equipment a carrier frequency cannot be chosen that will maximize the spur-line impedance, it may be necessary to install line traps to isolate the spur line from the carrier channel. In this case the effect of the spur line upon the attenuation is reduced to a low value, depending upon the characteristics of the line trap.

Losses Due to Simultaneous Propagation Over Alternate Paths—A carrier channel that includes two alternate paths may suffer attenuation due to out-of-phase arrival at a common point of signals traveling over the two paths. The magnitude of this attenuation is highly variable, depending upon the nature of the two paths, their relative individual attenuations, and the frequency used. Limiting attenuation figures can be established, however, for certain cases in which one or both of the alternate paths are long (over 50 miles).

If both paths are long, there is a loss of 0.5 db at the branch point due to reflection. The relative amplitudes and the phase of the two signals arriving at the junction of the paths determines the additional attenuation. Specific cases are as follows:

Equal Amplitudes, In-Phase Arrival—Reflection losses of 0.5 db at junction and at branch point due to impedance mismatch. Total attenuation from branch point to junction 1.0 db plus attenuation of one path.

Equal Amplitudes, Out-of-Phase Arrival—Cancellation of voltage at junction, infinite attenuation. This is an unlikely condition because two long alternate paths having

exactly the same attenuation are rarely encountered. The attenuation may still be large in practical cases, however, as pointed out below.

Unequal Amplitudes, In-Phase Arrival—Maximum loss at junction 3.5 db. Total maximum loss 3.5 db at branch point due to reflection and division of energy, plus 3.5 db maximum at junction, plus attenuation of shorter path. These maximum losses are based on complete attenuation of the signal in the longer path.

Unequal Amplitudes, Out-of-Phase Arrival—Minimum loss at junction 3.5 db, increasing with decreasing differ-

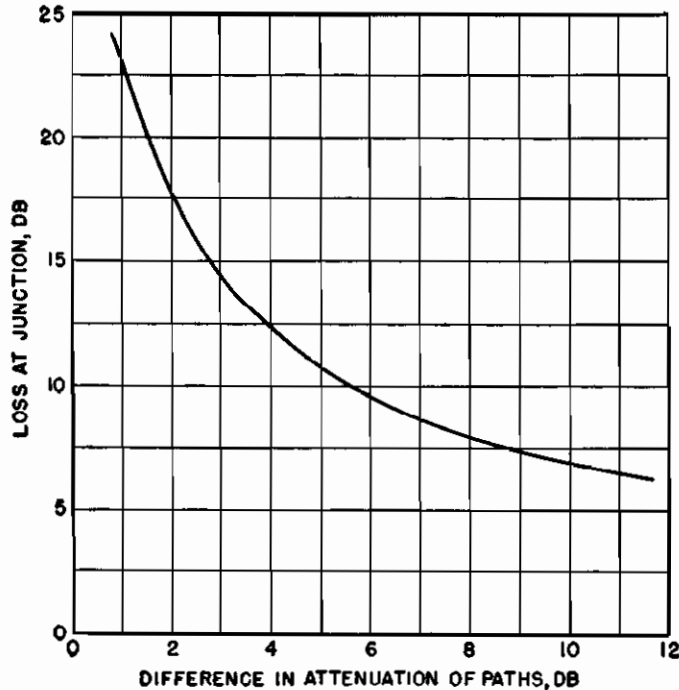

Fig. 47—Loss due to out-of-phase arrival of signals at a junction of two long alternate paths. This curve gives loss at the junction only and does not include the loss at the branching point or the loss in the paths themselves. The junction is assumed to be terminated by a single line which is a continuation of the channel.

ence in attenuation of the two paths, as shown in Fig. 47. To these losses must be added 0.5 db loss at the branch point due to reflection and 3 db due to division of energy, plus the attenuation of the shorter path.

If both paths are short and of unequal length, the attenuation may be very great, particularly if one of the paths is a half wavelength longer than the other.

In general, if the frequency cannot be adjusted after installation to avoid out-of-phase arrival at a junction, it may be necessary to resort to the use of line traps to eliminate alternate paths. A long alternate path, when trapped at one end only, reduces to the case of a single long branch circuit, for which the attenuation is 3.5 db. A short alternate path may require trapping at both ends for reduction of the attenuation to an acceptable value, because a trap installed at one end only may reduce the situation to that of a short untrapped spur line, for which the attenuation may still be excessive.

47. Example of Calculation of the Total Attenuation of a Typical Carrier Circuit

The typical system of Fig. 48 will be used to illustrate the application of the principles just discussed in estimating the attenuation of a carrier channel. In this example a 100 kc line-to-ground-coupled carrier channel is to be established between Stations A and C, and the losses are to be estimated for transmission in each direction.

At Station A there are three long circuits on the 138-kv bus in addition to the circuit over which carrier is to be transmitted. These cause a loss of 6 db because of division of the energy among the total of four circuits (Table 5). They also cause an additional coupling loss because the coupling circuit is working into a load impedance lower than normal line characteristic impedance. This additional coupling loss is estimated at 1 db for each additional circuit, or 3 db, plus the normal 1 db coupling loss.

All line losses are estimated from Table 4.

The branch circuit loss at Station B is 6 db, as given by Table 6, because this station is remote from the transmitting point.

The by-pass loss at Station C is twice the loss of a terminal coupling circuit, or 2 db, plus 0.5 db loss for 1000 feet of coaxial cable at 100 kc (Table 3).

The loss in the trap on the short line out of Station C is approximately 0.5 db, as shown in Fig. 24 for a 400-ampere trap terminated in zero impedance.

There is an alternate path between Station C and Station D which has approximately 7 db greater attenuation than the direct path. From Fig. 47 the maximum possible loss, which would occur with out-of-phase arrival of the signals at Station D, is estimated as 8.5 db. To this must be added a loss of 3 db due to division of energy between the alternate paths at Station C, plus a reflection loss of 0.5 db at this point, a total attenuation of 12.0 db due to the presence of the alternate route. These figures do not include the 5.5 db attenuation of the direct path, which is added separately.

The long line extending beyond Station D serves as a terminating impedance for the circuit. Most modern carrier transmitter-receiver assemblies present an impedance of 5 to 10 times the load impedance into which they are intended to work, and as a result they do not serve to terminate a line in its characteristic impedance. If the line beyond Station D were not present, there would be a slight gain in voltage received at Station D because of the high terminating impedance.

There is an estimated 1 db coupling loss for receiving at Station D, plus 0.25 db coaxial cable loss. The total attenuation of the channel for transmission from Station A to Station D is the sum of all the losses discussed. These are summarized and added in Fig. 48, giving a total attenuation of 52.2 db for the channel.

For transmission from Station D to Station A, there is a 4.8 db loss at Station D due to division of energy among the three lines on the bus, and an increase of 2 db in the coupling loss. The additional loss due to the alternate path in this case is 8.5 db at Station C. At Station A, one of the branch lines can be considered as a continuation of the main line. The other two branch lines cause 6 db attenuation, partly due to reflection and partly due to division of

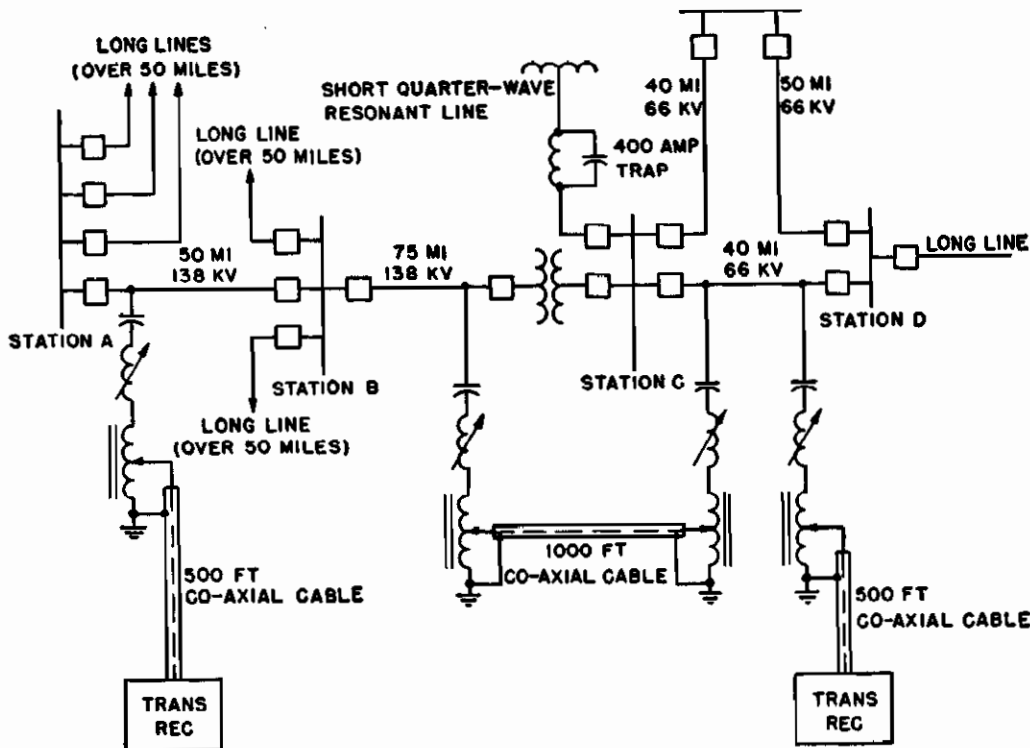

SUMMARY OF LOSSES

	STATION A TO STATION D	STATION D TO STATION A
1. CO-AXIAL CABLE LOSS AT STATION A	0.25 db	0.25 db
2. COUPLING LOSS AT STATION A	1.0	1.0
3. ADDITIONAL COUPLING LOSS CAUSED BY BRANCH CIRCUITS	3.0	
4. BRANCH CIRCUIT LOSS AT STATION A	6.0	6.0
5. LOSS IN 50 MILE 138 KV LINE	5.7	5.7
6. BRANCH CIRCUIT LOSS AT STATION B	6.0	6.0
7. LOSS IN 75 MILE 138 KV LINE	8.5	8.5
8. BY-PASS LOSS AT STATION C	2.0	2.0
9. CO-AXIAL CABLE LOSS AT STATION C	0.5	0.5
10. LOSS IN TRAP ON SHORT LINE AT STATION C	0.5	0.5
11. LOSS DUE TO ALTERNATE PATH FROM STATION C TO STATION D (MAXIMUM)	12.0	8.5
12. LOSS IN 40 MILE 66 KV LINE	5.5	5.5
13. COUPLING LOSS AT STATION D	1.0	3.0
14. BRANCH CIRCUIT LOSS AT STATION D		4.8
15. CO-AXIAL CABLE LOSS AT STATION D	0.25	0.25
TOTAL ATTENUATION	52.2 db	52.5 db

Fig. 48—Typical system assumed for example of calculation of losses, and summary of attenuation in each direction.

energy. The coupling loss for receiving is estimated as 1 db. All other losses in the channel are the same as for transmission from Station A to Station D. The total attenuation of the channel for transmission from D to A is therefore 52.5 db.

GENERAL CONSIDERATIONS IN APPLYING CARRIER SYSTEMS

48. Trapped Channels vs. Broadcast Systems

From the discussion just given of the sources of attenuation to carrier in a power system, it is evident that successful operation of a proposed carrier channel on a specified frequency can be assured only if spur lines, short

alternate paths, and other causes of high attenuation are eliminated from the channel by means of line traps. A clean, well-trapped channel delivers a reliable signal at the receiving point on any carrier frequency that may be available for use, regardless of system switching conditions.

As a result of the crowding of the carrier frequency spectrum on most interconnected power systems in this country, it is seldom that any appreciable latitude is available in the choice of a frequency for a new channel. Where a choice is available, however, it is sometimes possible to install carrier equipment on a system with little or no trapping and to experiment with different frequencies until one is found which permits successful transmission between the carrier terminals under all anticipated system switching conditions. In this case the carrier energy is "broad-

cast" throughout the power system, and the signal delivered to the intended receiving point is inherently weaker and less reliable than that delivered over a clean channel. Frequently it is impossible to find on a complicated system a frequency that permits successful operation of a "broadcast" type of channel. In this case it is necessary to seek out the sources of high attenuation and to isolate them one by one until a workable channel is obtained on an available frequency.

It is clear, therefore, that a trapped channel is preferable to a broadcast type of channel from the standpoint of reliability, ease of application, improved signal-to-noise ratio, and reduced interference to neighboring systems.

49. Frequency Assignments and Separations

One of the most important problems in the application of carrier equipment is the determination of the minimum frequency separation required between channels on the same system and the assignment of frequencies to new channels in a manner that permits maximum conservation of the available spectrum space.

In general, it is advisable to assign the lower frequencies in the spectrum to long-haul communication and telemetering channels, and to use the higher frequencies, which are attenuated more rapidly, for short channels. Relaying channels in particular are well suited to operation on the higher frequencies because they are always trapped at both ends and extend over only one line section. There are cases of successful application of relaying systems on identical frequencies on well-separated line sections on the same power system.

The frequency separation required between carrier channels on a power system is a function of a number of factors, such as the selectivity of the receivers employed, the relative strengths of desired signals and interfering signals at a receiving point, the type of modulation used, and the purposes for which the channels are applied. The last factor determines approximately the signal-to-interference ratio that can be tolerated. For these reasons no generally applicable figures for required separations can be given and each case must be considered individually.

Other factors being equal, single sideband channels can be spaced closer together in the spectrum than channels using other types of modulation. This results primarily from the increased receiver selectivity permissible in the reception of single sideband signals. The narrow bandwidth occupied by single sideband channels is also an important factor in determining required frequency separations between them and other types of channels, although the selectivity of the receivers used in the other channels is the limiting factor in determining the permissible reduction of the separation in this case.

The signal-to-interference ratio acceptable in a given type of service is to some extent a matter of opinion, and in addition it depends critically upon the adjustment of the equipment in most applications. Hence it is difficult to set down specific figures for various cases. Discussion of a few of the considerations involved, however, will aid in establishing acceptable figures for a given application, and Table 7 can be used as a guide.

In telegraph-type channels, in which the operation or

TABLE 7—RATIO BETWEEN MINIMUM SIGNAL RESPONSE AND MAXIMUM INTERFERENCE RESPONSE ON CARRIER RECEIVERS FOR VARIOUS APPLICATIONS

†Keyed Carrier Telemetering	†Carrier Relaying or Supervisory Control	Tone Telemetering	*Voice Communication
15 db	20 db	15 db for a single received tone, $(15 + 20 \log_{10} N)$ db for multiple tones, where N is the number of tones.	15 db minimum on automatic simplex systems. 10 db tolerable for short periods on other systems. 20 db good 30 db excellent

†Receiver sensitivity set so that receiver detector is barely saturated on minimum signal.

*Receiver sensitivity set so that minimum signal is at lower end of avc range. On automatic simplex systems, no greater transfer unit r-f sensitivity should be used than that required to give reliable operation on minimum signal.

non-operation of a receiving relay is the criterion of the effect of interference, it is necessary only to allow a reasonable margin of safety for relay drop-out in specifying the maximum interference level. A 2 to 1 ratio is a reasonable margin for telemetering purposes. If the telegraph receiver sensitivity is set so that the *minimum* expected value of the desired signal just causes saturation of the detector plate current, the maximum response of the receiver to an interfering signal should not exceed half the relay drop-out current. In the usual saturated-detector type receiver, this ratio is 12 to 15 db.

Although the same type of equipment is used for relaying purposes and frequently for supervisory control, the consequences of an incorrect relay operation in these applications are more serious and hence an additional factor of safety of 5 db has been allowed in Table 7 for these functions.

In tone telegraph service, such as tone telemetering, the carrier signal is normally on continuously, and the receiver sensitivity setting is not so critical, provided that the receiver operates on the flat portion of the avc (automatic volume control) characteristic over the entire range of variation in signal strength. The maximum signal-to-interference ratio that can be tolerated for a received carrier modulated 100 percent by a single tone is the same as that for keyed carrier reception, or 15 db, because the saturation characteristics of tone receivers are similar to those of saturated-detector carrier receivers. Additional margin must be allowed for modulation by more than a single tone, however, because the permissible percentage of modulation by each tone is reduced as the number of tones is increased. This is equivalent to a reduction of signal strength at the input of the tone receivers, and their sensitivities must be increased accordingly. Hence a formula which provides an allowance for additional tones is given in Table 7.

It is difficult to give actual figures for voice communication circuits, because there are widely different opinions as to what constitutes a "usable" channel or a "good" channel. Although it is possible to convey intelligence over a

voice channel in which the signal-to-interference ratio is nearly unity, a ratio of 10 db is about the minimum that can be tolerated for any length of time. A 20-db ratio is considered good and a 30-db ratio excellent by most users. The nature of the interference also is a factor on communication channels. For example, the psychological effect of speech interference of a given level is greater than that of interference of other types at the same level.

In automatic simplex channels, there must be adequate margin between the response of the receiver to the desired signal and its response to the interfering signal when the desired signal is absent, to permit reliable operation of the transfer unit. In such systems the receiver sensitivity should be set so that desired signals just cause operation on the flat portion of the avc characteristic when allowance is made for maximum attenuation. A minimum of 10 db difference between response to interference and response to such signals should then be allowed. Because of residual avc action, this requires about 15-db attenuation of the interference in typical receivers. Hence, automatic simplex channels should not be expected to operate reliably with smaller signal-to-interference ratios than 15 db.

The first step in the process of estimating required frequency separation is to calculate the relative strengths of the desired and undesired signals at the receiving point or points. This can be done by methods outlined in the sections of this chapter devoted to estimating attenuation. The relative carrier powers of the signals at the receiver are the original transmitter carrier outputs reduced by the attenuation of the respective paths of the signals to the receiving point in question. This establishes a signal-to-interference ratio at the receiver input terminals. The difference between this ratio and the required signal-to-interference ratio must be made up by the selectivity of the receiver. The separation required for this purpose can be determined by reference to the selectivity curve of the receiver at the particular frequency in question. Consideration must be given to the bandwidth of the interfering signal. This depends upon the type of service for which it is employed and the modulation system used. For example, an interfering a-m voice communication signal occupies a bandwidth extending approximately 3 kilocycles on each side of the carrier frequency and requires correspondingly greater separation from the desired signal than a carrier signal which is keyed for telemetering purposes and occupies a band of only a few cycles on each side of the carrier frequency. If the interfering channel is a single sideband voice channel, its bandwidth extends three kilocycles below the carrier frequency if the lower sideband is used, or three kilocycles above it if the upper sideband is transmitted. The suppression of the unused sideband can be assumed to be a minimum of 20 db.

The following is an example of the use of the principles discussed in determining required frequency separation for a typical case:

On a 100-kc voice communication channel having 50-db attenuation under extreme conditions, transmitter carrier power is 25 watts, and a receiver having the selectivity curve of Fig. 49 is used. A new a-m voice channel is to be added to the system. The transmitters in the new system will have a carrier output of 2.5 watts and the minimum attenuation between

any transmitter of the new channel and any receiver of the original channel is 10 db. What is the minimum frequency separation required to give a 20 db signal-to-interference ratio in the original channel?

The signal to interference ratio at the input terminals of the receiver is minus 30 db (10 db difference in transmitter power and 40-db difference in attenuation). Therefore 50 db of interference rejection is required for a 20-db signal-to-interference ratio. According to Fig. 49, signals

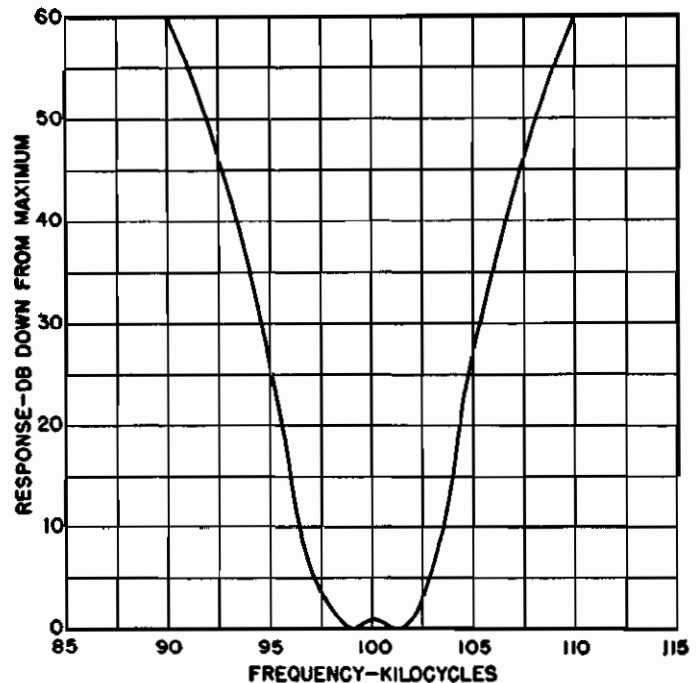

Fig. 49—Typical a-m receiver selectivity curve.

at 108 kc and at 92 kc are attenuated by this amount when the receiver is tuned to 100 kc. Allowing 3 kilocycles for sideband components of the interfering signal, the minimum separation of the carrier frequency of the new channel from that of the original channel is 11 kc above it or 11 kc below it. These are safe figures for either duplex or automatic simplex channels, provided that in the latter case the receiver sensitivity is adjusted properly. By a similar process, the separation required to provide a 20-db signal-to-interference ratio in the new channel can be estimated. Either the figures so obtained or those previously calculated, whichever are the larger, determine the separation required to maintain a minimum of 20-db signal-to-interference ratio in both channels.

50. Signal-to-Noise Ratio

Minimum tolerable signal-to-noise ratios for various carrier applications parallel closely the values of minimum signal-to-interference ratios given in Table 7, provided that the proper characteristic of the noise (e.g. peak amplitude, average amplitude, etc.) is considered in establishing these ratios for each application. The receiver bandwidth also must be considered in most applications, because noise response is usually a function of bandwidth.

In keyed-carrier telemetering applications, the average rectified noise output of the receiver is a measure of the

interfering properties of the noise. For impulsive interference with pulses separated sufficiently to prevent overlapping of the resulting wave trains, the average output is independent of the receiver bandwidth, and hence bandwidth does not enter into the picture in such applications. The area of the impulses is the major determining factor.

The same comments apply to carrier relaying, although in this case trouble from noise is not likely to be encountered. Because of the limited extent of carrier relaying channels, and the fact that they are always trapped at both ends, signal-to-average-noise ratios at receiving points are practically always far above the 20-db minimum. A possible exception is the case of three-terminal lines in which one leg of the circuit is approximately an odd number of quarter wavelengths at the frequency used.

For supervisory control by keyed carrier, the 20-db ratio given by Table 7 should be maintained between minimum signal and average noise.

In tone telegraphic functions (e.g. telemetering) the narrow bandwidth of the tone receivers reduces their response to random noise to negligible amounts. In addition to this factor, the wave trains resulting from impulsive noise with 60- or 120-cycle pulse-frequency overlap to a considerable extent in tone receivers of the usual narrow bandwidth. Under these conditions the average rectified noise output is less than that obtained with broadly tuned circuits. The actual reduction is a function of the bandwidth of the tone receivers, which in turn is usually a function of the tone frequency itself. However, the formula given in Table 7 can be used as a guide to the maximum permissible signal-to-noise ratio, and the additional noise reduction due to overlapping of the wave trains can be taken as a safety factor.

In carrier communication applications, the type of system used determines which noise characteristic is most important. In automatic simplex systems, operation of the transfer unit occurs when the peak value of the noise equals the r-f sensitivity setting of the unit. Although momentary operation of the transfer unit on extremely high isolated peaks occurring not oftener than once or twice a minute should not be objectionable, the signal-to-peak-noise ratio for noise peaks occurring more frequently should not exceed the 15 db shown in Table 7.

Quasi-peak noise levels are representative of the interfering effects of noise in duplex and manual simplex carrier communication channels. The figures of Table 7 can therefore be used as the maximum permissible signal-to-quasi-peak noise ratios in these systems for various grades of service.

Because it is not ordinarily possible to reduce appreciably the noise level present at a given receiving point in a carrier system, the only practical way to improve signal-to-noise ratio is to raise the signal level at the receiving point. It is not usually feasible to raise signal levels by increasing the transmitted power, because appreciable gains in terms of decibels require inordinately large increases in power. For example, to raise the signal level from a 10-watt transmitter by 20 db requires an increase to 1000 watts, or 100 times the original power. A much more practical solution is to reduce the channel attenuation by judicious application of line traps to eliminate short taps or spur lines and alternate paths.

REFERENCES

Carrier Equipment and Applications

1. "Modern Power-Line Carrier Equipment," E. L. Harder, *Westinghouse ENGINEER*, July 1944, pp 98-104.
2. "Power-Line Carrier Communication," R. C. Cheek, *Westinghouse ENGINEER*, September, 1947, pp 151-154.
3. "The Applications of Power-Line Carrier," R. C. Cheek, *Power Plant Engineering*, Nov. 1945, pp 76-81.
4. "A Versatile Power-Line Carrier System," H. W. Lensner and J. B. Singel, *AIEE Transactions*, Vol. 63, 1944.
5. "A Simple Single-Sideband Carrier System," R. C. Cheek, *Westinghouse ENGINEER*, November 1945, pp 179-183.
6. "A New Single-Sideband Carrier System for Power Lines," B. E. Lenehan, *AIEE Transactions*, Vol. 66, November 1947.
7. "The Combination of Supervisory Control with Other Functions on Power-Line Carrier Channels," R. C. Cheek, W. A. Derr, *AIEE Transactions*, Vol. 64, May, 1945, pp 241-246.
8. "Power-Line Carrier," F. S. Mabry, *Industrial Electronics Reference Book*, Chapter 25, pp 442-456, John Wiley & Sons, New York, 1948.

Modulation Systems

9. "Frequency Modulation for Power-Line Carrier Current," E. W. Kenefake, *AIEE Transactions*, Vol. 62, 1943, pp 616-620.
10. "A Comparison of the Amplitude Modulation, Frequency Modulation, and Single Sideband Systems for Power-Line Carrier Transmission," R. C. Cheek, *AIEE Transactions*, Vol. 64, May 1945, pp 215-220.
11. "Power-Line Carrier Modulation Systems," R. C. Cheek, *Westinghouse ENGINEER*, March 1945, pp 41-45.

Transmission Theory and Carrier Channel Application

12. *Communication Engineering* (book), W. L. Everitt, McGraw-Hill Book Co., New York, 1937.
13. *Electrical Transmission of Power and Signals* (book), Edward W. Kimbark, John Wiley & Sons, New York, 1949.
14. "Propagation d'ondes haute fréquence le long d'une ligne triphasée symétrique," A. Chevallier, *Rev. Gen de l'Electricité*, Vol. LIV, January 1945.
15. "Application of Carrier to Power Lines," F. M. Rives, *AIEE Transactions*, Vol. 62, 1943, pp 835-844.
16. "Power-Line Carrier Channels," M. J. Brown, *AIEE Transactions*, Vol. 64, May 1945, pp 246-250.
17. "Operation of Power-Line Carrier Channels," H. W. Lensner, *AIEE Transactions*, Vol. 66, November, 1947.

Noise and Noise Measurement

18. Survey of Existing Information and Data on Radio Noise Over the Frequency Range 1-30 Mc/s. H. A. Thomas, R. E. Burgess, Special Report No. 15, Radio Research, Department of Scientific and Industrial Research, National Physical Laboratory, London, 1947.
19. "Selective Circuits and Static Interference," *Bell System Technical Journal*, Vol. 4, 1925, pp 265-279.
20. "Frequency-Modulation Noise Characteristics," M. G. Crosby, *Proceedings IRE*, Vol. 25, 1937, pp 472-514.
21. "An Experimental Investigation of the Characteristics of Certain Types of Noise," K. G. Jansky, *Proceedings IRE*, Vol. 27, 1939, pp 763-768.
22. "A Study of the Characteristics of Noise," V. D. Landon, *Proceedings IRE*, Vol. 24, 1936, pp 1514-1521.
23. "Methods of Measuring Radio Noise," Joint Committee on Radio Reception of EEL, NEMA, and RMA, EEI Publication G9, NEMA Publication No. 107, February 1940.
24. "Proposed American Standard Specification for a Radio Noise Meter—0.15 to 25 Mc/s." ASA Sectional Committee on Radio-Electrical Coordination, ASA C 63.2—1949.

CHAPTER 13

POWER-SYSTEM STABILITY BASIC ELEMENTS OF THEORY AND APPLICATION

Original Authors:

R. D. Evans and H. N. Muller, Jr.*

Revised by:

J. E. Barkle, Jr. and R. L. Tremaine

THIS chapter presents a general introduction to the power-system stability problem including definitions of basic terms, useful physical and analytical concepts, methods of calculation of steady-state and transient stability problems for simplified systems, and the extensions necessary for the application of these principles to practical systems. Short-cut methods for estimating permissible transmission-line loading, and the transient stability performance of common systems are presented. Means of improving system stability are discussed. Examples of steady-state and transient stability calculations appear throughout the chapter.

On commercial power systems, the larger machines are of the synchronous type; these include substantially all of the generators and condensers, and a considerable part of the motors. On such systems it is necessary to maintain synchronism between the synchronous machines under steady-load conditions. Also, in the event of transient disturbances it is necessary to maintain synchronism, otherwise a standard of service satisfactory to the user will not be obtained. These transient disturbances can be produced by load changes, switching operations, and, particularly, faults and loss of excitation. Thus, maintenance of synchronism during steady-state conditions and regaining of synchronism or equilibrium after a disturbance are of prime importance to the electrical utilities. Electrical manufacturers are likewise concerned because stability considerations determine many special features of apparatus and under many conditions importantly affect their cost and performance. The characteristics of virtually every element of the system have an effect on stability. It introduces important problems in the coordination of electrical apparatus and lines in order to provide, at lowest cost, a system capable of carrying the desired loads and of maintaining a satisfactory standard of service, both for steady-state conditions and at times of disturbances.

The problem of system stability had its beginning when synchronous machines were first operated in parallel or in synchronism. It was early recognized that the amount of power that can be transferred from one synchronous machine to another is limited. This amount of load is known as the stability limit, and when it is exceeded, the machine acting as a generator "over speeds" and the machine acting as a motor "stalls."

As power systems developed, it was found with certain

*H. N. Muller, Jr. was the original author of "System Stability—Examples of Calculation," which has been included in Chapter 13 in this revision.

machines, particularly with certain systems connected through high-reactance tie lines, that it was difficult to maintain synchronism under normal conditions and that the systems had to be separated in the event of faults or loss of excitation. Various emergency conditions occasionally made it necessary to operate machines and lines at the highest practicable load; under these conditions stability limits were found by experience. Subsequently, it became apparent that many of the interruptions to service were the result of disturbances that caused loss of synchronism between various machines and that, by modifying the system design, layout, or operation, it was possible to provide a better standard of service.

The early analytical work on system stability was directed to the determination of the power limits of synchronous machines under two conditions: first, the pull-out of a synchronous motor or generator from an infinite bus; and second, the pull-out or stability limit for two identical machines, one acting as a generator and the other acting as a motor. However, the principal developments in system stability did not come about as an extension of synchronous-machine theory, but as the result of the study of long-distance transmission systems.

The modern view of the stability problem dates from the 1924 Winter Convention of the American Institute of Electrical Engineers when a group of papers† called attention to the importance of the problem and presented the results of the first laboratory tests¹ on miniature systems proportioned to simulate a power system having a long transmission line. Another important step was taken in 1925 when the first field tests^{4,5} on stability were made on the system of the Pacific Gas and Electric Company. Much additional practical information⁹ on the problem was obtained by transient recording apparatus, first installed on the system of the Southern California Edison Company. Initially the studies of the problem were restricted principally to the determination of whether certain layouts, proposed for the longer transmission projects, were actually capable of transmitting the desired amount of power under steady-state conditions. Subsequently, it was found that the more important phase of the problem was in the determination of system layouts and loads that would insure satisfactory operating characteristics at times of various transient disturbances arising from load changes, switching operations, and circuit faults with their subsequent isolation. During the ten-year period from 1924 to 1933, the theory of system stability was carefully investi-

†*AIEE Transactions*, vol. 43, pp. 16-103, 1924.

gated. During this work there were proposed many new methods of improving the stability of systems as discussed in the latter part of this chapter. Since that time considerable experience has been obtained with methods of analyzing stability and with new methods of improving stability, with the result that the subject is now considered to be on a basis that is satisfactory from the standpoint of theory and practice.

The notation used throughout this chapter is as follows: E represents a vector quantity and may be expressed in terms of rectangular coordinates or in polar form. \bar{E} represents the magnitude or scalar value of vector E . Thus,

$$E = \bar{E}(\cos \theta + j \sin \theta) = \bar{E}e^{j\theta} = \bar{E}/\theta$$

I. BASIC CONCEPTS OF STABILITY

1. Essential Factors in the Stability Problem

The essential factors in the stability problem are illustrated in connection with the two-machine system shown schematically in Fig. 1. The various elements of the sys-

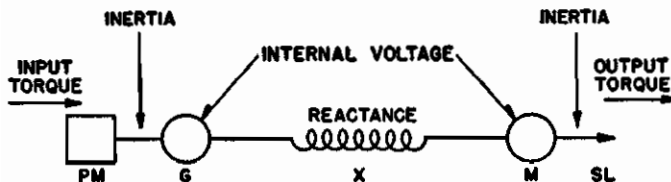

Fig. 1—Basic diagram for the two-machine stability problem.

- PM—Prime mover.
- G—Synchronous generator.
- X—Reactance line.
- M—Synchronous motor.
- SL—Shaft load.

tem, prime mover, synchronous generator, reactance line, synchronous motor, and the shaft load, are indicated. There are seven essential factors affecting stability. These are of two kinds, mechanical and electrical. The essential mechanical factors are:

1. Prime-mover input torque.
2. Inertia of prime mover and generator.
3. Inertia of motor and shaft load.
4. Shaft-load output torque.

The essential electrical factors are:

1. Internal voltage of synchronous generator.
2. Reactance of the system including:
 - a. Generator
 - b. Line
 - c. Motor.
3. Internal voltage of synchronous motor.

In the foregoing discussion, losses have been ignored and this is permissible since losses do not affect the phenomena except to introduce damping for which allowance can easily be made after the character of the system oscillations is understood. To introduce damping at the outset would obscure the character of the essential phenomena involved.

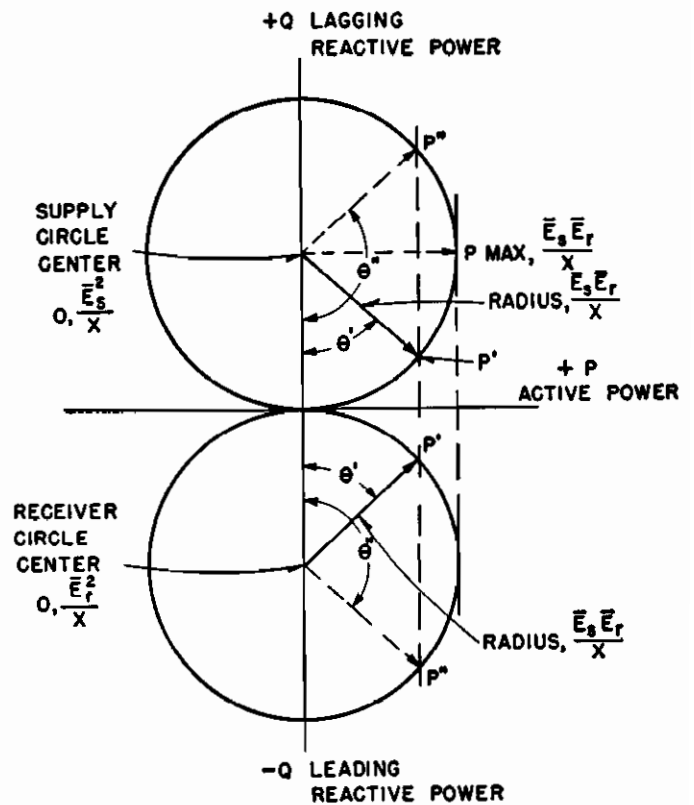

Fig. 2—Elementary power-circle diagram for line reactance X , voltages E_s and E_r , system of Fig. 1.

2. Power-Circle Diagrams and Power-Angle Diagrams

The performance characteristics of the simple two-machine power-transmission system, Fig. 1, are readily shown by power-circle diagrams and power-angle diagrams as given in Figs. 2 and 3 respectively. The diagrams are based on methods described in Chap. 9 and are reducible to the simple form shown because they depend, in the absence of loss, merely upon the four factors \bar{E}_s , \bar{E}_m , θ and X . The equation relating power transfer in a three-phase system is as follows:

$$P = \frac{\bar{E}_s \bar{E}_m}{X} \sin \theta \tag{1}$$

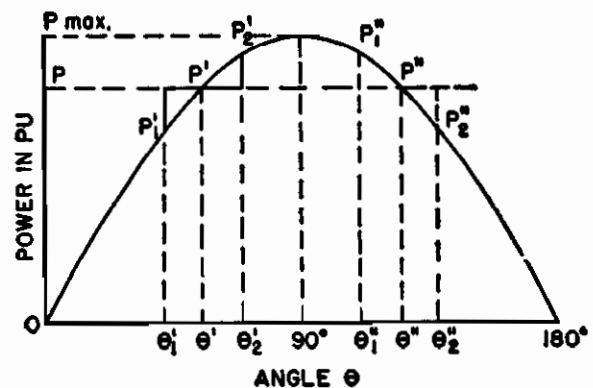

Fig. 3—Elementary power-angle diagram, system of Fig. 1.

where:

- P = three-phase power transferred in watts.
 \bar{E}_g = internal voltage of generator (line-to-line volts).
 \bar{E}_m = internal voltage of motor (line-to-line volts).
 X = reactance between generator and motor internal voltages, ohms per phase.
 θ = angle by which the internal voltage of generator leads the internal voltage of motor.

When per-unit values of voltages and reactance are used in Eq. (1), the power transferred is obtained as a per-unit quantity referring to the kva base being used. Thus, the three-phase power flow in kilowatts would be the per-unit value multiplied by the kva base.

3. Meaning of Stability Terms

The terms "stability" and "maintenance of synchronism" are quite frequently used interchangeably. However, a system consisting of a synchronous generator, a reactance line, and an induction motor may become unstable but cannot lose synchronism. Nevertheless, system stability is, ordinarily, of importance only when it deals with the conditions of stable operation between synchronous machines. The problem is of importance, primarily from the standpoint of the maximum amount of power that can be transmitted without instability being incurred under steady-state conditions or as a result of circuit changes or faults. The terms "stability" and "power limit" are also frequently used interchangeably. However, a simple system consisting of a generator, a reactance line, and a resistance load has a definite power limit without having a stability limit.

Stability can be formally defined as follows:

Stability when used with reference to a power system, is that attribute of the system, or part of the system, which enables it to develop restoring forces between the elements thereof, equal to or greater than the disturbing forces so as to restore a state of equilibrium between the elements.*

Stability applies to both steady-state and transient conditions on a power system. The distinction between them depends upon whether the stability applies to a condition that includes a transient disturbance. Certain automatic devices, such as voltage regulators, have a bearing on the stability conditions. If such devices are used this fact should be indicated as follows: steady-state stability with automatic devices.

Stability limit for a system with synchronous machines can be considered the same as the power limit, and is defined as:

A *Stability Limit* is the maximum power flow possible through some point in the system when the entire system or the part of the system to which the stability limit refers is operating with stability.*

Criterion of Stability—There are several criteria for the determination of the conditions establishing stability that are needed in connection with the analysis of complicated systems. These criteria can be stated as follows:

*American Standard Definitions of Electrical Terms, ASA-C42-1941.

A power-transmission system operating under specified circuit and transmitted load conditions is said to be stable if, when displaced from these conditions by any small arbitrary forces, the system upon removal of these forces develops restoring forces tending to return it to the original conditions.

The arbitrary displacement can be made in several ways, the most convenient of which is a small arbitrary increase in the angular displacement.

4. Application of the Criterion of Stability

The application of the definition of stability and the criterion of stability will now be considered in connection with the system of Fig. 1. Examination of Figs. 2 and 3 shows that solutions are obtained for the points corresponding to the power P' at the angle θ' and also to the power P'' at the angle θ'' . In the absence of loss, the amounts of sending and receiving power are equal and P' and P'' are equal.

In applying the criterion of stability, the system is assumed to be subjected to a slight arbitrary reduction in angle between internal voltages from θ' to θ_1' in Fig. 3, and the power transferred from the generator to the motor is correspondingly reduced from P' to P_1' . The input and output torques, Fig. 1, remain constant and are equal to each other and to P in Fig. 3 since the system is assumed to have no loss. The prime-mover input power P is now greater than the electrical output power P_1' , resulting in acceleration of the generator rotor which tends to increase the angle between the sending and receiving ends of the system. At the receiving end, the electrical input to the motor P_1' is now less than its mechanical output P and this difference in power decelerates the motor, which also tends to increase the angle between the sending and receiving ends. Thus the arbitrary reduction of the angle between the internal voltages of the generator and motor from θ' to θ_1' reduced the electrical power transferred through the system and resulted in the development of restoring forces tending to increase the angle between the internal voltages and return the system to the original angle θ' . Since losses have been omitted, the angle between the internal voltages would oscillate about the value θ' , but in a practical system where losses are always present, this oscillation would be damped and the system would eventually return to the original angle.

Next, assume that the system is subjected to a slight arbitrary movement increasing the angle from θ' to θ_2' . Under this condition the output of the generator P_2' is greater than its input, which corresponds to P . The difference in input and output decelerates the generator and thus tends to reduce the angle between the sending and receiving ends. Similarly, since losses are neglected, the input to the motor is greater than its shaft load with the result that the motor accelerates and thus tends also to reduce the angle between the sending and receiving ends. The arbitrary displacement of the system, by a small amount from the solution at the angle θ' in such a direction as to increase the angle, creates restoring forces to return the system to the original operating point.

It has been shown that if the system operating at the angle θ' is subjected to small disturbing forces, then regardless of the direction of the small disturbing forces, when

these forces are removed the system develops restoring forces in such a direction as to return the system to the original angle between the internal voltages of the generator and motor. Therefore, the mathematical solution corresponding to the power P' and the angle θ' constitutes a stable operating point, since any tendency for the system to drift away from the operating point θ' develops adequate restoring forces.

Critical Point in System Oscillation—Consider next the operation at the point defined by the angle θ'' and the power P'' . Assume the condition with the angle θ'' increased to θ_2'' . Under this condition the output of the generator and input of the motor are decreased to P_2'' , so that the output of the generator is less than its input, and the input of the motor is less than its output or shaft load. These circumstances produce forces that accelerate the generator and decelerate the motor, and increase further the angle by which the generator leads the motor. The changes in force are such as to augment the change in angle with the result that the system pulls out of step, that is, the system becomes unstable. Apply next this same criterion for the condition of a slight reduction in the angle below θ'' . For θ_1'' the electrical output of the generator is greater than its mechanical input and the electrical input to the motor is greater than its mechanical output or shaft load. The change in the angle between internal voltages in the system slows down the generator and speeds up the motor. Both of these changes cause the system to reduce still further the angle between the internal voltages. Thus the solution corresponding to the angle θ'' and the power P'' is said to be an unstable solution since a slight departure from that point sets up forces to augment the change in that same direction instead of restoring the condition to the original point of solution. However, in the case of movement back from the point corresponding to the angle θ'' , the system further reduces the angle and moves in the direction of the stable operating point at θ' . The system will develop forces causing it to move in the direction of θ' for all angles between θ'' and θ' .

Thus the point corresponding to the angle θ'' is the *critical point in system oscillation* for given internal voltages, reactance, and power-flow conditions. If the system has a stable solution at θ' , it can withstand system disturbance that causes it to oscillate on either side of this angle up to θ'' . If that angle is exceeded, the system will lose synchronism. If that angle is not reached, the system will oscillate about θ' and because of losses it will come into equilibrium at that angle.

5. Steady-State Stability Limit

For the simple two-machine transmission system illustrated in Fig. 1, the steady-state stability limit is given by the maximum power obtained from either the power-circle diagram or the power-angle diagram of Figs. 2 and 3. The steady-state stability limit of a system without loss occurs at the angle of 90 degrees between sending and receiving ends as shown by these diagrams or as readily obtained from Eq. (1). The steady-state limit for a three-phase system is given by

$$P_{\max} = \frac{\bar{E}_s \bar{E}_m}{X} \quad (2)$$

which gives the maximum power in watts when the voltages are expressed as line-to-line volts and the reactance as ohms per phase, or the maximum power in per unit when per-unit voltage and reactance are used. If the criterion of stability is applied, (1) for all load conditions with the power and angle less than those corresponding to the 90-degree limit, the system will be inherently stable; whereas (2) for all loads at angles greater than 90 degrees the system will be unstable. The 90-degree load point for a system without loss is the *critical load* or the maximum value of all steady-state operating points that are inherently stable.

There is a single steady-state stability limit for specified circuit, impedance, and internal voltage conditions. It follows, therefore, that if the excitation of either or both machines is changed so as not to correspond to the internal voltages assumed, the stability limit will be correspondingly changed. Loss of field results, of course, in reducing the synchronizing power to zero. The machine that loses its excitation pulls out of synchronism with the other synchronous machines and operates as an induction machine. Whether the system is stable or unstable as a combination of synchronous and induction machines is determined in part by the characteristics of the induction machines.

6. Transient-Stability Limit

Transient stability refers to the amount of power that can be transmitted with stability when the system is subjected to an "aperiodic disturbance." By *aperiodic disturbance* is meant one that does not come with regularity and only after intervals such that the system reaches a condition of equilibrium between disturbances. The three principal types of transient disturbances that receive consideration in stability studies, in order of increasing importance, are:

1. Load increases.
2. Switching operations.
3. Faults with subsequent circuit isolation.

The basic power-angle diagrams give an adequate picture of the stability phenomena encountered in each of these disturbances.

Load Increases can result in transient disturbances that are important from the stability standpoint if (1) the total load exceeds the steady-state stability limit for spe-

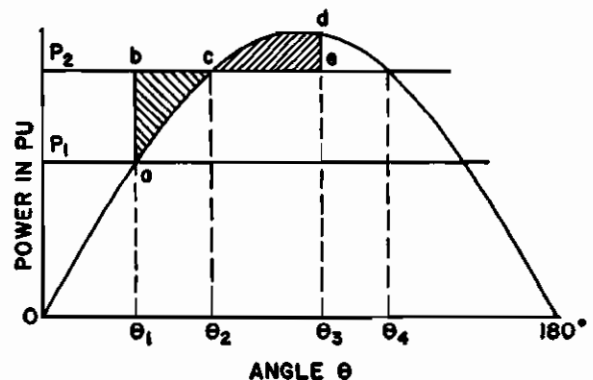

Fig. 4—Power-angle diagram for analyzing load increases.

cific voltage and circuit reactance conditions, or (2) if the load increase sets up an oscillation that causes the system to swing beyond the *critical point* from which recovery would be impossible, as pointed out previously. Consider a system operating under the conditions shown in Fig. 4 with the load P_1 at the angle θ_1 and the prime-mover input and shaft output abruptly increased to P_2 . Because of the inertia of the rotating machines, the internal voltages of the generator and motor do not immediately swing to θ_2 , which would permit transfer of power P_2 . Instead, the initial differences of power input and output are used in accelerating the generator and in decelerating the motor rotating elements. Both of these changes cause the rotors to depart from synchronous speed and to increase their angular differences. Thus when the system reaches θ_2 , the generator is traveling above synchronous speed and the motor below synchronous speed. The difference in the stored energy cannot instantly be absorbed and as a result the system overshoots θ_2 and reaches some larger angle as θ_3 , such that the shaded area cde is equal to the area abc . Neglecting losses, these two areas can be taken as equal³. The oscillation will not exceed the angle θ_3 , and because of losses in an actual system, equilibrium will ultimately be reached at θ_2 . In the case illustrated in Fig. 4 the system oscillates to the angle θ_3 , which is greater than 90 degrees but is stable because θ_3 is less than θ_4 , the critical angle for the load P_2 . With a somewhat larger total load or with a greater increment of load, the maximum point reached in the oscillation would be greater than θ_3 shown in the diagram. With increasingly severe conditions, a point is reached where the critical angle is equaled and this represents the transient limit for the load increase. The amount of load increase that a system can withstand depends upon the steady-state limit of the system and the initial operating angle. Figure 5 shows the total permissible sudden increase in amount of power that can be absorbed with stability, expressed as a percentage of the steady-state stability limit of a system without loss and plotted as a function of the angle between internal voltages.

Switching Operations—The transient-stability limits

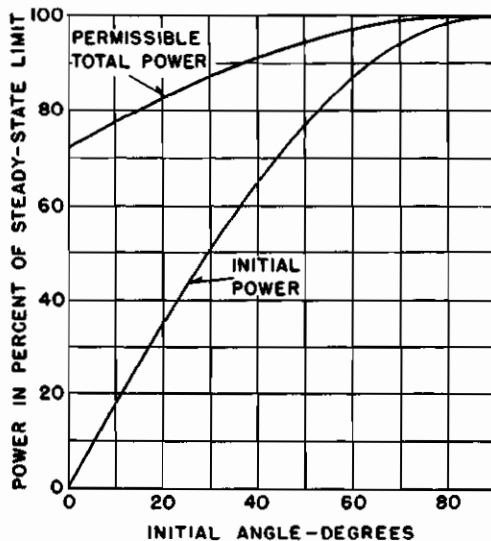
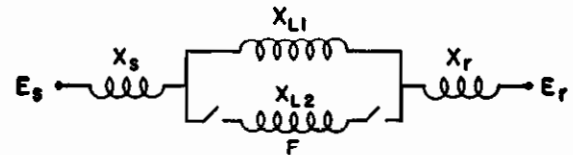
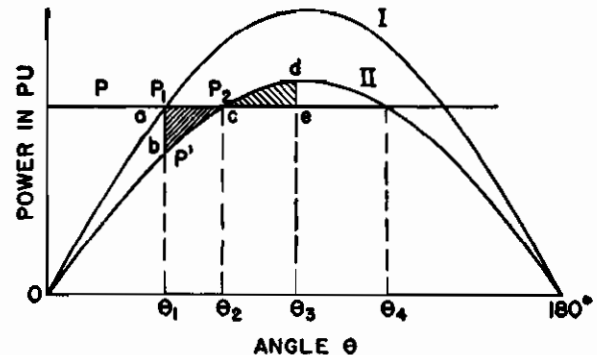

Fig. 5—Permissible load increase vs. initial-angle curve.

for switching operations can be investigated in a similar manner using the equal-area criteria³ that have been applied for the determination of the transient limit for load increases. In the case of switching operations there are, however, two power-angle diagrams that require consideration: (1) the power-angle diagram for the initial condition, (2) the power-angle diagram for the final condition, that is, the condition after the switching operation has taken place. Figure 6 (a) indicates a system with two lines initially in service; Fig. 6 (b) shows two power-angle diagrams, Curve I applying to the initial circuit-condition and Curve II applying to final circuit-condition. The diagram shows the transmitted power P , the initial operating condition at the angle θ_1 and the power P_1 , and the final operating condition at θ_2 and P_2 . The moment the switching operation takes place the electrical output is reduced from P_1 to P' . This change produces an increment of magnitude $(P - P')$, which is available for accelerating the generator and decelerating the motor, both changes tending to increase the angle between the sending and receiving machines. Thus, the two machines depart



(a) EQUIVALENT CIRCUIT



(b) POWER-ANGLE DIAGRAM

Fig. 6—Power-angle diagram for analyzing transients due to switching operations.

from synchronous speed, accelerating and decelerating forces increasing the angle from θ_1 to θ_2 . At this point the generator rotor is traveling above synchronous speed and the motor rotor below synchronous speed with the result that both rotors tend to overshoot θ_2 and to reach θ_3 , such that the area abc is equal to the area cde . At θ_3 , the energy stored above and below synchronous speed has been absorbed and since the instantaneous power output of the generator and input of the motor are greater than the prime-mover input and shaft loads, respectively, restoring forces are developed that cause the system to oscillate about θ_2 and reach a condition of equilibrium because of losses in a practical system.

The amount of power transferable without loss of synchronism depends upon (1) the steady-state stability limit

for the condition after the switching operation takes place and upon (2) the difference between initial and final steady-state operating angles. The stability limits for switching operations are lower for the larger amount of the final circuit reactance and for the greater percentage change in the circuit reactance.

Faults and Subsequent Circuit Isolations—The third and most important type of transient disturbance arises from application of faults and the subsequent circuit changes required to isolate the fault. For such disturbances three or more circuit conditions require consideration: (1) the initial condition, immediately prior to the fault, (2) the condition during the fault, and (3) the condition subsequent to the isolation of the fault. Additional conditions are required to cover the cases in which the fault is isolated in two or more steps, such as would be produced by the disconnection of a line section by sequential switching. Additional steps would be required to take care of the case of a high-speed reclosing breaker, which first disconnects a faulted line and suppresses the arc, and subsequently restores the line to the original circuit connection. However, the procedure to be followed in the more complicated cases will become evident from consideration of the simpler case.

Consider a transmission system similar to Fig. 6 (a) but with one line subjected to a fault at an intermediate point. The power-angle diagram for the case with the two lines in service is indicated in Fig. 7 by the Curve I, which

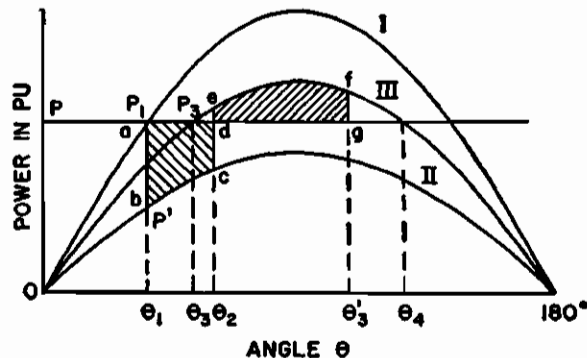

Fig. 7—Power-angle diagram for analyzing transient disturbances due to faults with subsequent circuit isolation. See Fig. 6 (a).

intercepts the line of transmitted power at the angle θ_1 and the power P_1 . Upon application of the fault the amount of power transferable from one end to the other is reduced. If the fault were a zero-impedance fault on all lines the power transmitted would be reduced to zero. However, if, as is usually the case, the fault is not a zero-impedance fault on all lines, some power can be transmitted from the sending to the receiving ends. This case is assumed in the diagram of Fig. 7 and is indicated by the Curve II passing through the points b and c . The power-angle diagram for the final condition with the faulted line switched out of service is shown by the Curve III that passes through the line of transmitted power at the angle θ_3 and the power P_3 . Upon application of the fault, the power output of the generator and the power input to the motor are reduced

from P to P' , the difference in power ($P - P'$) being absorbed in accelerating the generator and decelerating the motor. For the severe type of fault shown, the system would pull out of step if the fault were not promptly cleared. Assume, however, that the fault is cleared by the time the system swings to θ_2 . At this point, transfer is made to the final circuit condition, Curve III. The power-angle diagram shows that the power output of the generator exceeds the input, with the result that the generator rotor is decelerated and that the motor is accelerated. However, because of the energy stored in the machine rotors above and below synchronous speed the system continues to swing to some larger angle, such as θ_3' , so that the area $defg$ is equal to the area $abcd$. Thus, θ_3' is the maximum point reached in the system oscillation using the same equal-area criteria discussed in connection with other types of transient disturbances. The system oscillates about the angle θ_3 and because of losses will ultimately come to equilibrium at that angle.

If the severity of the fault is increased, as indicated by the reduction in amount of power that can be transmitted during the fault condition, or if the duration of the fault is increased as indicated by a larger θ_2 , or if the power-angle diagram for the final condition has a lower maximum, the largest angle during the system oscillation is increased beyond θ_3' and under some conditions would reach the critical angle θ_4 for the transmitted power under the final circuit condition. When this condition is met the transient-stability limit for the condition is said to be reached.

The nature of transient disturbances incident to faults can be examined further in connection with the use of quick-reclosing breakers as illustrated in Fig. 8. Two cases are considered, namely, a single-circuit case shown in (a) and a double-circuit case shown in (b). In both cases, the faulted line is de-energized to suppress the arc in the fault and reclosed after an interval for the purpose of insuring stability. These switching operations provide a succession of power-circuit conditions and a corresponding set of power-angle diagrams as can be seen by a detailed examination of Fig. 8. The conditions necessary for maintaining stability are also stated in terms of the stored-energy relations as shown by corresponding areas on the power-angle diagram.

No method has been given for the determination of the angles, θ_2 in Fig. 7, or θ_2 and θ_3 in Figs. 8 (a) and (b), which define the condition for which the fault is removed or the circuit switched. From a practical standpoint the circuit change is not made in accordance with the angular difference between the sending and receiving ends; instead it is made as a function of time measured from fault application, the duration being that required for the operation of protective relays and circuit breakers. This time can be calculated by a step-by-step process to determine the changes in accelerating force, the changes in velocity, and the changes in angles. Thus, the determination of the angle-time relations constitutes one of the important steps in transient-stability calculations and will receive considerable attention in subsequent sections.

For a power system with machines of assumed constant internal voltages, with circuits of assumed reactances, and with losses neglected, there is only one steady-state limit.

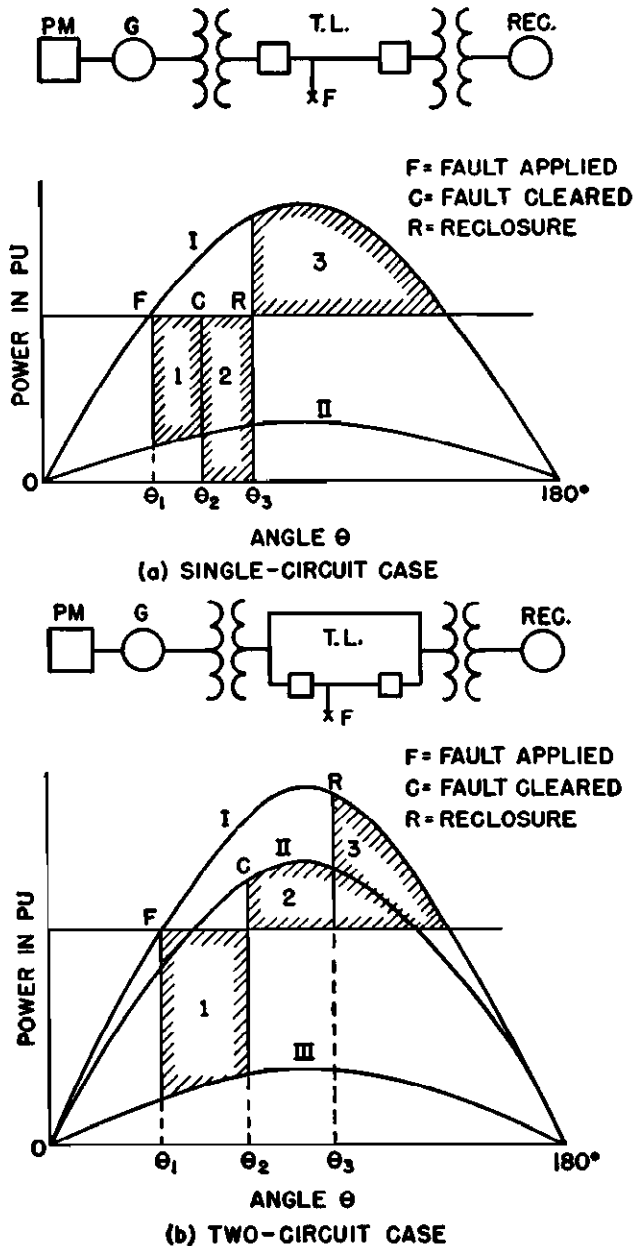

Fig. 8—Power-angle diagram for reclosure.

- (a)—Single-circuit case
 Curve I for normal circuit
 Curve II for fault condition ($2L-G$)
 For stability, areas (1 plus 2) \leq area 3
- (b)—Two-circuit case
 Curve I for two lines (normal)
 Curve II for one line (normal)
 Curve III for fault ($2L-G$)
 For stability, area 1 \leq areas (2 plus 3)

However, for the transient-stability calculations there are many conditions depending upon the character of the transient under consideration. For example, for load increases, the transient-stability limit depends upon the initial load and the increment of load. For the switching operation, the transient limit depends upon the stability limit for the final circuit condition and upon the initial

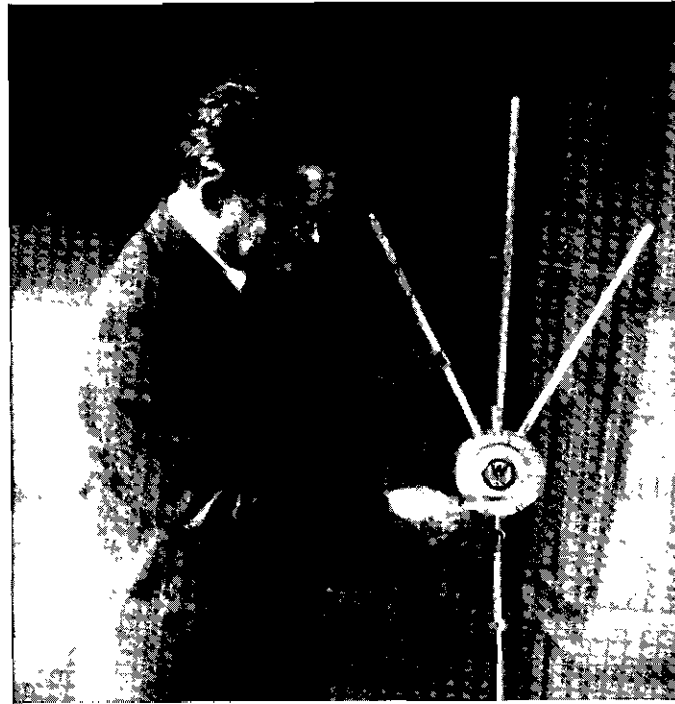

Fig. 9—The mechanical model (set up for a system with two generators and an intermediate synchronous condenser).

operating angle. The transient limit for the simplest condition involving a fault on a system with subsequent circuit isolation depends upon the initial operating angle, the severity of the fault and its duration, and the stability limit for the system after the fault is cleared. It becomes necessary, therefore, when giving a transient-stability limit of a system to define the conditions under which the limit applies.

7. The Mechanical Analogy of a Power-Transmission System

The definitions of stability given in Sec. 3 and the subsequent discussions have been given in terms of equilibrium of the power-transmission system. Equilibrium phenomena are ordinarily visualized in terms of a static system in mechanics. However, the discussion of the familiar static systems cannot directly be applied to the complicated electro-mechanical system employed in power transmission. Furthermore, the actual system involves dynamic rather than static equilibrium. To circumvent this difficulty a mechanical analogy, which has properties corresponding to the actual dynamic electro-mechanical system, has been devised.

The most convenient means of visualizing the basic phenomena of a power-transmission system is the mechanical analogy developed by S. B. Griscom⁶ and shown in Figs. 9 and 10. The mechanical analogy or mechanical model, as the device is more commonly called, consists essentially of two rotatable units mounted on a common shaft and provided with lever arms, which are connected at their outer ends by a spring. One of these rotatable elements is designated as the generator element and the other as the motor element. Each of these elements is provided with means for applying torque in such a way as to stretch the spring connecting the lever arms.

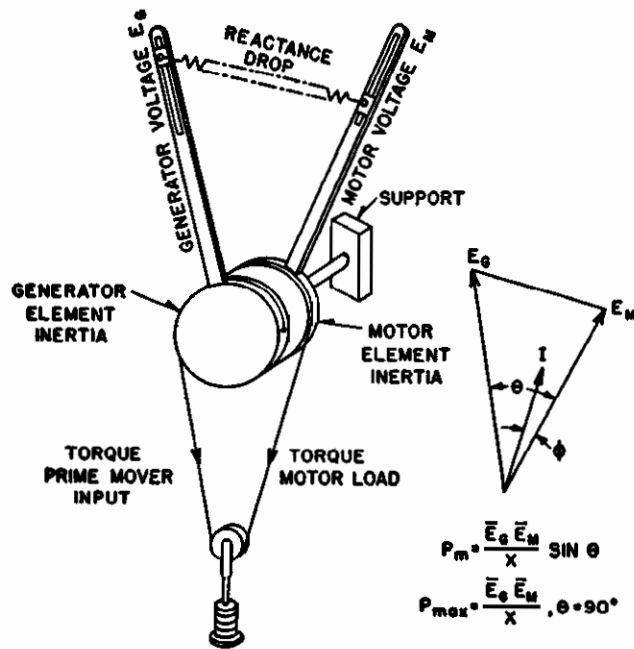

Fig. 10—The mechanical analogy for power-system stability.

Mechanical Model	Power-Transmission System
1. Radial distance from pivot to any point on spring.	Line voltage at corresponding point.
2. Length of spring.	Line reactance drop.
3. Tension of spring, proportional to its length.	Line current.
4. Torque of either arm = product of the length of the arm and component of spring tension perpendicular to arm.	Active power.
5. Product of the length of the arm and component of spring tension along the radius at any point.	Reactive power.
6. Angle between any two points on the spring.	Phase displacement of voltages at the corresponding points of the system.

The correspondence between the various mechanical and electrical factors of the mechanical model and the power-transmission system is shown in connection with Fig. 10. The mechanical model is stationary for the normal synchronous frequency, and the power-flow relations are represented by torques. Movement of the model corresponds to oscillations of the power system with respect to normal synchronous speed. Thus, the model shows only the changes in movement that are significant from the standpoint of stability. The mechanical model has a power limit occurring at an angle of 90 degrees between the lever arms of a two-machine system. The model is also proportioned so as to simulate transient conditions as well as steady-load conditions. The mechanical model can be extended by the addition of rotatable elements and additional springs so as to simulate complicated power systems. For example, a transmission system with an intermediate synchronous condenser can be represented by the aid of the third element of Fig. 9 with the addition of a spring from the lever arm of the third element to the appropriate point on

the spring connection between the other two rotatable elements.

The mechanical model has been used for the calculation of actual stability problems but the a-c network calculator method is more convenient. Thus, the mechanical model is now employed in its original function of providing the best qualitative method of visualizing the essential phenomena in the power-system stability problem. Sufficient information has been given to enable one mentally to set up the mechanical model for the corresponding system condition and to study its performance for various steady-state and transient conditions. While an actual model is of considerable assistance, the mechanical analogy is useful even though no model is available. It is suggested that the mechanical analogy should be considered in connection with the entire discussion of this chapter, particularly in connection with multi-machine problems, such as those involving an intermediate synchronous condenser, since it frequently happens that some particular point is more readily grasped from the consideration of the model than of the actual system.

II. REPRESENTATION OF SYSTEM FOR STABILITY CALCULATIONS

In discussing methods for calculating stability, it is convenient to consider first the case involving two synchronous machines, and, subsequently, those involving three or more machines. In the previous part the stability phenomena were discussed in terms of the two-machine system reduced to its elements with the electrical system represented by two internal voltages and one reactance between them. In practical systems, even for the two-machine case, it is necessary to consider other factors, such as:

1. Representation of system-impedance elements.
 - a. Series branches with resistance.
 - b. Shunt branches.
 1. Shunt capacitance.
 2. Shunt loads.
 3. Faults.
2. Initial operating conditions.
3. Representation of machines including the effects of regulators and exciters.

8. Representation of System-Impedance Elements

A typical layout for a two-machine transmission system is shown in Fig. 11. This system is assumed to have series resistances, shunt capacitances, shunt loads, maintained voltages at sending and receiving buses, and to be subjected to an unbalanced fault at point *F* on line 2, which is subsequently disconnected to isolate the fault.

In a practical system it is frequently necessary to consider the effect of resistance and of shunt capacitance, since these are always present in transmission lines. Since voltage is normally maintained on the sending and receiving buses, it is convenient to obtain the equivalent constants for the intervening part of the system. This can be done by the use of the generalized equivalent π network or the general circuit constants for the transmission line as described in Chaps. 9 and 10. In either case, it is possible

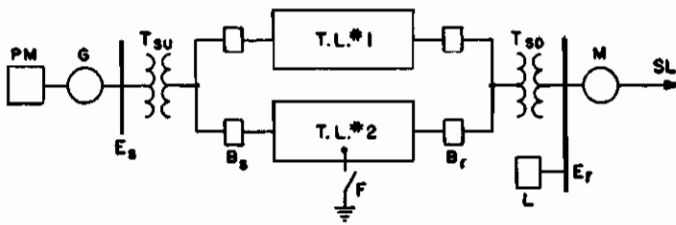

Fig. 11—Typical two-machine stability problem.

Notation: See Fig. 1; also the following:
 T_{su} —Step-up transformer.
 T_{sd} —Step-down transformer.
 $T.L.\#1, T.L.\#2$ —Transmission lines.
 B_s, B_r —Breakers.
 F —Fault.
 E_s, E_r —Voltages at regulated buses.
 L —Shunt load.

to derive power-circle diagrams and power-angle diagrams on the basis of the network intervening between buses, which have maintained voltages E_s and E_r . When loss is taken into account there is a difference between the sending and receiving power, as can be seen from Fig. 14. For this reason, power-angle relations for the two ends are no longer identical as assumed in Sec. 3. The method of taking this fact into account will be discussed subsequently in Sec. 23, Step-by-Step Procedure.

When loss or intermediate loads are present in a power transmission system, the maximum amounts of power at the sending and receiving ends occur at different angular displacements. If under steady-state conditions the prime-mover input corresponds to maximum input to the motor, two interesting phenomena occur if the shaft load is slightly increased. The motor slows down in any event, but the generator (1) may pull out of step with the motor and overspeed or (2) may stay in synchronism with the motor and slow down with it, depending upon the relative inertias of generator and motor. These phenomena, while of considerable theoretical interest*, are of little practical interest, except as indicative of margins, because the important load condition corresponds to the maximum delivered power and that is not dependent upon the relative inertia characteristics.

9. Representation of Shunt Loads

On a system that contains only two large synchronous machines requiring individual consideration, the various other loads may have different characteristics from the standpoint of changes in real and reactive components with change in voltage. It is usually permissible to assume for small synchronous motors and induction motors that the kilowatt load is independent of the voltage. Synchronous-converter load is assumed to vary in proportion to the square of the voltage. Lighting load is often assumed to vary as the square of the voltage, but it is more accurate to assume that the change is according to the 1.8 power of the voltage ratio³². The changes in reactive kva with voltage are widely different for these different typical loads, as shown in Fig. 12.

From a practical standpoint, it is not feasible to consider

*For further study of these phenomena see Reference 10 or 36.

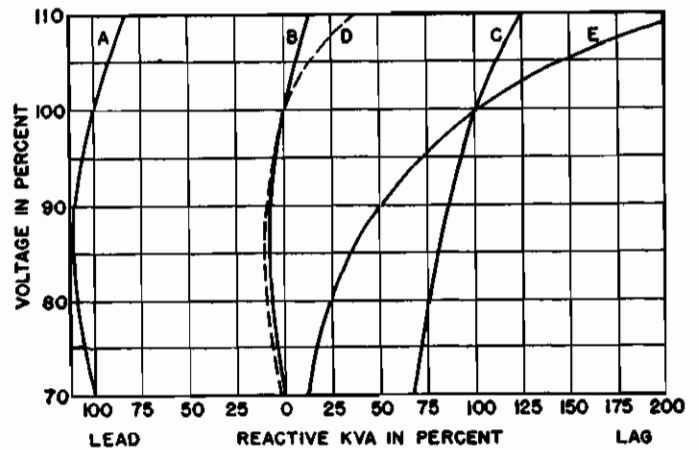

Fig. 12—Reactive Kva-Voltage characteristics of typical loads.

Curve	Description	Reactive Kva Base
A	100-kva synchronous motor 80 percent power-factor	60 kva
B	100-kva synchronous motor 100 percent power-factor	100 kva
C	15-hp induction motor, 80 percent load, 90 percent power-factor	5 kva
D	1000-kw synchronous converter	1000 kva
E	Transformer magnetizing kva	Value at 100 per- cent voltage

a large number of small shunt loads; instead, it is permissible to use a single composite load curve. To determine such a load characteristic an effort should be made to obtain the segregation of the principal types of load carried by the system under the conditions for which the stability characteristics are to be investigated. Table 1 gives a typical segregation of peak loads.

TABLE 1—SEGREGATION OF TYPICAL SHUNT LOADS

Induction Motor.....	60%
Synchronous Motor.....	10%
100% Power-Factor.....	5%
80% Power-Factor.....	5%
Synchronous Converter.....	5%
Lighting and Heating.....	25%

By combining the real and reactive components of loads from segregations similar to that of Table 1 and with reactive kva variations similar to those of Fig. 12, it is possible to arrive at a composite load characteristic curve, such as shown in Fig. 13, which includes 15 percent exciting kva. This figure shows the variations in both the real and reactive components of load with change in voltage using the real component at normal voltage as reference. The dotted curve of Fig. 13 shows the variation for a constant shunt-impedance load. Figure 13 also shows points on the power-voltage and reactive kva-voltage curves for 100 percent and 90 percent voltage obtained from tests on the Brooklyn Edison Company's system†. These tests showed for a 10 percent reduction in voltage that the power was reduced to 87 percent and the reactive kva to 80.6 percent of the corresponding values at normal voltage. These are

†System Load Swings, by Bauman, Manz, McCormack, and Seeley, *AIEE Transactions*, Vol. 60, 1941, p. 541, Disc., p. 735.

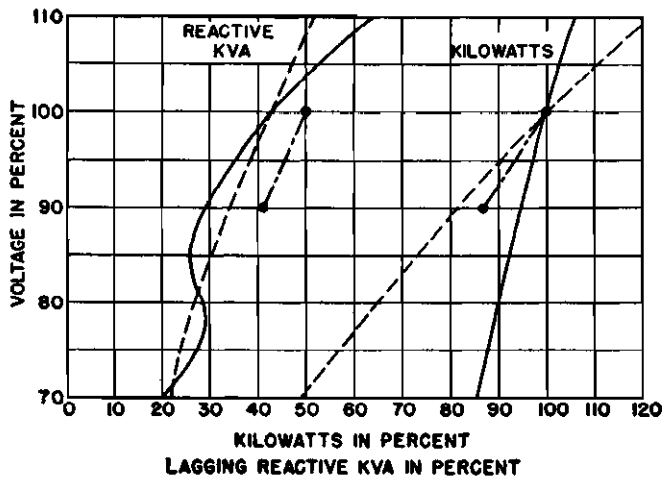

Fig. 13—Variation of composite load with voltage.

- Composite load based on Fig. 12.
- - - Constant impedance.
- · - (Bauman, Manz, McCormack and Seeley.) Normal kilowatts equal 100 percent.

to be compared with 81 percent, which would be obtained with a constant-impedance load of the corresponding power factor. The variations in load voltages usually are not great because they are maintained by local generators and synchronous condensers equipped with voltage regulators. This fact permits the relatively crude approximation of constant-impedance loads to give satisfactory results for the majority of cases.

10. Representation of Faults

In this discussion of stability, symmetrical systems only have received consideration. However, the majority of faults on power systems are not balanced three phase. As a consequence, the individual phase voltages are considerably unbalanced, and the voltage of neither the faulted nor unfaulted phase (or phases) is a measure of the voltage available for through power transmission. Instead, the positive-sequence voltage is the representative quantity.

In Fig. 21 of Chap. 2, interconnections between the sequence networks are given for various types of faults at a single location. When the sequence networks, as viewed from the point of fault, are thus interconnected to represent a particular type of fault, correct positive-sequence voltages and currents will exist at all points in the positive-sequence network (the original balanced network). Since only the positive-sequence quantities are to be used, all of the interconnected network except the positive-sequence network can be reduced to a single impedance*, which simplifies calculations. This impedance is, as the above discussion shows, a function of the negative- and zero-sequence impedances as measured from the point of fault, and varies with the type of fault. Thus, for a single line-to-ground fault this impedance is $(Z_2 + Z_0)$ connected from the point of fault to the neutral of the system; and for a double line-to-ground fault, it is $\left(\frac{Z_2 Z_0}{Z_2 + Z_0}\right)$, that is, Z_2 and

Z_0 in parallel, connected from the point of fault to the neutral. Thus the stability problem involving an unbalanced fault at a single location is reduced to one involving an equivalent three-phase symmetrical system. The original balanced network gives the desired positive-sequence quantities at all points when this equivalent impedance is connected to it†.

The physical interpretation of this method of handling unbalanced faults is helpful‡. The power and reactive kva consumed in the negative- and zero-sequence networks are generated in the machines as positive-sequence quantities and are transmitted through the system to the fault location. There these quantities are converted by the asymmetry of the fault to negative- and zero-sequence quantities which are fed back into the system and consumed as RI^2 and XI^2 for negative- and zero-sequence except for the effect produced by negative-sequence torques in machines. As pointed out in Chap. 6, the negative-sequence input to the rotor of a machine is consumed half in $R_2 I_2^2$ losses and half in negative-sequence torques. These torques tend to drive the machine in a direction opposite to that of its normal rotation. The accurate method of considering this effect is, of course, to modify appropriately the mechanical input to the machine. The negative-sequence resistance for typical machines is given in Table 4 of Chap. 6.

11. Determination of Initial Operating Conditions

Frequently in stability studies only part of the initial operating conditions are defined or are known. Consequently, to determine the initial conditions, calculations and frequently additional assumptions are necessary. Usually the delivered power and maintained voltages at sending and receiving buses are known. In addition, the characteristics of the transmission line, step-up and step-down transformers are known, although sometimes the kva capacity of the latter must be adjusted. For the determination of the initial operating conditions the use of the power-circle diagram is frequently advantageous because the bus voltages are usually known or can be assumed since they are subjected to relatively narrow variations. A particular method of using the power-circle diagram to assist in the determination of the initial operating conditions will now be described in connection with the system outlined in Fig. 11. The operating conditions of that part of the transmission system, including step-up and step-down transformers, between the sending and receiving buses whose voltages E_s and E_r are maintained, can conveniently be shown by the power-circle diagram of Fig. 14. The center of the receiving circle for the transmission line with transformers is plotted at the point C_r and of the sending-end circle at the point C_s . The positions of the

†This method is actually applicable to all types of unbalances, including open conductors and multiple faults at separate locations. For example, for the case of two conductors open, the equivalent impedance is the sum of the negative- and zero-sequence impedances as viewed from across the open, connected across the open of the positive-sequence network, i.e., an impedance between two points of the positive-sequence network. Referring to Chap. 2, Fig. 21 (p), impedances $(X_2 \text{ to } Y_2)$ plus $(X_0 \text{ to } Y_0)$ connected from X_1 to Y_1 .

‡Page 324 of Reference 27.

*Appendix III of Reference 5 and Reference 27.

method of calculation being used. This is discussed in detail in Sec. 14 where methods of steady-state stability calculation are described.

In transient-stability studies, the internal voltage is the vector sum of the terminal voltage and the transient-reactance voltage drop due to the load currents just prior to the disturbance.

III. STEADY-STATE STABILITY CALCULATIONS

In this part the general problem of steady-state stability calculation is discussed in detail and specific examples given to illustrate each method of calculation. Particular attention is given the problem of calculating the power limit of the synchronous generator connected to a system. The power limit in this case is commonly called the "pull-out power" or the "pull-out torque."

The pull-out power as discussed herein refers to a steady-state stability condition, which is initially of a transient character but must be endured long enough to bring it into the classification of steady-state stability. Tripping of a loaded generator, loss or reduction of the excitation of a generator, or the tripping of a tie line supplying power to the system illustrate that pull-out power or maximum power output of the generators involved is important. The pull-out power of a generator is calculated from the inherent characteristics of the generator, which are governed by such factors as air-gap length, demagnetizing effect of the stator on the rotor, degree of saturation, reactance, and short-circuit ratio. For modern machines if the short-circuit ratio is specified, the other factors usually have a fairly definite range of values, so that short-circuit ratio is the best single index of inherent steady-state stability of a generator.

The power equations in the following sections are written in terms of single-phase quantities. Thus, when the voltages are written as line-to-neutral volts and the reactances as ohms per phase, the power obtained from the equations is single-phase power. It should, of course, be multiplied by three to obtain the three-phase power. If all line-to-neutral voltages are multiplied by $\sqrt{3}$ and expressed as line-to-line volts, the equations give three-phase power directly. The equations can be used without alteration when the work is done using per-unit values.

13. Effect of Saliency on Steady-State Stability

The steady-state performance of a system containing unsaturated salient-pole machines can be calculated by the two-reaction method discussed in Chap. 6, particularly in connection with Figs. 12, 14, and 15. These diagrams are similar to that of Fig. 15 of this chapter, except that the notation has been changed from machine form to circuit form. For this diagram the relations of voltage and current in terms of the machine angles were previously derived or may be written by inspection as follows:

$$\bar{E}_d = \bar{E}_t \cos \theta + x_d \bar{I} \sin (\theta + \phi) \quad (5)$$

$$0 = -\bar{E}_t \sin \theta + x_q \bar{I} \cos (\theta + \phi) \quad (6)$$

$$\bar{I} = \frac{\bar{E}_d - \bar{E}_t \cos \theta}{x_d \sin (\theta + \phi)} \quad (7)$$

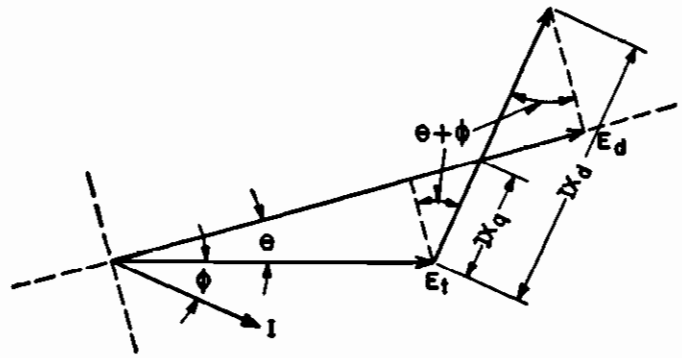

Fig. 15—Vector diagram for salient-pole synchronous machine based on two-reaction method.

\bar{E}_t —Terminal voltage (phase-to-neutral—rms).
 \bar{E}_d —Excitation voltage due to flux in direct axis.
 I —Armature current (line-rms).
 θ —Displacement angle.
 ϕ —Power-factor angle.

$$\bar{I} = \frac{\bar{E}_t \sin \theta}{x_q \cos (\theta + \phi)} \quad (8)$$

where x_d and x_q are direct- and quadrature-axis synchronous reactances. Equation (5) is based on the relations in the quadrature axis for which excitation voltage \bar{E}_d is provided by flux in the direct axis. Equation (6) is based on the relation in the direct axis for which there is no excitation voltage, as is almost invariably the case. The corresponding current equations are given by (7) and (8). The expression for three-phase power in terms of terminal and excitation voltages can be obtained by eliminating I and ϕ from Eqs. (5), (6), and (8) with the result

$$P = 3 \frac{\bar{E}_t \bar{E}_d}{x_d} \sin \theta + 3 \frac{\bar{E}_t^2 (x_d - x_q)}{2x_d x_q} \sin 2\theta$$

which becomes

$$P = \frac{\bar{E}_t \bar{E}_d}{x_d} \sin \theta + \frac{\bar{E}_t^2 (x_d - x_q)}{2x_d x_q} \sin 2\theta \quad (9)$$

when the voltages are expressed as line-to-line voltages. All voltages are line-to-line values in the remainder of this section. The power limit for a single salient-pole machine connected to an infinite bus of maintained voltage \bar{E}_t can be obtained directly from Eq. (9). In a salient-pole machine the steady-state power limit is reached at an angle considerably less than 90 degrees. For the non-salient pole machine the quadrature-axis reactance x_q is equal to the direct-axis reactance x_d , which relation reduces the maximum power from Eq. (9) to the familiar form previously derived for the transmission line and given in Eq. (2).

$$P = \frac{\bar{E}_t \bar{E}_d}{x_d} \quad (10)$$

With two identical salient-pole synchronous machines at equal excitation, one acting as a generator, and the other as a motor, the terminal voltages and currents are in phase causing the angle ϕ to be zero. The power relation for this condition can be stated in terms of the terminal

voltage as given in Eq. (11) or in terms of the excitation voltage as given by Eq. (12).

$$P = \frac{\bar{E}_t^2}{x_q} \tan \theta \tag{11}$$

$$P = \frac{\bar{E}_d^2 \sin 2\theta}{x_q \left(\cos^2 \theta + \frac{x_d}{x_q} \sin^2 \theta \right)^2} \tag{12}$$

The maximum power that can be delivered by a system consisting of two identical salient-pole machines directly connected and operating at equal excitation is obtained from Eq. (13).

$$P = \frac{1}{2} \frac{\bar{E}_t^2}{x_d} F(\theta, x_d, x_q) \tag{13}$$

for which the value of the function $F(\theta, x_d, x_q)$ is plotted in Fig. 16. As a matter of interest the total angle between synchronous machine rotors, 2θ , at the point of pull-out is

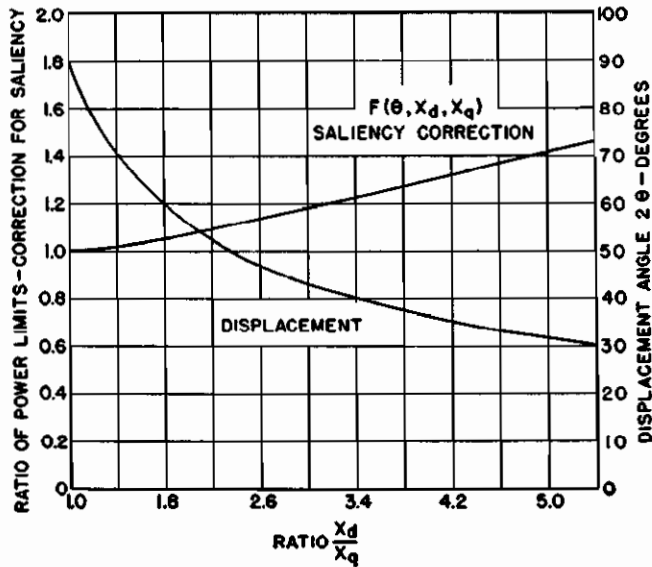

Fig. 16—Effect of saliency on power limit and total displacement angle for two identical machines operating at equal fixed excitation adjusted to maintain constant terminal voltage. Saliency effect plotted as ratio of power limit for various ratios x_d/x_q to values based on x_d alone.

also plotted in this figure. It will be noted that for $x_q = x_d$, Eq. (13) is identical in form with that previously derived for the steady-state stability limit and that the maximum power occurs at an angle of 90 degrees between the two machines and with an internal voltage equal to $\sqrt{2}$ times the terminal voltage. By using the internal voltages and the total reactance the same power expression would be obtained as previously given in terms of terminal voltage and the reactance of a single machine. Figure 16 is also useful as indicating the correction in the stability limit, which must be made because of the effect of saliency.

Example 1. Two salient-pole machines directly connected, three-phase, 2200 volt, 210 kva, operated at 1150 volts to avoid effects of saturation, with reactances of $x_d = 31.4$ ohms, $x_q = 8.83$ ohms. The stability limit as determined from the

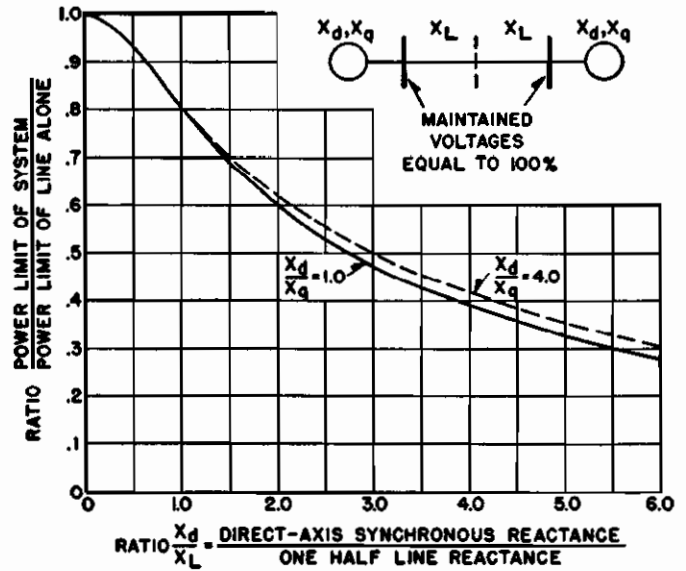

Fig. 17—Effect of machine reactance on power limits of transmission system with identical machines and fixed excitation. Curves plotted in terms of the reactance x_d and x_q of each machine and X_L of one-half of line.

terminal voltage and the direct-axis synchronous reactance only, using Eq. 13 with $x_q = x_d$, gives 42.3 kw. Using the correction factor obtained from Fig. 16, the stability limit considering the effect of saliency was calculated to be 52 kw. Actual tests made on these machines gave 52 kw.

The effect of saliency on the power limit of a transmission system is illustrated in Fig. 17. In this case the transmission system is assumed to consist of two identical machines, one operating as a generator and the other as a motor, with equal fixed excitation adjusted to maintain 100 percent terminal voltages as indicated in the insert of the figure. The power limits for such a system can conveniently be expressed in terms of the limit of the line alone. In Fig. 17 the solid-line curve is plotted for non-salient pole machines, i.e., with $x_q = x_d$; the dotted-line curve is plotted for a salient-pole machine for the relatively large ratio of x_d/x_q equal to four. The effect of saliency is small even for a ratio of x_d/x_q as high as four. For ratios of x_d/x_q between one and four the values will lie relatively close to the solid-line curve as the curve for saliency correction given in Fig. 16 suggests.

The foregoing discussion has presented sufficient formulas to permit the analysis of the difference in stability limits resulting from the saliency effect obtained by the two-reaction method in comparison with the results obtained by using the direct-axis reactance only. The reactances of synchronous machines given in Table 4 of Chap. 6 show that the ratio of x_d/x_q varies from one to an upper limit of approximately four. Under practical operating conditions this ratio is greatly reduced because of the effects of saturation. Furthermore, the power systems for which the steady-state stability limits are important almost invariably involve circuit elements that introduce impedance between the machines and which result in an important reduction in the effective ratio of the direct- and quadrature-axis reactances.

14. Effect of Saturation on Steady-State Stability

The effect of saturation on the equivalent synchronous reactance and corresponding internal voltage of synchronous machines is generally much more important than that of saliency. These effects from the stability standpoint are determined from the terminal voltage, power and reactive kva output, and the excitation characteristics of the machines as determined by test, or by recognized methods of calculating the regulation of synchronous machines as described in Chap. 6.

There are several methods of including the effects of saturation in the determination of pull-out power of a generator. The most accurate of these uses the voltage behind Potier reactance, E_p , to adjust the saturation of the ma-

chine at the pull-out point. This method of solution is described below along with some simplified methods of calculation. The results obtained by using the various methods are compared over a range of conditions to illustrate those cases where the simplified methods can be used with acceptable accuracy.

Potier Voltage Method—This method is best understood if the analysis is considered on the basis of the two existing operating conditions: the initial operating condition, and the pull-out operating condition. In Fig. 18 (a) is illustrated a generator G connected through its own reactance x_g to a terminal bus, which in turn is connected to an assumed infinite bus in the system through the equivalent external reactance x_e . The reactance x_e is the reactance of the system between the generator terminals and the infinite bus reduced to a single equivalent reactance. The internal voltage of the generator is represented by E_{int} .

The vector diagram for the system during the initial operating conditions prior to pull out is given in Fig. 18 (b). It is necessary, of course, to express all vector quantities on a common base, and the most convenient method of doing so is to use the per-unit system with the generator rating as a base. This is equivalent to referring to all voltages in terms of the generator field excitation required to produce them. The generator rated voltage, current, and kva are used for the base in expressing the voltages, currents, and reactances, respectively, as per-unit quantities. On this basis, 1.0 per-unit power converted to kilowatts is equal to the generator kva rating.

Referring to Fig. 18 (b), the following equations can be written. The infinite bus voltage E_r is the generator terminal voltage minus the drop through the external reactance,

$$E_r = E_t - Ix_e \tag{14}$$

The voltage behind Potier reactance E_p is equal to the terminal voltage plus the Potier reactance drop,

$$E_p = E_t + Ix_p \tag{15}$$

The internal voltage E_{int} of the generator is equal to the terminal voltage plus the drop through the generator unsaturated synchronous reactance,

$$E_{int} = E_t + Ix_d \tag{16}$$

The saturation curve of the generator is shown in Fig. 19 plotted in per unit. Rated generator voltage is used as 1.0 per-unit voltage, and the field current necessary to produce rated voltage on the air-gap line is 1.0 per-unit field current. The saturation \bar{S} is the difference between the excitation required to produce \bar{E}_p on the no-load saturation curve and the excitation required to produce \bar{E}_p on the air-gap line. The excitation voltage \bar{E}_x , which is equivalent to the total field current under the initial load condition, is the internal voltage plus the saturation,

$$\bar{E}_x = \bar{E}_{int} + \bar{S} \tag{17}$$

The power transferred from the generator to the infinite bus is

$$P = \frac{\bar{E}_{int} \bar{E}_r}{x_g + x_e} \sin \theta \tag{18}$$

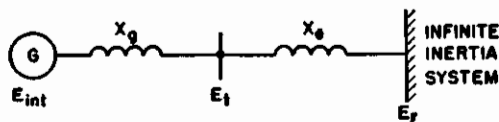

(a)

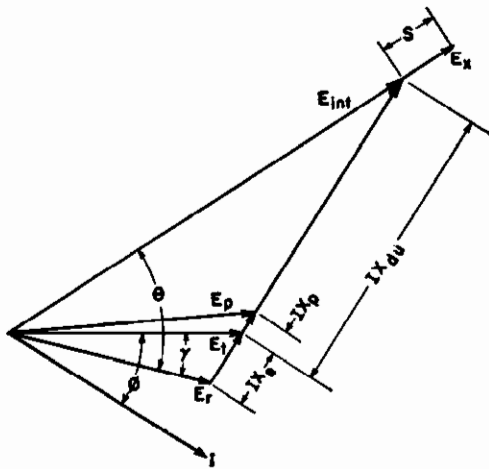

(b)

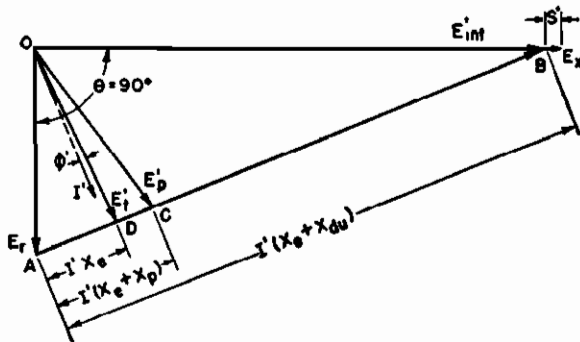

(c)

Fig. 18—Vector diagrams for initial-load and pull-out conditions.

- (a)—Equivalent representation of generator and external system.
- (b)—Vector diagram of system with generator loaded with rated kilowatts, power factor and voltage.
- (c)—Vector diagram at pull out with θ increased to 90 degrees and E_x and E_r equal to initial-load values in (b).

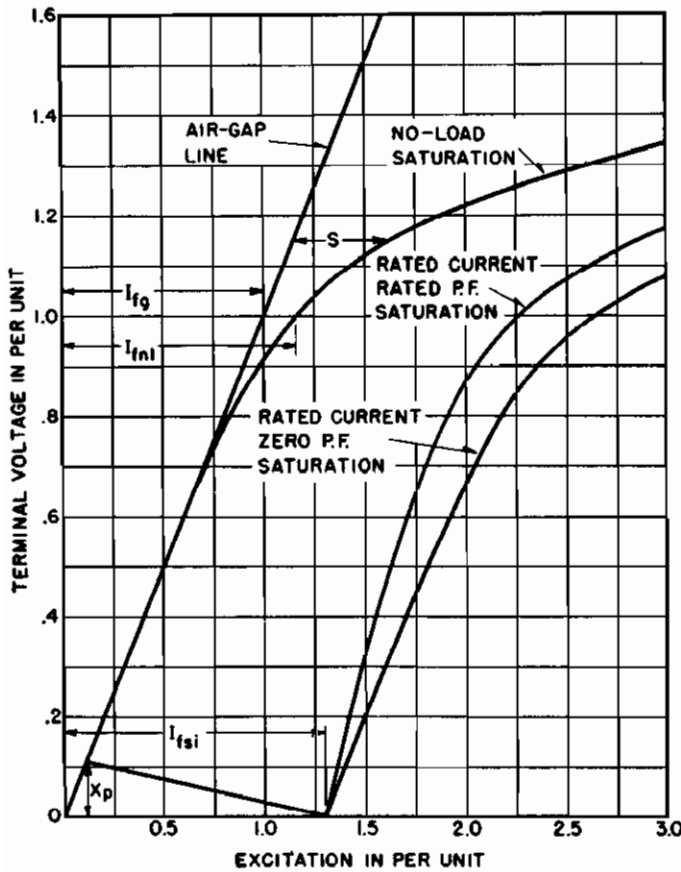

Fig. 19—Saturation curve of 60 000-kilowatt, 13 800-volt, 0.85-power factor generator used in the example of steady-state stability calculations.

where

$x_g = x_d$, the generator unsaturated synchronous reactance.

θ = Angle between E_r and E_{int} .

The generator power output is, of course, also found from the equation

$$P = \bar{E}_t \bar{I} \cos \phi \tag{19}$$

Under the hypothesis of constant excitation in the transition from the initial load condition to the pull-out condition, the excitation voltage \bar{E}_x remains constant. The infinite bus voltage \bar{E}_r is also assumed to remain constant, so that these two voltages and the reactances x_g , x_p , and x_o and the angle θ are the only quantities known at the time of pull out, and the internal voltage at pull out E'_{int} must be determined.

The vector diagram of the system at the time of maximum power transfer is given in Fig. 18 (c). The excitation voltage E_x is used as the reference vector and is equal in magnitude to the value calculated for the initial load condition. The angle θ is 90 degrees, so the infinite bus voltage E_r lags E_x by that angle. Expressions for the remainder of the vector diagram are

$$\bar{E}'_{int} = \bar{E}_x - \bar{S}' \tag{20}$$

$$I'(x_d + x_o) = E'_{int} - E_r \tag{21}$$

$$I' = \frac{E'_{int} - E_r}{x_d + x_o} \tag{22}$$

$$E'_t = E_r + I'x_o \tag{23}$$

$$E'_p = E_r + I'(x_o + x_p) \tag{24}$$

A method of successive approximations must be used to determine the value of \bar{S}' which leads to the correct solution of the vector diagram. First, a value is assumed for \bar{S}' and Eqs. (20), (21), (22), and (24) are used to calculate E'_p . The actual value of \bar{S}' is found from the saturation curve at a voltage equal to \bar{E}'_p and is compared with the assumed value. The assumed value is then adjusted until the actual value found by repeating the calculation of \bar{E}'_p is equal to the assumed value. Usually, two approximations yield a sufficiently accurate answer. When the correct values of \bar{S}' and \bar{E}'_{int} are found, the pull-out power can be calculated by

$$P_{max} = \frac{\bar{E}'_{int} \bar{E}_r}{x_d + x_o} \tag{25}$$

or

$$P_{max} = \bar{E}_t \bar{I} \cos \phi' \tag{26}$$

The application of the Potier voltage method is illustrated with an example in which G in Fig. 18 (a) is a 60 000-kw, 70 588-kva, 13 800-volts, 0.85-power factor, hydrogen-cooled turbine generator. The saturation curve of the generator is shown in Fig. 19. The equivalent system reactance x_o is 0.25 per unit on the generator rating of 70 588 kva. During the initial load conditions, the generator is assumed to be carrying 60 000 kw at 0.85 lagging power factor with its terminal voltage E_t maintained at rated value. The initial load data can be written as follows, using the generator rating as a base:

$$E_t = 13\ 800 \text{ volts} = 1.0 + j0.0 = 1.0 / 0^\circ \text{ per unit.}$$

$$\text{kw output} = 60\ 000 \text{ kw} = 0.85 \text{ per unit.}$$

$$\text{kva output} = 70\ 588 \text{ kva} = 1.0 \text{ per unit.}$$

$$I = 0.85 - j0.527 = 1.0 / -31.8^\circ \text{ per unit.}$$

$$\phi = 31.8^\circ.$$

$$x_o = 0.25 \text{ per unit.}$$

The required generator constants can be determined from the saturation curve:

$$x_d = \frac{I_{tsi}}{I_{tg}} = \frac{1.30}{1.00} = 1.30 \text{ per unit}$$

where

I_{tsi} = Field current required to produce rated armature current with a three-phase short circuit at the generator terminals.

I_{tg} = Field current required to produce rated voltage on the air-gap line.

The Potier reactance x_p is determined from the Potier voltage triangle as shown in Fig. 19 and is

$$x_p = 0.11 \text{ per unit.}$$

Referring to the vector diagram in Fig. 18 (b) and using Eqs. (14), (15), and (16),

$$\begin{aligned} E_r &= (1.0 + j0.0) - (0.85 - j0.527)(j0.25) \\ &= 0.8682 - j0.2125 = 0.894 \angle -13.77^\circ \\ \gamma &= 13.77^\circ \\ E_p &= (1.0 + j0.0) + (0.85 - j0.527)(j0.11) \\ &= 1.058 + j0.0935 = 1.062 \angle 5.06^\circ \\ E_{int} &= (1.0 + j0.0) + (0.85 - j0.527)(j1.30) \\ &= 1.685 + j1.105 = 2.015 \angle 33.25^\circ \\ \theta - \gamma &= 33.25^\circ \\ \theta &= 33.25^\circ + 13.77^\circ = 47.02^\circ \end{aligned}$$

From the saturation curve at a voltage equal to $\bar{E}_p = 1.062$ per unit, the saturation \bar{S} is 0.254 per unit, and from Eq. (17)

$$\bar{E}_x = 2.015 + 0.254 = 2.269$$

The above results can be used in Eq. (18) as a check to determine the accuracy of the calculations thus far:

$$\begin{aligned} P &= \frac{(2.015)(0.894)}{1.30 + 0.25} \sin 47.02^\circ \\ &= 0.8504 \text{ per unit.} \end{aligned}$$

The vector diagram for the pull-out condition is shown in Fig. 18 (c), and using E_x as a reference, the following quantities are known:

$$\begin{aligned} E_x &= 2.269 \angle 0^\circ = 2.269 + j0.0 \\ E_r &= 0.894 \angle -90^\circ = 0.0 - j0.894 \\ \theta &= 90^\circ \end{aligned}$$

Examination of the vector diagram reveals that \bar{E}_p' can be estimated by drawing the line AB , assuming \bar{S}' equal to zero, i.e., $\bar{E}'_{int} = \bar{E}_x$. The location of point C can be found from

$$\overline{AC} = \frac{x_o + x_p}{x_o + x_d} (\overline{AB})$$

The vector \overline{OC} is equal to E_p' , the voltage behind Potier reactance, and can be used to determine a value for the first approximation of \bar{S}' . Following this procedure, \bar{S}' is assumed to be 0.10 per unit. From Eqs. (20), (21), (22) and (24),

$$\begin{aligned} E'_{int} &= (2.269 + j0.0) - 0.10 \\ &= 2.169 + j0.0 = 2.169 \angle 0^\circ \\ I'(x_d + x_o) &= 2.169 + j0.894 = 2.347 \angle 22.4^\circ \\ I' &= \frac{2.169 + j0.894}{j1.30 + j0.25} \\ &= 0.577 - j1.400 = 1.514 \angle -67.6^\circ \\ E_p' &= (0.0 - j0.894) + (0.577 - j1.400)(j0.36) \\ &= 0.504 - j0.686 = 0.852 \angle -53.73^\circ \end{aligned}$$

From the saturation curve at $\bar{E}_p' = 0.852$ per unit, $\bar{S}' = 0.057$ per unit which shows that the first approximation was too high. A lower value, therefore, should be assumed for the second approximation, but observe that decreasing the value of \bar{S}' slightly increases the value of \bar{E}_p' . Thus, \bar{S}' is assumed as 0.06 per unit for the second approximation.

$$\begin{aligned} E'_{int} &= 2.209 + j0.0 = 2.20 \angle 0^\circ \\ I'(x_d + x_o) &= 2.209 + j0.894 = 2.385 \angle 22.0^\circ \\ I' &= 0.577 - j1.425 = 1.538 \angle -68.0^\circ \\ E_p' &= 0.513 - j0.686 = 0.857 \angle -53.2^\circ \\ \bar{S}' \text{ (from saturation curve)} &= 0.06 \\ E_t' &= (0.0 + j0.894) + (0.577 - j1.425)(j0.25) \\ &= 0.356 - j0.750 = 0.830 \angle -64.6^\circ \end{aligned}$$

The pull-out power for the assumed conditions is found from Eq. (25)

$$P_{max} = \frac{(2.209)(0.894)}{1.30 + 0.25} = 1.274 \text{ per unit}$$

or from Eq. (26) where

$$\begin{aligned} \phi' &= 68.0^\circ - 64.6^\circ = 3.40^\circ \\ P_{max} &= (0.830)(1.538) \cos 3.40^\circ = 1.274 \text{ per unit} \end{aligned}$$

The pull-out power in kilowatts is

$$P_{max} = (1.274)(70\,588) = 89\,930 \text{ kw.}$$

Many different initial operating conditions might be used to represent the system in a practical calculation. In the above example, where the generator terminal voltage was assumed as 1.0 and the kw load as 0.85, the margin obtained between the operating condition and the pull-out condition was $1.274 - 0.85$ or 0.424 per unit which is equivalent to 29 930 kw. The generator kw load, therefore, could be increased approximately 50 percent before the machine would pull out of step with the system. There may be other considerations such as turbine capability or generator heating that limit the load to some value below the maximum permissible power from the stability standpoint. If other initial operating conditions are assumed, the excitation voltage is, of course, changed, and the pull-out power differs from that obtained in the above example.

Synchronous Reactance Method—In this simplified method of steady-state stability calculation, the generator is represented by a reactance equal to the unsaturated synchronous reactance, x_d , and an internal voltage equal to the voltage behind unsaturated synchronous reactance, as determined by the initial load conditions. This voltage, E_d , is the same as E_{int} determined in Eq. (16). It is evident, therefore, that this method of calculation does not take into account the increase in E_{int} caused by the reduced saturation when the pull-out point is reached, and the maximum power so obtained is less than that given by the Potier voltage method. The maximum power equation becomes

$$P_{max} = \frac{\bar{E}_d \bar{E}_r}{x_d + x_o}$$

$$\text{where } E_d = E_t + Ix_d$$

calculated for the condition prior to pull out.

From the calculations in the example above,

$$\begin{aligned} \bar{E}_{int} &= \bar{E}_d = 2.015 \text{ per unit} \\ \bar{E}_r &= 0.894 \text{ per unit} \\ P_{max} &= \frac{(2.015)(0.894)}{1.30 + 0.25} = 1.162 \text{ per unit.} \end{aligned}$$

Short-Circuit Ratio Method—The short-circuit ratio (SCR) of a generator can be obtained from the saturation curve

$$SCR = \frac{I_{int}}{I_{ta}} \quad (27)$$

where

I_{int} = Field current required to produce rated voltage on the no-load saturation curve.

I_{tai} = Field current required to produce rated armature current with a three-phase short circuit at the generator terminals.

In this method of calculation, the generator reactance x_g is represented by the reciprocal of the generator short-circuit ratio,

$$x_g = \frac{1}{SCR}$$

The quantity $\frac{1}{SCR}$ is roughly equivalent to the generator unsaturated synchronous reactance, differing only in the fact that it takes into account a certain amount of saturation. The saturation included is that existing at rated voltage on the no-load saturation curve, and if this value of saturation is designated S_{nl} , it can be shown that

$$\frac{1}{SCR} = x_d \left(\frac{1}{1 + S_{nl}} \right)$$

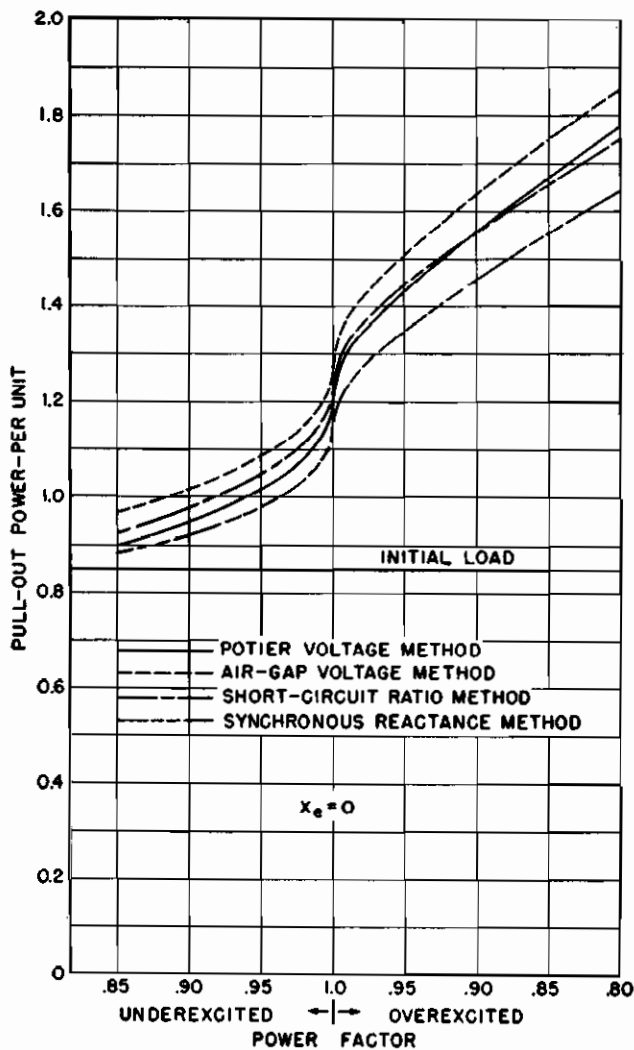

Fig. 20—Comparison of four methods of calculating pull-out power.
 $x_g = 0$ per unit

Initial load equal to 60 000 kw or 0.85 per unit at various power factors with terminal voltage E_t equal to 13 800 volts or 1.0 per unit.

In this method, therefore, a certain amount of correction for saturation at pullout is obtained, but it is a constant approximation, whereas the true saturation is variable depending on the operating conditions.

Internal voltage is calculated for the initial operating conditions from

$$E_{int} = E_t + I \left(\frac{1}{SCR} \right)$$

and the magnitude of the internal voltage at the pull-out point is assumed equal to the value so calculated. The maximum power equation is

$$P_{max} = \frac{\bar{E}_{int} \bar{E}_r}{\frac{1}{SCR} + x_g}$$

Applying this method to the example, the short-circuit ratio is found from the saturation curve and Eq. (27),

$$SCR = \frac{1.16}{1.30} = 0.892$$

$$x_g = 1.121 \text{ per unit}$$

$$E_{int} = (1.0 + j0.0) + (0.85 - j0.527)(j1.121)$$

$$= 1.591 + j0.953 = 1.854 \angle 30.9^\circ$$

$$P_{max} = \frac{(1.854)(0.894)}{1.121 + 0.25} = 1.209 \text{ per unit.}$$

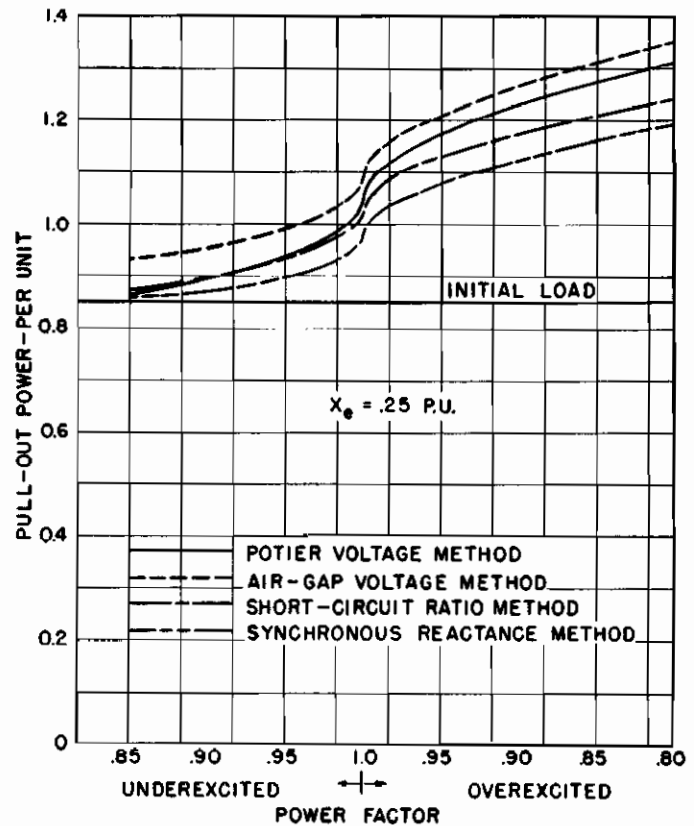

Fig. 21—Comparison of four methods of calculating pull-out power.
 $x_g = 0.25$ per unit

Initial load equal to 60 000 kw or 0.85 per unit at various power factors with terminal voltage E_t equal to 13 800 volts or 1.0 per unit.

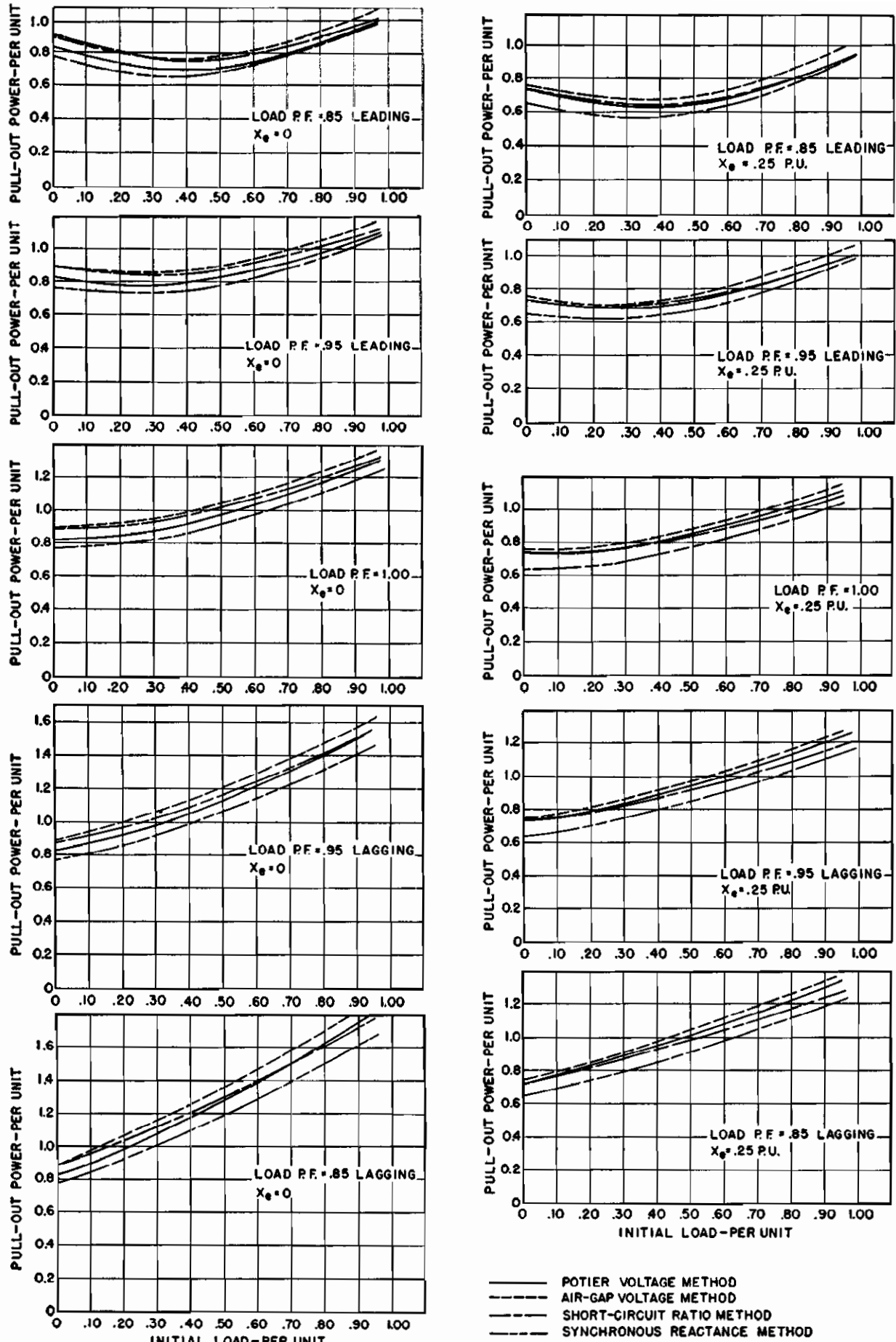

Fig. 22—Comparison of four methods of calculating pull-out power. Each curve is calculated for an initial-load condition of various kilowatts at the indicated power factor with the terminal voltage equal to 1.0 per unit.

Air-Gap Voltage Method—The use of the air-gap line voltage to represent the internal voltage of a generator in a steady-state stability study is based on the fact that there is usually little saturation existing at the time of pull out. The air-gap line voltage which is used is that voltage read on the air-gap line at a value of excitation equal to that required for the initial load condition. When expressed in per unit, this voltage is equal to the excitation voltage \bar{E}_x obtained in Eq. (17). The unsaturated synchronous reactance x_d is used to represent the generator reactance x_g . Thus, if there is any saturation in the machine at pull out, this method uses a voltage which is too high by the amount of the saturation to represent the internal voltage. The maximum power equation for this method is

$$P_{\max} = \frac{\bar{E}'_{\text{int}} \bar{E}_r}{x_d + x_e}$$

where

$$\bar{E}'_{\text{int}} = \bar{E}_x = \text{Voltage read on air-gap line at the field excitation required to produce the terminal voltage under conditions of load.}$$

In the example above, \bar{E}_x was found to be 2.269 per unit, and the maximum power is

$$P_{\max} = \frac{(2.269)(0.894)}{1.30 + 0.25} = 1.309 \text{ per unit.}$$

Comparison of Methods—Results obtained by calculating the pull-out power for a given kilowatt load at various power factors using the four methods are compared in Figs. 20 and 21. The 60 000-kw generator described in the example above was used in making the calculations. In all cases, the generator was assumed to be carrying 60 000 kilowatts at the specified power factor and with the terminal voltage maintained at rated value during the initial load condition. In the transition to the pull-out point, the infinite-bus voltage was assumed constant at the value calculated for the initial load condition. Figure 20 shows the results with the external reactance $x_e = 0$, and in Fig. 21, $x_e = 0.25$ per unit.

In all cases, the air-gap voltage method gives the highest value of pull-out power. This is to be expected since this method assumes no saturation at pull out and uses a voltage higher than actual to represent the generator internal voltage. The synchronous-reactance method, on the other hand, assumes that the saturation at pull out is equal to the saturation existing under the initial load condition and, consequently, represents the generator internal voltage by a voltage lower than the true value. The synchronous-reactance method, therefore, gives the lowest results in all cases. The actual value of pull-out power must be between the values obtained by these two methods, since one method considers no saturation while the other considers a high value of saturation.

The Potier-voltage method and the short-circuit ratio method give results within the limits set by the air-gap voltage and synchronous-reactance methods. Based on modern synchronous machine theory, the results of the Potier-voltage method are more accurate, because the saturation at pull out is adjusted to the proper value. The short-circuit ratio method gives results that compare

closely with the Potier-voltage method over the range of conditions studied.

A summary of a large number of calculations of pull-out power for the sample machine is given in Fig. 22. To obtain the data in each curve the generator power factor and terminal voltage were held constant for the initial load condition, while the generator load in kilowatts was varied. Study of these curves shows close agreement between the four calculating methods over the range of conditions included. Of particular interest is the fact that the result obtained by the short-circuit ratio method exceeded that obtained by the air-gap voltage method at low leading power factor and reduced load.

Extension of the Potier-Voltage Method—The Potier-voltage method as described above may appear to be a long and tedious procedure when a large number of conditions are being studied. The equations can, however, be modified for certain specific conditions and the calculations are then greatly simplified.

Frequently, it is desired to know the magnitude of field current or excitation voltage that must be maintained to prevent a generator from pulling out of synchronism. It has been shown that the pull-out power is a direct function of the excitation voltage less the saturation. A generator will pull out of synchronism when carrying a given kilowatt load if the excitation voltage is reduced below a certain minimum value. A curve of pull-out power as a function of excitation voltage is easily derived by the Potier-voltage method.

The first step in the procedure is to assume a value of pull-out power, P_{\max} , and determine the magnitude of internal voltage required to deliver that power by solving Eq. (25) for \bar{E}'_{int} :

$$\bar{E}'_{\text{int}} = \frac{P_{\max}}{\bar{E}_r} (x_d + x_e) \quad (28)$$

Referring to the vector diagram in Fig. 18 (c), two equations can be written:

$$-j\bar{E}_r + jI'(x_d + x_e) = \bar{E}'_{\text{int}} + j0 \quad (29)$$

$$\bar{E}_p' = -j\bar{E}_r + jI'(x_e + x_p) \quad (30)$$

Solving for I' in Eq. (29) and substituting in Eq. (30),

$$\bar{E}_p' = \sqrt{\bar{E}'_{\text{int}}{}^2 \left(\frac{x_p + x_e}{x_d + x_e} \right)^2 + \bar{E}_r^2 \left(\frac{x_p + x_e}{x_d + x_e} - 1 \right)^2}$$

Letting

$$K = \frac{x_p + x_e}{x_d + x_e} \quad (31)$$

$$\bar{E}_p' = \sqrt{\bar{E}'_{\text{int}}{}^2 K^2 + \bar{E}_r^2 (K - 1)^2} \quad (32)$$

In terms of the pull-out power, Eq. (32) converts to

$$\bar{E}_p' = \sqrt{\frac{P_{\max}^2}{\bar{E}_r^2} (x_p + x_e)^2 + \bar{E}_r^2 (K - 1)^2} \quad (33)$$

Using Eq. (28), therefore, the internal voltage is determined, and \bar{E}_p' , the voltage behind Potier reactance, is determined by using either Eq. (32) or Eq. (33). The saturation \bar{S}' is then read from the saturation curve at a voltage equal to \bar{E}_p' and added to the internal voltage to obtain the

excitation voltage as in Eq. (17). As pointed out previously, it is desirable that all calculations be done using per-unit values. When this is done, the excitation voltage obtained is in reality the per-unit field current required by the machine. The actual value of field voltage required can be obtained by multiplying the field current by the field resistance properly adjusted to take into account temperature effects.

As an example, this procedure can be applied to the 60 000-kw generator used above, and the field current determined for a maximum power of 1.25 per unit with the infinite bus voltage \bar{E}_r equal to 1.0 per unit and the external reactance equal to 0.25 per unit. From Eq. (28),

$$\bar{E}'_{int} = \frac{1.25}{1.0} (1.30 + 0.25) = 1.937 \text{ per unit.}$$

$$K = \frac{0.11 + 0.25}{1.30 + 0.25} = 0.2323.$$

From Eq. (32)

$$\bar{E}_p' = \sqrt{(1.937)^2 (0.2323)^2 + (1.0)^2 (0.2323 - 1.0)^2} = 0.890 \text{ per unit.}$$

From the saturation curve, \bar{S}' is 0.074 per unit, and the required excitation voltage or field current is $1.937 + 0.074 = 2.011$ per unit. One per unit field current on this generator is 332 amperes, so that the field current required would be 668 amperes, and the field voltage would be this current multiplied by the field resistance.

The results of a number of calculations of this type on the sample machine are plotted in Fig. 23 for three values of external reactance, to illustrate the manner in which the data can be presented. Because these curves give the value of field current for pull out, it is obvious that the generator

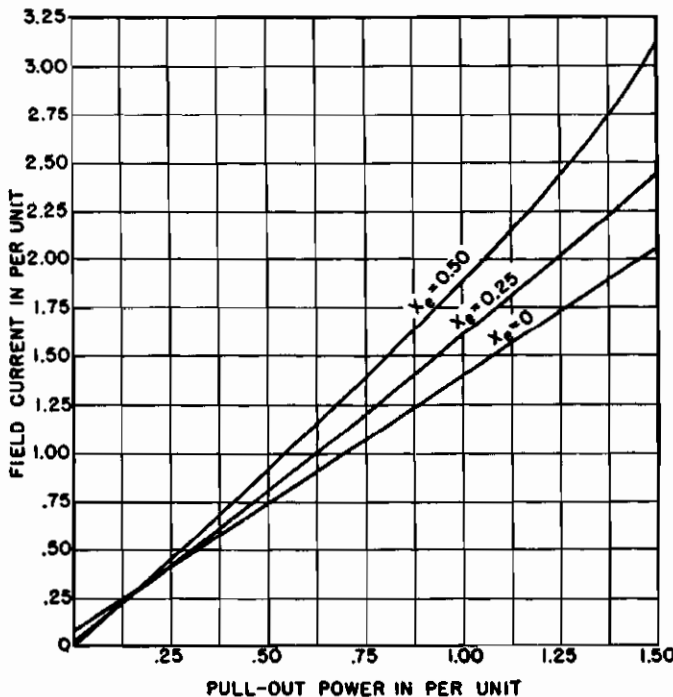

Fig. 23—Variation of pull-out power as generator field current is changed; calculated by Potier-voltage method with infinite bus voltage $E_r = 1.0$ per unit.

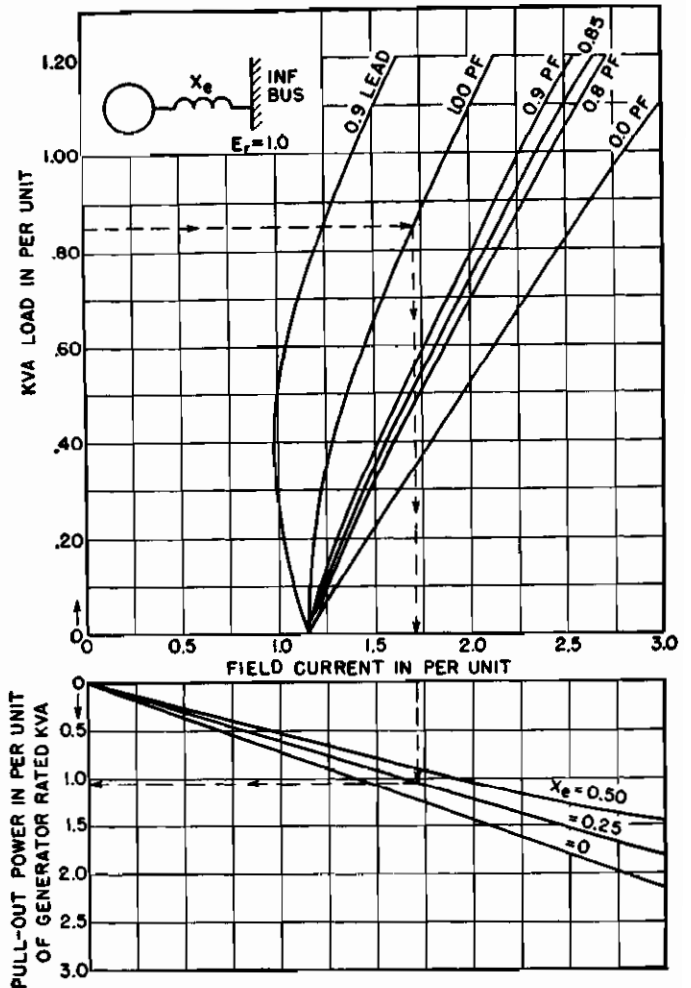

Fig. 24—Estimating curve for determining the pull-out power of an AIEE-ASME standardized turbine generator as a function of kva load and power factor.

- 1.0 per unit kva load = generator rated kva.
- 1.0 per unit Pull-out Power = generator rated kva.
- 1.0 per unit field current = field current required for rated voltage on air-gap line.

Find the point corresponding to the initial kva load on the upper ordinate and trace horizontally to the proper power factor line. Drop vertically to read field current on the abscissa and to intersect with proper external-reactance curve. Pull-out power is read on the lower ordinate. For 0.85 p.u. initial kva load at 1.0 pf., the pull-out power is 1.05 per unit and the field current is 1.72 per unit as found by following the dotted arrows. See text regarding accuracy of curves.

should be operated so as to maintain the field current high enough above the value indicated for the load being carried to provide sufficient pull-out margin. Methods of controlling the minimum excitation under voltage-regulator control and assuring sufficient field current for all kilowatt loads are discussed in Chap. 7.

Estimating Curves—The ASME-AIEE standardized designs of turbine generators are described in Chap. 6. These generators are designed for a rated power factor of 0.85 and a nominal short-circuit ratio of 0.80. The curve in Fig. 24 has been prepared for the purpose of quick-esti-

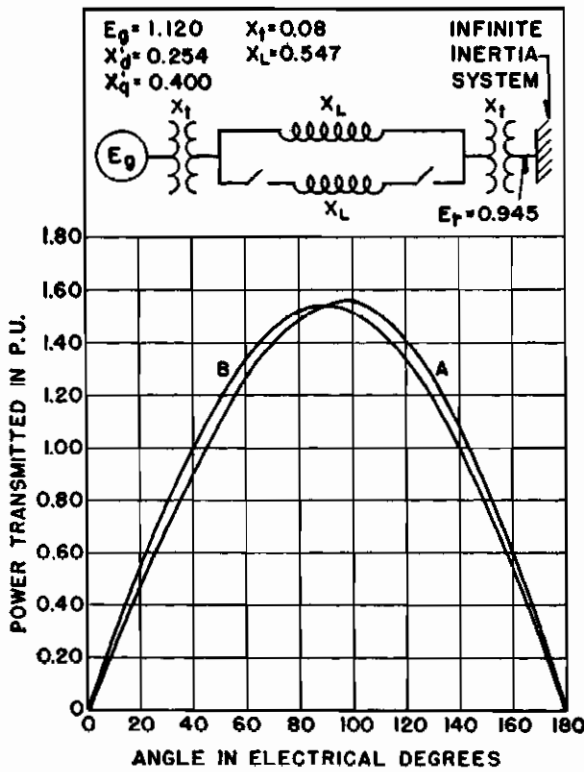

Fig. 26—Effect of saliency on transient stability for system shown in insert with both lines in service.

- A—Power-angle diagram based on initial load of 0.833 per unit—two-reaction theory.
- B—Power-angle diagram based on same initial load—round-rotor theory using same direct-axis transient reactance and corresponding internal voltage.

mental component of the power-angle curve is substantially the same in magnitude whether the round-rotor method or the two-reaction method is used.

Consider a simple transmission system*, such as shown in the insert of Fig. 26. Power-angle diagrams for this system have been calculated by the round-rotor and the two-reaction methods using the same values for x_d' in the machine and for the reactances of the remainder of the system. These power-angle diagrams for initial machine-conditions corresponding to a steady transmitted load of 0.833 per unit are shown in Fig. 26. In this case there is a difference of one percent in the power limit, the larger being obtained by the two-reaction method. The areas in the power-angle diagram for the initial output of 0.833 per unit are somewhat greater for the two-reaction method than for the round-rotor method. Furthermore, with the two-reaction method an appreciably greater percentage of this area occurs at a greater angle than with the round-rotor method. The power-angle curves show that the round-rotor method gives a conservative stability limit for the usual transient conditions. This is illustrated by Fig. 27 which is based on the system of Fig. 26 subjected to a double line-to-ground fault at the sending end. In this figure two curves are given for the stability limit plotted as a function

*This is identical with the system used in the single-machine problem, Sec. 24.

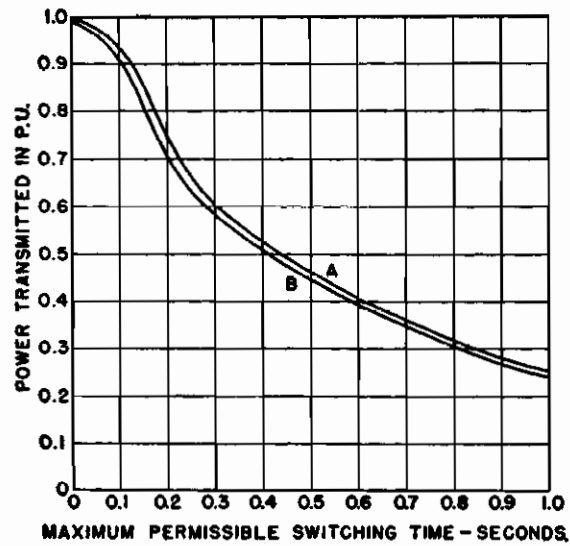

Fig. 27—Effect of saliency on permissible switching time—simultaneous clearing of line-section with double line-to-ground fault at sending end of system shown in Fig. 26.

- A—Two-reaction theory.
- B—Round-rotor theory.

of the duration of fault using both the round-rotor and two-reaction methods. These curves show that there is little difference in the stability limit or the permissible switching time, but the values are somewhat greater when calculated by the two-reaction method. If salient-pole machines were used at both ends of the system, the effect of saliency would be of greater importance. However, for the majority of problems the round-rotor method is satisfactory because it gives a conservative stability limit and is preferable because the calculations are much simpler.

16. Effect of Saturation on Transient Stability

Machine saturation affects transient stability by reducing the magnitude of transient reactances. As brought out in Chap. 6, the unsaturated transient reactance is rarely useful. The two commonly available and useful values of transient reactance are (1) the "rated-current value" obtained by short-circuiting a machine at the appropriate reduced excitation, and (2) the "rated-voltage value" obtained by short-circuiting the machine from no load but with excitation corresponding to rated voltage. The difference in these reactances results from saturation arising from the difference in excitation, the higher value being for the lower excitation. The rated-voltage value is the one commonly used for short-circuit calculations and, therefore, is generally available. Actually the variation in the value of transient reactance caused by saturation is not large and it is preferable in stability studies to use a conservative, that is, the higher value. It is possible to include the effect of saturation in the estimate of the transient reactance corresponding to the particular excitation and of armature current as discussed in Chap. 6. Practically,

however, there is little difference for the range of currents commonly encountered. For this reason it is usually sufficiently accurate to use the "rated-current value."

17. Dynamic Stability with Automatic Devices

When synchronous machines are operated with voltage regulators, the stability limits of the system are importantly changed from the values which obtain for hand control. This phenomenon has been designated "dynamic stability with automatic devices." Dynamic stability on power systems is made possible by the action of voltage regulators that are capable of increasing or decreasing flux within a machine at a faster rate than that caused by the system in falling out of step. When the inherent stability limit is exceeded, both the mechanical system and the electrical system are maintained in a continuous state of oscillation through the development of restoring forces equal to or greater than the disturbing forces.

This conception of dynamic stability was first recognized by E. B. Shand, but at the time it was not thought to lie within the range encountered with commercial equipment. Subsequently, Evans and Wagner* demonstrated by analytical methods and by miniature-system tests that substantial improvement in stability limits could be obtained by making use of this phenomenon. Their tests, reported in 1926, showed that the stability limits of a transmission system with a 200-mile transmission line could be increased 25 percent by this method. Later Doherty⁷ and Nickle made tests for the special and rather academic condition of two machines directly connected, which showed that the limits could be increased about 300 percent by the same means. These two tests are actually quite comparable when the effects of line reactances are considered.

Dynamic stability with automatic devices can be considered as a problem in transient stability, making use of the machine air-gap flux and a reactance intermediate between the familiar synchronous and transient reactances. With ideal excitation systems, that is, with voltage regulators without time lag, with high frequency of operation, and with unlimited exciter range and response, the stability limit would be determined by the transient reactance. From a practical standpoint the exciter response is not sufficiently fast to approach closely the ideal condition. More important, however, is the inability of the regulator to approximate the ideal characteristics because of the time delay and the finite steps of regulator action, and delay in the anti-hunting feature. This provides a definite limit to the increase in the stability limit resulting from regulator action. Nevertheless, for the system consisting of two machines, as described in Ex. 1 of Sec. 13, operating at equal excitation and constant terminal voltage under the control of a voltage regulator, the stability limit was raised with automatic devices from 52 to 183 kilowatts. The importance of the increase in stability limits due to the operation of automatic devices is, of course, greatly reduced when appreciable reactance is introduced between the sending and receiving systems. For example, Fig. 28 shows the effect of introducing line reactance between the two machines just described. For a discussion of operation in the zone of dynamic sta-

*Reference 5; test results reported in closing discussion.

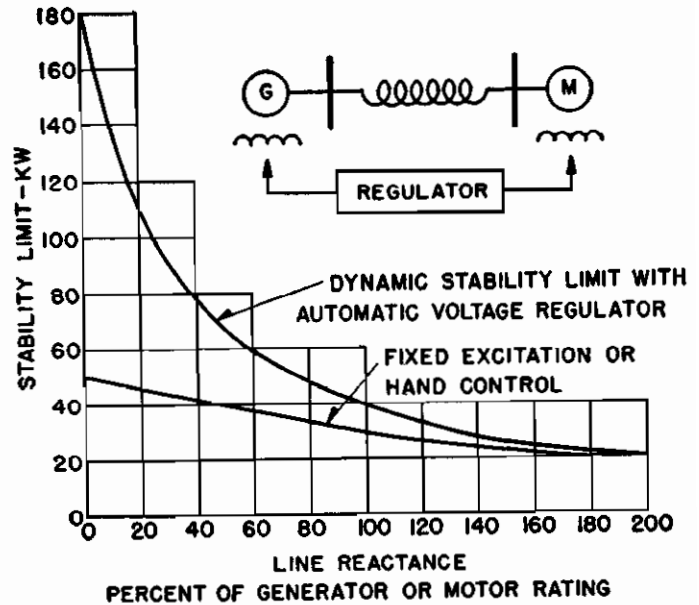

Fig. 28—Comparison of stability limit with automatic voltage regulator and limit with fixed excitation or hand control. Shows gain due to "Dynamic Stability."

bility,⁸ reference should also be made to the second part of Sec. 47 under Excitation Systems.

18. Hunting of Synchronous Machines

The hunting of synchronous machines can arise from phenomena closely related to system stability. In the early stages of power-system development it was difficult to differentiate between hunting and instability. The term "hunting" is now commonly restricted to two phenomena, which may be designated as

- (1) Hunting from spontaneous action, and
- (2) Hunting from pulsating torques.

The first of these phenomena was observed in connection with the operation of synchronous converters when supplied over "shoe-string lines." It was found that the hunting could be overcome (1) by limiting the resistance drop of these lines to a certain percent of the total reactance drop, or (2) by the use of suitable damper windings. Spontaneous hunting is still encountered occasionally, principally in connection with high-resistance lines or in connection with series capacitors as a result of which the resistance sometimes becomes relatively large through the neutralization of inductive reactance. The phenomenon of spontaneous hunting is now well understood, and the conditions under which it can occur can now be expressed in mathematical form.¹⁹

The hunting that results from pulsating torques is a phenomenon which today is of much less importance than it was when reciprocating types of prime movers were used. These pulsations have been minimized by the use of greater inertia and the use of damper windings. The development of the continuous-torque prime movers of the turbine type for both steam and hydro-electric installations substantially eliminated the problem in connection with these prime movers. At present the problem is occa-

sionally encountered in connection with Diesel-engine prime movers or with certain types of pulsating loads. The phenomenon may be analyzed by methods outlined in this chapter for a study of transient stability by using the known pulsating-torque characteristic of the prime mover or of the load, and the electro-mechanical equations or the electric-circuit equivalents.

Natural Frequency of Synchronous Machines*—

The natural frequency of undamped electro-mechanical oscillation for a synchronous machine connected to an infinite bus and shaft-connected to reciprocating machinery is given by

$$f_n = \frac{35\,200}{n} \sqrt{\frac{P_r f}{WR^2}} \quad (34)$$

where

f_n = Natural frequency in cycles per minute.

n = Speed of machine in revolutions per minute.

P_r = Synchronizing power as defined below.

f = Frequency of circuit in cycles per second.

WR^2 = Moment of inertia of synchronous machine and shaft-connected prime mover or load, in lbs-ft².

The synchronizing power is the power at synchronous speed corresponding to the torque developed at the air gap between the armature and field. The synchronizing coefficient P_r is determined by dividing the shaft power in kw by the corresponding angular displacement of the rotor in electrical radians. P_r , therefore, is expressed in kw per electrical radian. The displacement angle of the rotor for a given current and power factor is

$$\delta = \tan^{-1} \frac{\bar{I}x_q \cos \phi}{E_t + \bar{I}x_q \sin \phi}$$

where

δ = Rotor displacement angle in electrical radians.

\bar{I} = Per-unit armature current.

E_t = Per-unit armature terminal voltage.

ϕ = Power-factor angle.

x_q = Per-unit quadrature-axis synchronous reactance.

The value of P_r determined by this method is quite generally applicable for predicting operation at full load, particularly where the amplitude and frequency of the power pulsations are low. The value of P_r at no load with the field excitation corresponding to normal open-circuit voltage may be taken as normal rated kva divided by x_q . The variation of P_r from no load to full load is approximately linear when the terminal voltage and power factor are held constant.

19. Governors

At present, prime movers for waterwheel and turbine generators are under the control of governors that respond to variation in speed or frequency. Some prime movers are operated on a mechanically-limited valve opening or "block" and an adjustment of the governor for that particular unit to regulate for a frequency somewhat above the system so that the unit operates to give the maximum prime-mover input corresponding to the de-

*American Standard for Rotating Electrical Machinery, ASA, C-50, 1943, page 28.

sired block. A governor under such a setting is, of course, operative to limit overspeed, the control becoming effective at a frequency slightly above the normal frequency. Governors are relatively slow in action with respect to the time elements which are important from the standpoint of power-system oscillations. For this reason governors are usually not important from the standpoint of transient stability. In the case of hydro-electric plants, because of the large amount of energy stored in the water column it is impracticable for the governor to limit rapidly the prime-mover input, although by-passing action can be effected more rapidly. Proposals for faster action have been made, but by-passing arrangements as built are too slow to be beneficial from the standpoint of stability. In the case of steam turbines, there is somewhat greater possibility of control. However, in many plants the amount of energy stored in the steam in the piping and various high- and low-pressure units, limits the benefits that might be obtained.

Governors, however, have an important effect on steady-state stability as a result of their control of the division of increments of load among the various generating units. It is necessary, therefore, to give consideration to the actual distribution of the incremental load when the stability limit is being approached. Furthermore, where loads and generating equipment are distributed throughout a network, a large difference of phase is sometimes introduced between the principal generating stations on the system. Under such conditions a system fault can sometimes produce a severe oscillation and result in instability. Such a condition can be avoided by control³⁸ of the phase angle between the machines so as to limit the initial angle between principal generating stations to a safe value for the initial condition, that is, prior to the fault.

Governors may introduce a disturbing factor and tend to produce hunting and even loss of synchronism. This condition produced by governor action is identical with the other forms of pulsating disturbances applied to a system and discussed in Sec. 18, Hunting of Synchronous Machines. The adjustment of the governor is an important factor in preventing any tendency toward hunting action. The time lag of the governor and its natural period of movement, if closely related to that natural period of the system, can contribute to hunting action.

If a machine pulls out of step with the remainder of the system, the governor is called into action by the over-speeding of the machine. The slipping of poles produces a pulsating disturbance of low frequency¹⁵, which the governor can or cannot follow, depending upon its adjustment. For this reason radically different results can be obtained when two generally similar generators pull out of step. There is, therefore, some advantage in adjusting governors so as to minimize the resulting disturbance to the system in the event of the machine losing synchronism.

20. Calculation of System Oscillations

The electro-mechanical oscillations produced by a transient disturbance on a two-machine system are very complicated. The formal mathematical solution of these os-

cillations is not possible as even the simplest cases involve elliptical integrals. The solution, however, can be obtained to any desired degree of accuracy by step-by-step approximate methods discussed subsequently in Sec. 23. The relations of the principal variables can readily be visualized by curves that give the acceleration, velocity, and displacement as a function of time. For this purpose it is convenient to think of an oscillation for which the change in power and angle are linear as shown in Fig. 29 (a). The time variation of acceleration, velocity, and

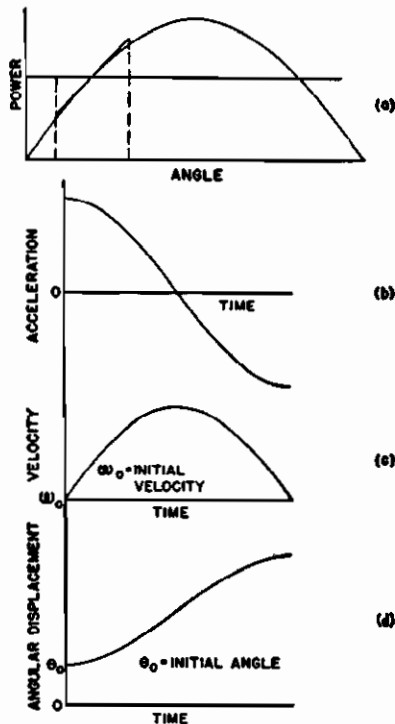

Fig. 29—Graphical solution of system oscillation

displacement are given in Fig. 29 (b) to (d). For the case chosen the quantities plotted are simple sine and cosine curves. Simple relations exist between these curves that can be derived from the basic laws of motion. Thus the change in velocity is proportional to the square root of the integral of the acceleration-angle curve, and the displacement is a function of the integral of the velocity curve.*

For the practical cases the simple trigonometric relations do not hold because the power-angle relation is not linear. However, curves similar to those of Fig. 29 (b), (c), and (d) can still be plotted, and they will help to give a picture of the variations in these quantities.

*These relations provide the basis for a graphical method proposed by Skilling and Yamakawa²⁰ for obtaining velocity-angle and time-angle curves. This method has certain advantages in comparison with a step-by-step method from the standpoint of formal mathematical presentation. It can readily be used to provide a check on the suitability of interval used in step-by-step analysis, since velocity is proportional to the square root of the integral of the acceleration-angle curve. The method is not applicable to a system with more than two machines and for this reason has not been presented in detail.

21. Use of Angle-Time or Swing Curves

Angle-time or swing curves may be calculated by means of the step-by-step procedure discussed in Sec. 23. These curves show the angular position of the rotor(s) plotted against time measured from the inception of a fault. Figure 36 is an example of an angle-time curve.

If a two-machine system is subjected to a switching transient as shown in Fig. 6, it is possible to determine by the "equal-area method" previously discussed, whether the system is stable. This answer, it will be noted, would be obtained without a knowledge of the time variation of the various electro-mechanical quantities. Similarly, if a two-machine system is subjected to a transient disturbance involving a fault with subsequent clearing, as illustrated in Fig. 7, it is also possible to determine whether the system is stable. In this case the duration of the various fault conditions must be expressed in terms of the angular swing. From a practical standpoint such information is not generally available because faults are cleared as a function of time measured from the application of the fault. Determination of this time requires solution of the electro-mechanical oscillation. Examination of the angle-time curves for a particular system subjected to a specified disturbance not only establishes whether the system is stable, but if stable it provides some basis for estimating the margin of stability as well. The angle-time or "swing curves" also provide a basis for estimating the magnitude of the voltage, current, power, and other quantities throughout the disturbance, which information is frequently of great value in circuit-breaker and relay applications.

The determination of angle-time curves is carried out by approximating methods either analytically or with the aid of the a-c network calculator. The essential parts of these methods are the same, since calculations in both cases are carried out by step-by-step methods. In this method small intervals are taken so that the accelerating forces can be assumed constant within the interval. On this basis it is a simple problem in mechanics to determine for each step the change in position of the rotor of each machine as a result of the accelerating or decelerating forces, the inertia of the machine, and the duration of the interval.

22. Inertia Constants and Acceleration

By means of the methods previously described, it is possible to reduce the electrical input or output of each machine to a simple power-angle curve or a simple trigonometric expression with the angle between internal emf's as the variable. The accelerating power depends upon the initial operating condition and upon the difference between input and output, including the effect of losses. Thus, for a generator the accelerating power, which is the variable ΔP , is

$$\Delta P = P_i - (P_o + L) \quad (35)$$

where P_i is the mechanical input, P_o is the electrical output, and L is the total loss. In the case of a synchronous motor the equation is similar in meaning, but the numerical sign of the accelerating forces is negative when the input is less than the output plus the losses. Losses are, however, often neglected.

The inertia of synchronous machines varies through a wide range depending principally upon the capacity and speed and upon whether additional inertia has been intentionally added. Fortunately, however, the constants vary through a relatively narrow range if they are expressed in terms of the stored energy per kva of capacity. The relation between the stored energy constant*, H , and WR^2 is given by the following equation:

$$H = \frac{\text{kW-sec}}{\text{kva}} = 0.231 \frac{(WR^2)(\text{rpm})^2 \times 10^{-6}}{\text{kva}} \quad (36)$$

where WR^2 is the moment of inertia in pounds-feet squared, and rpm is the speed in revolutions per minute. The inertia constants vary through a range of from less than one to about ten kilowatt-seconds per kva, depending upon the type of apparatus and the speed. Since control of the inertia is one of the possible methods of improving the stability of the system, the subject of inertia constants is discussed at some length under the first part of Sec. 47 dealing with measures for improving system stability. Reference should also be made to Chap. 6, Part XIII, for further information on inertia constants which can be used in preliminary work or in the absence of specific information applying to the machine under consideration.

Frequently it is convenient when neglecting loss to replace a system of two machines, each with finite inertia, by another system consisting of one machine with an equivalent inertia and a second machine with infinite inertia. By this means the problem is reduced to that of a single-machine system.⁵ If the stored energies of the machines are $(H_a \text{kva}_a)$ and $(H_b \text{kva}_b)$, then the equivalent inertia constant for one of them, $H_{\text{eq(a)}}$ is given by

$$H_{\text{eq(a)}} = \frac{H_a}{1 + \frac{H_a \text{kva}_a}{H_b \text{kva}_b}} \quad (37)$$

In this method the acceleration, velocity, and phase relation of the selected machine are obtained in relation to the other machine as reference. When losses, intermediate loads, or more than two machines are involved, it is necessary to use the more general method whereby the absolute acceleration, velocity, and phase relation for each machine are separately determined as discussed in the following section.

With the inertia constant, H , and the accelerating or decelerating power, ΔP , it is possible to compute the acceleration by means of the following important formula:

$$\alpha = \frac{(180)(f)(\Delta P)}{(H)(\text{kva})} \quad (38)$$

where α is the acceleration or deceleration in electrical degrees per second per second, f is the system frequency in cycles per second, ΔP is the kilowatts available for acceleration (or deceleration), H is the inertia constant in kilowatt-seconds per kva as obtained from Eq. (36).

23. Step-by-Step Procedure

The step-by-step procedure^{2,5,12,36} can be carried out in

*The formulas for acceleration and inertia constants are based on the forms presented in the "First Report of Power System Stability," Reference 33.

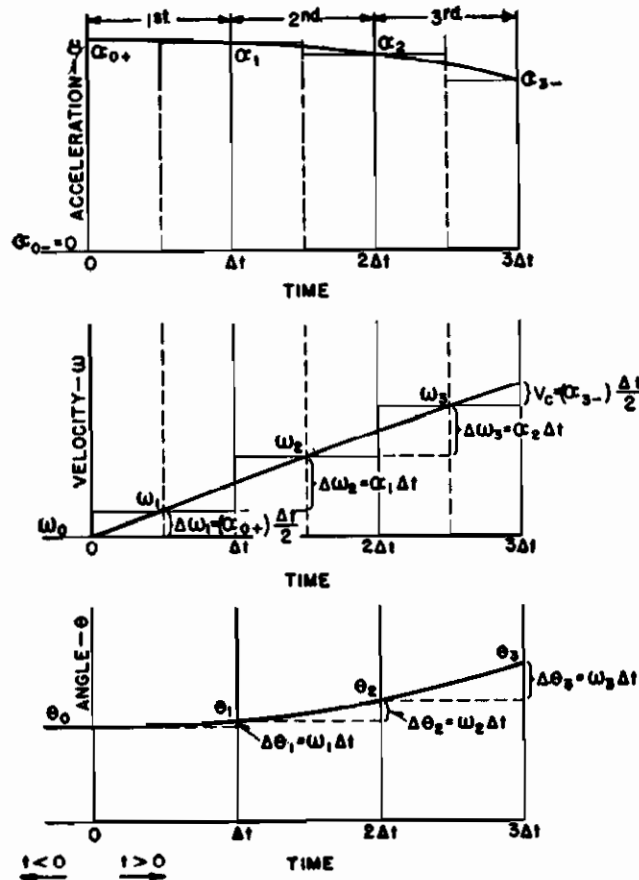

Fig. 30—Step-by-step solution—details of method for approximating acceleration, velocity, and angle changes.

NOTE: For computing velocity at the end of an interval, it is necessary to add a correction term to include change in velocity from the middle to the end of the interval as shown by V_c for the third interval.

many ways, depending upon the particular set of assumptions used to minimize the error resulting from the approximation. The following procedure is the one we have found to be the most suitable for transient-stability studies using the a-c network calculator. In studying the step-by-step method, it is suggested that consideration be given first to its application to a single-machine system, that is, a two-machine system for which one machine is of infinite inertia. Reference should be made to Fig. 30, which shows for a particular machine the variation of acceleration, velocity, and angle of rotor with respect to the other machine which is assumed to be of infinite inertia. The method upon which this figure is based can readily be modified to apply to the general case of two machines of finite inertia by making allowance for the changes in the positions of the rotor of the other machine. The calculations are arranged in tabular form as shown in Table 2. Two similar tabulations are required for a two-machine system, one for each machine. The calculation for a particular machine is tied in with that for the other machine by means of Column 11 of the tabulation, which is obtained from Column 10 of the tabulation for the other machine. If one of the machines is assumed to be of infinite inertia, the problem reduces to that of a single-machine system, and only one tabulation is

TABLE 2—SUGGESTED FORM FOR STEP-BY-STEP ANGLE-TIME CALCULATIONS

Station _____ Machine Nos. _____ Total Kva _____
 Machine, $WR^2 =$ _____ lbs-ft²
 $H =$ _____ stored energy, kilowatt-seconds per kva
 Acceleration, $\alpha = \frac{180(f)(\Delta P)}{(H)(kva)} = k\Delta P$, degrees per second per second
 $k = \frac{180 f}{(H)(kva)} =$ _____
 $P_{Mech.} =$ _____ kilowatts, mechanical input

(1)	(2)	(3)	(4)	(5)	(6)	(7)	(8)	(9)	(10)	(11)	(12)
Time Sec	Angle θ Degrees	Elec. Output plus losses* kw	ΔP , kw Mechanical Input minus (Electrical Output plus losses)	Accel., α Degrees per Sec per Sec	Accel. Time Increment	Vel. change, $\Delta\omega$, Degrees per Sec	Velocity ω , Degrees per Sec	Angle Time Increment	Angular Change for Machine Under Consideration, $\Delta\theta$, Degrees	Angular Change for Other Machine $\Delta\theta'$, Degrees	Final Angle θ , Degrees
—	—	—	$P_{Mech.} - (3)$	$(4) \times k$	—	$(5) \times (6)$	$(7) + (8)_{n-1}$	—	$(8) \times (9)$	**	$(2) + (10) + (11)$
0.0	θ_0	P_0	$P_{Mech.} - P_0$	$k\Delta P_0 = \alpha_{0+}$	$\Delta t/2$	$\Delta\omega_1$	$\omega_0 + \Delta\omega_1 = \omega_1$	Δt	$\omega_1 \Delta t = \Delta\theta_1$	$\Delta\theta_1'$	$\theta_0 + \Delta\theta_1 + \Delta\theta_1' = \theta_1$
0.1	θ_1	P_1	$P_{Mech.} - P_1$	$k\Delta P_1 = \alpha_1$	Δt	$\Delta\omega_2$	$\omega_1 + \Delta\omega_2 = \omega_2$	Δt	$\omega_2 \Delta t = \Delta\theta_2$	$\Delta\theta_2'$	$\theta_1 + \Delta\theta_2 + \Delta\theta_2' = \theta_2$
0.2	θ_2	P_2	$P_{Mech.} - P_2$	$k\Delta P_2 = \alpha_2$	Δt	$\Delta\omega_3$	$\omega_2 + \Delta\omega_3 = \omega_3$	Δt	$\omega_3 \Delta t = \Delta\theta_3$	$\Delta\theta_3'$	$\theta_2 + \Delta\theta_3 + \Delta\theta_3' = \theta_3$
0.3—	θ_3	P_{3-}	$P_{Mech.} - P_{3-}$	$k\Delta P_{3-} = \alpha_{3-}$	$\Delta t/2$	V_0	$\omega_3 + V_0$	—	—	—	—
0.3+	θ_3	P_{3+}	$P_{Mech.} - P_{3+}$	$k\Delta P_{3+} = \alpha_{3+}$	$\Delta t/2$	$\Delta\omega_4$	$\omega_3 + (V_0 + \Delta\omega_4) = \omega_4$	Δt	$\omega_4 \Delta t = \Delta\theta_4$	$\Delta\theta_4'$	$\theta_3 + \Delta\theta_4 + \Delta\theta_4' = \theta_4$
0.4	θ_4	P_4	$P_{Mech.} - P_4$	$k\Delta P_4 = \alpha_4$	Δt	$\Delta\omega_5$	$\omega_4 + \Delta\omega_5 = \omega_5$	Δt	$\omega_5 \Delta t = \Delta\theta_5$	$\Delta\theta_5'$	$\theta_4 + \Delta\theta_5 + \Delta\theta_5' = \theta_5$
0.5	θ_5										

See Fig. 30 for meaning of α , ω , $\Delta\omega$, θ and $\Delta\theta$ terms.

*Losses are often neglected where they are small compared to the machine output during the fault.

**These values obtained from similar tabulation for other machine.

required, as $\Delta\theta'$, the angular change for the other machine, can be taken as zero.

In Fig. 30 three intervals in the step-by-step method are shown, and a circuit change is assumed to take place at the end of the third interval. The velocities ω_1 , ω_2 , and ω_3 are assumed to remain constant through the corresponding three intervals. The acceleration on the other hand is assumed to remain constant from the middle of one interval to the middle of the subsequent interval. By this means acceleration is chosen to be alternately greater and less than the actual value as shown by the plotted curve. Such an arrangement is used to minimize the cumulative error.

The initial acceleration α_{0+} is computed from the power flow corresponding to the phase position at the beginning of the transient disturbance which takes place at $t=0$. This acceleration is then used for half of the first time interval Δt to determine the velocity ω_1 which is assumed throughout the interval. The angular change $\Delta\theta_1$ for the particular machine is then computed from the average velocity during the interval. Similar calculations are then made for the other machine to determine its angular change $\Delta\theta_1'$ during the same interval. The final angle, the angle θ_1 , at the end of the first interval, is the sum of the initial angle θ_0 and the angular displacements $\Delta\theta_1$ and $\Delta\theta_1'$ for the two machines.

The calculations for the second interval are made in a similar manner. The acceleration α_1 is computed with the aid of the angle θ_1 obtained at the end of the first interval. Next the increment in velocity is obtained by assuming

the acceleration α_1 through the interval Δt . This velocity is then used to compute the change in angle taking place through the second interval, which is equal to the velocity ω_2 times the increment of time Δt .

This process is repeated for each step throughout any period for which the circuit is not changed or for which the same time interval is used. If there is a change of either condition, it is necessary to compute a velocity correction term since, as pointed out previously, velocities are computed for the middle of the interval while acceleration and angular displacement are computed for the end of the interval. For the case illustrated in Fig. 30 the circuit is assumed to be changed at the end of the third interval. Consequently, it is necessary to add a correction term V_0 to the velocity ω_3 to obtain the velocity at the end of the third interval as shown in the figure.

The fourth and subsequent intervals can be computed as for the first and subsequent intervals. To distinguish between the acceleration rates corresponding to the beginning of an interval or the end of the preceding interval, the practice has been followed of using plus and minus signs respectively. This procedure has been applied to the case under consideration using the terms α_{0+} and α_{0-} at zero time. In this case the acceleration α_{0-} is zero since it is assumed that the system is in equilibrium prior to the application of the transient at the time $t=0$, and the acceleration α_{0+} applies upon the application of the transient. The term α_{3-} gives acceleration at the end of the third interval prior to the circuit change, and the term α_{3+} gives

the acceleration subsequent to the circuit change. Ordinarily the plus and minus signs should be omitted, and in that case the term is understood to give the acceleration at the end of the interval indicated by the subscript.

The time interval to be used in the step-by-step analysis is a matter of judgment and convenience. In the ordinary stability problem the interval should not be longer than 0.1 second, which is a convenient interval since it gives the time in an even number of cycles. For some applications it is desirable to shorten the interval to 0.05 second, which corresponds to three cycles. The time interval can be changed from point to point throughout the transient disturbance. For example, during one part of a disturbance involving some circuit changes there can be little relative change in angular position, and relatively large intervals can be permitted. Conversely, other transient conditions can introduce large changes in angle during an interval. As a practical matter, the length of the interval should always be decreased if the change results in an angular swing of 20 degrees to 30 degrees in a single interval. The velocity-angle curve for two-machine systems can be plotted and compared with the results of calculation by the method of Skilling and Yamakawa.³⁹

The labor of making a step-by-step calculation will be reduced greatly by arranging the work in tabular form. For this reason Table 2 has been introduced. This table is based on the procedure found desirable in a-c network calculator studies and can be supplemented by additional columns if this is desirable to facilitate the calculation of the output power which in the table is assumed to have been obtained from the a-c network calculator readings or from calculated power-angle curves. The calculations have been arranged so that velocity and acceleration curves can be plotted readily; this has been found desirable in a sufficient number of cases as to justify the additional columns required.

Further details of the step-by-step procedure can be obtained from a study of the numerical examples.

V. EXAMPLES OF TRANSIENT-STABILITY PROBLEMS

In the previous sections, the concepts of calculating power-system stability are discussed in some detail. To illustrate the various salient features of stability calculations, and to make clear the exact procedure in a specific problem, two examples will be calculated in detail. All of the individual steps in the calculation are given, so that one inexperienced in this work can follow the problem readily. To facilitate understanding of the various factors involved in transient-stability calculations, references are given to the sections where the theory involved is discussed, and a considerable portion of the theory is reviewed. In addition to a thorough knowledge of the foregoing sections of this chapter, an understanding of machine characteristics, Chap. 6, is necessary in solving the problems.

The first example is a single-machine problem. This was chosen because it is the simplest case met in practice, and because in its solution the elements of a stability problem

can be illustrated with the least possibility of confusion. The single-machine problem is also useful when there are no intermediate loads, and losses can be neglected, since a two-machine problem can then be reduced to a single-machine problem, (Sec. 22). In the single-machine problem all resistances and line capacitances are neglected to simplify the calculations.

The two-machine example has been selected so that the sending end is the same for both problems. Both sending and receiving systems have finite inertia, and resistances are considered. This problem is important because it is the type most frequently calculated manually. Also, in using the general two-machine problem, all fundamental considerations affecting system stability in multi-machine systems can be illustrated.

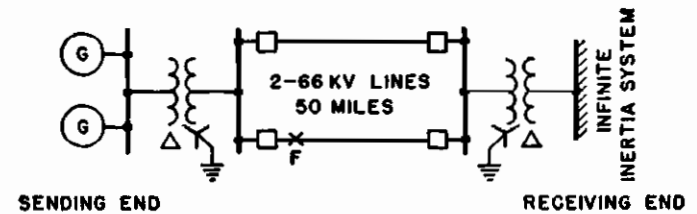

Fig. 31—Single-machine system assumed for study.

24. Description of Single-Machine System

The single-machine system selected for study, shown schematically in Fig. 31, has the following characteristics:

Transmission Lines:

Two circuits in parallel, 50 miles long, 10 foot flat spacing = 12.6 foot equivalent-delta spacing. Conductors are 250 000 circular mils, copper. Distance between line centers is 40 feet and the conductors are transposed. There are no ground wires. 50 000 kw at 100 percent power factor is delivered to the infinite receiver system. Normal voltage 66 kv.

Sending end:

Two 30 000-kva, three-phase, 60-cycle, waterwheel generators.
 Unsaturated synchronous reactance $x_d = 63.8$ percent
 Rated-current transient reactance $x_d' = 25.4$ percent
 (Chap. 6, Part XIII)
 Negative-sequence reactance $x_2 = 28.9$ percent
 Inertia constant (kw-sec/kva) $H = 3$
 Normal regulators and excitation system.

Transformers:

One 60 000-kva, three-phase, 60-cycle bank connected as shown in Fig. 31 at each end of the transmission lines.
 Reactance = 8 percent. Exciting current is neglected.

Receiving end:

Low-voltage side of receiver transformers connected to an infinite inertia system. Receiver low-voltage bus fixed at 95 percent of normal voltage.

25. Circuit Constants

This problem is calculated using the per-unit system. The values given in the illustrations are all in per unit. The base selected is the kva of the sending end, or 60 000 kva. Using the formulas in Chap. 10, Sec. 4 to 7,

$$\left. \begin{aligned} \text{Normal Current } \bar{I}_a &= \frac{60\,000}{\sqrt{3}(66)} = 525 \text{ amperes.} \\ \text{Normal Voltage } \bar{E}_a &= \frac{66}{\sqrt{3}} = 38.1 \text{ kv line-to-neutral.} \\ \text{Normal Impedance } \bar{Z}_a &= \frac{38.1 \times 10^3}{525} = 72.6 \text{ ohms.} \end{aligned} \right\} (39)$$

These values apply to the 66-kv portion of the system. If the above normal values are desired at any other point in the system, the transformer turns ratio should be used to determine the normal voltage at that point.

The first step in the calculation is to determine the impedances of the different elements of the system in per unit. These values are then put in the network and it is reduced to its simplest form.

The percent reactance of the generators on 60 000 kva is twice the values given, but since the two machines are in parallel, the reactance in the networks is halved so the above values can be used.

Using the methods of Chap. 3, X_1 and X_2 of each line equal 39.7 ohms. X_0 equals 138.2 ohms for one line, and 108.2 ohms for the two lines in parallel. The line reactances in per unit on 60 000 kva at 66 kv are:

Single Line:	
Positive- and negative-sequence reactance	$X_1, X_2 = 0.547$
Zero-sequence reactance	$X_0 = 1.90$
Two lines in parallel:	
Positive- and negative-sequence reactance	$X_1, X_2 = 0.274$
Zero-sequence reactance	$X_0 = 1.49$

A definite voltage is usually maintained at certain cardinal points in a system, and in this case the receiver low-voltage bus is maintained at 0.95 per-unit voltage. The sending-end generator terminal voltage is desired, so it is convenient to combine the portion of the network between the two buses into a single reactance. It is:

$$X_s = 0.434 \text{ per unit} \quad (40)$$

= 31.5 ohms.

The load delivered at the receiver low-voltage bus is 50 000 kw (0.833 per unit) at unity power factor. The current in the network is:

$$\bar{I} = \frac{0.833}{0.95} = 0.877 \text{ per unit} \quad (41)$$

= 460 amperes.

With this current flowing, the terminal voltage of the sending-end generator is:

$$\begin{aligned} E_s &= 0.95 + 0.877(j0.434) \\ &= 0.95 + j0.381 \\ &= 1.023 \epsilon^{j22^\circ} \text{ per unit} \\ &= 39.8 \epsilon^{j22^\circ} \text{ kv line-to-neutral} \end{aligned} \quad (42)$$

With the above quantities determined, all necessary information is available to compute the sending- and receiving-end power-circle diagrams. This is often done in practical problems in order to determine the initial operating conditions, but in the problem this information is given, so circle diagrams are not necessary.

26. Transient Stability Calculation

The most critical type of transient disturbance that receives consideration in stability studies is that arising from the application of a fault and the subsequent switching necessary to isolate the fault. In this problem a zero-impedance double line-to-ground fault is assumed to take place at the sending end of one of the transmission lines as shown in Fig. 31. Both ends of the faulted line are opened simultaneously to clear the fault. The problem is to determine the maximum permissible time between the inception of the fault and the opening of the circuit breakers for which stability can be maintained. The time thus determined is not the breaker operating time that would normally be used but the maximum operating time which could be allowed and still maintain stability. The ability of a system to withstand a double line-to-ground fault is often, but not invariably, taken as the criterion of system stability.

The first step is to calculate and plot power-angle diagrams (See Chap. 10; Chap. 13, Sec. 2) for three circuit conditions: (1) the initial condition immediately prior to inception of the fault, (2) the condition during the fault, and (3) the condition after the fault is isolated. Since in this case the receiver has infinite inertia, its angular position remains fixed and it is necessary only to calculate power-angle diagrams for the sending end. The equation relating sending-end power to the known circuit quantities (See Chap. 9) reduces to the following in this problem because losses have been neglected:

$$P_s = -\frac{\bar{E}'_{d-s} \bar{E}_{\infty-R}}{X} \cos(90^\circ + \theta) \quad (43)$$

in which θ is the angle between the internal voltages \bar{E}'_{d-s} and $\bar{E}_{\infty-R}$. Since the power-angle diagrams are to be determined for transient conditions, the voltage behind transient reactance E'_{d-s} must be used, and the value of X must be determined using generator transient reactance x'_d . The generator internal voltage, or voltage behind transient reactance is the vector sum of the terminal voltage of the machine and the voltage necessary to force the load current through the transient reactance.

$$\begin{aligned} E'_{d-s} &= 0.95 + j0.381 + 0.877(j0.254) \\ &= 1.12 \epsilon^{j32.2^\circ} \text{ per unit} \end{aligned} \quad (44)$$

Because of the times involved in transient disturbances, the internal voltage of the machine is generally considered constant (Sec. 30, and Chap. 6, Sec. 21), so this value of E'_{d-s} is used for the entire calculation.

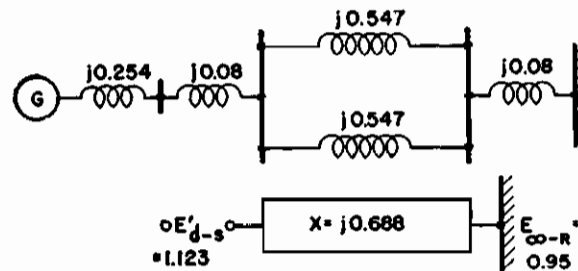

Fig. 32—Single-machine system. Network before the fault occurs.

Before the Fault—The network to be used in calculating the sending-end power before the fault is shown in Fig. 32. All necessary constants are known, so that,

$$P_s = -\frac{(1.12)(0.95)}{0.688} \cos(90 + \theta) = -1.55 \cos(90 + \theta) \text{ per unit} \quad (45)$$

During the Double Line-to-Ground Fault—The first step in determining the power-angle diagram during the fault is to reduce the negative- and zero-sequence networks to single equivalent reactances to be applied at the point of fault, (Sec. 10). The constants to be used in the negative- and zero-sequence networks are known, so these networks can be drawn readily. They are shown in Fig. 33 (a)

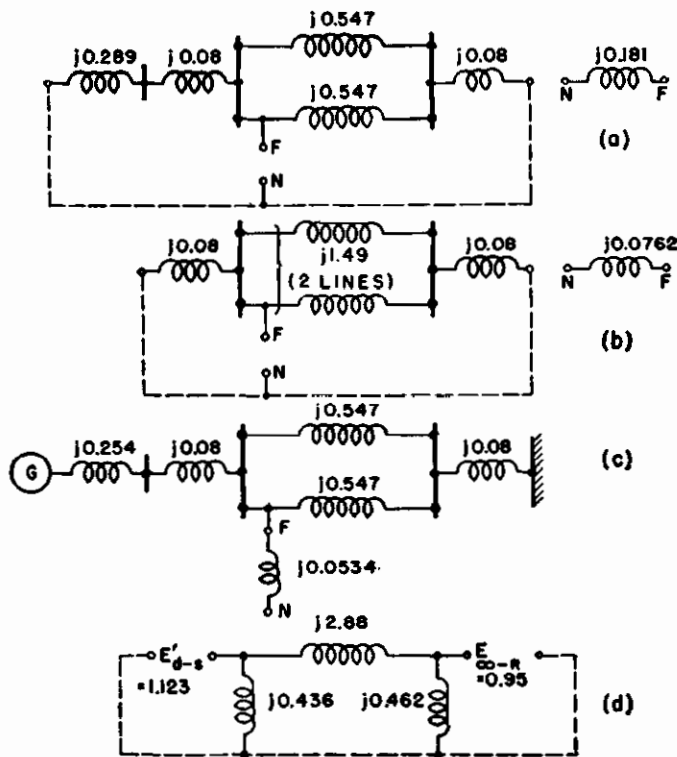

Fig. 33—Single-machine system. Networks for use during the double line-to-ground fault,
 (a)—Negative-sequence network.
 (b)—Zero-sequence network.
 (c)—Network during the fault)
 (d)—Network (c) reduced.

and (b), and to the right of each is the single equivalent reactance to which each network reduces. Since the fault is double line-to-ground, these two equivalent reactances must be paralleled (Chap. 2, Fig. 21) and connected at the point of fault. This is illustrated in Fig. 33 (c) which finally reduces to the network of Fig. 33 (d) by a simple star-delta conversion. With all losses neglected, the sending-end power is determined by Eq. (43). The shunt branches of Fig. 33 (d) need not be considered, as they only affect reactive power transfer. If maintained internal voltage had not been assumed and it was required to consider the demagnetizing effect of shunt loads, the shunt branches

would be considered. As the generator internal voltage or voltage back of transient reactance is assumed to remain constant, the same voltages calculated for the condition before the fault apply, and

$$P'_s = -\frac{(1.12)(0.95)}{2.88} \cos(90 + \theta) = -0.370 \cos(90 + \theta) \text{ per unit.} \quad (46)$$

After the Fault—When the faulted line section is isolated from the system, the network to be used for calcu-

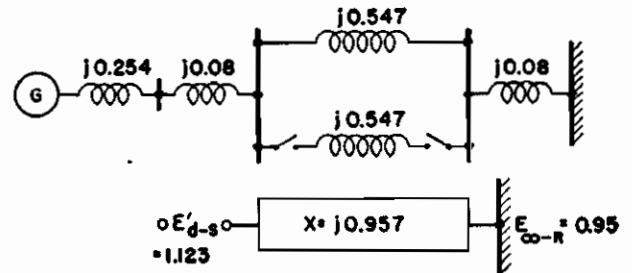

Fig. 34—Single-machine system. Network after the fault is isolated.

lating P_s'' is that shown in Fig. 34. Using the constants given, the sending-end power equation becomes:

$$P_s'' = -\frac{(1.12)(0.95)}{0.957} \cos(90 + \theta) = -1.11 \cos(90 + \theta) \text{ per unit.} \quad (47)$$

Power-Angle Diagrams and Limiting Angles—Equations (45), (46), and (47) are plotted in Fig. 35 as a function of θ , giving the power-angle diagrams of the single-machine system for the condition assumed. Inspection of the diagram or solving Eq. (45) for θ with $P_s = 0.833$ per unit shows that before the fault occurs the system is operating at an angle of 32.3 degrees. The maximum angle (critical angle of Sec. 4 and 6) to which the machine can swing, after the fault is isolated, without loss of stability is 131.6 degrees. This angle can be read from Fig. 35 or calculated by determining the value of θ between

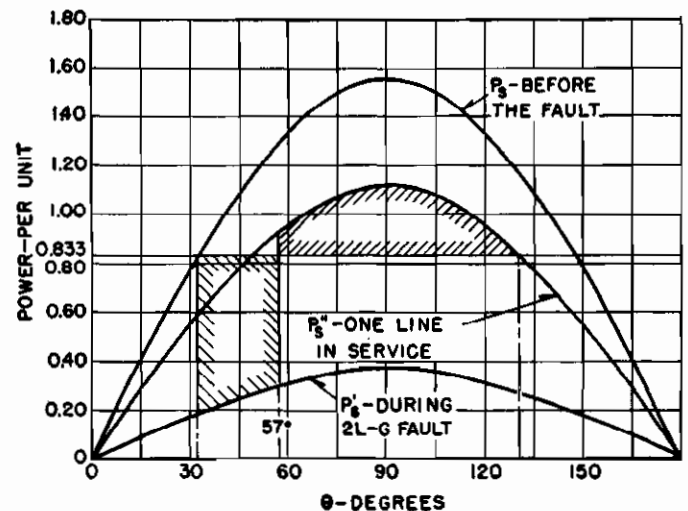

Fig. 35—Power-angle diagrams for single-machine system.

90° and 180° that will satisfy Eq. (47) with $P_s' = 0.833$ per unit. This is the maximum value that θ can reach without the system becoming unstable. If the angle θ exceeds 131.6°, then the mechanical input to the sending-end generator exceeds its electrical output (see Fig. 35), and the generator pulls out of synchronism. By the equal-area method described in Sec. 6, an angle of approximately 57 degrees is selected as the maximum angle at which the fault can be isolated if stability is to be maintained.

Angle-Time or Swing Curves—To determine the time of fault isolation corresponding to 57 degrees, θ is determined as a function of time by a step-by-step method. The method is described in detail in Sec. 23, and a convenient means of calculating is to use the tabular form illustrated by Table 2. Such a calculation is carried out in Table 3, using this form. The first part of Table 3 assumes that the fault is not isolated, and the rapid increase in θ indicates how fast the system becomes unstable under these conditions. Note that the low inertia constant ($H=3$ kw-sec/kva) of the generators permits them to change angular position rapidly, so that relatively small time intervals, 0.05 seconds, are chosen for the calculation.

As previously explained, the velocity is assumed constant over each period, but the acceleration is assumed constant from the middle of one period to the middle of the next. This is done to minimize cumulative errors. Column 6 shows how this is done.

The second part of the tabulation assumes that the fault is isolated in 0.15 seconds, since in this time θ has increased to 57.2 degrees which matches closely the 57 degrees chosen as the maximum switching angle to maintain stability in Fig. 35. The terms -0.15 and $+0.15$ seconds in column 1 indicate the increments of time before and after the breakers open. Note the changes in columns 6, 7, and 9 for the -0.15 second time. The calculation indicates that stability is maintained, since θ reaches a maximum value less than the critical angle of 131.6 degrees. The calculation is carried far enough to show that θ begins to return to the new operating point.

The angle-time or swing curves resulting from the step-by-step calculation are plotted in Fig. 36. Curves *A* and *B* are the graphic plot of the calculations carried out in Table 3. They show more clearly that stability will be lost quickly if the fault is not isolated and that stability is just maintained if the total fault clearing time is not greater than 0.15 seconds. Curves *C* and *D* have also been calculated by the step-by-step method, and show that stability is lost for fault clearing times slightly longer than 0.15 seconds.

27. Assumptions Made in Solving Two-Machine Problems

The two-machine problem given below is an example of the manner in which this problem can be solved by

TABLE 3—STEP-BY-STEP CALCULATION OF ANGLE-TIME CURVES FOR SINGLE-MACHINE SYSTEM

$H=3$ $k = \frac{180 \times 60}{3 \times 1} = 3600$										
(1)	(2)	(3)	(4)	(5)	(6)	(7)	(8)	(9)	(10)	(11)
Time in Sec at Beginning of Interval	Angle θ at Beginning of Interval	Electrical Power Output, Per Unit	ΔP , Mechanical Input Minus Electrical Output	Acceleration, Degrees per Sec per Sec	Acceleration Time Increment, Seconds	Velocity Change, Degrees per Second	Velocity, Degrees per Second	Angle-Time Increment	Angular Change, Degrees	θ Final Angle, Degrees
—	—	—	0.833 - (3)	(4) $\times k$	—	(5) \times (6)	(7) + (8) _{n-1}	—	(8) \times (9)	(10) + (2)
0.0	32.3	0.199	0.634	2285	0.025	57.0	57.0	0.05	2.85	35.2
0.05	35.2	0.213	0.620	2230	0.05	111.5	168.5	0.05	8.43	43.6
0.10	43.6	0.255	0.578	2080	0.05	104.0	272.5	0.05	13.6	57.2
0.15	57.2	0.312	0.521	1880	0.05	94.0	366.5	0.05	18.3	75.5
0.20	75.5	0.358	0.475	1710	0.05	85.5	452.0	0.05	22.6	98.1
0.25	98.1	0.367	0.466	1680	0.05	84.0	536.0	0.05	26.8	124.9
0.30	124.9	0.303	0.530	1910	0.05	95.5	631.5	0.05	31.6	166.5
0.35	166.5									
Fault Isolated in 0.15 Seconds										
-0.15	57.2	0.312	0.521	1880	0.025	47.0	320			
+0.15	57.2	0.936	-0.103	-372	0.025	-9.3	311	0.05	15.5	72.7
0.20	72.7	1.063	-0.230	-829	0.05	-41.5	269	0.05	13.5	86.2
0.25	86.2	1.112	-0.279	-1000	0.05	-50.0	219	0.05	11.0	97.2
0.30	97.2	1.105	-0.272	-977	0.05	-48.9	170	0.05	8.5	105.7
0.35	105.7	1.071	-0.238	-858	0.05	-42.8	127	0.05	6.4	112.1
0.40	112.1	1.032	-0.199	-714	0.05	-35.7	91	0.05	4.6	116.7
0.45	116.7	0.996	-0.163	-588	0.05	-29.4	62	0.05	3.1	119.8
0.50	119.8	0.963	-0.130	-460	0.05	-23.4	38	0.05	2.0	120.8
0.55	120.8	0.958	-0.125	-450	0.05	-22.5	16	0.05	0.8	121.6
0.60	121.6	0.950	-0.117	-420	0.05	-21.0	-5	0.05	-0.2	121.4
0.65	121.4	0.950	-0.117	-420	0.05	-21.0	-26	0.05	-1.3	120.1

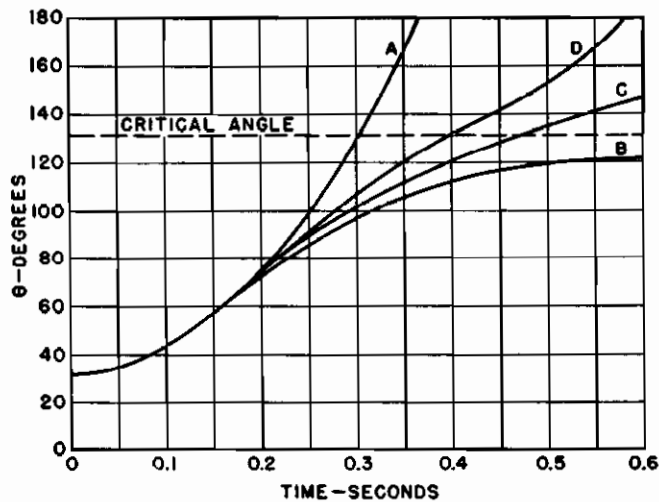

Fig. 36—Angle-time curves for single-machine system.

- A—Fault not cleared.
 B—Fault isolated in 0.15 sec.
 C—Fault isolated in 0.16 sec.
 D—Fault isolated in 0.17 sec.

calculation. A number of simplifying assumptions are made, most of which are conservative.

The common assumptions are listed, together with references from which their effect can be determined.

1. Impedance of the load is constant (Sec. 9).
2. Effect of saliency is generally neglected (Sec. 15).
3. Negative-sequence loss varies as I_2^2 for all machines (Chap. 6, Part XIII). This assumption is inherent in the method of symmetrical components (Sec. 10).
4. Rated-current transient reactance is normally used (Chap. 6, Part XIII).
5. The losses in generators are sometimes neglected. This is permissible when the output of the machine during the fault is large compared with its losses. Typical generator resistances are given in Chap. 6. The loss due to the unidirectional component of short-circuit current is discussed in Chap. 6.
6. The internal voltage or voltage behind transient reactance is assumed to remain constant during a transient disturbance (Chap. 6, Sec. 22).
7. The effect of negative-sequence torque is generally neglected (Sec. 10).

Almost all of the above assumptions are conservative, and the net effect is conservative. More accurate calculations can be made by referring to the references given, but this is not usually done because more margin than is obtained by these assumptions is necessary for safe operation of a system from the standpoint of transient stability.

Generally, the first step in the calculation of a two-machine problem is to draw the sending-end and receiving-end circle diagrams, which would be used to determine the operating conditions of a system at the time of a fault (Chap. 10, Sec. 21). In this problem this information is given.

28. Description of Two-Machine System

The two-machine system assumed for study is illustrated in Fig. 37. The sending end is the same as in the single-

machine problem. Transformer resistance is included, but generator resistances are not. Including resistance, the transformer impedance becomes $1+j8$ percent. The line data in ohms using the methods of Chap. 3 are:

Single line:

Positive- and negative-sequence impedance	$Z_1, Z_2 = 12.9 + j39.7$
Zero-sequence impedance	$Z_0 = 27.2 + j138.2$

Two lines in parallel:

Positive- and negative-sequence impedance	$Z_1, Z_2 = 6.43 + j19.9$
Zero-sequence impedance	$Z_0 = 20.7 + j108.2$

The receiving-end data are:

Generators:

Two 62 500-kva, three-phase, 60-cycle turbine generators	
Unsaturated synchronous reactance	$x_d = 125$ percent
Rated-current transient reactance	$x_d' = 15.6$ percent
Negative-sequence reactance	$x_2 = 9.8$ percent
Inertia constant (kw-sec/kva)	$H = 5$

Shunt load:

115 000 kw at 85 percent power factor located at receiving-end low-tension bus. Load is represented by a constant impedance.

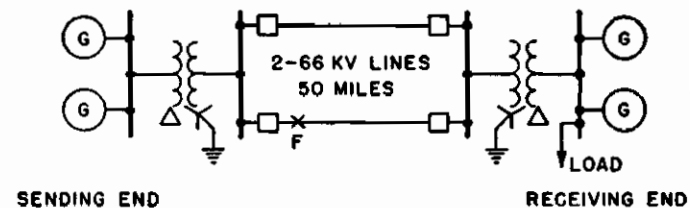

Fig. 37—Two-machine system assumed for study.

29. Circuit Constants

The two-machine problem is also calculated using the per-unit system. The kva base is optional, so for simplicity 60 000-kva base is again used.

The circuit constants in per unit on 60 000 kva are:

Transmission lines:

Single line:

Positive- and negative-sequence impedance	$Z_1, Z_2 = 0.177 + j0.543$
Zero-sequence impedance	$Z_0 = 0.373 + j1.90$

Two lines in parallel:

Positive- and negative-sequence impedance	$Z_1, Z_2 = 0.0883 + j0.274$
Zero-sequence impedance	$Z_0 = 0.284 + j1.49$

Receiving End:

Each Generator:

Conventional synchronous reactance	$x_d = 1.20$
Rated-current transient reactance	$x_d' = 0.15$
Negative-sequence reactance	$x_2 = 0.094$
Inertia constant (kw-sec/kva)	$H = 5$

Shunt load:

The shunt load is 1.92 per unit at 0.85 lagging power factor, or $1.92 + j1.19$ per unit.

Since the machines are in parallel, the above values must be divided by two before insertion in the sequence networks.

The capacitance of the two 50-mile transmission lines is neglected in this problem. This is justified on the basis of calculations that show the line capacitive reactance to be nearly equal in magnitude to the transformer magnetizing reactance, and the latter has also been neglected. Consideration of line capacitive reactance and transformer magnetizing reactance would add in no way to the problem's effectiveness in illustrating a typical stability calculation, nor would it add to the generality of the networks involved, since the load introduces a shunt branch. If it is necessary to include these effects, Chap. 3 gives line constants, which may be converted to general circuit (*ABCD*) constants by Table 9, Chap. 10 or by Chap. 9, Sec. 6. The equivalent π form is given in Chap. 9, Sec. 6. The appendix gives equivalent circuits for transformers, which can be introduced into the circuit.

As in the single-machine problem, voltage is considered to be maintained at the receiving low-tension bus. The receiving-end maintained bus voltage is 36.2 kv line-to-neutral (95 percent of normal). With voltage maintained at this point, it is again convenient to combine the network between the low-voltage buses into a single set of circuit constants. These quantities are tabulated in the first four columns of Table 4 in terms of the familiar *ABCD* constants (See Chap. 10), which are used in this problem to facilitate the handling of the network involving shunt branches. The *ABCD* constants for one line plus the transformers, and for two lines in parallel plus the transformers, can be written immediately without further calculation by using the quantities given above and Network Number 1 of the tabulated formulas for *ABCD* constants given in Chap. 10. These two sets of constants are listed in Table 4, Cols. (1) and (2). Since the load also forms part of the network between the points of maintained voltage, it will be combined with the constants of Cols. (1) and (2) to give those listed in Cols. (3) and (4), respectively. This is accomplished by using Network Number 10, Table 9, Chap. 10.

The load at the receiver low-tension bus is 1.92 per unit at 85 percent power factor, or $1.92 + j1.19$ per unit. Part of the total kva is supplied by the sending-end generators and part by the receiving-end units. For this problem, it is assumed that the sending-end station is delivering 50 000 kw (0.833 per unit) at unity power factor to the load. This dictates that the receiving-end station is delivering $1.08 + j1.19$ per unit to the load, or 1.08 per unit real power at 67.4 percent power factor. With 0.833 per unit real power coming to the load through the network, the current drawn through the network is

$$\bar{I}_s = \frac{0.833}{0.95} = 0.877 \text{ per unit at 100 percent power factor} \quad (48)$$

Note that this expression is identical to Eq. (41). With the above current flowing, the sending-end low tension bus voltage is

$$\begin{aligned} E_s &= 0.95 + 0.877(0.108 + j0.434) \\ &= 1.045 + j0.381 \text{ per unit} \\ &= 1.11 \epsilon^{j20^\circ} \text{ per unit} \\ &= 42.5 \epsilon^{j20^\circ} \text{ kv line-to-neutral.} \end{aligned} \quad (49)$$

The current flowing to the load from the receiving-end machines, when they are delivering $1.08 + j1.19$ per unit power (1.605 per unit power at 67.4 percent power factor) is

$$\begin{aligned} \bar{I}_R &= \frac{1.605}{0.95} = 1.69 \text{ per unit at 67.4 percent power factor.} \\ I_R &= 1.14 - j1.25 \text{ per unit} \\ &= 599 - j658 \text{ amperes.} \end{aligned} \quad (50)$$

30. Transient-Stability Calculation

In the single-machine problem the most severe type of transient disturbance was considered, namely, the application of a fault and its subsequent isolation. The same disturbance is considered in the present problem, and the same zero-impedance double line-to-ground fault located at the sending end of one transmission line is used. This is shown in Fig. 37. The circuit breakers are assumed to open simultaneously to isolate the faulted line, and again maximum permissible time between fault inception and breaker clearing to maintain stability is to be determined. Here again it becomes apparent that prompt switching is imperative if the assumed load is to be carried.

Before plotting power-angle diagrams for the sending and receiving ends for the three circuit conditions, (1) before, (2) during, and (3) after the fault, it is necessary to calculate the generator internal voltages using the known terminal voltages, E_s and E_R and the generator rated-current transient reactances (x_d'). The sending-end internal voltage is:

$$\begin{aligned} E'_{d-s} &= 1.045 + j0.381 + 0.877(j0.254) \\ &= 1.045 + j0.604 \text{ per unit} \\ &= 1.21 \epsilon^{j30^\circ} \text{ per unit} \\ &= 46.2 \epsilon^{j30^\circ} \text{ kv line-to-neutral.} \end{aligned} \quad (51)$$

The receiving-end voltage behind transient reactance, remembering that \bar{E}_R is 0.95 per unit volts, is

$$\begin{aligned} E'_{d-R} &= 0.95 + (1.14 - j1.25)(j0.075) \\ &= 1.044 + j0.0855 \text{ per unit} \\ &= 1.048 \epsilon^{j4.7^\circ} \text{ per unit} \\ &= 40 \epsilon^{j4.7^\circ} \text{ kv line-to-neutral.} \end{aligned} \quad (52)$$

Before the Fault—The network for use in calculating the sending- and receiving-end power is shown in Fig. 38. Since the equivalent circuits of the generators consist of a series impedance, their *ABCD* constants can be written down without calculation. These are listed in Col. (5) and (6) of Table 4. Now using Network Number 16 from the tabulation of *ABCD*-constants formulas of Chap. 10, the *ABCD* constants for the entire system can be determined. The results are given in Table 4, Col. (7). To illustrate the

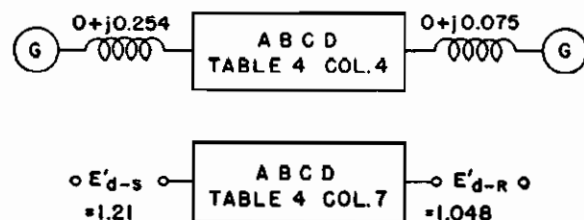

Fig. 38—Two-machine system. Network before the fault occurs.

method, the B constant is calculated below. Subscript 1 denotes the receiving-end generator; 2 denotes two parallel lines with transformers and load; and 3 the sending-end generators.

$$\begin{aligned}
 B &= A_3(B_1A_2 + D_1B_2) + B_3(B_1C_2 + D_1D_2) \\
 &= (1+j0)[(0+j0.075)(1.799+j0.774) + (1+j0)(0.109 \\
 &\quad +j0.434)] + (0+j0.254)[(0+j0.075)(2.11-j1.31) \\
 &\quad + (1+j0)(1+j0)] \\
 &= 0.011 + j0.847 = 0.847 e^{j89.2^\circ}
 \end{aligned}$$

The real parts of equations 85 and 86, Chap. 9 can be expressed in the form:

$$P_S = \frac{\bar{E}_S \bar{D}}{\bar{B}} \cos(\beta - \delta) - \frac{\bar{E}_R \bar{E}_S}{\bar{B}} \cos(\beta + \theta) \quad (53)$$

$$\text{and } P_R = -\bar{E}_R \frac{\bar{A}}{\bar{B}} \cos(\beta - \alpha) + \frac{\bar{E}_R \bar{E}_S}{\bar{B}} \cos(\beta - \theta). \quad (54)$$

Where P_S and P_R are the sending- and receiving-end power, \bar{E}_S and \bar{E}_R are their respective internal voltages from equations (51) and (52), and α , β , and δ are the vector angles of the A , B , and D constants, respectively. Positive direction of power flow is out of the sending-end generators and into the receiving-end generators.

P_S and P_R for the condition before the fault can now be calculated.

$$\begin{aligned}
 P_S &= (1.21)^2 \frac{1.110}{0.847} \cos(89.2^\circ - 8.2^\circ) \\
 &\quad - \frac{(1.21)(1.048)}{0.847} \cos(89.2^\circ + \theta) \\
 &= 0.300 - 1.50 \cos(89.2^\circ + \theta) \text{ per unit.} \quad (55)
 \end{aligned}$$

$$\begin{aligned}
 P_R &= -(1.048)^2 \frac{2.50}{0.847} \cos(89.2^\circ - 31.5^\circ) \\
 &\quad + \frac{(1.21)(1.048)}{0.847} \cos(89.2^\circ - \theta) \\
 &= -1.73 + 1.50 \cos(89.2^\circ - \theta) \text{ per unit.} \quad (56)
 \end{aligned}$$

During the Fault—As in the single-machine system, the negative- and zero-sequence networks must be determined, reduced to single impedances, and applied at the point of fault. Both of these networks can be readily constructed as all of the circuit constants are given in Sec. 29. The negative- and zero-sequence networks are shown in Fig. 39 (a) and (b), and at the right of each the single equivalent impedance that represents the network is shown. Because the assumed fault is double line-to-ground, the two single impedances representing the negative- and zero-sequence networks must be paralleled before they are applied to the point of fault (Chap. 2, Fig. 21). The complete network for use during the fault is shown in Fig. 39 (c), which includes this resulting shunt impedance.

It is now necessary to reduce the network of Fig. 39 (c) to one set of circuit constants before the power equations can be solved. To do this involves a rather general usage of $ABCD$ constants and the necessary steps will be individually traced. The first step is to obtain the network of Fig. 39 (d), which is readily accomplished. The sum of the sending-end generator and transformer impedances form the left-hand branch, the receiving-end generator impedance alone forms the right-hand branch, and the shunt

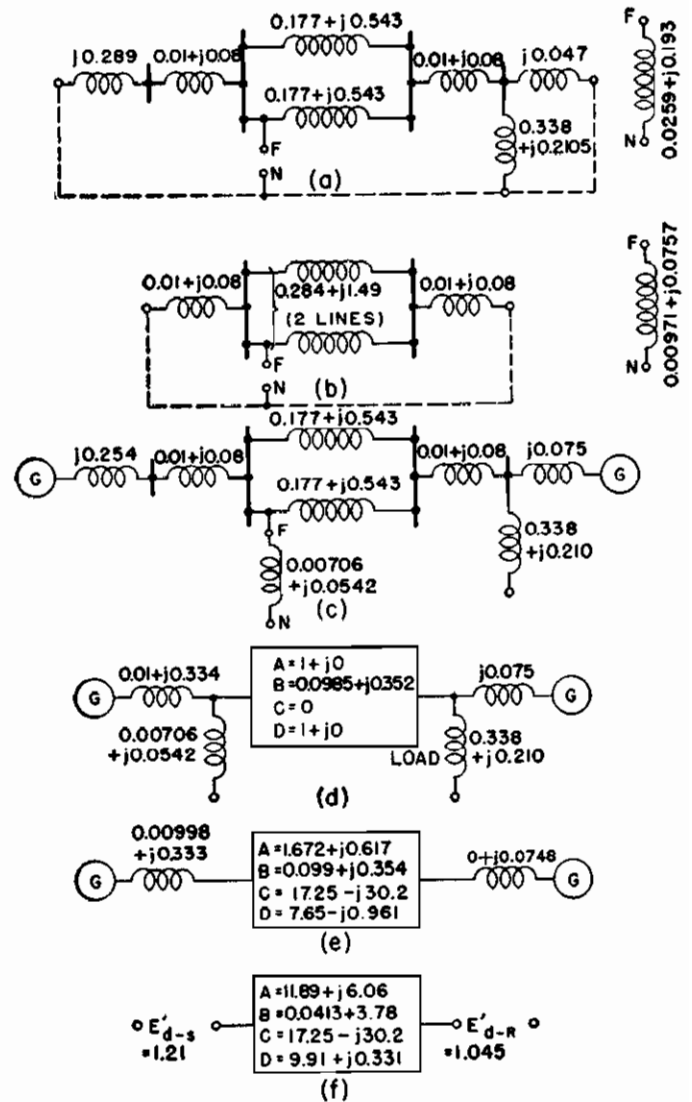

Fig. 39—Two-machine system. Networks for use during the double line-to-ground fault.

- (a)—Negative-sequence network.
- (b)—Zero-sequence network.
- (c)—Complete network during the fault.
- (d)—First reduction of complete network.
- (e)—Second reduction of complete network.
- (f)—Final reduced network during the fault.

branches consist of the impedances representing the load and the fault, both of which are taken directly from Fig. 39 (c). The center unit is found by paralleling the two transmission lines and adding the receiving-end transformer impedance. The latter renders one series impedance for which the $ABCD$ constants can be written without calculation. The network of Fig. 39 (d) is thus complete, and the next step is to simplify this network to that shown in Fig. 39 (e). This step combines the two shunt branches into the general circuit constants and can be performed by using Network Number 12 of the table of formulas for $ABCD$ constants given in Chap. 10. Before using Network Number 12, the two shunt branches must be converted to admittances by taking the reciprocal of the known

TABLE 4—CIRCUIT CONSTANTS FOR TWO-MACHINE SYSTEM

Constant	(1) One Line with Transformers	(2) Two Lines with Transformers	(3) One Line with Transformers and Load	(4) Two Lines with Transformers and Load	(5) Sending-End Generators	(6) Receiving-End Generators	(7) System Before The Fault	(8) System During The Fault	(9) System After The Fault
A	$1+j0$ ϵ^{j0}	$1+j0$ ϵ^{j0}	$2.34+j1.24$ $2.66\epsilon^{j27.7}$	$1.799+j0.774$ $1.955\epsilon^{j23.3}$	$1+j0$ ϵ^{j0}	$1+j0$ ϵ^{j0}	$2.13+j1.307$ $2.50\epsilon^{j31.5}$	$11.89+j6.06$ $13.34\epsilon^{j27.0}$	$2.67+j1.771$ $3.21\epsilon^{j33.5}$
B	$0.197+j0.708$ $0.735\epsilon^{j74.4}$	$0.109+j0.434$ $0.448\epsilon^{j70.9}$	$0.197+j0.708$ $0.735\epsilon^{j74.4}$	$0.109+j0.434$ $0.448\epsilon^{j70.9}$	$0+j0.254$ $0.254\epsilon^{j90}$	$0+j0.075$ $0.075\epsilon^{j90}$	$0.011+j0.847$ $0.847\epsilon^{j89.2}$	$0.0413+j3.78$ $3.79\epsilon^{j89.3}$	$0.064+j1.161$ $1.162\epsilon^{j88.8}$
C	0	0	$2.11-j1.31$ $2.48\epsilon^{-j31.8}$	$2.11-j1.31$ $2.48\epsilon^{-j31.8}$	0	0	$2.11-j1.31$ $2.48\epsilon^{-j31.8}$	$17.25-j30.2$ $34.7\epsilon^{-j60.2}$	$2.11-j1.31$ $2.48\epsilon^{-j31.8}$
D	$1+j0$ ϵ^{j0}	$1+j0$ ϵ^{j0}	$1+j0$ ϵ^{j0}	$1+j0$ ϵ^{j0}	$1+j0$ ϵ^{j0}	$1+j0$ ϵ^{j0}	$1.098+j0.1583$ $1.110\epsilon^{j8.2}$	$9.91+j0.331$ $9.91\epsilon^{j1.9}$	$1.098+j0.1583$ $1.110\epsilon^{j8.2}$

impedances. The fault and load branches expressed as admittances are, respectively:

$$Y_s = \frac{1}{0.00706 + j0.0542} = 2.36 - j18.14 \text{ per unit} \quad (57)$$

and

$$Y_R = \frac{1}{0.340 + j0.211} = 2.11 - j1.31 \text{ per unit.} \quad (58)$$

Now the network of Fig. 39 (e) is complete, and it remains only to combine the two series impedances with the central set of circuit constants, and Fig. 39 (f), the final reduction, is determined. This simplification is performed by using Network Number 16 from the table in Chap. 10 referred to above. The sample calculation of the B constant, for the network used before the fault, will illustrate the method. Col. (8) of Table 4 gives the final circuit constants for use during the fault. Using these circuit constants and the previously calculated internal voltages, which we assume to remain constant, all quantities are available for calculation of P_s' and P_R' , the sending- and receiving-end power during the fault. Substituting in Eqs. (53) and (54),

$$P_s' = (1.21)^2 \frac{9.91}{3.79} \cos(89.3^\circ - 1.9^\circ) - \frac{(1.21)(1.048)}{3.79} \cos(89.3^\circ + \theta) = 0.1753 - 0.335 \cos(89.3^\circ + \theta) \text{ per unit.} \quad (59)$$

$$P_R' = -(1.048)^2 \frac{13.34}{3.79} \cos(89.3^\circ - 27.0^\circ) + \frac{(1.21)(1.048)}{3.79} \cos(89.3^\circ - \theta) = -1.797 + 0.335 \cos(89.3^\circ - \theta) \text{ per unit.} \quad (60)$$

After the Fault—The network for use in calculating sending- and receiving-end power after the double line-to-ground fault has been isolated, is shown in Fig. 40. Except for the fact that one transmission line only is in service, the network is identical to that which applied before the fault occurred. Exactly the same procedure is followed in arriving at the final set of circuit constants, and these constants are listed in Col. (9) of Table 4. The power equations after the fault become:

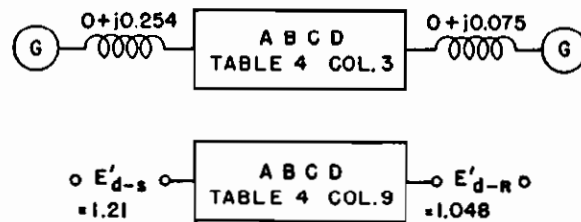

Fig. 40—Two-machine system. Network after the fault is isolated.

$$P_s'' = (1.21)^2 \frac{1.110}{1.162} \cos(86.8^\circ - 8.2^\circ) - \frac{(1.21)(1.048)}{1.162} \cos(86.8^\circ + \theta) = 0.276 - 1.09 \cos(86.8^\circ + \theta) \text{ per unit.} \quad (61)$$

$$P_R'' = -(1.048)^2 \frac{3.21}{1.162} \cos(86.8^\circ - 33.5^\circ) + \frac{(1.21)(1.048)}{1.162} \cos(86.8^\circ - \theta) = -1.726 + 1.092 \cos(86.8^\circ - \theta) \text{ per unit.} \quad (62)$$

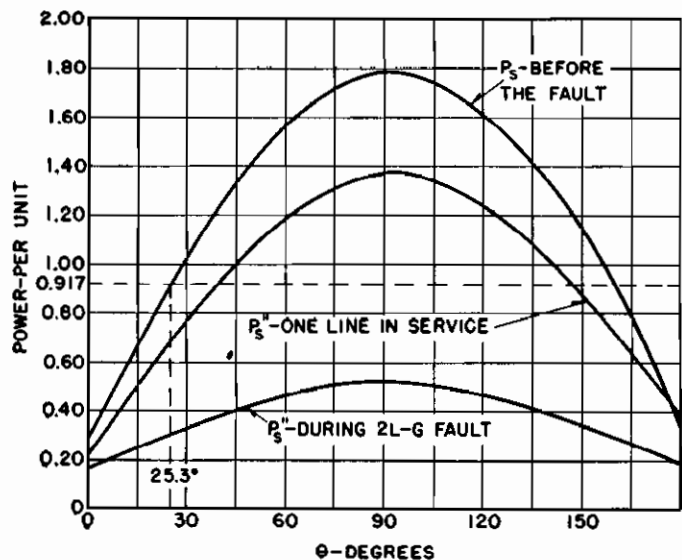

Fig. 41—Sending-end power-angle diagrams for two-machine problem.

Power-Angle Diagrams—Eqs. (55), (59), and (61) are plotted in Fig. 41 as a function of θ , giving the sending-end power-angle diagrams for the conditions assumed. The receiving-end diagrams are plotted in a similar manner from Eqs. (56), (60), and (62). These are shown in Fig. 42. The solution of the receiving-end power equations to obtain Fig. 42 renders negative values, because positive direction of power flow was chosen as being into the receiving-end generators. In Fig. 42 the per-unit power scale is plotted as positive, because this is believed to be less confusing than negative values. This is permissible if the change in sign is recognized when performing the step-by-step solution for angle-time curves.

Note that in Fig. 41 the sending-end input is indicated by the horizontal line as 0.917 per-unit. This figure is the sum of the 0.833 per-unit power delivered to the load plus the line and transformer losses. Since line capacitance is neglected (Sec. 29) the total volt-ampere consumption in the system is,

$$\begin{aligned} I^2Z &= (0.877)^2(0.109 + j0.434) \\ &= 0.0838 + j0.334 \text{ per unit} \\ &= 5000 + j20\,200 \text{ kva.} \end{aligned}$$

The in-phase portion, or loss, is 0.0838 per unit, so that the total sending-end power is $0.833 + 0.0838 = 0.917$ per unit. The receiving-end power-angle diagrams of Fig. 42 show the receiving-end input to be 1.083 per unit, which is the same figure as the power delivered to the load from the receiving bus, since there are no losses present in that end of the network.

The initial operating angle is $\theta = 25.3$ degrees as indicated in Figs. 41 and 42. This is the angular difference in

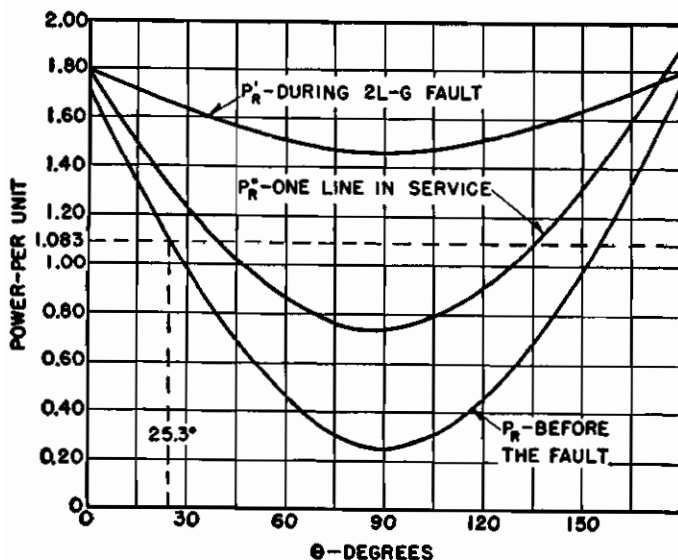

Fig. 42—Receiving-end power-angle diagrams for two-machine problem.

electrical degrees between the rotors, or internal voltages, of the sending- and receiving-end machines before the fault occurs. This figure of 25.3 degrees can be readily checked by taking the difference in angle of the internal voltages expressed in Eqs. (51) and (52). This serves

as a quick check on the calculation of the power-angle diagrams for the condition before the fault.

In the single-machine problem it was possible to estimate the maximum angle of fault clearing by simply balancing positive and negative areas on the power-angle diagram (See Sec. 26). This was possible because the movement of only one machine rotor had to be followed. In the present case, this equal-area method can not be applied because stability or instability is determined by the relative angular position of two machines. The maximum rotor-displacement angle before fault isolation is not determined from the power-angle diagrams, but will be found as a part of the calculation of angle-time curves.

Angle-Time or Swing Curves—The angle-time curves, which relate time to angular displacement, are most conveniently determined by the step-by-step integration method described in Sec. 23. The calculation is similar to that carried out for the single-machine system except that the angular swing of both sending and receiving machines must be traced during each time interval.

The best description of the actual procedure is had by referring to Table 5 in which the angle-time or swing curves are calculated. The form used is identical, for each machine, to that of Table 3, so that altogether it is similar to two single-machine system calculations. The calculations for one time interval must be made for both machines before proceeding to the next interval. This is true because the one quantity relating the angular position of the two machines, θ , is found by taking the difference in angle of the two machines at the end of each interval, and in order to find the electrical output for each machine in the succeeding interval, this value of θ is applied to each set of power-angle diagrams or calculated from the corresponding sending- and receiving-end power equations. To make this clear, refer to the first time interval in Table 5. The initial position of each rotor, with respect to the receiving-end low-tension bus voltage, is given in Cols. (2) and (12). The initial value of θ is the difference between the rotor angles, Col. (2) minus Col. (12), or 25.3 degrees as previously determined. Using this value of θ , the electrical output from each machine is determined, and the calculation proceeds to find the angle of each rotor at the end of the first interval. These figures are tabulated in Cols. (11) and (21), and subtracting (21) from (11) gives the new θ , Col. (23), to be used in the next time interval. This new θ is then used in the power-angle diagrams, or the corresponding sending- and receiving-end power equations, to obtain the electrical output from each machine in the second interval. The computation is now carried on to find θ at the end of the second interval, etc.

The first part of Table 5 assumes that the fault is not isolated, and illustrates by the continued increase of θ that the system becomes unstable under this condition. Time intervals of 0.05 second are used because of the relatively rapid swing of the sending-end machines. A comparison of Cols. (11) and (21) points out that the receiver machines swing much slower than the sending-end machines. This is caused by the relatively larger inertia constant and kva rating of the receiver generators, resulting in a much smaller acceleration [Col. (15) compared to (5)]. The second part of Table 5 assumes that the fault is isolated in

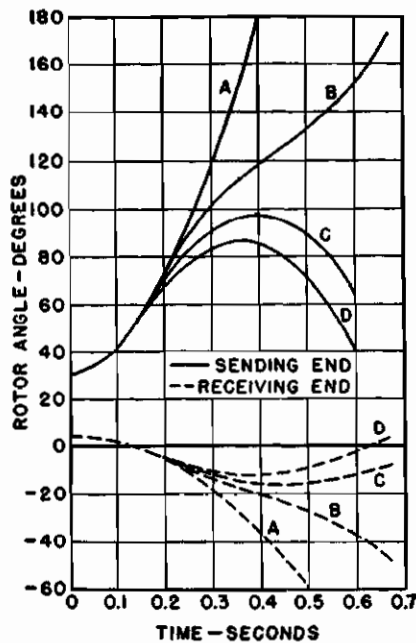

Fig. 43—Angle-time curves for each machine. Two-machine system.

- A—Fault not cleared.
- B—Fault isolated in 0.20 sec.
- C—Fault isolated in 0.17 sec.
- D—Fault isolated in 0.15 sec.

0.15 seconds. Col. (23) shows that θ reaches a maximum of 98.7 degrees and then starts to return toward a new stable operating point. Figures 41 and 42 indicate that the new operating point is at an angle $\theta = 39$ degrees.

The results of the calculations performed in Table 5 are given in Figs. 43 and 44. The swing of each rotor with respect to the fixed reference is shown in Fig. 43. Curves

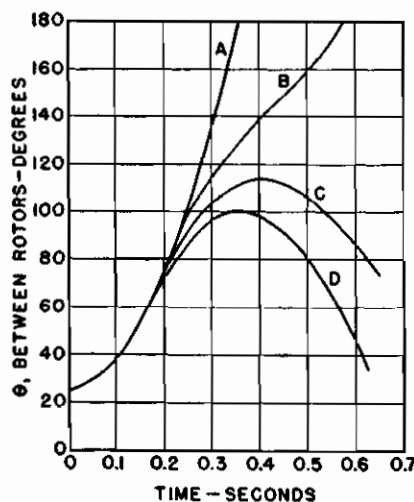

Fig. 44—Angle-time curves for two-machine system showing difference in rotor angle between sending and receiving machines.

- A—Fault not cleared.
- B—Fault isolated in 0.20 sec.
- C—Fault isolated in 0.17 sec.
- D—Fault isolated in 0.15 sec.

A and D of Fig. 43 represent a plot of the figures in Cols. (11) and (21) of Table 5. Curves B and C of Fig. 43 represent similar step-by-step calculations for longer times of fault isolation. By following the trend of the sending- and receiving-end angle-time curves for a given fault-clearing time, the loss or maintenance of stability can be seen. If the phase angle difference of the two machines continues to increase after fault isolation, instability results, but if the two machines tend to move back together during this time, the system is stable. It is possible for instability to occur on the second overswing, which is an exception to the above statement. This phenomenon is relatively rare but should be remembered in multi-machine problems, particularly where one or two machines are swinging very fast with respect to the other sources involved. Figure 43 indicates that for fault clearing times of 0.15 and 0.17 seconds stability is maintained, and for 0.20 seconds instability results.

In the two-machine system a more convenient way of plotting swing curves is that shown in Fig. 44, in which the difference in angular displacement, θ , is used rather than the individual position of each machine. Referring to Fig. 44, it is plain that the system is stable for fault isolation times of 0.15 and 0.17 seconds, and that stability is quickly lost if the fault duration is 0.20 seconds. Curves A and D of Fig. 44 are plotted from Col. (23) in Table 5.

VI. SHORT-CUT METHODS OF CALCULATION —TWO-MACHINE SYSTEM

Perhaps the most usual reason for making a stability calculation on this type of system is to determine how fast relays and circuit breakers must be made to operate if stability is to be maintained after a fault occurs. R. D. Evans and W. A. Lewis presented a group of curves,¹⁶ calculated for a two-machine system having the usual circuit elements, which permit the quick estimation of permissible fault durations for various types of faults.

31. Assumed System

For a complete and accurate calculation on a particular system it is necessary to consider all the various factors discussed in Part V. For determining approximate relay and circuit-breaker time, results of sufficient accuracy can be obtained, except under extreme or unusual conditions. The assumed system upon which the calculation of the general curves is based, is shown in Fig. 45, and the

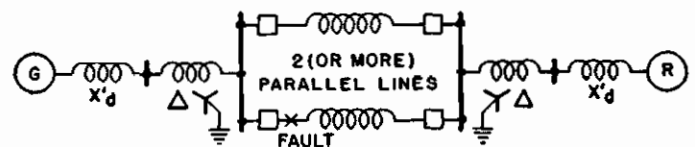

Fig. 45—System conditions assumed for study:

Symmetrical system, high tension bus at each end; line capacitance and I^2R losses neglected; transformer neutrals solidly grounded; quick response excitation (constant internal voltage); no damper windings; frequency = 60 cycles; load = 100 percent at instant of fault inception; faults located at most severe point on high-tension lines; average short-circuit losses.

simplifying assumptions made for the study are included at the bottom of the figure.

The results of the stability calculations are given in the four groups of curves, Figs. 46–49. These curves give directly the results for a system with the smallest inertia which may be expected, corresponding to water-wheel generators at both ends of the system. In the more usual case, the receiver machine will have a larger inertia constant, and correction terms to be applied to the results obtained from the curves, to adjust for this departure from assumed conditions, will be given.

32. Application of Data

The procedure for using the curves is as follows:

(1) First, it is necessary to determine the reactance between the internal voltages of the sending- and receiving-end machines. This reactance should be expressed in percent, based upon the total capacity of the generating units in operation at the time the fault occurs. If the exact

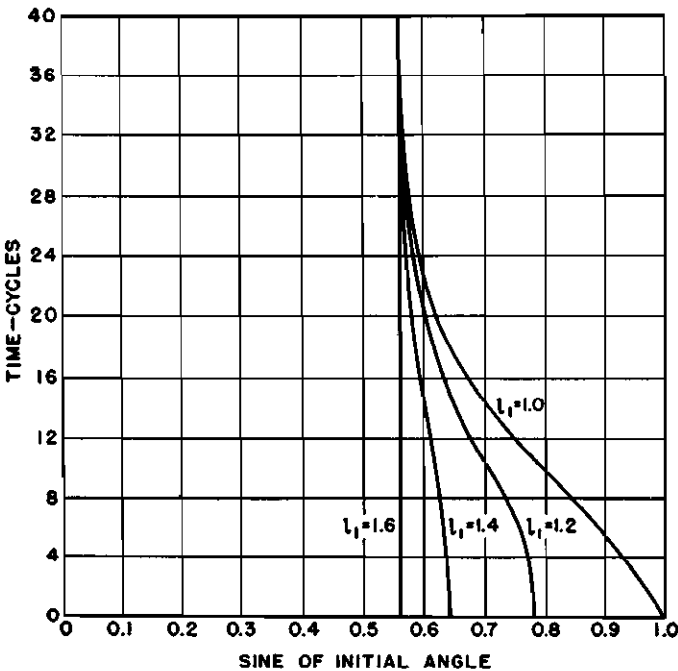

**Fig. 46—Maximum permissible duration of fault to maintain stability:
SINGLE LINE-TO-GROUND FAULT**

machine constants are not known, an average value can be assumed from the synchronous-machine constants given in Table 4 of Chap. 6. If other than full load is assumed, the reactance thus determined must be multiplied by the ratio of assumed load to full load.

(2) Using the value of reactance just determined, the initial angle can be found from Fig. 50.

(3) By reference to Fig. 45, the section of line that must be removed from service to clear the fault is known, so that the ratio l_1 of reactance after the fault is isolated to the initial reactance can be determined.

(4) Using the sine of the initial angle determined in (2) and the ratio l_1 , determined in (3), the time in cycles should

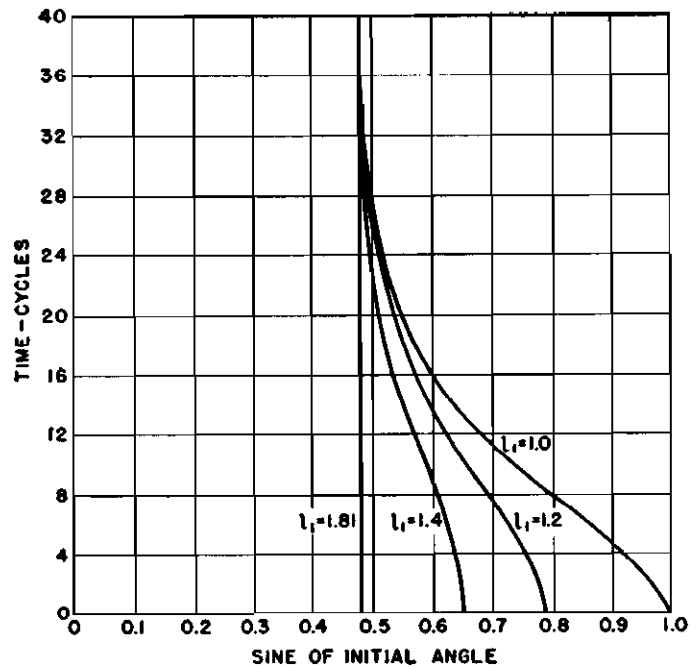

**Fig. 47—Maximum permissible duration of fault to maintain stability:
LINE-TO-LINE FAULT**

be read from the curve (Figs. 46–49) for the type of fault being studied.

(5) The inertia constants for the sending- and receiving-end machines should be determined. If the total mechanical inertia of the machines at one end is known, the inertia constant for that end of the system can be determined by using Eq. (37) appearing in Sec. 22. In case the inertia is not definitely known, an average value can be obtained by

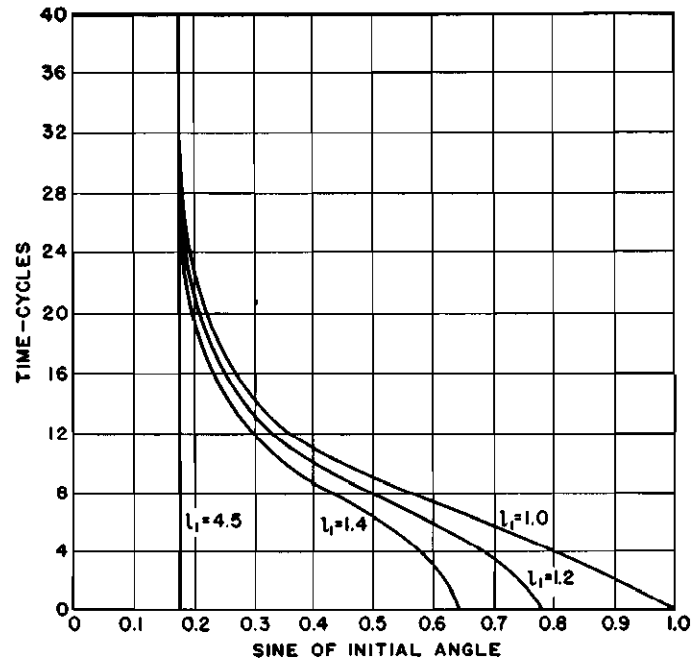

**Fig. 48—Maximum permissible duration of fault to maintain stability:
DOUBLE LINE-TO-GROUND FAULT**

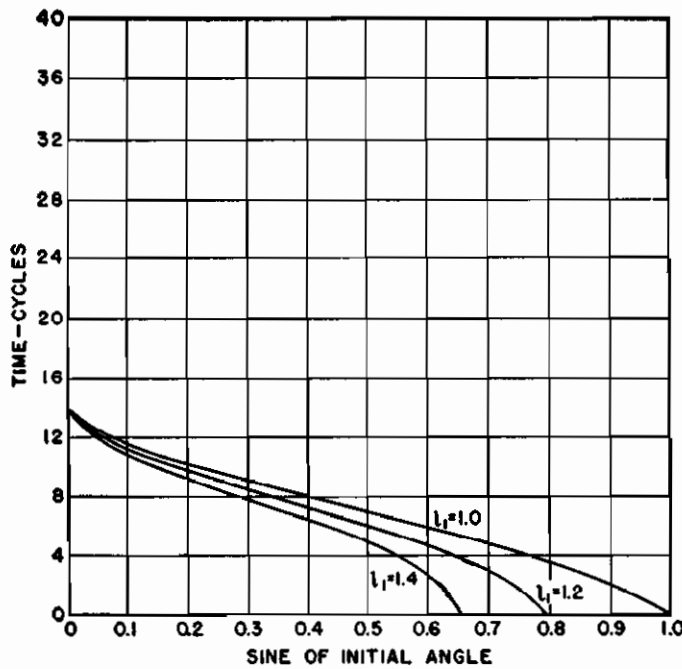

Fig. 49—Maximum permissible duration of fault to maintain stability:
THREE-PHASE FAULT

reference to Table 8. When the inertia constants, H , in kw-seconds per kva, for both ends of the system are known, the inertia correction factor by which the values of time should be multiplied can be found by reference to Table 6, or to the following equations from which Table 6 has been prepared.

$$H_{sr} = \frac{1}{\frac{1}{H_s} + \frac{1}{H_r}} = \frac{H_s H_r}{H_s + H_r} \quad (63)$$

$$k_1 = \text{Inertia correction factor} = \sqrt{\frac{H_{sr}}{1.5}} \quad (64)$$

In these equations H_s and H_r are the inertia constants of the sending- and receiving-end machines, in kw-seconds per kva, respectively.

(6) If the frequency is other than 60 cycles, the result should be multiplied by the square root of the ratio of the new frequency to 60 cycles.

(7) If the load at the time the fault occurs is not equal to the kva rating of the generators, the result should be divided by the square root of the ratio of the actual kw load to the generator rating in kva.

Example: In order to illustrate the use of the short-cut method just described, the single-machine problem calculated in Part V of this chapter will be solved and the resulting maximum circuit-breaker clearing time will be compared to that obtained by the complete calculation. The assumed system is defined in Sec. 24, and the 50 000-kw load assumed there will still apply.

The total generator capacity is 60 000 kva and the transient reactance on this base, of the two machines in parallel, is 25.4 percent.

The assumed transformers each have eight percent reactance on a 60 000-kva base.

Each transmission line was calculated to have a positive-sequence reactance of 39.7 ohms, which can be converted to percent on this same base by conventional methods. Each line represents 54.7 percent on 60 000 kva, and the two lines in parallel equal 27.4 percent.

The receiver has no reactance since it was assumed to be an infinite inertia system of large capacity.

The total reactance between generator internal voltage and the infinite receiver is then:

Generators	25.4 percent
Transformer	8.0 percent
Two lines in parallel	27.4 percent
Transformer	8.0 percent

Total 68.8 percent on 60 000 kva.

The assumed load is 50 000 kw, so the ratio of actual load to generator rated kva is 50 000 divided by 60 000, or 0.833. Hence, at the present load, the reactance is,

$$68.8 \times 0.833 = 57.4 \text{ percent.}$$

From Fig. 50, the initial operating angle is approximately 32 degrees, the sine of which is 0.53. Note that

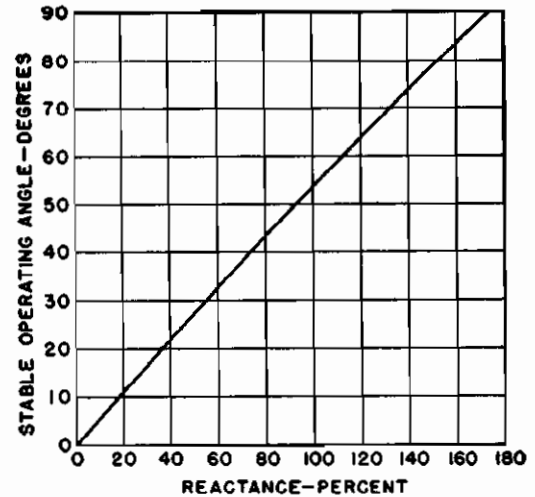

Fig. 50—Initial operating angle as a function of reactance.

the figure of 32 degrees checks closely the initial operating angle determined in the detailed calculation.

When one line is switched out to isolate the fault, which was assumed to be double line-to-ground, the reactance increases to,

$$(68.8 + 27.4)0.833 = 80.1 \text{ percent.}$$

Hence,
$$l_1 = \frac{80.1}{57.4} = 1.4$$

From Fig. 48, which applies for a double line-to-ground fault, corresponding to sine of initial angle = 0.53 and $l_1 = 1.4$, it is seen that $t = 5.8$ cycles, approximately.

From Table 6, corresponding to $H_s = 3$ and $H_r = \infty$, $k_1 = 1.41$.

Since the initial load is 0.833 times the generator kva rating, the corrected maximum time to fault isolation is,

$$t = 5.8 \times \frac{1.41}{\sqrt{0.833}} = 8.94 \text{ or approximately 9 cycles.}$$

TABLE 6—INERTIA CORRECTION FACTOR, k_1 .
(Computed from Eqs. (63) and (64))

H_s or H_r	H_s or H_r								
	2	3	4	8	10	11	12	50	∞
2	0.816	0.894	0.943	1.03	1.05	1.06	1.07	1.13	1.15
3	0.894	1.00	1.07	1.21	1.24	1.25	1.26	1.37	1.41
4	0.943	1.07	1.15	1.33	1.38	1.40	1.41	1.57	1.63
5	0.977	1.12	1.22	1.43	1.49	1.51	1.53	1.74	1.83
6	1.00	1.15	1.26	1.51	1.58	1.61	1.63	1.89	2.00
8	1.03	1.21	1.33	1.63	1.72	1.76	1.79	2.14	2.31
10	1.05	1.24	1.38	1.72	1.83	1.87	1.91	2.36	2.58
11	1.06	1.25	1.40	1.76	1.87	1.91	1.96	2.45	2.71
12	1.07	1.26	1.41	1.79	1.91	1.96	2.00	2.54	2.83
50	1.13	1.37	1.57	2.14	2.36	2.45	2.54	4.08	5.77
∞	1.15	1.41	1.63	2.31	2.58	2.71	2.83	5.77	∞

This figure matches the one obtained by detailed calculation to within the limits of accuracy of reading the curves, and shows that the quick-estimating curves when carefully applied give results that are dependable, as long as the actual system being considered is similar in circuit elements to the assumed system of Fig. 45.

Limitations in Using Curves—The greater the number of arbitrary assumptions and the larger the departures from the assumed conditions, the greater the resulting error. However, for systems of average characteristics the results are satisfactory. For example, if the actual system has no voltage regulators, the permissible fault duration is materially reduced. This is particularly true for cases where long fault duration is permitted. Also, if there is no high-tension bus in the actual case, more synchronizing power can be transmitted while the fault is on the system, but a greater increase in reactance occurs when the faulted line and transformers are removed as a unit from the system, so that the two effects are in the direction to compensate.

Where large steam generators are closely connected to the receiving end of the system, the effective initial angle is not determined solely by the transfer reactance from the sending-end generators, but is usually reduced considerably by the receiving-end generators. This can be taken into account approximately by reducing the reactance of the receiver machines. Where the power supplied by the receiving-end generators is greater than about three times that of the sending-end machines, it is safe to neglect the receiver reactance, and measure the total reactance to the receiver low-tension bus.

In the foregoing all breakers necessary to isolate the fault were assumed to open simultaneously. In practice, when the fault is near one breaker, a basis of discrimination for tripping the breaker does not exist until the first breaker has opened; hence the two breakers operate sequentially. In such cases the fault duration is increased to twice the time of a circuit-breaker opening. Where the distance from the fault location to each bus is short, this will require a breaker-opening time of half the permissible fault duration. If, however, the line reactance between busing points is high, the severity of the fault is greatly reduced and a longer total duration is permissible, up to probably 50 per-

cent longer than the figure obtained from the curves. The corresponding time for each breaker will thus increase to about two-thirds of the curve values. Consideration of the reactances involved will indicate a reasonable correction to be used in an individual case.

VII. METHODS OF STABILITY CALCULATION—MULTI-MACHINE SYSTEMS

33. Simplification of Networks with Multi-Machine Systems

The method of solving multi-machine stability problems follows closely the procedure just described for the general case for two-machine systems, and the same steady-state and step-by-step transient procedures should be used. The first step in the solution of multi-machine problems is to set up the equivalent network for lines, loads, and other shunt branches and for machines as previously described for the general two-machine system. Such networks involve a series impedance between each internal emf and the remainder of the system. Such a network does not lend itself to analytical calculations and should be replaced by mesh-connected systems with a single-impedance branch connecting each pair of internal emf's. For example, Fig. 51 shows a typical network for a three-machine system, characterized (1) by a hydro-electric source with voltage E_1 , and (2) by two receiver machines which have voltages E_2 and E_3 , which are connected together and to the hydro-electric machine by transmission lines represented by equivalent π method.

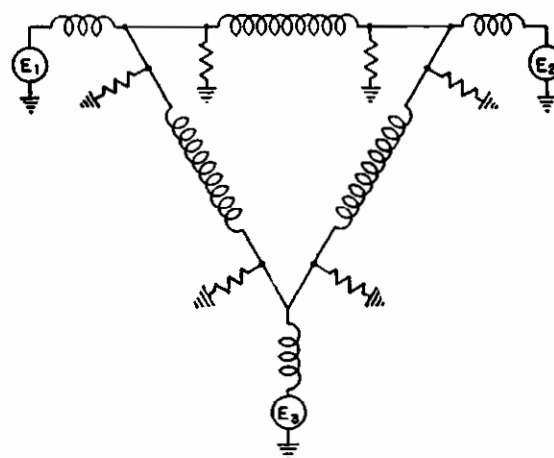

(a) TYPICAL NETWORK WITH THREE MACHINES

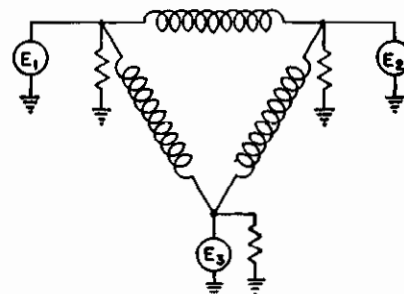

(b) EQUIVALENT MESH-CONNECTED NETWORK

Fig. 51—Method of reducing networks to the form convenient for stability studies.

Such a network should be transformed by the methods previously discussed in Chap. 2 to the form shown in Fig. 51 (b). This network involves only (1) shunt branches connected directly across the internal voltage ordinarily assumed constant and (2) mesh-connected branches connected directly between pairs of internal emf's. The power equations for such a system are readily written for each line in terms of the source emf's, in magnitude and phase position, and the series impedance of that line. Thus, it is readily possible to determine the electrical output or input for each machine if the phase position and magnitude of the various internal emf's are available.

Analytical methods of calculation can be applied to systems involving more than three machines by using the same procedure just described in connection with the three-machine system of converting the network to the simplest mesh-connected system. Such a procedure has been used for the solution of four-machine systems.¹⁰ However, the complication increases rapidly with the number of machines, and it is not practical to carry out calculations for systems with more than three or at the most more than four machines.

34. Steady-State Solution for Multi-Machine Systems

The determination of the steady-state stability limit for a multi-machine system is a problem of considerable

complexity.^{10,36} This results from the many conditions to be considered and the laboriousness of the calculations. Additional complication is introduced if, as is usually the case, automatic voltage regulators are used. Fortunately, however, the problem when considered from the practical viewpoint is greatly simplified because it becomes one of determining whether a particular system is stable for an assumed load below the actual stability limit. Under these conditions, many of the complicating factors are eliminated. It is often necessary to provide a considerable margin between the steady-state power limit with fixed excitation and the assumed operating conditions. A further factor is the action of automatic voltage regulators in increasing limits due to phenomenon of dynamic stability. For these reasons little effort is directed toward the determination of the actual stability limits of multi-machine systems. Instead, the problem takes the form of showing that the system is stable for a particular set of assumed conditions. Usually the important limit is the transient stability limit.

The practical method of solving stability problems of central-station systems is by means of the a-c network calculator.¹⁸ Analytical methods become exceedingly laborious for cases involving more than three or four machines. The average central-station utility problem usually involves more than this number of machines and solution is more easily done by a-c network calculator.

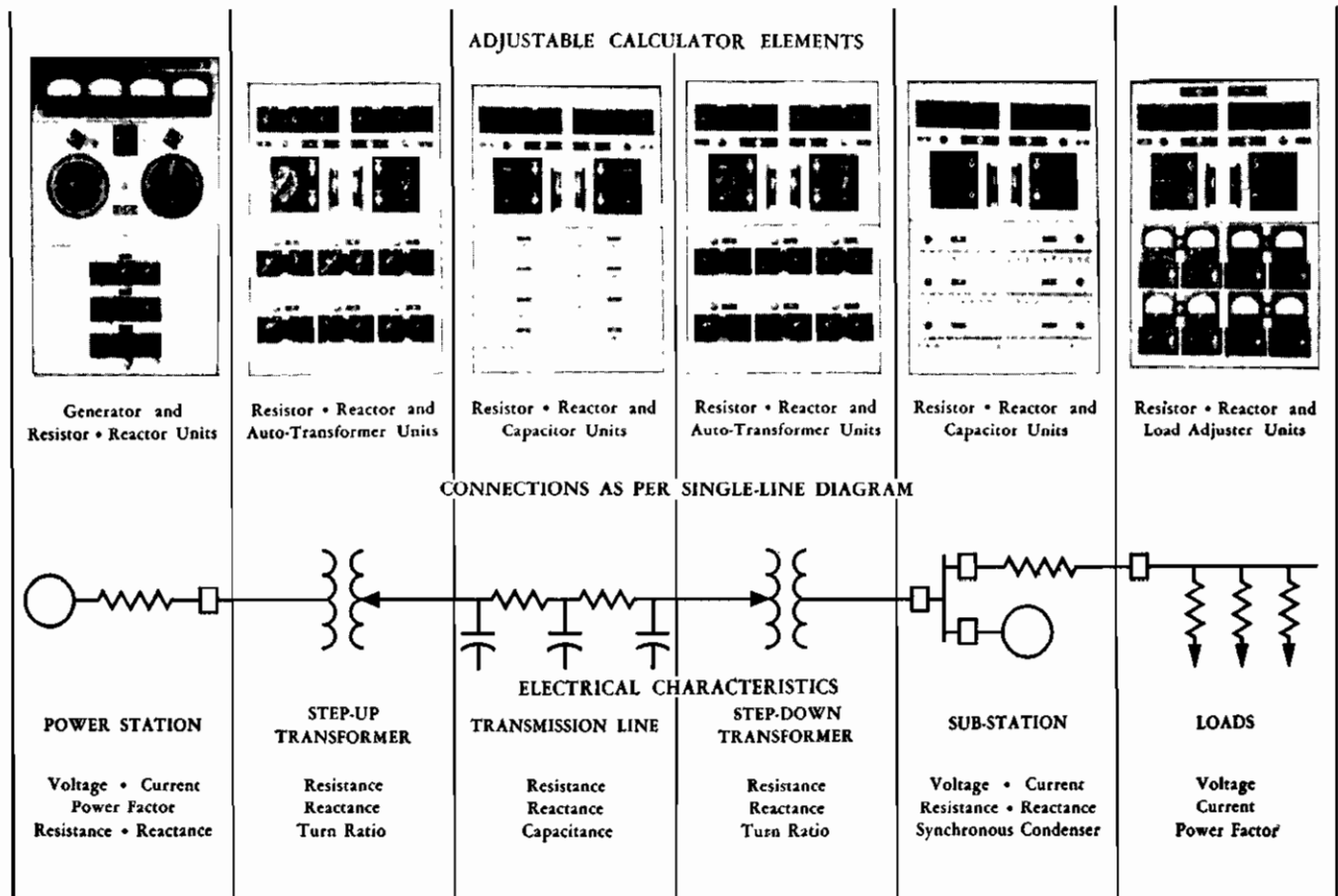

Fig. 52—Various system elements and the calculating-board elements used to represent them.

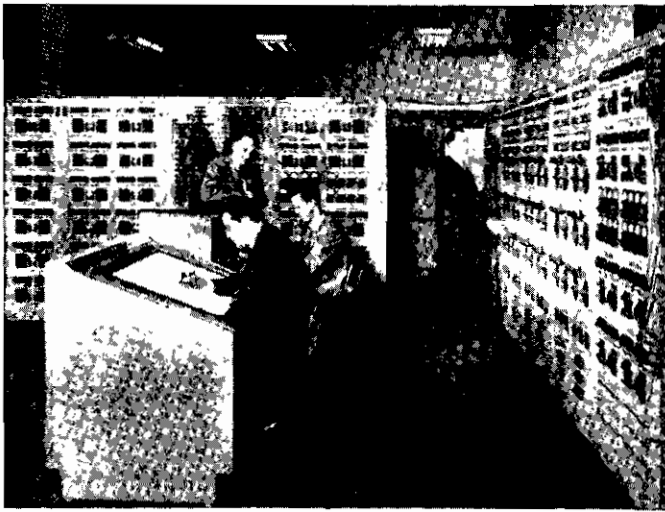

Fig. 53—The a-c network calculator at East Pittsburgh.

35. The A-C Network Calculator

The general design of the a-c network calculator is such that all of the essential elements of a modern power system can be reproduced in a miniature replica. The various parts are reproduced accurately in suitable proportion to the system values, and observations and measurements on the replica network correspond to what would obtain under like conditions on the power system. Suitable multipliers or conversion factors readily translate the calculator readings of voltage, current, watts, and vars

into the power system values. Various power-system elements and the corresponding calculator circuits are illustrated in Fig. 52, and a general view of the calculator is shown in Fig. 53.

The number and types of circuits provided in the Westinghouse a-c network calculator at East Pittsburgh are listed in Table 7.

The power supply for the calculator consists of a 440-cycle, 220-volt motor-generator set, which has its voltage controlled by an electronic voltage regulator and an electronic exciter to provide quick response and accurate regulation. The generator of this set supplies three-phase power to the calculator generator units, which are actually regulators especially designed to convert the three-phase power input to a single-phase power output having adjustable magnitude and phase angle.

Two independent sets of master instruments, circuit selector and metering controls are provided, each set being mounted on a separate metering and control desk. Direct readings of either scalar or vector values of currents and voltages, and magnitudes of watts, vars, and phase angles can be obtained. The two metering desks provide for conducting two simultaneous studies of separate systems with independent control of each system. Any calculator unit can be instantly connected to the metering equipment by a remote-control circuit selector which enables metering of system quantities at any point in the system.

The determination of the electrical conditions on the a-c network calculator gives practical solutions for the

TABLE 7—NETWORK CALCULATOR CIRCUIT ELEMENTS

Number of Circuits	Type of Circuit	Prefix	Used to Represent	Range of Adjustment		Steps
22	Generator units with voltmeter, ammeter, wattmeter, and varmeter	G	Generator, phase-shifting transformer, etc.	Voltage:	0- 400%	Smooth
				Angle:	0- 360°	Smooth
18	Low-loss reactors	X	Generator reactance	React:	0- 499%	0.2
128	Line-impedance units	—	Lines, transformers, etc.	Resis:	0- 399%	0.2
				React:	0- 301%	Smooth
40	Transmission-line Pi units	—	Long, high-voltage transmission lines	Resis:	0- 399%	0.2
				React:	0- 301%	Smooth
				Suscept:*	0- 41%	0.1
48	Load-impedance units with load adjusters and voltmeters	L	Shunt loads	Resis:	0-3990%	2.0
				React:	0-2400%	Smooth
				Load Adj:	±10%	1%
48	Condenser units	C	Line-charging capacity, synchronous condensers, negative reactance	Mfd:	0- 4.1	0.1
36	Autotransformer units	T	Transformer taps, regulators	80% to 124.5%		½%
36	1 to 1 ratio transformers	M	Mutual induction, or used as 2 to 1 autotransformers for extended range studies	—		—
48	Metering jumper circuits	J	Zero-impedance metering jumper circuits	—		—

*Susceptance at each end of Pi unit.

many design and operating problems of electrical systems. The most common problems may be classified as:

- a. voltage-regulation studies for determining bus voltages, load-control studies and current-distribution studies, either as a system-design or an operating problem and for normal or emergency conditions,
- b. short-circuit studies for circuit-breaker and protective-relay application, and
- c. steady-state and transient-stability studies for determining the power limit of transmission systems.

36. Transient-Stability Solutions on the A-C Network Calculator

For stability purposes the problems need be considered merely as the solution of a set of simultaneous equations under successive steady-state conditions. The transient-stability solution, by the step-by-step procedure, is obtained by a succession of appropriately-adjusted steady-state conditions.

The system is reduced to a common base and is normally set up on the calculator on the basis of the positive-sequence network, using transient reactance in series with the generator voltage. Where large synchronous condensers are involved and the inertia of these condensers must be considered, they are represented by a voltage behind the condenser transient reactance.

The system is set up for the conditions prior to the disturbance, and the generator internal voltage, power, and angle are read at the point behind the generator reactance. The power so obtained is assumed to be the mechanical input to the generator and is maintained constant throughout the study, assuming that during the short time being considered, the governor cannot change. The internal voltage is also maintained constant throughout the study. The internal angle initially read is the normal angle, and the departure from this angle is calculated from the generator power output and machine dynamic characteristics.

The fault is then applied at the desired point in the system by connecting that point to the neutral bus in accordance with the type of fault as described in Sec. 10. The internal angles and voltages of the generators are adjusted to the values measured before the fault was applied, and the power distribution read. The difference between the power before the fault and the power after the fault is the accelerating or decelerating power available for changing the angular position of the machine rotor. From the relations between the machine inertia, the change in power, and the time interval, the change in angular position of each machine rotor is calculated, and the generator internal angles shifted to these new values. The procedure is repeated for the next time interval, and so on throughout successive intervals until the system is proven either stable or unstable for the conditions being studied.

The a-c network calculator provides a means not only for solving stability problems but also for obtaining the time variation of all the related electrical and mechanical quantities useful for circuit-breaker and relay application and for other similar purposes. The network calculator is also a device for simplifying networks and reducing them to a simpler form for more detailed study. By these meth-

ods, exceedingly complicated systems can be set up on the calculator and a practical solution obtained.

37. Two-Reaction Method Using A-C Network Calculator

The a-c network calculator also provides a means for carrying out in a practical manner calculations of complicated systems using the two-reaction method*. For this purpose each machine should be laid out so as to have two sources of voltage electrically at right angles to each other. The vector diagram for a salient-pole generator under transient conditions is shown in Fig. 25. One of these sources would represent the voltage E_d' , the magnitude and phase position of which are associated with the excitation and with the rotor position. At right angles to this vector is the voltage E_q' , which represents the reactance drop due to flux in the quadrature axis. The value of this voltage is assumed to vary instantly† so as to provide the proper quadrature-reactance drop. For each point in the stability analysis the voltage in the quadrature axis is adjusted until the vector diagram is satisfied for the particular terminal condition.

An alternative method requiring only one source of voltage for each machine is outlined in Chap. 6. This method uses the quadrature-axis reactance to relate rotor position, direct- and quadrature-axis voltages, and the terminal quantities. The method is, therefore, based on the adjustment of the network-calculator settings to allow for the variation in the direct- and quadrature-axis voltages whose transient values are separately calculated.

Both methods involve a cut-and-try proposition and are somewhat tedious. The principal merit of such a method is that it provides a basis for estimating the difference in results with the two-reaction method and the conventional round-rotor method which is generally found adequate.

VIII. SHORT-CUT METHODS OF CALCULATION—METROPOLITAN SYSTEM

The discussion in Part VI describes a useful short cut in calculating transient stability on transmission systems. Similarly, a general study has been made and general curves presented for the quick estimation of transient-stability limits on metropolitan-type systems.²³ In this discussion a metropolitan-type system is considered to be one in which the principal power sources are steam generating stations, located relatively close to their load centers, with distribution provided by a multiplicity of moderate-voltage circuits. The power supply to most metropolitan districts is of this character; there are, of course, notable exceptions.

Although most systems of this type are inherently stable as compared to systems coupled with long transmission lines, nevertheless transient stability analyses are frequently desirable. For example, other aspects of system

*This method was first used for analytical calculations by C. F. Wagner and R. D. Evans⁶; it was adapted for use with the a-c network calculator by Dr. W. A. Lewis.

†The basis for the rapid variation of quadrature-axis flux was shown experimentally in Reference 5.

operation, such as placing of new generation, reduction of short-circuit kva, and flexibility of operation may suggest layouts differing from those at present in use, and it is desirable to be able to evaluate whether the desired changes will increase or decrease the transient limits, and whether the resulting value is satisfactory.

38. General Stability Curves

Metropolitan systems, as defined above, are similar in major characteristics making generalized studies practical. They are usually similar in the following features:

1. With equal percent loadings the internal voltages of all generators are essentially in phase.

2. With a multiplicity of circuits, the reactance of the connecting lines holding a generator or group of generators in step with the system does not change appreciably when a fault is cleared.

3. With turbo-generators and short lines involved, the generator characteristics are no longer affected by the speed of prime mover, line charging-current requirements, etc., and they tend to become fairly uniform in their essential points, such as reactances, inertia, and short-circuit ratio.

These similarities make it possible to calculate transient stability solutions for a number of hypothetical systems and give the results in curve form, using the remaining variables as indices. The curves are then applied to specific layouts by determining these quantities for the specific case.

Space is not justified to include the derivation of the general curves, but the complete procedure is described in the paper in which these curves were originally presented, "Generalized Stability Solution for Metropolitan-Type Systems" by Griscom, Lewis, and Ellis.²³ In developing the curves some minor influences had to be eliminated from consideration with some sacrifice in accuracy of results. Such influences include resistance in the lines and the fault, variations in generator loading, and the effect of voltage regulators. The errors introduced by neglecting these influences, and possible means for compensating for them, will be discussed in a later section.

The general stability curves for metropolitan-type systems are shown in Fig. 54. These curves assume that the generators have a short-circuit ratio of 1.0. In the paper originally presenting these curves, a similar set was included using a generator short-circuit ratio of 0.8, but the resulting differences are so small that both groups of curves are not included here. Part (a) of Fig. 54 consists of a family of curves covering the range of overall reactance X , plotted in terms of short-circuit current, I_{FG} , from the faulted generator and the permissible fault duration, t . Part (b) is similar except that the power dropped by the faulted generator is used instead of I_{FG} . Part (c), as will be explained later, provides a means of correction for resistance in the fault, and for other than rated initial load. Part (a) applies directly to faults at the generator terminals. For faults occurring at other locations, a close approximation is secured by dividing I_{FG} by a factor read from Part (c) before entering Part (a). This location factor, designated as r_{FG} , is a function of the ratio of I_{FG} to I_F , the total fault current.

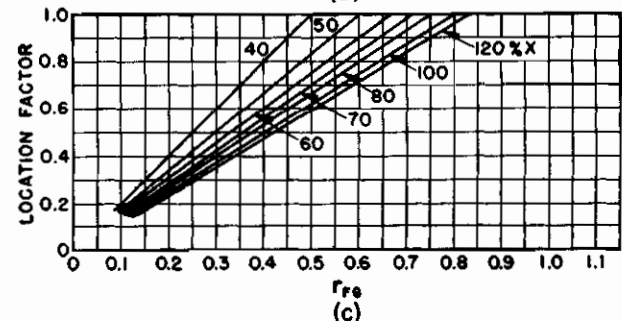
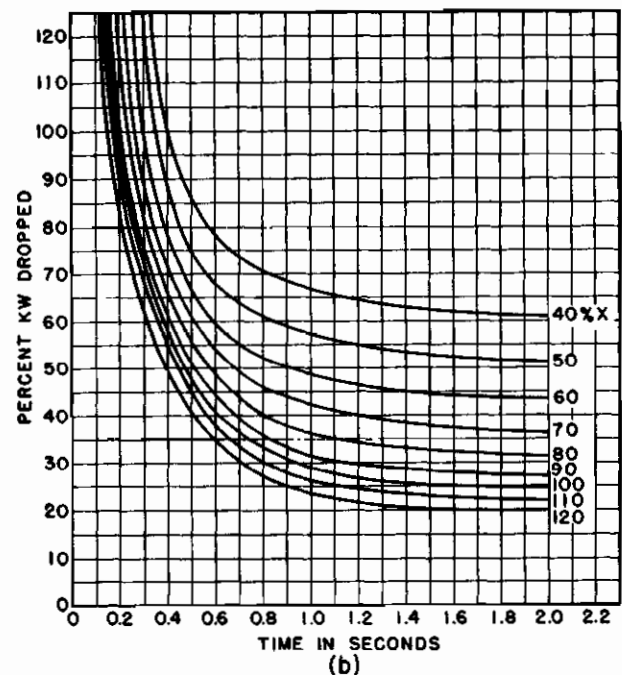
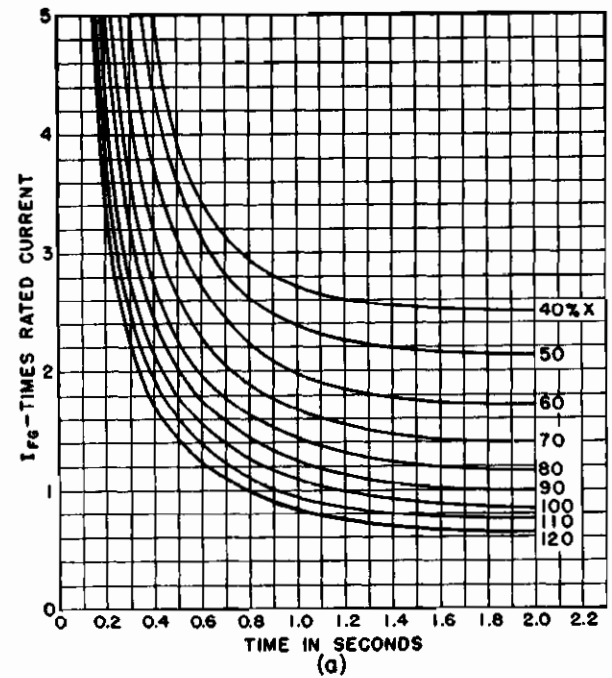

Fig. 54—General stability curves for metropolitan-type systems.

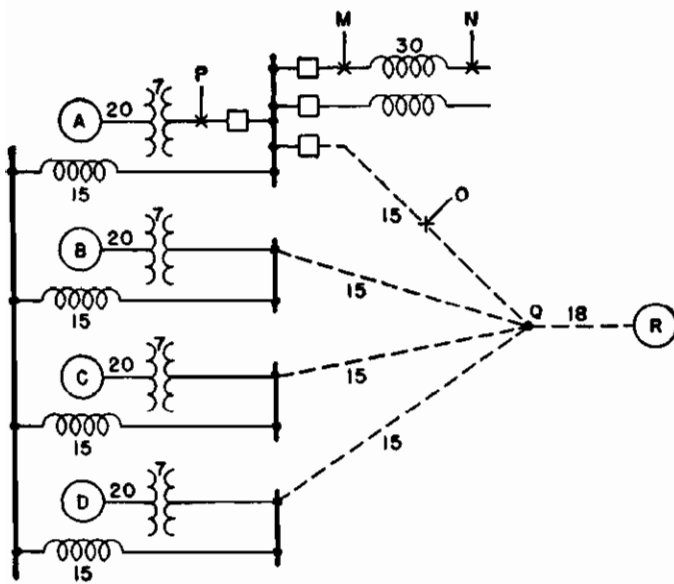

Fig. 55—Typical metropolitan-type system selected to demonstrate application of curves.

39. Application of Curves

An example is chosen to illustrate the application of this short-cut method for metropolitan systems. The typical system is shown schematically in Fig. 55, with reactances as indicated. A three-phase fault at point *M* will be considered. This fault isolates generator *A* from the remainder of the system during the fault, and this unit is then the one most likely to pull out of step first. Generator *A* therefore becomes the "faulted generator," and all other machines including those in the same group become the "remaining generators." With a fault at *M*, the network of Fig. 55 reduces to that of Fig. 56. The actual reduction can be accomplished analytically or, more easily, by using a d-c network calculator (since resistances are not included). If the network calculator is used, the actual reduction to the form shown in Fig. 56 need not be completed, as the

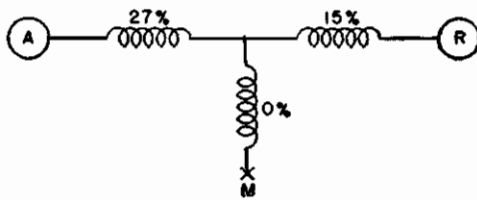

Fig. 56—Network of Fig. 55 reduced to equivalent for fault at *M*.

necessary indices can be obtained from the current readings taken to perform the reduction. From Fig. 56, the total reactance X between the faulted generator and the remaining generators is $27 + 15 = 42$ percent (always on the rated-kva base of the faulted generator). To determine the total fault current I_F , the branches on each side of the fault are paralleled:

$$\frac{(27 \times 15)}{42} = 9.65 \text{ percent,}$$

and the total fault current is $1/0.0965 = 10.4$ times the

rating of generator *A*. The fault current supplied by the faulted generator is:

$$I_{FG} = \frac{15}{42} \times 10.4 = 3.7 \text{ times rated current.}$$

The ratio of I_{FG}/I_F gives $r_{FG} = 0.357$, so that now the indices necessary to use the curves of Fig. 54 are:

Overall reactance X	= 42 percent
Current from faulted generator	= $3.7 \times$ rating
Ratio $I_{FG}/I_F = r_{FG}$	= 0.357.

Using this value of r_{FG} and interpolating for a reactance of 42 percent, Fig. 54 (c) gives a location factor of 0.7. The adjusted value of I_{FG} is then 3.7 divided by 0.7 = 5.3, and the permissible fault duration can now be read from Fig. 54 (a) (by extrapolation) and is found to be 0.39 seconds.

If the fault occurs at point *N* of Fig. 55, outside of the feeder reactor, the circuit reduces to that shown in Fig. 57. The overall reactance does not change, but a high-reactance shunt branch is introduced to represent the reactor. It will be found for this case that r_{FG} remains the same because it depends only on the reactance branches adjacent to the generators. The total fault current is greatly reduced owing to the presence of the 30-percent reactance

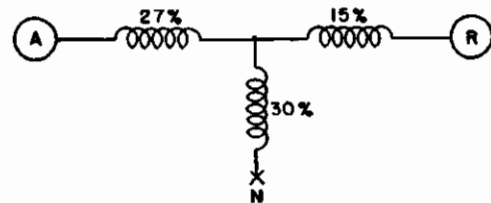

Fig. 57—Network of Fig. 55 reduced to equivalent for fault at *N*.

in series with the fault point, and becomes 2.52 times rated current of machine *A*. In this case I_{FG} calculates to be 0.9 times rated current, and when adjusted for location becomes $0.9/0.7 = 1.29$. When these indices are referred to Fig. 54 (a), it is evident that the point is beyond the range of the curves, and the permissible fault duration exceeds two seconds.

If the fault were at point *O* of Fig. 55, it would affect all four of the generators in station *A* more equally. Hence, there is a possibility that this entire group may lose synchronism with the remainder of the system. In this case, the group should be considered as the faulted generator, and all indices should be expressed in terms of the rating of the group as a base. This solution can be compared with that for generator *A* considered as the faulted unit, and the shorter of the two figures for permissible fault duration should be taken as the result.

Now, suppose that the three-phase fault occurs on the leads of generator *A*, as designated by *P* in Fig. 55. In this case generator *A* must be disconnected from the system to isolate the fault, and this must be accomplished before machines *B*, *C*, and *D* lose synchronism with the remainder of the system. Generator *A* is isolated from the system by the fault while the fault persists, and is isolated by the breaker when the fault is cleared, hence *B*, *C*, and *D* only are considered as the faulted generators, and generator *A* is eliminated from the calculation. By reduction of the

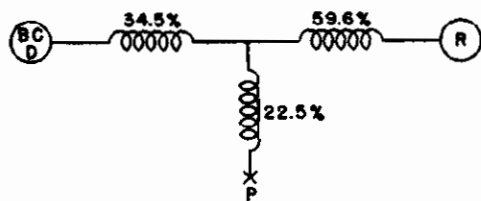

Fig. 58—Network of Fig. 55 reduced to equivalent for fault at P .

network of Fig. 55 for a fault at P , the simplified equivalent shown in Fig. 58 is obtained, the reactances now being expressed in percent on the combined kva rating of machines B , C , and D . From this point the calculations are identical to the previous examples, and the maximum fault duration is determined to be 0.53 seconds.

Unbalanced Faults—In the foregoing paragraphs three-phase faults have been assumed to demonstrate the application of the general curves. If unbalanced faults are to be considered, the method of symmetrical components can be used by adding a series impedance at the point of fault, which impedance is a function of the negative- and zero-sequence networks. This procedure is illustrated in Secs. 26 and 30 of this chapter and discussed in Sec. 10.

40. Correction Factors

As stated above, certain factors influencing stability were not considered in the preparation of the general curves. These simplifying assumptions all tend to make the permissible fault duration shorter, or to make the transient-stability solution more critical. The curves of Fig. 54 can thus be used directly for most work without applying correction factors since the error will consistently be on the safe side. It is appreciated, however, that the effect of some of these neglected considerations may be of interest in specific cases, so approximate corrections are presented, which while they are not rigorously correct, should be accurate enough for most practical work.

Effect of Resistance—The usual resistances present in power circuits have a minor effect on stability, except for the resistance in the fault circuit. Because of the very large currents in the fault circuit, a small resistance will result in a large power loss, which in a measure compensates for the drop in load on the faulted generator and lessens the tendency to pull out of step. Parts (a) and (b) of Fig. 54 are plotted for faults at the generator terminals. Applying the location factor from Fig. 54 (c) converts a fault at any other location to its equivalent fault at the generator terminals. For each point in Part (a) there is a corresponding point in Part (b), from which may be found the amount of power which would have to be dropped by the faulted generator for the equivalent fault at its terminals. If the amount of power dropped is reduced by resistance in the lines or fault, the effect would be substantially the same regardless of fault location. Hence the result may be found by reducing the equivalent amount of power dropped by the amount of resistance losses taken by the faulted generator, and reading the corrected fault duration from Fig. 54 (b). For example, with the fault at point M of Fig. 55, a clearing time of 0.39 seconds was indicated by Fig. 54 (a). The same clearing time must be indicated by Fig. 54 (b), hence, for $X = 42$ percent and $t = 0.39$, it is found that 100

percent power would have to be dropped by the machine if the fault were at its terminals. The curves show this power dropped as percent of the generator kilowatt rating, which is assumed 85 percent of the kva rating. If machine A and its transformer have a resistance of 1.5 percent, then with 3.7 times rated current flowing, the I^2R loss in the machine and transformer is $(3.7)^2 \times 1.5 = 20.5$ percent of the generator kva rating, or 20.5 divided by 0.85 = 24 percent of its kilowatt rating. So, instead of 100 percent load dropped, the equivalent load dropped is 100 minus 24, or 76 percent. The permissible fault duration, considering the effect of resistance, is then determined from Fig. 54 (b) for $X = 42$ and power = 76 to be 0.6 seconds.

If resistance in the fault itself is to be considered, the power loss in the fault must be divided between the faulted generator and the remaining generators. An approximate method of doing this is to multiply the total loss in the fault by r_{FG} , and add this figure to the loss in the generator branch of the circuit. For example, for the fault at M assume 0.25 percent resistance in addition to that of the generator and transformer. With 10.4 times normal current, $(10.4)^2 \times 0.25$ or 27 percent of generator kva is created in the fault. This is equal to 27 divided by 0.85 or 31.8 percent of generator kilowatt rating. Then multiplying by r_{FG} , $31.8 \times 0.357 = 11.3$ percent power in the fault taken by the faulted generator. As determined above, the power dropped is 100 percent when $X = 42$ percent and $t = 0.39$ seconds (from Fig. 54 (b)). When 24 percent resulting from generator and transformer resistance and 11.3 percent resulting from fault resistance are subtracted, 64.7 percent remains as the equivalent power dropped. From Fig. 54 (b) this amount of power dropped is seen to give a permissible fault duration of 2.0 seconds.

Initial Generator Load—The general curves assume that all generators are loaded to 100 percent of their kilowatt rating. For other than rated load, first find the percentage of kilowatts dropped, corresponding to X and t for rated initial load, then multiply this by the ratio of initial load to full load, and read the corrected permissible fault duration from Fig. 54 (b), for the curve corresponding to X . For example, with $X = 42$ percent, $t = 0.39$ seconds, 100 percent kilowatts is dropped, and if the initial load had been 75 percent instead of 100 percent, the fault duration can be read as $t = 0.61$ seconds for kilowatts dropped = $100 \times 0.75 = 75$ percent and $X = 42$ percent.

Voltage Regulators—Regulators with a moderate rate of response give a certain amount of improvement in stability over the amount shown by the curves of Fig. 54. The exact magnitude of this increase is difficult to determine, but a reasonable idea of the improvement can be easily obtained by multiplying the value of I_{FG} by 0.85 before entering the curves of Fig. 54 (a). This gives a relatively good estimate over most of the range of the curves.

IX. ESTIMATING PERMISSIBLE TRANSMISSION LINE LOADING

41. Surge-Impedance Loading

When a resistance equal to the surge impedance of a resistanceless transmission line is connected across the receiving end of the line, a surge introduced into the sending

end is absorbed completely without reflection. Thus a sinusoidal voltage introduced into the sending end travels along the line and is completely absorbed. The voltage at the receiving end varies sinusoidally with time, has the same magnitude as the voltage at the sending end, and is displaced by an angle equivalent to the time required for the wave to move from one end of the line to the other.

The load delivered over the line to the resistance is called "surge-impedance loading." Based on an average value of surge impedance of 400 ohms,

$$SIL = 2.5(kv)^2 \tag{65}$$

where

- SIL = surge-impedance loading in kw
- kv = line-to-line kilovolts of transmission line
- 2.5 = a constant derived from the average surge impedance as shown in Chap. 9.

Thus, surge-impedance loading is a constant for lines of a particular operating voltage and can be used as a basis for comparison of lines operating at different voltages. The following analysis derives a simple method of determining the permissible loading of a straight-away transmission line based on a transient-stability criterion and expressed in terms of surge-impedance loading and the line length in miles.

42. Criterion of Stability

A rigorous determination of the power limit of a system is dependent upon many detailed considerations such as circuit-breaker clearing time, type and location of faults, type and speed of the excitation system, bussing arrangements, line-sectionalizing, station spacing, generator short-circuit ratio, generator inertia constant, etc. Even when extensive work is done along these lines, it is still necessary to apply judgment factors to calculated results. In estimating the permissible loading of long, high-voltage, straight-away transmission lines, a single overall criterion can be used rather than attempting a detailed design of the

system. This criterion is that the operating load, after switching of the faulty line, be 80 percent of the crest of the *transient* power-angle relation.

A justification for this particular value of 80 percent is given in Fig. 59. Curve 1 is a hypothetical power-angle diagram, based on generator transient reactance, having a crest of 100 percent after switching of the faulty line section. The horizontal line P_0 represents the prime-mover input, presumed constant at 80 percent of the crest value and equal to the generator rating.

First, assume a three-phase short circuit at the generator high-voltage bus. The generator output will decrease from 80 percent to zero and remain there until the fault is relieved, after which it follows Curve 1. If the angle of swing is adjusted so that the area bounded by $abcd$ is equal to the area bounded by $aejfg$, the system will have transient stability for a three-phase fault on the high-tension bus, for the time required to increase the angle from c to b , with no margin. The time to increase the angle from c to b can be obtained if the inertia constants of the generators are known. If these are waterwheel generators, H may be about three. The acceleration for dropping full-power output is

$$\alpha = \frac{180f}{H} = \frac{(180)(60)}{3} = 3600 \text{ elec. deg./sec.}^2$$

The angle traversed in time t is

$$\theta = \frac{1}{2}\alpha t^2$$

The angular difference, $b - c$, in Fig. 59 is about 10 degrees, hence the required fault-clearing time

$$t = \sqrt{\frac{2\theta}{\alpha}} = \sqrt{\frac{(2)(10)}{3600}} = 0.075 \text{ second.}$$

Various details have been omitted for clarity in the foregoing. The power does not drop to zero because of machine losses. Curve 1 is not traced because of some decrement. Point d is not the correct starting point, but rather the intersection with P_0 of the unswitched transient power-angle diagram, Curve 0. Also, other values of inertia constant give different required fault-clearing times.

The approximate conclusions are that a three-phase fault on the generator high-voltage bus would result in instability for 8-cycle and 5-cycle circuit breakers. For 3-cycle circuit breakers, the clearing time under ideal conditions would be 0.067 second. However, a fault as severe as a three-phase fault is too rigorous a criterion.

A similar analysis is approximated for a single phase-to-ground fault on the generator high-voltage bus. On the basis of $x_0 = x_1 = x_2$, the power-angle diagram during the fault will have a crest value of about 2/3 of Curve 1. This is shown as Curve 2. Equating area $daghi$ to area $gjfg$ gives an angular change of about 32 degrees, and an approximate required clearing time of 0.275 second. This time can be obtained readily with 8-cycle breakers and carrier-current relaying and allows considerable margin.

From the preceding demonstration, it is considered quite logical to operate a system at a loading equal to 80 percent of the crest of the transient power-angle diagram. It is of interest to note that if the loading were to be increased to

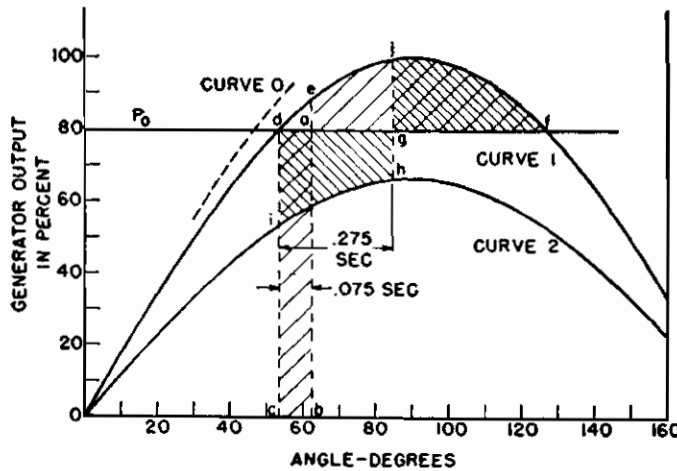

Fig. 59—Hypothetical power-angle diagrams showing switching times for maintaining stability with no margin during three-phase and single line-to-ground faults.

- Curve 1—Power-angle diagram, faulty line switched.
- Curve 2—Power-angle diagram, during single line-to-ground fault.
- Curve 0—Power-angle diagram, system normal.

85 percent of the maximum power, the area above the new P_0 line is markedly reduced; while dropping below 80 percent increases the area rapidly. While 80 percent may not be the best operating point, it is a very reasonable value.

In deriving the curves in Fig. 59, the generator power output was expressed by

$$P = 100 \sin \theta$$

where θ is the angle between sending and receiving voltages. For an actual system, the expression for generator power is

$$P = K_1 E_s^2 + K_2 E_r E_s \sin(\theta - \delta).$$

If P_0 , the maximum operating load, is taken as 80 percent of the crest of the transient power-angle diagram, the area *dejfga* of Fig. 59, available to withstand transient disturbances is reasonably constant over a wide range of system layouts. Essentially, the above analysis was based on $K_1 E_s^2$ being small compared with $K_2 E_r E_s$. In terms of ABCD constants, K_1 is the real component of D/B while K_2 is the scalar value of $1/B$. Unless the resistances of the circuits are quite high, or the lines quite long (beyond one-quarter wavelength or approximately 775 miles), $K_1 E_s^2$ remains small compared to $K_2 E_r E_s$, and close comparisons between systems can be made with the criterion.

The proposed criterion is based on holding the generating station in step with the receiving system during transient disturbances, and presumes that the receiving system inertia is infinite compared with the generating system. This is substantially true for most systems in operation today. In particular, in order for the criterion to apply at all, it is necessary that pull out, should it occur, be due primarily to overspeed of the generating station rather than underspeed of the receiving system.

43. Terminal Equipment Impedance

The transient reactance of the generators and the leakage reactance of the step-up and step-down transformers must be added to the line impedance to obtain the transient power-angle characteristic of the system. The reactance of the terminal equipment can vary through rather wide limits. The generator transient reactance may be as low as 15 percent for turbine generators and as high as 40 percent for slow-speed waterwheel generators. The majority of straight-away transmission systems are in conjunction with waterwheel generators, and generators of lower than normal reactance are used to be able to operate the lines at higher power levels. On this basis, 25 percent represents a fair approximation of the generator transient reactance.

A similar condition applies to the transformers in that the normal transformer reactance varies with voltage rating. At 138 kv, and to a lesser extent at 230 kv, the reactances of normally designed transformers are about ideal considering the opposing requirements to limit short-circuit currents and to obtain maximum stability. At higher voltages, however, it is advantageous to use transformers of reactance lower than normal. A fair average value of transformer leakage reactance is eight percent for transformers at both ends of the line.

The amount of reactance used to represent the receiving

system may vary considerably. For systems in which the transmission system supplies most of the energy used, the receiving-system impedance may represent a large percentage of the total. Where the transmission system merely augments the generating capacity already existing, and in particular where multiple terminals are used, each feeding into existing large systems, the receiver-system impedance may not be much greater than the reactance of the step-down transformer. In this analysis, the receiving-system impedance is taken as the receiver transformer reactance only for two reasons: first, it results in greater line loadings, reflecting possible future improvements in technique, and second, the stability criterion being used is probably on the conservative side.

44. Permissible-Loading Curve

With the foregoing values of reactances set, namely 25-percent generator transient reactance, and 8-percent transformer reactance, permissible line loadings as a function of distance may be obtained. The procedure is to assign a line loading, such that, when terminal equipment impedance is added, P_0 is 80 percent of the crest of the power-angle diagram. The line impedances depend upon the operating voltages, whereas the equipment impedances depend upon the kva ratings.

The first step is to obtain the power-circle diagrams of a transmission line of a given length and voltage including transformers of appropriate size. The expected loading is approximated or assumed, P_s and Q_s are available from the circle diagrams, and E_s , the internal voltage behind generator transient reactance, can be calculated. The generator reactance can then be added to the transformer and line constants, and the equations of the power-angle diagram determined, and hence the crest value of the generator output. If 80 percent of this crest does not equal the loading originally assumed, the work must be repeated, revising the generator and transformer kva ratings in accordance with the deviation noted.

When the analyses are carried through, a power-angle diagram will have been obtained for each line length studied and for each voltage rating studied, such that P_0 is 80 percent of the crest of the diagram. If the loadings of the lines are expressed in per unit of the "natural" or surge-impedance loading, there is little variation in characteristics of lines over a wide range of operating voltages. A curve of delivered power expressed in terms of per-unit surge-impedance loading and plotted as a function of transmission-line length in miles is shown in Fig. 60. The curve is closely applicable in determining transmission-line loadings based on transient stability for operating voltages between 69 and 500 kv.

As an example, the curve indicates that a 450-mile transmission line can deliver an amount of power equal to 0.69 times the surge-impedance loading. If the operating voltage were 345 kv, the line could deliver $(0.69)(2.5)(345)^2 = 205\ 000$ kw. At 230 kv, the capability of the line would be 91 000 kw. In each case, the delivered power is the value of P_0 obtained in the analyses above less the line loss, and is the deliverable power for rating purposes.

Before it can be considered operable, a system must be stable under steady-state as well as transient conditions.

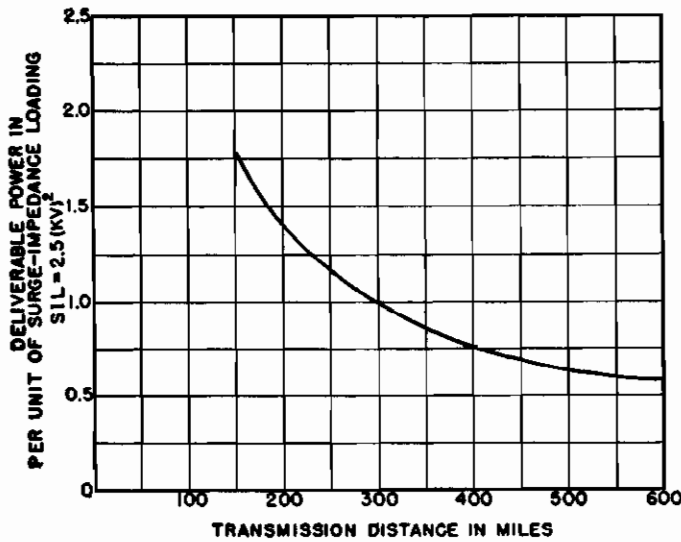

Fig. 60—Permissible loading of straight-away transmission lines as a function of line length in miles for voltages from 69 kv to 500 kv.

The curve of Fig. 60 is based on a criterion of transient stability, and it shows the permissible loading when the criterion is met. These results were examined for steady-state stability and found to be within steady-state limits with satisfactory margin. Therefore, the loadings for various line lengths may be considered acceptable under steady-state and transient criteria.

X. METHODS OF IMPROVING SYSTEM STABILITY†

The effect of various specific factors in the stability problem will be considered from the standpoint of improving system stability. For convenience these factors will be considered under the principal headings of "Power-System Layout," "Power-System Operation," and "Characteristics of Apparatus." These sections are followed by a discussion of "Other Methods of Increasing the Practical Operating Power Limits."

45. Power-System Layout

Power-system layouts should usually be analyzed from the stability point of view for the three circuit conditions associated with the transient, viz., before, during, and after the transient. Some features of layout are beneficial to stability for all three circuit conditions while other features are beneficial for one condition and detrimental for another; hence, the many features of power-system layout must be weighed individually in connection with each circuit condition.

Series Reactance—The most obvious method of increasing the stability limit of a system is to reduce the

†Part X is based largely upon the "First Report of Power System Stability," A.I.E.E. Subcommittee on Interconnection and Stability Factors, R. D. Evans, Chairman, *A.I.E.E. Transactions*, pp. 261-282, Feb. 1937. It includes some changes and additions due to progress in the art. For the practices summarized in this report see App., Table 3.

transfer reactance or "through reactance" between synchronous machines, as this directly increases the synchronizing power that can be interchanged between them. The reactance of a transmission line can be decreased by reducing the conductor spacing. Usually, however, the spacing is controlled by other features, such as lightning protection, and minimum clearance to prevent an arc from one phase involving another phase. Another method of reducing line reactance is to increase the conductor diameter by using material of low conductivity or by hollow cores. Usually, however, the characteristics of the conductors are fixed by economic conditions quite apart from stability. The use of bundle conductors (Chap. 3, Sec. 10) is an effective means of reducing series reactance.

The transformer reactance should be kept as low as practical. While some reduction from normal reactance, as shown in Chap. 5, is permissible, economic considerations usually prevent much departure from the lowest value obtainable without increasing the cost.

The series capacitor provides another means for decreasing the "series" reactance of transmission systems. However, at times of system faults the current through the capacitor raises the voltage across it to several times normal. To protect against such overvoltages, two procedures are available: (1) relatively expensive capacitors capable of withstanding the abnormal voltage can be used, (2) the capacitors can be designed for the maximum voltages produced under normal circuit conditions and provided with a device for short-circuiting it during the excess-current condition. When series capacitors are used with short-circuiting means, they are ineffective during the fault condition. However, when high-speed circuit breakers are used, the fault condition is promptly relieved and the advantage of low series reactance is obtained for the subsequent part of the oscillation. The application of series capacitors is discussed in Chap. 8.

Transmission-circuit reactance drops are commonly reduced by adding parallel lines or increasing the circuit voltage. Comparisons at times are made between several low-voltage circuits and a few high-voltage circuits. Obviously, the fewer the number of circuits the greater is the reduction in the power limit of the layout when one circuit is switched out.

Bussing Arrangements—The method of paralleling lines or apparatus, or the bussing arrangements, can have an important bearing on system stability. High-voltage busses at the ends of transmission lines or at intermediate points result in smaller change in the transfer reactance at the time of the isolation of a faulted transmission-line section than for the case with low-voltage busses, since the latter involves the loss not only of the line but also of the associated transformers. During the faulted condition the shock to the system is greater with the high-voltage bus than with the low-voltage bus. It is impossible to generalize on the relative merits of high- and low-voltage bus arrangements because the result in any particular case is dependent upon the relative reactance proportions of the system, the type and duration of the fault, and the character of system grounding. The results of calculations on a particular system with alternative bus arrangements

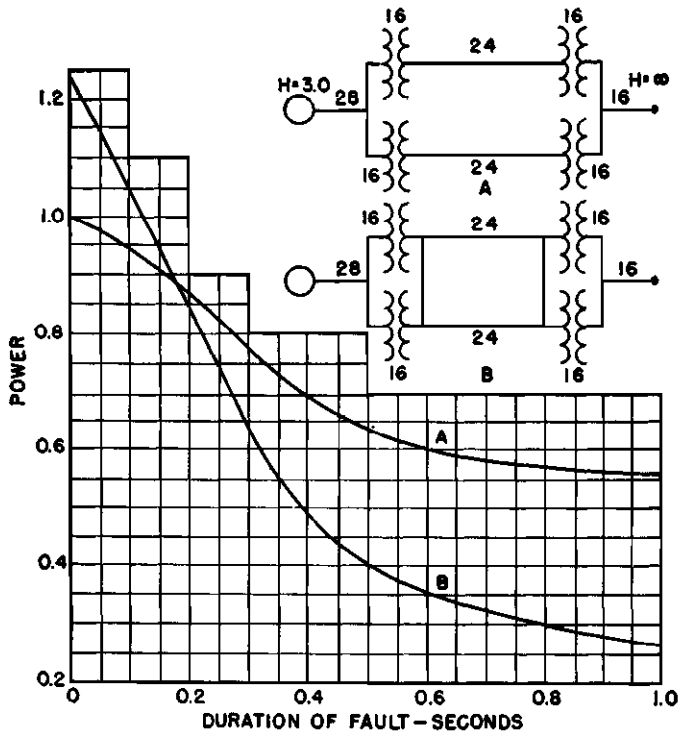

Fig. 61—Effect of bussing arrangement on stability limits; double line-to-ground fault at sending end.

A—Low voltage bussing.
B—High voltage bussing.

System reactance shown in percent; inertia constant H = kilowatt-seconds/kilovolt-ampere.

are illustrated in Fig. 61. For faults of short duration the change in the transfer reactance of the system after the fault is cleared is more important than the shock to the system during the fault, and, therefore, the high-voltage bus arrangement gives higher stability limits; for faults

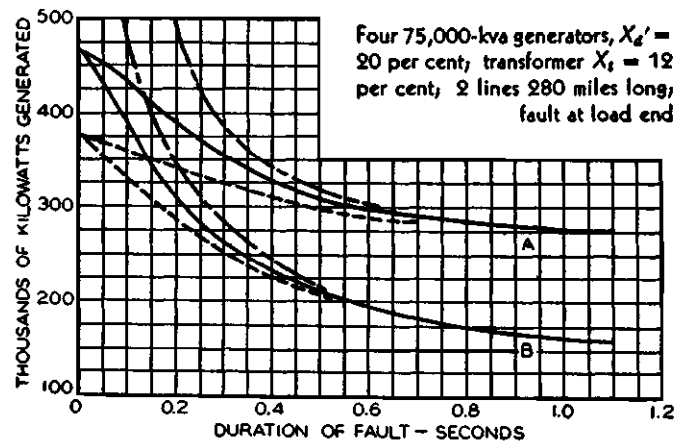

Fig. 62—Effect of number of switching stations on stability limit.

A—Single line-to-ground fault.
B—Double line-to-ground fault.
---One intermediate station.
- · - · -Two intermediate stations.
····Bus fault cleared with no loss of line.

of longer duration, the shock to the system is more important and the converse is true regarding layout. By using reactors between the high-voltage busses, it is possible to obtain characteristics intermediate between those for high- and low-voltage bussing, approaching either to any degree desired. The results of the study in a particular case of the effect of varying the number of intermediate switching stations on a long transmission line is shown in Fig. 62.

Another method of bussing is incorporated in the scheme known as "synchronizing at the load"¹¹ as applied to metropolitan-type power systems. By metropolitan system is meant the type of system that exists in large cities and is characterized by large turbine-generating units located close together with short transmission distances. With this scheme there are no direct ties between synchronous-machine busses but only indirect ties through a multiplicity of connections at secondary or utilization voltages. With this layout secondary faults do not have a severe effect upon the system and can be "burned clear." Faults on a particular generator bus require disconnection of that unit, but the remaining units accelerate or decelerate together. Of course, the shock to the connected load is decreased as the speed of circuit breakers and relays is increased.

While "synchronizing at the load" was developed for supplying power to metropolitan areas, the underlying general principle has been applied in connection with certain long-distance transmission projects, notably for the Conowingo-Philadelphia²⁴ and Hoover-Chino lines. The modification of the scheme for this application is characterized by the bussing of the system only on the lower-voltage side at the receiving end. On such a system transmission-line faults result in disconnection of an entire unit consisting of a generator, sending transformer, transmission line and receiving transformers. Since the plan of operation contemplates the disconnection of a unit for every fault on the transmission line or its associated apparatus, each circuit can be operated relatively close to its steady-state power limit. Faults on the lower-voltage bus at the receiving end or on the connecting lines will probably be controlling in determining the transient power limits. These connections are similar to those employed on early systems where transmission lines from separate hydroelectric plants were paralleled only at the receiver.

The same general principles of system connection have also been employed in circuits with two-winding generators and four-winding transformers.¹³⁻¹⁷ These schemes improve stability by limiting the severity of short circuit and by distributing the stress among the remaining units. An important advantage of the double-winding generator arises from the fact that in the event of a fault on one winding the remaining winding can carry load and thus minimize the disturbance to the system that would result from the disconnection of the faulted machine and the readjustment of load on the remaining units.

Another method of bussing is the "loose-linked" system,¹⁴ which consists of several power areas normally operated in parallel, being loosely connected for purposes of synchronizing and interchange of power. The plan of

operation is such that in any power area the largest generator or the interlinking ties can be lost without leaving in any area a load greater than the ability to carry it. In the event of a serious disturbance within a power area, that area including its load and sources of power is isolated from other power areas by opening of the ties at appropriate points.

Grounding—In America it is common practice on high-voltage systems to ground the neutral solidly and on moderate-voltage systems to ground the neutral solidly or through a resistance. For some types of high-voltage systems there has been recently an increased tendency to provide transformers with sufficient insulation in the neutral to permit grounding through a moderate impedance. The ground-fault neutralizer scheme in which the system is grounded through reactors tuned with the system capacitance to ground at fundamental frequency, has not been generally accepted, although it is being used successfully in an increasing number of locations. These schemes also have arc-suppression characteristics as discussed in Sec. 49. The introduction of neutral impedances, by limiting the severity of the fault, increases the stability limits. Two effects may be present: if the impedance is a pure reactance, the current is limited and the synchronizing power is increased thereby; if the impedance is a resistance, power is absorbed in it

and the generator output increases and its acceleration is correspondingly retarded. The effects of these factors are illustrated in Fig. 63, which shows the stability limit as a function of the duration of the fault and the connection of the neutral impedance for single and double line-to-ground faults on the high-voltage line at both the sending and receiving ends of a typical system. These curves show that neutral impedances, preferably resistance at the sending end and reactance at the receiving end,* help maintain stability. The importance of the method of grounding in relation to power-system stability has been minimized by the development of high-speed breakers and relays and the trend in the direction of basing system design upon the more severe types of faults. In general, however, factors such as lightning protection and relaying, and cost affected by insulation and interconnection with other systems, rather than stability, determine particular methods of grounding to be employed. For further discussion, refer to Chap. 19.

46. Power-System Operation

Power-system operation is often as great a factor to insure system stability as proper system design. The allocation of generator capacity in relation to the system-load and circuit conditions is of considerable importance, particularly under abnormal circuit conditions. The stability problem can be accentuated by interconnection and is complicated by the related problems that arise when frequency control is applied or when the location of generating capacity is determined by maximum-economy considerations rather than system-load requirements.

Most power systems are designed for adequate stability under steady-state conditions. There are, however, many systems where a stability problem is encountered as a result of a fault, and for economic reasons it is not always possible to eliminate this condition. Observance of certain basic operating principles will prevent exceeding the steady-state limits and insure prompt recovery following a fault.

Adequate spinning-reserve capacity either in the form of spare generators or reliable interconnections, must be available in each load area to insure a steady-state limit in excess of the power and reactive kva requirements in event of loss of a generating unit or loss of excitation.

The method of supplying excitation to a system has an important effect on stability. The choice of the bus voltages to be maintained or compensated for load and circuit changes, can be of great importance. Voltage regulators tend to improve stability conditions by automatically changing the excitation in accordance with loads. They are capable of sustaining system voltages within safe limits even in the event of the loss of excitation on one of the units. They also tend to keep the field strength of individual units within reasonable limits thereby preventing the cascading of trouble following the initial disturbance. Other characteristics of excitation systems and their control in relation to stability are discussed in Sec. 47.

The increasing use of automatic devices, such as refrigerators, water heaters, water pumps, etc., which are

*This particular arrangement is used on the 15-Mile Falls Development.^{20,21}

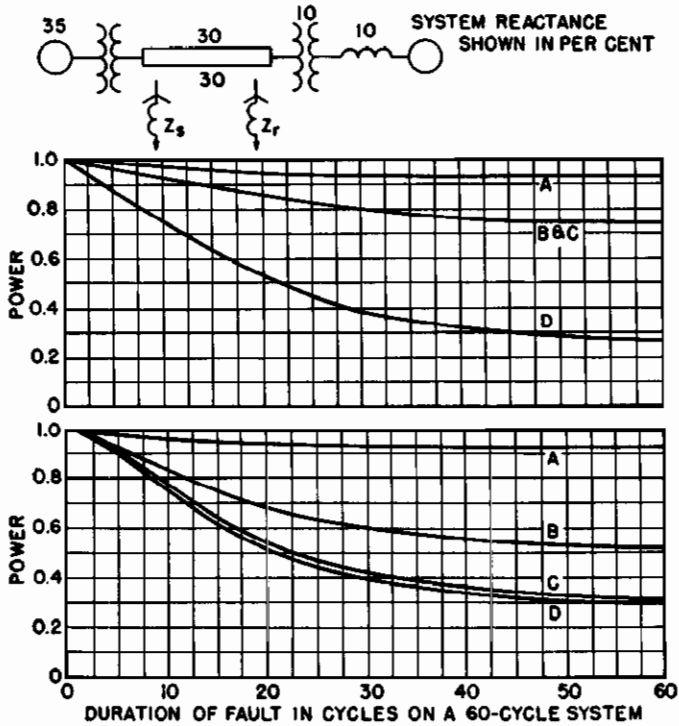

Fig. 63—Effect of grounding method upon system stability.

Curve	Z_s , Percent	Z_r , Percent
A—Single line-to-ground.....	13	+j10
B—Double line-to-ground.....	13	+j10
C—Double line-to-ground.....	13	0
D—Double line-to-ground.....	0	0

Upper set of curves for fault on high-voltage bus at sending end.
Lower set of curves for fault on high-voltage bus at receiving end.

not locked out following an outage, results in extremely high power demands when service is restored. A recent outage resulted in a peak following restoration of service which was approximately 45 percent more than the load interrupted. Provision must be made for excess generator capacity for a short period when service is resumed, or the service must be restored slowly to limit the temporary load until its diversity becomes normal. The spinning-reserve capacity for best results should be distributed in the several load areas so that its availability is not restricted by tie-line limitations.

The use of automatic load control on interconnecting tie lines has increased the practical load limits of these lines by preventing the usual drift in the tie-line load, thereby holding the scheduled load well below the tie-line limits. These devices are of no value for transient conditions.

Coordination of stability studies and operating instructions for abnormal conditions is a matter of considerable importance for insuring the maintenance of stability or avoidance of service interruption.

When synchronism is lost on a system having synchronous condensers, a state of equilibrium is sometimes reached under which the system will neither accelerate nor retard until conditions are changed by switching operations, or by removal of synchronous condensers. The removal of synchronous condensers, either manually or by underspeed relays, relieves the system of superposed low-frequency currents caused by condenser excitation, and permits a more rapid restoration of service.

47. Characteristics of Apparatus

Synchronous Machines—The characteristics of synchronous machines that are important from the standpoint of stability are substantially the same in the synchronous generator, motor, or condenser. In general, the characteristics of generators are of much more importance because they constitute the largest percentage of the total connected synchronous capacity and because they have such an important bearing on the overall system angles. The following discussion will be given in terms of synchronous generators with the understanding that for synchronous condensers and motors the general features are the same but generally of relatively less importance.

The best criterion of generator performance under conditions in which system stability is determined chiefly by the transient characteristics is its transient reactance or more definitely, the direct-axis component commonly designated as x_d' , as discussed in Secs. 15 and 16. The effects of decreasing the transient reactance of generators upon increasing the stability limits for a particular study are shown in the curve of Fig. 64. The normal value of the constants of various types of synchronous machines are shown in Table 4 of Chap. 6. The effect of decreasing the transient reactance upon the cost of a machine is indicated in a general way by the curves of Fig. 65. In a considerable number of installations, beginning with Conowingo²⁴ and including Hoover Dam,³¹ it has been found desirable to employ generators of less than normal transient reactance.

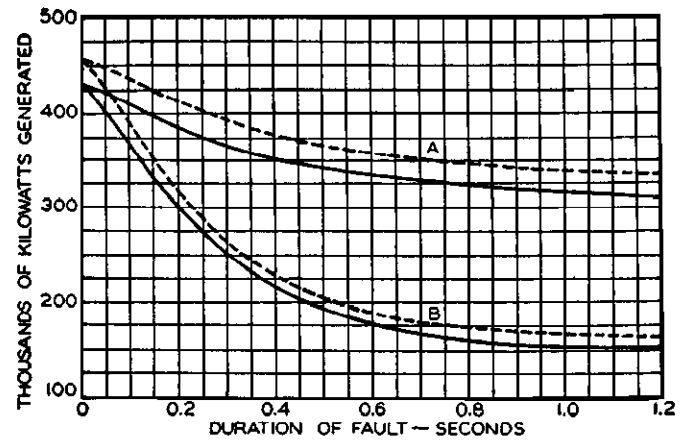

Fig. 64—Effect of generator reactance upon stability.

A—Single line-to-ground fault.

B—Double line-to-ground fault.

Solid curves for generator transient reactance x_d' = 30 percent; broken curves for x_d' = 21 percent.

Fault at load end; 2 lines, 280 miles, 3 sections; transformer x_t = 10 percent; 4-70 000-kva generators.

For most present-day systems, steady-state stability limits are unimportant. With increased application of faster breakers and relays and the logical attempt to increase the load carried on these circuits, the steady-state stability limitations will become increasingly important. A useful criterion of machine performance with reference to steady-state stability is the machine short-circuit ratio. The short-circuit ratio is a direct measure of the relative pull-out torques for generators with the same per-unit excitation. However, for the same current and power factor on machines of different short-circuit ratios, the relative short-circuit ratios do not give a direct measure of the relative pull-out torques, because the excitations are not equal. In general, the higher the short-circuit ratio, the higher is the pull-out torque. It is the one constant of the generator that comes closest to being a direct index of pull-out torque.

Short-circuit ratio is also of value as an approximate measure of the size of machine. Its use for this purpose depends upon the fact that to a considerable extent any reduction of reactance in a machine below its normal value is obtained by derating a larger machine and modi-

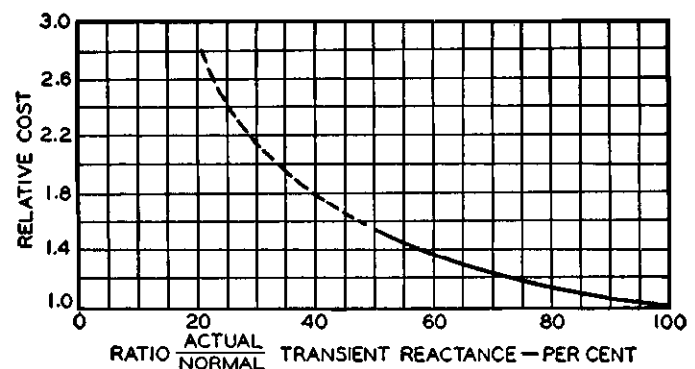

Fig. 65—Approximate cost of decreasing the transient reactance of salient-pole synchronous generators.

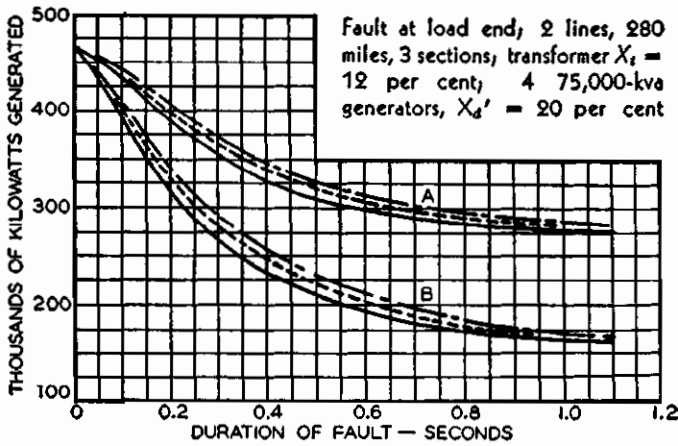

Fig. 66—Effect of generator inertia upon system stability.

- A—Single line-to-ground fault.
- B—Double line-to-ground fault.
- Minimum WR^2 (31×10^9 lbs-ft²).
- - - 50 percent additional WR^2 .
- - - 100 percent additional WR^2 .

fyng the current-carrying parts to meet the reduced values.

The inertia of a synchronous generator or motor is also a factor in the stability problem since it affects the natural period of system oscillation, or the time required to reach a point beyond which recovery would be impossible. Figure 66 shows the results of calculations for various values of generator inertia upon the stability limits for a particular system. The range of inertia constants for various types of synchronous machines is shown in Table 8, and more specific data based on speed and kva are given in Chap. 6, Part XIII. The cost of adding inertia to large vertical waterwheel generators increases about one-fifth as fast as the inertia. In a few cases, including Hoover Dam, where calculations have indicated that a particular system would operate relatively close to the stability limits, generators of higher than normal inertia have been installed.

TABLE 8—TYPICAL INERTIA CONSTANTS OF SYNCHRONOUS MACHINES*

Type of Machine	Inertia Constant H Stored Energy in Kw-sec per Kva**
Turbine Generator	
Condensing 1800 rpm	9-6
3600 rpm	7-4
Non-condensing 3600 rpm	4-3
Waterwheel Generator	
Slow-speed (<200 rpm)	2-3
High-speed (>200 rpm)	2-4
Synchronous Condenser***	
Large	1.25
Small	1.00
Synchronous Motor with Load	2.00
varies from 1.0 to 5.0 and higher for heavy flywheels	

*For more specific figures, see Fig. 75 of Chap. 6.

**Where range is given, the first figure applies to the smaller kva sizes.

***Hydrogen-cooled, 25 percent less.

The severity of unsymmetrical system faults is affected by the negative-sequence impedance of the connected machines. Amortisseurs or damper windings affect both the real and reactive components of this impedance. Machines without damper windings possess the highest negative-sequence reactance, but machines with high-resistance damper windings possess the highest negative-sequence resistance. The curves of Fig. 67 show the combined effect of the damper material upon the stability limit of a typical system for line-to-line and double line-to-ground faults on the high-voltage bus at the generator end. The improvement with high-resistance dampers is quite appreciable for long fault duration, but for the duration that can be obtained at present with high-speed breakers, the improvement is very much less. In the event of system oscillations low-resistance copper damper windings produce the greatest damping of the mechanical movement. However, this effect is unimportant during and following a system fault except in the rather rare case in which the system is so constituted that pullout takes place as a result of compound oscillations following a disturbance. To obtain the partial advantage of the high loss associated with high-resistance dampers at times of

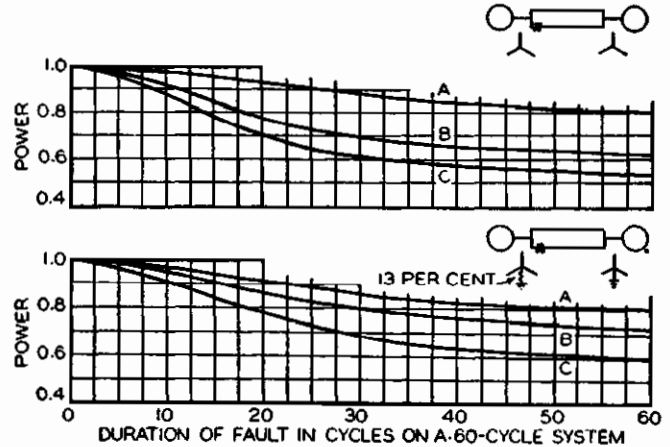

Fig. 67—Effect of damper-winding material upon stability limits.

System Same as Fig. 63-C.

- A—High resistance. B—No dampers. C—Copper.
- Upper curves for line-to-line fault.
- Lower curves for double line-to-ground fault.

unbalanced faults and the damping of oscillations associated with low-resistance dampers, the generators of one installation, i.e., 15-Mile Falls,^{19,20} were supplied with a special type of damper winding which consists of a double-cage arrangement in which the outer row of bars is made of high-resistance material and the inner row of bars is made of a low-resistance material imbedded in the iron. For the double frequency associated with negative-sequence, the copper bars possess a high reactance and, therefore, force most of the current through the high-resistance bars. For the low frequency associated with the system oscillations, the current varies inversely with the resistance of the damper bars and allows most of the current to flow through the copper winding. The benefit from high-resistance damper windings is decreased as the fault duration is de-

creased by the use of faster breakers and relays. Damper windings also have characteristics which tend to suppress spontaneous hunting and to reduce system overvoltages and recovery rates arising from short circuits; in these respects, low-resistance copper dampers are somewhat more effective than high-resistance dampers.

With the increase in size of generator units, the greater concentration of power on a single bus has increased the duty on circuit breakers and the area affected by a fault on or near the bus. These effects can be minimized by the use of the two-winding generator^{13,17} in which the two armature windings are connected only through their mutual coupling which can be controlled by suitable design. Generators of this character lend themselves to incorporation as units in the system layout known as "synchronizing at the load" or its variations as described previously.

Excitation Systems—Control of the excitation system on synchronous machines provides a means for improving stability limits for transient conditions and also for steady-state conditions. Excitation systems that are effective from the standpoint of stability are commonly termed quick-response excitation systems, the principal features of which are:

1. Exciter of quick response, i.e., of high rate of build-up and of high "ceiling" voltage.
2. A reliable source of power to the exciter.
3. Quick-responding regulator.

Exciter response is the rate of build-up or build-down of the main-exciter voltage when a change in this voltage is demanded by the action of the voltage regulator. The response of the exciter was formerly expressed in "volts per second" corresponding to the average value effective through an interval of one-half second beginning at rated-load field voltage. This rate is standardized as the numerical value obtained, called the *response ratio*, by dividing the average value of volts per second in the same time interval by the rated-load field voltage. The method of determining exciter response is illustrated and formal definitions are given in Chap. 7. Exciter response ratio of 0.5 on the per unit basis just described is now standard; faster response up to 2.0 is regularly available at a small additional cost, and still faster response can be provided.

The characteristics which an excitation system must have to obtain the benefits of quick response include a high-ceiling voltage as well as a high rate of build-up. The ceiling voltage of an exciter varies through quite a wide range depending upon the particular design. The actual value in a particular case is adjusted so as to give the desired response through the half-second interval. Usually the ceiling voltage will be considerably more than 50 percent above the normal exciter voltage for the maximum rated load.

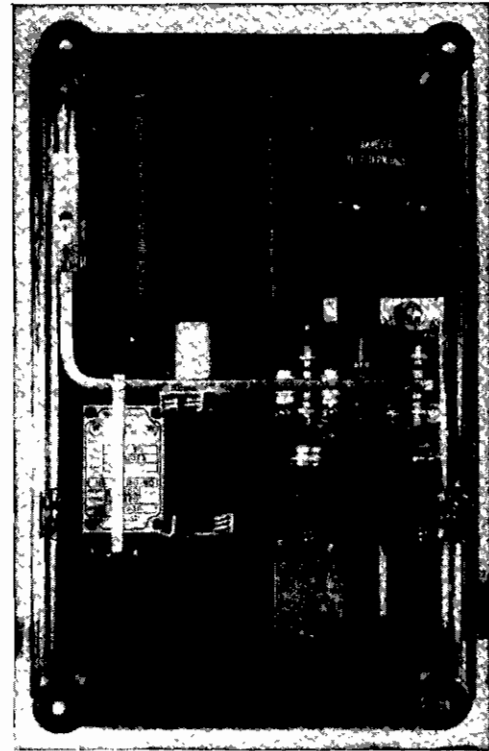

(a)

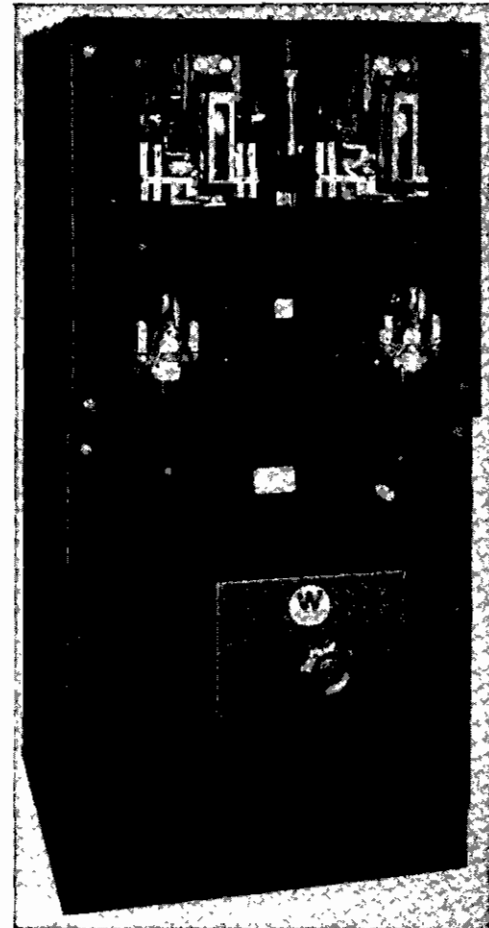

(b)

Fig. 68—Typical voltage regulator for control of the quick-response excitation system for a large waterwheel generator. Type BJ indirect-acting exciter-rheostatic voltage regulator.

- (a) Main control element in projection-type case with glass cover.
- (b) Cubicle-type assembly of regulator-contactor panel and plate-type motor-operated main-exciter field rheostat.

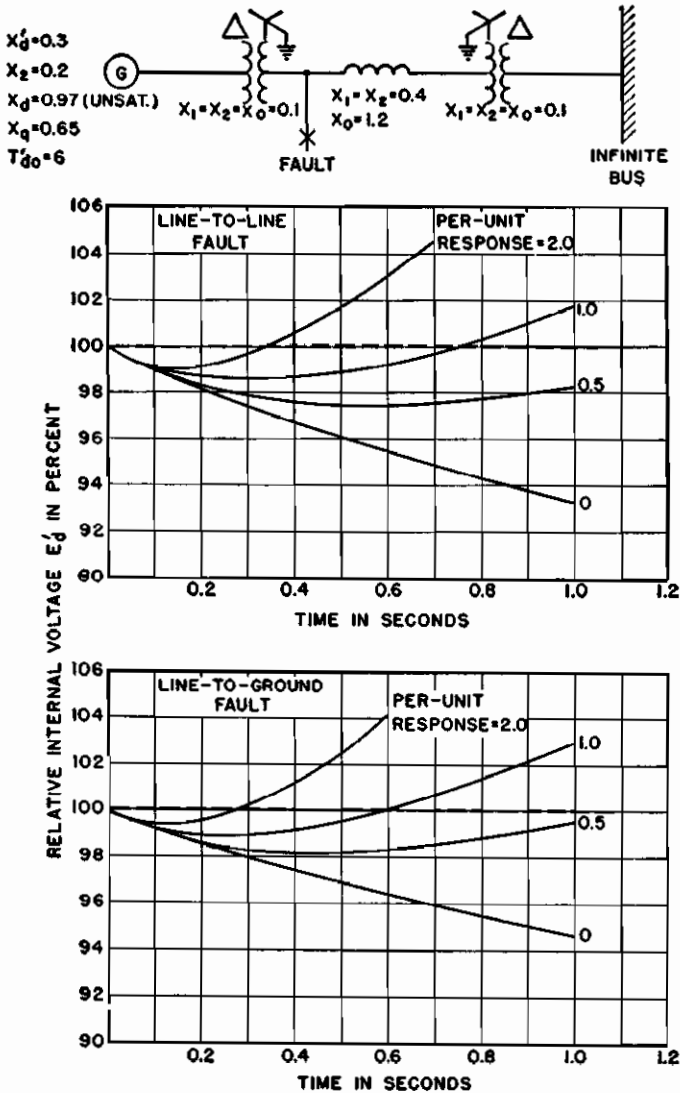

Fig. 70—The effect of different speeds of exciter response on the internal voltage of a waterwheel generator with damper windings. System shown in the insert is subjected to line-to-line and line-to-ground faults at sending end. The ratios of ceiling to normal exciter voltage are 2.2, 1.6 and 1.6 for per-unit exciter responses of 2.0, 1.0 and 0.5, respectively.

the length of time necessary for some readjustment of the system. Ordinarily the speed of exciter response is of secondary importance in comparison with the exciter range. However, quick-response excitation systems normally possess the essential exciter range and whatever advantage that resides in the quicker response.

Quick-response excitation systems also provide means for increasing the steady-state stability limits by facilitating operation in the zone of dynamic stability as discussed in Sec. 17. In a few cases it appears probable that some beneficial action from regulators in the region of dynamic stability is required to explain the absence of pullouts. In general, however, since the steady-state limits are higher than the transient limits, the favorable characteristics of a voltage regulator to increase the steady-state limits has been without real significance. There is also the question as to the desirability of having the opera-

tion of a station at its rated load being dependent upon the functioning of a regulator. Consequently, the choice of regulator has been determined from its performance under transient conditions and its maintenance under ordinary operation.

High-Speed Circuit Breakers and Relays—The duration of a fault condition has a very important effect on the stability of a system. The fault condition reduces synchronizing power, (1) directly by altering the equivalent-circuit constants and (2) indirectly by reducing the effective machine voltages through the demagnetizing action of fault currents. The stability limits as affected by the speed of breaker and relay operation vary through a wide range from (1) the limits corresponding to sustained faults to (2) a mere switching operation assuming extremely fast fault isolation. High-speed circuit breakers and relays are capable of covering most of this range and thus constitute a very important measure for increasing the stability limits, particularly for transmission systems.¹⁶

The relation between the speed of fault isolation and the transient-stability limits for a typical transmission system is indicated in Fig. 71, which also gives the impedance constants of the various system elements. The system is assumed to be subjected to a fault on one line near the high-voltage bus at the sending end and to be cleared by the opening of the two breakers simultaneously. The curves assume waterwheel-type generators, and receiving-end machines of relatively high inertia. The calculations were made for the four different types of faults shown on the curves, which are plotted in terms of the time required for the isolation of the fault and the ratio of the power that can be transmitted to the power limit corresponding to the

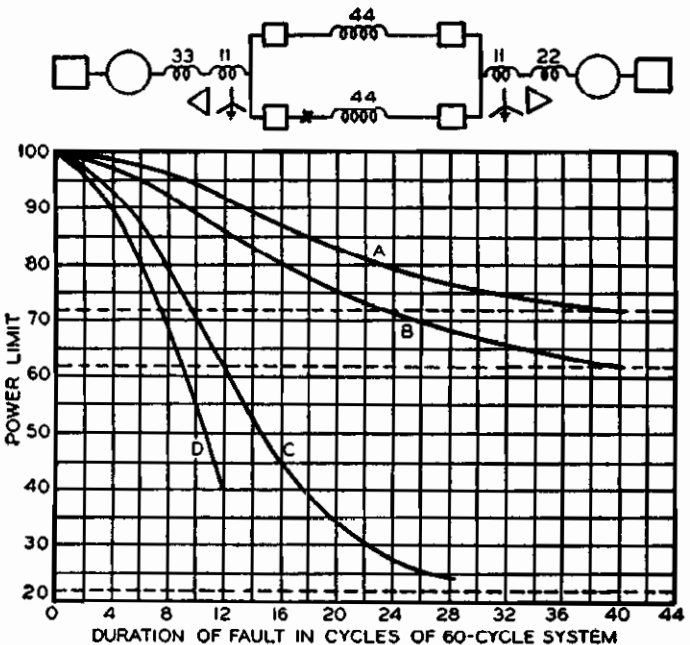

Fig. 71—Effect of duration of fault on power limits for different kinds of faults.

A—Single line-to-ground fault. C—Double line-to-ground fault.
 B—Line-to-line fault. D—Three-phase fault.
 System reactance shown in percent.

switching out of one section of the transmission line. The dotted lines show the loads which can be carried with sustained short circuits of the various types assuming quick-response excitation systems capable of preventing demagnetization of the machines.

The curves in Fig. 71 apply to a system subjected to a fault at the sending end. The relative stability conditions for the fault at sending and receiving ends of a somewhat different system were given in Fig. 63 which has been discussed previously in connection with the use of neutral impedances. A moderate value of neutral resistance at the sending end can make a fault at that end on a grounded-neutral system relatively less severe than a fault at the receiver. However, the gains in stability due to the use of high-speed circuit breakers are of the same order for faults at the sending or receiving ends of the transmission system.

On metropolitan-type systems the permissible time for isolating the fault will be relatively longer than for transmission systems since the latter are usually operated closer to the stability limits. Thus in the metropolitan systems it is possible to introduce reactance in the system in such a way as to limit the duty on circuit breakers. This problem can conveniently be studied by the short-cut method²³ discussed in detail in Part VIII.

The curves used in this method indicate that by taking advantage of the faster speeds made possible by the recent developments of circuit breakers, increased amounts of reactance can be introduced in the system either to reduce the duty on circuit breakers or to increase the continuity of power supply or reliability of the service to the customer.

The speed of circuit breakers and relays in relation to power-system stability can conveniently be analyzed under three headings as follows:

1. Conventional or slow-speed breakers and relays for fault isolation.
2. High-speed breakers and relays capable of isolating fault in time to improve stability limit.
3. High-speed breakers and relays with reclosure in time to improve stability limit.

The curves of Fig. 71 show that conventional slow-speed circuit breakers and relays of the type commonly in use prior to 1929 were so slow from the stability point of view that the limits corresponded to sustained faults. The power limit for the three-phase fault is almost negligible with the conventional slow-speed breakers formerly in use. The benefits which arise from the use of high-speed circuit breakers and relays in maintaining stability depend upon isolating the fault in an interval of time which is short in respect to the period of system oscillation. The preceding discussion has been based on the isolation of the fault in a single step. For sequential operation the time permissible for each breaker will be less than that shown but need not be reduced to half value. This is, of course, due to the fact that the stability conditions are generally much improved upon the operation of the first circuit breaker.

The need for high-speed circuit breakers has brought about the development and general use of circuit breakers with shorter operating times. At present, standard breakers 115 kv and above have an operating time of 5 cycles, except 230-kv standard breakers, which have an operating time of 3 cycles. Three-cycle breakers cost about five

percent more than the standard five-cycle breakers for the same rating. The standard operating time for 69 kv and below is 8 cycles. It is interesting to note that at the time this book was originally published (1942) 8-cycle breakers were standard up to 230 kv.

For composite systems with long-transmission lines from a source of power and for interconnecting lines between various parts of the receiver, system studies will frequently show the desirability of using high-speed circuit breakers and relays in order to increase the stability limits. In a number of such cases it will be important to extend the application of the high-speed breakers to interconnecting lines of the receiver system. Otherwise, the stability limits are determined not by faults on the main transmission line but by faults on the receiving system, even though it is operating at lower voltage with transformers between it and the transmission line.

This development in the speed of circuit breakers has brought about important changes in the relaying of transmission lines. With fast circuit breakers it is no longer feasible to contemplate relay-operating times of one-quarter second to three seconds or the use of time intervals as the basis of discrimination. This has led to the use of distance or current-balance types of relays which are capable of simultaneous action for the middle section of a transmission line with high-speed sequential tripping for the end sections.

In cases where the transmission system is operated relatively close to the stability limits there is considerable advantage in providing simultaneous breaker operation. In general, such relay operation can be obtained by fundamental-frequency relays operating in conjunction with a signal transmitted by pilot wires or carrier current between the ends of the line section. This has brought about an important development in the application of high-speed relaying with superposed carrier-frequency. The relaying quantity to be transmitted by carrier frequency was selected initially as some electrical indication, such as direction of the power flow, but more recently as the position of various fundamental-frequency relays which indicate the existence of a fault on the system within predetermined zones. The carrier-current and pilot-wire relay systems also provide opportunity for including relay measures for the prevention of undesired breaker operation in the event that the system does pull out of step. Reference should be made to Chap. 11 for further information on circuit-breaker and relay applications.

Reclosing Circuit Breaker—Reclosing circuit breakers provide a means for carrying one step further the advantages possible from high-speed fault clearing. For lower-voltage systems and feeder circuits, automatic reclosing breakers make it possible to maintain the stability of a system with induction-motor load. Disconnection of the source is required for the suppression of the arc in the fault, but the total time required for disconnection and for reclosure should be made sufficiently short as to prevent pullout of induction motors. Where synchronous machines can maintain the arc, it is necessary to isolate the affected line and to reconnect it in a period of time that is relatively short with respect to the period of system oscillation if stability is to be maintained.²⁶⁻²⁴ Hence, if automatic re-

closing breakers are considered for maintaining the stability on a transmission system, it becomes a practical necessity to use carrier-current or pilot-wire relaying. The existence of multiple or repetitive lightning discharges may constitute an important factor in limiting the application of reclosing breakers for maintaining stability.

The selection of the operating speed required of high-speed reclosing breakers is dependent upon a compromise between two conflicting factors. One of these is the maximum permissible time between the inception of the fault and the final reclosure as determined by the power-system load and synchronizing-power conditions. The other is the de-ionization time, the minimum time that must be allowed in order to be reasonably sure that the arc will not reignite and thus create a second fault condition. In many cases where high-speed reclosing is desired, there is sufficient time to permit successful application.

The de-ionization time depends upon the circuit voltage, the conductor spacing, the fault current, and weather conditions. Furthermore, the reestablishment of the arc after an interval is a matter of probability and perhaps twenty tests may be required to establish a single point on a 95-percent probability curve for a single combination of circuit voltage, fault current, conductor spacing, and weather conditions. For these conditions the available test data on de-ionization time, although covering several hundred individual tests, is not considered to cover the field adequately for the purpose of establishing limits. From the available information²⁶ the estimated de-ionization time for successful reclosure is given in Table 9.

TABLE 9—MINIMUM DE-IONIZATION TIME FOR RECLOSING BREAKERS

System Voltage Line-to-Line Kv	Cycles on 60-Cycle Basis	
	95% Probability	75% Probability
23	4	
46	5	3.5
69	6	4
115	8.5	6
138	10	7.5
161	13	10
230	18	14

From the standpoint of maintaining stability, the maximum permissible total time from the inception of the fault to the final reclosure varies over a wide range, depending upon the system, location and severity of the fault, and the type of circuit breaker, that is, whether three-phase as discussed in this paragraph or single-phase as discussed in the next. The permissible reclosure time can be calculated with satisfactory accuracy by methods previously discussed in this chapter, or by reference to the curves²⁶ of Fig. 72. These curves apply to two systems of relatively high inertia connected through a tie line of relatively high reactance. In order to use these curves it is necessary to determine, first, the synchronizing-power limit as determined by the quantity $3\frac{E^2}{X}$ where E is the nominal system voltage line-to-neutral and X is the transfer reactance per phase. The load to be transferred

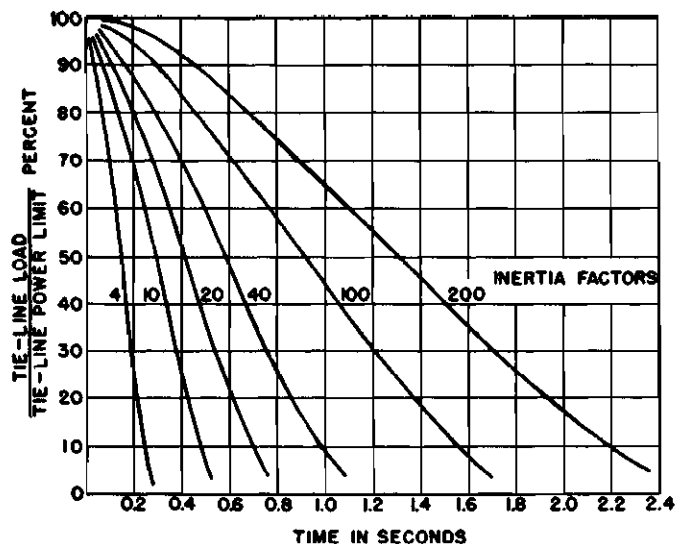

Fig. 72—Permissible time for breaker tripping and reclosure without causing loss of synchronism with gang operated breakers.

over the tie line is then expressed as a percentage of the maximum synchronizing power over the tie line and used as the ordinate of the curve of Fig. 72. If the capacity and inertia constants of the two systems are kva_a , kva_b , and H_a , H_b , then the equivalent inertia constant $H_{eq(a)}$ can be determined from Eq. (37), Sec. 22. The inertia factor to be used in the curves of Fig. 72 is obtained from

$$\text{Inertia Factor} = \frac{H_{eq(a)}kva_a}{TL_{kw}} \quad (66)$$

where TL_{kw} is the tie-line load in kw. Reclosing breakers have been used to improve the stability conditions on a number of 132-kv systems, notably of the American Gas and Electric Company³⁴ and of the West Penn Power Company. The important advantage of reclosing breakers arises from the fact that their use can frequently convert an unstable tie line to one which can be considered as a firm-power source and thus justify a reduction in the connected generating capacity.

Single-Pole Reclosing Breakers—During World War II it became necessary due to increasing demand for power to use single-circuit tie lines between systems to transfer firm blocks of power. Single-pole reclosing breakers have been used successfully in this application. Ground-fault neutralizers are useful in this application, but provide improvement only in the case of single line-to-ground faults, whereas single-pole reclosing breakers improve the stability limits of a single tie line for all types of faults, except three-phase. In this case the operation is that of a gang-operated reclosing breaker.

The advantage of single-pole operation lies in the fact that power can be transferred over the unfaulted phase(s) during the period when the breakers are open to clear the fault. Since most line interruptions do not permanently ground a phase conductor, successful reclosure is obtained in the majority of cases and thus restores the system to its original condition without at any time reducing the power limits to as low a value as would be the case if all three conductors were disconnected.

If single-pole reclosing is to be used, the transformer banks at both ends of the tie line should be grounded solidly or through low values of impedance in order that power may be transferred during the breaker operating period.

A comparison of three-pole and single-pole reclosure has been made for the system shown in the insert of Fig. 73. The result of stability calculations for the two types of reclosure are plotted in Fig. 73 in terms of the per-

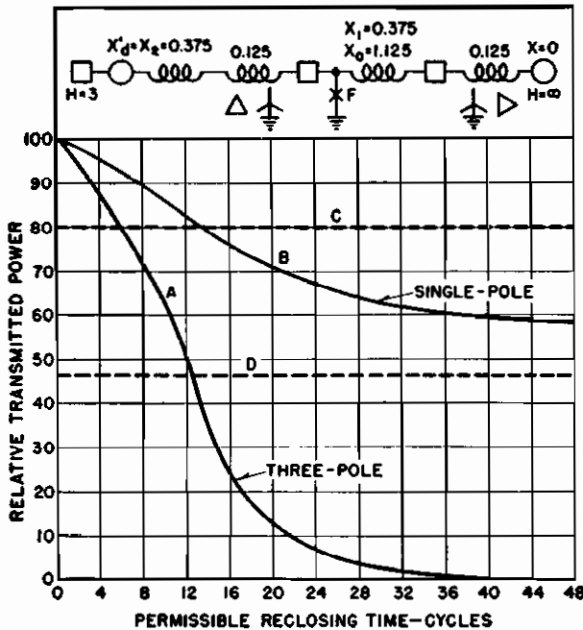

Fig. 73—Comparison of three-pole and single-pole reclosing breakers from standpoint of permissible transmitted power and reclosing time for clearing one line-to-ground fault and maintaining stability for the system shown in the insert.

- A—Three-pole reclosing breaker, 4-cycle opening time.
- B—Single-pole reclosing breaker, 4 to 10-cycle opening time.
- C—Stability limit for system, one phase switched open—system same as insert except for theoretical condition of zero-sequence impedance equal zero—10-cycle opening time.
- D—Stability limit for system, one phase switched open—system same as insert but grounded at fault end only.

missible transmitted loads and reclosure times. The curves show the advantages of single-pole reclosure which can be used (1) to transmit greater power, (2) to provide greater deionizing time, (3) to permit the use of slower-speed breakers for fault clearing or reclosure, or a combination of these three. The power-transferring ability of a system for a sustained one-phase open condition varies with the zero-sequence impedance of the circuit between the limits of (1) infinite impedance which obtains with the ungrounded system, and (2) zero impedance, a theoretical condition which is rarely approached even for solidly-grounded systems. The practical case for grounded systems lies between these two extremes.

The single-pole reclosing breaker is somewhat more expensive than the three-pole breaker because of the three separate mechanisms and the more complicated relay system required.

48. Double Line-to-Ground Fault on Single Tie Line

The transient-stability performance of a single tie line between two systems can be calculated using the step-by-step procedure discussed previously. The only difference between this calculation and the previous examples lies in the fact that the sequence networks must be set up so that the power transferred during the period the breakers are open can be determined.

In calculating a transient-stability problem involving single-pole reclosing, it is convenient to divide the sequence of operations into four steps as follows:

1. Condition before the fault.
2. Condition during the fault.
3. Condition with faulted phase(s) open.
4. Condition after fault (line re-energized).

In setting up the sequence networks for condition 3 it is generally sufficiently accurate to use connections n to r inclusive of Fig. 21, Chap. 2, which assumes equal shunt capacitance on all phases. A more accurate calculation can be made using the method presented in Fig. 22, Chap. 2. Reference 41 gives the sequence-network connections.

Figure 74 presents the results of investigations of over 100 practical solutions.⁴² These curves apply only to double line-to-ground faults and can be used to estimate breaker requirements under proposed operating conditions and also to estimate the transient performance of existing lines.

In the study upon which these curves are based, the sending and receiving systems were assumed to be made up of 1800-rpm, 80-percent power-factor machines operating at full load with necessary excitation. Typical system constants were used. The shunt loads were assumed to be 85-percent power factor. In each case the line regulation was adjusted to ten percent. In certain cases this required synchronous condensers at the receiving end to furnish the necessary reactive kva in excess of the capacity of the receiver generators. The inertia of the condensers is not included in the swing calculations because it is usually found to be negligible.

Conventional a-c network calculator studies were carried through for each principle system chosen until the maximum length of line was determined for which transient stability would be maintained keeping all system elements constant except the line length. These curves give only the minimum reclosing equipment that can be safely applied. Allowance should be made for system growth.

These curves give transient-stability solutions using different types of reclosing equipment. Double line-to-ground faults were used in each case.

To determine the maximum power which could be safely transferred over a tie line, plot the ratio, PS/PR, on the proper "(miles/kv²)PR" curve for the reclosing equipment under consideration. The ordinate of the plotted point is the maximum power which could be safely transferred in per unit, based on receiving-end generation. These curves are not intended as a solution of all problems concerning high-speed reclosing, but are presented merely as a guide. These general curves are calculated to apply specifically to tie lines between systems on which steam turbines predominate. Detailed calculations should be made where

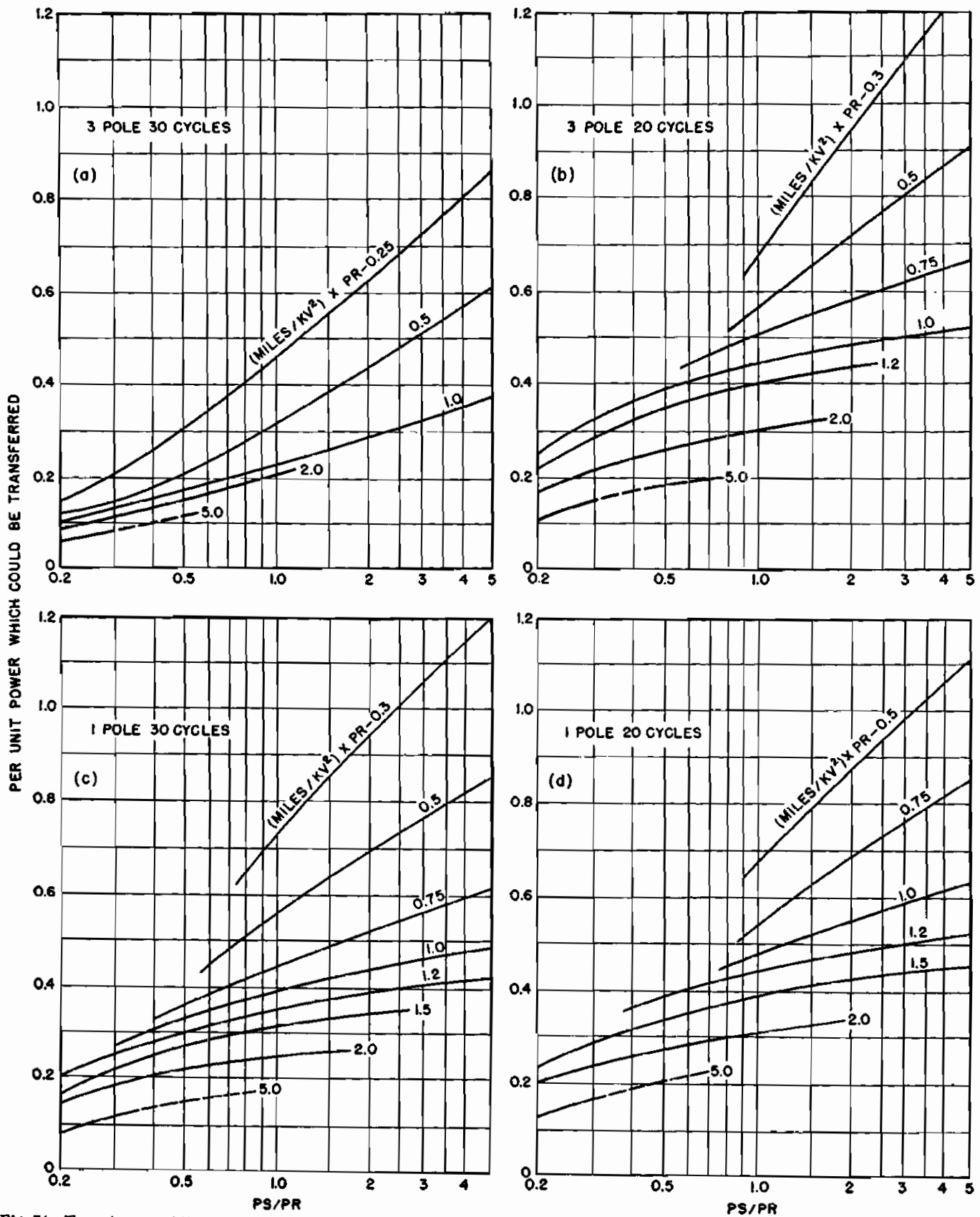

Fig. 74—Transient-stability limits for a double line-to-ground fault on a single tie-line between two systems on which steam turbines predominate.

PS and *PR*=sending and receiving-end generation, in mw, respectively; *KV*=Line-to-line kilovolts.

marginal or unstable conditions are indicated by these curves.

49. Other Methods of Increasing the Practical Operating Power Limits

Flashover-Prevention and Arc-Suppression—A different approach to the problem of improving the practical operating power limit of a system is obtained by the use of flashover-prevention and arc-suppression measures. It is obvious, of course, that a system rarely subjected to faults can be operated relatively close to the stability limits. Consequently, under some conditions it is more advantageous to spend money for minimizing the likelihood of faults than for increasing the capacity of the system to withstand the system disturbances resulting from faults.

The principal cause of flashover on high-voltage lines is lightning. Much has been accomplished during the past fifteen years to minimize flashovers resulting not only from induced strokes but particularly from direct strokes.* Increased transmission-line spacing and increased insulation in the form of insulator strings and wood have generally been adopted. On the higher-voltage lines the use of ground wires is of great value when suitably located with respect to the conductors to be protected. Special efforts have been made to reduce the tower-footing resistance to a relatively low value in order to prevent a flashover of the insulator string as a result of the building up of high potential due to the flow of lightning current through the tower to ground.

The use of the ground wires reduces the zero-sequence impedance of the system and thus increases the severity of the shock resulting from a single or double line-to-ground fault. With the development of high-speed circuit breakers and relays these faults can be cleared promptly; consequently, the use of ground wires results in a gain from the stability point of view by reducing the number of flashovers which overbalances any disadvantage from the standpoint of the shock to the system in case the fault occurs.

The fault-suppression measures have as their object the interruption of the power-arc following a flashover without the necessity for isolating the affected circuit. The use of fused arcing rings or special tube-type protectors in parallel with the insulators permits flashover to take place through a path that insures the subsequent interruption of the power arc. Lightning arresters distributed along the line will accomplish this same general objective. See also Chap. 17.

Arc-suppression devices of the ground-fault neutralizer or Petersen-coil type have received consideration for minimizing circuit outages in connection with multiple-circuit systems of the type in common use and have been used in the single-circuit Hoover-Chino transmission line

*Reference should be made to Chaps. 16 and, particularly, 17.

system. In America, however, little use is made of this type of arc-suppression device as dependence is placed on circuit breakers and relays for automatically isolating a faulty section of line. Circuit-breaker schemes have the merit of suppressing all types of faults that occur on systems regardless of whether they are of the single line-to-ground or more severe types. In addition they permit grounding the system so that the tendency for a single-phase fault to develop into a multi-phase fault is minimized. See also Chap. 19.

High-Voltage D-C, and Low-Frequency A-C Transmission—Low-frequency a-c systems have been proposed frequently for increasing the practical operating stability limits of long-distance transmission systems. More recently d-c transmission has been proposed as a means for avoiding the stability limits since such a system inherently provides a non-synchronous tie. In America, 60-cycle a-c is very generally established for utilization. Consequently, the proposals to use low-frequency a-c and high-voltage d-c transmission schemes have included conversion means at the receiving end. In general, the use of the low-frequency a-c system involves no new problem in apparatus or application so that its use is not hindered on this account, although static apparatus might find application in the field of frequency conversion. In the case of d-c transmission, however, the conversion from a-c generation to the d-c high voltage required for the transmission line involves rectifiers for which there is no comparable operating experience; in the case of the inverters at the receiving end still less work has been done. Considerable interest has been displayed in d-c transmission, but it is still generally considered impractical especially in this country. During the recent war the Germans considered d-c transmission particularly as a means of getting power from Scandinavian peninsula to Germany. D-c transmission can show economic gains over high-voltage a-c transmission only where large blocks of power are to be transferred⁴⁰ for extremely long distances. Even then d-c transmission may not be economical if it is desired to tap off intermediate loads because of the high cost of the terminal equipment. Much work remains to be done before d-c transmission can seriously compete with a-c transmission.

At the present time the limitations in 60-cycle systems, from the standpoint of system stability, are not of sufficient importance as to justify the adoption of either low-frequency a-c or high-voltage d-c transmission^{29,37}. The possible field for d-c transmission depends largely on the practical necessity for transmitting power to considerably greater distances than those used heretofore, on the usefulness of its operating characteristics aside from stability, and on the future development of conversion apparatus. In this connection it should be noted that the series capacitor offers tremendous improvement in a-c transmission at normal frequencies.

STABILITY REFERENCES IN THE ENGLISH LANGUAGE

The "First Report of Power System Stability," item 33, includes a list of 180 articles, which are arranged in chronological order and bear symbols indicating their character.

1. Experimental Analysis of Stability and Power Limitations, by R. D. Evans and R. C. Bergvall, *A.I.E.E. Transactions*, 1924, pp. 39-58. Disc., pp. 71-103.
2. Power System Transients, by V. Bush and R. D. Booth, *A.I.E.E. Transactions*, Feb. 1925, pp. 80-97. Disc., pp. 97-103.
3. Transmission Stability, Analytical Discussion of Some Factors Entering into the Problem, by C. L. Fortescue, *A.I.E.E. Transactions*, Sept. 1925, pp. 984-994. Disc., pp. 994-1003.
4. Practical Aspects of System Stability, by Roy Wilkins, *A.I.E.E. Transactions*, 1926, pp. 41-50. Disc., pp. 80-94.
5. Further Studies of Transmission System Stability, by R. D. Evans and C. F. Wagner, *A.I.E.E. Transactions*, 1926, pp. 51-80. Disc., pp. 80-94.
6. A Mechanical Analogy of the Problem of Transmission Stability, by S. B. Griscom, *The Electric Journal*, May 1926, pp. 230-235.
7. Excitation Systems: Their Influence on Short Circuits and Maximum Power, by R. E. Doherty, *A.I.E.E. Transactions*, July 1928, pp. 944-956. Disc., pp. 969-979.
8. System Stability with Quick-Response Excitation and Voltage Regulators, by J. H. Ashbaugh and H. C. Nycum, *The Electric Journal*, Oct. 1928, pp. 504-509.
9. Transients Due to Short Circuits—A Study of Tests Made on the Southern California Edison 220-Kv System, by R. J. C. Wood, L. F. Hunt, and S. B. Griscom, *A.I.E.E. Transactions*, Jan. 1928, pp. 68-86. Disc., pp. 86-89.
10. Static Stability Limits and the Intermediate Condenser Station, by C. F. Wagner and R. D. Evans, *A.I.E.E. Transactions*, 1928, pp. 94-121. Disc., pp. 121-123.
11. Synchronized at the Load—A Symposium on New York City 60-Cycle Power System Connection, by A. H. Kehoe, S. B. Griscom, H. R. Searing, and G. R. Milne, *A.I.E.E. Transactions*, Oct. 1929, pp. 1079-1100. Disc., pp. 1100-1107.
12. Progress in the Study of System Stability, by I. H. Summers and J. B. McClure, *A.I.E.E. Transactions*, 1930, pp. 132-158. Disc., pp. 159-161.
13. Double Windings for Turbine Alternators, by P. L. Alger, E. H. Freiburghouse, and D. D. Chase, *A.I.E.E. Transactions*, Jan. 1930, pp. 226-238. Disc., pp. 238-244.
14. Fundamental Plan of Power Supply of the Detroit Edison Company, by S. M. Dean, *A.I.E.E. Transactions*, 1930, pp. 597-604. Disc., pp. 612-620.
15. Operating Characteristics of Turbine Governors, by T. E. Purcell and A. P. Hayward, *A.I.E.E. Transactions*, April 1930, pp. 715-719. Disc., pp. 719-722.
16. Selecting Breaker Speeds for Stable Operation, by R. D. Evans and W. A. Lewis, *Electrical World*, Feb. 15, 1930, pp. 336-340.
17. Double-Winding Generators, by R. E. Powers and L. A. Kilgore, *The Electric Journal*, Feb. 1930, pp. 107-111.
18. An Alternating-Current Calculating Board, by H. A. Travers and W. W. Parker, *The Electric Journal*, May 1930, pp. 266-270.
19. Effect of Armature Resistance Upon Hunting of Synchronous Machines, by C. F. Wagner, *A.I.E.E. Transactions*, July 1930, pp. 1011-1024. Disc., pp. 1024-1026.
20. Generator Stability Features—Fifteen Mile Falls Development, by R. Coe and H. R. Stewart, *The Electric Journal*, March 1931, pp. 139-143.
21. Stability Precautions on a 220-Kv System, by H. H. Spencer, *Electrical World*, Aug. 15, 1931, pp. 276-280.
22. Proposed Definitions of Terms Used in Power System Studies—Report of Subject Committee on Definitions, by H. K. Sels, A.I.E.E. paper 32M-2, Abstract *Electrical Engineering*, 1932, p. 106.
23. Generalized Stability Solution for Metropolitan-Type Systems, by S. B. Griscom, W. A. Lewis, and W. R. Ellis, *A.I.E.E. Transactions*, June 1932, pp. 363-372. Disc., pp. 373-374.
24. Stability Experiences with Conowingo Hydro-Electric Plant, by R. A. Hentz and J. W. Jones, *A.I.E.E. Transactions*, June 1932, pp. 375-384. Disc., p. 384.
25. Adjusted Synchronous Reactance and Its Relation to Stability, by H. B. Dwight, *General Electric Review*, Dec. 1932, pp. 609-614.
26. Keeping the Line in Service by Rapid Reclosure, by S. B. Griscom and J. J. Torok, *The Electric Journal*, May 1933, p. 201.
27. *Symmetrical Components*, by C. F. Wagner and R. D. Evans (a book), McGraw-Hill Book Company, New York, 1933.
28. Quick-Response Excitation, by W. A. Lewis, *The Electric Journal*, Aug. 1934, pp. 308-312.
29. Constant Current D-C Transmission, by C. H. Willis, B. D. Bedford, and F. R. Elder, *A.I.E.E. Transactions*, Jan. 1935, pp. 102-108. Disc., Mar. 1935, pp. 327-329, and Apr. 1935, pp. 447-449. Aug. 1935, pp. 882-883.
30. Steady-State Solution of Saturated Circuits, by Sterling Beckwith, *A.I.E.E. Transactions*, July 1935, pp. 728-734.
31. Engineering Features of the Boulder Dam-Los Angeles Line, by E. F. Scattergood, *A.I.E.E. Transactions*, May 1935, pp. 494-512. Disc., 1936, pp. 200-204 and 208.
32. *The Scientific Basis of Illuminating Engineering*, by Parry Moon (a book), McGraw-Hill Book Company, New York, 1936.
33. First Report of Power System Stability: Report of Subcommittee on Interconnection and Stability Factors, by R. D. Evans, Chairman, *A.I.E.E. Transactions*, 1937, pp. 261-282. Disc., May, pp. 632-634 and Sept., p. 1204.
34. Ultra High-Speed Reclosing of High-Voltage Transmission Lines, by Philip Sporn and D. C. Prince, *A.I.E.E. Transactions*, 1937, pp. 81-90 and 100. Disc., p. 1036.
35. Unsymmetrical Short Circuits on Waterwheel Generators Under Capacitive Loading, by C. F. Wagner, *A.I.E.E. Transactions*, 1937, pp. 1385-1395. Disc., 1938, p. 406.
36. *Electric Power Circuits—Theory and Operation—System Stability*, by O. G. C. Dahl (a book), vol. 2, McGraw-Hill Book Company, New York, 1938.
37. D-C Transmission Evolving Slowly, by D. M. Jones, C. H. Willis, M. M. Morrack, and B. D. Bedford, *Electrical World*, Feb. 25, 1939, pp. 41-42.
38. Phase-Angle Control of System Interconnection, by R. E. Pierce and G. W. Hamilton, *A.I.E.E. Transactions*, 1939, pp. 83-91. Disc., p. 92.
39. A Graphical Solution of Transient Stability, by H. H. Skilling and M. H. Yamakawa, *Electrical Engineering*, Nov. 1940, pp. 462-465.
40. Brown Boveri Review, Issue on D.C. Transmission, Vol. XXXII, No. 9.
41. Reclosing of Single Tie Lines Between Systems, by W. W. Parker and H. A. Travers, *A.I.E.E. Transactions*, 1944, pp. 119-122. Disc., p. 472.
42. Reclosing Single-Circuit Tie Lines, by H. N. Muller, Jr. and W. W. Parker, *WESTINGHOUSE ENGINEER*, March 1945, pp. 60-63.

POWER SYSTEM VOLTAGES AND CURRENTS DURING ABNORMAL CONDITIONS

Original Author:
R. L. Witzke

Revised by:
R. L. Witzke

FOR many years it was common practice to base the requirements of system apparatus on normal load conditions and on three-phase short circuits. More or less empirical multiplying factors were sometimes used to predict the probable ground-fault currents from the three-phase fault currents. However, this procedure is unsatisfactory because the relations between three-phase and ground-fault currents vary greatly between systems. In some systems the current for a single line-to-ground fault is less than normal load current, whereas, in other systems, or at other locations in the same systems, the current for a single line-to-ground fault is larger than the three-phase fault current. The analysis of power systems by symmetrical components¹ (see Chap. 2) has made possible the accurate calculation of fault currents and voltages for unsymmetrical faults directly from system constants.

Under many conditions the voltages present on a power system may be higher than those calculated for steady-state conditions. These higher voltages are usually of a transient nature and exist during the transition from one steady-state condition to another. Transient voltages can be produced by simple circuit changes such as the opening of a circuit breaker or the grounding of a conductor, or they can be produced by an intermittent arc in a circuit breaker or in a fault. Usually the higher voltages are associated with intermittent arcs rather than with simple circuit changes without arcing. Most transient voltages are not of large magnitude but may still be important because of their effect on the performance of circuit-interrupting equipment and protective devices. An appreciable number of these transient voltages are of sufficient magnitude to cause insulation breakdown.

The various factors that determine the magnitudes of currents and voltages in power systems during abnormal conditions will be discussed in this chapter.

I. STEADY-STATE VOLTAGES AND CURRENTS DURING FAULT CONDITIONS

1. Assumptions

Voltages and currents produced under fault conditions are a function of the type of fault and the ratios of the sequence impedances. The effect of these factors on the voltages and currents produced can be shown by sets of curves as will be done here. The four types of faults illustrated in Fig. 1 will be considered. It is assumed that the network is symmetrical to the point of fault, *F*, and can be reduced to series impedances, Z_1 , Z_2 , and Z_0 for

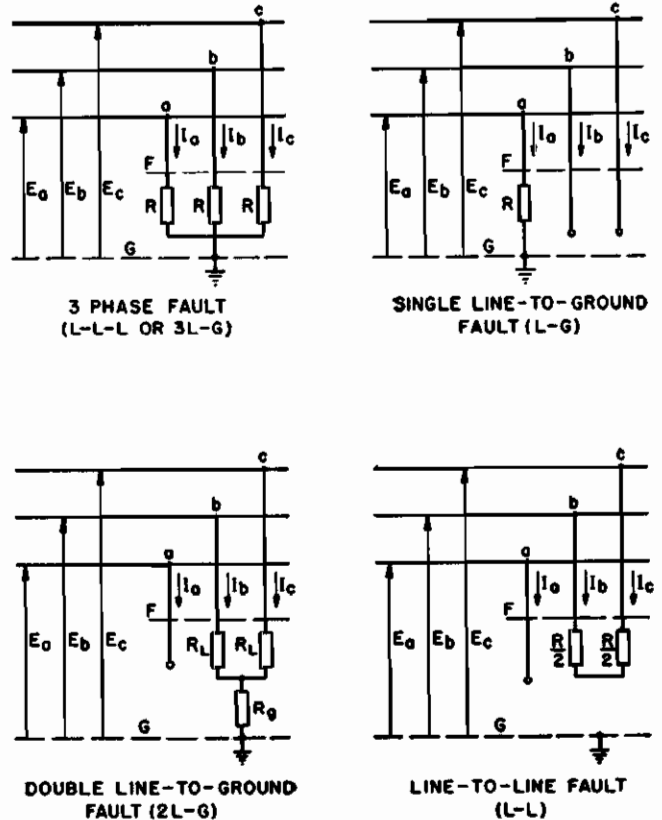

Fig. 1—Types of faults on three-phase systems.

the positive-, negative-, and zero-sequence networks, respectively. In the present analysis the fault resistance is represented by *R* and is not included in Z_0 . Z_0 includes all zero-sequence resistance to the point of fault but does not include the fault resistance. It is further assumed that all the generated emfs can be reduced to a single positive-sequence emf, E_g .

2. Formulas

In Tables 1 and 2 are given the formulas* for calculating the line currents and line-to-ground voltages for the faults illustrated in Fig. 1. These formulas are complicated to such an extent that it is difficult to visualize readily the currents and voltages that can be produced under fault conditions for ranges of system constants. For this reason the currents and voltages have been calculated for various

*Formulas taken from pages 224 and 226 of reference 1.

ratios of system constants and the results are presented as a series of curves.

3. Range of Sequence Impedances Considered

The principal impedances that usually apply to transient conditions are the positive-sequence impedance Z_1 , the negative-sequence impedance Z_2 , and the zero-sequence impedance Z_0 , each consisting of a resistance and a reactance component. In general, the positive-sequence resistance R_1 and the negative-sequence resistance R_2 are small in comparison to the positive- and negative-sequence reactances. Consequently, the effect of these two resistances on the magnitude of the voltages and currents during fault conditions is small. For this reason and because of complications introduced by considering positive- and negative-sequence resistances, these factors will be neglected. Zero-sequence resistance R_0 and zero-sequence reactance X_0 can vary through wide ranges depending on the type of system grounding used, hence the curves are arranged to cover a wide range of zero-sequence resistance and zero-sequence reactance.

The positive-sequence reactance that applies to transient conditions may be either the sub-transient or the transient reactance depending on whether or not the initial high decrement component of the current is to be considered or neglected. The ratio of X_2 to X_1 for commercial machines usually lies between 0.5 and 1.5, although with special machines it is possible to exceed this range. The higher ratios of X_2 to X_1 are in machines without dampers whereas the lower ratios are in machines with dampers or their equivalent. In general calculations it is usually permissible to assume a ratio of X_2/X_1 of unity especially if an appreciable percentage of the negative-sequence reactance to the point of fault is in static apparatus or transmission lines. The general curves are limited to ratios of X_2 to X_1 within the range of 0.5 to 1.5; the formulas in Tables 1 and 2 can be used for ratios outside of this range.

4. Fault Current and Voltage Curves

Curves prepared in accordance with the preceding discussion are plotted in Figs. 2 to 6 inclusive. In these figures the fault current is plotted as a ratio of the three-phase short-circuit, and the line-to-ground and line-to-line voltages are plotted as a ratio to their respective normal values.

In Figs. 2, 3, and 4 all resistances are equal to zero. Figs. 2 and 3 show the ranges of line currents and line-to-

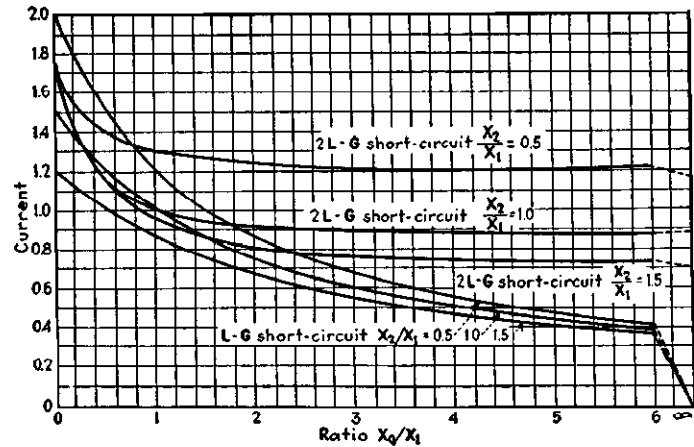

Fig. 2.—Curves of fault currents vs. system reactances for single and double line-to-ground faults. Each curve is labeled to indicate the type of fault and the ratio of X_2/X_1 . All currents are expressed as a ratio to the three-phase short-circuit current. For these curves, all resistances are assumed equal to zero.

ground voltages respectively for single and double line-to-ground faults for ratios of X_0/X_1 from zero to six. The ranges of fault current and fault voltages for ratios of X_2/X_1 between 0.5 and 1.5 are shown in Fig. 4.

The ranges of fault current for ratios of R_0/X_1 between zero and six are given in Fig. 5. In this figure the ratio X_2/X_1

TABLE 1—FAULT CURRENTS

Type of fault	Vector expression, effect of fault resistance included	Magnitude of currents when $R_0 = R_1 = R_2 = R = R_g = 0$
Three-phase.....	$I_a = \frac{E_g}{Z_1 + R}$	$I_a = I_b = I_c = \frac{E_g}{X_1}$
Line-to-line.....	$I_b = \frac{-j\sqrt{3}E_g}{Z_1 + Z_2 + R}$ $I_c = -I_b$	$I_b = I_c = \frac{\sqrt{3}E_g}{X_1 + X_2}$
Single line-to-ground.....	$I_a = \frac{3E_g}{Z_0 + Z_1 + Z_2 + 3R}$	$I_a = \frac{3E_g}{X_0 + X_1 + X_2}$
Double line-to-ground.....	$I_b = \frac{-\sqrt{3}E_g}{2\Delta v} \left[\sqrt{3}(Z_2 + R_L) + j(2Z_0 + Z_2 + 3R_L + 6R_g) \right]$ $I_c = \frac{-\sqrt{3}E_g}{2\Delta v} \left[\sqrt{3}(Z_2 + R_L) - j(2Z_0 + Z_2 + 3R_L + 6R_g) \right]$ $I_g = I_b + I_c = 3I_0$ $= \frac{-3E_g}{\Delta v} (Z_2 + R_L)$ $\Delta v = (Z_1 + R_L)(Z_2 + R_L) + (Z_1 + Z_2 + 2R_L)(Z_0 + R_L + 3R_g)$	$I_b = I_c = \frac{\sqrt{3}E_g}{\Delta_M} \sqrt{X_0^2 + X_0X_2 + X_2^2}$ $I_g = \frac{3E_g}{\Delta_M} X_2$ $\Delta_M = X_1X_2 + X_0(X_1 + X_2)$

Z_1 = positive-sequence impedance to the point of fault
 Z_2 = negative-sequence impedance to the point of fault
 Z_0 = zero-sequence impedance to the point of fault and does not include any fault resistance
 See Fig. 1 for definitions of R, R_L and R_g

covers the range of 0.5 to 1.5 and the ratio X_0/X_1 covers the range of zero to five. As pointed out previously, fault

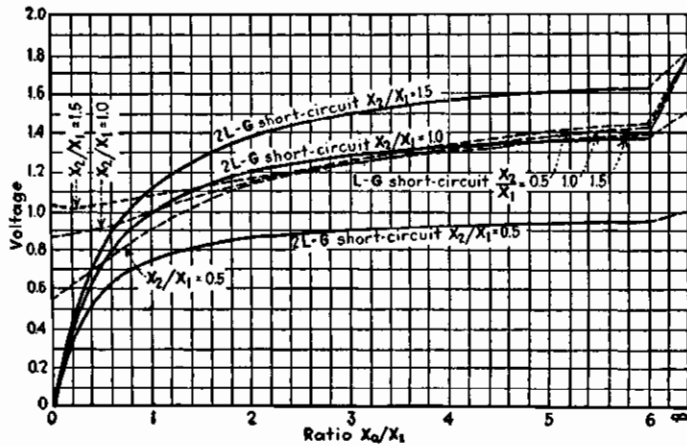

Fig. 3—Curves of fault voltages vs. system reactances for single and double line-to-ground faults. Each curve is labeled to indicate the type of fault and the ratio of X_2/X_1 . The voltages are from line-to-ground and are expressed as a ratio to the normal line-to-neutral voltages. For these curves, all resistances are assumed equal to zero.

resistance has been neglected in these curves; R_0 is the zero-sequence resistance to the point of fault F and does not include R , R_L , or R_g (see Fig. 1). It is, however, possible to include the effect of R and R_g in Fig. 1 by including them in R_0 .

The ranges of fault voltages for ratios of R_0/X_1 between zero and six are shown in Fig. 6. The ratios X_0/X_1 and

X_2/X_1 cover the same ranges as in Fig. 5. In the preparation of these curves fault resistance has been neglected. All voltages are measured to true ground at the point of fault.

In special cases, for example in the application of lightning arresters, it is necessary to consider the effect of fault resistance on the voltages produced during single line-to-

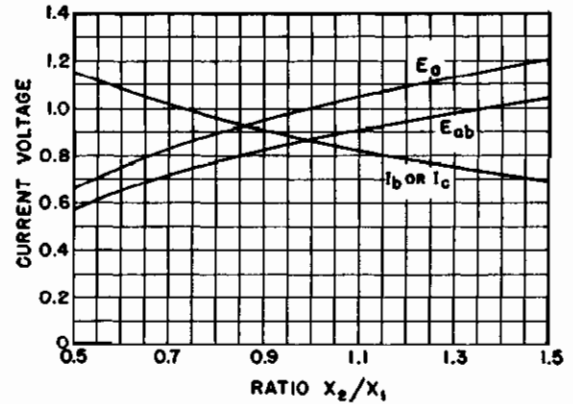

Fig. 4—Curves of fault voltages and currents vs. system reactances for line-to-line faults. Line-to-ground and line-to-line voltages are expressed as ratios to their respective normal values. Current is expressed as a ratio to the three-phase short-circuit current. All resistances are assumed equal to zero.

ground faults. The curves in Figs. 7 and 8 include this factor. The curves in Fig. 7 give the highest voltages from line to true ground for a fault through a fault resistance R_f .

TABLE 2—FAULT VOLTAGES

Type of Fault	Vector Expression, Effect of Fault Resistance Included	Magnitude of Voltages When $R_0=R_1=R_2=0$
Three-phase.....	$E_a = E_g \frac{R}{Z+R}$	$E_a = 0$
Line-to-line.....	$E_a = E_g \frac{2Z_2+R}{Z_1+Z_2+R}$ $E_b = -E_g \frac{\frac{R}{2} + j\frac{\sqrt{3}R}{2} + Z_2}{Z_1+Z_2+R}$ $E_c = -E_g \frac{\frac{R}{2} - j\frac{\sqrt{3}R}{2} + Z_2}{Z_1+Z_2+R}$	$E_a = E_g \frac{2X_2}{X_1+X_2}$ $E_b = E_c = E_g \frac{X_2}{X_1+X_2}$ $E_{ab} = E_{ac} = E_g \frac{3X_2}{X_1+X_2}$
Single line-to-ground.....	$E_a = E_g \frac{3R}{Z_0+Z_1+Z_2+3R}$ $E_b = -\frac{\sqrt{3}E_g}{2} \left[\frac{\sqrt{3}(Z_0+R) + j(Z_0+2Z_2+3R)}{Z_0+Z_1+Z_2+3R} \right]$ $E_c = -\frac{\sqrt{3}E_g}{2} \left[\frac{\sqrt{3}(Z_0+R) - j(Z_0+2Z_2+3R)}{Z_0+Z_1+Z_2+3R} \right]$	$E_a = 0$ $E_b = E_c = \sqrt{3}E_g \frac{\sqrt{X_0^2 + X_0X_2 + X_2^2}}{X_0+X_1+X_2}$ $E_{bc} = \sqrt{3}E_g \frac{X_0+2X_2}{X_0+X_1+X_2}$
Double line-to-ground.....	$E_a = \frac{3E_g(Z_2+R_L)(Z_0+R_L+2R_g)}{\Delta v}$ $E_b = -\frac{\sqrt{3}E_g}{2\Delta v} \left[\sqrt{3}(Z_2+R_L)(R_L+2R_g) + jR_L(2Z_0+Z_2+3R_L+6R_g) \right]$ $E_c = -\frac{\sqrt{3}E_g}{2\Delta v} \left[\sqrt{3}(Z_2+R_L)(R_L+2R_g) - jR_L(2Z_0+Z_2+3R_L+6R_g) \right]$ $\Delta v = (Z_1+R_L)(Z_2+R_L) + (Z_1+Z_2+2R_L)(Z_0+R_L+3R_g)$	$E_a = \frac{3E_g X_0 X_2}{\Delta_M}$ $E_b = E_c = 0$ $E_{ab} = E_{ac} = E_a$ $\Delta_M = X_1 X_2 + X_0(X_1+X_2)$

Z_1 = positive-sequence impedance to the point of fault
 Z_2 = negative-sequence impedance to the point of fault
 Z_0 = zero-sequence impedance to the point of fault and does not include any fault resistance
 See Fig. 1 for definitions of R , R_L and R_g .

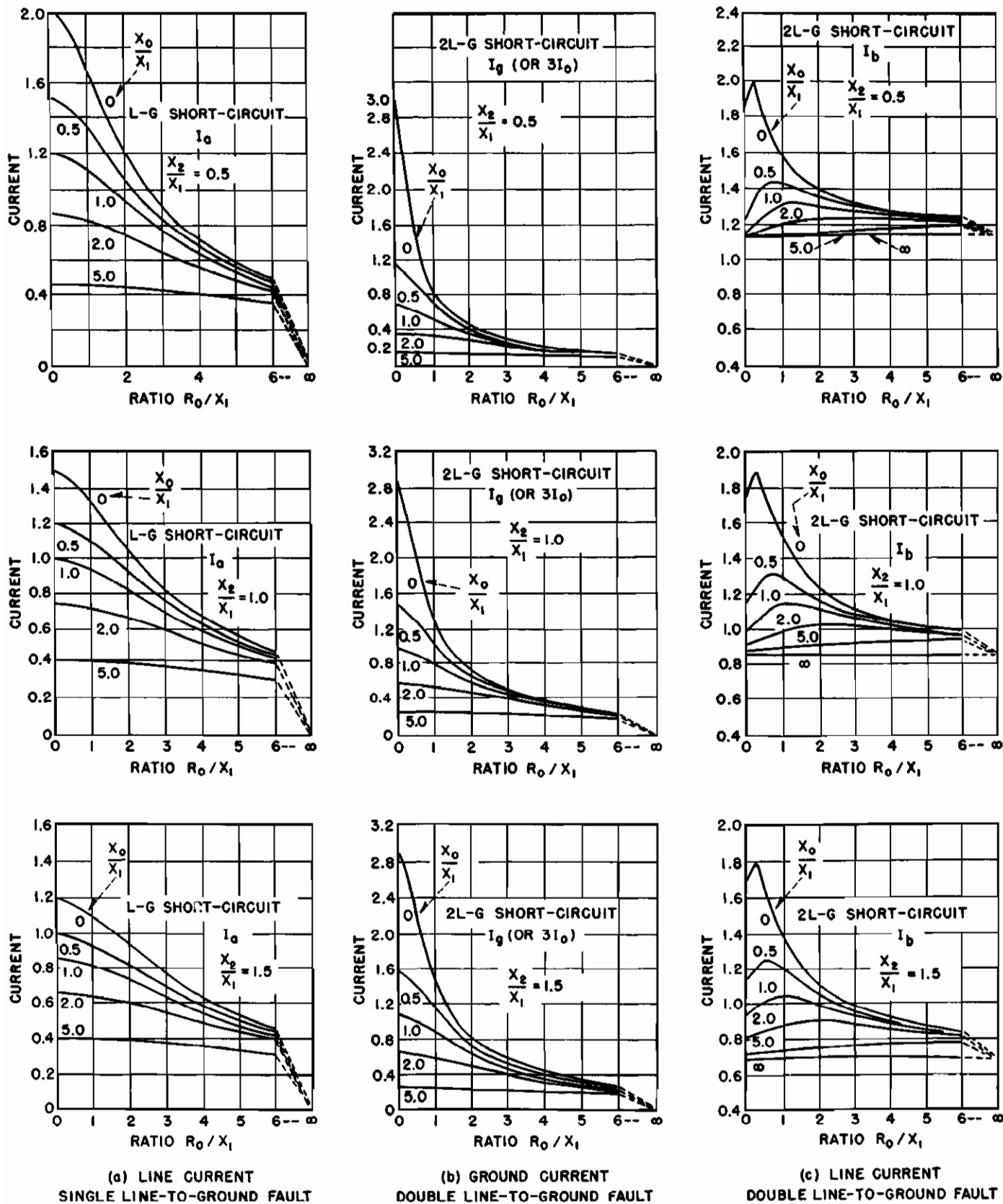
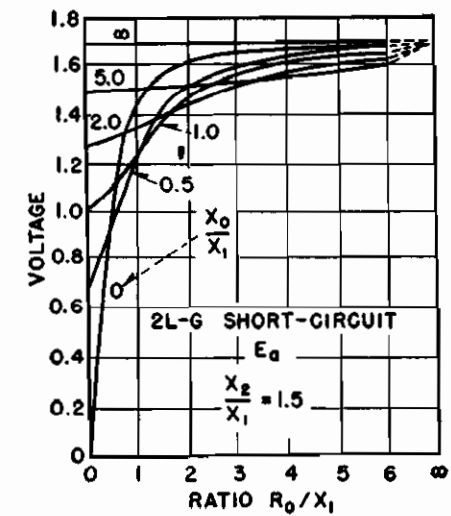
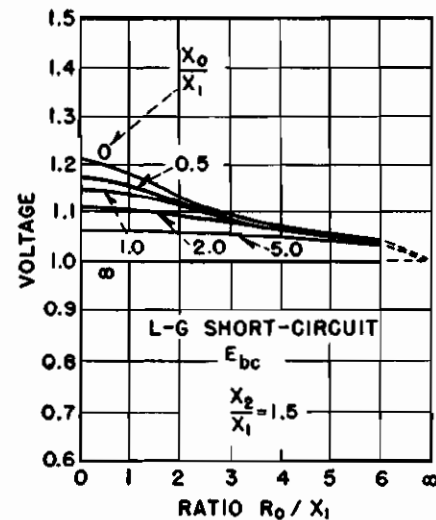
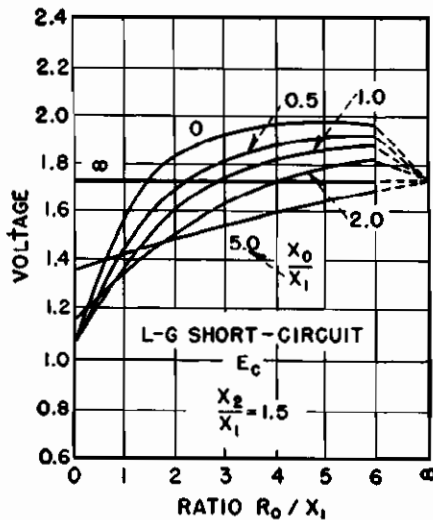
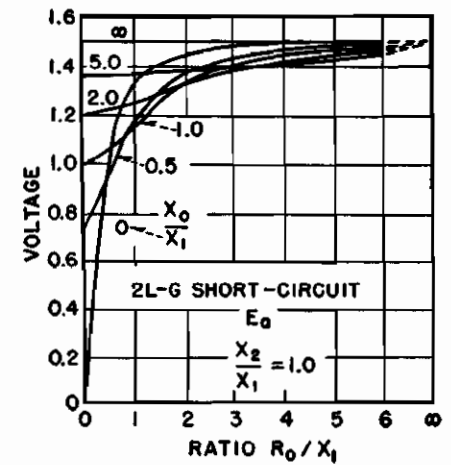
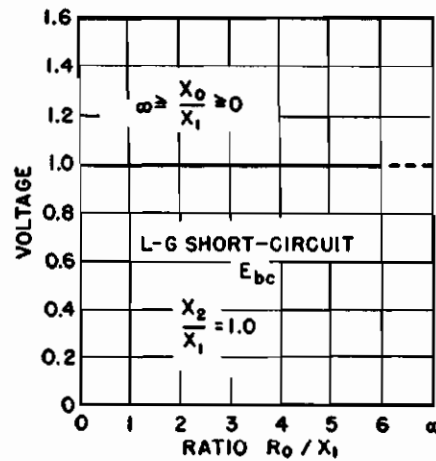
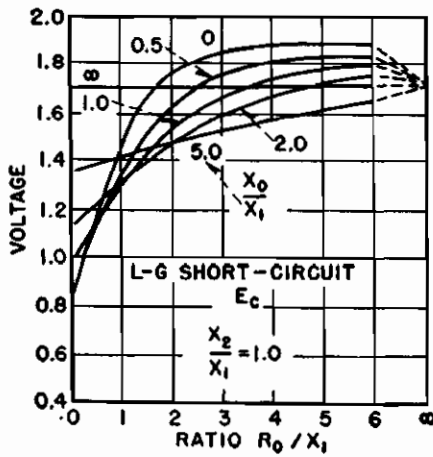
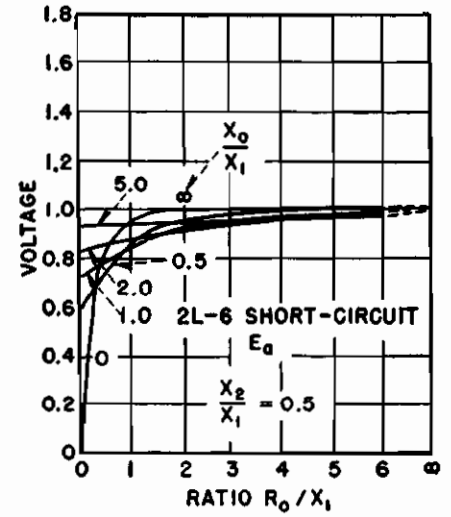
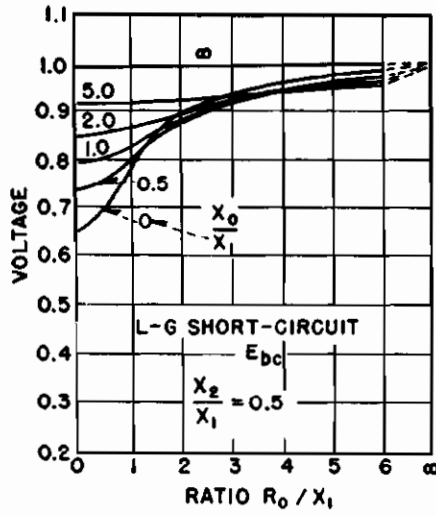
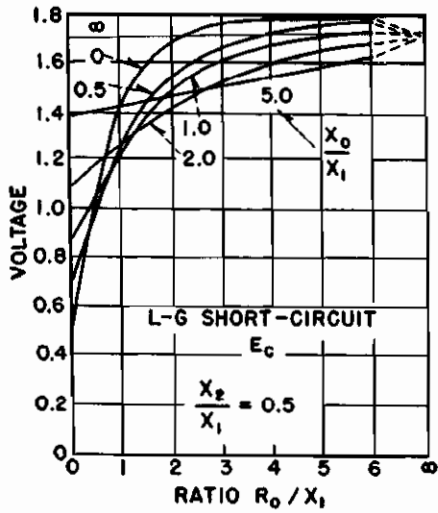

Fig. 5—Curves of fault currents vs. system impedances. The legend with each group of curves indicates the type of fault, the current plotted, and the ratio X_2/X_1 . The individual curves in each group are for various values of the ratio of X_0/X_1 . All currents are expressed as a ratio to the three-phase short-circuit current. R_0 is the zero-sequence resistance to the point of fault and does not include any fault resistance; the fault resistance is assumed equal to zero.



(a) LINE-TO-GROUND VOLTAGE
SINGLE LINE-TO-GROUND FAULT

(b) LINE-TO-LINE-VOLTAGE
SINGLE LINE-TO-GROUND FAULT

(c) LINE-TO-GROUND VOLTAGE
DOUBLE LINE-TO-GROUND FAULT

Fig. 6—Curves of fault voltages vs. system impedances. The legend with each group of curves indicates the type of fault, the voltage plotted, and the ratio of X_2/X_1 . The individual curves in each group are for the various values of the ratio of X_0/X_1 . Line-to-ground and line-to-line voltages are expressed as ratios to their respective normal values. R_0 is the zero-sequence resistance to the point of fault and does not include any fault resistance; the fault resistance is assumed equal to zero.

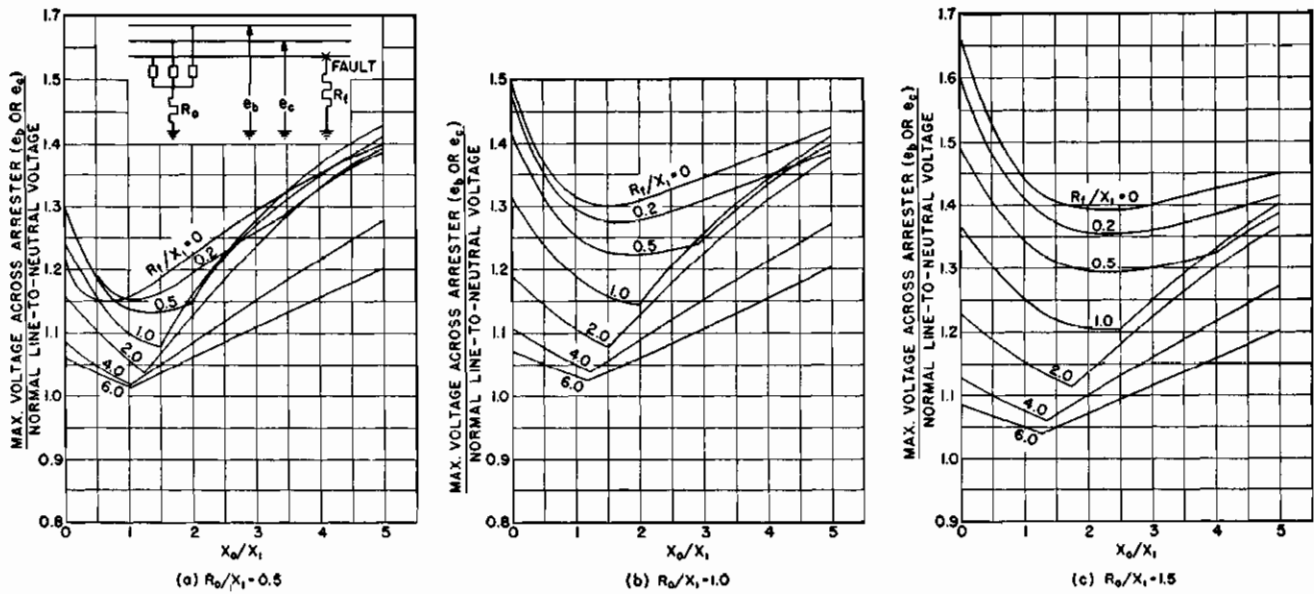

Fig. 7—Curves of line-to-ground voltages vs. system impedances for a single-line-to-ground fault through a fault resistance R_f . R_0 is the zero-sequence resistance to the point of fault and does not include R_a or R_f . X_2/X_1 is assumed equal to 1.0.

These curves cover a range of R_f/X_1 of zero to 6 and a range of R_0/X_1 of from 0.5 to 1.5. R_0 is the zero-sequence resistance to the point of fault and does not include R_f .

The curves in Fig. 8 show the voltages across an arrester for a fault to the arrester neutral. As in Fig. 7, R_0 is the zero-sequence resistance to the point of fault and does not include R_a .

Reference should also be made to Figs. 28 and 29 of Chap. 18, particularly in lightning arrester application

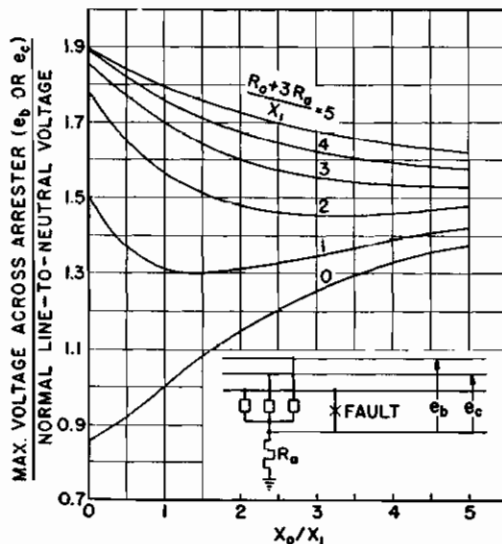

Fig. 8—Curves of the maximum voltages across a lightning arrester for a fault to the lightning arrester neutral point. R_0 is the zero-sequence resistance to the point of fault and does not include R_a , the resistance of the arrester ground. The fault resistance is assumed equal to zero and X_1/X_2 is assumed equal to 1.0.

problems. These figures give the maximum line-to-ground voltages during single- or double-line-to-ground faults on ungrounded and grounded-neutral systems.

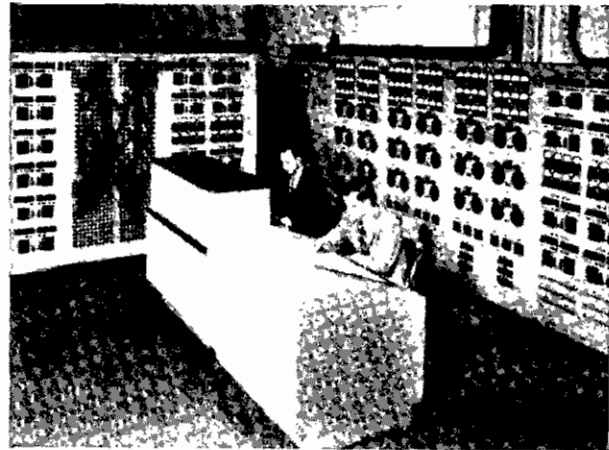

Fig. 9—A-c network calculator.

II. TRANSIENT VOLTAGES

A transient voltage of some magnitude is present on a power system each time a circuit change is made. This circuit change may be a normal switching operation such as the opening of a circuit breaker, or it may be a fault condition such as the grounding of a line conductor. The existence of transient voltages on power systems as a result of circuit changes caused by switching operations or faults was recognized at an early date². The phenomena, however, were not thoroughly investigated at the time because suitable measuring and recording devices were not available and because the immediate difficulties were largely overcome by the adoption of the practice of grounding power systems. The invention by J. F. Peters³ of the "klydonograph" made possible the collection of a mass of field data on transient voltages. However, the time and expense involved in making extensive field studies limited the scope of these investigations. Furthermore many investigators were concentrating their efforts on lightning, a

much more important problem at that time. The introduction of the protector tube for the protection of transmission lines, however, showed the need for a better understanding of power system transients because its performance is greatly affected by them. The first attempts to calculate transient voltages were made by conventional methods using differential equations. The limitations of conventional mathematical methods were soon apparent, however, because of the tremendous amount of time required. The introduction of the A-C Network Calculator Method of Studying Power System Transients⁴ gave a practical tool for studying the behavior of power systems under transient conditions and made possible general investigations of power-system transients. The later development of the Anacom, or analog computer,⁵ further increased the possible scope of power system investigations. It is the purpose of the following sections to describe these computing devices, and to present the results of general studies made with them.

5. The A-C Network Calculator Method of Studying Transient Voltages

To study transients on power systems by the A-C Network Calculator Method, the system in question is set up in miniature on the A-C Network Calculator. In Fig. 10 is shown the equivalent circuit for a relatively simple system consisting of a generator, a transformer, and a transmission line. The generator is represented by a low-impedance three-phase supply with additional impedance in series to give the miniature system the same impedance as the impedance of the actual system. The zero-sequence impedance of the source is represented by a grounding transformer of low impedance grounded through reactance or

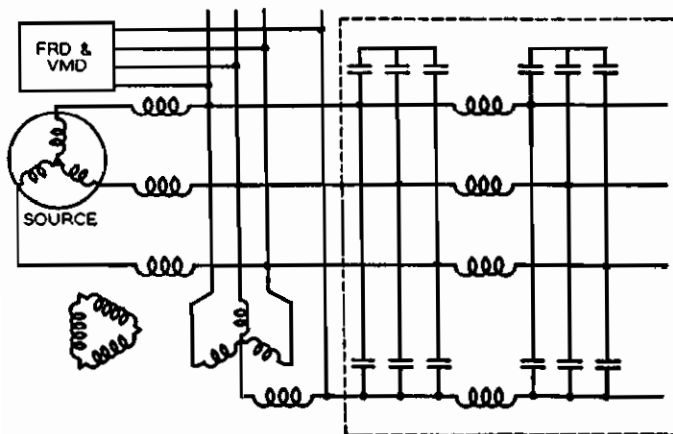

Fig. 10—Schematic diagram illustrating method of system representation used on the a-c network calculator.

FRD—Fault representation device
VMD—Voltage measuring device

resistance depending upon the type of grounding used. In the equivalent circuit in Fig. 10 the transmission line is represented by an equivalent π section. This type of line representation is used in some studies but often it is necessary to employ more complicated networks. The choice of the network to use for representing a section of line

depends upon several factors, such as line length, supply impedance, etc.

After the miniature system has been set up as shown in Fig. 10, the equipment shown diagrammatically in Fig. 11 is used for performing switching operations or for applying faults. Each of the synchronous switches shown at the

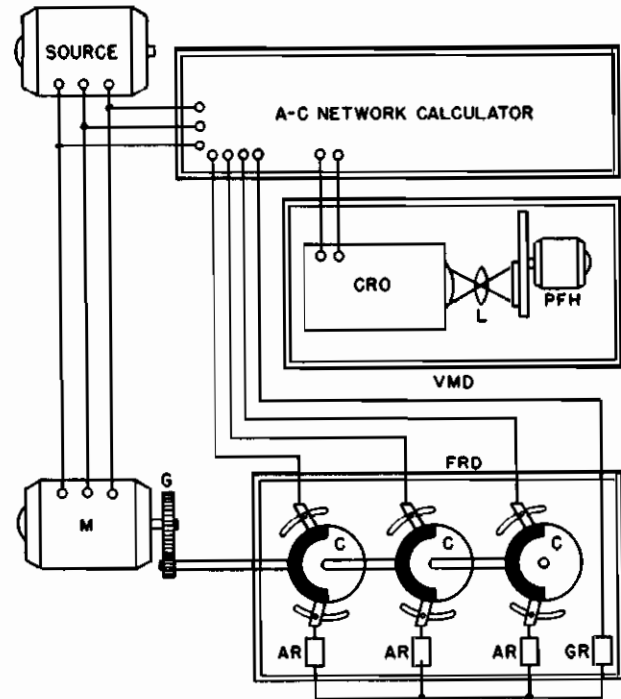

Fig. 11—Schematic diagram showing equipment used in a-c network calculator method of studying transients.

M—Synchronous motor
G—Gear
FRD—Fault representation device
C—Synchronous switches
AR—Arc resistance representation
GR—Ground resistance representation
VMD—Voltage measuring device
CRO—Cathode-ray oscilloscope
L—Lens system
PFH—Polar film holder

bottom of Fig. 11 consists essentially of a conducting and an insulating segment on a drum and two movable brushes, one for controlling the closing and the other the opening of the switch. Each brush is located on a gear that can be rotated by a worm, making the brush adjustable through 360 degrees.

For representing faults on power systems the switches are connected between line and ground or between lines depending upon the type of fault being studied. Where circuit breaker operations are to be simulated the switches are inserted in series with the line. The switching operations are repeated once per revolution of the drum and, as the drums are rotated by a synchronous motor, the switching operations always take place in synchronism with the system voltage. The transient voltage produced by the switching operation is therefore repeated once per revolution of the drum. All transient voltages are measured by a

cathode-ray oscilloscope connected to the miniature network. By repeating the transient a number of times per second, the equivalent of a steady-state voltage is produced on the screen of the cathode ray oscilloscope. This makes it possible to study a transient that lasts for a fraction of a cycle without taking oscillograms. The effect of initiating

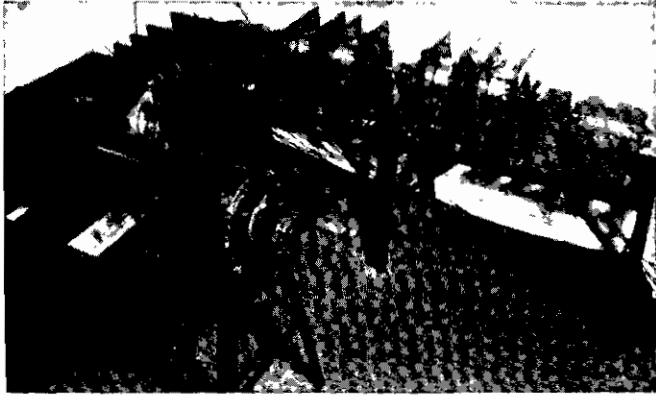

Fig. 12—Switching and recording equipment used with a-c network calculator.

the transient at different points on the normal dynamic voltage wave can be studied by simply changing the positions of the brushes on the synchronous switch. The time interval between successive transients is so chosen as to bring the system back to normal between switching operations.

6. The Analog Computer

The analog for many systems (electrical, mechanical, thermal, etc.) requires low-loss inductance coils, amplifiers, multipliers, and other special circuit elements. The analog computer,⁵ or Anacom, was developed primarily for the solution of these systems. Its characteristics, however, make it ideally suited to the solution of all power-system transient problems formerly studied on the a-c network calculator. The Westinghouse Electric Corporation now makes all electric transient studies on the Anacom, reserving the a-c network calculator for power system problems such as voltage regulation, load flow, stability, etc.

In most cases the procedure for setting up a problem and obtaining a solution is the same with the Anacom as with

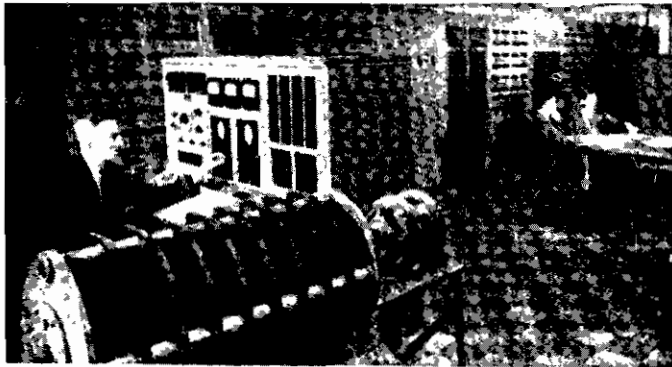

Fig. 13—General view of the large-scale, general-purpose electric analog computer.

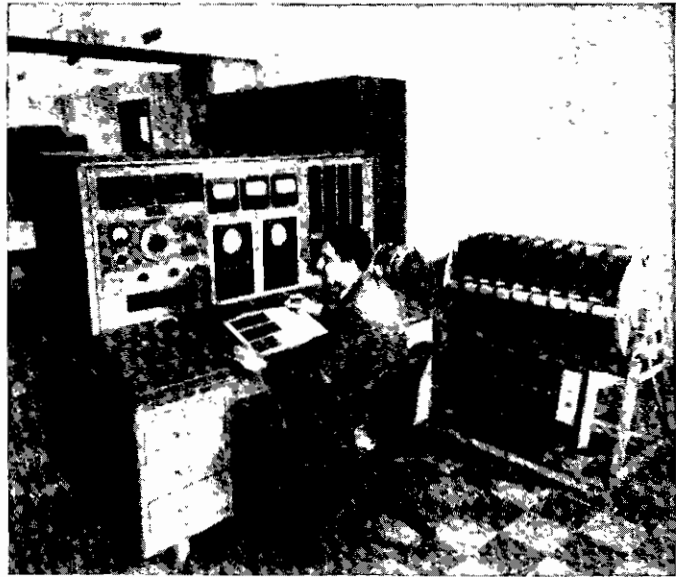

Fig. 14—Close-up view of the Anacom control desk and synchronous switch.

the a-c network calculator. An analog is formed by connecting circuit elements, R , L , and C , into a circuit that has the same differential equation as the system under consideration. Synchronous switches are usually used to repeat the desired transient solution a number of times per second, which permits visual and photographic measurements on a cathode-ray oscilloscope. In power system studies the switches normally represent circuit breaker operation or faults.



Fig. 15—Details of an Anacom inductance-resistance drawer.

The computer elements include inductance coils having a Q of 100 or higher over the frequency range from 100 to 1000 cycles; precision capacitors and resistors; special transformers having minimum exciting current, leakage impedance, and distributed capacitance; amplifiers, and multipliers. Special analogs have been developed to represent lightning arresters, corona, and other non-linear char-

acteristics. The use of the synchronous switches in combination with R , L , and C circuit elements, amplifiers and multipliers permit the formation of special forcing functions such as lightning surges, air-gap torques in turbine generators during short circuits, etc. The measuring equipment includes cathode ray oscilloscopes with suitable photographic means, harmonic analyzers, wire and tape recorders, and all types of conventional ammeters, voltmeters and wattmeters.

The Anacom is arranged with d-c, 440-cycle, and 60-cycle power supplies to solve problems normally assigned to the a-c and d-c network calculators; however it is normally used in the transient field. It is suited to the solution of many problems of concern to power company engineers, including recovery voltage, switching-surge and arcing-ground investigations, surge-protection applications, turbine generator short-circuit torques, analysis of generator voltage regulating systems and motor-starting problems. It can be used in solving many equipment design problems such as surge-voltage distribution in transformers and rotating machines, dielectric field mapping, and heat-flow. Its possible application in the fields of applied mechanics, hydraulics, thermodynamics and servomechanisms is almost unlimited.

7. Recovery Voltage

Theory—One transient phenomenon studied by the A-C Network Calculator Method is system recovery voltage, which is important because of its effect upon the operation of circuit interrupting and protective devices, such as circuit-breakers, protector tubes, etc. The simple circuit in Fig. 16 can be used for defining system recovery voltage

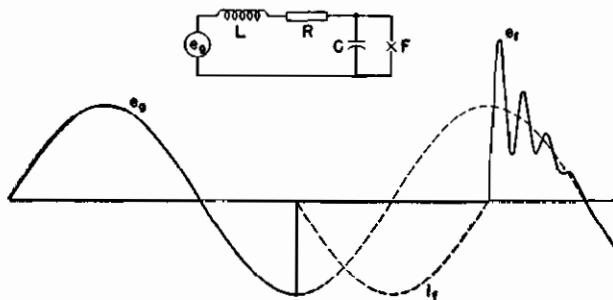

Fig. 16—Simple system for illustrating recovery voltage for a fault (F).

e_f —Voltage across fault
 i_f —Fault current

ages. In this circuit a condenser C is used to represent a transmission line, and a voltage and an impedance, the source. Applying a short-circuit across the condenser in this circuit is equivalent to applying a line-to-ground fault on a single-phase power system. During the time the condenser is short-circuited, a fault current i_f will flow. If the resistance in the source is small in comparison to the reactance, this fault current will lag the generated voltage e_g by approximately 90 degrees. If the short-circuit is removed at the instant the fault current passes through zero, the voltage across the condenser will not immediately return to normal but will reach normal only after a series of oscilla-

tions. No voltage can appear across the condenser until it is charged up and the charging rate is fixed by the source inductance and the capacitance. When the short-circuit is removed, the condenser voltage will be accelerated toward normal but will overshoot because of the circuit inductance. If no losses were present in the circuit the transient voltage across the condenser would reach a crest equal to twice normal crest voltage. In a practical circuit with some loss, the oscillation will not quite reach twice normal; it will eventually be damped out, leaving only the normal-frequency voltage across the condenser.

This transient voltage across the condenser, following the removal of the fault, is commonly referred to as the system recovery voltage as it defines the manner in which the system voltage "recovers" following the removal of the fault. Changing the source reactance in the circuit in Fig. 16 is equivalent to changing the amount of generation connected in a power system, and changing the value of capacitance is equivalent to varying the length of line connected. The natural frequency of the oscillation in the circuit in Fig. 16 depends upon both the inductance and the capacitance and varies inversely as the square root of the product of these two quantities. The recovery voltage of a power system therefore depends upon the connected generator capacity and the length of line.

The De-ion Protector Tube—As previously stated, recovery voltage is important because of its effect on the performance of circuit interrupting and protective devices. This can be shown by a detailed study of the operation of a De-ion protector tube. A typical installation of protector tubes is shown in Fig. 17. In this case the protector tube is mounted vertically just below the line conductors. The lower electrode of the tube is connected to ground and the upper electrode is connected to an arcing horn used to maintain a constant external gap between the upper elec-

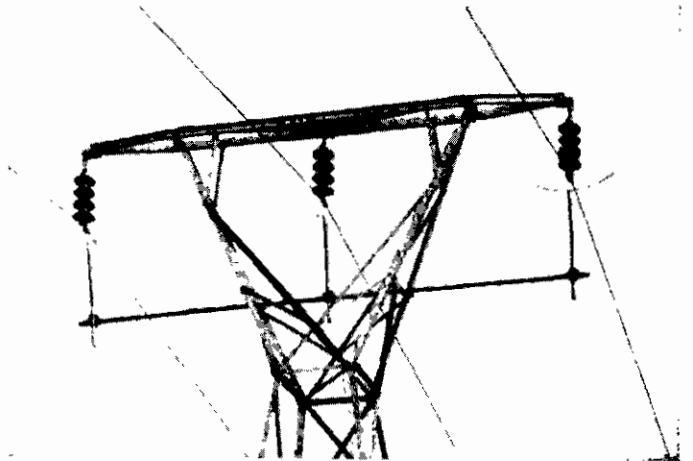

Fig. 17—Typical installation of De-ion protector tubes.

trode and the line conductor. The cross-section of a protector tube in Fig. 18 shows the two electrodes and the internal gap. In operation, lightning striking the line breaks down the series gap instead of flashing over the insulator string because the tube has the lower breakdown voltage. After breakdown of the gap, power-follow current volatilizes a small layer of the fiber wall and the gas given

off mixes in the arc to help de-ionize the space between the electrodes. A pressure is built up in the tube and the hot gases are discharged through the lower electrode, which is hollow. If the de-ionizing action is sufficiently strong and if the voltage does not build up too rapidly across the tube, the arc will go out at a current zero and will not be re-established.

While the tube is discharging, it is a good conductor and after the arc has been extinguished it is a good insulator.

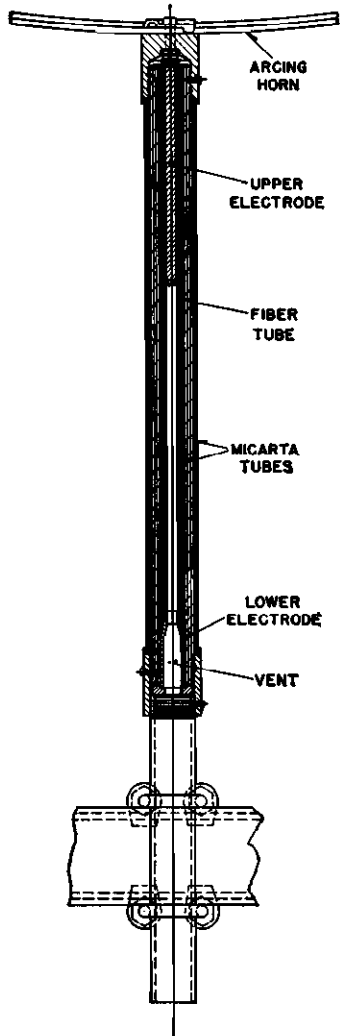

Fig. 18—Cross-section of a typical De-ion protector tube.

This change from a good conductor to a good insulator does not take place instantaneously because time is required to discharge the hot gases from the tube. It is therefore important that the voltage across the tube does not build up more rapidly than the change in the protector tube dielectric strength. This is where recovery voltage enters the picture because recovery voltage determines the rate of build-up of the voltage across the tube.

In Fig. 19 the recovery voltage for the circuit in Fig. 16 is replotted to a larger scale. Curves A and B in this figure are typical of the shape of insulation recovery curves for two different protector tubes. It is of utmost importance that the protector tube insulation recovery curves always

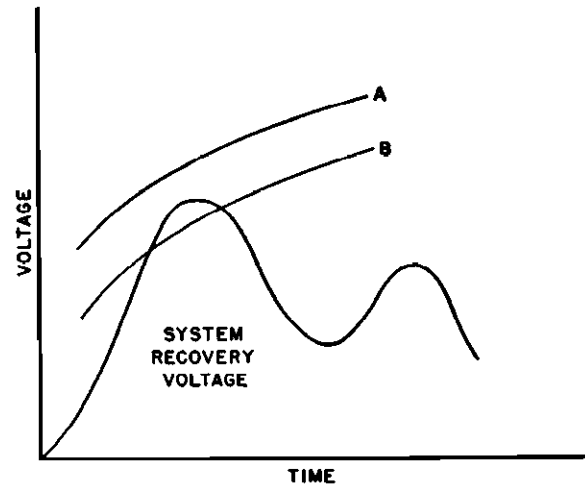

Fig. 19—Comparison of system recovery voltage and insulation recovery curves.

A—Insulation Recovery Curve for Tube A
B—Insulation Recovery Curve for Tube B

lie above the system recovery voltage curve, otherwise the arc will be re-established in the tube. Protector tube B would not operate satisfactorily on a system having recovery voltage characteristics similar to the recovery voltage in Fig. 19. A tube similar to tube A would have to be used.

The recovery voltage for the simple circuit in Fig. 16 is made up of a single-frequency oscillation. In a practical power system, the recovery voltage does not usually consist of a single-frequency oscillation but is usually made up of two or more high-frequency components. In Fig. 20 is shown the recovery voltage following a single line-to-ground fault on a 138-kv, three-phase system having a symmetrical three-phase short-circuit current of 1000 amperes and 90 miles of overhead transmission line. The recovery voltage in this case consists of two high-frequency components and is typical of the shape of the recovery voltage on many three-phase power systems.

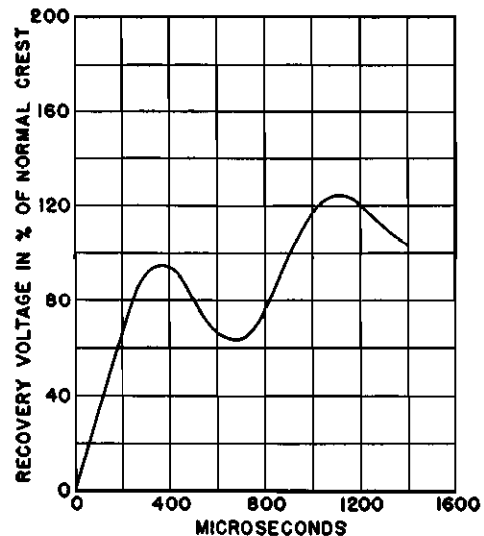

Fig. 20—Recovery voltage curve for a typical power system.

General Recovery Voltage Study—A broad perspective of the recovery-voltage problem can be obtained from the study of a representative set of systems. For this purpose three-phase, 60-cycle systems with transmission lines of three voltage classes, namely, 34.5, 69, and 138-kv were selected. Since the recovery voltage of a system is materially affected by the length of connected line, the lengths were selected to represent the shortest that would be encountered at that particular voltage for the large majority of systems. These selections were as follows: 22.5 miles for 34.5 kv, 45 miles for 69 kv, and 90 miles for 138 kv. Although it was recognized that more than one circuit would be required to transmit the maximum amount of power a single-circuit line was used because this gives the more severe recovery-voltage conditions.

The general features of these systems are shown schematically in Fig. 21. For each voltage class three different

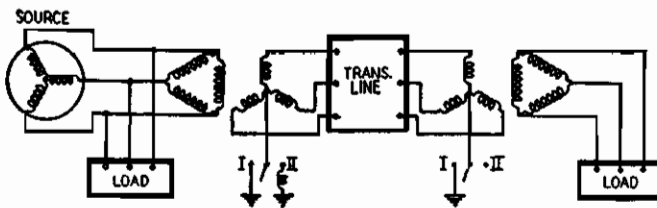

Fig. 21—Schematic diagram of system selected for study.

- Group I. Solidly grounded at both ends. Used for curves of Fig. 22.
- Group II. Reactance grounded at sending end; ungrounded at receiving end. Used for curves of Fig. 23.

conditions were assumed, each having different amounts of generating capacity and load. Table 3 gives the symmetrical three-phase short-circuit current that would be encountered for a "bolted fault" at the sending end. Systems capable of supplying the higher short-circuit currents have in general larger connected loads. Table 3 gives the ratio of short circuit kilovolt-amperes to load kilovolt-amperes

TABLE 3—CHARACTERISTICS OF SYSTEMS SELECTED FOR STUDY

Voltage	34.5 Kv	69 Kv	138 Kv
Short-Circuit Amperes			
(a)	500	500	500
(b)	2 000	2 000	1 000
(c)	6 000	6 000	4 000
Short-Circuit KVA			
Load KVA	5.0	4.0	3.0
Line Length (miles)	22.5	45	90

that was used in this study. Both no-load and loaded conditions were considered. An 80 percent power factor load was divided equally between the generator bus and the receiver bus as shown in Fig. 21.

The generating and transformer capacities were proportioned to the load for the particular system and short-circuit current, and typical constants were assumed for all of the system elements. Transmission lines without ground wires were chosen. The additional complication to take care of the cases with ground wires is not warranted be-

cause the problems are similar and also the recovery voltages are less severe when ground wires are used.

In making the general analysis the factors varied were: method of grounding, load, type of fault, fault resistance, arc resistance, and location of fault. The studies can conveniently be divided into two groups with respect to the method of grounding, namely: group I with system solidly grounded both at sending- and receiving-end transformers, and group II with the system grounded through a reactance at the sending end only. The solidly grounded systems, of group I, were studied for both single line-to-ground and double line-to-ground faults and for fault or tower-footing resistance of 0, 25, and 100 ohms, and with and without resistance for arc representation. The effect of load was investigated by comparing the results of the above tests with results of a few tests made without load and without fault or arc resistance. The second set of tests for the reactance-grounded system, group II, was made with the addition of a neutral reactor of such magnitude as to make the zero-sequence reactance at the sending end equal to 8.5 or 34 times the zero-sequence reactance of the supply transformer.

Results of General Study—In an investigation of this type it is not practical to consider the application of the fault at several points of the system. A preliminary study was, therefore, made to determine the effect of moving the fault along the line. Considering the shape of insulation-recovery voltage curves for specific pieces of apparatus, it was concluded that the recovery-voltage conditions were about as severe for faults at the sending end as at any location along the line. Therefore, the fault at the sending end was considered to be representative and was used in the general studies.

Based on the selected systems, a series of studies was made on the a-c network calculator to determine the effect of the different factors entering into the recovery-voltage problem. These studies may be divided into two groups; group I for systems with solidly-grounded neutral, and group II for the reactance-grounded systems, described in connection with Fig. 21. The results of these studies are presented in Figs. 22 and 23 respectively. The manner in which these data are plotted can more readily be understood by referring to Fig. 20. The recovery voltage curve in this illustration has two predominate crests. If the insulation recovery curve for a protector tube lies above these crests, the tube will perform satisfactorily. In the general application of protector tubes it is not necessary to have the complete recovery-voltage curve if the data corresponding to these predominate crests are available. Therefore, in summarizing the results of the general study only the data pertaining to these predominate crests were plotted in Figs. 22 and 23.

Referring to Fig. 22, it will be seen that for each voltage class studied the time to the first crest and to the maximum overshoot, as well as the magnitude of the first crest and the maximum overshoot are presented for the single line-to-ground and double line-to-ground fault cases. For these curves the abscissa is the current magnitude for a symmetrical three-phase short-circuit at the sending end. The results for a system under load are plotted for each current condition, with and without the arc representation device

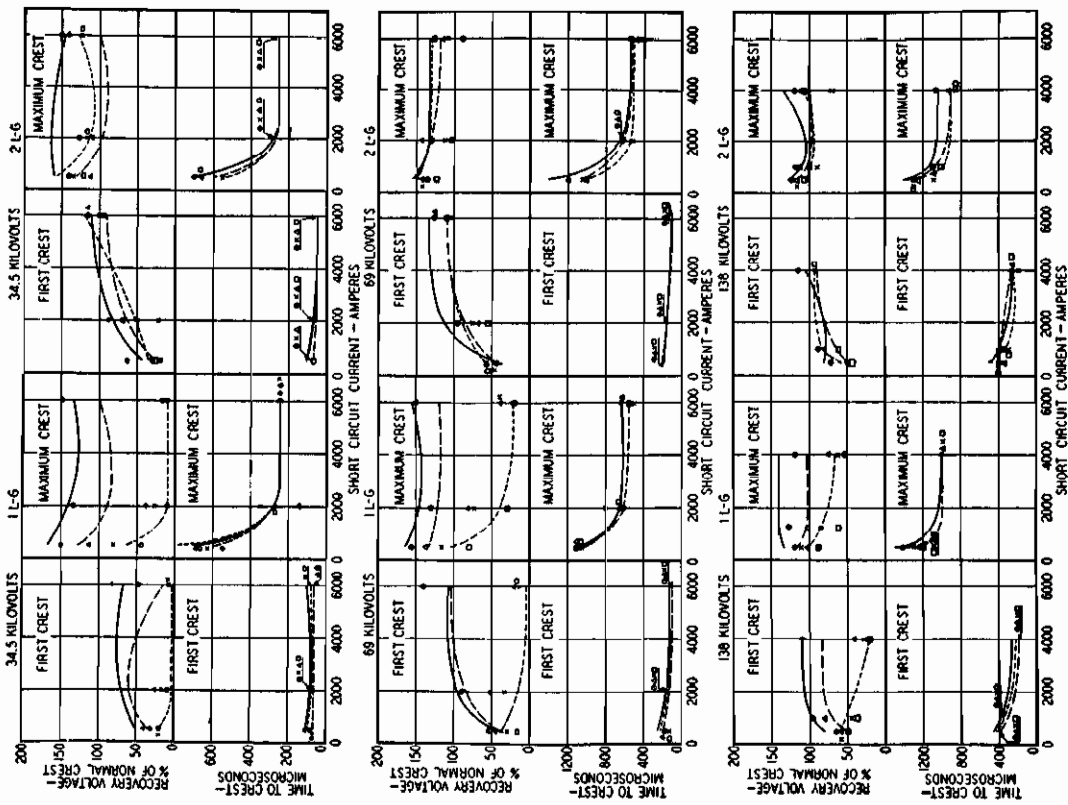

Fig. 22—Recovery voltage curves and plotted points for nine selected systems.

Group I. Solid grounding. Voltage magnitude and time to crest plotted as a function of three-phase symmetrical short-circuit current at the sending end.
 1-L-G—single line-to-ground fault.
 2-L-G—double line-to-ground fault.

Load	Arc Resistance	Tower-Footing or Ground Resistance (Ohms)
— No	No	0
— Yes	Yes	0
— Yes	No	100
○ Yes	No	0
△ Yes	No	25
× Yes	Yes	25
□ Yes	Yes	100

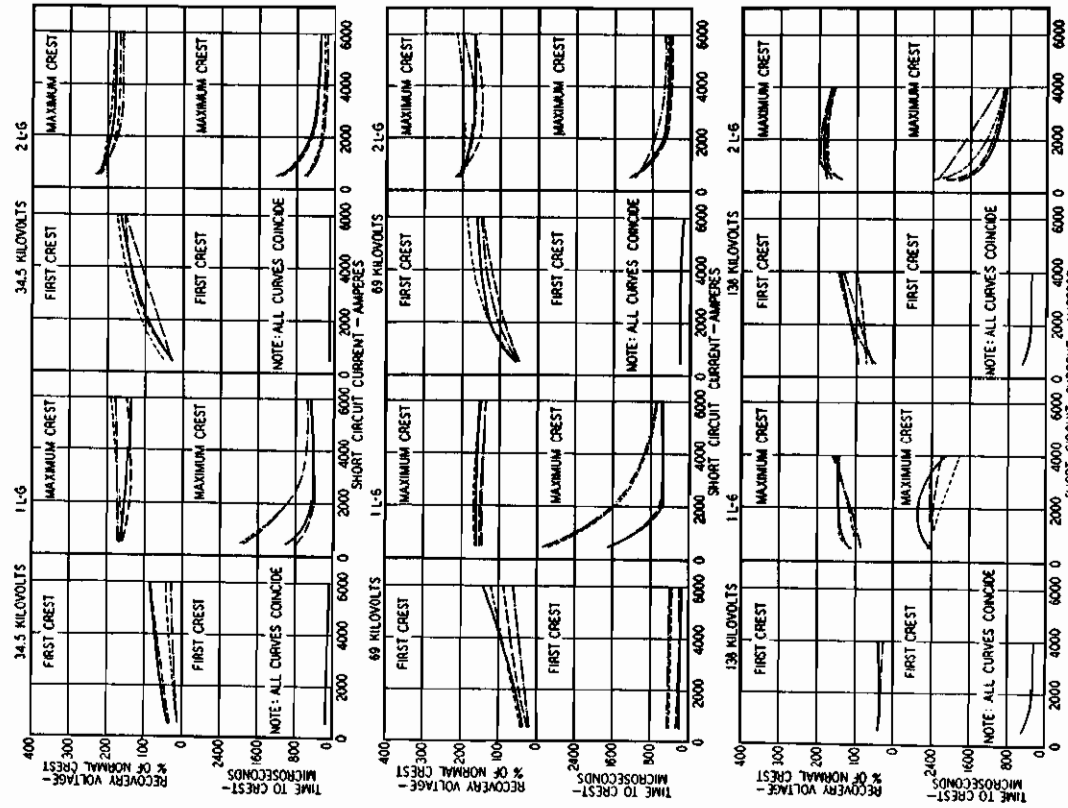

Fig. 23—Recovery-voltage curves.

Group II. Reactance grounding. Voltage magnitude and time to crest plotted as a function of the three-phase symmetrical short-circuit current at the sending end.
 1-L-G—single line-to-ground fault.
 2-L-G—double line-to-ground fault.

Reactance Value	Arc Resistance
— Low	No
— Low	Yes
— High	No
— High	Yes

for 0-, 25-, and 100-ohms tower-footing resistance. For comparison, one study with no load and with zero arc and tower-footing resistance is plotted. The arc representation device makes use of Rectox resistors to simulate the arc characteristics of a protector tube. The Rectox resistor was adjusted to give approximately 20 percent of line-to-neutral voltage at the peak of the symmetrical short-circuit current wave.

Fig. 23 presents the results of similar studies made on the same systems except with reactance grounding. The system arrangement with respect to grounding is shown in Fig. 21.

Application of Data—Although the recovery-voltage data presented are useful in a number of applications, the particular application of the protector tube will be taken as an illustration. The case of a 34.5 kv solidly-grounded system with 22.5 miles of transmission line with a symmetrical three-phase short-circuit current of 4,000 amperes at the sending end has been selected. No-load and zero-arc and tower-footing resistance give the highest recovery voltage for both single-line-to-ground and double-line-to-ground faults as shown in Fig. 22. The data for these two cases have been plotted in Fig. 24. The insulation recovery curves for two protector tubes are also included in this figure. Curve T_1 extends below the system recovery voltage curve for the case of a single-line-to-ground fault but is always above the corresponding curve for the case of a double-line-to-ground fault. As both types of faults must be considered in the application of protector tubes, a tube

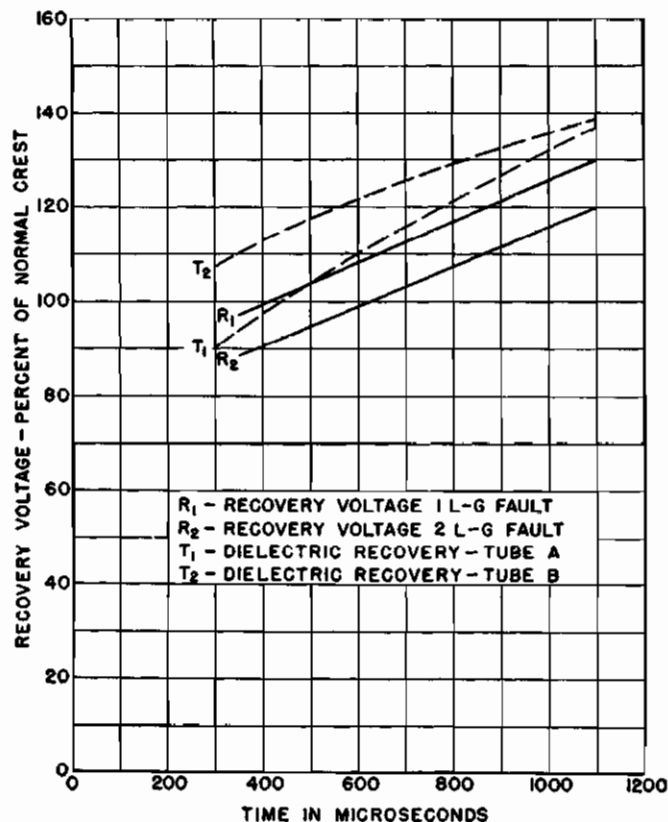

Fig. 24—Comparison of system recovery voltage and dielectric recovery curves for De-ion protector tubes. Recovery voltage data re-plotted from Fig. 22.

having characteristics similar to curve T_2 should be used for this system.

Using the data in Figs. 22 and 23 it is possible to predict the performance of any protector tube on any of the typical systems studied in this general investigation. A more detailed discussion of the application of these data is included in Chap. 17.

8. Distribution-System Recovery Voltage Characteristics

The data in Sec. 7 are not generally applicable to the lower-voltage circuits because of the differences in source reactances, circuit arrangements, line lengths, conductor spacings, etc. For this reason, a study⁷ was made on the analog computer to obtain fundamental data on the re-



Fig. 25—Distribution system selected for study on Anacom.

covery voltage characteristics of circuits in the 2400- to 13 800-volt range. The general study was limited to the case of a four-wire, multi-grounded system supplied from a delta-star power transformer, connected to an infinite bus on the primary side and solidly grounded on the secondary side.

Geometric-mean distances of 2.66 feet between phase conductors, and 4.1 feet between the phase and the neutral conductors were assumed. These spacings give reactances that are an average of the values obtained over the range of spacings normally used between 2400 and 13 800 volts. The small variations introduced by changes in spacing are not considered significant in the general problem. A conductor height of 30 feet and a ground resistivity of 100 meter ohms were used in all studies. The phase- and neutral-conductor sizes were assumed to be the same, and were varied between 4/0 and No. 6 copper. The line constants for these two extreme conductor sizes are included in Table 4.

TABLE 4—CONSTANTS OF TYPICAL DISTRIBUTION CIRCUITS

System	Copper Size	Z_1	Z_0	C_1	C_0
4-wire	4/0	$0.278 + j0.615$	$0.564 + j1.89$	0.0187	0.0078
	No. 6	$2.18 + j0.756$	$2.93 + j2.77$	0.0149	0.0069
3-wire	4/0	$0.278 + j0.615$	$0.564 + j3.15$	0.0187	0.0063
	No. 6	$2.18 + j0.756$	$2.47 + j3.29$	0.0149	0.0059
Single-phase	4/0	$Z = 0.373 + j1.04$			

Note: All impedances in ohms per mile at 60-cycles. All capacitances in microfarads per mile.

Fault location was found to have a significant effect so faults were applied on the sending-end bus and at the $\frac{1}{4}$, $\frac{1}{2}$, and 1.0 points, the latter being the open end of the line.

The studies were made by applying single- and double-line-to-ground faults at four locations, and recording the

times to 90-percent voltage, and the times and magnitudes associated with the maximum recovery-voltage transient. These data are illustrated in Fig. 26 for the case of a single-line-to-ground fault on an eight-mile system. Time is expressed in microseconds and voltage in percent of normal line-to-ground crest voltage. It is evident that fault location has considerable influence on the pertinent data. With

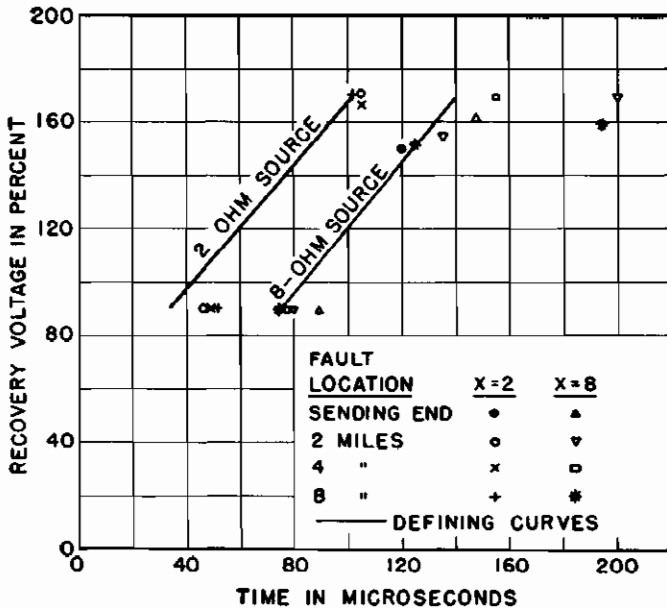

Fig. 26—Method of recording and interpreting data illustrated for one line-to-ground fault on eight-mile, four-wire system.

a two-ohm source, the time to 90-percent voltage is a minimum for a sending-end fault, whereas a receiving-end fault dictates this time with an eight-ohm source. Maximum voltages are obtained for faults away from the sending-end bus. However, many cases were noted where the maximum voltage did occur for sending-end faults, especially where small line conductors were represented. This illustrates the complexity of the problem, and the need for considerable data before formulating conclusions.

As it would be impractical to summarize, in the form of useful curves, all of the data obtained, a simple uniform method of interpretation was adopted. As a protective device must function at any location on a circuit, it is necessary to know only the most severe circuit conditions, regardless of fault location. With this in mind, a straight line was drawn to connect the points giving the minimum times to 90-percent and maximum recovery voltage. This line then defines the voltage-recovery characteristics of the particular system. In certain cases, such as the eight-ohm system in Fig. 26, the defining straight line was extended through one maximum voltage point to a horizontal line that intercepts the highest voltage recorded. This results in a simple method of plotting data without being ultra-conservative. In the case illustrated, the maximum recovery voltage would be recorded as 170 percent at 140 microseconds.

The times to 90 percent and to maximum recovery voltage were obtained by plots similar to Fig. 26. These times

were then reduced to a one-mile basis by dividing by the line length in miles; then plotted as a function of the X/M ratio (ratio of source ohms to line length in miles). These data are summarized in Fig. 27 for single- and double-line-to-ground faults, and 4/0 and No. 6 copper conductors. The times, for a given X/M ratio, do not vary greatly with the type of fault or the conductor size, even though consideration was given to various fault locations. For this reason, it was decided that practical answers could be obtained by drawing a single curve under each set of data. The differences between the actual times and those defined by the lower-limit curves were not considered important in view of the complexity of the overall problem, and the complicated circuits encountered in practice. The actual times for any given line length can be obtained by multiplying the values in Fig. 27 by the line length in miles.

The maximum voltages measured are plotted in Fig. 28 as a function of the X/M ratio. Values are included for four conductor sizes, which allows an evaluation of this

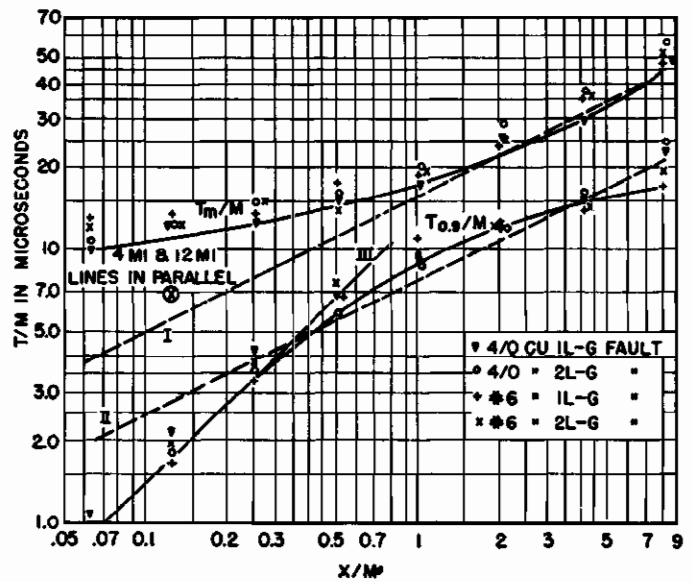
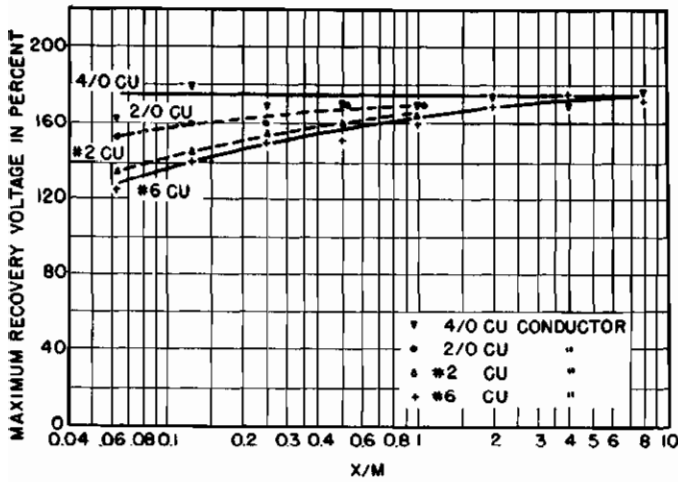

Fig. 27—Times to 90 percent and maximum recovery voltage referred to a one-mile line basis. $T_{0.9}/M$, T_m/M —times to 90 percent and maximum voltage divided by line length in miles.

- X—60-cycle source reactance in ohms
- I— T_m/M neglecting line inductance
- II— $T_{0.9}/M$ neglecting line inductance
- III— $T_{0.9}/M$ neglecting line reflections

variable on the voltages obtained. Conductor size has the most influence on the maximum voltages when the X/M ratio is small. With 4/0 conductors the voltages do not vary appreciably with the X/M ratio, and can be represented by a straight horizontal line equal to 175 percent for single-line-to-ground faults and 205 percent for double-line-to-ground faults. If protective devices are to be applied independent of conductor size, these maximum values should be considered as a basis for standardization. The voltages are expressed in percent of normal line-to-ground crest voltage and apply to systems in the 2400- to 13 800-volt range.



(a) 1L-G FAULTS

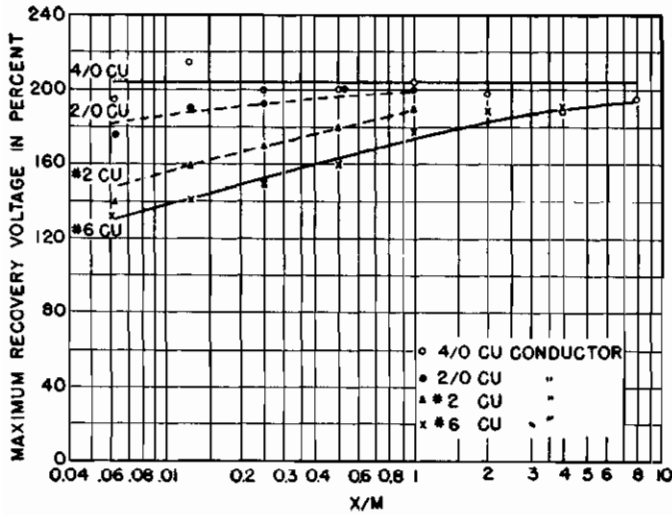

(b) 2L-G FAULTS

Fig. 28—Maximum recovery voltages as a function of X/M ratio.

X—Source reactance in ohms
M—Line length in miles

General Circuit Arrangements—The data in Figs. 27 and 28 are obtained for a source and a single line, which would be an exceptional condition in practice. It is therefore necessary to have available a definite procedure for estimating the voltage-recovery characteristics of the more practical systems, consisting of a multiplicity of trunk feeders and laterals. Guided by the results of analog computer studies of a few special cases, theoretical equations have been derived for estimating the voltage-recovery characteristics of practical systems, and are included in this section.

Studies⁷ were made of a system with 16 miles of line connected as (1) one 16 mile line, (2) two eight-mile lines in parallel, and (3) one four-mile line in parallel with one 12-mile line. The following conclusions were drawn from the data obtained:

1. The time to 90-percent voltage is a minimum with a single line.
2. The time to maximum recovery voltage is a minimum with more than one line in parallel.

Because of conclusion 2, calculations were made for the case of an infinite number of lines in parallel, by neglecting all line inductance and representing the lines by lumped capacitances. These data, for a single-line-to-ground fault on a two-ohm, 16-mile system are given in Table 5. The maximum voltages vary between 168 and

TABLE 5—CALCULATED RECOVERY-VOLTAGE DATA FOR A SOLIDLY-GROUNDED SYSTEM CONSISTING OF A TWO-OHM SOURCE AND 16-MILES OF LINE

Conductor Size	System	$T_{0.9}$	T_m	E_m
No. 6	3-wire	43.5	90	175
4/0	3-wire	47.3	95	168
No. 6	4-wire	45.3	94	183
4/0	4-wire	49.6	103	180

Note: The above data were calculated for a single-line-to-ground fault, neglecting loss and line inductance.

183 percent, and compare favorably with the 175 percent obtained in the general study for single-line-to-ground faults. The times to maximum voltage range between 90 and 103 microseconds, the shorter time being obtained with the smaller conductor on a three-wire system. The time to 90-percent voltage is also a minimum for this same system.

Whenever line inductance can be neglected, the significant recovery voltage times vary as \sqrt{XM} , where X is the 60-cycle source reactance and M is the total miles of connected line, assumed to be equal on the three-phases. Curve I, Fig. 27, is the calculated curve for times to maximum voltage for a single-line-to-ground fault on a No. 6-conductor, three-wire system. This straight-line curve approaches the analog computer data for X/M ratios above 1.0, even though the computer data were obtained for a single line, and the calculated curve applies for an infinite number of lines in parallel. This shows that line inductance has little effect on the times to maximum voltage for large X/M ratios. The significant time to maximum voltage for the case of a 4-mile line and a 12-mile line in parallel is plotted in Fig. 27. This point falls closer to Curve I than to the single-line curve. As most systems have a multiplicity of circuits, it is suggested that curve I be used for estimating times to maximum voltage, regardless of circuit arrangement. Curve II, Fig. 27, represents the times to 90-percent voltage for the case of an infinite number of parallel circuits. The times to 90-percent and maximum voltage, for the limiting case of an infinite number of feeders in parallel, can be estimated as follows:

- (1) $T_{0.9} = 7.7 \sqrt{XM}$ microseconds.
- (2) $T_m = 15.9 \sqrt{XM}$ microseconds.

Note: X is the 60-cycle source reactance (in ohms, and M is the connected overhead line in miles per phase, including trunk feeders and laterals. The constants in the equations were derived from the calculated times in Table 5 for a No. 6 conductor, three-wire system.

The computer data in Fig. 27 fall close to Curve II for X/M ratios larger than approximately 1/3. Below this

ratio, the times for a single line are not a function of line length, but only of source reactance. The minimum times were obtained for single-line-to-ground faults on the sending-end bus, and the recovery voltage reached the 90-percent values before reflections returned from the open end of the line. These times therefore vary directly with the 60-cycle source reactance, and follow Curve III.

With several long feeders in parallel, and a low source reactance, the times to 90-percent voltage are independent of line length, and vary directly with source reactance and with the number of feeders connected to the source bus. These cases can be represented in Fig. 27 by additional curves in parallel with Curve III, and with the times for a given X/M ratio increased directly with the number of parallel feeders. The times to 90-percent voltage for these long-line cases, where line reflections can be neglected, can be estimated from the following relation:

- (3) $T_{0.9} = 13.8 NX$, where X is the 60-cycle source reactance in ohms and N is the number of long feeders in parallel. The constant in the equation is the calculated time to 90-percent voltage for a system consisting of a one-ohm source and a single No. 6 copper overhead circuit.

In any particular case being studied, the time to 90-percent voltage should be calculated by Eqs. (1) and (3), and the minimum time thus obtained should be used. This procedure will give conservative results for systems normally encountered in practice.

9. Switching Surges and Arcing Grounds

The transient voltages discussed in the previous section were based on the opening of a circuit without restriking. Under some conditions restriking of the arc can occur, resulting in transient voltages of higher magnitude than produced with no restriking. Circuit changes that produce the highest transient voltages involve arc paths. The arc path may be in the fault or it may be in a circuit-interrupting device such as a circuit breaker. If the intermittent arcing takes place in a fault to ground, the phenomenon is called an arcing ground. However, if the arcing occurs in a circuit-interrupting device the voltages produced are called switching surges.

The mechanism by which intermittent arcs produce high transient voltages can best be explained by using simple circuits that are basically equivalent to actual power systems. Also it is convenient to represent the intermittent arc by a switch, the opening and closing of which is equivalent to the extinction and restriking of the arc, respectively. Using simple circuits, the mechanism of producing transient voltages will be explained for both arcing grounds and switching surges.

Arcing Grounds—Theory—The circuit in Fig. 29 illustrates the phenomenon during an arcing ground on a system. The windings of a three-phase generator are represented by simple T networks. The generator is assumed to be grounded through a neutral reactor, the reactance of which is large in comparison with the generator winding reactance. It is further assumed that an arcing fault occurs at the terminals of the generator. If, for the purpose of discussion, the unfaulted phases are

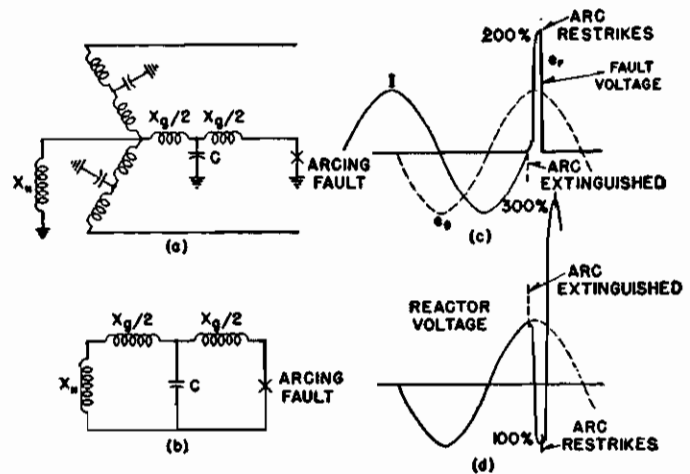

Fig. 29—Arcing fault at the terminals of a three-phase generator grounded through a neutral reactor.

- X_g —Reactance of generator winding
 C —Capacitance of generator winding to ground
 X_N —Neutral reactor
 I —Fault current
 e_f —Fault voltage
 e_g —Internal voltage of generator

neglected, the circuit in Fig. 29 (a) can be reduced to the simple circuit in Fig. 29 (b).

In the assumed circuit the fault current will lag the generated voltage by 90 electrical degrees as loss has been neglected. If the arc in the fault is extinguished at the instant the fault current passes through zero, as shown in Fig. 29 (c), the voltage across the fault will not immediately return to normal but will oscillate around normal. It will reach a crest of twice normal voltage, $\frac{1}{2}$ cycle of the high frequency oscillation after the arc is extinguished. This oscillation is the same as the simple oscillation discussed in connection with Fig. 16. During the fault, approximately full generated voltage appears across the neutral reactor as it has been assumed that the reactance of the neutral reactor is large in comparison to the machine reactance. Therefore at the instant the arc is extinguished in the fault, the voltage across the reactor is approximately equal to the crest value of the generated voltage. After the arc is extinguished the steady-state voltage across the neutral reactor is zero. The reactor voltage will therefore oscillate from a plus 100 percent voltage to a negative 100 percent voltage following arc extinction.

Now, if the voltage across the arc rises faster than the dielectric strength of the arc space recovers, the arc will restrike. This restriking of the arc can occur at any point on the wave of high frequency voltage across the arc. Suppose the arc restrikes when the voltage across the dielectric reaches its maximum value of twice normal. After the restriking occurs the fault voltage will drop to zero as shown in Fig. 29 (c). After the arc restrikes the steady-state voltage across the neutral reactor will be approximately equal to the crest value of the generated voltage. The reactor voltage will therefore start at a negative 100 percent voltage at the instant the arc is

reestablished and will oscillate around normal voltage, reaching a crest of three times normal.

In the above analysis it was shown that the voltage across the neutral reactor can reach three times normal line-to-ground voltage even when the arc is reestablished only once. This process can be repeated several times resulting in still higher voltages. In this analysis it was assumed that arcs were extinguished at zero points of the high-frequency current wave (except for the first extinction) and arcs were established at the crest of voltage waves. Other theories^{2,8} of arcing are based upon fundamental frequency arc extinction and restriking.

Switching Surges—Theory—The transient voltages produced during the de-energizing of an unfaulted line section are shown in Fig. 30 for a single-phase system in which the line is represented by a condenser. The successive steps of building up the capacitor voltage are shown in Fig. 30 (b). Normal capacitor voltage has been added as a dotted curve. The capacitor voltage is normal and at point A the switch is opened and a charge is left on the capacitor. The switch voltage is now the algebraic sum of the generated voltage and the voltage resulting from the charge on the capacitor. It will reach a maximum of twice normal generated voltage at one-half cycle of fundamental frequency after the switch is opened. At point B the capacitor voltage has a value of +1 in per unit values, whereas the normal capacitor voltage, with the switch closed, is -1. If the switch is

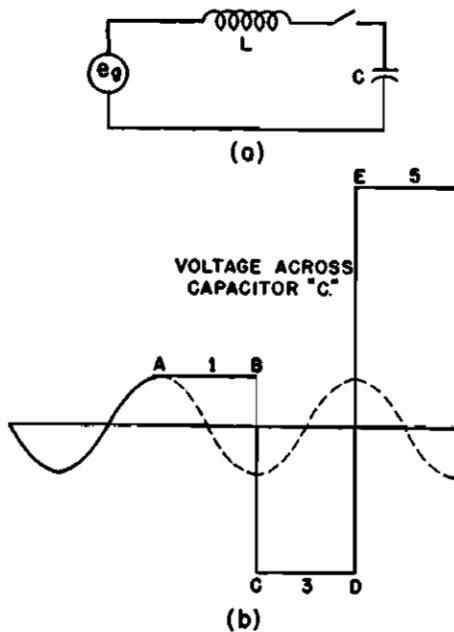

Fig. 30—De-energizing an unfaulted line section.

Note: Switch opened at A, C, E
Switch closed at B, D

closed at this time the capacitor voltage will tend to reach a value of -1 but because of the circuit inductance or inertia the voltage will overshoot and, without damping, will reach -3. If now the switch is opened, the capacitor will have a charge corresponding to a voltage of -3. If the switch is again reclosed one-half cycle after

opening, the capacitor voltage will tend to reach a value of +1 but will overshoot to +5. Thus the voltage builds up according to the series, 1, 3, 5, 7, . . . and will have no limit if damping is neglected. In this analysis it has been assumed that the inductance is small and that the natural frequency of the circuit is high in comparison to the fundamental frequency.

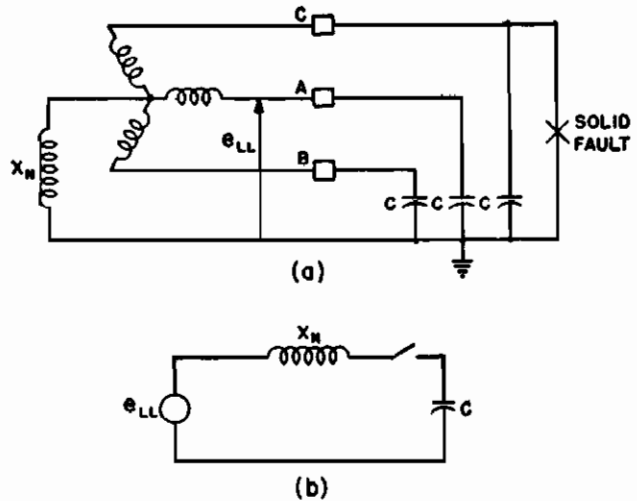

Fig. 31—De-energizing a line section subjected to a single line-to-ground fault.

A third important case is de-energizing a line section subjected to a single line-to-ground fault. Consider a solid single line-to-ground fault on phase C of the three-phase system in Fig. 31. Assume the fault is cleared by the opening of the circuit breaker with arcing in pole A. First, if X_N is large in comparison to the reactance of the generator, full line-to-line voltage will appear between phase A and ground, independent of whether pole A of the breaker is closed or open. For simplicity the three-phase system can be reduced to the circuit in Fig. 31 (b) in which the breaker is represented by a switch. Normal line-to-line voltage has been inserted back of X_N . The only difference between this circuit and the one in Fig. 30 is in the voltage back of the circuit reactance; the voltage in Fig. 30 (a) is normal line-to-neutral voltage and the voltage in 31 (b) is normal line-to-line voltage. The transient voltages produced in the circuit in Fig. 31 (b) will therefore be equal to $\sqrt{3}$ times the voltages produced in Fig. 30 (b). The voltage across the capacitor will then increase according to the series $\sqrt{3}$ (1, 3, 5, 7---).

Characteristics of Arc Path—In Fig. 32 is shown the voltage across the switch for the transient conditions in Fig. 30. The switch voltage is found by subtracting the condenser voltage from normal generated voltage. The first arc reestablishment occurs at A at twice normal voltage. This requires that the dielectric strength of the arc path recovers along some curve such as I, that is, along a curve above the curve of recovery voltage until at point A where they intersect. While the arc path is conducting, the dielectric strength of the switch is practically zero. When the arc is again extinguished, the dielectric strength curve again starts from zero but recovers much more rapidly and intersects the curve of

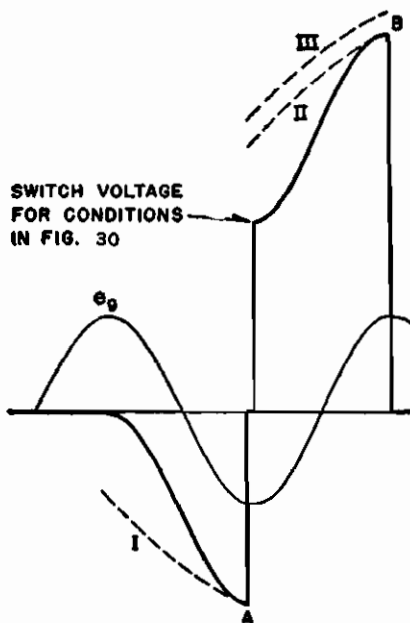

Fig. 32—Dielectric recovery characteristics assumed in Fig. 30.

recovery voltage at the point *B* causing a second restrike. If the dielectric strength of the arc path recovered along some curve *III* the arc would not reestablish at *B*. These curves show the requirement for the dielectric strength of the arc path to obtain high overvoltages. If curve *I* were not as high as shown, the restrike would have occurred at a lower voltage, and the capacitor voltage would not have been as large as shown in Fig. 30 (b). If the dielectric strength had built up at a more rapid rate, no restrike would have taken place. Thus, the dielectric strength must build up at a higher rate after any extinction than it did after the preceding extinction to develop cumulatively higher voltages. This phenomenon is unlikely to take place in open air between stationary contacts because such an arc path is unlikely to develop the required dielectric recovery strength. In confined arcs, where the pressure may increase after each conduction period, this phenomenon may take place. Separation of breaker contacts has a tendency to cause higher dielectric strength recovery rates after each conducting period because of the increasingly larger contact separation. These requirements of the arc path probably provide an explanation for the difficulties experienced in attempts to produce high voltages by arcing in air over insulator strings. The conditions for producing high voltages by intermittent arcing are somewhat more favorable for apparatus failure under oil than for flashover of an insulator string. Perhaps apparatus failure under oil causes line flashover instead of a line flashover causing apparatus failure.

General Study—The foregoing discussion has been based on simple circuits for the purpose of illustrating the essential elements of the theories of intermittent arcing. All actual systems are relatively quite complicated and cannot be reduced to the simple circuits used. Because of this complexity, the maximum voltages with intermittent arcing are not quite in accord with the pre-

ceding theories. More specifically, the maximum voltages are obtained for simple circuits with the arcs recurring at either the high-frequency voltage crest or at the fundamental-frequency voltage crest. With complicated circuits higher voltages may be obtained if the arc is established before or after these points. This is because the oscillating circuits have several natural frequencies. The determination of the exact manner of restriking is difficult to define analytically. Because of this fact and because of the importance of damping it is impractical to

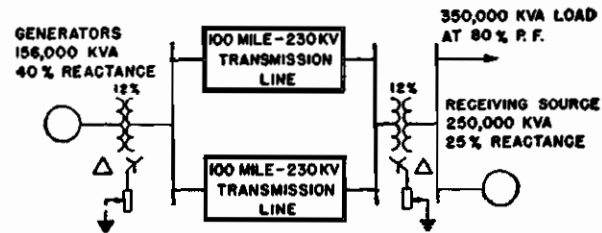

Fig. 33—Schematic diagram of system selected for study.

study arcing grounds and switching transients by the usual mathematical methods. It is more convenient to represent actual systems in miniature on the a-c network calculator and perform the switching operations with the special switches described previously.

To study the magnitude and other characteristics of transient voltages produced by switching operations and faults with intermittent arcing, a typical transmission system (Fig. 33) was selected for a study⁸ on the a-c network calculator. Since these transient voltages are greatly influenced by the method of grounding, the neutral impedances of the system were varied through a wide range of resistances and reactances, between the limits of the solidly grounded system and the ungrounded system.

The system consists of a hydroelectric generating station, the output of which is transmitted 100 miles over 230-kv lines to a load, which is also supplied by local steam generators. The sending and receiving-end transformers are star-connected on the 230-kv side to permit grounding, as discussed subsequently. The reactance characteristics of the different parts of the system are shown in Fig. 33 and the wire sizes and configuration of

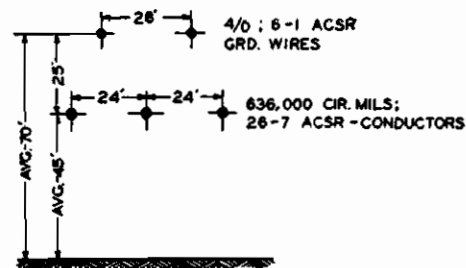

Fig. 34—Configuration of transmission line.

the transmission lines are shown in Fig. 34. The transmission lines are separated so there is no mutual effect between them. Also, the generators at both ends of the line are assumed to be in phase and to have the same internal voltage.

The general method of setting up the network calculator makes use of equivalent three-phase networks for each circuit element such as machines, transformers, and transmission lines. The character of these equivalent circuits is obvious and requires no comment except for the transmission lines, and these are represented by the circuit shown schematically in Fig. 35.

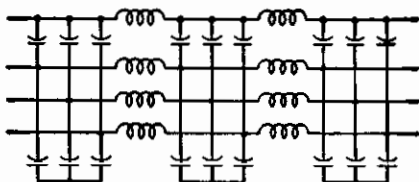

Fig. 35—Equivalent network used for representing each 230 kv transmission line of Fig. 33.

The highest voltages for a particular condition are sought throughout the investigation. In the arcing ground the fault is applied at the crest of the normal line-to-ground voltage and is then removed at the first current zero. The point of restriking is adjusted to give the maximum voltage for the number of restrikes considered. The fault is always removed at the first current zero following each arc recurrence. In the case of switching operations the circuit is initially opened at a fundamental current zero. The point of restriking is adjusted so as to give the maximum voltage for a given number of restrikes. The subsequent circuit openings are always assumed to take place at the first current zero following the arc reestablishment.

The highest voltages at the point of circuit change are always recorded. For example, for arcing-grounds the voltages are measured at the receiver end. On the other hand, in the case of de-energizing an unfaulted or faulted line, the voltages are measured at the sending end where the switching is done. When arcing grounds are considered on the system, several phase voltages as well as the neutral voltage are recorded. In the case of switching operations the voltages are recorded on the phase being switched, both on the line and supply sides as well as across the switch that is opening the circuit.

The voltages recorded are those occurring within $1\frac{1}{2}$ cycles of the first interruption considered. In some cases, either because of system loss or because of the relation of the natural frequency to the fundamental frequency, higher voltages may be experienced with one or no restrikes than with two or one restrikes, respectively. In some cases, particularly in the ground-fault neutralizer case, the voltages after the $1\frac{1}{2}$ -cycle period may continue to increase to a much higher steady-state voltage. With a ground-fault neutralizer quite high voltages are obtained if the circuit is in tune at fundamental frequency and a residual voltage is produced as by some unbalance. For example, the opening of one phase of a system subjected to a three-phase or a line-to-line fault on the phase being opened will produce a steady-state voltage of many times normal.

In this investigation of transient overvoltages produced by switching operations and faults, four principal cases have been selected for study as follows:

1. Arcing-ground conditions on one phase to ground.
2. De-energizing an unfaulted line, one pole unit opening and two remaining closed.
3. De-energizing an unfaulted phase with a ground fault on one of the other phases, one pole opening and the other two remaining closed.
4. De-energizing an unfaulted phase with a ground fault on the two other phases, one pole opening and the other two remaining closed.

In general, arcing-ground conditions are for a fault on one phase. De-energizing a line section is considered more important than energizing because for the latter the intermittent arcing is limited in duration by the closing of the switch. In the case of opening the faulted lines it is assumed that the unfaulted phase opens before the pole units of the faulted phase or phases. Such an assumption is based on the ability of the switch to recover dielectric strength at a high rate. This assumption tends to give higher magnitudes of transient voltage. If the pole unit in the sound phase tends to open after the fault is cleared, then the voltages will be similar to those produced when an unfaulted line is de-energized. The voltages will range between these limits as the time of relative opening is varied. The conditions selected for study illustrate possible circuit-breaker operations on an actual system.

In this study the transient voltages are obtained for the conditions corresponding to both one and two restrikes. This number of restrikes may be taken as the equivalent of a larger number with the earlier restrikes taking place so quickly that they do not contribute much to the voltage magnitude.

One of the variable factors considered is the method of system grounding that includes both resistances and reactances between the limits of a solidly grounded system and an ungrounded system. When the system is solidly grounded, the transformer at the sending end is solidly grounded when one line is in operation, and the transformers are solidly grounded at both ends when two lines are in operation. In the case of impedance grounding a reactor or resistor of varying ohmic value is considered in the neutral-to-ground circuit at the sending end when one line is in operation, and a reactor or resistor of equal magnitude is considered in the circuit in the sending and receiving ends when two lines are in operation. The ohmic values plotted on the figures to be discussed later are the actual ohms considered in the ground connection at one point. For example, 50 ohms on a system with one ground point is the resistance or reactance considered in the sending end ground. When two lines are considered in operation, 50 ohms corresponds to the ohms in the sending-end neutral connection and a like value in the receiving-end neutral connection.

Results of General Study—The results of the a-c network calculator study are presented in graphical form in Figs. 36 to 39 inclusive. They give the transient voltages expressed in percent of the normal line-to-ground voltage crest and are plotted as a function of the reactance or resistance in the neutral connection. The solid-line curves are for reactance grounding and the dotted-line curves are for resistance grounding. The neutral

reactance corresponding to a ground-fault neutralizer is indicated. In each of these figures the data is plotted for one and two lines and one and two restrikes.

As shown in Fig. 36 transient voltages can be avoided by the use of the solidly-grounded system or the system grounded through a ground-fault neutralizer, both of

for a free-neutral system the voltages are appreciably lower for the larger lengths of connected line.

The transient voltages for the condition of de-energizing a line section with a fault on a phase other than that which is being switched are shown in Fig. 38. The voltages in all cases of reactance grounding increase as the neutral reactance increases. The voltages between neutral point and ground also increase for resistance grounding as the magnitude of the resistance is increased. The voltages with a ground-fault neutralizer are definitely higher than for any of the lower values of reactance grounding. This is to be contrasted with the dip in the voltage curves of Figs. 36 and 37. In Fig. 38 the voltages with two restrikes increase as compared to the case with one restrike. As would be expected, the longer the connected line, the lower the magnitude of the transient voltages.

Figure 39 shows the results of a study similar to that of Fig. 38 except that a double instead of a single line-to-ground fault is applied to the line section being de-energized. In general, the comments are the same as for

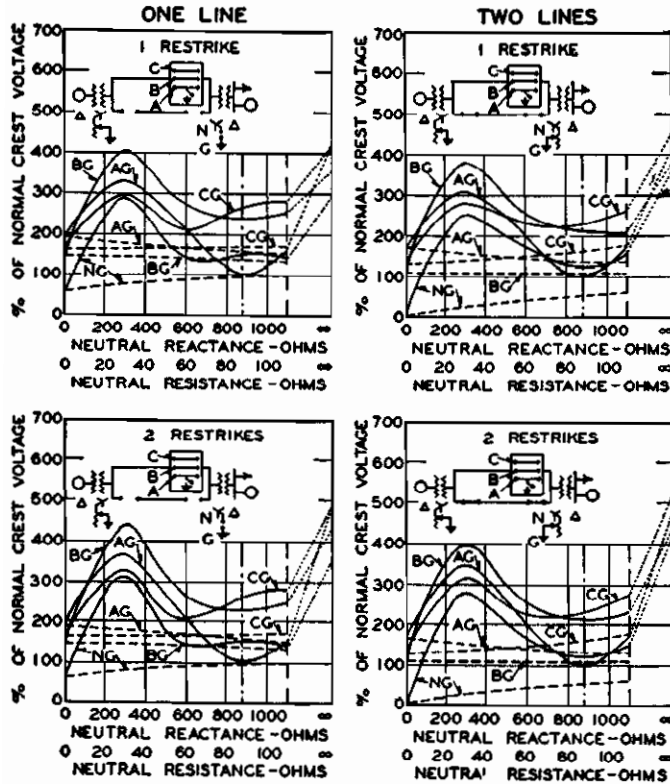

Fig. 36—Effect of grounding impedance on transient voltages caused by arcing grounds.

Solid curve: Reactance grounding
 Dotted curve: Resistance grounding
 Note: Letters on curves refer to lettered points on inset circuit.
 Ground-fault neutralizer reactance: 875 ohms

which have been employed for many years to avoid the abnormal voltages encountered on ungrounded systems. The voltages corresponding to resistance grounding are fairly uniform and relatively low for the range of resistance studied. However, for neutral resistances approaching infinity, the transient voltages will approach those of the ungrounded system. The study shows that there is a value of reactance intermediate between the solidly grounded system and the system grounded through a ground-fault neutralizer almost as high as for the ungrounded system.

The transient voltages resulting from the de-energizing of an unfaulded line are shown in Fig. 37. The lowest transient voltages, with the exception of those across the neutral impedances, are obtained for a system grounded through a ground-fault neutralizer. In all cases the neutral-point voltage increases as the neutral impedance increases. For the range of practical neutral impedances, there is no appreciable difference between the voltages obtained for the case of one and of two lines. However,

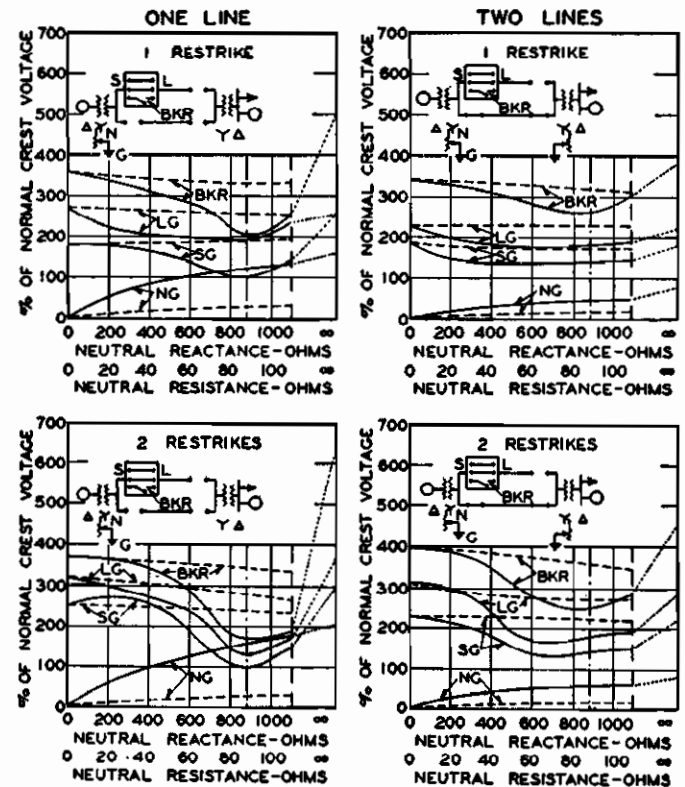

Fig. 37—Effect of grounding impedance on transient voltages caused by de-energizing an unfaulded line
 See subcaption of Fig. 36.

the case of Fig. 38. For reactance grounding the transient voltages increase rapidly for a relatively small addition of neutral reactance, so that for low neutral reactances the transient voltages closely approach those of the free-neutral system.

The results obtained in the a-c network calculator studies are based on a definite number of restrikes which are spaced at such intervals as to give the maximum volt-

age for this number of restrikes. Thus, in the average case, since the restrikes may not occur at the optimum point, the voltages will be of lower magnitude giving a probability curve for the voltage. Of course, only a minority of the cases of system faults and switching produce abnormal voltages.

The a-c network calculator studies have also been based on the assumption that transient voltages of increasing magnitude can be impressed on the system without altering the characteristics of the system. Actually, the transient voltages will be limited by other factors that become of increasing importance as the transient voltage increases. On some systems corona will limit the magnitude of transient voltage by introducing losses in the oscillating circuits. Under some conditions excess

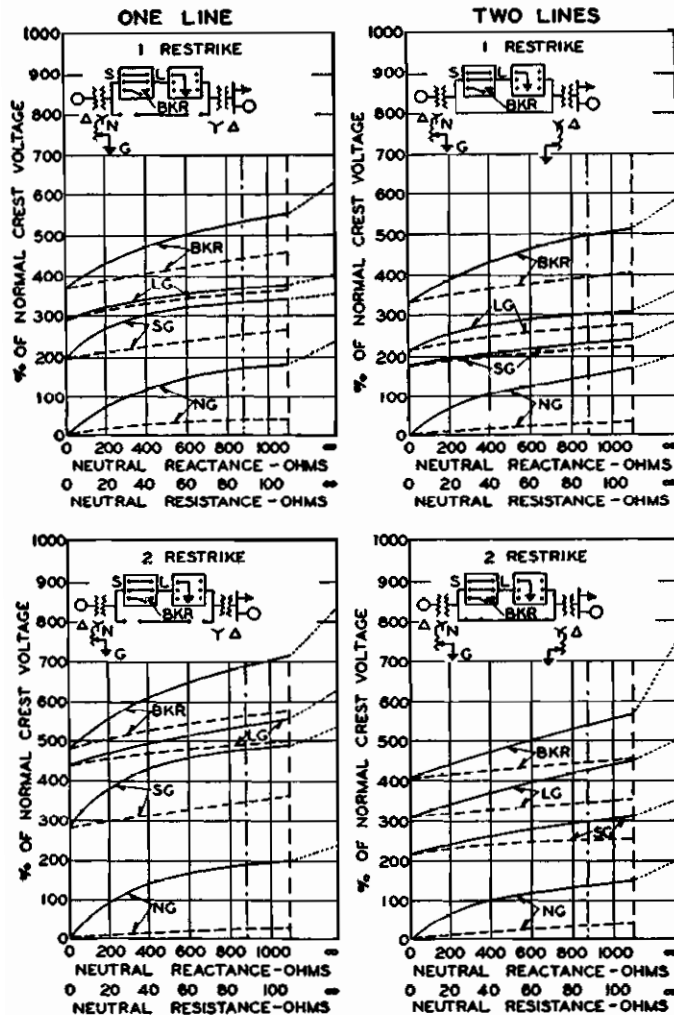

Fig. 38—Effect of grounding impedance on transient voltages caused by de-energizing line with single line-to-ground fault See subcaption of Fig. 36.

voltages will produce increases in exciting current particularly at the lower frequencies, but usually this factor is unimportant. Transient voltages can also be limited by the operation of lightning arresters or protective gaps adjusted to operate below the flashover level of line or apparatus insulation. These devices may limit the magni-

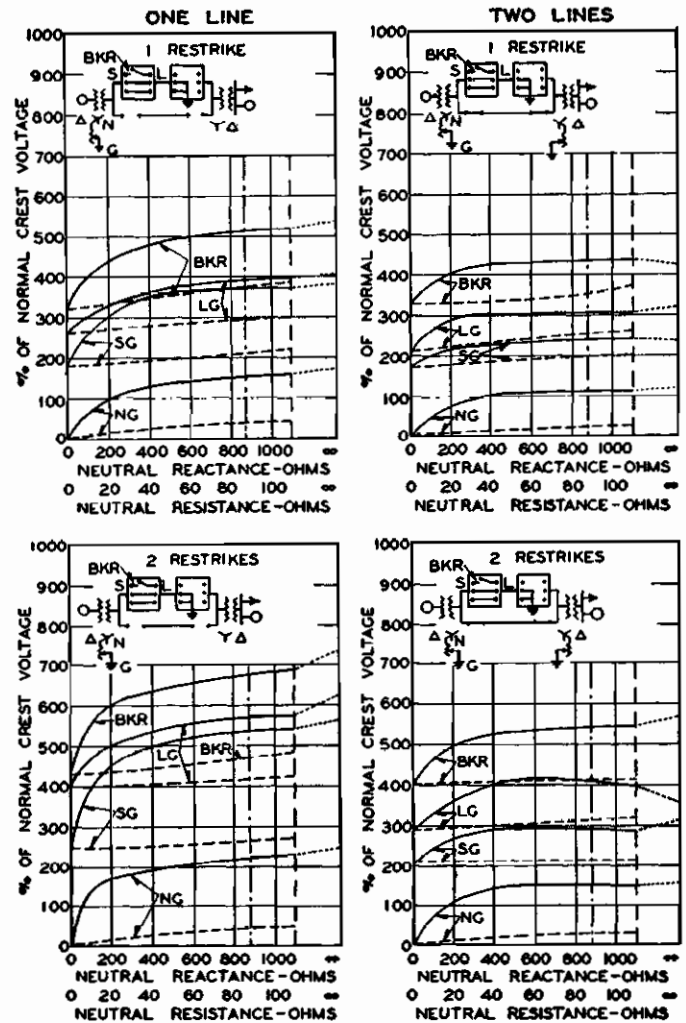

Fig. 39—Effect of grounding impedance on transient voltages caused by de-energizing line with double line-to-ground fault See subcaption of Fig. 36

tude of transient voltages on a particular system. Finally, the transient voltage is limited by the flashover characteristics of line and apparatus insulation. Operating experience confirms the results of this study in that some switching operations do result in flashover of line or neutral-point insulation.

Many klydonograph investigations have been reported in the literature, and frequently overvoltages resulting from switching operations are segregated from those due to lightning. Extensive investigations were reported by Cox, McAuley, and Huggins,⁹ Gross and Cox,¹⁰ Lewis and Foust,¹¹ and by some European investigators. The Joint Subcommittee on Development and Research of the Edison Electric Institute and Bell Telephone System, has also carried on investigations and has made an excellent summary¹² of the more important published data.

The principal results of the switching-surge studies using the klydonograph have been summarized in Fig. 40. Curves A and B, obtained from the original investigation by Cox, McAuley, and Huggins, give the voltages caused by energizing or de-energizing operations and the voltages resulting from faults with subsequent switching,

respectively. Curve C gives a summary derived from the work of Lewis and Foust. In order to give a more suitable scale for plotting the results of the surge studies all the surges of a magnitude less than twice normal have been disregarded. The Lewis and Foust paper, however,

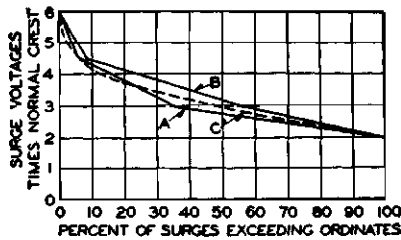

Fig. 40—Distribution of surge voltages caused by switching and faults.

- A—Switching surges—Cox, McAuley, and Huggins
- B—Surges from faults—Cox, McAuley, and Huggins
- C—Switching surges—Lewis and Foust
- A and B—Eighteen systems—1925 to 1926
- C—Fourteen systems—1926 to 1930

shows that of all the reported surges above normal voltage, 45 percent were above twice normal. Fig. 40 shows that the limiting value of the surges is about six times normal crest voltage, 5 percent exceed five times normal, and 20 percent exceed four times normal. These results show that there is an upper limit to the voltage recorded, indicating the possibility of some limiting factor. Fig. 41 shows the ratio of flashover voltage to the normal crest voltage, for transmission lines of different voltages. The shape of the curve of Fig. 40 compared with the data given in Fig. 41 indicates that the magnitude of switching

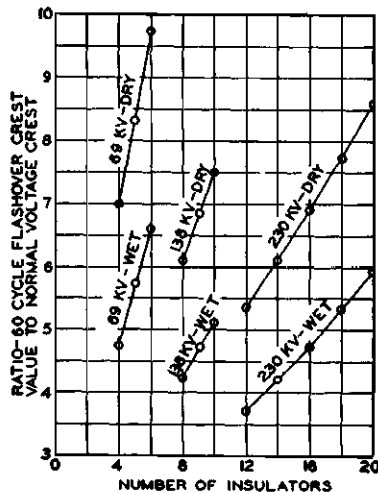

Fig. 41—60-cycle flashover voltage ratios for 10-inch suspension insulators.

surges recorded could be limited by line flashover. While it is undoubtedly true that a considerable portion of these switching operations occur with relatively little energy in the oscillation and at relatively high frequency, it is also true that as systems expand the natural frequency of systems for switching operations decreases

and the amount of energy in these oscillations increases. Thus, these factors tend to increase the importance of switching surges.

The maximum voltages of Figs. 36 to 39 correspond closely with the limiting voltage of six times normal indicated in Fig. 40. The shape of the curves of Fig. 40 should probably not be accepted too freely as these are no doubt influenced by the flashover of lines or apparatus, or the operation of lightning arresters.

10. Effect of Generator Grounding on Transient Voltages

The results of the general study of transient overvoltages produced by switching and faults in the preceding section were based on the assumption that there was no appreciable arc drop and that the arc was always extinguished at a current zero, either fundamental or high-frequency. In some cases, especially in low-voltage circuits, additional characteristics of an arc must be considered because of their influence on transient voltages.

Arc Characteristics—Prior to the actual interruption of the arc in a circuit breaker there is a voltage drop between the breaker terminals. The magnitude of this drop varies for different types of breakers, being lower for the higher voltage circuit breakers when expressed in percent of system voltage. This drop is of two parts, first an arc drop that is fairly uniform in magnitude and lasts during the entire arcing period, and second, a drop that is a function of the efficiency of arc interruption and the current being handled. Fig. 43 shows a fairly uniform breaker voltage until the arc is ruptured at which time the voltage increases quite rapidly to a negative crest of approximately normal line-to-ground crest voltage. This negative crest voltage is commonly referred to as the breaker "extinction voltage." An analysis made of oscillograms of many breaker operations indicates that for a circuit breaker opening 12 000 and 13 200-volt circuits this "extinction voltage" may be as large as 125 percent of the normal line-to-ground crest voltage but is usually much lower. This extinction voltage is produced by extinction of the arc before a normal current zero, that is, before the current in the arc would normally pass through zero.

In general, the same characteristics as mentioned above are found in all arcs under oil or in confined spaces, such as arcs caused by flashover of apparatus under oil, in cables, etc. Arcs between stationary contacts in air will usually have entirely different characteristics because no large de-ionizing agent is present.

Effect of Extinction Voltage on Transient Voltages—The system in Fig. 42 will be used in presenting the theory involved in the production of transient voltages by switching or arcing grounds. In this circuit the generator windings are represented by simple *T* networks and additional capacitance is added at the machine terminals to represent the capacitance of connected feeders. The positive, negative, and zero-sequence reactances of the generator and feeders are assumed to be equal. The generator is grounded through a neutral reactor, and a single line-to-ground fault is assumed on a feeder outside of a breaker. The effect of the unfaulted phases on the

transient voltages can be neglected, reducing the circuit to the one shown in Fig. 42 (b).

Consider the case of a single line-to-ground fault occurring on a feeder and the fault removed by operation of the breaker. The fault is assumed to last long enough to allow damping out of all initiating transients and the

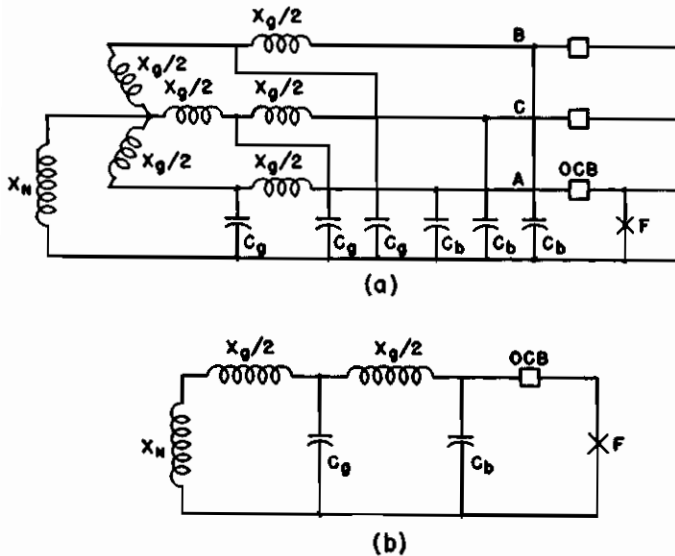

Fig. 42—Generator grounded through neutral reactor.

- (a) Simple three-phase system
- (b) Simplified single-phase system
- X_g —Generator subtransient reactance
- C_g —Generator winding capacitance to ground
- C_b —Capacitance of bus, cables, etc.
- OCB—Oil circuit breaker
- F—Fault
- X_N —Neutral reactor

arc in the breaker is ruptured far enough ahead of a normal current zero to give an extinction voltage equal to normal line-to-ground crest voltage. The generated voltage and fault current are shown in Fig. 43 for this condition. A small arc drop in phase with the current appears across the breaker terminals during the entire arcing period.

If the neutral reactance is large in comparison to the machine reactance, practically all of the generated voltage will appear as a drop across the neutral reactor while the fault is present. The reactor voltage will then be approximately equal to the generated voltage until the breaker terminal voltage starts to increase as a result of the de-ionizing action of the breaker. As the neutral reactor was assumed to be large in comparison to the machine reactance, the reactor voltage is approximately equal to the difference between the generated voltage and the breaker voltage. It therefore reaches a crest of twice normal at A'. If the arc is ruptured* at A, normal generated voltage is removed from the reactor as with no fault on the system no voltage appears across the neutral reactor. The reactor voltage therefore oscillates around

*In this analysis the arc is assumed to be ruptured at the instant of crest negative voltage between breaker terminals. It is realized that the arc may be ruptured before this time.

zero; and without damping it would reach a negative crest of twice normal. With damping it reaches a negative crest somewhat less as shown in Fig. 43.

With the breaker open and with the fault on the system, the normal steady-state voltage across the breaker is approximately equal to the generated voltage. When the arc is ruptured at A the breaker voltage will start at a negative crest of 100 percent and oscillate around the generated voltage. It will reach a positive crest of three times normal with no damping or some less with damping.

The maximum reactor voltage is equal to the breaker extinction voltage plus the generated voltage at the time this extinction voltage appears across the breaker terminals. In the case of a reactance grounded generator the arc is ruptured at near crest generated voltage so the reactor voltage is equal to the extinction voltage plus normal crest generated voltage. The breaker voltage approaches a crest equal to twice the generated voltage plus the extinction voltage.

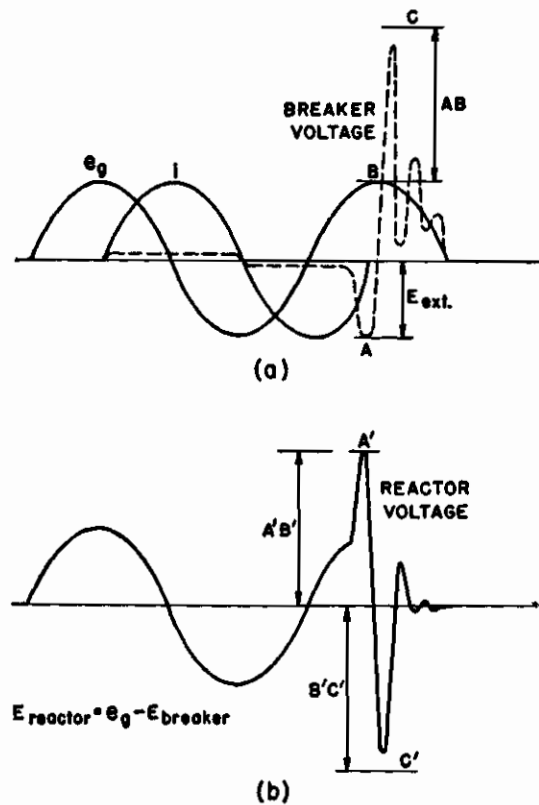

Fig. 43—Transient voltages with no restriking.

- (a) Breaker voltage.
- (b) Reactor voltage
- e_g —Normal line-to-ground voltage
- E_{ext} —Extinction voltage
- i —Fault current

As shown in Fig. 43, the breaker voltage may build up fairly high. If at any time this voltage exceeds the dielectric strength of the arc space between the breaker contacts, the arc will restrike. In Fig. 44 the restriking is assumed to occur at the instant the breaker voltage reaches its maximum value at C. Assuming that 100

percent extinction voltage appeared across the breaker terminals at the instant of arc rupture and further assuming no damping, this maximum breaker voltage will be three times normal. When the breaker voltage is at C the reactor voltage will be at a negative 200 percent voltage. When the arc is reestablished the breaker voltage will decrease to a very small arc drop as shown in Fig. 44. After the restrike occurs the steady state voltage across the reactor is approximately equal to the normal generated voltage. The reactor voltage will therefore start at C' and oscillate around normal generated voltage. It will overshoot to a crest voltage of four times normal if losses are neglected.

With one restrike and without damping the reactor voltage will reach three times normal crest generated voltage plus the breaker extinction voltage. With additional restrikes the voltage can increase further if the restrikes occur at the right time. It is of course rather

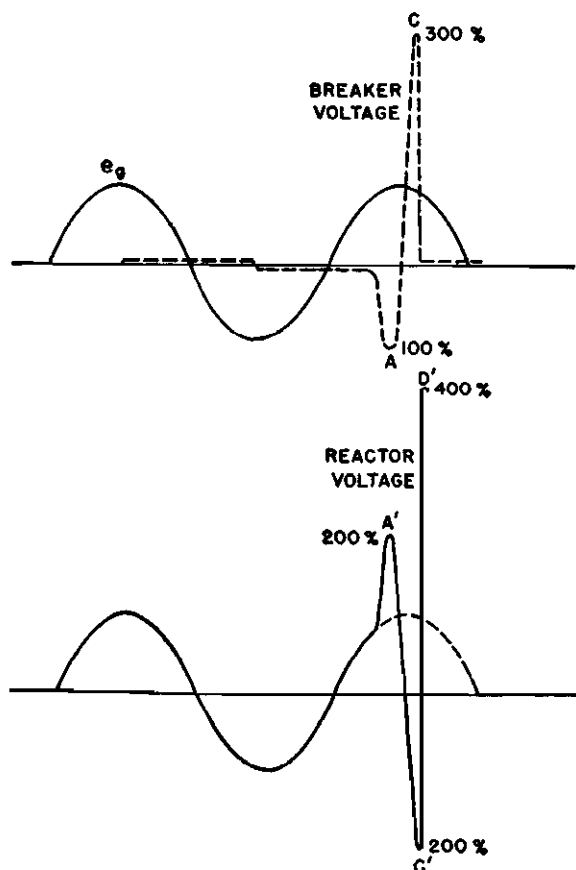

Fig. 44—Transient voltages produced with restriking.

improbable that more than one or two restrikes will occur at just the right time to give these high overvoltages.

Resistance Grounding—If the neutral reactor is replaced with a resistor having the same impedance, the power factor of the fault circuit will be approximately unity. The breaker and resistor voltages for this condition are shown in Fig. 45. Normal current zero will coincide with normal voltage zero. As the arc drop is still in phase with the current, the breaker extinction voltage and normal generated voltage are on the same side of the

axis. As the resulting breaker voltage oscillation after the arc is ruptured at A depends upon the generated voltage, the oscillations will be quite small. No voltage appears across the resistor at the time the arc is ruptured because no current is flowing at that time. The oscillation in the resistor voltage will be small and will be

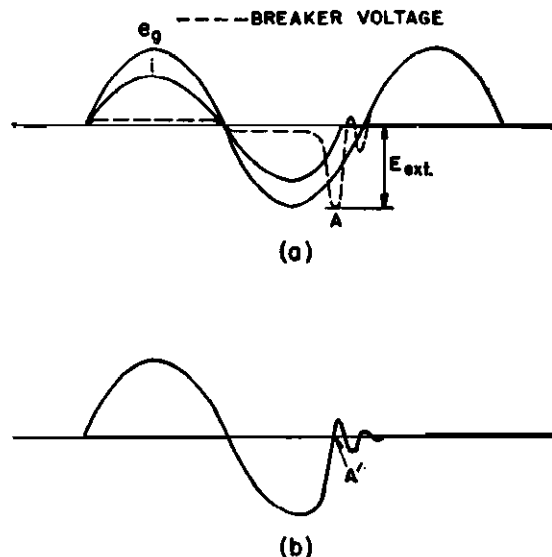

Fig. 45—Transient voltages produced with resistance grounding.

- (a) Breaker voltage
(b) Voltage across neutral resistor

damped out rapidly because of the high loss present in the system.

Parallel Resistance and Reactance—Since fairly high voltages can be produced when a neutral reactor is used and since these voltages are greatly reduced when a neutral resistor is used, the question naturally arises as to whether it would be possible to compromise and use a combination of both. With resistance and reactance in parallel the phenomenon will follow closely one of the cases above depending upon which predominates. Resistance in parallel with a reactor will usually prevent cumulative building up of the reactor voltage on successive restrikes but a low parallel resistance is necessary in order to prevent the breaker extinction voltage from appearing across the neutral reactor. As shown in Fig. 43 the reactor voltage is the sum of the generated voltage and the extinction voltage. Because the resistance required to keep most of the extinction voltage from appearing across the neutral reactor is small, it is usually preferable to omit the reactor entirely and use resistance grounding.

Analog Computer Studies—In the theoretical discussion given above the neutral reactance was assumed to be much larger than the machine reactance. To show the effect of variations in transient voltages with neutral reactance, studies were made on the analog computer. The circuit employed was similar to the one in Fig. 42(a) excepting that the oil circuit breaker was omitted, and an arcing fault was applied between phase A and ground

TABLE 6—SURGE VOLTAGES PRODUCED WITH REACTANCE GROUNDING

X_0/X_1 Ratio	Surge Voltages*					
	Faulted Phase		Unfaulted Phases		Across Neutral Reactor	
	One Restrike	Two Restrikes	One Restrike	Two Restrikes	One Restrike	Two Restrikes
1	170	170	160	100	0	0
2	165	168	140	142	45	45
3	165	165	180	193	100	100
4	165	165	190	215	115	130
6	185	185	200	230	150	155
8	190	190	260	260	180	180
10	280	430	285	400	175	270
12	...	460	...	450	...	300
14	400	440	390	490	250	350
20	390	400	410	450	250	270
30	370	400	390	500	250	300
50	330	370	400	430	230	300
100	280	260	400	410	230	280

*Expressed in percent of normal line-to-ground crest voltage.

at the generator terminals. The following constants were used:

$$X_g = 1.28 \text{ ohms at 60 cycles.}$$

$$C_g = 0.35 \text{ microfarad.}$$

$$C_b = 0.20 \text{ microfarad.}$$

The fault was applied at the instant the 60-cycle voltage between phase A and ground was equal to its crest value, and removed at the first current zero, either 60-cycle or high frequency. The fault was reapplied at crest recovery voltage across the fault and then removed at the first current zero following the restrike, or fault re-application. In the case of two restrikes the latter procedure was repeated. Table 6 is a summary of the results obtained with one and two restrikes for X_0/X_1 ratios between one and 100. In this table X_1 is equal to X_g in Fig. 42, and X_0 is equal to X_g plus $3X_n$, the positive- and zero-sequence machine reactances being equal in the equivalent circuit employed. The faulted phase, maximum unfaulted phase and neutral reactor voltages are included in the summary.

In making these studies it was noted that the magnitude of the transient voltages was influenced to a large extent by the presence or absence of high-frequency current zeros following the fault application or a restrike. With an X_0/X_1 ratio of eight, there was no high-frequency current zero, even following a restrike, and the circuit-opening operation was delayed until the 60-cycle current went through zero. As considerable time was available for dissipation of transient energy between circuit-closing and circuit-opening operations, the transient voltages did not exceed 260 percent with two restrikes. Increasing the X_0/X_1 ratio to ten gave a high-frequency current zero following the first restrike, permitting a circuit-opening operation without waiting for a 60-cycle current zero. In

this case the maximum voltage was recorded as 430 percent. These results show that it would be desirable to limit the X_0/X_1 ratio to some value less than ten, in order to rule out the possibility of obtaining the excessive transient voltages associated with the larger X_0/X_1 ratios. More fundamentally an X_0/X_1 ratio should be selected that does not produce a high-frequency current zero following a restrike. If this condition is met, the voltages is not appreciably higher with two restrikes than with one, and no cumulative build-up of voltages is possible with successive restrikes.

The results in Table 6 were obtained by removing the fault at a current zero, that is, without forcing current zero. If the fault is in a confined space, such as under oil or in apparatus or cable insulation, the deionizing agents present may produce a rapid increase in arc drop, with the result that the fault is interrupted prior to a normal current zero. This forcing of a current zero increases the transient voltages as was discussed in connection with Figs. 43 and 44. It also increases the magnitude of the high-frequency current following a restrike, which decreases the X_0/X_1 ratio required to produce a high-frequency current zero following a restrike. This makes it difficult to select a suitable maximum X_0/X_1 ratio for application purposes because the ratio is influenced by the magnitude of the arc-extinction voltage assumed. As discussed above under arc characteristics, circuit breakers opening 12 000 and 13 200 volt circuits may infrequently have extinction voltages somewhat larger than normal line-to-ground crest voltage. Similar data are not available for fault arcs because this information is extremely difficult to obtain primarily because of the probability nature of the phenomenon.

To obtain some idea of the influence of arc-extinction voltage on the transient voltages produced by an arcing ground on a reactance grounded system, a special study was made on the computer using the same circuit and constants as above. A line-to-ground fault was applied at the

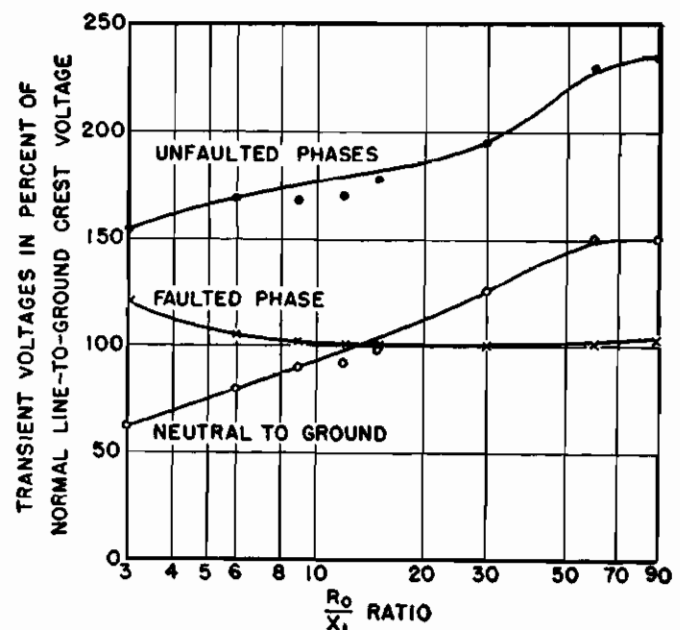

Fig. 46—Transient voltages with resistance grounding.

instant the 60-cycle voltage between phase A and ground was equal to its crest value, and removed approximately one-half cycle later. The circuit was opened slightly ahead of a normal 60-cycle current zero to give 100-percent extinction voltage. The fault was re-applied at crest recovery voltage across the fault. It was noted that no high-frequency current zero occurred following the restrike, with an X_0/X_1 ratio of four, but that such a zero was present with a ratio of six. The transient voltages did not exceed 260 percent with the ratio of four.

This analysis shows that the maximum transient voltages with reactance grounding are influenced by the X_0/X_1 ratio and by arc-extinction voltage. If the transient voltages are to be limited to 250 or 260 percent of normal line-to-ground crest voltage, the X_0/X_1 ratio should be limited to eight or four depending upon whether zero or 100-percent extinction voltage is assumed. In generator circuits, where faults can occur in confined spaces, it is suggested that the X_0/X_1 ratio be limited to three. This limit permits the application of 80-percent lightning arresters, and allows for arc-extinction voltages somewhat larger than normal line-to-ground crest voltage.

Studies were made for the case of a generator grounded through a resistor of 98 percent power factor. The circuit and constants were the same as used in the studies of reactance grounding. The results for two restrikes are summarized in Fig. 46. for R_0/X_1 ratios between 3 and 90. Although the data are based on two restrikes, there is no appreciable difference between the results with one and

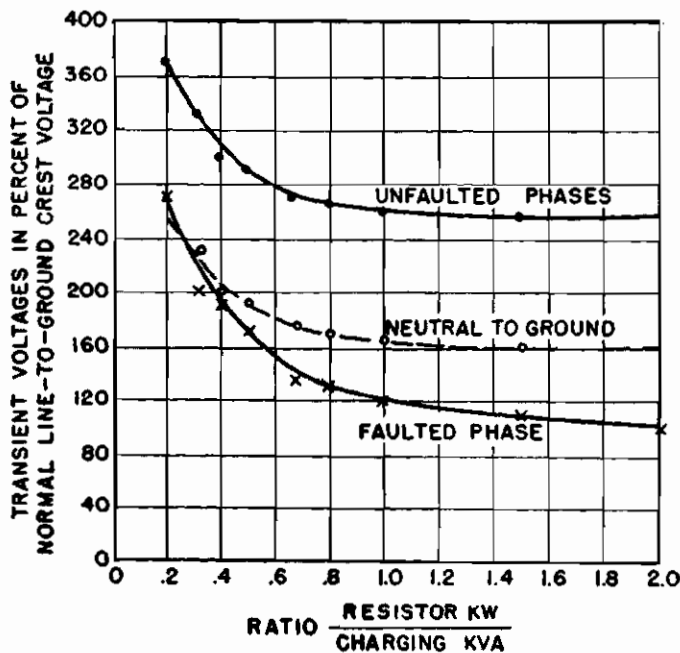

Fig. 47—Transient voltages with high-resistance grounding.

two restrikes. The fault to ground was always removed as the 60-cycle current went through zero because there were no high-frequency current zeros over the entire range of R_0/X_1 ratios considered. The transient voltages do not exceed 235 percent of normal line-to-ground crest voltage for any ratio considered.

Computer studies were also made with the same system grounded through the primary winding of a distribution transformer, having a resistor across the secondary winding as shown in Fig. 29 of Chap. 19. The transient voltages for this case are summarized in Fig. 47. The results are plotted as a function of the kilowatts loss in the resistor

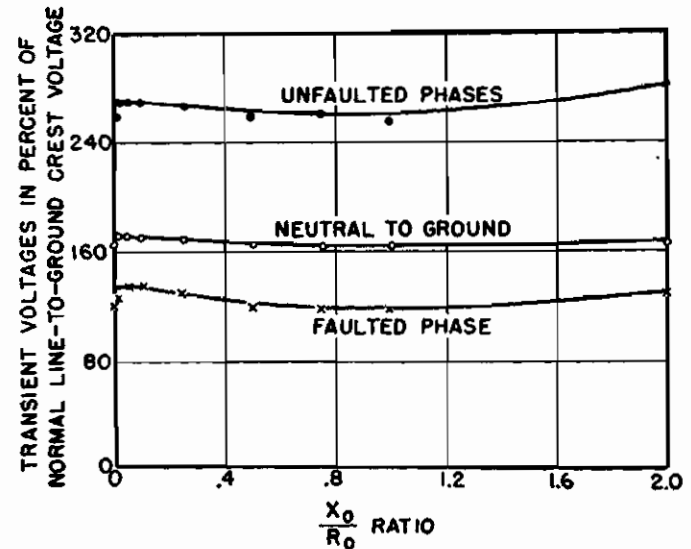

Fig. 48—Influence of reactance on transient voltages obtained with high-resistance grounding.

during a single-line-to-ground fault and the three-phase charging kva of the system during normal operation. Ratios of resistor loss to charging kva of one and larger will limit the transient voltages to approximately 260 percent of normal line-to-ground crest voltage.

The data in Fig. 47 are based on a resistor having unity power factor and a transformer having zero reactance. Practical resistors and transformers introduce reactance in the zero-sequence circuit. To show the effect of this reactance, studies were made for X_0/R_0 ratios of zero to two. The resistor loss-to-charging kva ratio was made equal to unity in this study. The results in Fig. 48 show that practical values of reactance have little influence on the transient voltages obtained.

REFERENCES

1. *Symmetrical Components* by C. F. Wagner and R. D. Evans (a book), McGraw-Hill Book Company, Inc., New York, 1933.
2. *Voltages Induced by Arcing Grounds*, by J. F. Peters and J. Slepian, A.I.E.E. *Transactions*, Vol. 42, April 1923, pages 478-493.
3. *The Klydonograph*, by J. F. Peters, *Electrical World*, April 19, 1924, pages 769-773.
4. *System Recovery Voltage Determination by Analytical and A-C Calculating Board Methods*, by R. D. Evans and A. C. Monteith, A.I.E.E. *Transactions*, Vol. 56, June 1937, pages 695-703.
5. *A Large-Scale General-Purpose Electric Analog Computer*, E. L. Harder and G. D. McCann, A.I.E.E. *Transactions*, Vol. 67, 1948, pages 664-673.
6. *Recovery Voltage Characteristics of Typical Transmission Sys-*

- tems and Relation to Protector-Tube Applications, by R. D. Evans and A. C. Monteith, *Electrical Engineering*, Vol. 57, August 1938, pages 432-443.
7. Voltage-Recovery Characteristics of Distribution Systems, R. L. Witzke, A.I.E.E. Technical Paper 49-53, 1949.
 8. Power System Transients Caused by Switching and Faults, by R. D. Evans, A. C. Monteith and R. L. Witzke, *Electrical Engineering*, Vol. 58, August 1939, pages 386-394.
 9. Klydonograph Surge Investigations, by J. H. Cox, P. H. McAuley and L. G. Huggins, A.I.E.E. *Transactions*, Vol. 46, February 1927, pages 315-329.
 10. Lightning Investigation on the Appalachian Electric Power Company's Transmission System, by I. W. Gross and J. H. Cox, A.I.E.E. *Transactions*, Vol. 50, September 1931, page 1118.
 11. Lightning Investigation on Transmission Lines—II, W. W. Lewis and C. M. Foust, A.I.E.E. *Transactions*, Vol. 50, September 1931, pages 1139-1146.
 12. Overvoltages on Transmission Lines Due to Ground Faults as Affected by Neutral Impedances. Engineering Report No. 30, Joint Subcommittee on Development and Research, Edison Electric Institute and Bell Telephone System, November 15, 1934.
 13. Reactance or Resistance Grounding? R. L. Witzke, *Electric Light and Power*, August 1939, pages 42-45.

WAVE PROPAGATION ON TRANSMISSION LINES

Original Authors:

C. F. Wagner and G. D. McCann

Revised by:

C. F. Wagner

I. SIMPLE WAVES

A TRANSMISSION line can be regarded as made up of elements. If resistance is neglected, each element consists of a shunt capacitance and a series inductance as shown in Fig. 1. If a voltage is applied to one end of such a line, the first capacitor becomes charged immediately to the instantaneous applied voltage. However,

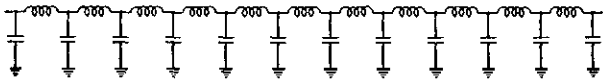

Fig. 1—Transmission line broken up into small elements.

because of the first series inductor, the second capacitor does not respond immediately but is delayed. Similarly, the third capacitor is delayed still more by the presence of the second inductor. Thus the farther removed from the end of the line the greater the delay. If the applied voltage is in the form of a surge, starting from zero and returning again to zero, it can be seen that the voltages on the intermediate condensers rise to some maximum value and return again to zero. The disturbance of the applied surge is thus propagated along the line in the form of a wave.

1. Mechanical Analogy

It can be shown with mathematical rigor that for a system of the kind just postulated (without series or shunt resistances and zero ground resistivity) the wave will be propagated along the line with undistorted or undimin-

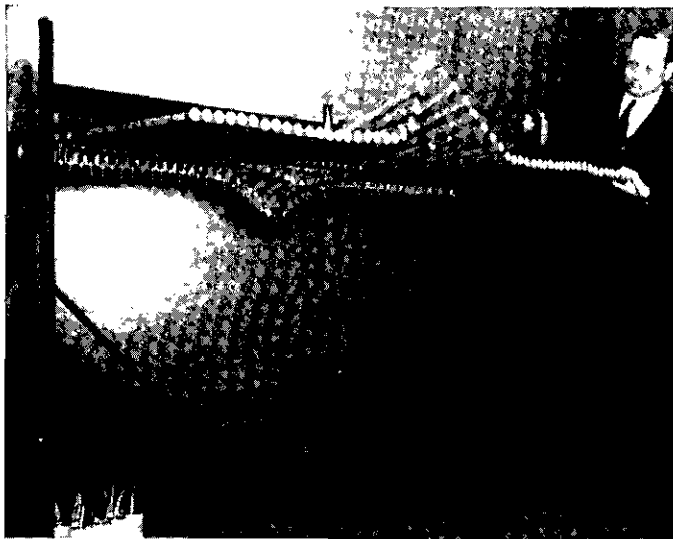

Fig. 2—Photograph of mechanical wave analogy.

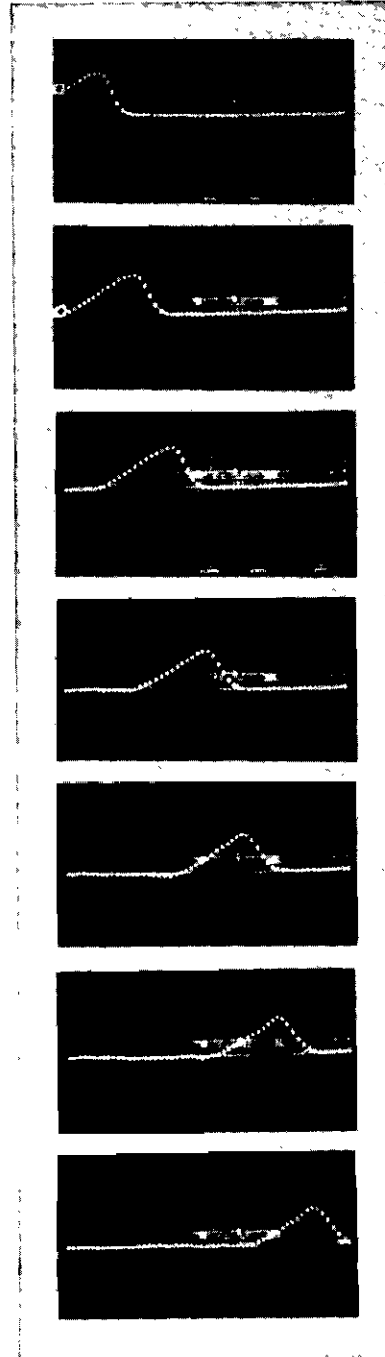

Fig. 3—Illustrating wave form of the traveling wave in a mechanical analogue for successive intervals of time.

ished amplitude. The same phenomenon can be demonstrated by means of a number of analogies. One which is particularly adapted to the present problem has been developed by Wagner¹ and is illustrated in Fig. 2. It consists of a number of aluminum arms mounted side by side. These arms are balanced about their center of rotation and their axes of rotation are in the same straight line. The only connection between adjacent arms is a flat spring, which offers a restraining torque when one arm is displaced with respect to the next. The mass of the arm corresponds to the inductance of the line and the spring to the capacitance. Fig. 3 illustrates what happens in this device when a disturbance is applied at one end. The wave moves along the line with essentially undiminished amplitude and unchanged wave form.

2. Current Wave, Surge Impedance and Surge Admittance

Knowing that the voltage surge moves along the line and imparts charge to the capacitors at any particular point only for the duration of the wave at that location, one can see that currents must flow in the connecting inductances, but only for the interval during which the surge exists at that point. That is, a wave of current should accompany the wave of voltage. It can be shown mathematically that the current wave will have exactly the same wave form as the voltage and at any instant will be proportional to the voltage. The constant of proportionality is known as the surge impedance and is usually designated by the symbol Z . It is equal to $\sqrt{\frac{L}{C}}$ where L is the inductance in henries per unit length of line and C is the capacity in farads per unit length of line. The dimensions of Z are those of a resistance and its value is expressible in ohms. Thus there exists the relation

$$e = iZ = i\sqrt{\frac{L}{C}} \quad (1)$$

where

e = instantaneous voltage
 i = instantaneous current.

The reciprocal of surge impedance is called the surge admittance and is usually designated by the symbol Y . Thus

$$i = Ye \quad (2)$$

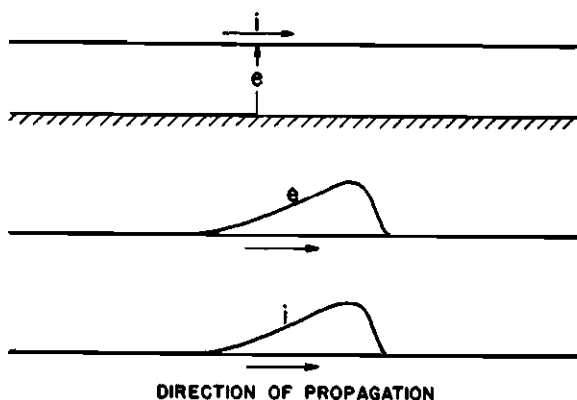

Fig. 4—Depicting a voltage wave and its associated current wave together with the positive sense assumed.

In Fig. 4 is depicted the general properties of traveling waves just enunciated. Note that the positive sense of potential is taken with respect to ground as zero and that the positive sense of current flow in the conductor is the same as the direction of propagation of the wave.

3. Line Constants

The inductance of a single conductor parallel to the earth, assuming an earth of zero resistivity, is

$$L = (2)(10^{-9}) \log_{10} \frac{2h}{r} \text{ in henries per cm.} \quad (3)$$

$$= (7.410)(10^{-4}) \log_{10} \frac{2h}{r} \text{ in henries per mile} \quad (4)$$

and its capacitance

$$C = \frac{10^{-11}}{18 \log_{10} \frac{2h}{r}} \text{ in farads per cm.} \quad (5)$$

$$= \frac{(3.882)(10^{-8})}{\log_{10} \frac{2h}{r}} \text{ in farads per mile.} \quad (6)$$

where h = height of conductor above ground
 r = radius of conductor in same units.

The foregoing expression for inductance assumes that there is no flux within the conductor. This is the case for surges of short duration, because the current flows in a thin layer next to the surface—the phenomenon of “skin effect.” For this reason ferrous conductors can be treated as non-ferrous conductors in considering traveling waves.

Making the same assumptions for cables (that all the current flows next to the return conductor) the inductance is

$$L = (7.410)(10^{-4}) \log_{10} \frac{r_2}{r_1} \text{ in henries per mile.} \quad (7)$$

and the capacitance is

$$C = \frac{(3.882)(10^{-8})k}{\log_{10} \frac{r_2}{r_1}} \text{ in farads per mile.} \quad (8)$$

where

r_1 = radius of conductor
 r_2 = inner radius of sheath
 k = permittivity

4. Evaluation of Surge Impedance

The surge impedance of a single aerial wire with ground return is

$$Z = \sqrt{\frac{L}{C}} = \sqrt{\frac{(7.410)(10^{-4}) \log_{10} \frac{2h}{r}}{(3.882)(10^{-8}) \log_{10} \frac{2h}{r}}} \quad (9)$$

$$= 138 \log_{10} \frac{2h}{r} \text{ ohms}$$

The curve of Fig. 5 will assist in the ready evaluation of this expression. In the absence of more definite information a surge impedance of 500 ohms is usually assumed.

For cables

$$Z = \frac{138}{\sqrt{k}} \log_{10} \frac{r_2}{r_1} \text{ ohms} \quad (10)$$

A good average value for this quantity is 50 ohms.

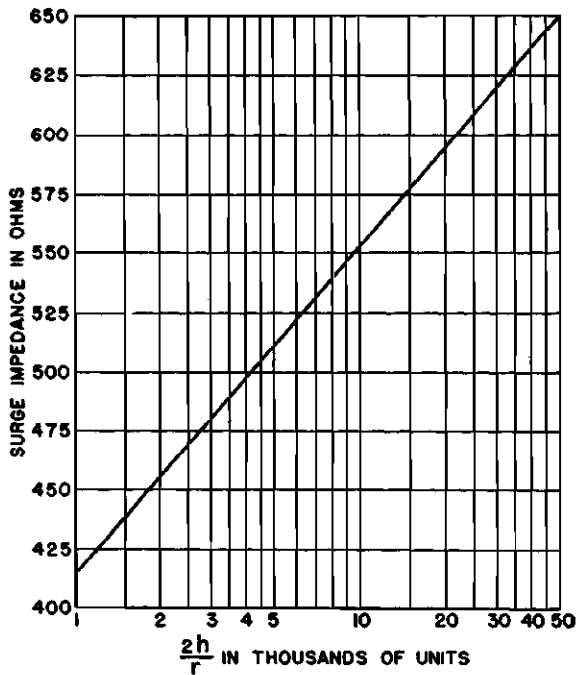

Fig. 5—Surge impedance of an aerial conductor.

5. Velocity of Propagation

The velocity of propagation of any electromagnetic disturbance in air is the same as that of light, namely 2.998×10^{10} cm. per sec. The only difference for transmission lines is that the conductor provides a guide. In terms of the constants of the line, this velocity is equal to $\frac{1}{\sqrt{CL}}$. To verify the velocity relation, substitute (3) and (5) into this expression giving

$$\text{velocity} = \frac{1}{\sqrt{CL}} = \frac{1}{\sqrt{\frac{(10^{-11})(2)(10^{-9}) \log \frac{2h}{r}}{18 \log \frac{2h}{r}}}}$$

$$= 3 \times 10^{10} \text{ cm per sec.}$$

A convenient though approximate figure of 1000 ft per microsecond (a more exact value being 984 ft per microsecond) is generally used in connection with line calculations.

Applying relation (11) to cables there results that

$$\text{velocity} = \frac{1}{\sqrt{CL}} = \frac{(3)(10^{10})}{\sqrt{k}} \text{ cm per sec.} \tag{12}$$

This likewise is a special case of a more general phenomenon, that the velocity of propagation of any disturbance in a medium of permittivity k varies inversely as the square root of the permittivity. Since the permittivity of materials used in cables varies from about 2.5 to 4.0, the velocity of propagation of surges in cables is about one-third to one-half that of light. Similarly a disturbance in a counterpoise buried in earth having a permittivity of say 6 propagates within the earth at a velocity of $\frac{1000}{\sqrt{6}}$ or 408 ft. per microsecond.

6. Mathematical Expression of Voltage and Current Wave

Mathematically a traveling wave can be designated as follows:

$$e = f(x - vt) \tag{13}$$

where x is the distance measured along the line and v is the velocity of propagation. With t fixed, plotting e as a function of x gives the voltage distribution along the line at that instant. With x fixed e gives the variation of the voltage with time at that point.

Similarly, the current wave is

$$i = \frac{e}{Z} = \frac{f(x - vt)}{Z} \tag{14}$$

7. Waves in Reverse Direction

The same relations as mentioned above apply to a wave traveling in the opposite direction when the positive sense of current is taken the same as the direction of propagation. This means that the positive sense of current would be the reverse of the wave moving in the opposite direction. For analytical work it is convenient that the positive sense of both currents be the same. By arbitrarily reversing the sign of one of the currents and making the corresponding

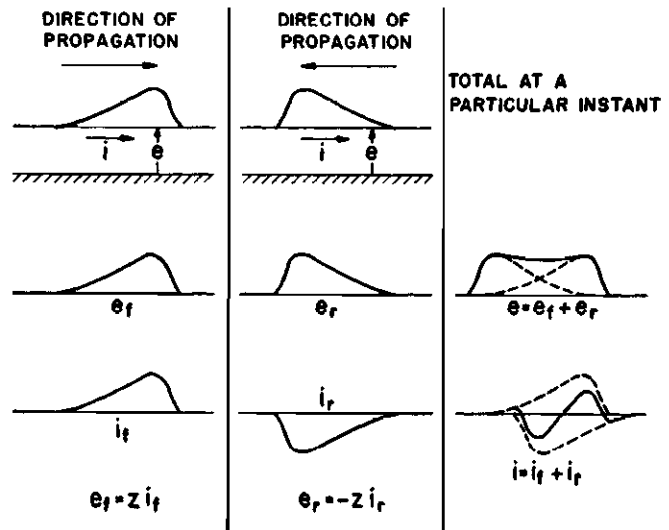

Fig. 6—Forward and backward voltage waves with their associated current waves and also the sum of the two.

changes in the equations, this difficulty may be avoided. Fig. 6 gives the conventions adopted for both types of waves together with the equations relating the voltages and currents. The waves moving from left to right are designated by the subscript f suggestive of forward moving and the wave from right to left by the subscript r suggestive of a wave moving in the reverse direction or a reflected wave.

8. Principle of Superposition

When two waves of this character meet, they do not influence each other but seem to pass through each other. An illustration of this phenomenon is shown in Fig. 7 in which two oppositely moving waves meet in the me-

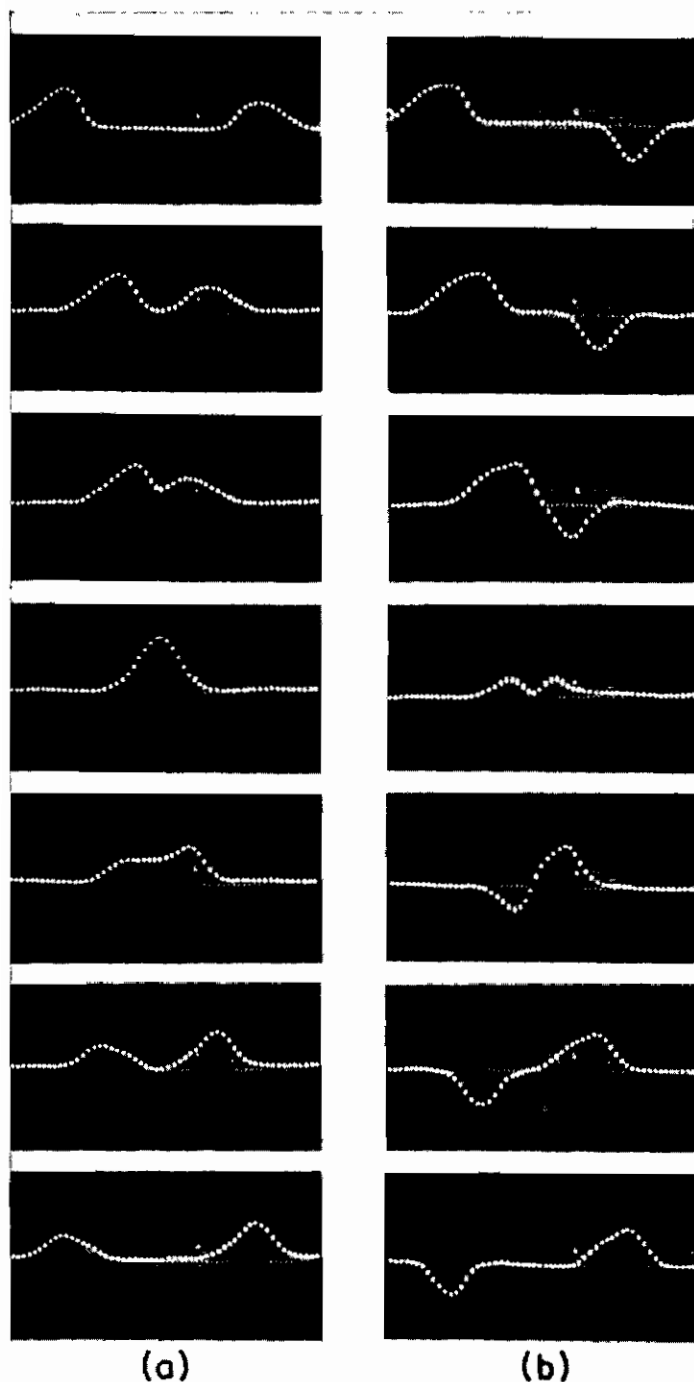

Fig. 7—Illustrating superposition of two waves upon each other.

(a) Two positive waves. (b) One positive and one negative wave.

chanical analogy described previously. Upon meeting, the instantaneous amplitudes of the two waves add together but, after passing through each other, remain undisturbed in magnitude and wave shape. Thus traveling waves may be said to follow the laws of superposition. Each component can be analyzed separately. The right hand column of Fig. 6 shows how the two voltage and current waves add at a particular instant.

II. POINTS OF DISCONTINUITY

When a simple voltage and current wave (e_t and i_t) moves along a line and meets a point of discontinuity reflections take place. If a resistor is connected across the end of a line, the reflections from this point are relatively simple to calculate but if the resistor is replaced by an inductor or capacitor the solution becomes more complicated. Some of the more usual cases will be analyzed in detail.

9. Relations for Simple Reflections from the End of the Line

In Fig. 8 let e_t and i_t be the instantaneous voltage and current of the forward wave at the point of discontinuity. These are usually the known quantities. Further, let e_r and i_r be the instantaneous voltage and current of the reflected wave at the point of discontinuity, and e and i the instantaneous voltage and current at the point of discontinuity. Thus

$$e = e_t + e_r \tag{15}$$

$$i = i_t + i_r \tag{16}$$

$$= \frac{e_t}{Z} - \frac{e_r}{Z} \tag{17}$$

From (17)

$$Zi = e_t - e_r \tag{18}$$

Adding (15) and (18)

$$e + Zi = 2e_t \tag{19}$$

This equation supplies a relation connecting e and i with the instantaneous value of the oncoming wave. The shunting network must supply another equation to provide the solution.

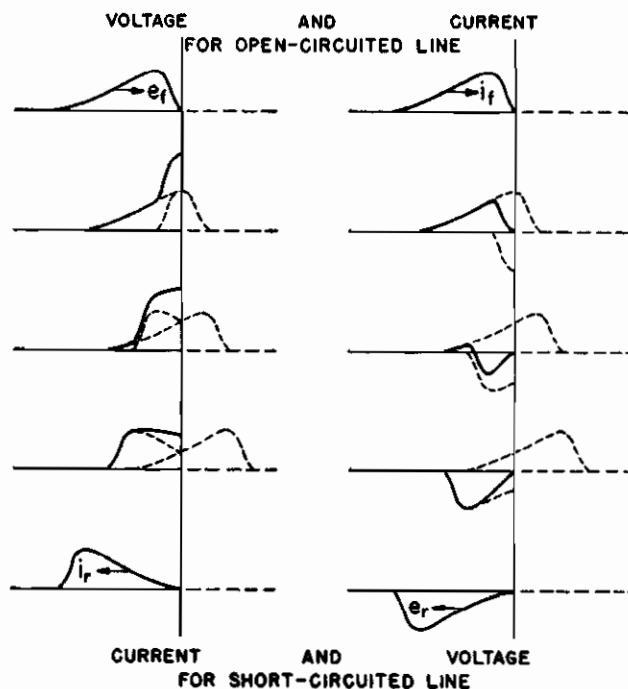

Fig. 8—Reflection of waves from open-circuited and from short-circuited end of line.

After e and i have been determined, e_r can be obtained by subtracting (18) from (15) giving

$$e_r = \frac{1}{2}(e - Zi) \quad (20)$$

An alternate form is obtained by inserting e from (19) into (20), giving

$$e_r = e_t - Zi \quad (20a)$$

10. Line Terminated by a Resistance — Open and Short-Circuited Line

When the line is terminated by a resistance R , then

$$e = Ri \quad (21)$$

Combining this with (19)

$$i = \frac{2}{R+Z}e_t \quad (22)$$

$$e = \frac{2R}{R+Z}e_t \quad (23)$$

And from (20)

$$e_r = \frac{R-Z}{R+Z}e_t \quad (24)$$

(a) **Open-Circuited Line.** If $R = \infty$, the condition which corresponds to an open-circuited line, then

$$e_r = e_t \quad (25)$$

Thus, the reflected wave is equal to the oncoming wave. Also

$$e = 2e_t \quad (26)$$

a relation which proves the well-known doubling up of a voltage wave as it strikes the end of an open-circuited line. Equating e_r and e_t to their Zi equivalents from Fig. 6 there is obtained

$$i_r = -i_t \quad (27)$$

a relation that must be maintained since the currents at the end of an open line must be zero, that is, $i = i_r + i_t = 0$. The variations of the principle quantities at different instants are illustrated in Fig. 8.

(b) **Short-Circuited Line.** For the short-circuited condition R of Eq. (24) is zero, for which

$$e_r = -e_t \quad (28)$$

The reflected wave is the negative of the oncoming wave at any instant and the sum of the waves, e , is equal to zero. On the other hand, inserting the Zi equivalents of e_r and e_t in (28), there results that

$$i_r = i_t \quad (29)$$

which shows that the total current doubles at the end of the line. As shown in Fig. 8, the relations are the same as for the open-circuited line except that the voltages and currents are interchanged.

(c) **$R = Z$.** For this case as can be seen from (24), e_r is equal to zero and there is no reflected wave. Since the line has the same characteristic as that of a resistance it is evident that electrically there is no discontinuity. The wave merely disappears as the end of the line is reached.

(d) **Other Cases.** For other cases the reflected wave will be positive or negative depending upon the extent to which R is greater or less than Z .

11. Junction of Dissimilar Lines

Fig. 9 (a) illustrates the case in which the section to the left of a represents a line whose surge impedance is Z and the section to the right one whose surge impedance is Z' . Since the volt-ampere characteristics of a line are the same as those of a resistance, the reflections resulting when a wave approaches the junction point from the left are the same as though the line to the right of a were replaced by a resistance equal to Z' , as shown in Fig. 9 (b).

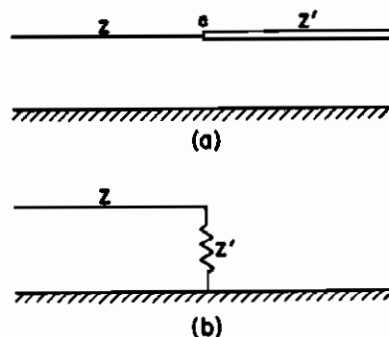

Fig. 9—Equivalent circuit of line terminating at (a) and continued by a line of different surge impedance.

The instantaneous voltage, e , and the reflected wave at the junction point can be computed by Eqs. (23) and (24), respectively. The voltage, e , thus gives the wave shape of the wave propagated out along the line to the right of a .

12. Junction of Several Lines

When a surge travels along line A of Fig. 10 and strikes the junction point of two or more other lines that are separated a sufficient distance that mutual coupling between them is negligible, the reflections and transmitted voltages can be calculated by replacing the lines to the right of the junction points by a shunt resistance as in Fig. 9 in which the resistance is equal to the parallel surge impedance of all the lines to the right of a . Equal voltage waves are then propagated along lines B , C and D .

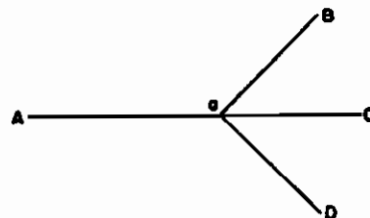

Fig. 10—Junction of several lines.

13. Single Line Terminated by an Inductance

The schematic diagram for this case is shown in Fig. 11. From the terminating network there results that

$$e = L \frac{di}{dt} \quad (30)$$

Combining this with Eq. (19)

$$2e_t = Zi + L \frac{di}{dt} \quad (31)$$

It will be observed that the solution of this equation is the same as the case for which the voltage $2e_t$ is applied to a resistance and inductance circuit in which the resistance

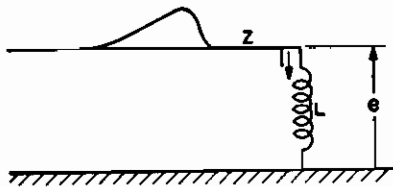

Fig. 11—Line terminated by an inductance.

is Z and the inductance is L . The current depends upon the character of the applied voltage.

If e_t is a square-topped wave of magnitude E , i approaches a magnitude of $\frac{2E}{Z}$ along an exponential curve whose time constant is $\frac{L}{Z}$. The expression for this curve is

$$i = \frac{2E}{Z} \left[1 - e^{-\frac{Z}{L}t} \right] \quad (32)$$

From (30)

$$e = 2E e^{-\frac{Z}{L}t} \quad (33)$$

From (20), the reflected wave is

$$e_r = E \left[-1 + 2e^{-\frac{Z}{L}t} \right] \quad (34)$$

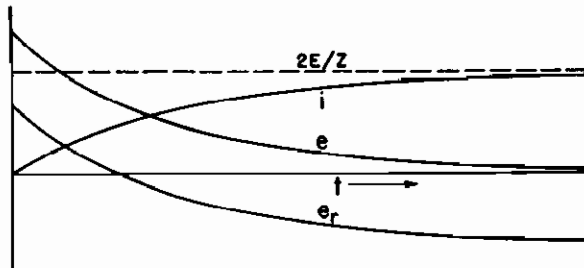

Fig. 12—Voltages and currents at the end of the line shown in Fig. 11 in response to a square-top wave having a maximum value of E .

Fig. 12 shows graphs of these curves and Fig. 13 successive positions of the oncoming and reflected wave. It will be observed that the circuit acts like an open-circuited line initially but finally takes on the characteristics of a short-circuited line. The voltage starts at a value twice that of the oncoming wave and finally reaches zero. The reflected wave starts at $+E$ and gradually approaches $-E$.

If instead of a square-topped wave the oncoming wave e_t of Eq. (31) is of a generalized form, such as shown in Fig. 14, the current response can be determined by the follow-up method described in Part VI, Sec. 20 of Chap. 6. Equation (31) characterizes the phenomenon as one in which the instantaneous value of i tends to approach, along an exponential curve whose time constant is $\frac{L}{Z}$, a value determined by the voltage at that instant divided by the surge impedance. Fig. 14 illustrates the graphical construction.

From (19)

$$e = 2e_t - Zi \quad (35)$$

which permits the determination of e since both e_t and i are now known. The reflected voltage wave can be de-

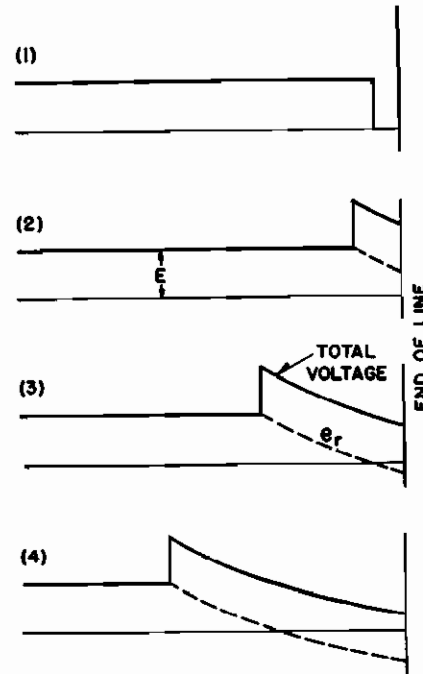

Fig. 13—Reflected wave and total voltage waves at successive instants upon a line terminated by an inductance in response to a square topped wave having a maximum value of E .

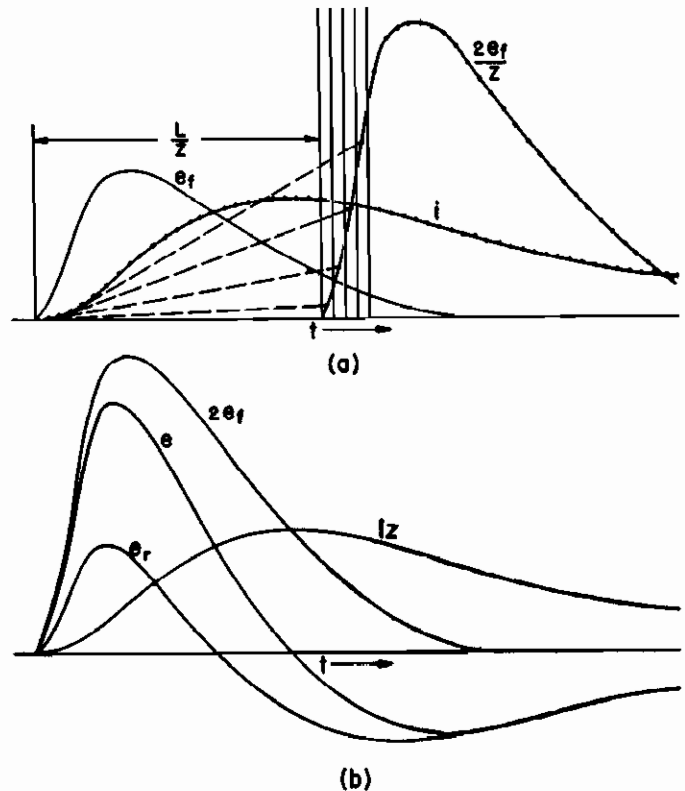

Fig. 14—Graphical method of analyzing line terminated by an inductance.

terminated through the use of Eq. (20a). All of these quantities are shown in Fig. 14. Fig. 15 illustrates the relative positions along the line of these waves at different instants.

14. Single Line Terminated by a Capacitor

Fig. 16 shows the schematic diagram for this case from which it may be seen that

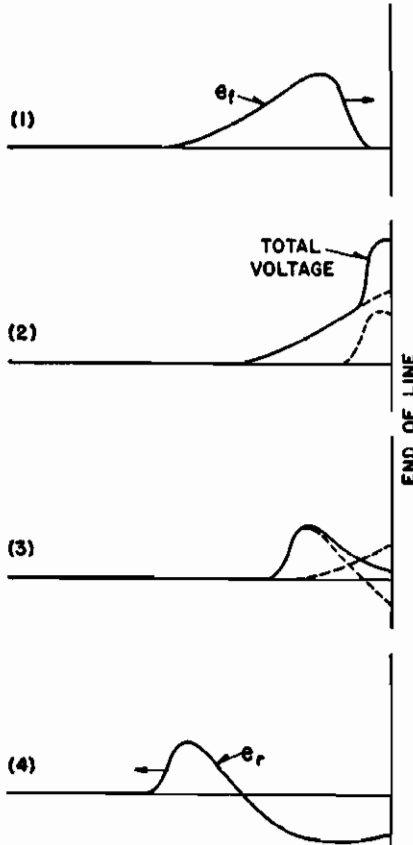

Fig. 15—Relative positions of waves of Fig. 14 along line at different instants.

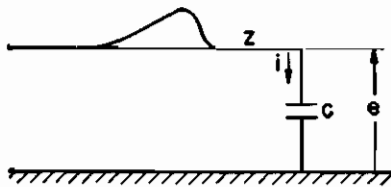

Fig. 16—Line terminated by a capacitor.

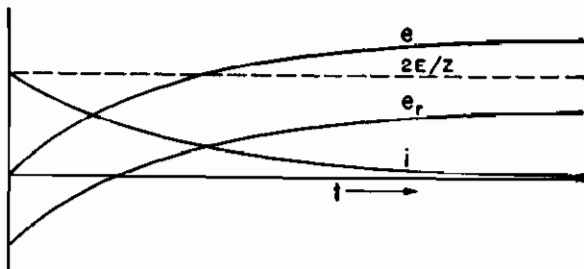

Fig. 17—Voltages and currents at the end of the line shown in Fig. 16 in response to a square-top wave having a maximum value of E .

$$e = \frac{1}{C} \int i dt$$

Substituting this expression for e into (19) there results that

$$2e_t = Zi + \frac{1}{C} \int i dt$$

This is the well known equation representing the charging of a capacitor through a resistance upon the application of a voltage $2e_t$.

If e_t is a square-topped wave of magnitude E , i is equal to

$$i = \frac{2E}{Z} \epsilon^{-\frac{t}{2C}} \tag{36}$$

From (19)

$$e = 2e_t - Zi = 2E \left(1 - \epsilon^{-\frac{t}{2C}} \right) \tag{37}$$

From (20a)

$$e_r = e_t - Zi = E \left[1 - 2\epsilon^{-\frac{t}{2C}} \right] \tag{38}$$

These quantities are plotted as a function of time in

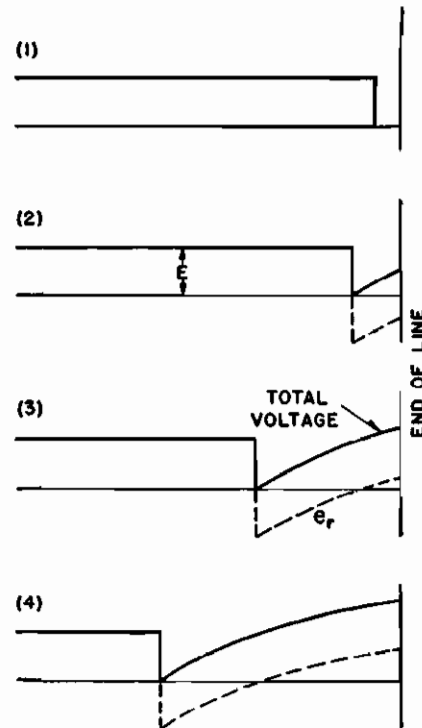

Fig. 18—Reflected and total voltage waves upon a line terminated by a capacitor in response to a square-topped wave having a maximum value (E).

Fig. 17. Fig. 18 shows the position of the reflected wave and the total voltage at different instants of time.

15. Special Case

A special case will be considered for which the voltage across the terminal equipment is a non-linear function of the current through it, such as for a lightning arrester. In Fig. 19 let the heavy full line represent the volt-ampere characteristic of the arrester and the dotted straight line

Zi , the surge impedance of the line times the current through the arrester. From (19)

$$e_t = \frac{1}{2}(e + Zi) \quad (39)$$

This quantity is plotted also in Fig. 19. Since e_t is the magnitude of the oncoming wave at any instant, then i

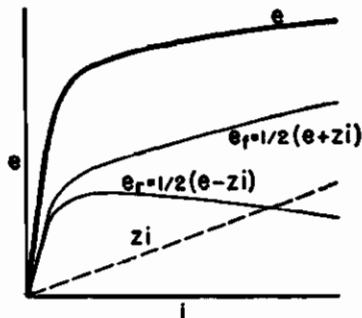

Fig. 19—Special case where voltage across terminal equipment is a known function of current through it.

and, consequently, e is known for any value of e_t and can be plotted as a function of time. Similarly, from (20), e_r can also be plotted against i and is known in terms of e and e_t .

16. Network Connected in Shunt Across a Continuous Line

The schematic diagram for this case is shown in Fig. 20. Let a wave travel from the left and approach the network. As the network is reached a reflection will occur

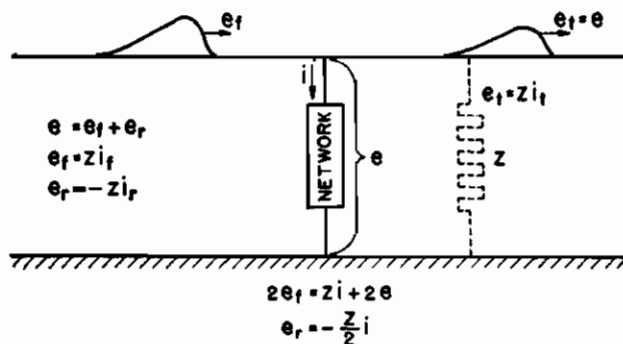

Fig. 20—Network connected in shunt across a continuous line.

and a voltage e is built up across the network. A wave, e_t is transmitted along the line to the right equal at any instant at the junction point to the voltage e . From the voltage conditions at the junction point

$$e_t + e_r = e \quad (40)$$

and from the current relations

$$i_t + i_r = i + i_t$$

or

$$\frac{e_t}{Z} - \frac{e_r}{Z} = i + \frac{e_t}{Z}$$

$$= i + \frac{e}{Z}$$

or

$$e_t - e_r = Zi + e \quad (41)$$

Adding (40) and (41)

$$2e_t = Zi + 2e \quad (42)$$

The shunting network will provide another equation connecting e and i which in combination with Eq. (42) permits of the determination of e and i . Subtracting (40) and (41)

$$e_r = -\frac{Z}{2}i \quad (43)$$

Note that the line to the right can be replaced by a resistor Z in shunt across the network at the junction point as shown by the dotted line.

As an illustration of this case let the network be a resistor R . Then

$$e = Ri$$

and substituting in (42)

$$2e_t = Zi + 2Ri$$

or

$$i = \frac{2}{Z + 2R}e_t \quad (44)$$

and

$$e = \frac{2R}{Z + 2R}e_t \quad (45)$$

The transmitted wave is also equal to (45) and the reflected wave is from (43)

$$e_r = -\frac{Z}{Z + 2R}e_t \quad (46)$$

III. LATTICE NETWORKS

When the circuit consists of a number of shunt impedances distributed along the line as in Fig. 21 (a), the solution is expedited and simplified by means of the lattice network by Bewley. While the system can be applied generally, it will be discussed principally with regard to shunt resistors.

17. Voltage Lattice Network

If in Fig. 21(a) a traveling wave e_t moves from the left to right toward a then upon reaching a , a transmitted wave and a reflected wave is produced. These waves can be expressed as follows

$$e_t = \text{transmitted wave} = \alpha_a e_t \quad (47)$$

$$e_r = \text{reflected wave} = \beta_a e_t \quad (48)$$

where α_a is the transmission coefficient which from (45) is equal to

$$\frac{2R_a}{Z + 2R_a} \quad (49)$$

and β_a is the reflection coefficient which from (46) is equal to

$$-\frac{Z}{Z + 2R_a} \quad (50)$$

So long as the line surge impedances are equal on both sides of the resistor then the transmitted and reflected waves are independent of the direction from which the wave propagates. If on the other hand the line is unsymmetrical with respect to the resistor this statement is untrue. Thus, if the line surge impedance to the left of the resistor is Z and to the right Z' , then for a wave mov-

ing from the left hand side at the point *a* the transmission coefficient is

$$\alpha_a = \frac{2RZ'}{RZ + RZ' + ZZ'} \quad (51a)$$

and the reflection coefficient is

$$\beta_a = \frac{RZ' - RZ - ZZ'}{RZ + RZ' + ZZ'} \quad (51b)$$

For a wave moving from the right to the left the transmission coefficient, γ_a , is

$$\gamma_a = \frac{2RZ}{RZ' + RZ + ZZ'} \quad (51c)$$

and the reflection coefficient, δ_a , is

$$\delta_a = \frac{RZ - RZ' - Z'Z}{RZ' + RZ + Z'Z} \quad (51d)$$

When the transmitted wave from *a* reaches *b*, another reflection and partial transmission occurs. The reflected wave from *b* is partially transmitted and reflected from *a*. This continues indefinitely throughout the network until the components have been reduced to zero. By means of the system² shown in Fig. 21 (b) account can be kept of each component not only in magnitude but in time. The horizontal distance represents length along the line and the vertical distance time. The inclined lines are so sloped that the vertical distance represents the time required for the original wave or a reflected component to reach the point designated. Let zero time be the instant at which the traveling wave e_t leaves 0. At time t_1 this wave has reached *a*. The reflected wave from this point is $\beta_a e_t$ which is sloped the opposite direction and is thus indicative of motion in the reverse direction. The transmitted wave from *a*, $\alpha_a e_t$ reaches *b* at time t_2 when a reflection $\beta_b \alpha_a e_t$ occurs and the wave $\alpha_b \alpha_a e_t$ is transmitted beyond this point. This latter wave reaches *c* at the time t_3 . Each wave whether it be transmitted or reflected has its own transmitted and reflected components. Where two waves coincide as at *b* for time t_5 where waves from *a* and *c* arrive at the same time, the reflected and transmitted waves from this point are added, as has been done for the wave between *b* and *a* between t_5 and t_6 .

To determine the actual voltage at any point such as *X* it is necessary to add the different components with their proper time relations as is shown in Fig. 21(c). The method is much simpler than this description might convey as numerical values simplify very greatly the appearance of the steps. In most cases the resistors are equal and equally spaced. If the voltage at any of the resistors is desired, the components of voltage on either *one* side or the *other* should be added *not* the components on *both* sides.

18. Current Lattice Network

So far consideration has been given only to the voltage waves in lattice networks. The currents can be obtained from the voltage components by merely dividing those that move from left to right by the proper line surge impedance *Z* and those that move from right to left by the corresponding $-Z$. The sign is determined simply by the direction of downward slope of the lines in Fig. 21(b). However, instead of using the voltage waves as a basis for the lattice network, the current waves can be used with equal facility. A similar set of equations employing transmission and reflection coefficients relates the transmitted and reflected waves to the oncoming wave approaching the discontinuity.

For waves, I_t , moving from left to right

$$i_t = \text{transmitted current wave} = \alpha_a i_t \quad (52)$$

$$i_r = \text{reflected current wave} = -\beta_a i_t \quad (53)$$

For waves, I_t , moving from right to left

$$i_t = \gamma_a i_t \quad (54)$$

$$i_r = -\delta_a i_t \quad (55)$$

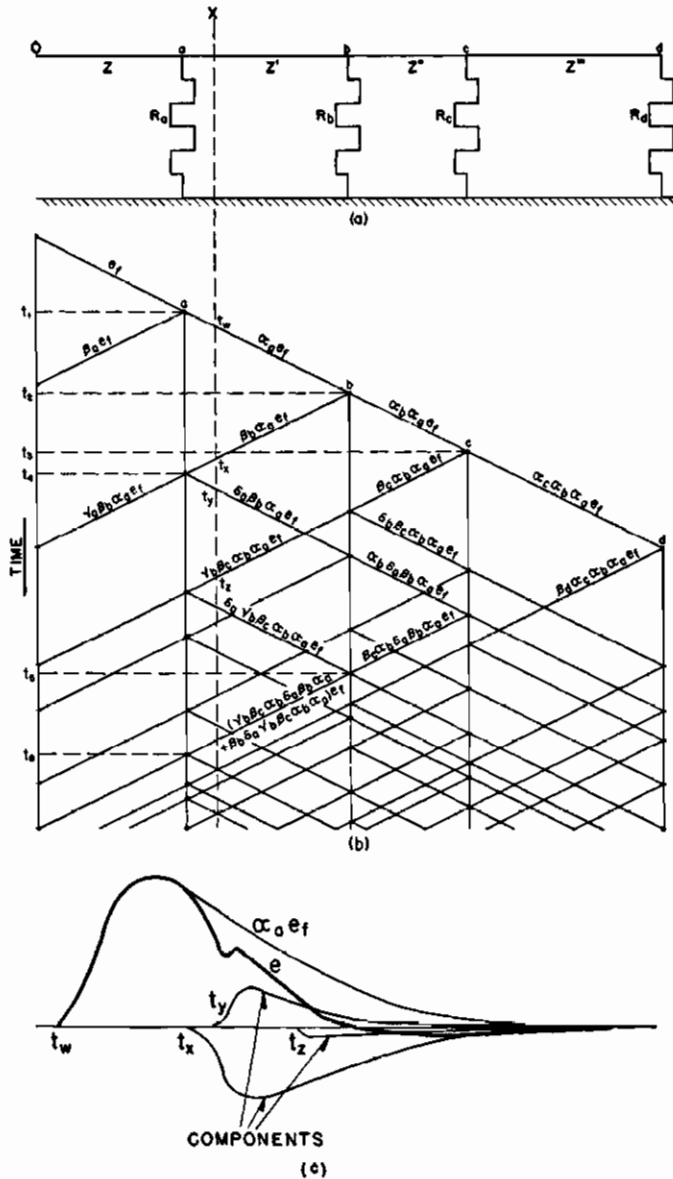

Fig. 21—Lattice network.

(a) Equivalent circuit of line with several shunt impedances at distributed points. (b) Lattice network for voltages on above circuit. (c) Addition of components from lattice network to give actual voltage at a given point.

For these equations the transmission and reflection coefficients are identical to those used for the voltages in the voltage lattice network for either the simple condition of uniform line surge impedance Z (see equations 49 and 50) or for the more general case of different surge impedances on each side of the point of discontinuity (see equations 51(a) to 51(d)). The negative signs in equations (53) and (55) for the reflected waves are due to difference in polarity relations between the current waves and their corresponding voltage waves for surges propagating in the two directions.

In accordance with Kirchoff's law, the current flowing in any of the shunt resistors is equal to the algebraic sum of the current waves moving into and out of the point. Where the line surge impedance Z is the same on both sides of the resistor, the resistor current can be given in terms only of the summation of the incoming waves from both left and right by the following equation

$$i_{(\text{resistor})} = \frac{2R}{Z+2R} \sum i_t \quad 56(a)$$

In summing the different components they must be added with the proper time displacement between them.

IV. MUTUALLY COUPLED CIRCUITS

19. Voltages and Currents for Two Parallel Conductors

Just as the steady-state voltage and current relations between two coupled electromagnetically or two electrostatically coupled circuits can be expressed in terms of two simple linear equations so also can the relations between voltages and currents associated with traveling waves in two parallel conductors be similarly expressed.

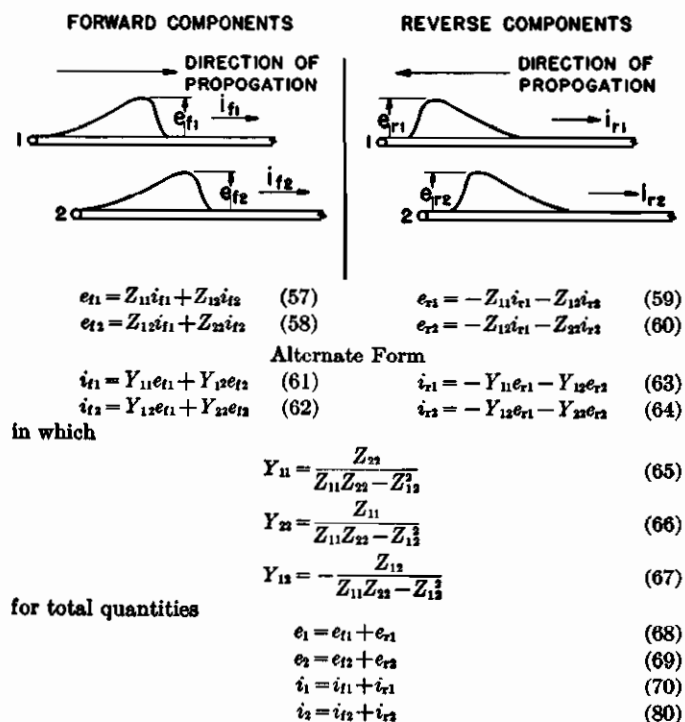

These relations for a pair of forward moving waves is given by Eqs. (57) and (58) of Fig. 22. The voltages are measured with respect to ground as zero potential and the positive sense of current flow is taken as from left to right. The corresponding relations for a reverse moving pair is given by Eqs. (59) and (60). The coefficients in these equations are called self and mutual surge impedances.

The converse relations for currents in terms of voltages are given by equations (61) to (64) in which the coefficients are called the self and mutual surge admittances. Equations (65) to (67) give the admittances in terms of the surge impedances.

For cases in which these components only are involved the total voltages and currents in the two conductors are given by Eqs. (68) to (80).

Where more than two conductors are involved these equations may be generalized quite readily by the addition of other terms. Thus, for three conductors Eqs. (57) and (58) would be extended by the addition of a third term involving the current in the third conductor with a coefficient equal to the mutual surge impedance. In addition a third equation would be introduced for e_{f3} . Similar additions would be incorporated throughout the system of equations.

20. Self and Mutual Surge Impedances

For most traveling waves the current flows near the surface of the conductor which permits neglecting the flux inside. In addition the earth can in nearly all cases be regarded as having perfect conductivity. For these assumptions the self and mutual impedances in terms of the nomenclature illustrated in Fig. 23 are

$$Z_{11} = 138 \log_{10} \frac{2h_1}{r_1} \text{ ohms} \quad (81)$$

$$Z_{12} = Z_{21} = 138 \log_{10} \frac{b}{a} \text{ ohms} \quad (82)$$

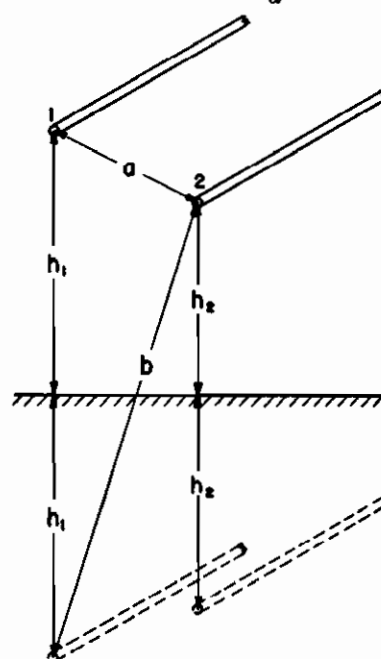

Fig. 23—Two parallel conductors with their images.

Fig. 22—Analytic representation of voltage and current waves on mutually-coupled circuits.

21. Several Conductors in Parallel

There are certain practical cases where surges are introduced simultaneously on several conductors in parallel and sufficient symmetry exists that it can be assumed that the voltage and currents are equal on each of them. For these assumptions an equivalent surge impedance can be determined which enables the treatment of the conductors as a single equivalent conductor.

For two conductors if the voltage, e , of the single equivalent conductor is taken as the mean of e_1 and e_2 and by assumption i_1 and i_2 are equal to $\frac{i}{2}$ where i is the total current, then from equations (57) and (58)

$$e = \frac{e_1 + e_2}{2} = \frac{1}{2}(Z_{11} + 2Z_{12} + Z_{22})i$$

Therefore, the equivalent surge impedance is

$$Z_{eq} = \frac{1}{2}(Z_{11} + 2Z_{12} + Z_{22}) \tag{83}$$

Upon substituting (81) and (82) this becomes

$$Z_{eq} = 138 \log_{10} \sqrt{\frac{2h_1 \left(\frac{b}{a}\right)^2 2h_2}{r_1 r_2}} = 138 \log_{10} \frac{\sqrt{(2h_1)b^2(2h_2)}}{\sqrt{r_1 r_2 a^2}} \tag{84}$$

from which it can be seen that the two conductors can be replaced by a single conductor whose radius is $\sqrt{r_1 r_2 a^2}$ and height above ground is $\frac{1}{2}\sqrt{4h_1 h_2 b^2}$. For most cases the height can be taken as the arithmetic mean of the two conductors and when they have equal radii

$$Z_{eq} = 138 \log_{10} \frac{(h_1 + h_2)}{\sqrt{ar}} \tag{85}$$

22. Wave on One Conductor with the Other Grounded

In order to clarify some of the physical concepts involved several specific cases will be considered. The first of these is shown in Fig. 24, in which a voltage wave is

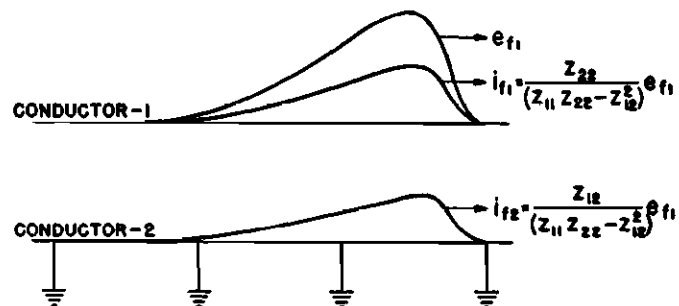

Fig. 24—Voltage and current relations for voltage applied to one conductor with other conductor grounded.

applied to conductor number 1 and conductor number 2 is grounded. Substituting the condition into Eq. (58) that e_{12} is always zero, then

$$i_{12} = -\frac{Z_{12}}{Z_{22}} i_{11} \tag{86}$$

Substituting this value into (57)

$$e_{11} = Z_{11} i_{11} - \frac{Z_{12}}{Z_{22}} i_{11} = \frac{Z_{11} Z_{22} - Z_{12}^2}{Z_{22}} i_{11} \tag{87}$$

It can be seen that the only effect of the presence of the grounded conductor is to reduce the effective surge impedance of the ungrounded conductor.

23. Reflected and Transmitted Waves When One Conductor Is of Finite Length and Open Circuited

This case is illustrated in Fig. 25. Let it be assumed that the forward moving waves e_{f1} and e_{f2} are known and it is desired to determine their associated currents, the voltages

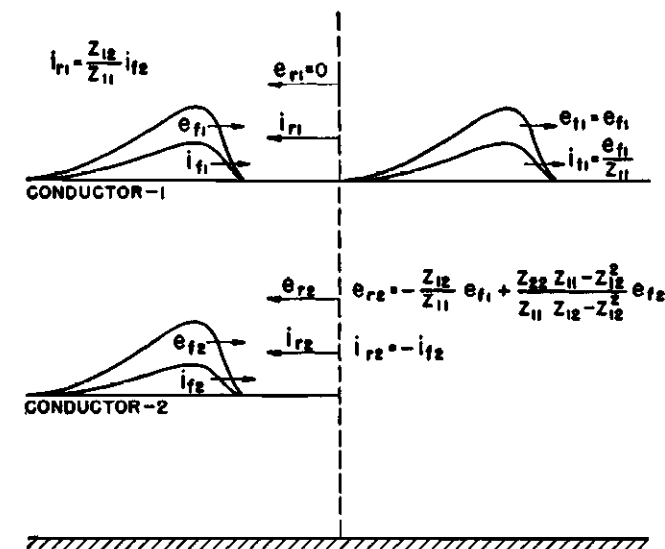

Fig. 25—Reflected and transmitted waves when one conductor is of finite length and open circuited.

and currents that will be reflected backward when the point corresponding to the end of the one line is reached, and the voltage and current transmitted beyond this point on conductor number 1. These quantities constitute the eight unknowns i_{11} , i_{12} , e_{r1} , e_{r2} , i_{r1} , i_{r2} , e_{t1} and i_{t1} . The eight equations required for their solutions are Eqs. (57) to (60) of Fig. 22 and the four following which apply at the point of discontinuity:

$$e_{11} + e_{r1} = e_{t1} \tag{88}$$

$$e_{t1} = Z_{11} i_{t1} \tag{89}$$

$$i_{f1} + i_{r1} = i_{t1} \tag{90}$$

$$i_{f2} + i_{r2} = 0 \tag{91}$$

i_{11} and i_{12} can be determined from Eqs. (57) and (58) and then from Eq. (91) i_{r2} is known. By the combination of Eqs. (88), (89), and (90)

$$e_{11} + e_{r1} = Z_{11}(i_{11} + i_{r1})$$

Substituting in this equation the values of e_{11} and e_{r1} as given by Eqs. (57) and (59) there results

$$Z_{12} i_{f2} - 2Z_{11} i_{r1} - Z_{12} i_{r2} = 0$$

which gives the equation for i_{r1} when the value of i_{r2} given by Eq. (91) is substituted

$$i_{r1} = \frac{Z_{12}}{Z_{11}} i_{f2} \tag{92}$$

Substituting the values of i_{r1} and i_{r2} given by Eqs. (91) and (92) into Eq. (59)

$$e_{r1} = -Z_{11} \left(\frac{Z_{12}}{Z_{11}} \right) i_{t2} - Z_{12} (-i_{t2})$$

$$e_{r1} = 0 \tag{93}$$

Thus there is no reflected voltage wave on conductor number 1 and the voltage e_{t1} is transmitted undistorted past the point of discontinuity.

Making similar substitutions in Eq. (60)

$$e_{r2} = -Z_{12} \left(\frac{Z_{12}}{Z_{11}} i_{t2} \right) - Z_{22} (-i_{t2})$$

$$e_{r2} = \frac{Z_{22}Z_{11} - Z_{12}^2}{Z_{11}} i_{t2} \tag{94}$$

From Eqs. (62), (66), and (67)

$$i_{t2} = -\frac{Z_{12}}{Z_{11}Z_{22} - Z_{12}^2} e_{t1} + \frac{Z_{11}}{Z_{11}Z_{22} - Z_{12}^2} e_{t2}$$

and substituting this value of i_{t2} into Eq. (94)

$$e_{r2} = -\frac{Z_{12}}{Z_{11}} e_{t1} + e_{t2} \tag{95}$$

The total voltage at the end of conductor number 2 is

$$e_2 = e_{t2} + e_{r2} = -\frac{Z_{12}}{Z_{11}} e_{t1} + 2e_{t2} \tag{96}$$

24. Reflected and Transmitted Waves When Conductor of Finite Length Is Grounded

For this case, which is illustrated in Fig. 26, the four additional equations to be used with Eqs. (57) to (60) are the following:

$$e_{t1} + e_{r1} = e_{t1} \tag{97}$$

$$e_{t1} = Z_{11} i_{t1} \tag{98}$$

$$i_{t1} + i_{r1} = i_{t1} \tag{99}$$

$$e_{t2} + e_{r2} = 0, \quad e_{r2} = -e_{t2} \tag{100}$$

These eight equations can be solved for the eight unknowns with the results given in Fig. 26. The relations

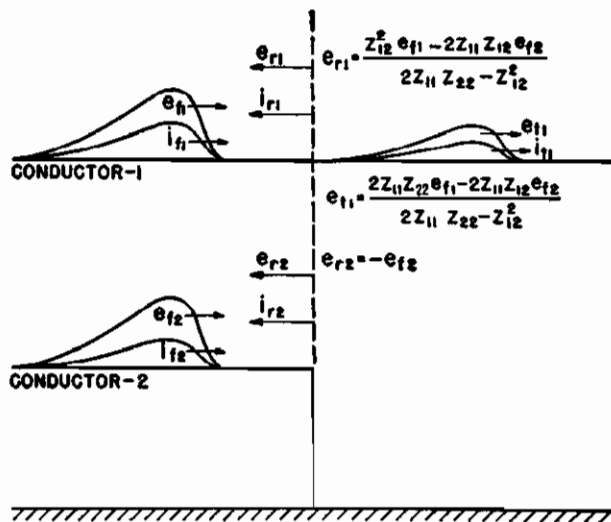

Fig. 26—Reflected and transmitted waves when conductor of finite length is grounded.

for the currents can be determined from the voltages by the equations given in Fig. 22.

25. Conditions at the Beginning of a Parallel

This case is illustrated in Fig. 27, and the point of discontinuity A will be discussed first. As in all the cases just considered, the original waves are regarded as ap-

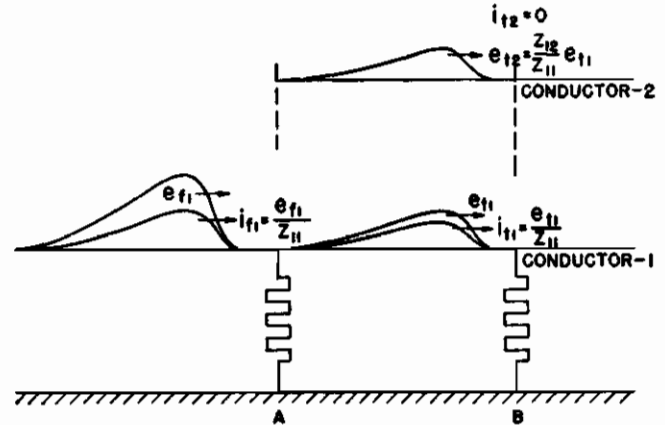

Fig. 27—Conditions at the beginning of a parallel.

proaching the point of discontinuity from the left-hand side. The reverse or backward moving waves of current and voltage to the right of A must therefore be equal to zero. Since no current can flow to the left of A , then the transmitted current wave in conductor number 2 must at all times be equal to zero. The only current present to the right of A is the transmitted current wave in conductor number 1. The presence of conductor number 2 cannot affect either the current or voltage in conductor number 1. Similarly, when considering the discontinuity at B , it follows that since the approaching current wave in conductor number 2 is zero then following the same reasoning as for A , the current in the conductor to the right of B must be zero and conductor number 2 can have no effect upon conductor number 1.

The transmitted and reflected waves in conductor number 1 can be calculated by neglecting the presence of conductor number 2.

26. Coupling Factor

In any case such as Fig. 27 in which the current in one conductor, such as number 2, is zero, the voltages are from Eqs. (57) and (58)

$$e_{t1} = Z_{11} i_{t1}$$

$$e_{t2} = Z_{12} i_{t1}$$

and

$$e_{t2} = \frac{Z_{12}}{Z_{11}} e_{t1} \tag{101}$$

Thus for this condition the voltage induced on conductor number 2 is related to that on conductor number 1 by the term $\frac{Z_{12}}{Z_{11}}$. This is commonly called the coupling factor and will be denoted by the symbol

$$K_{12} = \frac{Z_{12}}{Z_{11}} \tag{102}$$

The coupling factor can be written in terms of the physical constants of the conductors shown in Fig. 23, by the use of Eqs. (81) and (82)

$$K_{12} = \frac{\log \frac{b}{a}}{\log \frac{2h_1}{r_1}} \quad (103)$$

As will be shown subsequently, the coupling factor is of importance in calculating the voltages induced in conductors parallel to those struck directly by lightning. Values of the coupling factor between phase wire and ground wire for lines with one ground wire are given in the curves of Fig. 28 for a practical range of transmission line construction. For estimating purposes a value of 0.25 can be used. In Fig. 28 the coupling factor is plotted as a function of the spacing (a) between the ground wire and conductor for various ground wire heights (h). As shown by Eq. (103) it is also a function of the dimension (b) of Fig. 23 which is defined not only by (h) and (a) but by the angular position of the conductor relative to the ground wire and the vertical. However this angular position has little effect and the curves of Fig. 28 give the coupling factor to within about three percent for practical conductor positions. In addition the curves apply to a fixed ground wire diameter of 1/2 inch. The practical range of ground wire sizes is from 3/8 to 5/8 inches and for this range the use of 1/2 inch gives a maximum error of only five percent.

Coupling Factor Between Conductor and Two Ground Wires. If lightning strikes one conductor of a double ground wire system at midspan without flash-over, coupling factors between the ground wire system and phase conductors can be computed on the basis of involvement of one ground wire only as no current will flow in the other ground wire. This condition applies until the disturbance on the ground wire propagates to a point in the system such as a tower at which metallic connection is made between the two ground wires. If on the other hand the lightning strikes a tower top, then

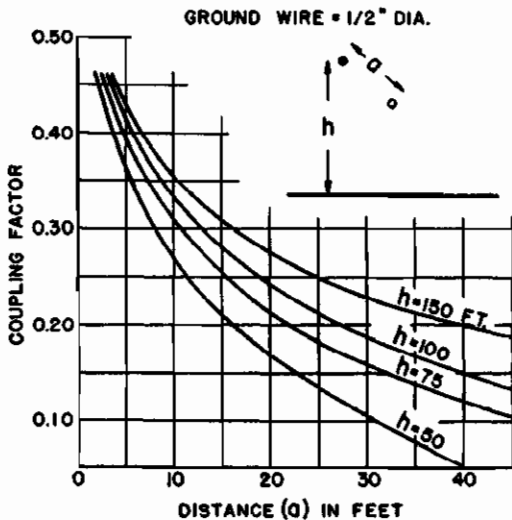

Fig. 28—Coupling factors between conductor and one ground wire 1/2 inch in diameter.

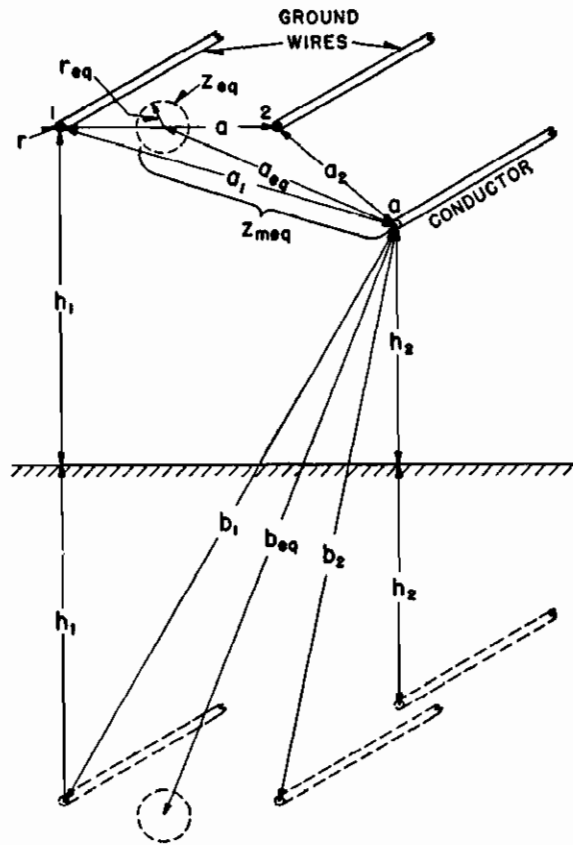

Fig. 29—Configuration for two ground wires and a conductor.

both ground wires are immediately involved. For cases in which both ground wires are involved the voltages and currents because of the usual symmetrical arrangement will be equal on the two ground wires. In Fig. 29 let the quantities referring to the ground wires be designated by the subscripts 1 and 2 and those on the conductor by the subscript a. The voltage induced on the conductor is given by

$$e_a = Z_{1a}i_1 + Z_{2a}i_2 = \frac{(Z_{1a} + Z_{2a})}{2}i$$

where

$$i_1 = i_2 = \frac{i}{2}$$

therefore, the equivalent mutual impedance is

$$Z_{meq} = \frac{Z_{1a} + Z_{2a}}{2}$$

which from Eqs. (81) and (82) is

$$Z_{meq} = 138 \log_{10} \frac{\sqrt{b_1 b_2}}{\sqrt{a_1 a_2}} \quad (104)$$

The two ground wires can be replaced by a single equivalent ground wire whose spacings are shown in Fig. 29. The coupling factor can then be written, by combining Eqs. (85) and (104), as

$$K = \frac{\log \frac{\sqrt{b_1 b_2}}{\sqrt{a_1 a_2}}}{\log \frac{2h_1}{\sqrt{ar}}} = \frac{\log \frac{b_{eq}}{a_{eq}}}{\log \frac{2h_1}{r_{eq}}} \quad (105)$$

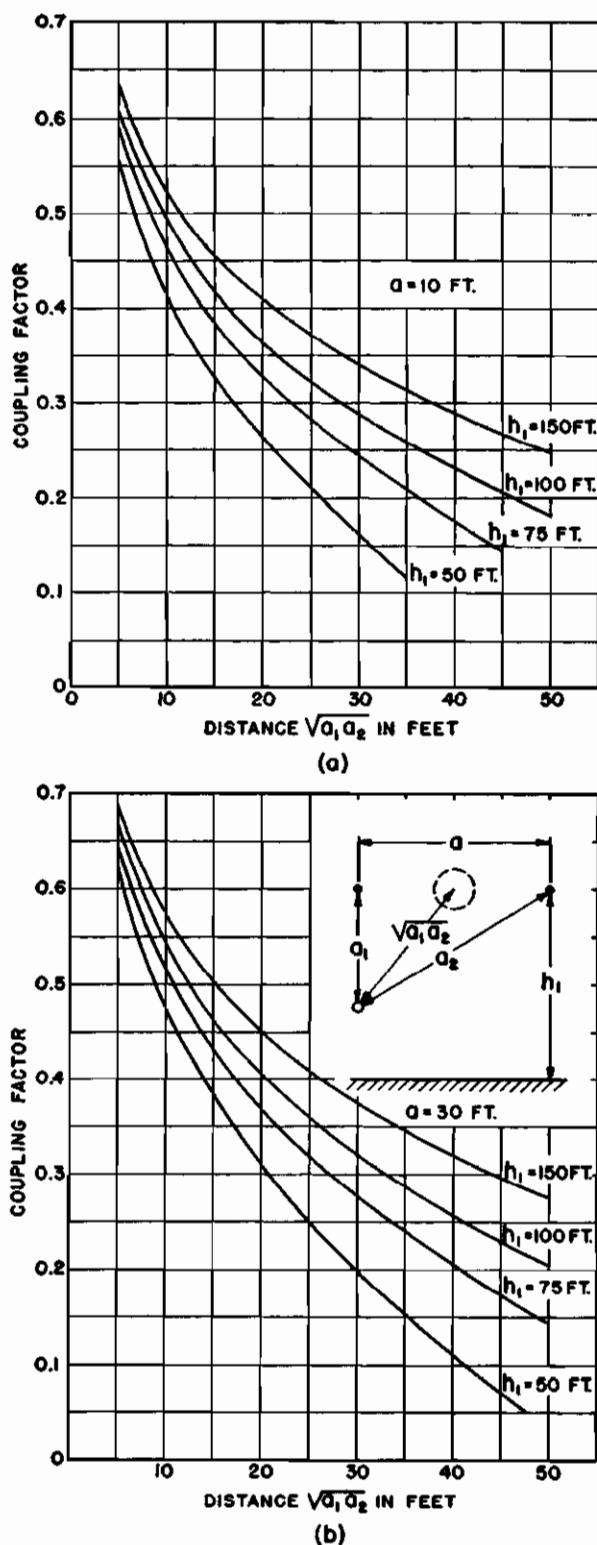

Fig. 30—Coupling factors for two ground wires of $\frac{1}{2}$ -inch diameter.

Fig. 30 gives values of this factor for practical ranges of ground wire and conductor configurations for ground wires of $\frac{1}{2}$ inch diameter. Calculations indicate that for practical configurations these curves are accurate to within about five percent regardless of the position of the con-

ductor with respect to the ground wires. Ground wire diameter has little effect upon coupling factor for values between $\frac{1}{8}$ and $\frac{3}{8}$ inches.

V. ATTENUATION AND DISTORTION

Aside from the effects of reflections at transition points, traveling waves are both attenuated and distorted as they propagate along a line. This is caused primarily by losses in the energy of the wave due to resistance, leakage, dielectric and corona loss. For sufficiently high voltages corona is the most important factor and due to it waves are attenuated within a few miles to a safe voltage.

The nature of the distortion produced is shown in the oscillograms of Fig. 31 which are typical of the results obtained by several studies made with artificial surges on transmission lines⁸⁻¹⁰. Examination of these oscillograms shows that both the front and tail of the wave are sloped off by propagation.

Any of the possible types of losses will produce this effect. Above corona voltage, however, effects become much more pronounced.

27. Effect of Series Resistance

For the special case of the so-called "distortionless line"

$$\frac{R}{L} - \frac{G}{C} = 0 \quad (106)$$

where R is the series resistance and G the shunt conductance per unit length of line. For such a line, surges are attenuated without distortion. The attenuation in a distance x is equal to $e^{-\frac{R}{2}x}$, which expresses the fraction to which the wave is reduced. The unit of x is dependent solely upon the unit used in expressing R .

In actual transmission lines the shunt conductance is so low as to be negligible and the condition expressed by Eq. (106) is not satisfied. Thus in actual lines a surge is not only attenuated but also distorted. If, however, the distortion is neglected and the attenuation is derived on the basis of energy loss alone¹², a factor equal to $e^{-\frac{R}{2Z}x}$ is obtained. Assuming a 0000 copper conductor of surge impedance 500 ohms and d-c resistance of 0.302 ohms per mile, the surge must travel 2300 miles to attenuate to one-half value. Of course, the resistance of the conductor under surge conditions, due to crowding of the current toward the surface, is much greater than that of the d-c value. To form some idea as to the order of magnitude of this effect, the resistance of the conductor at a frequency of 1 000 000 cycles can be calculated. At this frequency the resistance is 18 times the d-c value and assuming a resistance to surges of this magnitude it is found that the surge must travel 130 miles to attenuate to one-half value. In general it may be concluded that the attenuation due to resistance is negligible as compared to other factors, such as corona.

A more accurate indication of the resistance of a conductor under surge conditions is provided by Miller.¹³ If a square-front wave is applied to a conductor, all of the current initially crowds toward the periphery. The current density then "soaks" into the interior with a diffusion

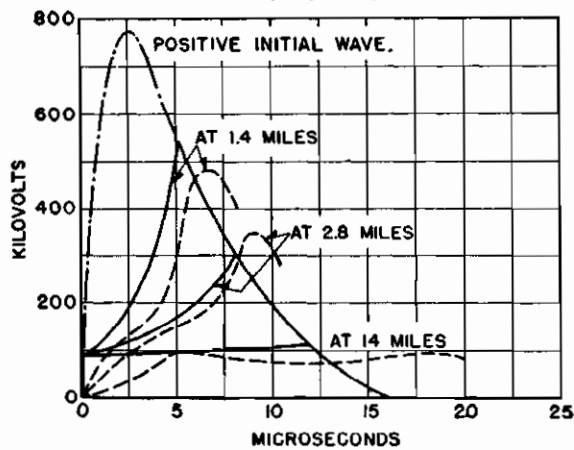
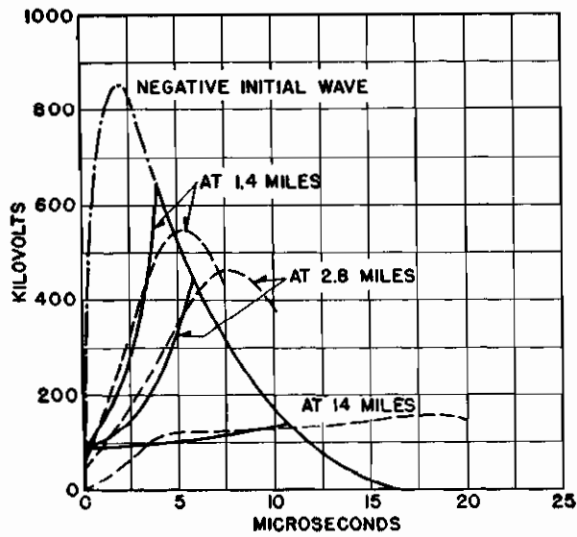

(a)

DOTTED CURVES OSCILLOGRAMS BY BRUNE & EATON⁽¹⁹⁾
 SOLID CURVES CALCULATED BY SKILLING & DYKES⁽²¹⁾

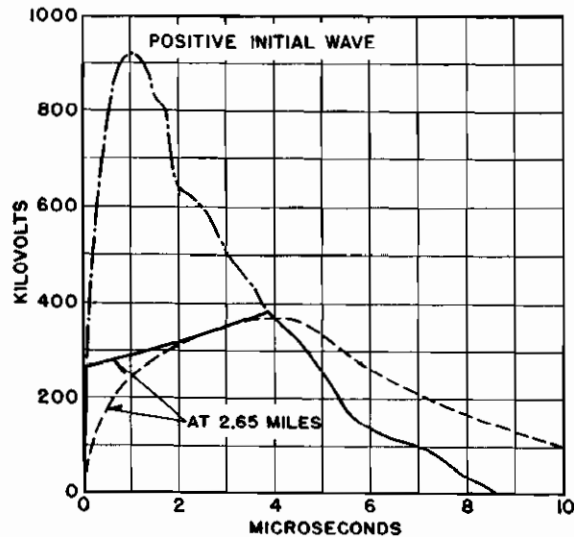

(b)

DOTTED CURVE OSCILLOGRAM BY CONWELL & FORTESCUE⁽¹⁸⁾
 SOLID CURVE CALCULATED BY SKILLING & DYKES⁽²¹⁾

Fig. 31—Oscillograms of artificial surges showing attenuation and distortion.

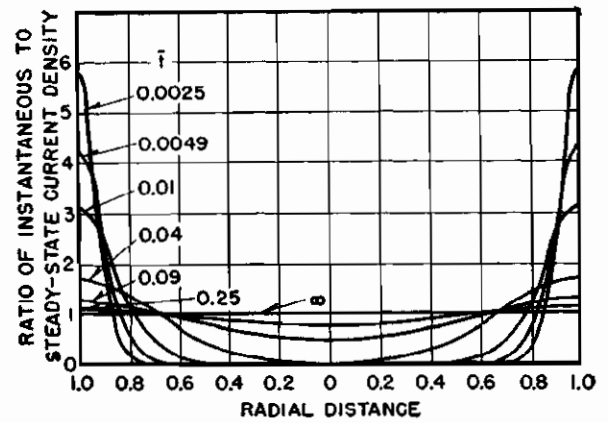

Fig. 32—Transient current distribution in solid rod.

“velocity,” h , given by

$$h = \sqrt{\frac{\rho}{4\pi\mu}} \text{ in cm. per sec.}^{1/2} \quad (107)$$

where

ρ = Specific resistivity.
 μ = Magnetic permeability.

For copper h is 11.6 cm per sec.^{1/2}; for aluminum 14.5; and for steel, if μ is assumed to be 1000, h is 1.9 cm per sec.^{1/2}.

For a solid round conductor, it is convenient to express the results in terms of a numeric given by the relation

$$\bar{t} = \left(\frac{h}{b}\right)^2 t \quad (108)$$

where t is time in seconds and b is the radius of the conductor in cm.

The current distribution within the conductor is shown in Fig. 32. With increasing time the current first crowds toward the periphery at zero time and then penetrates the

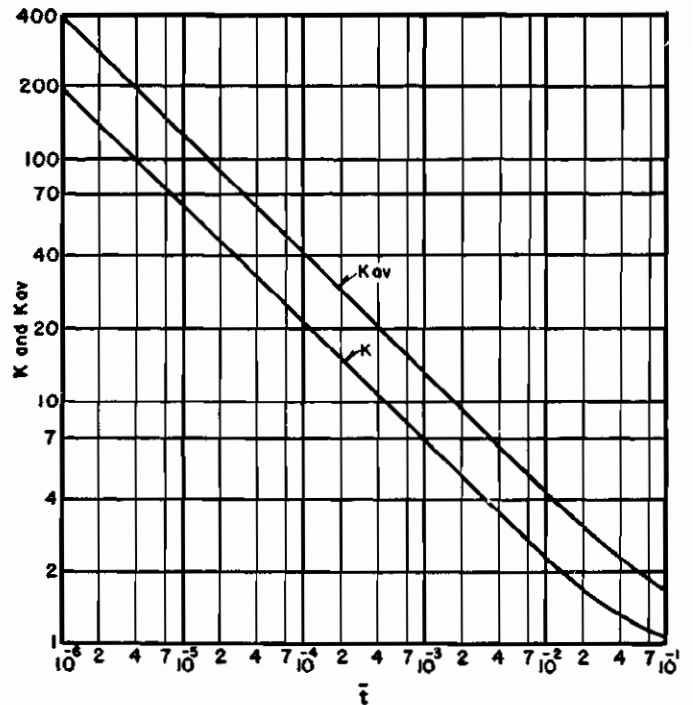

Fig. 33—Ratios of effective resistance to d-c resistance for a solid round conductor.

interior until at long times it is uniformly distributed over the cross section.

Let K define the ratio of the instantaneous resistance to the d-c resistance, and K_{av} the average of K up to the time t . Values of these quantities are given in Fig. 33. As a numerical example of the use of Fig. 33, suppose a constant current suddenly is applied to a solid copper rod $\frac{1}{2}$ inch in diameter, for which b is then $\frac{2.54}{2 \times 2} = 0.635$ cm. The values of t , K and K_{av} for various times is given by Table 1.

TABLE 1—VALUES OF \bar{t} , K , AND K_{av} FOR DIFFERENT TIMES

t	10^{-7}	10^{-6}	10^{-5}	10^{-4}
\bar{t}	3.35×10^{-6}	3.35×10^{-4}	3.35×10^{-3}	3.35×10^{-2}
K	36	12	3.6	1.4
K_{av}	70	22	7.0	2.5

These values give upper limits. For other than abrupt waves the effective resistance is smaller.

28. Empirical Data on Attenuation

Studies made by several investigators with klydographs have yielded data on the attenuation of the crest magnitude of voltage waves due to lightning¹⁴⁻¹⁸. An empirical formula has been developed by Foust and Menger¹⁸ to fit such data. This formula, which assumes that the loss in the wave is proportional to the third power of the voltage, is shown in Fig. 34. Its absolute value depends upon the arbitrary constant K . In Fig. 34 are plotted curves from this formula which represent the envelope of all available field data and a curve which represents a common mean. Other empirical formulae have also been developed^{2,20} which correspond (with the proper choice of the arbitrary constants) fairly closely to the

Foust and Menger formula in the high voltage range. Formulae of this type do not take into account the various important factors controlling attenuation and serve only to indicate its order of magnitude. Since the effect of distortion is not considered, the curves of Fig. 34 can be used for estimating purposes to determine the attenuation of the crest in a given distance for a surge of a given initial crest voltage by using the point on the curve corresponding to the initial voltage as a reference point. For example, examination of the mean curve of Fig. 34 indicates that a 2 000 kv surge will be attenuated to 750 kv in 6 miles and a 1 000 kv surge to 750 kv in 2.5 miles.

Since at the higher voltages corona is the most important factor, the effects of wave shape, polarity, and line construction on attenuation can be explained on the basis of their effect upon corona. Thus surges on large conductors should be attenuated more slowly than on small conductors. Likewise positive surges should be attenuated more rapidly than negative ones since corona loss is greater for positive waves.

The effect of some of the more important factors are shown by the curves of Fig. 35 obtained from studies with artificial surges. The curves give the effect of polarity and wave shape showing that short surges are attenuated more rapidly than long ones. Surges of the same voltage propagating on more than one conductor are shown to be attenuated less than a surge on only one conductor.

Ground wires appear to have slight effect on attenuation. Brune and Eaton⁹ found that at high voltages ground wires increased the attenuation slightly but at lower voltages decreased it. This appeared to be true for both polarities. McEachron, Hemstreet, and Rudge⁶, however, found that positive surges were not affected by the presence of a ground wire while negative surges were attenuated less.

In using the data of Fig. 34, the evidence indicates that the information from sharp chopped waves lay closer to the dotted curves and that information from slower waves lay closer to the dashed curve.

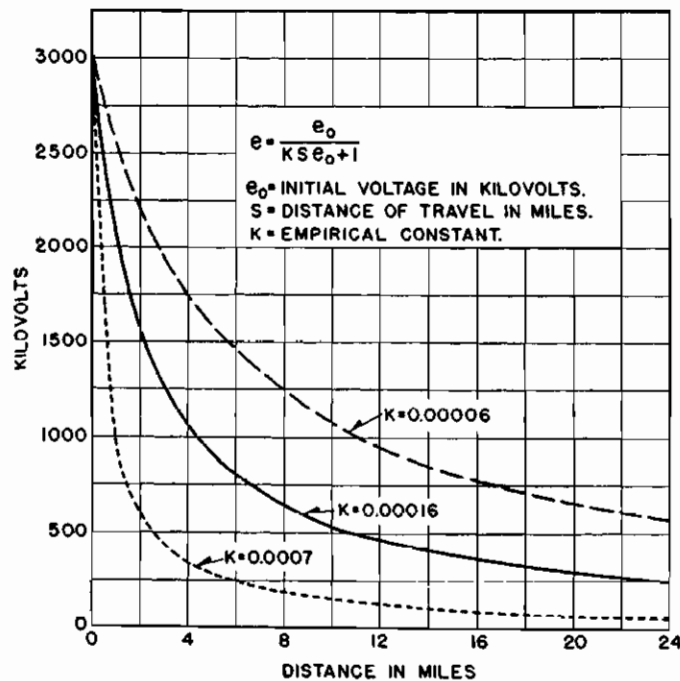

Fig. 34—Foust and Menger formula for determination of attenuation of crest magnitudes of voltage waves.

29. Corona

Attempts have been made to obtain analytical expressions for the effect of corona on distortion^{20,22}. The best picture of the mechanism of corona power loss at the present time seems to be the following as given by Skilling and Dykes²²: "There is a critical electric gradient for air that cannot be exceeded. Any attempt to increase it results in profuse ionization of the air, and the charges liberated by ionization take up such positions in space that the gradient does not exceed this value.

"Shortly after its formation space charge becomes relatively immobile, probably due to the formation of relatively heavy ions whose mobility is almost negligible compared to electrons.

"The supply of space charge to the region about a conductor increases as long as the voltage increases and energy must be supplied for their formation from the conductor.

"After the crest of a voltage wave is reached and begins to decrease, the space charge remains practically constant in magnitude and position. During this time there is little

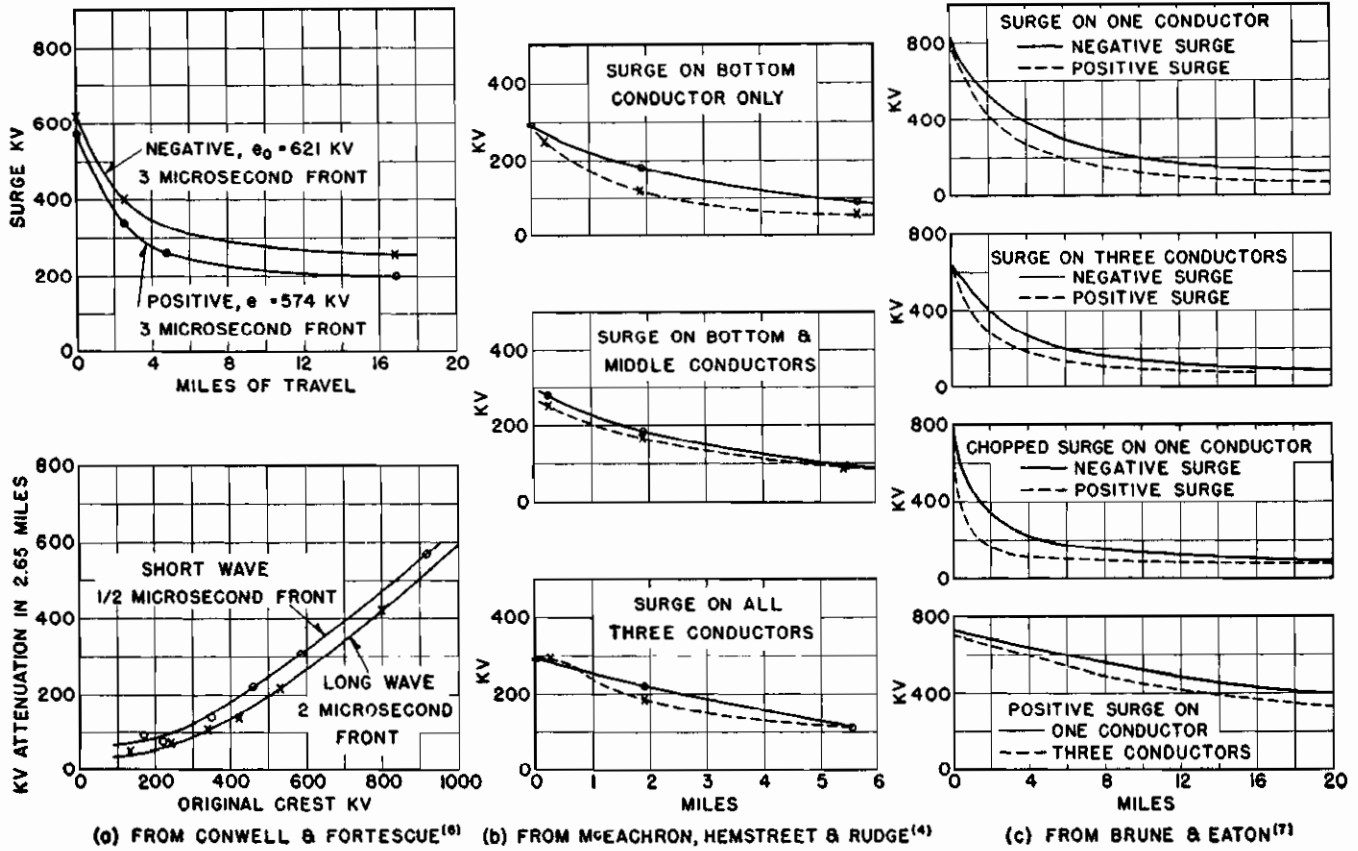

Fig. 35—Effect of the more important factors on attenuation.

(a) Effect of polarity and wave length. (b) Effect of propagation on more than one conductor. (c) Effect of polarity and propagation on more than one conductor.

loss in energy from the conductor, what there is being due to diffusion of ions in the electric field at a slow rate."

Skilling and Dykes²² have developed an analytical method of determining the distortion which is produced by conversion of a portion of the energy of the wave into corona loss as the voltage rises to crest value. This decreases the net stored energy of the wave. Line loss is neglected after the voltage crest is reached. Distortion of the tail is not considered, and it is assumed that the crest of the wave is moved along the original tail. Examination of oscillograms showing corona distortion such as those of Fig. 31 indicate that this is a good assumption. The equation which they use for the energy per unit length of the wave is the following

$$\text{Energy} = \frac{1}{C} e^2 \quad (109)$$

which neglects distortion and the formation of space charge. The quadratic formula for corona loss per unit length is used in the form

$$\text{Loss} = \frac{K}{n} (e - e_0)^2 \quad (110)$$

where e_0 is the critical corona voltage and K and n are empirical constants which will be discussed later. This type of expression for power frequency corona loss was developed by Peek.

With analytical expressions for the initial surge voltage as given by the following

$$e = f_0(t) \quad (111)$$

or $t = F_0(e) \quad (112)$

The equations which they developed for the corresponding quantities after the wave has propagated a distance x are

$$e = f_0 \left(t - \frac{K(e - e_0) + nCe}{nCv} x \right) \quad (113)$$

$$t = F_0(e) + \frac{K}{nCv} \left(\frac{e - e_0}{e} \right) x + \frac{x}{v} \quad (114)$$

where

t = time in seconds

e = voltage in volts

e_0 = corona starting voltage in volts (crest)

v = velocity of propagation of the wave in feet per second.

$$= 9.84 \times 10^8$$

C = capacitance of line in farads per foot

x = distance of travel in feet

K = the constant of Eq. (110) which relates crest voltage in volts to energy loss in joules per foot per half cycle, and which may be found from Peek's quadratic law or otherwise. It is equal to Peek's constant (which is expressed in kilowatts per kilovolt per mile) multiplied by

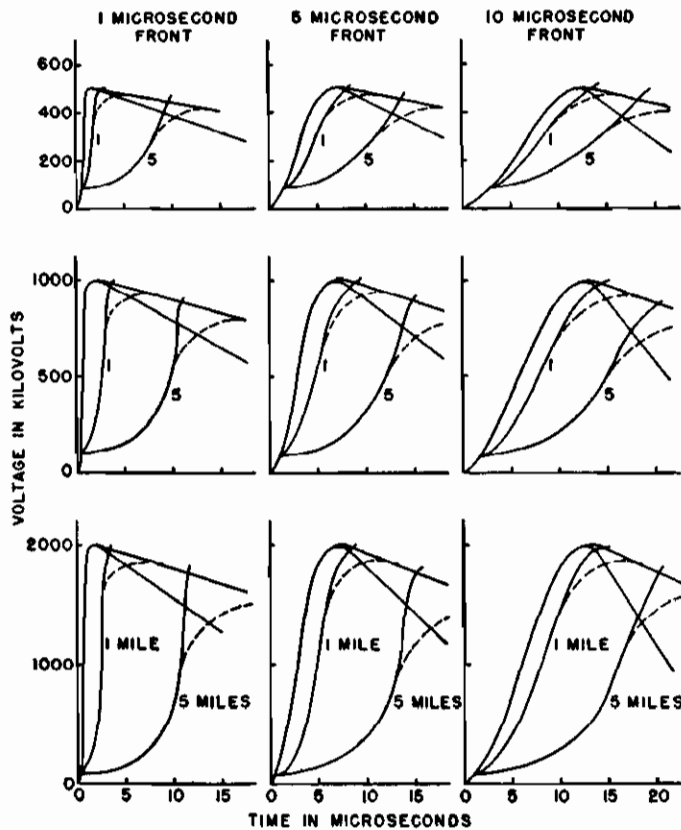

Fig. 36—Effect of corona in sloping the front of negative-voltage waves of different fronts and magnitudes.

$\left(\frac{10^3}{5280 \times 10^6} = 1.895 \times 10^{-7}\right)$. For high voltage transmission lines K is of the order of 4×10^{-12} .

Skilling and Dykes describe the constant n as follows: "The factor n is a more or less constant factor which is needed to account for three differences between the corona of traveling waves and corona at power frequency. These are (1) the effect of mobility of charge (2) the fact that when voltage is alternating there is a space charge left over from one-half cycle to the next, and (3) the difference between positive and negative corona."

They found that good results could be obtained if $n = 2\frac{1}{2}$ for positive waves and $n = 4$ for negative waves.

Eq. (114) is more convenient for an actual calculation. This equation shows that at a distance x for every value of e on the front of the original wave there is a new value of t . If there were no distortion this would be the original value $F_0(e)$ from Eq. (112) plus $\frac{x}{v}$ the term which represents the time for the wave to travel the distance x . The term $\frac{K}{nCv} \left(\frac{e-e_0}{e}\right)x$ describes the distortion of the wave produced by corona. It is not necessary to know the analytical expression for the initial wave. The wave can be plotted graphically and successive values of voltage selected on the front of the wave with their corresponding times. To obtain the time it takes the voltage to rise from zero to this same value after the wave has traveled the distance x it is merely necessary to add to the initial time

the value $\frac{K}{nCv} \left(\frac{e-e_0}{e}\right)x$. In this manner the front of the distorted wave can be plotted. The crest of the wave is determined by plotting the distorted wave on the same figure with the initial wave, starting both at the same point. The crest is the point of intersection of the distorted front with the tail of the initial wave.

A comparison of calculations of distortion using this formula with oscillograms of actual cases is shown in Fig. 31 where the solid curve expresses waves calculated by Skilling and Dykes. As seen by these curves the calculated results conform closely to the oscillograms above the critical voltage except at the crest of the wave.

In order to obtain a better idea of the effect of corona in sloping off the front of voltages high enough to be of importance from an insulation standpoint calculations were made of the distortion of waves of different fronts and magnitudes after traveling different distances. These are shown in Fig. 36.

VI. 60-CYCLE STEADY-STATE PERFORMANCE

Misunderstanding sometimes occurs in the application of wave theory to the steady-state 60-cycle operation of transmission lines. This occurs particularly with regard to the no-load condition. The question is frequently asked, "Since it is known that the waves travel with the speed of light, should there not be a phase-angle displacement between the two ends of the line equivalent to the time required for the wave to travel the length of the line?" Actually, of course, at no load the phase displacement is very low and if the resistance is equal to zero the phase angle is also zero. This difficulty is resolved when the reflections are taken into consideration. To clarify this situation, consideration will be given to some simple 60-cycle conditions as applied to a resistanceless line.

As was shown in Section 10 of this chapter, if a resistance, equal to the surge impedance, is connected in shunt across the receiving end of a resistanceless line and a surge is impressed upon the line, no reflections occur at the receiving end. Under these same line conditions, if a 60-cycle voltage is impressed across the sending end, waves of voltage propagate along the line and no reflections occur. Since waves travel with the speed of light, 186 000 miles per second, then a full wave or 360 degrees phase displacement occurs on a $\frac{186\ 000}{60}$ or 3100-mile line. The phase displacement for a 300-mile line is $\frac{300}{3100} 360$ or 34.8 degrees and the voltages at the two ends are equal in magnitude.

The amount of power absorbed in the resistor $\left(\frac{E^2}{Z}\right)$, on a three-phase basis, where E is the line-to-line voltage) can be transmitted an indefinitely long distance with constant voltage all along the line. At this load the capacitive charging kva just equals the inductive reactive kva of the inductance. This particular load is called the "surge impedance load." If the resistance, which might be characterized as a "dead" load is replaced by synchronous equipment, other factors enter which limit the amount of

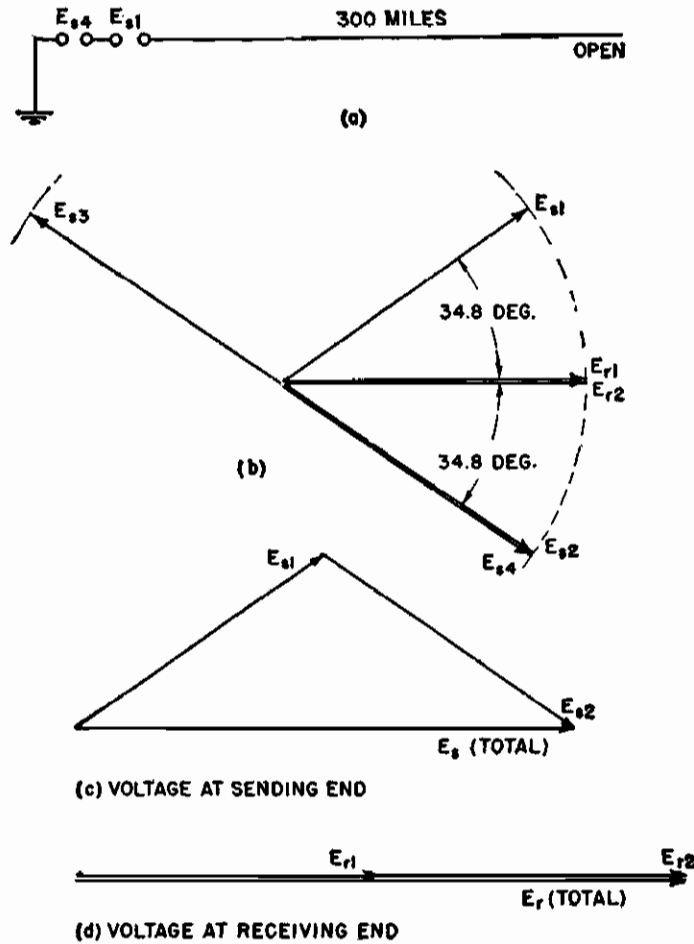

Fig. 37—Steady-state analysis by means of wave theory of an open-circuited resistanceless line 300 miles in length.

power that can be transmitted. For detailed consideration of these factors see the chapter on System Stability.

Now returning to the open circuit, let the voltage whose vector (or phasor) value is indicated by E_{s1} of Fig. 37 be impressed across the sending end of a 300-mile line. At a time later represented by the time required for the wave to traverse the line (34.8 deg.) the wave, E_{r1} , reaches the end of the line and is reflected with equal magnitude and phase position, E_{r2} . This wave reaches the sending end with a magnitude and phase position given by E_{s2} . This voltage is reflected with opposite polarity as given by E_{s3} . Now impress upon the line an additional voltage given by E_{s4} which is equal to E_{s2} . The purpose of this additional voltage is to annul the effect of E_{s3} in so far as the line is concerned. Both E_{s3} and E_{s4} propagate along the line but since they are equal and opposite they cancel each other. All reflections are now provided for adequately. At the sending end are the voltages E_{s1} , E_{s2} , E_{s3} and E_{s4} which add up to $E_{s(\text{total})}$ in (c). At the receiving end are the voltages E_{r1} and E_{r2} . Thus the voltage at the receiving end is in phase with that at the sending end and is greater by the reciprocal of the cosine of 34.8 degrees or 1.218.

REFERENCES

1. Mechanical Demonstrator of Traveling Waves, by C. F. Wagner, *Electrical Engineering*, October, 1939, page 413.
2. Traveling Waves on Transmission Systems, by L. V. Bewley (a book), John Wiley and Sons.
3. Theoretical and Field Investigations of Lightning, by C. L. Fortescue, A. L. Atherton, and J. H. Cox, *A.I.E.E. Transactions*, Volume 48, 1929, page 449 (395).
4. Cathode Ray Oscillograph Study of Artificial Surges on the Turner Falls Transmission Line, by K. B. McEachron and V. E. Goodwin, *A.I.E.E. Transactions*, 1929, Volume 48, page 475 (475).
5. Study of the Effect of Short Lengths of Cable on Traveling Waves, by K. B. McEachron, J. G. Hemstreet, and H. P. Seelye, *A.I.E.E. Transactions*, Volume 49, 1930, page 1432 (527).
6. Traveling Waves on Transmission Lines with Artificial Lightning, by K. B. McEachron, J. G. Hemstreet, and W. J. Rudge, *G. E. Review*, April, 1930, page 254 (722).
7. Symposium on Lightning, by J. H. Cox and Edward Beck, *A.I.E.E. Transactions*, Volume 49, 1930, page 857 (732).
8. Lightning Laboratory at Stillwater, New Jersey, by R. N. Conwell and C. L. Fortescue, *A.I.E.E. Transactions*, Volume 49, 1930, page 872 (746).
9. Experimental Studies in the Propagation of Lightning Surges on Transmission Lines, by O. Brune and J. R. Eaton, *A.I.E.E. Transactions*, Volume 50, 1931, page 1132 (813).
10. Attenuation and Successive Reflections of Traveling Waves, by J. C. Dowell, *A.I.E.E. Transactions*, Volume 50, 1931, page 551 (855).
11. *Electric Circuit Theory and Operational Calculus* (a book), John R. Carson, McGraw-Hill Book Company.
12. *Elektrische Schaltvorgänge*, by R. Rudenberg (a book), Julius Springer, Berlin.
13. Diffusion of Electric Current Into Rods, Tubes and Flat Surfaces, by K. W. Miller, *A.I.E.E. Transactions*, Volume 66, 1947, page 1496.
14. Lightning Investigation on the Ohio Power Co.'s 132-kv System — 1930, by Philip Sporn and W. L. Lloyd, Jr., *A.I.E.E. Transactions*, Volume 50, 1931, page 1111 (659).
15. Lightning Investigation on the 220-kv System of the Penn. Power & Light Co. 1930, by Edgar Bell and A. L. Price, *A.I.E.E. Transactions*, Volume 50, 1931, page 1101 (691).
16. Lightning Investigation on 220-kv System of the Penn. Power and Light Co. 1928-1929, by N. N. Smeloff and A. L. Price, *A.I.E.E. Transactions*, Volume 49, 1930, page 895 (712).
17. Lightning Investigation on the Appalachian Electric Power Co.'s Transmission System, by I. W. Gross and J. H. Cox, *A.I.E.E. Transactions*, Volume 50, 1931, page 1118 (818).
18. Surge Voltage Investigations on Transmission Lines, by W. W. Lewis, *A.I.E.E. Transactions*, Volume 47, 1928, page 1111 (281).
19. Corona and Line Surges, by H. H. Skilling, *Electrical Engineering*, Oct. 1931.
20. The Hysteresis Character of Corona Formation, by H. J. Ryan and H. H. Hemline, *A.I.E.E. Transactions*, Volume 50, 1931, page 798.
21. Discussion, by E. W. Boehne, *A.I.E.E. Transactions*, Volume 50, 1931, page 558.
22. Distortion of Traveling Waves by Corona, by H. H. Skilling and P. deK. Dykes, *A.I.E.E. Transactions*, Volume 56, 1937, page 850.

NOTE: Number in parentheses indicates page number in Lightning Reference Book.

CHAPTER 16

LIGHTNING PHENOMENA*

Original Authors:

C. F. Wagner and G. D. McCann

Revised by:

C. F. Wagner and J. M. Clayton

I. GENERAL CHARACTERISTICS

THE physical manifestations of lightning have been with us from the remotest times, but only comparatively recently have the phenomena become even partly understood. Franklin in his electrical experiments between 1740 and 1750 succeeded in identifying lightning as the static electricity of his time. Beyond this fact little was learned until within the past 35 years. The real incentive to obtain additional knowledge lay in the necessity of the electrical industry to protect against its effects. As longer transmission lines were built the need for reduction in outages due to lightning became more acute. This placed more stringent requirements upon lightning arresters and other protective devices. Largely through the co-operation of the utilities and manufacturers and through the use of special instruments such as the klydonograph, cathode-ray oscillograph, surge-crest ammeter, Boys camera, and fulchronograph, information of a very valuable character has been obtained regarding stroke mechanism and the voltages and currents associated with lightning.

1. Charge Formation

In spite of the great interest in the manner in which charges arise in thunderclouds, the question is still controversial. Some half-dozen theories have been advanced, but those of C. T. R. Wilson and of G. C. Simpson or modifications of them have received most consideration. Both theories postulate ascending currents of air and relative motion of rain drops of different sizes.

Wilson's theory¹ depends for its explanations upon the presence of large numbers of ions in the atmosphere. Many of these ions, both positive and negative, attach themselves to minute particles of dust and extremely small drops of water, called Aitken nuclei, to form large ions as contrasted with unattached or small ions. Over land the number of small ions of each sign ranges from about 300 to 1000 per cubic centimeter, and the large ions from 1000 to 80 000 per cubic centimeter. The small ions do not play an important part in Wilson's theory. The mobility of an ion is the steady velocity that can be attained under a voltage gradient of one volt per centimeter. The large ions have very low mobility ranging from 0.0003 to 0.0005 centimeter per second. Under a gradient of 10 000 volts per centimeter this would correspond to a velocity of only 3 centimeters per second.

Macky², in a study of the behavior of water drops when exposed to electric fields, found that a droplet of radius p

centimeters becomes elongated until at a critical field determined by the relation $F\sqrt{p} = 3875$ it becomes unstable. A luminous glow is formed at each end and the energy absorbed thereby results in evaporation of a portion of the water forming the droplet. This sets a limit to the size of drops in a thunderstorm. Thus, no drops greater than 0.15 centimeter in radius can persist in fields of 10 000 volts per centimeter. Air pressure has no influence upon the field at which this occurs. Macky suggests that in general the fields within thunderstorms will rise to a value of the order of 10 000 volts per centimeter before discharge occurs.

Wilson's theory premises the existence of the normal field which occurs during fair weather. This is generally directed downward, the direction which convention has adopted as positive. In magnitude it is of the order of one volt per centimeter at the surface of the earth and gradually decreases with altitude until at 30 000 feet it is only about 0.02 volt per centimeter. A relatively large drop of water (of say one millimeter radius) in such a field will become polarized by induction, the upper side acquiring a negative charge and the lower side a positive charge (see Fig. 1). The velocity of fall under the influence of gravity of such a charge will be 590 centimeters per second, which is large with respect to the velocity of the slowly moving ions even under the maximum field strength of 10 000 volts per centimeter. At the under surface of the drop a selective action with regard to the slowly moving ions occurs. The negative ions tend to be attracted and the positive ions repelled. No such selection occurs at the

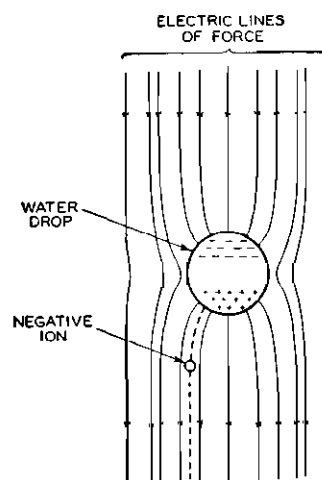

Fig. 1—Capture of negative ions by large falling drops.

*The material in sections I and II of this chapter is essentially the same as that presented in a series of articles by the original authors that appeared in August, September, and October, 1941 issues of *Electrical Engineering*. The material in section III is revised to include the results of field studies through 1949.

upper surface. As a result of this action, the drop accumulates negative charge. With the loss of the negatively charged ions the remaining large ions are predominantly positive. The smaller drops descend with a lower velocity and thus their velocity becomes more nearly equal to that of the velocity of the large ions under the influence of the electric field. It becomes possible then for the small drops of water to pick up positive charge by impact with the positive ions.

Thus, the original charges which were distributed at random and produce an essentially neutral space charge, become separated. The large drops carry the negative charges to the lower portions of the cloud and the small drops retain the positive charge in the upper portion. According to Wilson's theory the lower portion of the cloud is negatively charged and the upper portion, positively. This mechanism of discharge has been verified experimentally in the laboratory by Gott³ who actually obtained charge separation by this process.

The theory of G. C. Simpson⁴ also has been substantiated in part by laboratory experiments. It has been shown that a water drop of radius greater than 2.5 millimeters becomes flattened or unstable when it falls through still or ascending air. A large number of smaller drops are formed. The terminal or steady-state velocity of drops 0.25 centimeter in diameter is eight meters per second, which thus constitutes the limiting relative velocity of rain drops. No drops will fall to earth in an ascending current of air exceeding eight meters per second. It has also been shown that when water drops break up, the resulting droplets become positively charged and the air negatively.

The meteorological conditions within a cloud according to Simpson are shown in Fig. 2. The unbroken lines rep-

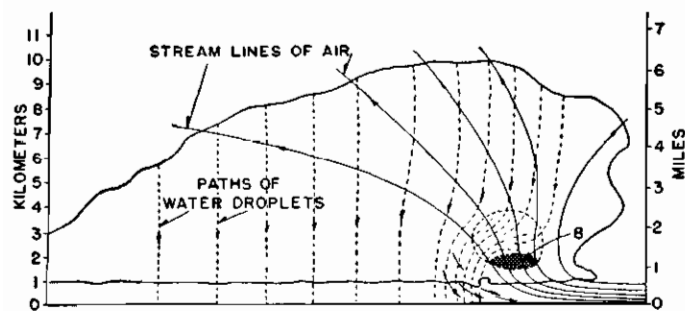

Fig. 2—Meteorological conditions within thunderclouds, according to Simpson.

resent lines of flow of the air, their distance apart being inversely proportional to the wind velocity. The air enters the storm from the right and passes under the forward end of the cloud where it takes an upward direction. Within the cross-hatched oval marked 8 the vertical component of the wind is more than eight meters per second; and outside less. For the reason just stated no water can fall through this area. The dotted lines show the general path of the larger drops as they fall to earth. The balloon-like surface of which the oval 8 forms the bottom represents a boundary within which the upward velocity is still very high. Only the larger drops are able to descend within the volume so formed and none are able to penetrate the

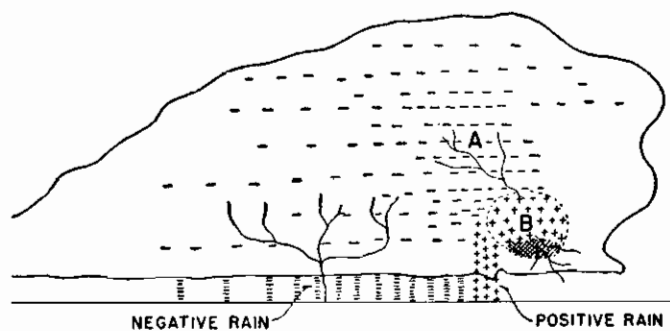

Fig. 3—Electrical conditions within thunderclouds⁴.

oval 8. The drops that do fall within this volume will be broken and the parts blown upward. The small drops that have been blown upward will recombine and fall back again, and so the process will be continued.

The distribution of electrical charge that will result from the conditions represented in Fig. 2 is shown diagrammatically in Fig. 3. The mechanism by which charge separation occurs is explained clearly by Simpson as follows:

"In the region where the vertical velocity exceeds eight meters a second there can be no accumulation of electricity. Above this region where the breaking and recombining of water drops take place (the region marked *B* in Fig. 3) here, every time a drop breaks, the water of which the drop is composed receives a positive charge. The corresponding negative charge is given to the air and is absorbed immediately by the cloud particles, which are carried away with the full velocity of the air current (neglecting the effect of the electrical field in resisting separation). The positively charged water, however, does not so easily pass out of the region *B*, for the small drops rapidly recombine and fall back again, only to be broken once more and to receive an additional positive charge. In this way the accumulated water in *B* becomes highly charged with positive electricity, and this is indicated by the plus signs in the diagram. The air with its negative charge passes out of *B* into the main cloud, so that the latter receives a negative charge. In what follows, the region *B* will be described as the region of separation, for here the negative electricity is separated from the positive electricity. The density of the negative charge obviously will be greatest just outside the region of separation, and this is indicated in Fig. 3 by the more numerous negative signs entered in the region around *A*."

In contrasting the two theories, it may be observed that Wilson's theory leads to the conclusion that the lower portion of a cloud is negatively charged and the upper portion positively. Simpson's theory as given above, on the other hand, leads to the converse—that an intense positive charge resides in the head of the cloud and that negative charge is distributed throughout the rest of the cloud. Wilson's experimental observations of field changes next to the ground indicated that a charge of positive electric moment, that is, a charge distribution equivalent to a positive charge above a negative charge, is destroyed in the process of most lightning discharges. In addition the results of magnetic-link investigations on electrical systems, as discussed hereinafter, indicate that approximately 90 percent of all strokes lower negative charge to the transmission system.

The direct contradiction between these two theories led Simpson and Scrase⁵ to investigate the charge distribution

in a more direct manner. Free balloons equipped with clock-operated apparatus to measure electric gradient, atmospheric pressure, and relative humidity were released during storms. It was found that in general the main body of a thundercloud is negatively charged and the upper part positively charged. A concentration of positive charge appears to exist frequently in the base of the cloud. According to Simpson and Scrase the cloud structure of the type shown in Fig. 4 offers a satisfactory explanation of

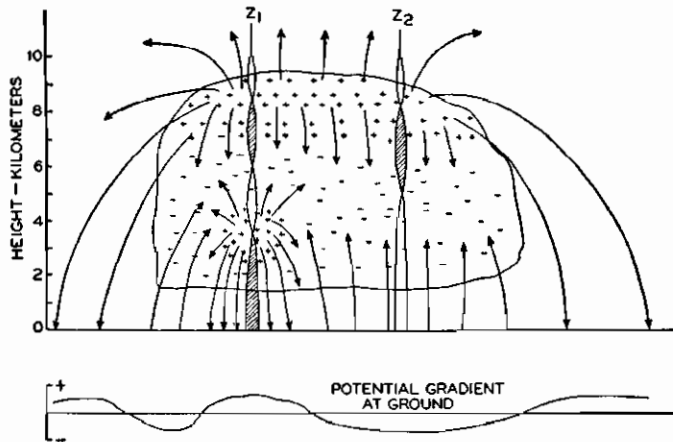

Fig. 4—Hypothetical case of a cloud with a positive charge in the upper part, a negative charge in the lower part and a small region of strong positive charge near the base.

practically all the soundings obtained in their investigations. The positive charge at the top of the cloud gives rise to the positive field encountered at the ground as the storm approaches and as it recedes. The negative charge contained in the lower half produces a negative field everywhere under the cloud except where the local concentrations of positive electricity produce positive fields. Further verification of this fact is offered by data obtained by Simpson and Scrase by recording ground gradients during the passage of storm clouds. From the records of 20 storms it was found that the average length of time for which the potential gradient was appreciably disturbed from its fine-weather value was 75 minutes. By centering each record about the midpoint of the total period and dividing the record into five-minute intervals, the curve in Fig. 8 shows the percentage of frequency of positive potential gradient. The parts of the curve above the line corresponding to 50 percent represent a preponderance of positive gradient and those below a preponderance of negative gradient. It shows that the approach and recession of a storm usually are accompanied by positive gradients while the center of the cloud produces a negative gradient. This is what would occur if the lower portion of the cloud carried negative charge and the upper portion positive charge.

As between the Simpson and Wilson theories, the induction theory of Wilson seems to offer an adequate explanation of negative charge in the lower regions of the cloud and the concentration of positive electricity higher up in the cloud. It does not explain the positive charge found at the base of the clouds. However, quoting from Simpson and Scrase:

“Our observations have shown quite conclusively that the boundary between the positive electricity in the upper part of the cloud and the negative electricity in the lower is in every case in a region of the cloud where the temperature is well below the freezing point and generally below -10 degrees centigrade. In this part of the cloud raindrops cannot exist. The cloud particles may be supercooled water, but on coalescing they would immediately freeze. The precipitation in the upper part of a cloud is in the form of crystals, either needles or plates, which tend to lie horizontally and to fall slowly in a series of nearly horizontal motions, first in one direction and then in another. These crystals cannot play the role of the raindrops in Wilson’s theory, for in the first place they are nearly perfect nonconductors and so do not become electrically polarized, and, even if they do conduct, their shape and orientation is not favorable to the formation of induced charges, and finally their rate of fall relatively to the air is very slow. It is clear, therefore, that Wilson’s influence theory cannot explain the separation of the charges found in the upper part of the thunder-clouds.

“It is well known that during blizzards in polar regions which are accompanied by large masses of blown snow, very strong electrical fields are set up near the earth’s surface. These fields, with very few exceptions, are positive in direction; that is to say, in the same direction as the field in the upper part of a thundercloud. Simpson, in his discussion of the observations made in the Antarctic (Simpson 1919), suggested that the impact of ice crystals results in the ice becoming negatively charged and the air positively charged. The general settling of the negatively charged ice crystals relatively to the positively charged air would then result in a separation of electricity with the positive charge above the negative. This explanation, however, has not yet been confirmed by satisfactory laboratory experiments. Whatever the physical explanation may be, there seems little doubt that the upper separation of charge in a thunderstorm is in some way connected with the presence of ice crystals.

“There appear therefore to be two different physical processes taking place in a thunderstorm to produce the electrical effects: One is confined to the upper parts of the cloud where the temperature is below the freezing point, and the second occurs in the lower part of the cloud where the temperature is above the freezing point. There is reason to believe that the former is associated with the presence of ice crystals and the latter with raindrops, probably in the way described by Simpson in his breaking-drop theory.”

Fig. 5 represents Simpson’s revised diagram to illustrate the meteorological and electrical conditions in a thundercloud. This differs from his early conception illustrated in Fig. 3, in that a positive charge resides in the upper portion of the cloud above a region of separation from the negative charge, in which the temperature is between -10 and -20

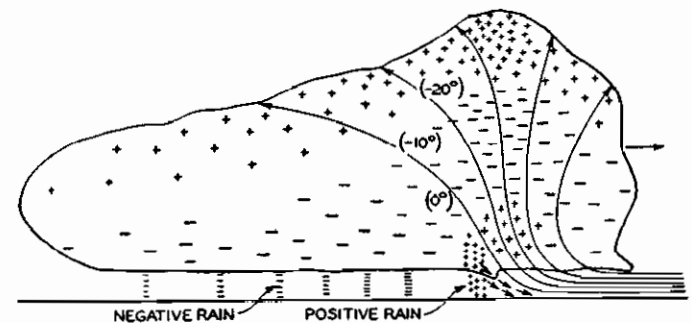

Fig. 5—Meteorological and electrical conditions within a thundercloud, according to Simpson’s revised theory.

degrees centigrade. More recent investigations of Simpson and Robinson⁶ further corroborate these concepts of the three distinct regions of charge distribution. They also more firmly establish that the separation of the positive charge in the upper region from the negative charge in the main body of the cloud takes place at temperatures below freezing, while the positive-charge center found at the base of the cloud is separated at a temperature above freezing.

W. J. Humphreys⁷ offers a modification of Simpson's breaking-drop theory. He retains the experimentally verified fact that when a neutral drop is broken up by a jet of air, the spray particles are negatively charged and the larger remaining particles positively charged. It has been observed, principally by aviators, that the mean level at which the maximum vertical velocity of air occurs is well above the halfway point between the base and top of the thundercloud. This velocity is commonly so great that raindrops cannot fall through the air at its level. Therefore, the greatest concentration of raindrops occurs at this point and the seat of the most active electric separation must be at a still higher level—the level at which drops can just maintain their position against the ascending air. The negative electricity presumably is first carried to or near to, the top of the cloud and from there pulled down along, or near to, the cloud wall by the descending air that commonly flows down the sides, incident to cooling caused by evaporation. According to this explanation, a net positive charge will occur above the midlevel of the cloud and the negative charge will be distributed more generally throughout the cloud body. This theory does not accept the subzero temperature region of separation between the negative and positive charges as put forward by Simpson.

E. J. Minser,⁸ however, largely from observations of aviators, retains the conception of a region of subzero temperature as an essential factor in the explanation of the charge generation within a cloud. He has found that cloud masses of high electric charge exist not only in the cumulo-nimbus cloud but also in the cumulus cloud of the shower type. His explanation is based on a combination of the Wilson and Simpson theories plus the ice-crystal theory of precipitation suggested by Bergeron.

The processes occurring within cloud formations are so complicated that it is quite possible that all the foregoing phenomena—the electrification resulting from breaking drops, the selective attraction by polarized drops, and interactions between wind and ice crystals at subzero temperatures—are involved.

2. Rate of Charge Accumulation

The rate at which the charge accumulates is relatively slow as evidenced by the measurements of ground gradients by Wilson⁹ and others.¹⁰ Fig. 6 is a typical record obtained by Wilson which shows both the magnitude and manner of variation of this quantity. The division between the solid black and shaded areas indicates the magnitude of the gradient according to the scale at the left-hand side. Sudden discontinuities such as that at *A* represent the destruction of a portion of the gradient as the result of a lightning stroke. The single dark line at *a* and the double dark line at α indicate the time of the beginning and end,

respectively, of thunder arising from the stroke at *A*. From this record Wilson calculated that this particular stroke was 7.1 kilometers distant from the observation station. Points *B*, *b*, and β are similarly associated. Immediately after the occurrence of a stroke the regenerative processes within the cloud begin to re-establish the field at the rate indicated by the rate of change of the gradient.

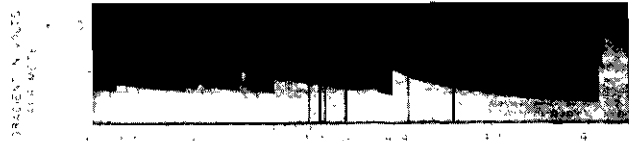

Fig. 6—Measurement by Wilson of ground gradient during a thunderstorm.

It can be seen that in general the curve is exponential in character and requires many seconds before the charging process attains a substantially constant value. The prominence at 14 hours 12 minutes 30 seconds was produced by the measuring device to establish the zero line and is not a record of change in gradient caused by a stroke.

3. Cloud Heights

A search of the literature reveals very little definite data regarding the height at which the stroke can be said to originate. Simpson and Scrase⁵ from a limited number of observations in England estimate charge centers as occurring as low as 1500 feet and as high as 30 000 feet. Of course, the origin of the stroke may not coincide with the charge center but may lie between the charge center and the base. E. J. Minser, chief meteorologist of Transcontinental and Western Air, Inc., has observed that the altitude of the base of low-level thunderclouds frequently lies between 500 and 1000 feet. He further states that his studies show that the majority of lightning discharges have occurred in the cumulus clouds of the shower type and that strokes to ground occur most frequently from clouds having the lower altitudes. Data in possession of the United States Weather Bureau indicate cumulo-nimbus clouds as having a mean ceiling of 5500 feet with some of them as low as 600 to 700 feet. Thunderstorms for which the ceiling is practically zero are also reported at times. Instances in which the storm clouds actually envelop mountains rising from a plain are quite common.

4. Charge and Field Distribution

Fig. 7, taken from Simpson and Scrase's paper, shows also that the fields and consequently the charge densities are quite variable. The thickness of the vertical columns is a measure of the potential gradient, the shaded portion indicating a positive field and the unshaded portion a negative field. The maximum gradient that could be recorded in the balloon experiments of Simpson and Scrase⁵ and Simpson and Robinson⁶ was about 100 volts per centimeter. It was found that a gradient in excess of this amount very rarely was recorded in any of the balloon ascents, and it was concluded that the field in the thundercloud is of the order of 100 volts per centimeter except in relatively small regions of very great electrical activity

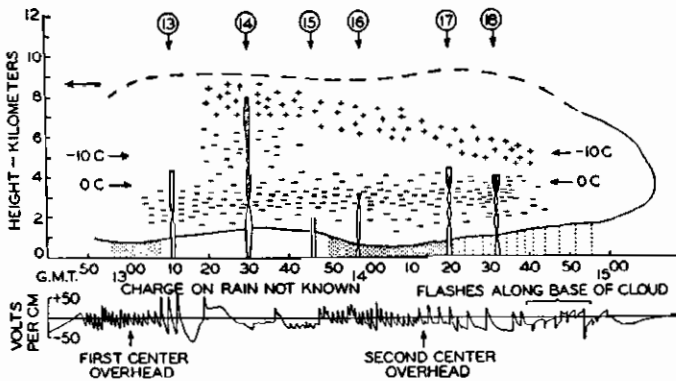

Fig. 7—Electric gradient by Simpson and Scrase⁵ with free balloons.

where the lightning discharges originate. They found no evidence of large horizontal sheets of positive and negative charge with electric fields approaching the breakdown strength of the air.

As shown in Fig. 7, Simpson and Scrase found that the field between cloud and ground was more or less independent of height and of the order of 50 to 100 volts per centimeter. Thus the gradient in the region between cloud and ground is about 1 000 000 volts per thousand feet so that for a 10 000 foot cloud the potential at the cloud base would be of the order of 10 000 000 volts. Taking into consideration the more intense fields near regions of high charge distribution, it is likely that cloud potentials are of the order of 20 000 000 volts.

5. Mechanism of Stroke

The electrical charge concentrations within a cloud, of course, must be limited to the bounds of the cloud proper and in most cases are much smaller. In relation to these dimensions the earth can be regarded as infinite in extent. It follows then, from consideration of a flux plot, such as that of Fig. 4, that before the discharge the electrical gradient within the cloud must be very much greater than at the earth where the gradient never exceeds about 100 volts per centimeter. Thus, the discharge tends to be initiated

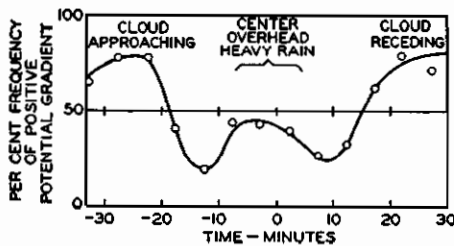

Fig. 8—Average frequency of occurrence of positive potential gradient at the ground during passage of a thundercloud⁵.

at the cloud rather than at the ground. As mentioned previously, the tests of Macky show that in a region occupied by water droplets of the size expected in clouds the critical breakdown voltage is 10 000 volts per centimeter, a magnitude contrasted with 30 000 volts per centimeter in air without water droplets. This phenomenon likewise tends to initiate the discharge from the cloud. In addition,

the lower pressure at the higher altitudes, even if there be no water droplets, decreases the breakdown gradient. On the other hand, tests indicate that discharges from positive terminals appear to require lower gradients than discharges from negative terminals, and since most discharges are from negative cloud sources, this property would tend to encourage the initiation of discharges from the ground.

What are the facts? The results of a large number of photographic records by Schonland¹⁸ indicate that all of the discharges he has observed were initiated from the cloud end rather than from the ground. McEachron¹¹ has shown that for the discharge of lightning to a very tall building the initial streamer usually proceeds upward from the building. In a later discussion¹² he states: "Thus far, I have no evidence that upward leader strokes occur to transmission lines of the usual height." The evidence, therefore, suggests that for the type of discharge with which these articles are largely concerned, namely, those to low structures, the initial discharge can be assumed to start from the cloud.

Present knowledge of the mechanism of stroke propagation is largely the result of the work of Schonland and his

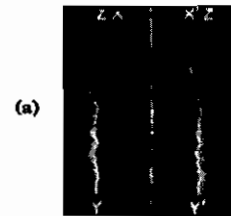

Fig. 9—Boys-camera photograph of lightning taken by Schonland¹³⁻¹⁷

associates in South Africa.¹⁵⁻¹⁷ Most of their data were obtained photographically by means of a Boys camera. The essential feature of the Boys camera is that it contains two lenses mounted diametrically to the axis about which the lens system rotates with respect to the film. The combination of the motion of the lenses and the propagation of the stroke produces two distorted pictures of the stroke from which, by superposing, one can deduce the direction and velocity of propagation of the stroke from the displacement between corresponding points on the two images. The speed of revolution of Schonland's Boys camera was 3000 rpm which permitted a resolution of the photograph of 0.3 microsecond. Fig. 9(a) shows a pair of these pictures mounted together.

A lightning discharge which usually appears to the eye as a single flash is in reality generally made up of a number of separate strokes that travel down the same path. The interval between these components varies between 0.0005 and 0.5 second. Each separate stroke starts as a downward leader from the cloud. When the downward leader strikes the ground it is followed by an intense return streamer which consists in a point of intense luminescence traveling from the ground to the cloud. The rather interesting properties of these phases of the flash are to be discussed subsequently in some detail. Fig. 9(b) is typical of the pictures obtained by Schonland. It shows a number of repetitive strokes. A slower camera of this general type permits the determination of the order in which the discharges occurred.

Initial Leaders—The leader of the first component stroke of a flash is preceded by a "pilot streamer" which represents propagation of the discharge into virgin air having very low ionization. Currents¹⁶ associated with the pilot streamer are small, the majority being of the order of only a few amperes. The luminosity is likewise very low—so low that it does not register on the photographic plate of a Boys camera. Its existence is deduced by inference and by an analysis of the mechanism of the discharge. In the following discussion velocities are given in terms of that of light (approximately 1000 feet per microsecond) as it is the same as that of waves on transmission lines, and, therefore, provides a very convenient bench mark when the phenomenon is applied to considerations of the effect upon systems. The most frequent velocity of propagation of the pilot streamer is about 1/20 of one percent of that of light.

As the pilot streamer proceeds, it is accompanied by points of luminescence which travel in jumps giving rise to the term "stepped leader." The velocity of these steps exceeds one-sixth of that of light and the distance traveled in one step is about 50 meters. The path of each step is essentially straight but each fresh step, in general, takes a different direction. The change in direction at each junction thus gives rise to the tortuous path characteristic of lightning. The electrostatic lines of force from the stroke to ground should form essentially smooth curves—another fact which suggests that the zigzag path must be attributable to some variable condition at the head of the discharge, this condition being either variations in the head itself or variations in space ionization. Fig. 10 shows a photograph of several such stepped leaders obtained by



Fig. 10—Boys-camera photograph by Schonland¹⁵⁻¹⁷ showing the "stepped leader."

Schonland by means of the Boys camera. The arrows indicate the direction of time, and the stepped leaders are shown to the right of the subsequent brilliant return stroke. As the leader seeks its way to earth, branches radiate from the main stem forming tentacle-like fingers spreading earthward. This stage of the process is shown in Fig. 11(a). A portion of the charge in the center from which the stroke originated is lowered and distributed over this entire system of temporary conductors. This process continues until one of the leaders strikes the earth. Short streamers have been observed to reach upward from the earth to meet the downward-moving leader just before it reaches the earth, but, in general, if such exist they must be short. Regarding this point, Schonland in a letter to the authors says:

"It must be remembered that the country in which we work consists of rolling hills and valleys, so that the base of the discharge is often obscured; there must, however, be a large number of cases in which the full length of the discharge was recorded by the cameras and we have seen no evidence of any extensive leader discharge from ground. Such leaders as do occur are comparatively short, for otherwise we should have detected them."

Return Stroke—As the leader strikes the ground an extremely bright return streamer propagates upward from the earth to the cloud following the same path as the main channel of the downward leader. The charge distributed along the leaders thus is discharged progressively to ground giving rise to the very large currents usually associated with lightning discharges—currents varying between 1000 and 200 000 amperes. The rate of propagation, about 10 per cent of that of light, is determined by the rate at which the head of the lightning channel can become sufficiently

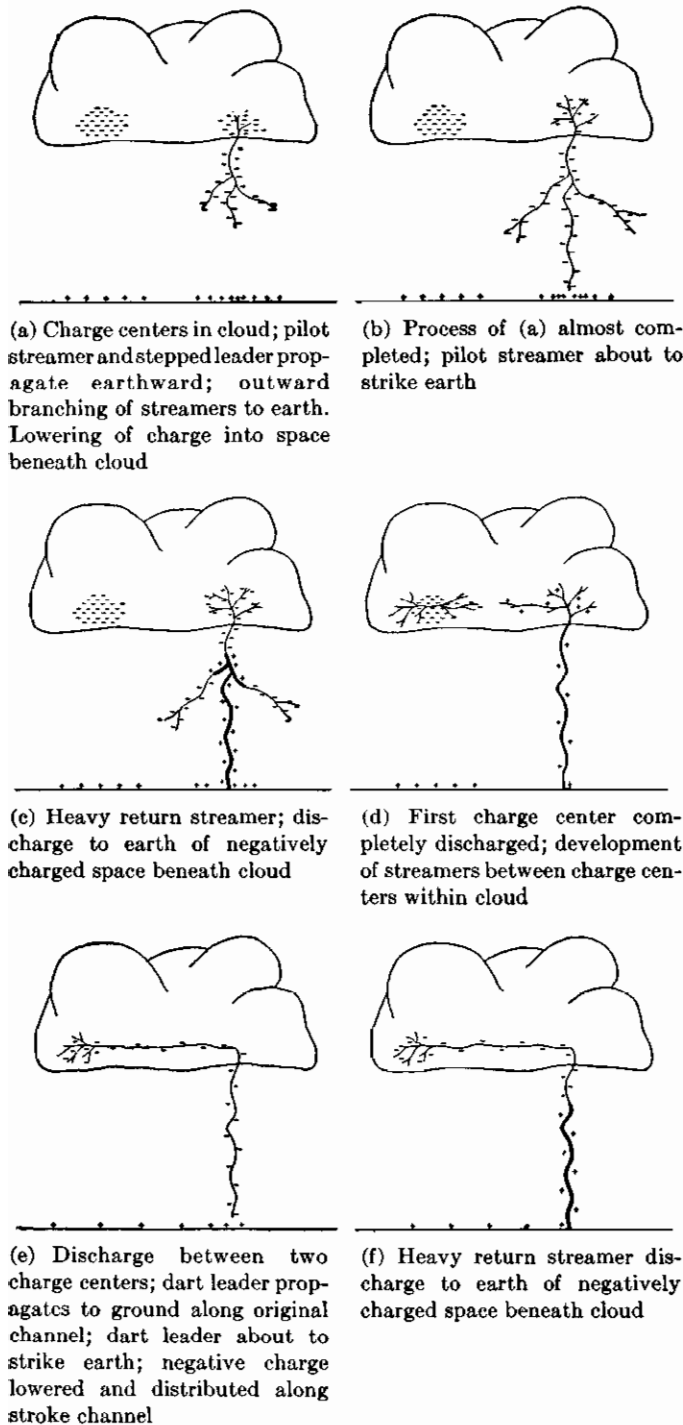

Fig. 11—Diagram showing charge distribution at various stages of lightning discharge.

conducting to accommodate these large currents. The charge that had been lowered from the cloud to the antenna-like system of streamers by this means is further lowered to ground. The former of these processes is relatively slow, requiring a time of the order of 10 000 microseconds, whereas the latter is relatively fast, requiring only about 50 to 100 microseconds. Since the same charge is involved in both stages, the difference in time explains the large difference in currents involved in the two stages.

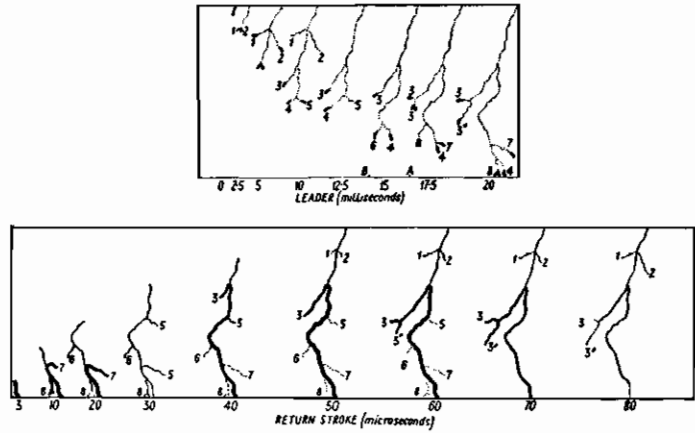

Fig. 12—Mechanism of discharge of component stroke, according to Schonland¹⁸.

Fig. 12 represents the story of a complete discharge of a component stroke according to Schonland,¹⁸ in which the upper figure shows the progress of the stepped leaders and the lower figure the return streamer. Note that the time scale has different units.

From the instant of initiation of the leader streamer to ground similar leaders progress into the cloud, tapping more and more charge. After the completion of the initial high-current discharge, a smaller current continues to flow for some time, the magnitude and duration being dependent upon the propagation of the streamers within the cloud body. This point is illustrated very well by the current record¹⁹ shown in Fig. 13 obtained at the Cathedral of

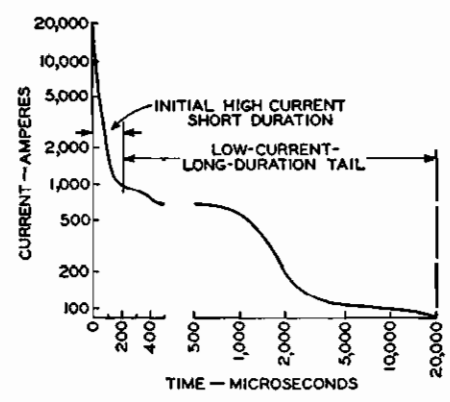

Fig. 13—Current record of direct stroke to Cathedral of Learning of the University of Pittsburgh, June 10, 1939; negative polarity; four coulombs.

Learning of the University of Pittsburgh. A high-current component, which rises very quickly to 20 000 amperes, decreases to 1000 amperes in 200 microseconds. From 1000 amperes the decay is much slower, the current dropping to less than 100 amperes in 10 000 microseconds.

Multiple Strokes—With the development of a high-conducting are path between the charge center and ground, the potential of the charge center is lowered considerably. This process may develop higher potential differences between this charge center and another charge center within the cloud, resulting in the continued progress of streamers

into the cloud and the formation and attraction of streamers from the other charge center. Upon the meeting of two such approaching streamers, a relatively low-conducting path to ground for the new charge center is formed. The resulting discharge traverses the same path blazed by the first stroke. The leader streamer of this stroke differs from that of the first stroke in that the stepped phenomenon is usually not discernible in Boys camera photographs, there is no branching, and the velocity of propagation is much larger, being of the order of three percent of that of light. Because of these characteristics this leader is known as a "dart" leader. Upon reaching the earth, a return streamer travels back to the cloud just as for the first stroke. This mechanism is illustrated in Fig. 11. The stroke current at the ground is also similar in character to that of the first stroke, rising rapidly from zero to a maximum, falling slowly for several hundred microseconds and then more slowly for a much longer time. Schonland's results indicate that in the majority of cases the crest magnitude of the first stroke is the greatest, probably because the branching of the antennae system of streamers permits of a lowering of a larger charge before it is released to earth. This is not always the case, as the second or subsequent strokes are sometimes the greatest.

As the charge in the second charge center is dissipated by being carried to ground, the streamer in the cloud might tap a third center and the same process be repeated. In general, approximately half the flashes are of this multiple character. Flashes having as many as 40 component strokes have been observed by Larsen.²⁰ A conception of the relative time involved in these processes is given by Fig. 14.

In general, the rates of propagation of the discharges discussed vary in inverse manner to the amount of previous ionization of the path. Thus, the initial pilot streamer progressing into virgin air with very little ionization was

the slowest, being about 1/20 of one percent of that of light. The stepped leaders that followed in the path blazed by the pilot streamer have a velocity of the order of 3 percent of that of light. The return streamer is also quite rapid as it follows the intense ionization of the initial streamer and has a velocity about 10 percent of that of light. Because of the interval elapsing between component strokes and the resultant deionization, the velocity of propagation of the dart leaders is about one per cent of that of light. The velocity of propagation of the pilot streamer into virgin air appears to be associated¹⁶ with the critical drift velocity of an electron under the influence of the breakdown voltage gradient of air.

Hot and Cold Lightning—It has been known for a long time that the explosive and incendiary effects of different strokes vary widely. One stroke might blow a tree apart and still have little burning tendency while another might have little bursting effect and still result in a fire. This difference was recognized as early as 23 A.D. by Pliny the Elder who wrote in his "Natural History":

"Of thunderbolts themselves several variations are reported. Those that come with a dry flash do not cause fire but an explosion. The smoky ones do not burn but blacken. There is a third sort called 'bright thunderbolts' of an extremely remarkable nature; this kind draws casks dry without damaging their lids and without leaving any other trace and melts gold and copper and silver in their bags without singeing the seal. Marcia, a lady of high station in Rome, was struck by lightning while pregnant and though the child was killed, she, herself, survived without being otherwise injured. Among the portents in connection with Catiline, a town councillor of Pompei named Marcus Herrenius was struck by lightning on a fine day."

Returning from antiquity, fire-tower lookouts have observed similar distinguishing characteristics in strokes that do and do not cause fires. Along more scientific lines the persistence of the luminosity of the main channel of a

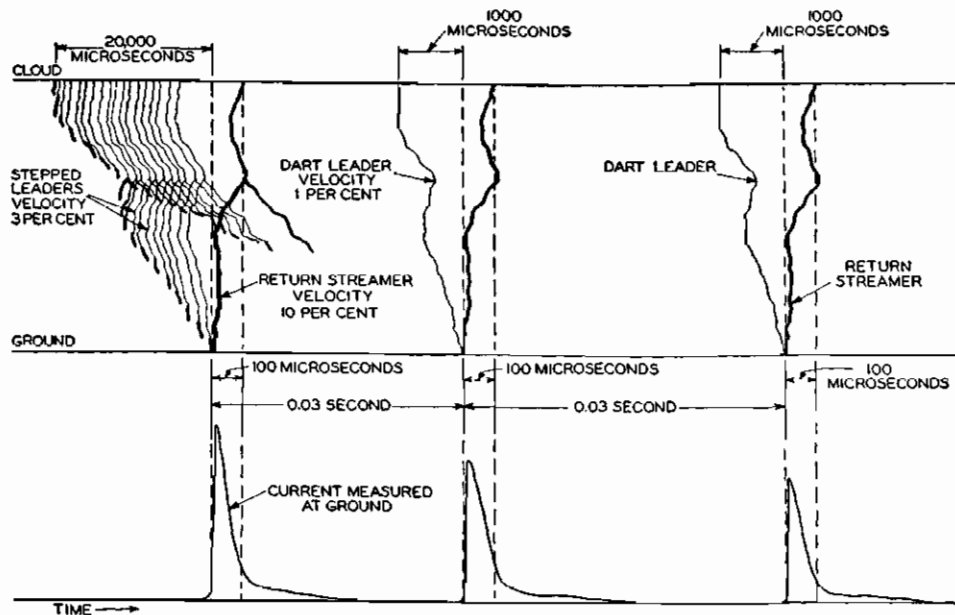

Fig. 14—Diagram showing lightning mechanism and ground current.

All velocities expressed in percent of the speed of light, which is 984 feet per microsecond or approximately 1000 feet per microsecond.

lightning stroke was recognized by Schonland and Collens¹³ in 1934.

Walter²¹ in 1935 discussed a photograph taken by Doctor H. H. Hoffert in 1889 which was obtained by turning the camera to and fro by hand about a vertical axis, the period of rotation being about three-quarters of a second. Streaks of light appeared between component strokes on the negative and in explaining their presence he says:

"Now, as I demonstrated some years ago, they are by no means due to an afterglow of the lightning channel produced by thermal or phosphorescent causes, but they are always associated with a real after-discharge in the channel, that is, with an electric current following the main discharge along the same track."

According to his explanation, the duration of these points of luminescence must have been at least 0.1 second.

Stekolnikov and Valeev²² in 1936 measured voltages induced on a horizontal antenna by indirect lightning strokes. Results they obtained with a rotating klydonograph indicated that the duration of the current was between the limits of 2600 and 10 000 microseconds.

McEachron and McMorris,²³ also in 1936, refer to an unpublished photograph by one of them which shows a duration of luminescence of 0.23 second. This stroke however is described as being to a tall steel-frame building and such a stroke has different characteristics from strokes to open ground and transmission lines.

Continuing the work of Schonland and his associates, Malan and Collens¹⁵ report data on the luminescence in the following statement:

"The most frequent value of the duration as measured on the photographs appears to be of the order of 1000 microseconds, ranging in extreme cases from a few hundred microseconds to half a second."

Bellaschi,²⁴ by comparing laboratory discharges of different magnitudes and durations, showed that long-duration currents were essential to ignite excelsior, form fulgurites, or produce significant melting of metal. Further evidence of the existence of lightning currents of long duration was observed by Bergvall and Beck²⁵ in the form of markings left by discharges upon lightning rods and arrester gaps. These markings were correlated in the laboratory with markings produced by impulses of known wave shape, from which the existence of long-duration waves was demonstrated. Fig. 15 shows the degree of melting of several one-half-inch copper rods tapered for a distance of one

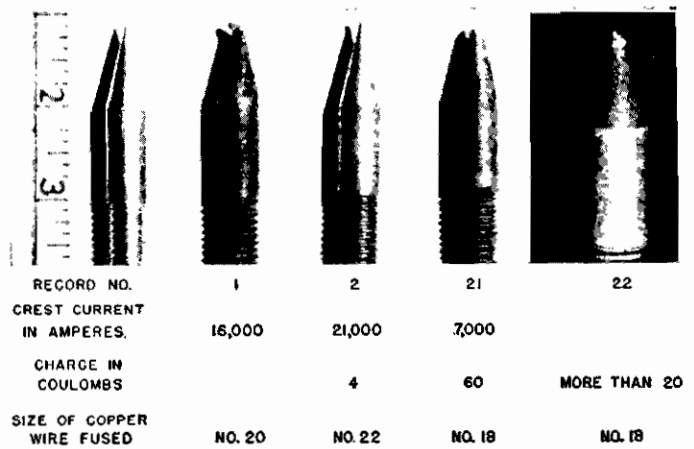

Fig. 15—Fusion data on strokes to the Cathedral of Learning, University of Pittsburgh.

inch, which were placed by the authors in the path of actual lightning currents. A fulchronograph record for one of these is shown in Fig. 13.

6. Ground Gradients

As stated previously, the fine-weather electrostatic gradient at the surface of the earth is positive and averages about one volt per centimeter. As a charged cloud passes over a particular spot this gradient at first rises because the positive charge in the upper portion of the cloud becomes effective first. As the cloud continues to approach, the gradient then decreases and finally becomes negative as the negative charge in the lower portion becomes effective. The magnitudes of field gradients directly beneath thunder clouds are from about 50 to 100 volts per centimeter before a discharge occurs.

As discharges occur, the nature of the electric field becomes more complicated. Appleton and Chapman²⁶ have obtained cathode-ray oscillograms of the change in gradient due to strokes at various distances and correlated them with the characteristic portions of the stroke mechanism. Schonland, Hodges, and Collens¹⁷ have co-ordinated Boys camera photographs with similar cathode-ray oscillograms of the change in gradient due to strokes at distances of several miles. These records were found to be of the two principal types illustrated in Fig. 16, 65 percent being of the type shown on the left and 35 percent of the type shown

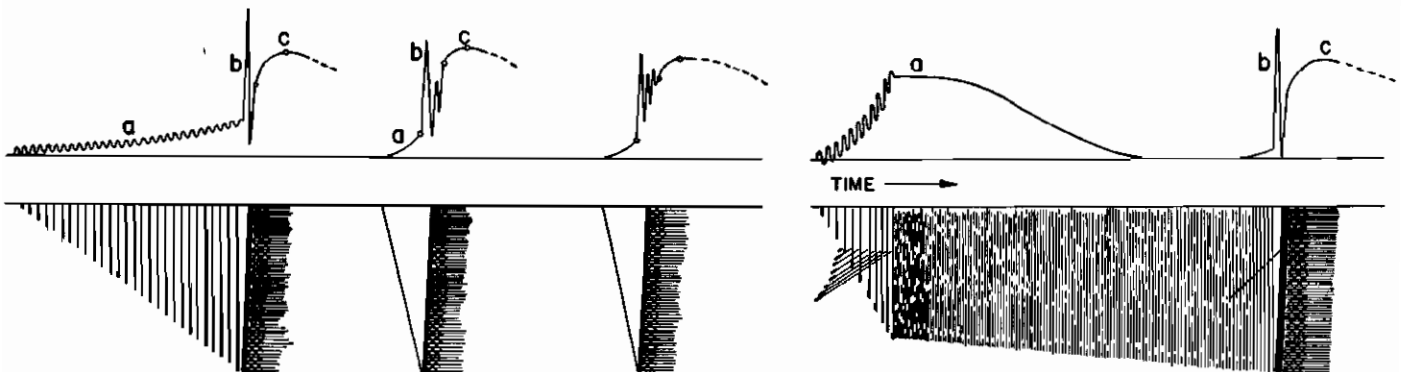

Fig. 16—Relation between stroke mechanism and ground gradients for the two types of discharges observed by Schonland.

on the right. In this figure the upper portions show the gradients and the lower portions the photographic records. As may be seen from this figure, the electric field can be resolved into three characteristic portions labeled *a*, *b*, and *c*. As shown by the photographic record, the "*a*" portion is associated with the downward leaders, the "*b*" portion is associated with the return streamer in the period it propagates from ground to cloud, and the "*c*" portion with the lower-magnitude current flowing down the channel after the return streamer reaches the cloud.

For the more predominant type of discharge illustrated on the left in Fig. 16, the pilot streamer moves from cloud to ground at a more or less uniform speed and the field increases as the pilot streamer propagates, having superimposed oscillations produced by the stepped leaders. The increase in gradient is produced by the lowering of charge from the charge center in the cloud to the region between cloud and ground. In the second type illustrated at the right, the pilot streamer moves at a uniform velocity of the same order of magnitude as for the first case over the first part of its path. However, at a certain point in the path its velocity decreases, and the step length and brightness of the stepped leaders becomes much smaller. Owing to the time constant of the amplifier used for measuring the field, the recording spot falls to zero during this phase of the leader process because of the slow change of field strength.

The "*b*" portion represents a much more rapid rate of change of field because of the rapid lowering of the charge from the antenna-like system between cloud and ground to the ground by the return streamer. Since rapid changes of current also are present, they produce part of the electric field. As the nature of the field is a function of the distance from the stroke, these records should not be taken as typical of the gradients very close to strokes.

7. Strokes to Tall Buildings

McEachron¹¹ has made investigations of lightning to the Empire State Building in New York City. Equipment installed in the tower can measure the current of strokes to the mooring mast, and cameras located in near-by buildings can photograph the stroke simultaneously, thus permitting co-ordination of the records. Because of the high altitude of this building, it acts much as a large needle extending up from a plane. The gradients developed at the tower become so large that most of the discharges develop from the tower mast and propagate upward. These discharges usually begin with small currents and may or may not develop into distinct discharges of high current value. Of 47 strokes photographed, 34 indicated continuous current flow until the end of the stroke and 4 consisted of two succeeding continuous discharges in the same path, while 7 others began as continuing strokes followed by distinct discharges. Development of extensive leaders from the ground end appears to be characteristic of strokes to tall buildings exclusively. Caution must be exercised in applying data obtained from tall structures to lower structures such as transmission lines, for certainly the pilot leader and stepped leader of the first component differ from those for strokes to essentially flat ground. In addition, the mechanism of discharge from tall objects may be such

as to draw strokes from clouds at a smaller voltage than lower objects.

II. INSTRUMENTS FOR THE MEASUREMENT OF LIGHTNING SURGES

Of primary importance in the lightning protection of transmission lines is a knowledge of the magnitude, duration, and wave shape of the voltage and current surges appearing on utility systems. The characteristics of the stroke itself determine the resulting surges which occur on the electrical systems. Thus it becomes desirable to have instruments capable of measuring not only the system voltages and currents, but also the properties of the stroke.

One difficulty encountered in the development of such instruments is the wide recording range both in magnitude and time that must be covered. Currents vary from a few amperes to 200 000 amperes. Portions of the wave change so rapidly that time intervals of the order of a microsecond need to be measured, while at the same time the duration of the complete stroke may be longer than one second, or 1 000 000 microseconds.

The element of chance is also introduced in that the point at which lightning may strike is unpredictable. The probability of a given point being struck is enhanced by height so that in some cases instruments are installed on tall objects. However, the available evidence indicates that discharges to such objects differ in important aspects from those to low objects. In order to obtain data that are truly characteristic of strokes to transmission lines and other electrical equipment, the observer is faced with the prospect of placing a large number of instruments in the field with the hope that some will obtain for him the desired information. Economic considerations thus place a very serious limitation upon the instruments, since to be practicable for use in large numbers their unit cost must be small.

Since voltage rather than current is the immediate cause of system outages it is natural that field measurements were first made of voltages produced on lines by lightning. Thus voltage-measuring instruments were developed first.

8. Spark Gaps

The first attempts were made with a relatively crude device consisting of parallel gaps with different spacings. To prevent the first gap to break down from short-circuiting the others and to prevent a system outage, a relatively high resistance was placed in series with each gap. The maximum gap broken down, which was indicated by markings on a thin piece of paper, was a measure of the voltage. Peek²⁷ used sphere gaps and needle gaps in parallel to obtain a measure of the wave shape. A comparison of the length of gap sparked over for the two types of electrodes gave some indication of wave shape.

9. The Klydonograph

The first successful field instrument developed for surge-voltage measurements was the klydonograph, invented by J. F. Peters²⁸ in 1924. In 1777, Doctor G. C. Lichtenberg discovered that figures can be produced in sulphur dust by the electrostatic field of a charged electrode placed near by. Others found that Lichtenberg figures could also be pro-

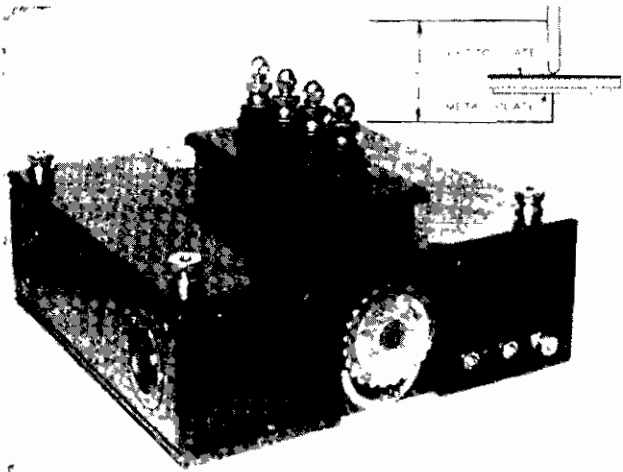

Fig. 17—Klydonograph.

duced on photographic plate. These figures are functions of the magnitude, polarity, and wave shape of the impressed voltage. The klydonograph (Fig. 17) employs these characteristics for the measurement of surge voltages.

The klydonograph consists of a rounded electrode bearing upon the emulsion side of a photographic film or plate resting on the smooth surface of an insulating plate backed by a plate electrode. In Fig. 18 are shown typical klydonograms obtained for different types of voltages. The minimum critical voltage necessary to produce a figure is about 2.0 kv and the maximum voltage that can be recorded is about 18 kv, since at higher voltages spark-over occurs and fogs the film.

For unipolarity there are characteristic differences between the figures for positive and negative voltages. However, for either polarity the radius of the figure, if it is symmetrical, or the greatest distance from the center of the figure to its outside edge, if it is unsymmetrical, is a function only of the applied voltage. Oscillatory waves produce superimposed figures for each part of the wave, enabling a distinction to be made between unidirectional and oscillatory voltages.

The klydonograph has been built with multiple elements for simultaneously recording several voltages on a transmission line. It has been developed also with a slowly moving roll film co-ordinated with a recording clock to enable more than one surge to be recorded together with its time of occurrence. In addition rapidly moving film has been used for measuring power-frequency voltages and lightning surges. A better interpretation of the character of the surge can be obtained from positive figures since for the same voltage they are more than twice the size of the negative figure, and the nature of the figure varies more with wave shape. Thus negative surges of less than twice normal line voltage cannot be recorded as they are obliterated by the positive part of the power-frequency record. To overcome this disadvantage, Foust³⁰ developed an instrument having two elements in parallel, one connected in the opposite polarity to the other so that a positive figure is always obtained. In applying the klydonograph to the measurement of voltages on transmission lines a capacitance potential divider is generally used.

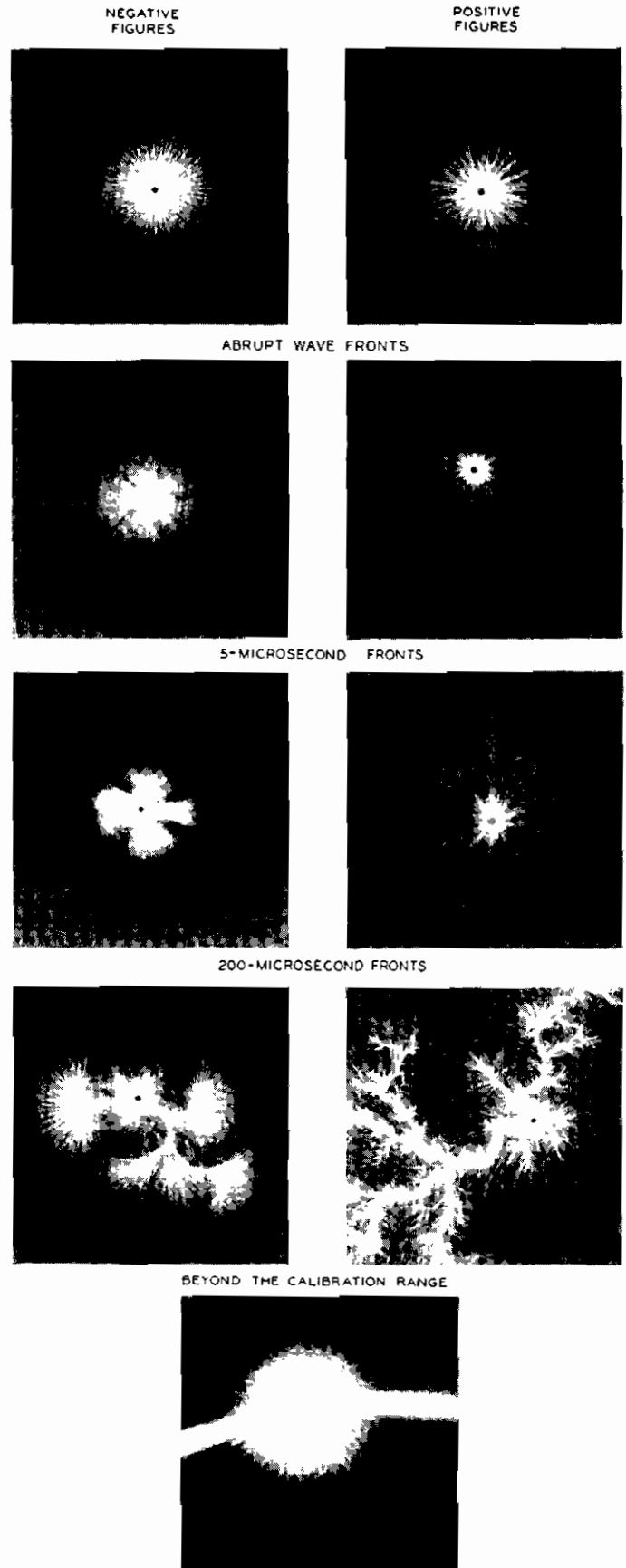

OSCILLATORY SURGE DUE TO AN ARCING GROUND

Fig. 18—Typical klydonograms.

The klydonograph has been employed in conjunction with a resistance shunt for the measurement of surge currents and has also been used to measure the maximum rate of rise of current in transmission-line conductors²⁹ and tower legs³¹ by connecting it across a resistance in series with a loop of wire inductively coupled with the main current circuit.

The klydonograph is a relatively simple and inexpensive device, which permits its use in large numbers. It has been valuable in providing statistical data on the magnitude, polarity, and frequency of voltage surges on transmission lines. However, its accuracy in measuring magnitude is only of the order of 25 or 50 percent and certain interpretations regarding wave shape that have been made with it are questionable.

10. The Cathode-Ray Oscillograph

A cathode beam consisting of a stream of electrons emitted from a "cold" cathode and accelerated in an electric field in an evacuated tube was first produced by F. Braun in 1897. Wiechert developed the concentrating coil for beam focusing and the principle of magnetic and electrostatic deflection. In 1913 Zenneck employed the principle of the cathode-ray beam to record electrical phenomena. He photographed traces of the beam impinging on a fluorescent screen and deflected by a surge of a few milliseconds duration. This method of recording, however, was not suitable for surges as fast as those produced by lightning. Dufour³² developed the first cathode-ray oscillograph capable of recording such transients. He increased the recording speed by permitting the beam to impinge directly upon photographic film placed inside the evacuated tube. An oscillograph of this type was first used to study the behavior of artificial lightning surges on a transmission line in the United States by the Westinghouse Electric Corporation in 1926, on a five-mile line furnished by the Duquesne Light Company.

Unless the beam is prevented from striking the film until the occurrence of the phenomenon which it is desired to record, fogging of the film results. Norinder³³ overcame this difficulty by means of a special relay, which normally prevented the beam from striking the film but which upon the occurrence of a surge bent the beam around the blocking target. The Westinghouse company³⁴ employing this relay developed an oscillograph suitable for both field and laboratory work.

Two other schemes have been used to initiate a Dufour type of oscillograph and make it suitable for lightning studies. The General Electric Company³⁵ developed an oscillograph in which the voltage supply to the cathode was an impulse, from a small surge generator, initiated through a triple gap by the surge to be recorded. George³⁶ developed a hot-cathode grid-controlled high-vacuum tube.

Oscillographs of the foregoing type employ cathode voltages of about 30 to 40 kv. Having power supplies of such high voltage and being of the pumped type to enable removal of film, they are relatively expensive and delicate in operation and require the constant attendance of an operator. These considerations greatly limit their use in the field, especially in numbers sufficient to obtain data of a statistical nature.

The Radio Corporation of America has developed a sealed-off cathode-ray oscillograph tube that permits sufficient recording speed by means of external photography of the fluorescent screen. Sufficient writing speeds by this method were made possible by its great beam intensity and the development of more sensitive photographic films and faster lenses. A laboratory oscillograph utilizing this tube has been described by Kuehni and Ramo.³⁷ Being sealed off, this tube lends itself readily to field work, for automatic operation. Wagner and McCann³⁸ with the cooperation of Ackermann developed a circuit and auxiliary device for use with this tube that permits its placement in the field without the constant attendance of an operator. It is portable and operates from a 110-volt a-c circuit. The tube is of the hot-cathode type and requires a potential of 15 000 volts to accelerate the electron beam which impinges upon a Willamite screen. The image thus produced is photographed. An auxiliary grid within the tube prevents the formation of an electron beam under normal conditions; hence fogging of the film is prevented. On the occurrence of a surge the beam is automatically initiated by the control grid and records the phenomenon.

To measure the voltages on transmission lines a capacitance divider is generally used, and for surge currents a resistance shunt, the voltage across the resistance being applied to the oscillograph plates. To cover a wider current range a nonlinear shunt can be used.

11. Paper Gaps

A thin piece of paper between two electrodes connected in the lead carrying the surge current has been used to obtain an indication of the magnitude of surge currents.^{39, 40, 41} Tests with surge-generator discharges and 60-cycle currents indicate that the area of the hole produced in the paper is proportional to crest magnitude of current and is independent of wave shape. The effect of a multiple stroke, however, is questionable.

12. Fusible Wires

By calibrating different-sized wires connected in series and noting the largest one that fuses,⁴² it is possible to obtain an approximate indication of the time integral of the square of the current. One of the first to employ this principle was Professor E. C. Starr of Oregon State University, who used it to measure strokes to masts at lightning stations which he established on mountain peaks.

13. Magnetic Surge-Crest Ammeter

The magnetic surge-crest ammeter developed by Foust and Kuehni⁴³ provided a simple and inexpensive instrument capable of measuring the crest magnitude and polarity of surge currents. This instrument consists of a small bundle of laminated permanent-magnet steel pieces. It is placed in an unmagnetized condition in the vicinity of a conductor whose current it is desired to measure. The remanent magnetism produced in the steel is a function of the magnitude of the current producing it for unidirectional surges. A special instrument measures the remanent magnetism and is calibrated directly in terms of the original magnetizing current. The polarity of the surge is indicated by the direction of magnetization. This instru-

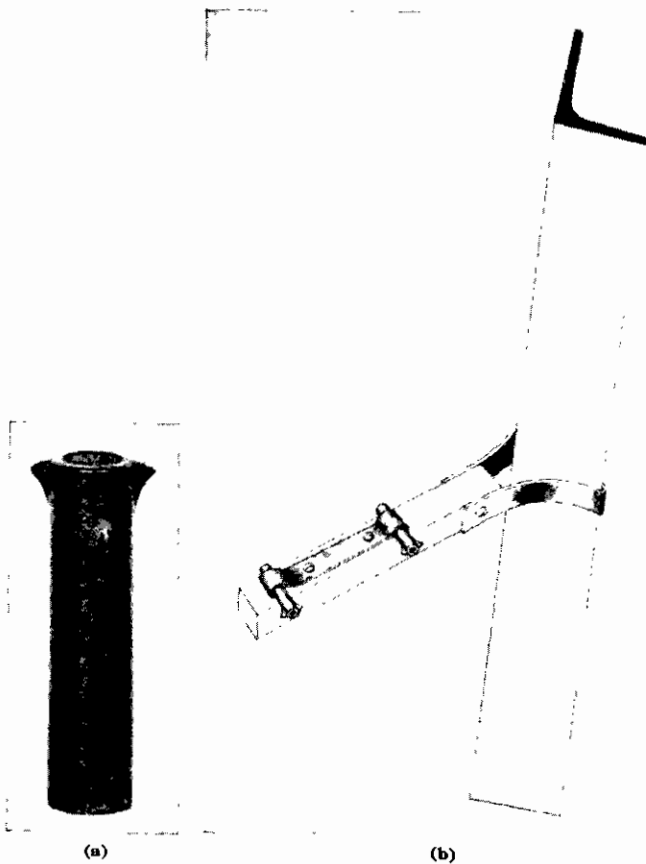

Fig. 19—Surge-crest ammeter links.

(a) Link.

(b) Link in position on transmission-line tower.

ment has been used extensively both in the United States and abroad to measure currents in direct strokes; in transmission-line tower legs, ground wires, and phase conductors, in counterpoise conductors and in ground leads of arresters.

The magnetic links are usually placed in brackets as shown in Fig. 19 (b), fastened to the conductor so that their axes coincide with the normal direction of the magnetic lines of force. Several links placed at different distances from the conductor commonly are used to cover a wider range of currents and also to distinguish between unipolarity and oscillatory surges. These instruments being cheap and simple, thousands of them have been used throughout the United States and have provided valuable information relating to lightning currents.

14. Crater-Lamp Oscillograph

A magnetic oscillograph cannot record faithfully frequencies much above 10 000 cycles per second and cannot record the wave shape or crest magnitude of the initial high-current components of lightning surges. However, it should be able to record the relatively long low-current component and give some information on the total duration and number of components of strokes. Ordinary methods of automatic operation by mechanical relays require about one-half cycle to initiate. However, the crater-lamp oscillograph⁴⁴ overcomes this difficulty. It uses

a light source consisting of a neon crater lamp, which can be initiated by the transient in about 20 microseconds.

15. Fulchronograph

The cathode-ray oscillograph is the best instrument available from the standpoint of determining wave shape of transients, such as lightning surges. Its cost and complexity, however, limit its use in the field. Because of the variable character of lightning, it is important to obtain sufficient data to determine the statistical nature of its properties. The klydonograph and surge-crest ammeter have provided data of this type on the magnitude and polarity of surge voltages and currents. The number of components, wave shape, and duration of surges are of even more importance, however, and it was with the view of gathering data on these properties of surges that the Westinghouse Electric Corporation³⁸ developed a number of new recording instruments. The most important of these is the fulchronograph,* a device capable of measuring the wave shape and duration of the tail of current surges, but cheap enough, and simple enough in its operation to be used in large quantities in the field.

The essential part of the fulchronograph is a slotted aluminum rotating wheel. In a "high-speed" fulchronograph, Fig. 20(a), the wheel turns at 3450 rpm, and in the "slow-speed," at approximately 60 rpm. In the rim of each are 408 laminations of permanent-magnet steel nine mils thick, projecting from each side. The laminations pass between narrow coils, Fig. 20(b), through which flows the current to be measured. As a particular set of laminations spans the gap between the coils, they are subjected to a radial magnetizing force proportional to the current at that instant. By measuring the retentivity or residual flux in the laminations it is possible to reconstruct a graph of the current as a function of time. The device functions in a manner similar to the surge-crest ammeter except that time has been introduced by the rotation of the wheel.

By placing a high-speed and a low-speed fulchronograph together in series and running them continuously, greater wave detail and a longer period of time can be covered than by the use of either one separately. The high-speed unit in one revolution divides 17 000 microseconds into 43-microsecond intervals, the low-speed unit in one revolution divides one second into 1/400 second intervals. Multiple-stroke discharges rarely last longer than one second, or have time intervals between strokes of more than 0.5 second. These facts make it possible with the data provided by the two wheels to resolve a surge into its multiple components and to obtain the wave shape and magnitude of each.

16. Magnetic Surge-Front Recorder

The principal disadvantage of the fulchronograph is its inability to measure the high rates of rise of the front of the waves. Devices for measuring the maximum rate of rise have been available for some time. As mentioned previously, the klydonograph can be used to indicate the maximum rate of rise on the front of lightning-current surges. Probably of greater importance than the maxi-

*This name was obtained as a combination of the Latin word *fulmen*, meaning lightning, and the Greek word *chronos*, meaning time, and *graphein*, meaning to write.

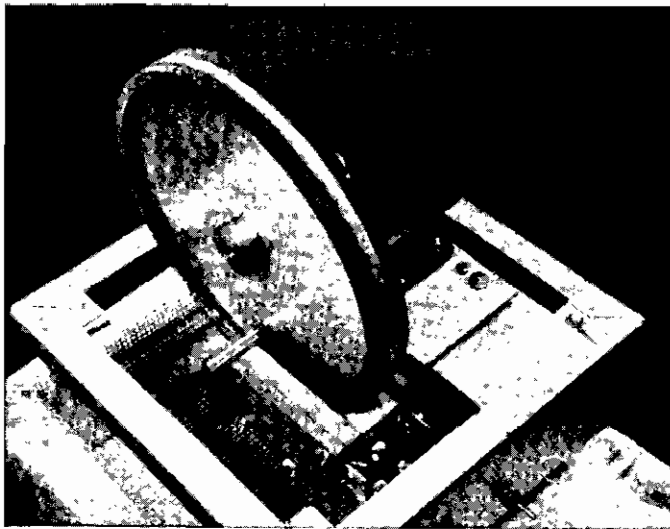

(a)

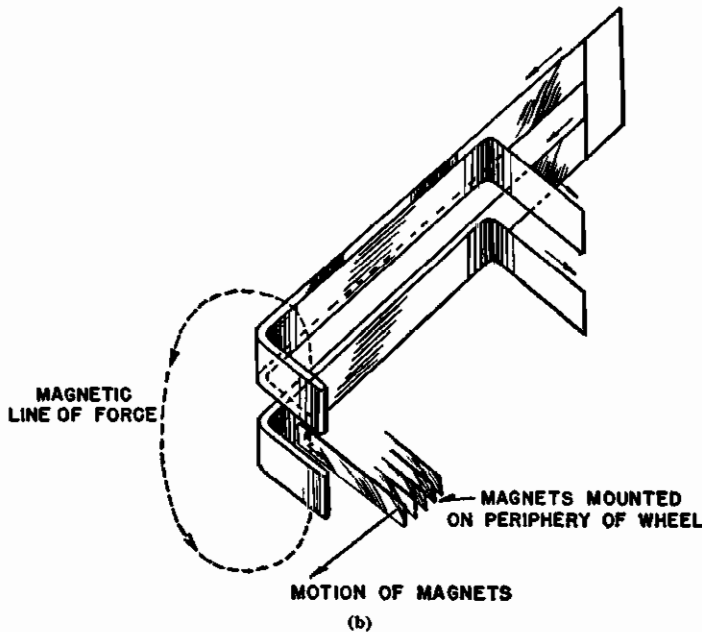

(b)

Fig. 20—Fulchronograph.

- (a) High-speed fulchronograph showing wheel.
- (b) Diagram of fulchronograph showing relation between one set of laminations and the coils on one side of the wheel. The other side of the wheel is the same, except that the magnetic circuit is partially completed through iron.

imum rate of rise is the average rate of rise, such as can be defined by a straight line drawn through the two points which are 10 percent and 90 percent of crest value.

The magnetic surge-front recorder which, with a schematic diagram, is shown in Fig. 21 is a device for recording this property of lightning currents. It consists of three circuits containing resistance and inductance having different time constants. They are connected across an inductance carrying the main surge current or a loop inductively coupled with the circuit carrying the main surge current. Magnetic links placed within the field of the

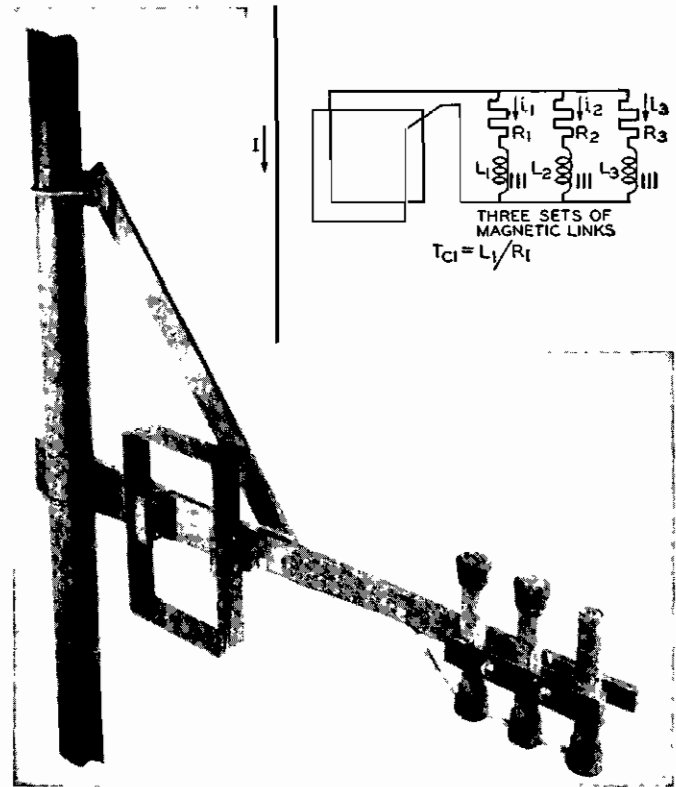

Fig. 21—Magnetic surge-front recorder.

inductors of these three circuits serve to record their maximum currents i_{max} . The introduction of an appreciable time constant T_c into these circuits prevents the currents in them from responding to instantaneous changes in the main current, thus substantially eliminating the effect of high-frequency oscillations in the front of the wave. If the resistors were not present, the current in the auxiliary coils at all times would be proportional to the rate of change of the main surge current and the maximum current in them would be proportional to the maximum rate of rise of current on the front of the main surge.

When inductance is added to the auxiliary circuits, the maximum current in any one of them is proportional to the average rate of rise of the main surge current over a definite range. Three of these circuits are adequate to cover the desired range of time to reach crest.

17. Magnetic Surge Integrator

The magnetic surge integrator is a relatively simple and inexpensive device for recording the total charge or the integral of the current in a lightning surge. It consists essentially, as shown by the schematic diagram of Fig. 22 (a), of a noninductive shunt that carries the main surge current, and across which an inductor is connected. Neglecting the resistance of the inductor, its current at any instant is equal to the time integral of the main surge current, and, if the surge is nonoscillatory, the final maximum value of this current is the total integral of the main surge current. To cover a wide range, three magnetic links are placed at different points within the magnetic field

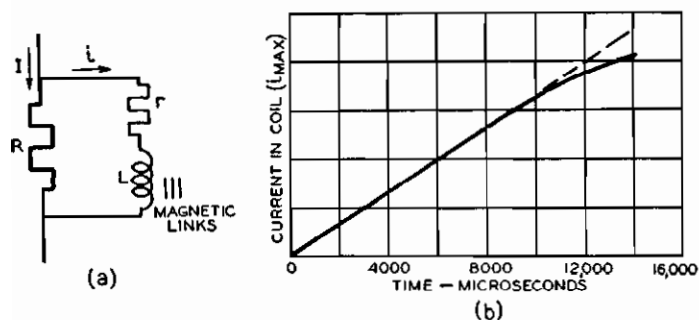
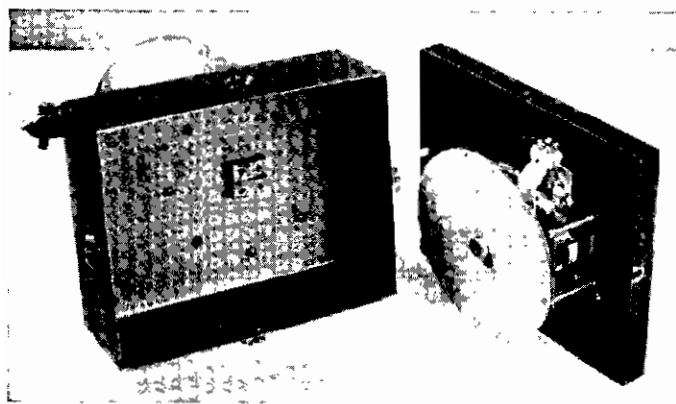

Fig. 22—Magnetic surge integrator.

- (a) Schematic diagram.
(b) Response curve.

produced by the coil. The magnetic field that magnetizes the links is a function of the coil current. Thus from a measurement of the remanent magnetism in the links a record of the total charge in the surge is obtained. The effect of the resistance of the coil is to limit the time for which the response is an accurate measure of the integral of surge current. If two coils having different time constants are used it is possible, in addition to measuring the charge, to form some idea of the wave shape. The two time constants are adjusted so that one coil can measure accurately up to 10 000 microseconds (Fig. 22 (b)) and the other up to 300 microseconds. This type of integrator forms with the magnetic surge-front recorder and surge-crest ammeter, a good, inexpensive combination, especially where power is not available.



(a)

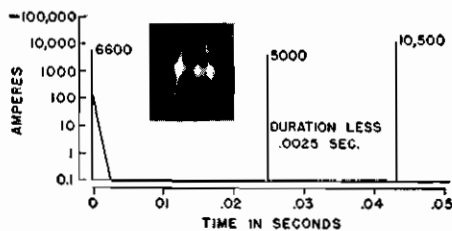

(b)

Fig. 23—Photographic surge-current recorder.

- (a) Surge-current recorder with cover removed.
(b) Typical record.

18. Photographic Surge-Current Recorder

The photographic surge-current recorder⁸⁵ is an instrument which has been developed to record the multiple character of strokes and the continuing currents of very low magnitude (below the 50-ampere sensitivity limit of the fulchronograph). The instrument is shown in Fig. 23 with a typical record. It employs the principle of photographing the luminosity produced by flow of the surge current across a short gap. The film image is produced through a special aperture and set of barriers so constructed that the light from the gap spreads in a non-uniform manner over the film perpendicular to its direction of motion. The barriers confine the image to a narrow wedge in the direction of film motion to enable high resolving power with time. The width and density of the image provide a measure of current magnitude. As current is increased, the film density is saturated at increasing distances from the center axis (See Fig. 23). However, at a point just beyond this region, the film density can be measured, which together with distance from the axis determines the current magnitude. Current can be measured to an accuracy of about two to one, but over the very great range of 0.1 to 150 000 amperes. The resolving power with time for the instrument is 600 microseconds. The film rotates one revolution per second; thus, time intervals between separate components can be measured for strokes having total durations up to one second.

III. FIELD STUDIES

From the standpoint of the lightning performance of electrical systems the frequency of occurrence, as well as the magnitude and wave shape of the voltages and currents produced on systems, is important.

19. Frequency of Thunderstorms

Isokeraunic charts have been published showing the frequency of occurrence of thunderstorms throughout the United States. The total number of storm days (days on which thunder could be heard) to be expected each year in different parts of the country is shown in Fig. 24. The average number of storm days recorded each month over a 40-year period is given in Fig. 25. The data for these charts for storms in the United States were obtained for a period from 1904 to 1943 by the United States Weather Bureau.⁹² The storm days in Canada (Fig. 24) are based on isokeraunic charts published by W. H. Alexander.⁴⁵

Examination of the yearly chart shows an average number of about 40 storm days per year for all of the United States east of the Rocky Mountains. There are two pronounced centers of activity, the greatest in Florida, with more than 90 storm days, the other in New Mexico with a maximum of about 60. The number of storms in the Pacific Coast area is considerably lower, averaging from 3 to 10.

The month of least storms in the United States is December, with the center of thunderstorm activity over Louisiana and with some activity in the Gulf and South Atlantic states. For each succeeding month the storm activity increases throughout the country, spreading rapidly in the southeastern states and reaching a peak for

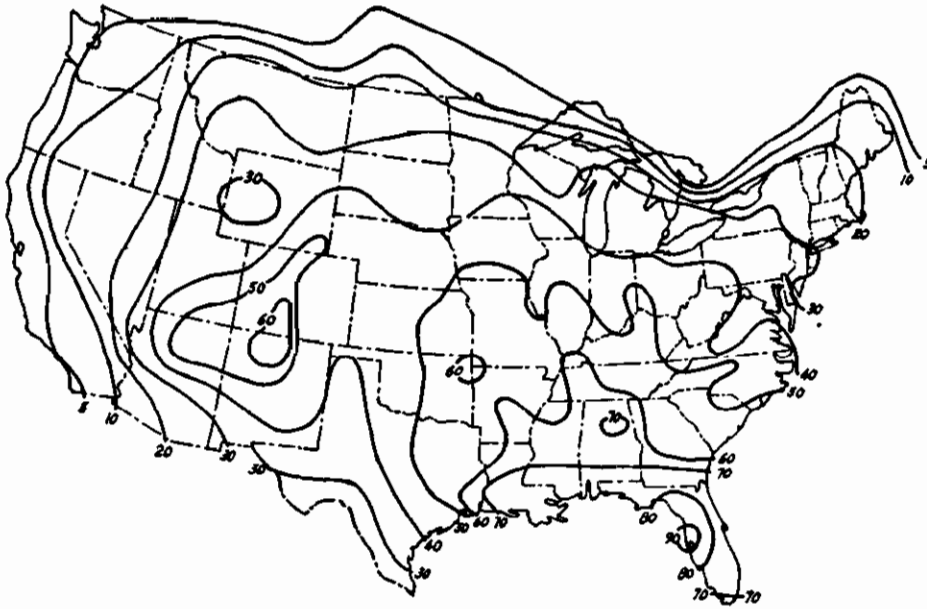

Fig. 24—Annual isokeraunic map showing the number of thunderstorm days per year.

most of the country in July, when the number of storms per month for all but the Pacific Coast area has reached an average of about 9 storm days with a maximum of about 20 in South Florida and 18 in New Mexico. By August the number of storm days has started to decrease and in September it is rapidly decreasing. In the Pacific Coast region the activity is more nearly constant, but has a slight peak in July.

Although these charts do not give an indication of the intensity, duration, extent, or number of storms occurring, they constitute the best data available. Also, a comparison of the data obtained by several investigations on the seasonal variation of the number of lightning disturbances produced on power systems in a given region with the number of storm days indicates fairly close agreement. That is, the relative number of system disturbances recorded per month varies with the months in practically the same manner as the number of storm days per month. An example of this is shown in Fig. 26 for data on distribution-arrester discharge currents.⁴⁶ However, the number of such disturbances varies widely from year to year and for systems in different regions, even though the isokeraunic levels of the regions are nearly the same. There are several reasons for this. The number of surges reaching arresters,



Fig. 26—Comparison between variance of disturbances on systems (solid curve) and monthly isokeraunic levels; McEachron and McMorris⁴⁶.

transformers, and the like, of course, should depend to a great extent upon their density of installation and on the degree of shielding of the lines.

There are also other important reasons. Both local topographical and meteorological conditions appear to cause large localized variations in storm densities. In mountainous regions thunderstorms are generally of the heat or mountain type. Their formation depends on local meteorological and topographical conditions. Thunderstorms of the cold-front and warm-front types depend for their formation on the interaction of adjacent cold and warm air masses, which frequently cover hundreds of square miles. Their formation thus does not depend wholly on local topographical conditions. However, storms of this type, which are common to the East and Middle West, appear to follow more or less defined paths that do depend upon topographical conditions. Storms of this type sometimes follow rivers and valleys.

For such reasons the number of lightning disturbances on any one system depends upon its location relative to local topographical conditions and prevailing storm paths. Thus, it is rather difficult to establish from data obtained on a limited number of systems mean figures for the number of electrical disturbances to be expected. The best available method seems to be to base such data on the isokeraunic levels and to give as many data as possible on the range of variance that these localized conditions might introduce. The isokeraunic level of 30 storms per year is commonly used for this basis. When considering data regarding the number of strokes to transmission lines or the number of surges produced on transmission lines, one is interested in the number per unit length per unit time. The common basis used here is the number per hundred miles of transmission line per year. However, for considering the lightning performance of such equipment as arresters and transformers, the number of disturbances should be based upon the number occurring per unit of



Fig. 25— Monthly isokeraunic maps showing the average number of thunderstorm days occurring each month over the 40-year period from 1904 to 1943.

apparatus per unit time. In this discussion, surges in arresters or transformers are based on the number per single-phase unit per year.

20. Surge-Voltage Measurements on Transmission Lines with the Klydonograph

The first important field studies of surge voltages on transmission lines were begun in 1925⁴⁷ with 26 three-terminal klydonographs installed on 27 systems varying in voltage from 6.6 to 220 kv. Subsequently, other studies were begun in the United States.⁴⁸⁻⁵² Investigations also have been made in South Africa and Japan.⁵³ At the time these studies were started it was thought that induced voltages resulting from strokes in the vicinity of a transmission line were the primary cause of system flashover.

In Figs. 27 to 30 are shown percentage distribution curves of the magnitude of lightning surges obtained from these studies. These curves give data on voltages that might be expected at a given point on a line caused by surges originating at different points along the line. The voltage is, of course, a function of the insulation level and the wave shape of the surge. The maximum voltage that has been recorded was 5 000 000 volts and was obtained by

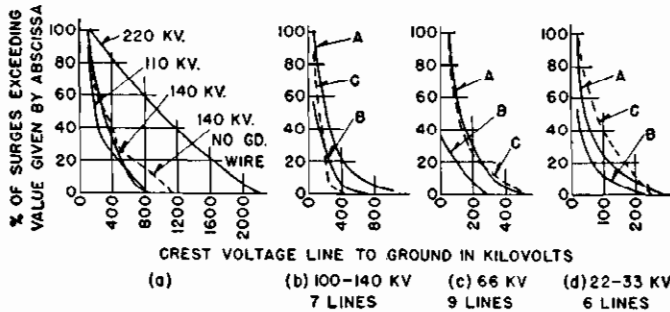

Fig. 27—Klydonograph records of voltages produced by lightning⁴⁷⁻⁵² on transmission lines of various voltage ratings, both with and without ground wires.

Curves A apply to total lightning surges on lines without ground wires. Curves B apply to surges not producing outages on lines without ground wires. Curves C apply to total lightning surges on lines with ground wires.

Pittman and Torok⁵⁴ with a cathode-ray oscillograph from a direct stroke to a conductor of a 110-kv wood-pole line without ground wires. Examination of Figs. 27(a)-(d) shows that the voltage decreases with the voltage rating of the line. This probably results primarily from the reduction of insulation strength with reduction of operating voltage. The klydonograph studies indicated that most surges on lines were unidirectional and of positive polarity.

The data in Sec. 27 relating to the currents in lightning strokes indicate that about 90 percent of all strokes to ground lower negative charge to earth. Such negative strokes produce negative voltages on a transmission line if they strike the line directly but induce positive surges if they strike in the vicinity of the line. In spite of the predominance of the recorded positive voltages, it does not follow that the surges produced on the line at the point of origin are predominantly positive. The recording characteristics of the klydonograph and the attenuation

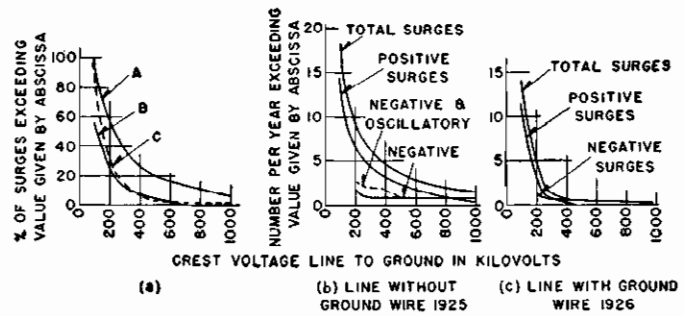

Fig. 28—Klydonograph records of voltages produced by lightning on a particular 120-kv 148-mile line⁴⁷ before and after installation of a ground wire. Ordinates in (b) and (c) give numbers at a three-phase station. Curves A, B, and C are defined in Fig. 27.

characteristics of the surges probably affect the conclusions. Most of the available data on polarity were obtained with the normal-type klydonograph having but one element for each voltage measurement. For positive polarity the lower range of sensitivity is slightly above the normal crest line-to-ground operating voltage. But for negative polarity the lower range of sensitivity is two or three times this magnitude. Thus negative surges of low magnitude were not recorded. Most direct strokes to lines without ground wires produce flashover resulting in chopped and sometimes oscillatory waves. Short-tail waves are attenuated much more rapidly than long-tail waves. Available data indicate that negative waves of this type are attenuated to voltages below the recording range of the klydonograph in 4 or 5 miles. Positive surges of longer duration, however, may propagate 15 or 20 miles before decreasing below the recording range of the klydonograph. Therefore the distance from which positive surges can originate and still be recorded is three or four times as great as for negative surges. Consequently the number of positive surges recorded should be proportional.

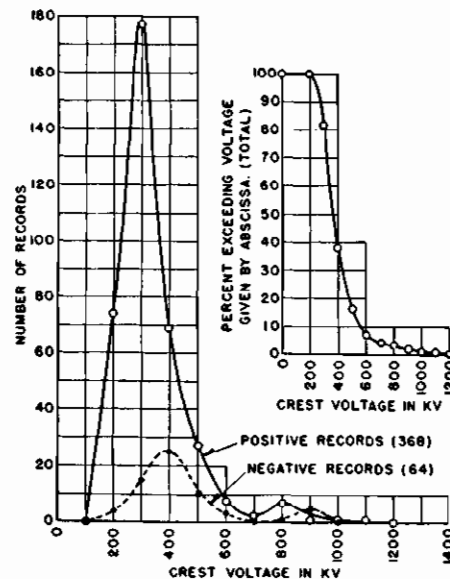

Fig. 29—Amplitude and frequency of surge voltages measured by Rokkaku on the Inawashiro lines in Japan⁵⁵.

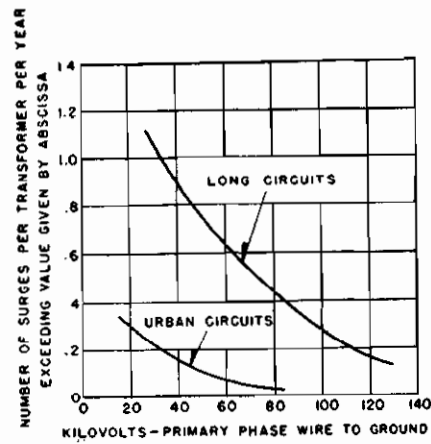
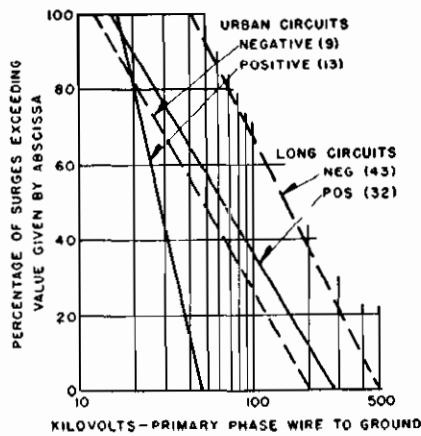

Fig. 30—Lightning surge voltages recorded by Halperin and McEachron⁵⁷ on 4-kv overhead circuits of the Commonwealth Edison Company.

Another factor that may color the results drawn from data of this type is that sometimes switching surges resulting from the lightning disturbance were recorded instead of the actual lightning surge voltage. However, all switching surges that were known to be such are excluded from the data.

21. Frequency of Occurrence of Lightning Surge Voltages

The number of lightning surges recorded at any one three-phase klydonograph station per year in the studies conducted in the eastern part of the United States varied from 15 to about 100 for lines rated from 33 to 220 kv. These lines were situated in regions having annual isokeraunic levels from 25 to 40. The instrument stations were located at the ends of lines, and since surges originating at distances in excess of 20 miles are attenuated below the recording range of the klydonograph the foregoing data result in estimates of from 75 to 500 surges per 100 miles of line per year. As shown in Sec. 28 by studies with magnetic links,⁵⁶ the number of direct strokes to be expected to lines in this class in regions of this isokeraunic level is from 50 to 250 per 100 miles of line per year, with an average of about 100. Thus the klydonograph data indicate that approximately half of the significant surges are produced by direct strokes. Since those strokes that induce voltages are about equal to those that strike the line, and since the line attracts strokes only from within a narrow band adjacent to it, then those indirect strokes that produce surges must strike the ground close to the line. This has been verified⁵⁶ by a stroke observed to have struck ground 200 feet from a transmission line of the Public Service Company of New Jersey and 1600 feet from a lightning-recording station on the line. No surge voltage was recorded in this case, although klydonographs and a cathode-ray oscillograph were in operation at the time to record voltages on the phase wires.

In general, induced voltages, since they seldom exceed 500 kv, rarely produce outages on 66-kv or higher-voltage lines. As the operating voltage of the line decreases the insulation also decreases and induced voltages may produce outages.

In Fig. 29 are shown data obtained in Japan⁵⁸ on a 154-kv line. Because of the lower limit of sensitivity of

the instruments and the variance of this with polarity, it is likely that the data below the first peaks for both polarities are questionable.

Fig. 30 shows curves of voltages obtained on both rural and urban 4-kv circuits of the Commonwealth Edison Company.⁵⁷ These curves indicate that voltages over about 200 kv seldom occur on urban circuits which are much

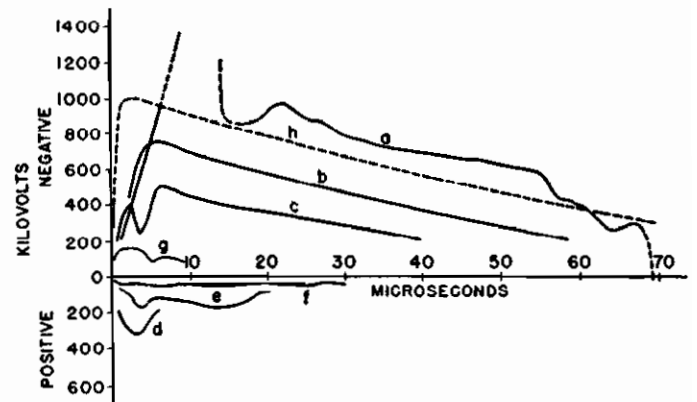

Surge No.	Polarity	Rate of Rise, Kv Per μ sec	Crest Kv	Time		Where Taken
				To Crest, μ sec	To $\frac{1}{2}$ Max. Voltage μ sec	
a	Neg.	143	Unknown; 1000 recorded	7 μ sec to 1000 kv	N. J.
b	Neg.	183	750	5	33	Tenn.
c	Neg.	270	550	6	26	N. J.
d	Pos.	137	325	3	4	N. J.
e	Pos.	30	180	5	15	W. Va.
f	Pos.	45	30	N. J.
g	Neg.	167	160	2.5	8	W. Va.
h	Pos.	500	1000	2	43	Trafford*

*Trafford Laboratory Test.

Fig. 31—Typical lightning surges recorded with cathode-ray oscillographs⁵⁸.

better shielded than the rural circuits where the upper limit of voltages appears to be about 500 kv. Curves also are plotted in this figure showing the probability of surge voltages of different magnitudes reaching transformers.

22. Surge-Voltage Measurements on Transmission Lines with the Cathode-Ray Oscillograph

Studies with the cathode-ray oscillograph of voltages produced on transmission lines were begun in 1928. The

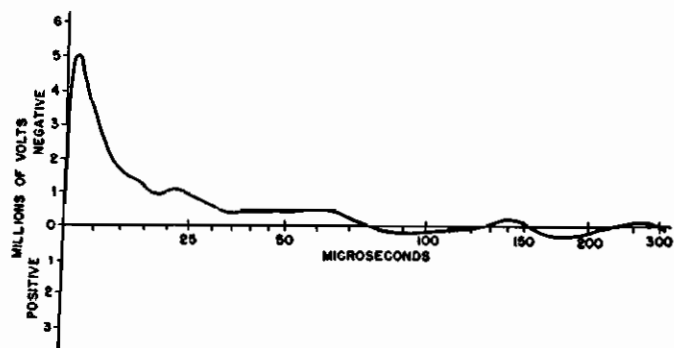

Fig. 32—Cathode-ray oscillogram of highest voltage recorded on a transmission line;⁵⁴ 110-kv wood-pole line of Arkansas Power and Light Company; no ground wire.

relatively few oscillograph stations that could be established did not permit of obtaining many records. In addition, interpretation of the records was difficult because of the influence of such unknown factors as propagation, distortion, and reflection. However, some valuable qualitative and quantitative information has been obtained from these studies. Some of the more important oscillograms are shown in Figs. 31 to 37.

In Fig. 31 are seven oscillograms obtained in the Westinghouse studies.⁵⁸ All were obtained on steel-pole lines, most of which had ground wires, and the surges originated at appreciable distances from the recording equipment. They indicate fronts of from two to seven microseconds and rates of voltage rise as high as 270 kv per microsecond. For comparison, an approximate standard $1\frac{1}{2} \times 40$ test wave is also plotted. The surges of larger magnitude have tails conforming closely to that of the standard wave.

The surge of highest voltage recorded on a transmission line is shown in Fig. 32. It occurred on a 110-kv wood-pole line without ground wires of the Arkansas Power and Light

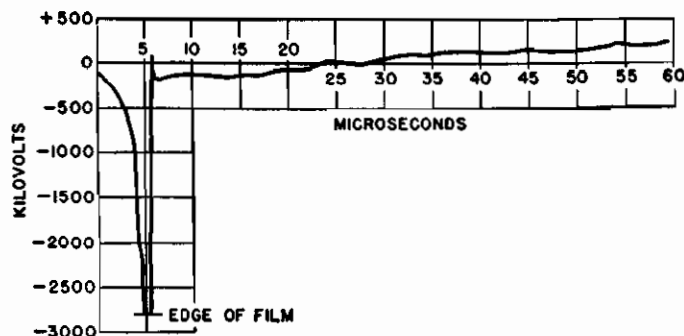

Fig. 33—Oscillogram of lightning surge voltage measured at point of origin⁶⁰.

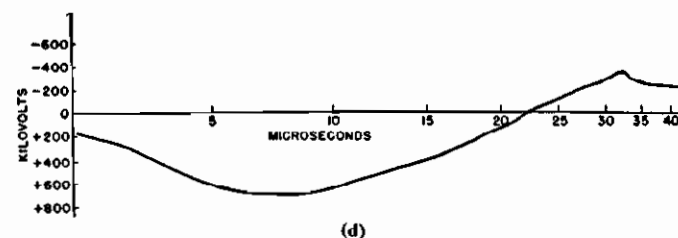
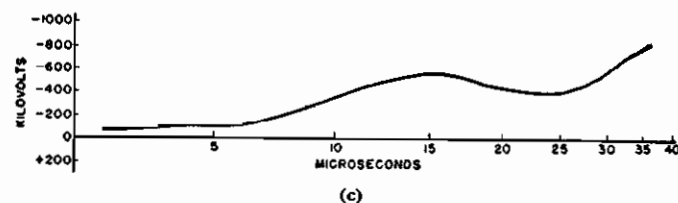
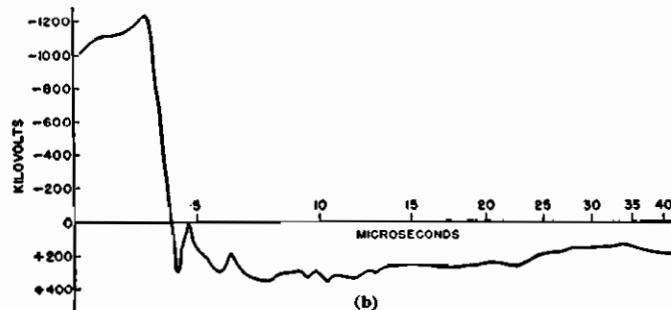
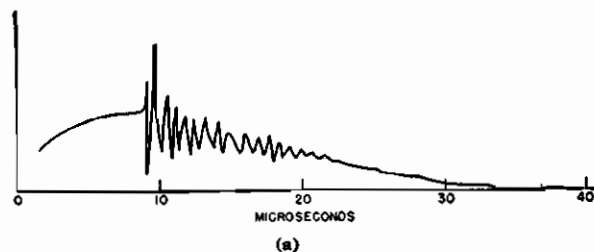

Fig. 34—Group of cathode-ray oscillograms of line voltage taken on the Wallenpaupack line⁶⁰.

- First cathode-ray oscillogram of a lightning surge on a transmission line. The oscillations were caused by flashover on an adjacent phase.
- Dead-end protective gaps flashed over on all three phases, causing a sharp change in voltage from 1260 kv negative to 310 kv positive in one microsecond. Flashover took place on front of wave.
- Record obtained while line was not energized. Voltage was still rising at the end of 36 microseconds and was then suddenly reduced to zero. Subsequent examination of the line indicated a flashover 23 miles away, which appeared to correlate with this oscillogram.
- The slightly oscillatory nature of this oscillogram is typical of a large group of waves. A cloud-to-ground stroke, at least ten miles distant from the laboratory and some distance from the line, was seen at the instant this record was obtained.

Company.⁵⁴ The oscillograph was located about four miles from the point where the line was struck, and flashover occurred. This voltage wave has a maximum rate of rise of 4000 kv per microsecond.

In Fig. 33 is shown the only oscillogram obtained from a direct stroke close enough to the recording equipment that the wave shape before flashover occurred is not distorted by propagation. This oscillogram was obtained by

Bell and Price⁵⁹ on a section of a 220-kv steel-tower line without ground wires of the Pennsylvania Power and Light Company. Flashover occurred 125 feet from the oscillograph on the phase to which it was connected, an outer conductor of a horizontal single-circuit configuration. The insulation level of the line is about 1300 kv and the voltage reached 2800 kv before flashover took place. The interval between the time when the voltage was high enough to operate the oscillograph and flashover occurred was about six microseconds.

The front of this surge is interesting. The voltage rose relatively gradually for more than three microseconds to about 500 kv. It then increased much more rapidly to the flashover voltage in about two microseconds, with an average rate of rise in this interval of about 1300 kv per microsecond. The relatively slow portion of the front is probably voltage produced before contact of the stroke to the phase wire by the advancing stroke leader. Upon contact of the stroke the voltage rose rapidly until flashover took place. The nature of the front of the voltage wave produced on phase wires is probably influenced by ground wires. For lines with ground wires the initial slow component of the front will not be so marked.

In Fig. 34 is shown a group of oscillograms obtained by the General Electric Company.⁶⁰ Fig. 34(a) is of interest because it is the first cathode-ray oscillogram obtained of

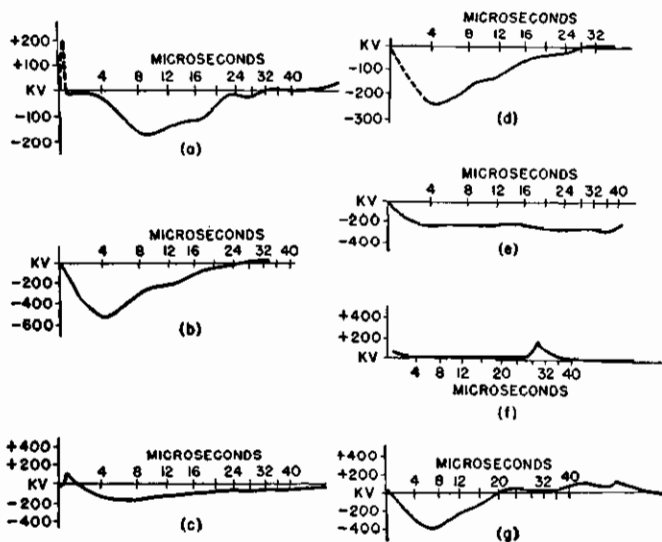

Fig. 35—Group of cathode-ray oscillograms of lightning voltage on transmission lines obtained by George and Eaton⁶².

a natural-lightning transient. Figs. 34(b)–(d) are typical of the three groups into which the 16 oscillograms exceeding 300 kv recorded by Smcloff and Price⁶¹ may be classified. Figure 34(b) is typical of records in which flashover occurs close to the recording equipment; Fig. 34(d) of voltages too low to cause flashover, but which are distorted by both propagation and negative reflections. The reversal of voltage is caused by such reflections, and the sloping off of the front results from propagation and reflections.

Fig. 35 shows a group of oscillograms published by George and Eaton.⁶² They all are of relatively low volt-

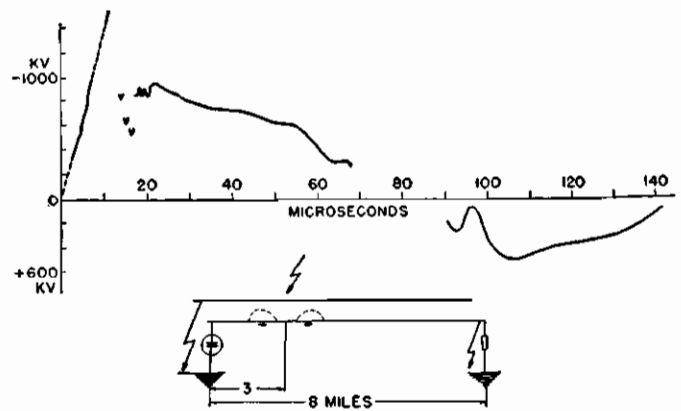

Fig. 36—Cathode-ray oscillogram of voltage due to natural lightning showing effect of propagation and reflections⁵⁸.

age and of surges originating quite a distance from the oscillograph station.

An interesting oscillogram which shows the effect of reflections is given in Fig. 36. This record⁵⁸ is of the voltage on a phase wire induced by a stroke to another phase wire and three miles from the oscillograph station. The wave front increased at a rate of 143 kv per microsecond to a magnitude considerably beyond the oscillograph range. At approximately 12 microseconds flashover occurred to the adjacent conductor reducing the voltage on the conductor to which the oscillograph was connected. The recorded voltage rose to 1000 kv after which it decayed to 600 kv in 55 microseconds. At this time the negative

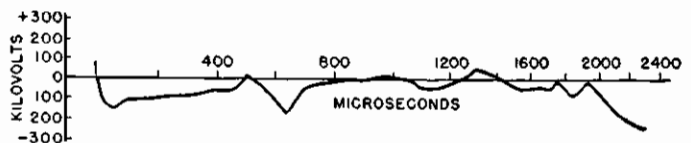

Fig. 37—Cathode-ray oscillogram of voltage due to natural lightning which shows the prolongation of the disturbance as a result of successive reflections⁵⁹.

reflected wave arrived from the far end of the line, a distance of eight miles from the oscillograph, where it had flashed over a noninductive resistance, thereby modifying the original tail of the wave as shown. This illustrates the typical effect of reflection on the tail of the wave.

These cathode-ray oscillograph studies led to the conclusion that the original voltage produced by the lightning stroke does not persist longer than 200 microseconds, but that successive reflections from different parts of the system may spread the disturbance out to as much as several thousand microseconds. Fig. 37 shows oscillograms illustrating this effect obtained by Bell and Price.⁵⁹ The long-duration low-current components of lightning surges, later found to be present, were not recorded. However, they are not important from the standpoint of voltage insulation.

23. Current Measurements

While the voltage on a transmission line is fundamental in determining whether an insulator string, gap, or arrester flashes over, it is difficult to determine what the voltages would be on the line if the insulation did not fail. However,

currents are not influenced to as great an extent by flash-overs. In addition, currents are important in their bearing on the mechanical stresses and thermal effects set up in protective devices and other equipment. For this reason most of the investigations during the past 17 years have been devoted to the determination of the current characteristics of lightning strokes. These investigations can be given three classifications:

(a) *Strokes to Open Ground and Tall Buildings.*

These comprised the following investigations:

1. Schonland, Malan, Hodges, and Collens¹³⁻¹⁷ in South Africa who studied the mechanism of lightning with the Boys camera and by measurement with the cathode-ray oscillograph of the electric field produced by strokes.

2. Stekolnikov and Valeev²² in Russia who measured, with the cathode-ray oscillograph and high-speed rotating klydonograph, currents in strokes to captive balloons flown to altitudes between 500 and 800 meters and voltages induced in a short horizontal antenna by strokes to ground.

3. McEachron^{11,63} who measured currents in strokes to the Empire State Building in New York, N. Y., with the cathode-ray and crater-lamp oscillographs and the surge-crest ammeter.

4. Norinder⁶⁴ in Sweden who measured with the cathode-ray oscillograph the magnetic fields produced by lightning-strokes.

5. Wagner, McCann and Beck^{65,85} who measured with the fulchrograph, magnetic surge-front recorder, surge-crest ammeter, and magnetic surge integrator, the currents in tall objects of different heights.

(b) *Strokes to Transmission Lines.* These include the following investigations made with the surge-crest ammeter:

6. Lewis and Foust⁶⁶ who measured surge currents in transmission-line towers, ground wires, counterpoises, and tower masts.

7. Waldorf and Hansson^{55,57} who measured surge currents in tower legs.

8. Bell^{67,68} who measured currents in tower legs and cross braces and in counterpoises.

9. Grunewald⁶⁹ in Germany who measured current in towers.

10. Rokkaku and Katoh^{53,70} in Japan who measured currents in tower legs and ground wires.

11. Andrews and McCann⁸⁸ who measured surge currents on wood-pole lines.

In addition to the foregoing are the following investigations made with other instruments:

12. McEachron⁷¹ who measured with the crater-lamp oscillograph currents discharged by protector tubes on transmission lines.

13. Berger⁷² in Switzerland who, besides measuring transmission-line tower-leg currents with the surge-crest ammeter, recorded their maximum rate of rise with klydonographs inductively coupled with the tower legs.

(c) *Arrester Discharge Currents.* The following investigations were made with surge-crest ammeters:

14. McEachron and McMorris⁴⁶ who measured discharge currents in distribution arresters on 120- to 20 000-volt systems.

15. Gross and McMorris⁷³ who measured discharge currents in station-type arresters on 11- to 132-kv systems.

16. Grunewald⁷⁴ in Germany who measured arrester currents on systems from 6 to 100 kv.

In addition to the foregoing are the following investigations made with other instruments:

17. Collins³⁹ who used paper-gap recorders to measure discharge currents in arresters on a 24-kv system.

18. Wagner, McCann, Bowen, and Beck^{65,66,90} who measured the discharge currents in arresters by means of the fulchrograph, magnetic surge-front recorder, magnetic-surge integrator, and surge-crest ammeter.

19. Gross, McCann, and Beck⁸³ who measured discharge currents in arresters by means of the cathode-ray oscillograph, fulchrograph, magnetic surge-front recorder, and surge-crest ammeter.

24. Multiple Character of Strokes

In Figs. 38 to 40 are plotted curves giving statistical data on the number of components, the time intervals between them and the total duration of strokes. These curves

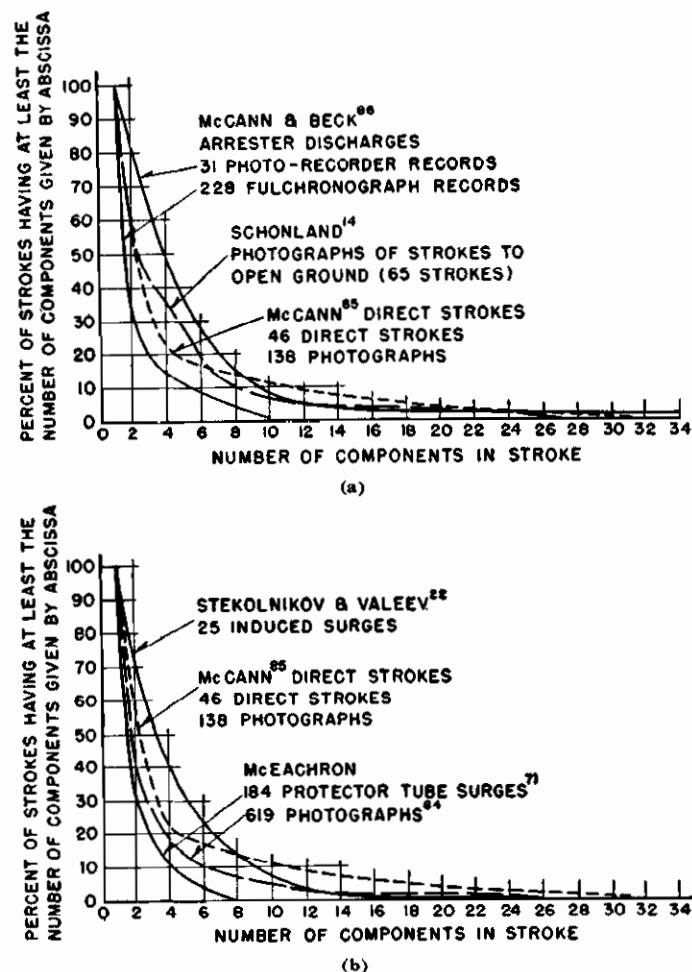

Fig. 38—Percentage distribution curves of the number of components in lightning strokes.

represent data on strokes of three general types: (1) strokes to power systems as given by the protector-tube and arrester data; (2) strokes to open country as given by the photographic records and the data on induced voltages; (3) strokes to tall objects. With regard to number of components and total duration, there is a fair check between the curves of each type, but there are important differences between the types. More components and longer durations are recorded for strokes to tall objects. This is probably because tall projections from the earth affect stroke mech-

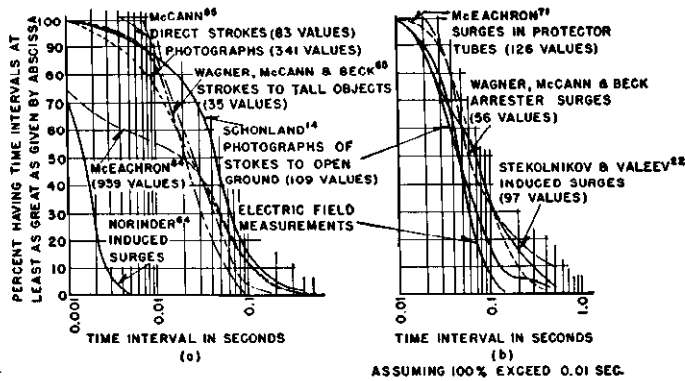

Fig. 39—Percentage distribution curves of time intervals between the beginnings of successive components of multiple lightning strokes.

anism and cause strokes to them to differ in character from those to ground or to lower objects. Tall objects should influence a greater region of the thundercloud and thus tap more charge centers, causing strokes to have more components and longer durations. Of practical importance is the indication that the records to power systems have fewer components and shorter durations. This results probably from the diminution of the surge current by the following causes: (1) All of the direct-stroke current is not likely to pass through a protective device because more than one may operate, thus dividing the current, or flashovers may occur on the lines thereby limiting the discharge current; (2) the protective device may be operated by attenuated surges from strokes to the system at remote points; (3) the protective device may be discharged by induced surges. Thus some of the smaller components of current may have been reduced to such an extent that they are below the recording range of the instruments, or have voltages associated with them below the operating voltage of the protective device. Arresters and other terminal equipment are therefore exposed to less severe duty than is indicated by the results from direct strokes or strokes to open country. Only about a third of power-system surges are multiple and the maximum number of components

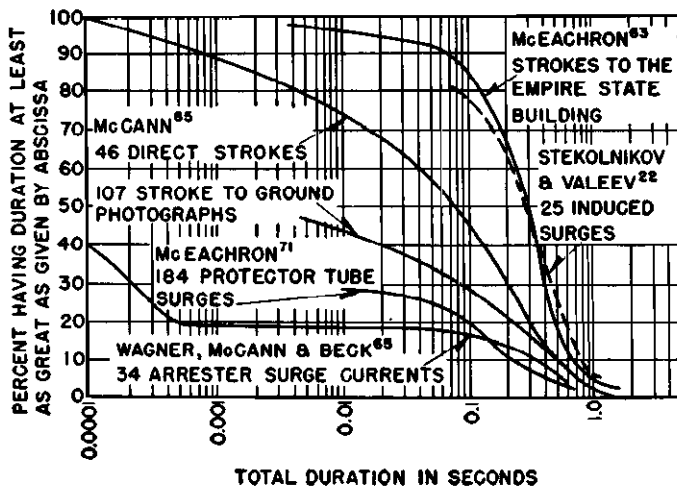

Fig. 40—Percentage distribution of total duration of lightning strokes.

recorded is 10. From one-half to two-thirds of the strokes to open country are multiple and as many as 40 components have been photographed.²⁰

Fig. 39 indicates time intervals as high as 0.5 second between components. In Fig. 39(b) the basis of 100 percent was taken at a time interval of 0.01 second as the resolving power of some of the measuring instruments did not extend below this time. Only about a sixth of the intervals are less than one-half cycle of 60-cycle frequency.

25. Crest Magnitude of Currents

Extensive studies have been made both in the United States and abroad with surge-crest ammeter links on transmission lines and in ground leads of lightning arresters. Most of the measurements on transmission lines have been of currents in the legs of towers, although they have also been made of currents in ground wires, phase wires, counterpoise wires, and masts mounted on top of towers.

Transmission-Line-Tower Currents—The curves of Fig. 41, showing the magnitude of currents in transmission-

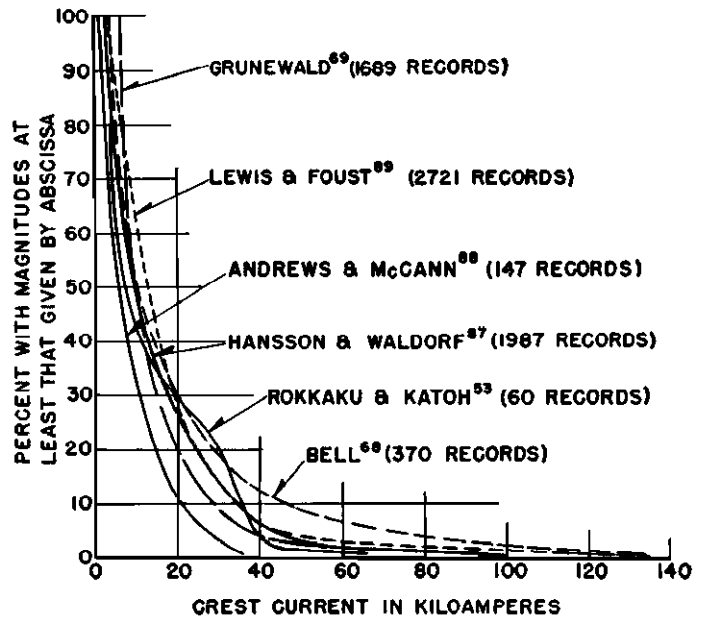

Fig. 41—Percentage distribution curves of tower currents for strokes to transmission lines.

line towers, were compiled only from the currents in the tower thought to be close to the terminating point of the stroke or the tower carrying the most current. The character of the curves is influenced by the minimum current that could be measured due to the sensitivity limit of the links and the minimum different investigators thought it advisable to include in their data. These minimum values affect both the point regarded as 100 percent on the ordinate and also the shape of the curve. The minimum tower currents included in the data of Hansson and Waldorf³⁷ were about 2400 amperes for Bell⁶³ and Grunewald⁶⁹ about 5000 amperes, and for Andrews and McCann⁸⁸ about 600 amperes. The curves of Lewis and Foust⁶⁶ comprise some of the data of Waldorf and Bell plus data obtained on other lines in the United States. However, 5000 amperes was the minimum considered by them.

Before drawing any conclusions from these curves it is well to consider their probable accuracy. The majority of the magnetic-link measurements of steel-tower currents were made on only one leg of the tower, the total current being assumed to be this measurement multiplied by the number of tower legs. Records obtained with links on all tower legs indicate that frequently currents are not equally distributed. Data obtained by Waldorf, shown in Fig. 42

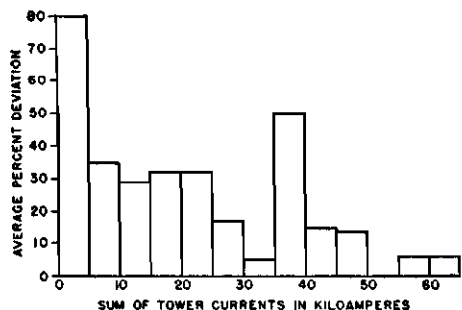

Fig. 42—Deviation from equal division of lightning current in tower legs, as obtained by Waldorf⁵⁵ from 209 records.

indicate the mean deviation of an individual tower leg from the mean of the four supporting legs. This deviation appears to decrease as the sum of the four tower-leg currents increases, being about ten percent above 40 000 amperes. Factors that might cause such discrepancies are dissymmetry in the counterpoise or other type of grounding or in the tower itself. These factors might even result in differences in wave shape of the component currents. In addition, there are the possible errors of the recording equipment, particularly at low currents. It is probable, however, that some of these effects are minimized by the quantity of data making up the statistical averaging of several hundred records.

Data obtained by Bell⁶⁷ who also measured the currents in the tower cross braces show that appreciable current flows in them. His results indicate that a correction factor varying from 1.64 to 2.75, with a mean of about 2, should be applied to the tower-leg current readings for his records. Lewis and Foust⁶⁶ say that from 30 to 100 percent of the main leg currents flowed in the cross braces.

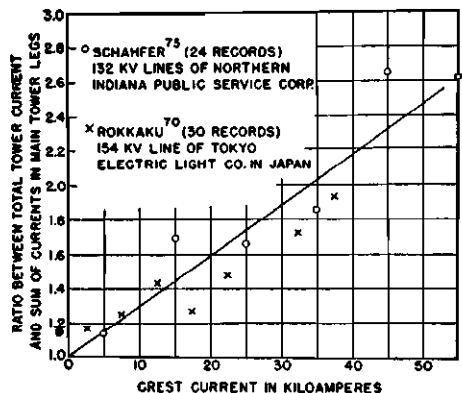

Fig. 43—Relation between total tower lightning current and sum of main tower-leg currents in transmission-line steel towers.

Rokkaku⁷⁰ and Schahfer and Knutz⁷⁶ made studies in which they measured the main leg currents and the difference between the ground-wire currents on each side of the tower. Assuming this difference to be the total tower current gives an indication of the discrepancy between the total tower current and the sum of the leg currents. Their results are summarized in Fig. 43, which indicates that this correction factor should increase with the magnitude of the tower current. The curves of Fig. 41, so far as the authors are aware, do not take this correction factor into consideration and are plotted simply as the sum of the four tower-leg currents.

Direct-Stroke Currents—Fig. 44 gives percent distribution curves for direct strokes as a function of the

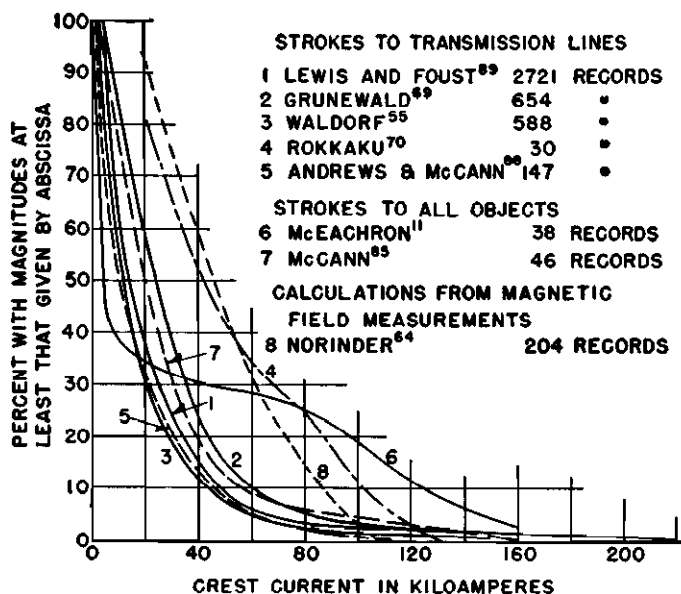

Fig. 44—Percentage distribution curves of lightning-stroke currents.

crest magnitude. Curves 1 to 3, which are for strokes to transmission lines, were obtained by adding the tower-leg currents in all the towers thought to be involved in the stroke. Errors introduced by this procedure are the following: First, the sum of the tower-leg currents may be less than the total tower current; second, the effects of more than one stroke might be involved in summing the currents of different towers; and, third, because of distortion as the result of reflection from other towers, the sum of the crest currents at the towers will not equal the stroke current. The first item tends to indicate a low value of stroke current, and the second and third a high value. Rokkaku in comparing the results of stroke measurements obtained by summing the ground-wire currents on both sides of the terminating point of the stroke with the results obtained by summing the tower currents found that the two agree where the correction factor of Fig. 43 is included. Their Curve 4 of Fig. 44 takes this factor into consideration. However, Lewis and Foust in data presented in Fig. 45 showed substantial agreement between stroke currents and sum of tower currents without including the correction factor of Fig. 43. The effect of this factor may be reflected

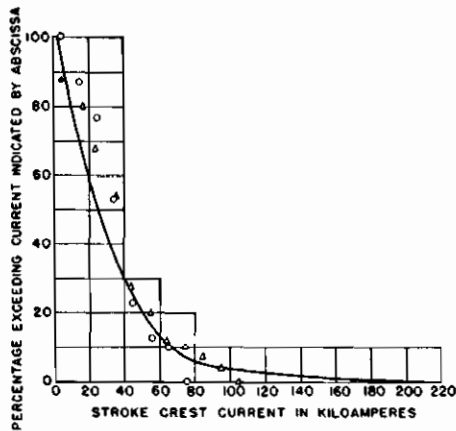

Fig. 45—Lewis and Foust⁶⁶ stroke-current curve compared with currents from lightning-rod measurements (circles) and overhead ground-wire measurements (triangles).

in the comparison between Curves 1 and 4 of Fig. 44, in that Rokkaku's is greater than Lewis and Foust's.

Fig. 44 also contains data relating to strokes to tall objects, that of McEachron being to the 1250-foot Empire State Building in New York, N. Y. The curve of McCann represents data to objects of varying heights all of which are considerably lower. Neither of these curves involves the errors discussed previously as the total stroke current passed through a single conductor. A comparison of McEachron's curve data with those of strokes to transmission lines indicates a much greater proportion of currents of low magnitude. This may be caused partly by the higher sensitivity of McEachron's instruments but more likely by the difference in mechanism of strokes to tall objects and the influence of tall projections from the earth in producing premature initiation of discharges.

Curve 8 of Fig. 44 was calculated by Norinder from a knowledge of the magnetic field disturbance produced by a stroke to open ground. An evaluation of the accuracy of this curve is difficult because it involves an assumption as to the stroke mechanism, distance to stroke, and direction and length of stroke path.

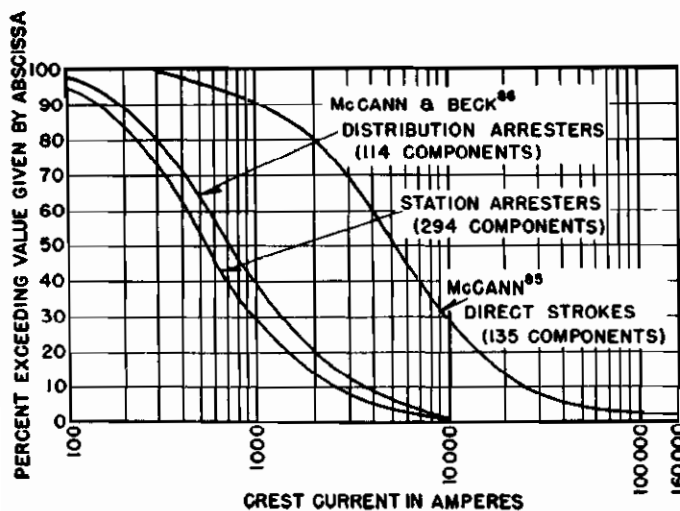

Fig. 46—Percentage distribution curves of crest magnitude of individual components of surge currents.

The direct-stroke curve of Fig. 46 gives the percent distribution of the crest magnitude of the individual components of direct strokes to objects varying in height from 300 to 585 feet. A comparison of this curve with Curve 7 of Fig. 44 shows a larger proportion of small currents for the former. This is because only the maximum components of the multiple strokes were included in Curve 7 of Fig. 44. The curves of Fig. 46 are probably more representative of conditions for judging arrester performance.

Crest currents as high as 220 000 amperes are indicated for strokes to lines. However, since these were obtained by

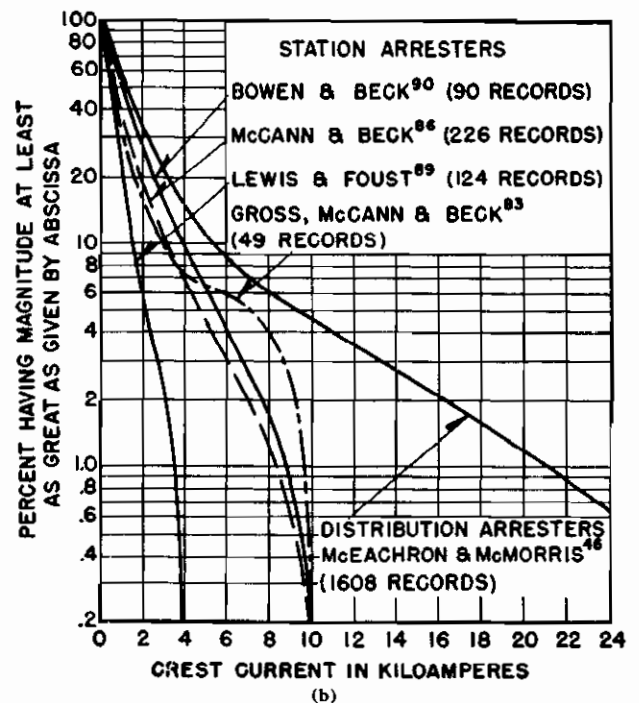
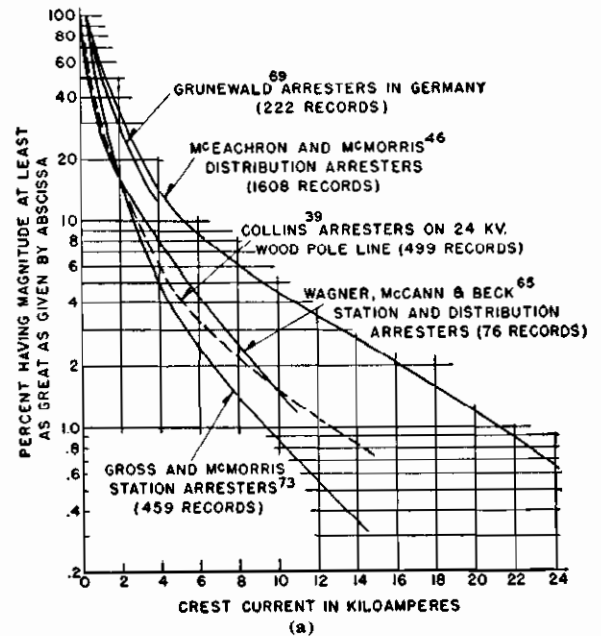

Fig. 47—Percentage distribution curves of discharge currents in lightning arresters.

adding currents in several towers they may be high. The highest current definitely known to have occurred somewhat exceeds 160 000 amperes, recorded at the Westinghouse recording station on the 585-foot smokestack of the Anaconda Copper Mining Company in Anaconda, Mont.

Arrester Currents—Crest magnitudes of arrester discharge currents, summarized in Fig. 47, are considerably smaller than those occurring on transmission lines. Those in station arresters, in general, are smaller than those occurring in distribution arresters. The maximum crest current measured in station arresters is 15 000 amperes and in distribution arresters approximately 30 000 to 40 000 amperes. The latter figure has been estimated since the maximum range of the recording instruments was 25 000 amperes. Other data pertinent to the magnitude of arrester discharge currents are discussed later.

26. Charge

Wilson⁹ has estimated that the average charge lowered by a discharge to open ground is from 10 to 50 coulombs. Fig. 48 gives data on charge for strokes to the Empire

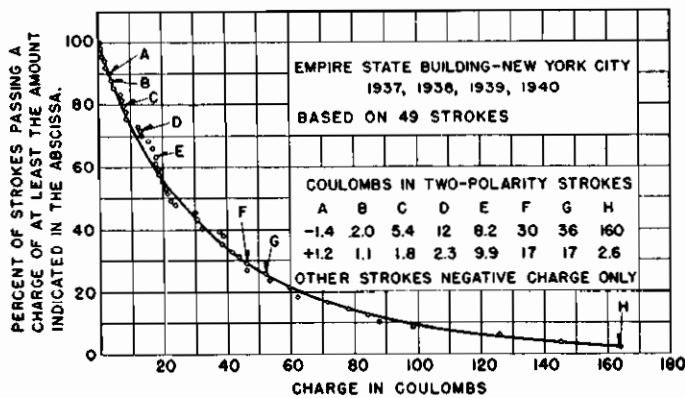

Fig. 48—Frequency of occurrence of stroke charge as measured by McEachron,⁶³ based largely on low-speed oscillographic data.

State Building by McEachron, which indicate values in excess of 160 coulombs. In the investigations of Wagner, McCann, and Beck⁶⁵ charges in direct strokes to tall objects of lower height ranged from 4 to 60 coulombs. Probably on the average the charge lowered increases with the height of the object. Charges exceeding one coulomb were found to be rare for arrester service.

27. Polarity

Direct strokes of a given polarity produce surges of the same polarity, but induced surges are of opposite polarity. Schonland, Hodges, and Collins¹⁷ state that all their electric field measurements indicated negative-polarity strokes; that is, they lowered negative charge to ground. All 58 strokes recorded to the Empire State Building were initially negative; only 3 of the 27 recorded with the crater-lamp oscillograph reversed their polarity. Of the 12 direct strokes recorded by Wagner, McCann, and Beck⁶⁵ all were initiated by negative discharges. Only two had subsequent positive components.

Lewis and Foust⁶⁶ state that 7 percent of their records

of strokes to transmission lines were of positive polarity, while Waldorf⁵⁵ found 18 percent and Grunewald,⁶⁹ 14 percent. Waldorf's figure may be higher than the others because his data comprised lower currents. If this is true, a higher percentage of the lower-magnitude currents should be positive. This is borne out in the curves of Fig. 49

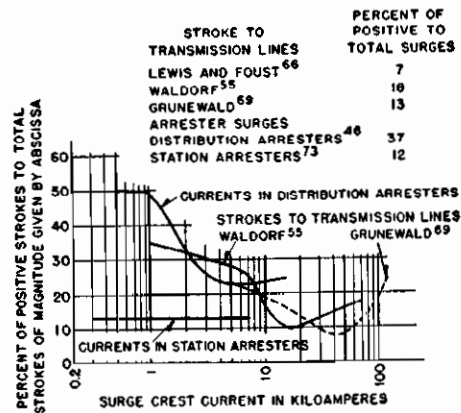

Fig. 49—Percentage distribution curves of positive surges as a function of current magnitude.

plotted from Waldorf's and Grunewald's data showing the percentage of total positive currents as a function of magnitude. At the minimum of 1000 amperes Waldorf's data show that about 35 percent of the records are positive, and Grunewald's, with a minimum of 5000 amperes, show about 24 percent.

Possibly currents as great as 5000 or 10 000 amperes can be produced in towers by induced strokes, and they may be the cause of the higher percentage of positive records in the lower current range.

The studies of McEachron and McMorris show that 63 percent of all their records of currents in distribution arresters are negative and 37 percent positive, while Gross and McMorris found that for the station arresters 88 percent were negative and 12 percent positive. The curves of Fig. 49 plotted from these data show that for station arresters, the polarity is independent of current magnitude while for distribution arresters the number of positive discharges decreases with increase in current magnitude.

It is interesting to compare these results with the voltage measurements made on 4-kv distribution circuits by Halperin and McEachron, the results of which are shown in Fig. 30. If these voltages had appeared across 4-kv arresters with an impulse breakdown voltage of about 40 kv, the voltage curves for urban circuits indicate that 22 percent of the arrester discharge currents would have been positive, and the curves for rural circuits indicate a figure of about 35 percent. If these voltages had appeared on a 20-kv circuit with arresters having an impulse breakdown voltage of about 75 kv, no positive discharge currents would have been produced by the urban circuits and 27 percent would have been produced by the rural circuits. The increase in positive discharge currents recorded in distribution arresters probably is due to induced surges. Quite likely they are greater on the lower-voltage circuits,⁶⁶ and greater the

TABLE 1—DATA ON STROKES TO LINES OF THE PENNSYLVANIA WATER AND POWER COMPANY^{65,67}

Line	Length in Miles	Year	Recorded Strokes		Strokes Per 100 Miles*	
			In Year	Average	In Year	Average
Safe Harbor-Westport-Takoma, 220 kv. . . .	91.8	1935	115	125	105 (95)
		1936	108	118	
		1937	87	95	
		1938	54	59	
		1939	118	129	
Safe Harbor-Riverside, 220 kv.	50.5	1938	46	91	90
		1939	45	89	
				46		
Safe Harbor-Perrysville, 132 kv.	31.5	1935	27	86	154 (135)
		1936	69	219	
		1937	44	140	
		1938	56	166	
		1939	53	157	
Holtwood-York, 66 kv.	22.8	1936	31	136	120 (119)
		1937	41	180	
		1938	15	66	
		1939	22	97	
Holtwood-Coatesville, 66 kv.	29.4	1936	30	102	143 (123)
		1937	25	85	
		1938	68	232	
		1939	45	153	
Holtwood-Baltimore, 66 kv (2 lines) and Philadelphia Road-Gunpowder, 110 kv.	40 (of right-of-way)	1939	66	66	165	165

Weighted average for all lines through 1939 is 120 strokes per 100 mile-years having magnitudes giving tower currents in excess of 2400 amperes.
 *Figures in parentheses are averages extending through 1942⁶⁷ and represent 1364 mile-years of experience.
 System average strokes per 100 miles of line per year is 113 for five observed lines totaling 1617 mile-years of experience.

more exposed the lines, thus permitting higher magnitudes of induced surges.

28. Number of Strokes to Transmission Lines

Of particular importance in evaluating lightning performance of a transmission line is knowledge of the probable number of strokes to it. Hansson and Waldorf^{65,67} present valuable data on this subject from surge-crest ammeter studies on lines of the Pennsylvania Water and Power Company with voltage ratings ranging from 66 to 220 kv, as magnetic links were placed on every tower. These data for the first five years are summarized in Table 1 and show a maximum variance in the number of strokes per 100 miles of line per year of from 59 to 232. The maximum variance for any line over the eight-year period studied⁶⁷ was from 48 to 232 and the variance of the average for each line over the eight-year period was from 95 to 135 strokes per 100 miles per year. The weighted average of the data according to length of line and years considered is 113. These lines are located in a region with annual isokeraunic levels from 35 to 40. Converting the figure of

TABLE 2—OUTAGES DUE TO LIGHTNING FOR LINES WITHOUT GROUND WIRES

Line	Kv	Length of Line	Years Covered	Total Outages	Outages Per 100 Miles Per Line-Year
Interstate Power Co., Clinton-Dubuque ⁷⁸	66	54	6	277	87
Pa. Water & Power Co., Holtwood-York ⁷⁹	66	23	11	213	84
Various lines in United States and Canada*					
16-A, wood.	110	79.4	6	24
20-A, steel.	140	148.0	10	5.6
23-BB, wood.	132	39.8	8	37.2
31-B, steel.	132	111.0	1	0
34-K, steel.	110	38.3	10	61
34-O, steel.	110	104.5	10	22.8
Steel ⁸¹	Above	673	1929	21
		100	1930	14
Wood ⁸²	60-100	394	1929	26.6
Steel ⁸²	60-100	481	1929	23.5
		738	1930	25.9
Wood ⁸²	30-60	3 475	1929	34.6
		420	1930	30.4
Steel ⁸²	30-60	165	1929	17.6
		128	1930	14.2
Pa. Power & Light Co., steel ⁶⁷	220	41	8	25

⁶⁷For numbered references see list at end of article.
 *See Table 1 of the Appendix.

113 to the conventional standard isokeraunic level of 30 results in 97, or about 100 strokes per 100 miles per year.

Additional information is provided by available lightning outage records of lines without ground wires. Data of this nature are summarized in Table 2. The lines listed in this table are in regions with annual isokeraunic levels ranging from about 30 to 55, and the data give outages varying from 15 to 87 per 100 line-miles per year, with an average weighted according to length of from 30 to 35.

All strokes to lines do not produce flashover, and all flashovers do not produce outages. Data published by Bell⁶⁷ indicate a ratio of 1.5 between the number of strokes producing flashover and those producing outage on the portion of the 220-kv Wallenpaupack-Siegfried line of the Pennsylvania Power and Light Company that does not have ground wires. Information supplied by I. W. Gross on the 132-kv lines of the American Gas and Electric Company (which have ground wires) indicates a ratio of 1.27. This ratio probably varies with the system, being higher the longer the flashover path and the lower the fault current. An estimate of the number of strokes producing flashover on a given line without ground wires can be obtained from, say, Curve 3 of Fig. 44, together with a knowledge of the surge impedance of the line and its insulation level. The voltage produced by a stroke to a phase conductor should be equal to the product of one-half the stroke current and the surge impedance of the conductor. Estimates of the probable mean ratio between outages and

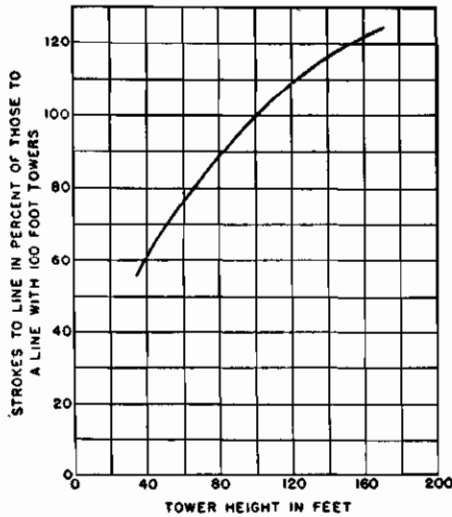

Fig. 50—Probable variation of strokes to line as a function of height.⁷⁶

strokes to lines without ground wires for the lines listed in Table 2 indicate a mean value for strokes to lines of about 60 per 100 line-miles per year. This is, of course, only an estimate, and probably the figure of 100 based on Waldorf's data should be used in a region of isokeraunic level of 30.

Lightning-performance studies of lines made in the laboratory with models by Wagner, McCann, and MacLane⁷⁶ indicate that the number of strokes to the line is a function of tower height as shown in Fig. 50. However, no such trend is shown in Waldorf's data. This is probably because

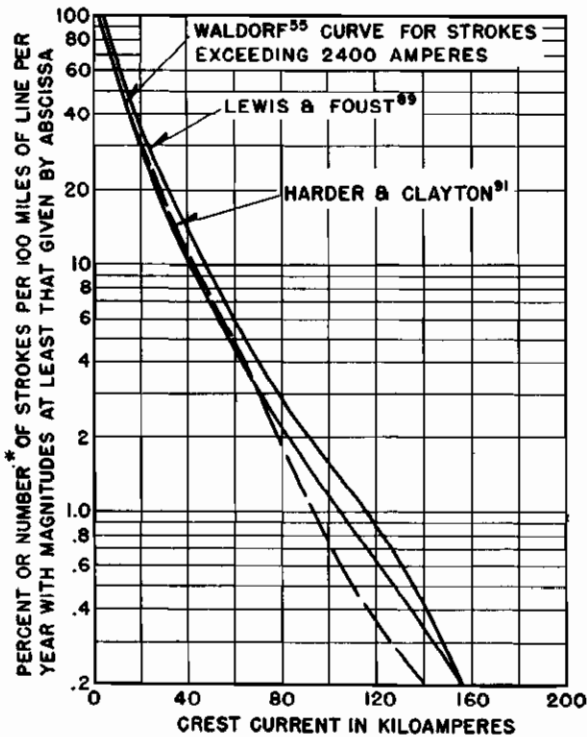

Fig. 51—Probability curves of crest currents in lightning strokes to transmission lines.

*Based on 100 strokes to line per 100 miles of line per year.

other factors such as line locations cause a greater variance. Thus the average value of 100 should apply to all practical values of tower height.

It is then possible to plot Waldorf's percentage distribution curve in Fig. 44 as a probability curve giving the number of strokes of a given magnitude to be expected. This is shown in Fig. 51 with the corresponding curve of Lewis and Foust which is Curve 1 of Fig. 44. The probability curve used by Harder and Clayton⁹¹ for estimating line performance is also given in Fig. 51. This curve is essentially based on the data published by Waldorf⁵⁵ except that it has been modified slightly in the high-current region. The data of this figure are on a line basis and not a circuit basis; the number of strokes to a line is independent of the number of circuits comprising it.

29. Number of Surges Discharged by Lightning Arresters

Fig. 52 shows curves compiled from the data of Gross and McMorris⁷³ and McEachron and McMorris⁴⁶ on the

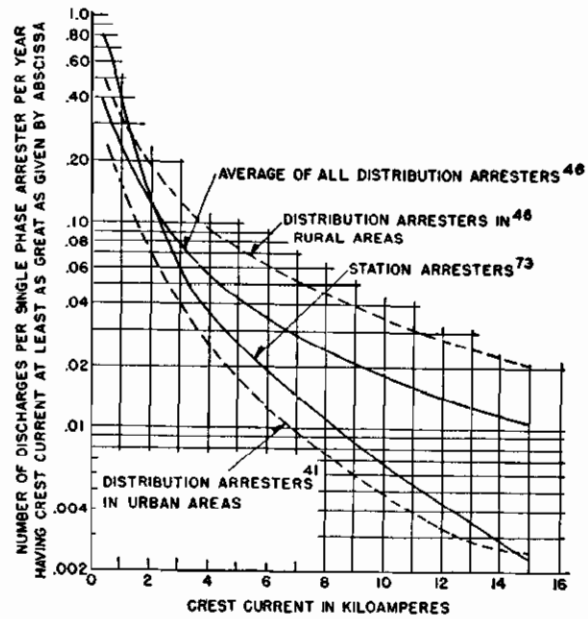

Fig. 52—Curves showing number of surges of given magnitudes that arresters discharge per year.

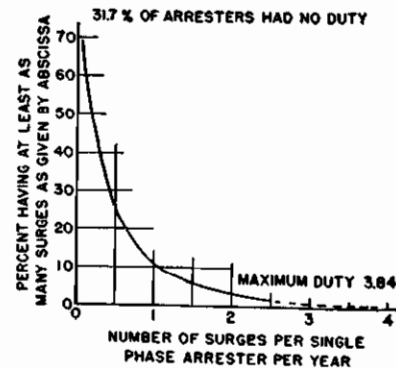

Fig. 53—Distribution of duty on station arresters; data from Gross and McMorris⁷³ on 85 three-phase banks for four-year period.

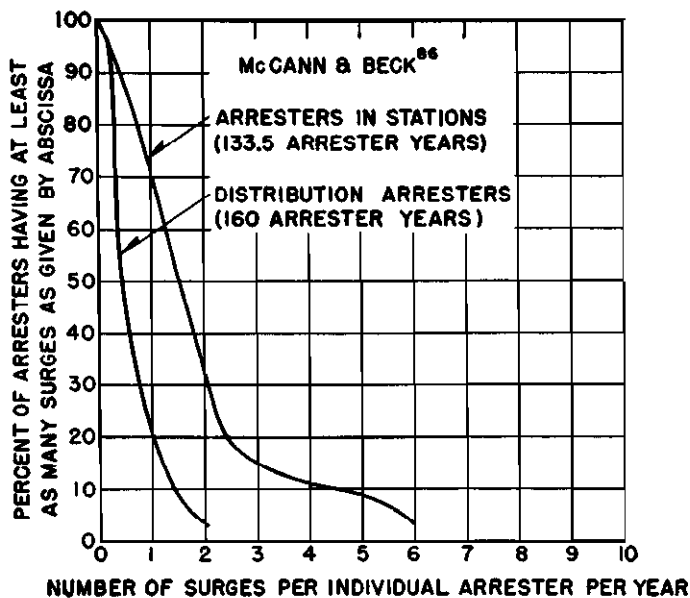

Fig. 54—Duty on individual arresters from data obtained by McCann and Beck.⁶⁶

expected number of surges of a given magnitude to be discharged per single-phase arrester per year. The curves indicate an average of 0.8 surge exceeding 300 amperes for station arresters, but only 0.4 for all distribution arresters. Rural distribution arresters experience more than urban arresters, because of the greater density and better shielding of urban arresters. Rural distribution arresters, although having fewer surges than station arresters, are required to discharge higher currents.

Figs. 53 and 54 show the distribution of duty among individual arresters. Fig. 53, drawn from the data reported by Gross and McMorris, shows that for a group of station arresters 32 percent discharged no surges in four years, only 25 percent discharged two, and the maximum number discharged was 3.84 per single-phase arrester per year. The

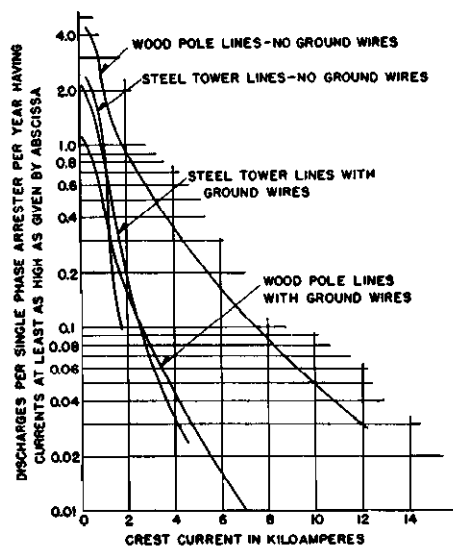

Fig. 55—Effect of line construction on number and magnitude of station-arrester discharge currents; Gross and McMorris.⁷³

curve of Fig. 54 indicates more discharges. This may not be typical of duty on an average group of arresters, as the locations were chosen because experience indicated that they were subject to severe lightning conditions.

The effect of line insulation on arrester duty is shown in Fig. 55. Wood-pole lines with no ground wires, as would be expected, produce more severe duty.

30. Wave Shape of Lightning Currents

An inherent difficulty in measuring the total current in direct strokes is the necessity of obtaining a point at which the current is totalized. This has led to collecting the current in a single mast. If, however, these masts are on low objects such as transmission towers, the chance of a particular point being struck is small. On the other hand, if tall objects such as buildings and smoke stacks are utilized, more records for a single installation can be obtained but it is always uncertain how much such strokes differ from those to lower objects, as dealt with in the power-transmission problem. It is known, for example, that the initial streamers, the direction of propagation, and other vital characteristics differ in the measured discharges at the Empire State Building from those elsewhere. In spite of these uncertainties, most direct-stroke data have been obtained on tall objects.

Stekolnikov and Valeev²² in Russia in 1936 obtained the first oscillograms of the current in direct strokes. These studies were made with a balloon attached to a metal cable and flown at altitudes between 500 and 800 meters during a thunderstorm. Resistance shunts were connected directly in the cable circuit for a cathode-ray oscillograph and a high-speed rotating klydonograph. In addition, a short horizontal antenna about 20 meters above the ground was used with a cathode-ray oscillograph and a rotating klydonograph. During the lightning season only two storms occurred near the lightning station, but six strokes to the vertical antenna were recorded, five in one storm. The cathode-ray oscillogram of one of these is shown in Fig. 56,

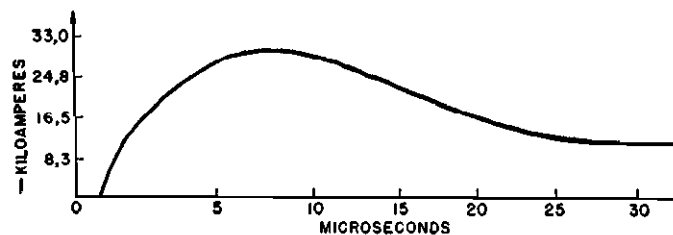

Fig. 56—Cathode-ray oscillogram of current in lightning stroke to captive balloon.²²

and data on the five strokes that could be analyzed are given in Table 3. These records indicate fronts of from 1½ to 10 microseconds and rates of rise of from 1.8 to 9 kiloamperes per microsecond. The maximum duration as recorded by the oscillograph was not over 50 microseconds, but the instrument was not very sensitive. Some of the rotating klydonograph records of the individual components of the induced surges on the horizontal antenna, however, indicate durations from 2600 to 10 000 microseconds.

Several cathode-ray oscillograms obtained by McEachron⁷⁷ show the wave shape of the initial high-current portion of successive components of multiple strokes. Oscillograms for two of these strokes are shown in Fig. 57. The first (a) is of a single stroke having a crest current of about 15 000 amperes, a front of about 4 microseconds, and a time to half value of about 75 microseconds. The second two oscillograms (b, c) are of two components of a multiple stroke. Each has crest values of about 20 000 amperes, fronts of about 10 microseconds, and times to half value of about 70 microseconds.

McEachron concludes that the current between components of a stroke is continuous, although in many cases

it may be only a few amperes. An example of a crater-lamp oscillogram showing the presence of such currents between successive peaks is given in Fig. 58. This oscillogram is also interesting in that it confirms an essential difference between the types of discharge to high and low objects.

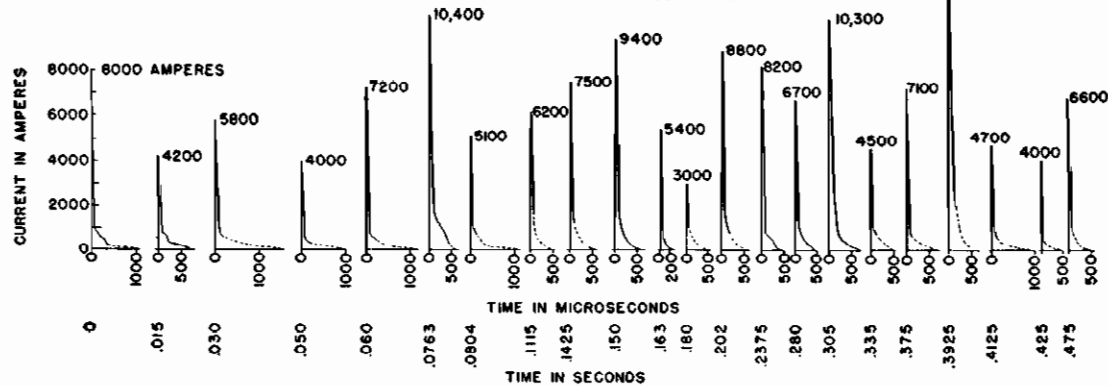
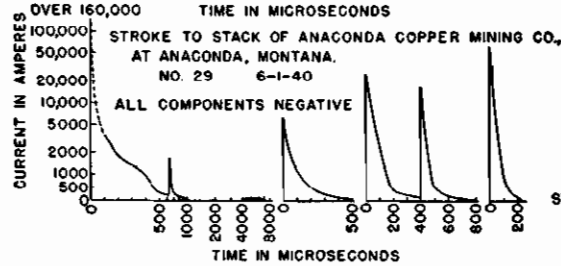
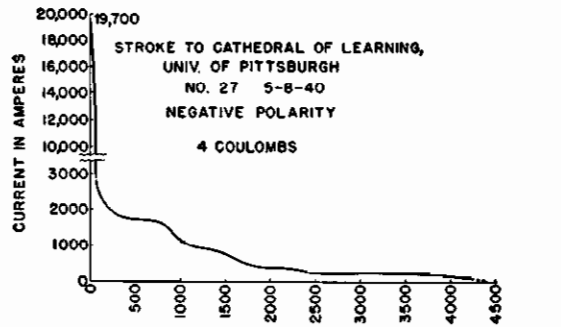
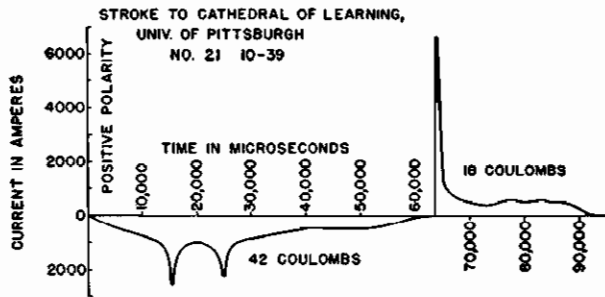

Fig. 59—Fulchronograms of currents in direct strokes.⁷⁸

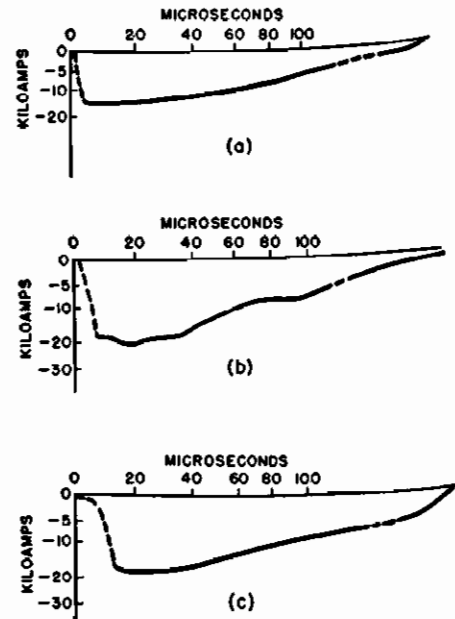

Fig. 57—Cathode-ray oscillograms of the currents in two strokes to the Empire State Building.⁷⁷

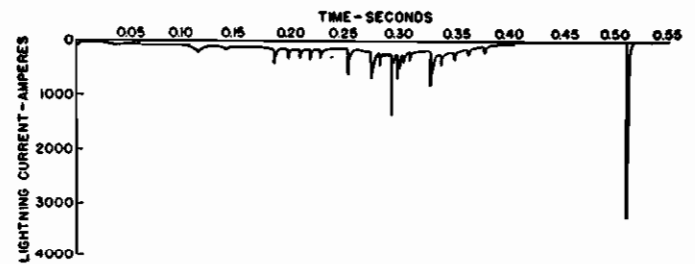

Fig. 58—Crater-lamp oscillogram of stroke to the Empire State Building by McEachron,⁷⁷ showing successive peaks and continuing current.

TABLE 3—TABULATED DATA ON FIVE STROKE-CURRENT OSCILLOGRAMS OBTAINED BY STEKOLNIKOV AND VALEEV²²

Oscillogram number	1	2	3	4	5
Crest value of current in kiloamperes	30	18	31	17	30
Front of wave in microseconds	8	10	3.5	10	1.5-2.0
Maximum rate of rise of current in kilo-amperes per microsecond	6.6	7.6	25	4.0	
Mean rate of rise in kiloamperes per microsecond	3.8	1.8	9.0	1.7	
Measurable duration in microseconds	35	45	30	23	

Polarity—all negative but last one, which was oscillatory.

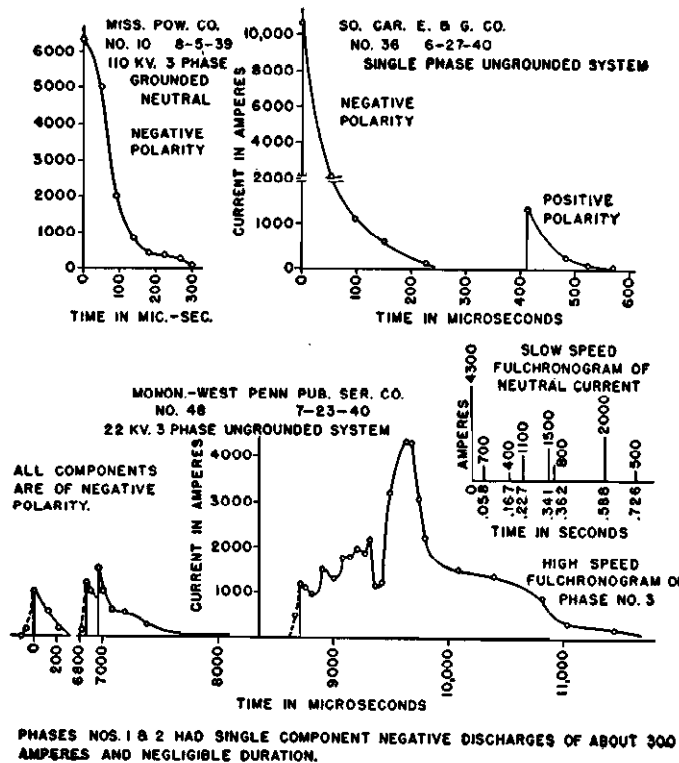

Fig. 60—Fulchrograms of lightning-arrester discharge currents.⁶⁶

The vast majority of the discharges to the Empire State Building were initiated by upward streamers from the building, and until this streamer tapped a concentration of charge in the cloud the record indicated a low magnitude of current as shown in Fig. 58 for the first few tenths of a second.

Wagner, McCann, and Beck⁶⁵ have presented data obtained with the fulchrograph on subjects varying between 300 and 600 feet in height. Of twelve records obtained only one shows evidence that the discharge was initiated by an upward streamer. This record was obtained at the Cathedral of Learning of the University of Pittsburgh, Pa., and is No. 21 shown in Fig. 59. This figure also shows fulchrograms of direct strokes of the more conventional type. The Anaconda No. 29 represents the

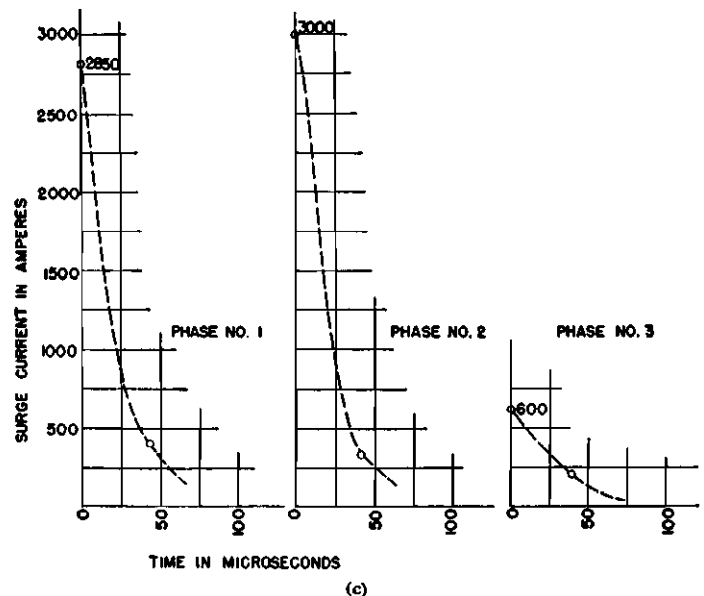
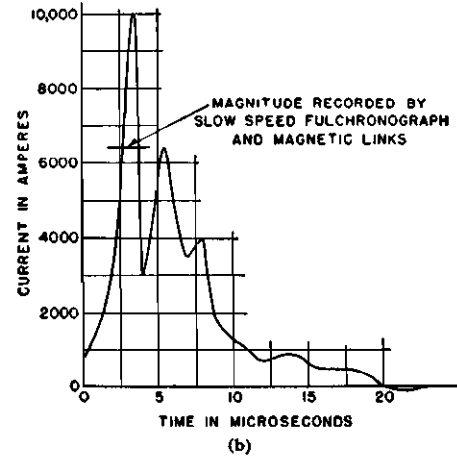
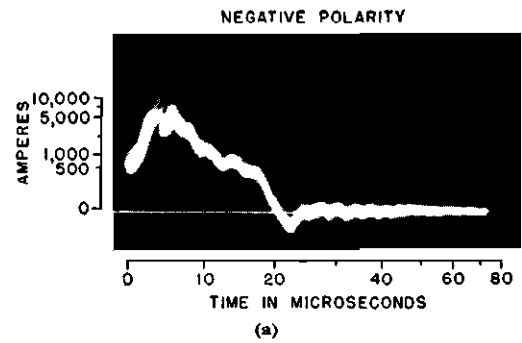

Fig. 61—Record of arrester discharge currents obtained at the 33 kv Stone Creek Substation of the Ohio Power Company.⁶⁵

- (a) Cathode-ray oscillogram of current in the common ground.
- (b) Replot of cathode-ray oscillogram in linear coordinates.
- (c) Fulchrograms of current in the individual arrester phase legs.

maximum measured lightning current for which the measured current flowed through a single conductor. Record No. 34 has the largest number of components of the fulchrograms obtained in this investigation, and shows, furthermore, that the maximum component does not always occur near the beginning of the stroke. A similar

phenomenon was observed with photographic studies.⁶⁵ Several fulchronograms of current discharged by arresters are shown in Fig. 60. A cathode-ray oscillogram of the neutral current and fulchronograms of phase currents for a lightning discharge of a three-phase arrester bank are shown in Fig. 61.

31. Wave Shape of Initial High-Current Portion of Surge

Time to Half Value—Fulchronograms^{65,66} giving the current wave shape and duration have been obtained of 46 direct strokes having 118 components, and of station arrester discharges having 223 components, and of distribution arrester discharges having 83 components. Excluding four low-magnitude components of strokes that were initiated by upward streamers, the times to half value of the direct-stroke records of the initial high-current portions varied from approximately 15 to 90 microseconds, with 50 percent of the components having a time to half value of 43 microseconds. The times to half value of the station arrester surges varied from 10 to 120 microseconds, with 50 percent of the surges having a time to half value of 27 microseconds. The times to half value of the distribution arrester surges varied from 10 to 350 microseconds. The character of the tail of the high-current components is the same in both direct-strokes and distribution-arrester discharge records. The times to half value for arresters in stations are shorter than for distribution arresters or direct strokes. These data are summarized in Fig. 62.

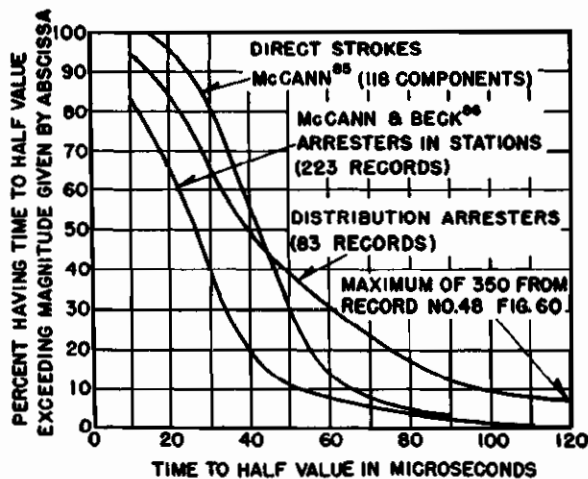

Fig. 62—Percentage distribution curves of duration of individual components of lightning-surge currents.

Similar data obtained by McEachron⁶³ by means of the cathode-ray oscillograph are summarized in Fig. 63.

Wave Fronts—The results of Stekolnikov and Valeev on direct strokes as summarized in Table 3 indicate wave fronts of from 1.5 to 10 microseconds. Fig. 64 summarizes data obtained on the Empire State Building.⁶³

Table 4 gives the results of measurements made with the magnetic surge-front recorder on direct-stroke currents, arrester discharge currents, and a transmission-line tower current.⁶⁵ These data indicate a lower limit of 0.5 and an

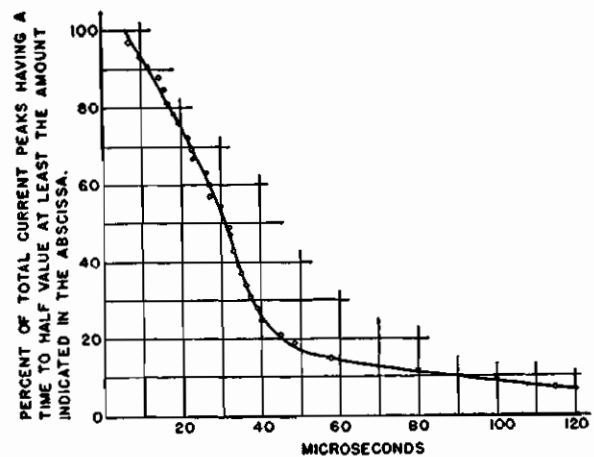

Fig. 63—Duration of current peaks measured to half-value, as a function of frequency of occurrence,⁶³ based on 11 strokes measured with cathode-ray oscillograph.

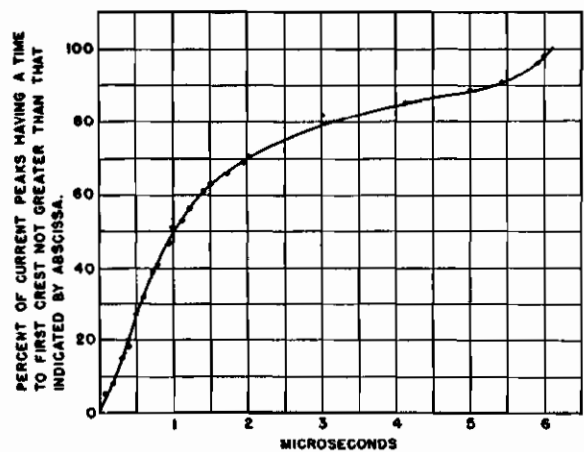

Fig. 64—Time to first crest of current peaks, as a function of frequency of occurrence,⁶³ based on cathode-ray oscillograms of 13 strokes.

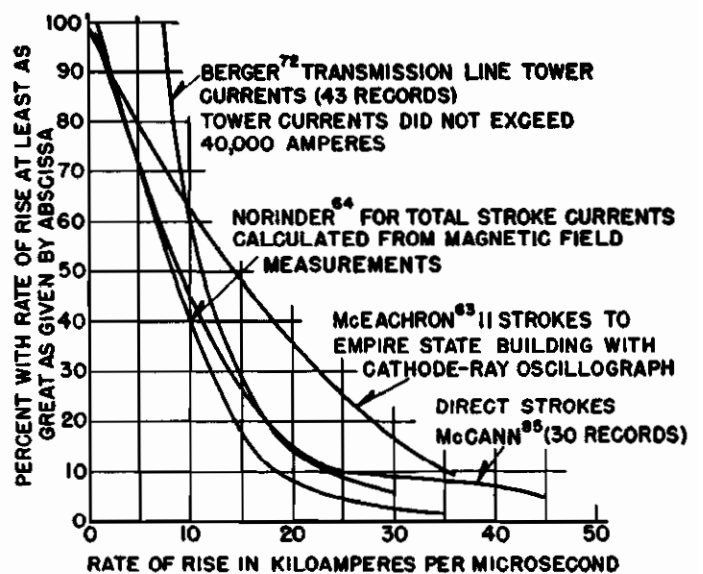

Fig. 65—Percentage distribution curves of rate of current rise on fronts of lightning surges.

TABLE 4—RECORDS OBTAINED WITH MAGNETIC SURGE-FRONT RECORDERS BY WAGNER, MCCANN, AND BECK⁶⁵

Record Number	Polarity	Crest Current, Amperes	Surge Front, Microseconds	Average Rate of Rise, Amperes Per Microsecond
Currents in direct strokes				
24	Neg.	19 000	2.5	7 600
34	Neg.	3 000- 12 500	0.5- 9.6*	1 300- 6 000*
59	Neg.	1 000- 3 300	0.5-19.0*	174- 2 000*
60	Neg.	325- 6 800	0.5- 6.0*	1 140- 2 000*
Currents in common grounds of three-phase arrester banks				
5	Neg.	100	More 10	Less 10
55	Neg.	1 600	2	800
30	Pos.	500	1	500
41	Neg.	500	1.1	450
31	Pos.	600	More 6	Less 100
42	Pos.	825	More 20	Less 40
38	Pos.	1 100	3.9	280
47	Neg.	2 300	6	380
45	Neg.	200	More 10	Less 20
58	Neg.	5 100	1.6	3 200
48	Neg.	400- 4 300	(0.5-20)*	500- 2 600*
Transmission-line tower current				
66	Neg.	50 400	1.16	43 600

*These values indicate the limits within which the true values lie due to inaccuracies introduced by multiple strokes.

upper limit of 20 microseconds. The lower limit, however, is quite doubtful because the presence of multiple strokes impaired the indication. The highest average rate of current rise measured in a direct stroke in these studies is 7600 amperes per microsecond for a stroke with a crest of 19 000 amperes. However, the transmission line tower current, which had a crest of 50 400 amperes, indicated an average rate of rise of 43 600 amperes per microsecond. The highest average rate of rise measured in an arrester discharge was 3200 amperes per microsecond for a surge with a crest current of 5100 amperes.

Fig. 65 gives percentage distribution curves on the rate of rise occurring on the front of the wave. Berger's measurements are of currents in transmission-line towers. The highest rate of rise that he recorded was between 30 000 and 40 000 amperes per microsecond. However, the crest currents associated with the records did not exceed 40 000

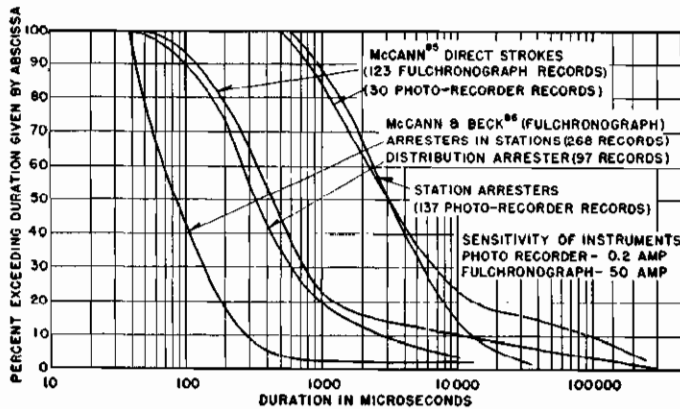

Fig. 66—Percentage distribution curves of duration of individual components of lightning-surge currents.

amperes. Norinder's values are questionable, as they were estimated from measurements made of the magnetic fields produced by lightning strokes. McEachron's data represent the effective rate of rise of strokes measured with the cathode-ray oscillograph. McCann measured with the cathode-ray oscillograph and magnetic surge-front recorder the effective rate of rise of direct strokes to tall objects.

32. Characteristics of the Long-Duration Tails

The records obtained on the long-duration portion of direct strokes indicate that their character varies over wide limits. Aside from the strokes of continuing character recorded to tall objects,^{65,71} the fulchronograms⁶⁵ of direct strokes indicate component durations of between 50 and 300 000 microseconds. The curves of Fig. 66 show the measurable duration of individual components of direct strokes as measured with the fulchronograph and also the photographic-recorder. The fulchronograph and photographic-recorder have recording sensitivities of 50 amperes and 0.2 ampere, respectively. It is of interest that for any percentage occurrence value on this figure, the duration as recorded by the fulchronograph is only a small fraction of that shown by the photographic-recorder curve. This shows that on the average the duration of current above 50 amperes in a component is only a small fraction of its total duration.

It is shown in Fig. 66 that arrester-current records have considerably less evidence of long-duration tails. Of the 268 discharge records obtained from arresters in stations, only 8 percent of the surges lasted longer than 300 microseconds. Of the 97 discharge records obtained from distribution arresters, 54 percent of the surges had durations exceeding 300 microseconds. The 137 records obtained by photographic-recorder on arresters in stations show that 50 percent of the surges lasted longer than 3000 microseconds. As shown by Bergvall and Beck²⁵ power transformers on grounded-neutral systems should be able to absorb the long-tail portion of the wave to an appreciable degree, if a sufficiently low impedance path to ground is provided. Distribution transformers should perform this function to a lesser degree. Thus, under these conditions, the arresters and transformers tend to protect each other. The arrester takes the high-current portion of the surge, which is injurious to the transformer; and the transformer the long-duration portion, which is injurious to the arrester. This is verified by the fact⁶⁵ that the 14 long-duration records were obtained on systems in which the protective value of the transformer ground connection is absent, although only about 30 percent of the arrester records were obtained on this type of circuit.

Further evidence of the influence of the system ground on surge duration is found in the field experience that has been gained in the past with a new type distribution arrester.⁶⁵ Of 27 000 arrester years of operation on four-wire systems in which the neutrals of the source transformers are grounded with the neutral brought out to the distribution transformers being protected, no failures have occurred. For systems with the source grounded but with the neutral not brought out and the primary of the protected transformer not grounded, the record shows 7 failures caused by lightning out of 8500 arrester years, or

0.082 percent. On delta systems 11 lightning failures have occurred in 4500 arrester years, giving a performance of 0.24 percent. This result can be explained only by the presence of long-duration surges.

A further significant fact is that 16 of the 18 failures occurred on four systems having only 1078 arrester years' experience. These systems, in addition to being either delta- or wye-connected with the protected transformer ungrounded, were in regions of very high soil resistivity. This indicates that strokes in regions of high soil resistivity may have longer-duration components than those in regions of low soil resistivity.

33. Conclusion

As a result of the investigations described, certain characteristics of lightning may be said to be quite definitely known. Among these are:

1. Mechanism of the discharge.
2. Polarity.
3. General wave shape.
4. Number of components in the discharge.
5. Time intervals between components of discharges.
6. Total stroke durations.
7. Crest magnitude of stroke current at ground, of tower currents, and of currents discharged by lightning arresters.

On the other hand, many questions are still only partially answered. Thus,

1. Thunderstorms appear to follow more or less definite paths as influenced by local terrain, which produces great localized variations in storm and lightning-stroke density. The only information available as to the density of strokes is that distributed by the Weather Bureau, which pertains only to the number of storm days, and is based upon aural indications. The Bureau data do not take these local conditions and line locations with regard to them into consideration.
2. Of the half-dozen proposed theories of charge formation, none explains completely all the factors involved.
3. The length of the stroke channel, that is, the height of the charge centers above earth, and the distribution of charge and current in the channels are still insufficiently known.
4. Earth resistivity and geological structure appear to influence the duration and possibly the crest magnitude of stroke discharges, but insufficient information is available to determine the extent.
5. Tall objects unquestionably affect the initial streamers and it is likely that the subsequent discharge is also affected.
6. The extent to which current at the ground flows between the individual components is still somewhat questionable.
7. The initial rates of rise of stroke currents and voltages encountered on systems are still worthy subjects of research.
8. More direct evidence is required to determine whether some of the recorded tower currents are due to induced effects.

It is apparent, therefore, that although considerable progress has been made in lightning research, many questions still remain for further investigation.

REFERENCES

1. Some Thundercloud Problems, C. T. R. Wilson, *Journal Franklin Institute*, Vol. 208, 1929, Page 1.
2. Some Investigations in the Deformation and Breaking of Water Drops in Strong Electric Fields, W. A. Macky, *Proceedings Royal Society, Series A*, Vol. 133, 1931, Page 565.
3. On the Electrical Charge Collected by Water Drops. J. P. Gott. *Proceedings Royal Society, Series A*, Vol. 151, 1935, page 665.
4. The Mechanism of a Thunderstorm, Sir George Simpson, *Proceedings Royal Society, Series A*, Vol. 114, 1927, page 376.
5. The Distribution of Electricity in Thunderclouds, Sir George Simpson and F. J. Scrase, *Proceedings Royal Society, Series A*, Number 906, Vol. 161, 1937, page 309.
6. The Distribution of Electricity in Thunderclouds—II, Sir George Simpson and G. D. Robinson, *Proceedings Royal Society, Series A*, Vol. 177, 1941, page 281.
7. On the Origin and Distribution of Thunderstorm Electricity, W. J. Humphreys, *Monthly Weather Review*, September 1939, 67:321.
8. Aircraft Lightning Discharges, E. J. Minser, *Journal of the Aeronautical Sciences*, Volume 7, Number 2, December 1939.
9. Investigations on Lightning Discharges and on the Electrical Field of Thunderstorms, C. T. R. Wilson, *Philosophical Transactions, Royal Society, Series A*, Vol. 221, 1920, page 73.
10. *Atmospheric Electricity* (book), B. F. J. Schonland, Methuen and Company, London.
11. Lightning to the Empire State Building, K. B. McEachron, *Journal Franklin Institute*, Vol. 227, Number 2, February 1939.
12. Lightning Investigation on Transmission Lines—VII, W. W. Lewis, C. M. Foust, *A.I.E.E. Transactions*, Vol. 59, 1940 (April section), page 232.
13. Progressive Lightning, B. F. J. Schonland, H. Collens, *Proceedings Royal Society, Series A*, Vol. 143, 1934, page 654.
14. Progressive Lightning—II, B. F. J. Schonland, D. J. Malan, H. Collens, *Proceedings Royal Society, Series A*, Vol. 152, 1935, page 595.
15. Progressive Lightning, III—The Line Structure of Return Lightning Strokes, D. J. Malan, H. Collens, *Proceedings Royal Society, Series A*, Vol. 162, 1937, page 175.
16. Progressive Lightning, IV—The Discharge Mechanism, B. F. J. Schonland, *Proceedings Royal Society, Series A*, Vol. 164, 1938, page 132.
17. Progressive Lightning, V—A Comparison of Photographic and Electrical Studies of the Discharge Process, B. F. J. Schonland, D. B. Hodges, H. Collens, *Proceedings Royal Society, Series A*, Vol. 166, 1938, page 56.
18. *The Lightning Discharge*, B. F. J. Schonland, Clarendon Press, Oxford, England, 1938.
19. Direct Stroke Proves Length of Lightning Tail, C. F. Wagner and Edward Beck, *Electrical World*, July 29, 1939, page 37.
20. Photographing Lightning With a Moving Camera, Alex Larsen, Annual Report Smithsonian Institute, 1905, page 119.
21. Intermittent Lightning Discharges, B. Walter, *Philosophical Magazine*, Section 7, Vol. 20, Number 137, December 1935, pages 1144-55 and 1150-1.
22. L'Étude de la Foudre dans un Laboratoire de Campagne, I. Stekolnikov and Ch. Valeev, CIGRE, 1937, Bulletin 330.
23. The Lightning Stroke; Mechanism of Discharge, K. B. McEachron and W. A. McMorris, *General Electric Review*, October 1936, page 487.
24. Lightning Strokes in Field and Laboratory, P. L. Bellaschi, *Electrical Engineering*, Vol. 58, November 1939, page 466.
25. Lightning and Lightning Protection of Distribution Systems, R. C. Bergvall and Edward Beck, *A.I.E.E. Transactions*, Vol. 59, 1940 (August section), page 442.
26. On the Nature of Atmospherics—IV, E. V. Appleton and F. W. Chapman, *Proceedings Royal Society, Series A*, Vol. 158, 1937, page 1.
27. Lightning and Other Transients on Transmission Lines, F. W. Peek, Jr., *A.I.E.E. Transactions*, Vol. 43, 1924, page 1205.
28. The Klydonograph, J. F. Peters, *Electrical World*, April 19, 1924, page 3.

29. The Klydonograph and Its Application to Surge Investigations, J. H. Cox and J. W. Legg, *A.I.E.E. Transactions*, Vol. 44, 1925, page 857.
30. The Measurement of Surge Voltages on Transmission Lines Due to Lightning, E. S. Lee and C. M. Foust, *A.I.E.E. Transactions*, Vol. 46, 1927, page 339.
31. Résultats des Mesures Effectuées au Cours Orages de 1934–1935, K. Berger, Association Suisse des Electriciens *Bulletin*, Vol. 27, Number 6, March 20, 1936, page 145.
32. Cathode-Ray Oscillograph, A. Dufour, *Comptes Rendus*, Vol. 158, 1914, page 1139.
33. The Cathode-Ray Oscillograph, H. Norinder, *A.I.E.E. Transactions*, Vol. 47, 1928, page 446.
34. A Cathode-Ray Oscillograph with Norinder Relay, O. Ackermann, *A.I.E.E. Transactions*, Vol. 49, 1930, page 285.
35. Cathode-Ray Oscillographs and Their Uses, E. S. Lee, *General Electric Review*, Vol. 31, 1928, page 404.
36. A New Type of Hot-Cathode Oscillograph and Its Application to the Automatic Recording of Lightning and Switching Surges, R. H. George, *A.I.E.E. Transactions*, Vol. 48, 1929, page 884.
37. New High-Speed Cathode-Ray Oscillograph, H. P. Kuehni and S. Ramo, *A.I.E.E. Transactions*, Vol. 56, 1937 (June Section), page 721.
38. New Instruments for Recording Lightning Currents, C. F. Wagner and G. D. McCann, *A.I.E.E. Transactions*, Vol. 59, 1940, page 1061.
39. Lightning Currents Measured, H. W. Collins, *Electrical World*, May 12, 1934.
40. Gewittermessungen der Jahr 1932 and 1933 in der Schweiz, H. Berger, Association Suisse des Electriciens *Bulletin*, April 27, 1934.
41. Die Messung von Blitzstromstaerken, H. Grunewald, *Elektrotechnische Zeitschrift*, 1934, page 505.
42. Symposium on Operation of Boulder Dam Transmission Line—Insulation and Lightning Protection, Bradley Cozzens, *A.I.E.E. Transactions*, Vol. 58, 1939 (April Section), page 140.
43. The Surge-Crest Ammeter, C. M. Foust and H. P. Kuehni, *General Electric Review*, Vol. 35, 1932, page 644.
44. The Crater-Lamp Oscillograph, W. A. McMorris, M. A. Rusher, and J. H. Hagenuth, *General Electric Review*, Vol. 37, 1934, page 514.
45. The Distribution of Thunderstorms in the United States 1904–33, W. H. Alexander, *Monthly Weather Review*, Vol. 63, 1935, page 157.
46. Discharge Currents in Distribution Arresters—II, K. B. McEachron and W. A. McMorris, *A.I.E.E. Transactions*, Vol. 57, 1938 (June Section), page 307.
47. Klydonograph Surge Investigations, J. H. Cox, P. H. McAuley, and L. G. Huggins, *A.I.E.E. Transactions*, Vol. 46, 1927, page 315.
48. Surge-Voltage Investigation on Transmission Lines, W. W. Lewis, *A.I.E.E. Transactions*, Vol. 47, 1928, page 1111.
49. Surge-Voltage Investigations on the 140-Kv System of the Consumers Power Co. During 1927, J. G. Hemstreet and J. R. Eaton, *A.I.E.E. Transactions*, Volume 47, 1928, page 1125.
50. Surge-Voltage Investigation on the 132-Kv Transmission Lines of the American Gas and Electric Company, Philip Sporn, *A.I.E.E. Transactions*, Vol. 47, 1928, page 1132.
51. Surge-Voltage Investigation on 220-Kv System of Pennsylvania Power and Light Company, N. N. Smeloff, *A.I.E.E. Transactions*, Vol. 47, 1928, page 1140.
52. Lightning Investigation on New England Power Company system, E. W. Dillard, *A.I.E.E. Transactions*, Vol. 47, 1928, page 1122.
53. Lightning on Transmission Lines, Vis. H. Rokkaku, CIGRE, 1939, Bulletin No. 321.
54. Lightning Investigation on a Wood-Pole Transmission Line, R. Pittman and J. J. Torok, *A.I.E.E. Transactions*, Vol. 50, 1931, page 568.
55. Experience With Preventive Lightning Protection on Transmission Lines, S. K. Waldorf, *A.I.E.E. Transactions*, Vol. 60, 1941 (June Section), page 249.
56. Direct Strokes, Not Induced Strokes, Chief Cause of High-Voltage-Line Flashover, C. L. Fortescue, *Electric Journal*, August 1930, page 459.
57. Lightning Measured on 4-Kv Overhead Circuits, Herman Halperin and K. B. McEachron, *A.I.E.E. Transactions*, Vol. 53, 1934, page 33.
58. Lightning on Transmission Lines, J. H. Cox and E. Beck, *A.I.E.E. Transactions*, Vol. 49, 1930, page 944.
59. Lightning Investigations of the 220-Kv System of the Pennsylvania Power and Light Company (1930), F. Bell and A. L. Price, *A.I.E.E. Transactions*, Vol. 50, 1931, page 1101.
60. Lightning Surges on Transmission Lines—Natural Lightning, W. W. Lewis and C. M. Foust, *General Electric Review*, November 1936, page 543.
61. Lightning Investigation on 220-Kv System of the Pennsylvania Power and Light Company (1928 and 1929), N. N. Smeloff and A. L. Price, *A.I.E.E. Transactions*, Vol. 49, 1930, page 895.
62. Lightning Voltages on Transmission Lines, R. H. George and J. R. Eaton, *A.I.E.E. Transactions*, Vol. 49, 1930, page 877.
63. Lightning to the Empire State Building, K. B. McEachron, *A.I.E.E. Transactions*, Vol. 60, 1941 (September Section), page 885.
64. Lightning Currents and Their Variation, H. Norinder, *Journal of the Franklin Institute*, Vol. 220, 1933, page 69.
65. Field Investigations on Lightning, C. F. Wagner, G. D. McCann, and E. Beck, *A.I.E.E. Transactions*, Vol. 60, 1941.
66. Lightning Investigations on Transmission Lines—VII, W. W. Lewis and C. M. Foust, *A.I.E.E. Transactions*, Vol. 59, 1940 (April Section), page 227.
67. Lightning Investigations on a 220-Kv System, Edgar Bell, *A.I.E.E. Transactions*, Vol. 53, 1934 (August Section), page 1184.
68. Lightning Investigations on a 220-Kv System—III, Edgar Bell, *A.I.E.E. Transactions*, Vol. 59, 1940, page 822.
69. Recherches sur les Perturbations Provoquées par les Orages et sur la Protection des Lignes Aeriennes Contre les Orages, Grunewald, CIGRE 1939, Bulletin No. 323.
70. Direct-Stroke Currents Investigation on a 154-Kv Line, Rokkaku and Katoh, *Electrotechnical Journal (Japan)*, 1938, Vol. 2, page 175.
71. Multiple Lightning Strokes—II, K. B. McEachron, *A.I.E.E. Transactions*, Vol. 57, 1938 (September Section), page 510.
72. Resultats des Mesures Effectuees au Cours des Orages de 1934–1935, Berger, Association Suisse des Electriciens *Bulletin*, Vol. 27, March 20, 1936, page 145.
73. Lightning Currents in Arresters at Stations, I. W. Gross and W. A. McMorris, *A.I.E.E. Transactions*, Vol. 59, 1940 (August section), page 417.
74. Resultats de Quatre Annees de Recherches Faites sur les Lignes Aeriennes au Sujet des Emplacements de Chutes de la Foudre et de l'Intensite des Courants dus a la Foudre, Grunewald, CIGRE 1937, Bulletin No. 316.
75. Discussion of paper listed in reference 66, R. M. Schahfer and W. H. Knutz, *A.I.E.E. Transactions*, Vol. 59, 1940 (April Section), page 233.
76. Shielding of Transmission Lines, C. F. Wagner, G. D. McCann, and G. L. MacLane, Jr., *A.I.E.E. Transactions*, Vol. 60, 1941, page 313.
77. Wave Shapes of Successive Lightning Current Peaks, K. B. McEachron, *Electrical World*, February 10, 1940.
78. Experience With Protector Tubes, E. Wisco and A. C. Monteith, *Electric Journal*, Vol. 35, 1938, pages 299–300.
79. Design, Construction, and Operation of a Lightning-Proof

- Transmission Line, E. Hansson, Edison Electric Institute Publication No. F-6.
80. Lightning Performance of 110- to 165-Kv Transmission Lines, *A.I.E.E. Transactions*, Vol. 58, 1939 (June Section), pages 294-304.
 81. Great Lakes Division of NELA 1929-30 Report of Overhead Systems Committee.
 82. 1930-31 Report of Engineering Section of NELA—Transmission Line Operating Records, 1930.
 83. Field Investigation of the Characteristics of Lightning Currents Discharged by Arresters, I. W. Gross, G. D. McCann and Edward Beck, *A.I.E.E. Paper* 42-17.
 84. Photographic Study of Lightning, J. H. Hagenguth, *A.I.E.E. Transactions*, Vol. 66, 1947, pages 577-83.
 85. The Measurement of Lightning Currents in Direct Strokes, G. D. McCann, *A.I.E.E. Transactions*, Vol. 63, 1944, pages 1157-64.
 86. Field Research on Lightning Arrester Discharges, G. D. McCann, Edward Beck, *A.I.E.E. Transactions*, Vol. 66, 1947, pages 625-29.
 87. An Eight-Year Investigation of Lightning Currents and Preventive Lightning Protection on a Transmission System, E. Hansson, S. K. Waldorf, *A.I.E.E. Transactions*, Vol. 63, 1944, pages 251-58.
 88. Lightning Investigations on 33-Kv Wood Pole Lines, F. E. Andrews, G. D. McCann, *A.I.E.E. Transactions*, Vol. 64, 1945, pages 768-77.
 89. Lightning Investigation on Transmission Lines—VIII, W. W. Lewis, C. M. Foust, *A.I.E.E. Transactions*, Vol. 64, 1945, pages 107-15.
 90. Lightning Investigation on the 25-Kv System of the West Penn System, William C. Bowen, Edward Beck, *A.I.E.E. Transactions*, Vol. 66, 1947, pages 831-36.
 91. Transmission Line Design and Performance Based on Direct Lightning Strokes, E. L. Harder, J. M. Clayton, *A.I.E.E. Technical paper* 49-111, 1949.
 92. Hydrometeorological Report No. 5—Part II, Hydrometeorological Section Office of Hydrologic Director, U.S. Weather Bureau, August 1945.

LINE DESIGN BASED UPON DIRECT STROKES

Original Author:

A. C. Monteith

Revised by:

E. L. Harder and J. M. Clayton

THE insulation requirements of transmission lines are determined by lightning and switching transients and not by the normal frequency voltage. For lines up to the highest voltages now in use, lightning disturbances resulting from direct strokes are usually a principal factor. The direct-stroke theory attributes the severe lightning disturbances on any transmission line to direct contact of the discharge with the line. Lines built in accord with this theory are shown in Fig. 1. Prior to the acceptance of the direct-stroke theory designers did not attempt to protect lines for direct strokes. They thought it highly improbable that lines would be struck directly, and, with the limited knowledge available, believed it practically impossible to cope with direct strokes. Lines were designed on the basis of induced strokes, which assumed that the charged cloud (covering the vicinity of the line) with its accompanying gradient of voltage to ground, bound a charge on the line. The discharge of the cloud to a location other than the line itself released this bound charge, which was then free to travel along the line. Tests have shown that actual gradients appearing on the line during near-by discharges are too low to account for the damage frequently done.

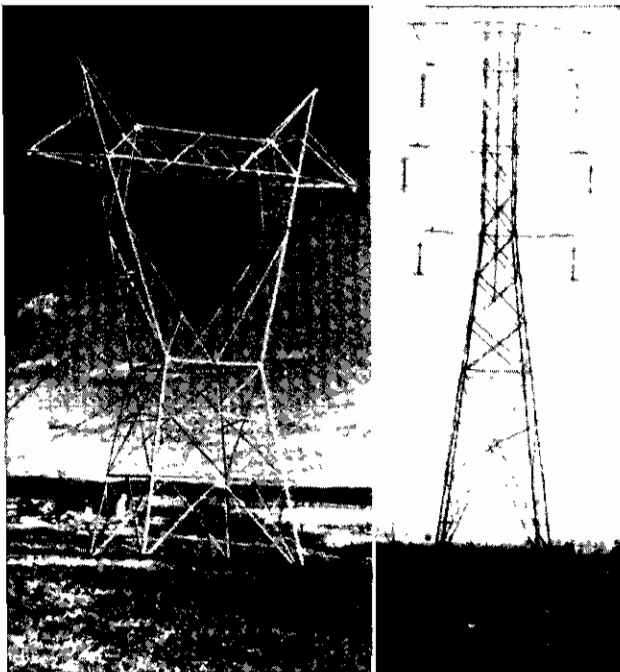

Fig. 1—These two lines were designed in accordance with the direct stroke theory of protection.

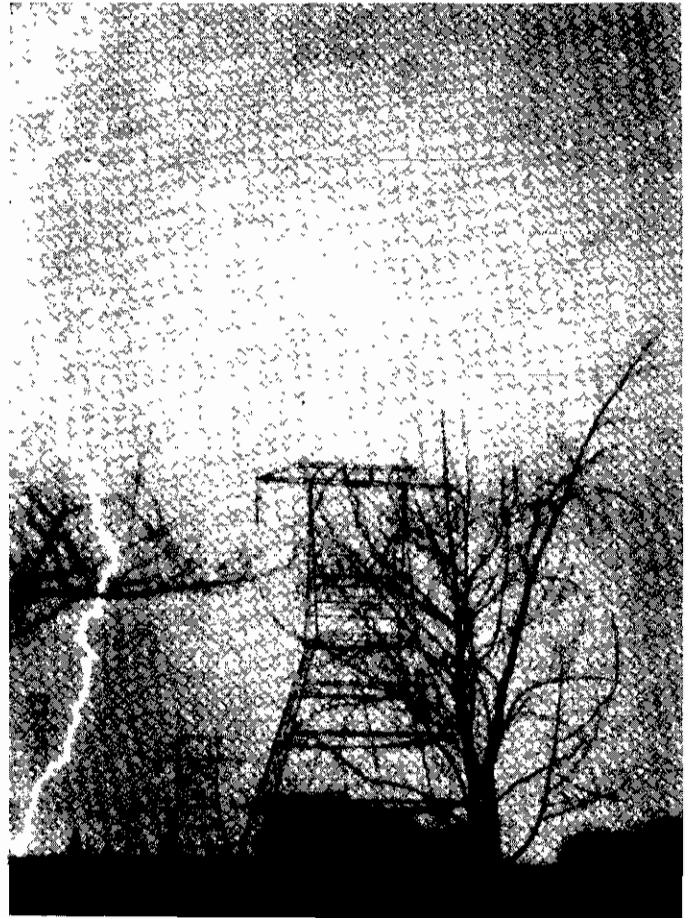

Fig. 2—Proof of the direct stroke theory—in this case the lightning struck close to the line and 1600 feet from a recording station yet no abnormal voltages were recorded.

An instance of lightning (Fig. 2) that struck earth within 1600 feet of a field measuring station and within 250 feet of a 220-kv line, without establishing any above-normal voltage on the line itself, did much to start the investigators actively to consider direct strokes as the actual menace.

Consideration was given to the effect of direct strokes and methods of combating them as early as 1929.¹ The early exponent of the theory was Dr. C. L. Fortescue. In 1930 Dr. Fortescue was sufficiently satisfied with the theory to publish an article² "Direct Strokes, Not Induced Surges Chief Cause of High-Voltage Line Flash-over," and in 1931 Fortescue and Conwell³ gave a complete discussion on the application of the direct-stroke theory to actual line design.

The direct stroke theory is now completely accepted for high-voltage lines (See App. Tables 1 and 2). Much evidence is being collected on the low-voltage rural lines to indicate that even here it is the direct stroke for which protection must be provided. More evidence must be secured for medium- and low-voltage lines to evaluate properly the possible effects of induced strokes. However, if the protection is based on the direct-stroke viewpoint, then induced strokes sink to insignificance on lines of any voltage.

Protection against direct strokes requires a shield to prevent lightning from striking the electrical conductors, together with adequate drainage facilities and adequate insulation structures so that the discharge can drain to ground without affecting the conductors. As an alternative the line can be built without shielding but rather auxiliary discharge paths provided so that any discharge tending to interfere with the flow of normal-frequency current will be interrupted. The shielding method does not allow an arc path to form from the line conductor to ground, thereby giving inherent protection in the design itself. Ground wires is one form of this type of protection. The non-shielding method or protection by auxiliary devices does allow an arc to form between the ground structure and conductors but means are provided to quench it without line interruption. De-ion protector tubes are a form of the latter type of protection.

This discussion is confined to the electrical characteristics of transmission-line design, and does not deal with the mechanical characteristics, which are adequately covered elsewhere.⁴ The discussion of the general factors to be considered in designing the two types of lightning-proof lines is intended only to give a general idea of how these factors affect the line performance. The results should not be taken as rigorous but rather should be used for considering preliminary designs on a comparative basis. The chief value of the general curves lies in the facility provided for considering alternative designs on a comparative basis; however, a check of the curves against a large amount of actual line experience does indicate good agreement.

I. LINE DESIGN—INHERENT PROTECTION

1. Design Factors

The design of a transmission line against lightning for a desired performance, is practically independent of operating voltage. The main consideration is how to obtain a protection level for the desired performance.

The basic principles underlying the design of a line based on the direct-stroke theory are:

- (1) Ground wires with sufficient mechanical strength must be located to shield the line conductors adequately from direct strokes.
- (2) Adequate clearance from the line conductor to the tower or to ground must be maintained so that the full effectiveness of the insulating structure can be obtained. (Sleet might influence this selection.⁵)
- (3) Adequate clearances from ground wires to conductors must be maintained, especially at the midspan, to prevent flashover to the conductors

up to the protective voltage level used for the line design.

- (4) Last, but equally as important, tower-footing resistances as low as are economically justified must be secured.

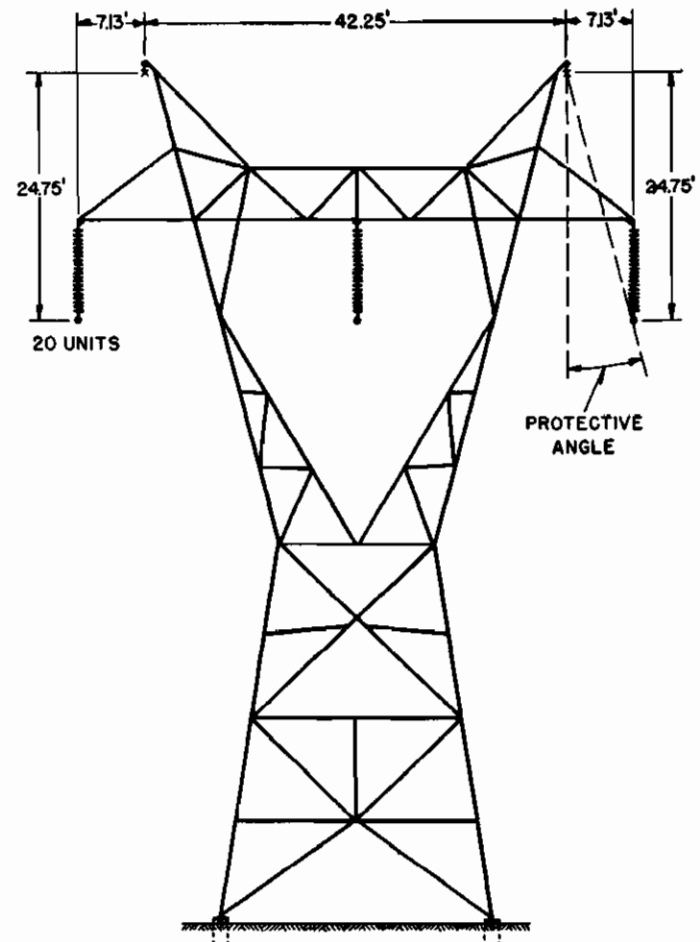

Fig. 3—Ground wire arrangements on 230-kv line.

The above points can be better visualized from Fig. 3 which shows a sketch of the ground wire arrangement for a single-circuit. The ground wires are shown placed high above the line conductors and are well out on the towers. With this type of construction the ground wires are not placed directly over the conductors. This eliminates the possibility of contact in case of dancing conductors with sleet loading and also reduces the tower-top cost. Experience with lines and also tests⁶ have shown that when the protective angle (the angle formed by a line through the ground wire and the outer phase wire and the vertical) does not exceed 30 degrees, good shielding of the line conductors is obtained, and the probability of side stroke to the conductor is slight. Data taken from many lines show that as this angle increases, the probability of flash to the conductor increases. This factor will be discussed in greater detail later.

Where the ground wires are directly connected to the supporting structures, such as to the tower top in the case of steel lines, or to the pole top with ground wires

down the poles in case of wood-pole construction, the correct location of ground wires placed high above the phase wires is a compromise with the effective utility of the insulating structure. However, unless ground wires are placed to intercept the strokes their purpose is defeated. Thus the first requisite is to correctly place the ground wires well above the conductors to prevent side flashes to the conductors. Structures on which the ground wires are not directly connected to the steel pole have been considered. For example, wood has been used to insulate the ground wires from the steel supporting structure, the ground connection to the ground wires being taken entirely free of the supporting structure. Also the erection of poles entirely separate from the conductor supporting structures and elevated high enough to shield the conductors have also been proposed. Since the design factors for arrangements of this sort are different they will be considered later. This discussion is confined entirely to lines having the ground wires directly connected to the supporting structure.

The second and third factors, the maintenance of adequate clearance from conductors to towers and from ground wires to conductors are naturally of importance in obtaining a balanced design and are discussed at length later.

The degree to which the fourth requirement—low footing resistance—can be met depends on local soil conditions. The method used to reduce the equivalent footing resistance and the degree to which this is carried is surely a matter of economics as the problem is one of balancing the cost of lowering the resistance against the cost of increased insulation and tower structure to secure the desired performance. Experience indicates that some means of reducing the footing resistance to an equivalent of ten ohms, as measured with the ground wires removed, is more economical than adding insulation. The resistivities of the principle earth materials, listed in Table 1, vary

TABLE 1—EARTH RESISTIVITY

	Meter Ohms	Foot Ohms	Centimeter Ohms
General Average.....	100	328	10,000
Sea Water.....	0.01-1.0	0.0328-3.28	1-100
Swampy Ground.....	10-100	32.8-328	1000-10 000
Dry Earth.....	1000	3280	10 ⁵
Pure Slate.....	10 ⁷	3.28×10 ⁷	10 ⁹
Sandstone.....	10 ⁸	3.28×10 ⁸	10 ¹⁰

over a considerable range so that the selection of the method of securing low tower footing resistance, will depend on local soil conditions. A more complete discussion of the use of ground rods and counterpoise will be given later.

Considerable work has been done on establishing methods⁷ for predetermining the design requirements of lines to provide a desired immunity against lightning trippouts. The curves of Fig. 4 present an estimating method⁸ which is based on the stroke current probability curve. This curve is essentially based on the data published by Waldorf⁹ except that it has been modified slightly in the high

current region to allow for strokes up to 200 000 amperes, which are known to occur from other field data. These data have been obtained through field research on a large number of lines. This estimating method treats the lightning stroke as a constant fixed current; that is, the current magnitude is assumed to be independent of the stroke terminating impedance.

The curves have been calculated on the basis that the stroke is intercepted by a shield wire. The lightning current is then expected to take the path along the shield

TABLE 2—SUMMARY OF ANACOM STUDY

Span, Feet	Tower Footing Resistance, Ohms	Tower-Top Voltage Per Ampere of Stroke Current	Mid-Span Voltage Per Ampere of Stroke Current	Time Lag to Insulate (Microseconds)	
				Tower	Midspan
200	5	11.6	27.5	2.0	2.0
	10	12.5	27.5	2.0	2.0
	20	16.3	28.5	2.0	2.0
	50	28.8	30.5	2.0	2.0
	100	45.0	40.5	2.0	2.0
400	5	13.2	45.0	2.0	2.0
	10	15.0	45.0	2.0	2.0
	20	21.0	46.5	2.0	2.0
	50	36.0	48.8	2.0	2.0
	100	57.5	56.3	2.0	2.0
600	5	14.0	65.0	2.0	2.0
	10	15.4	65.0	2.0	2.0
	20	21.5	67.5	2.0	2.0
	50	38.8	68.0	2.0	2.0
	100	64.0	72.0	2.0	2.0
800	5	14.0	86.0	2.0	2.0
	10	16.0	86.0	2.0	2.0
	20	22.0	87.5	2.0	2.0
	50	42.0	90.0	2.0	2.0
	100	72.0	92.5	2.0	2.0
1000	5	14.0	110.0	2.0	2.0
	10	17.0	110.0	2.0	2.0
	20	24.5	110.0	2.0	2.0
	50	45.0	110.0	2.0	2.0
	100	75.0	113.0	2.0	2.0
1200	5	14.0	125.0	2.0	2.0
	10	17.0	125.0	2.0	2.0
	20	24.5	125.0	2.0	2.0
	50	45.0	125.0	2.0	2.0
	100	75.0	130.0	2.4	2.0
1600	5	14.0	158.0	2.0	2.0
	10	17.0	158.0	2.0	2.0
	20	24.5	158.0	2.0	2.0
	50	45.0	158.0	3.2	2.0
	100	75.0	158.0	3.2	2.0
2000	5	14.0	167.0	2.0	2.0
	10	17.0	167.0	2.0	2.0
	20	24.5	167.0	2.0	2.0
	50	45.0	167.0	4.0	2.0
	100	75.0	167.0	4.0	2.0

Tower Flashovers

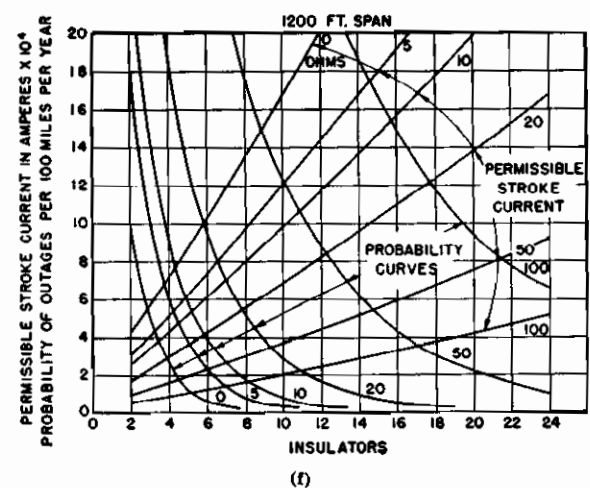
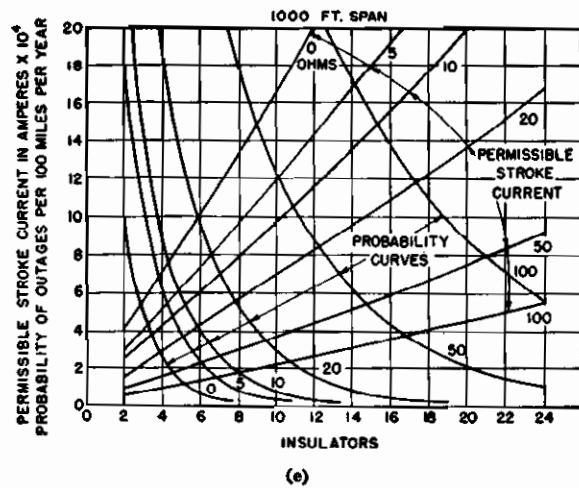
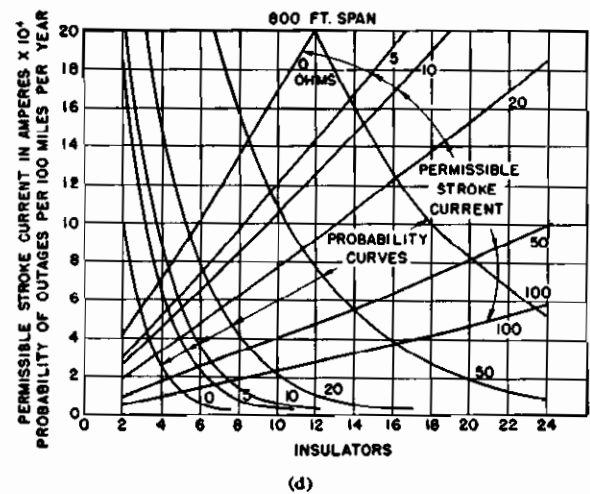
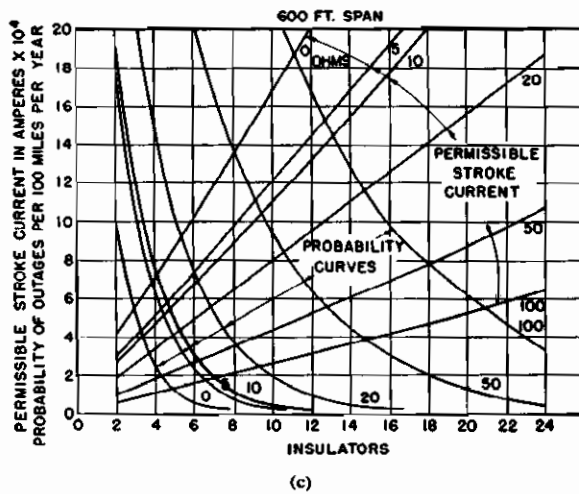
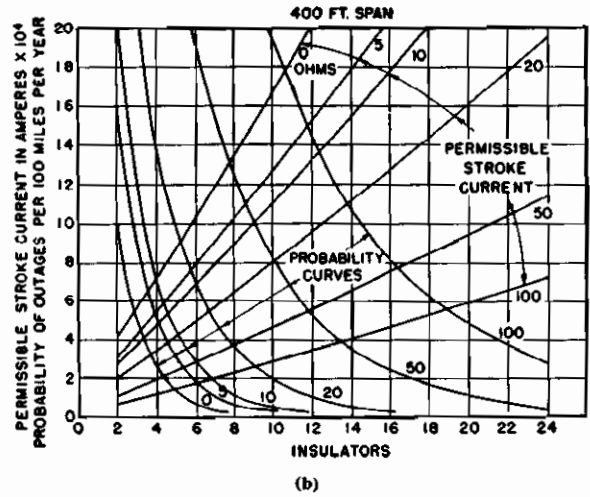
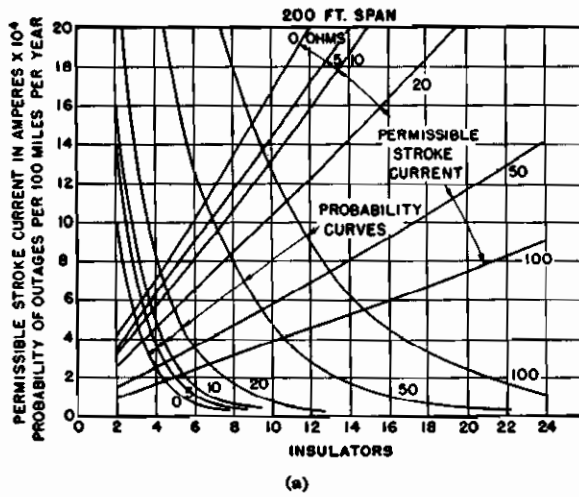
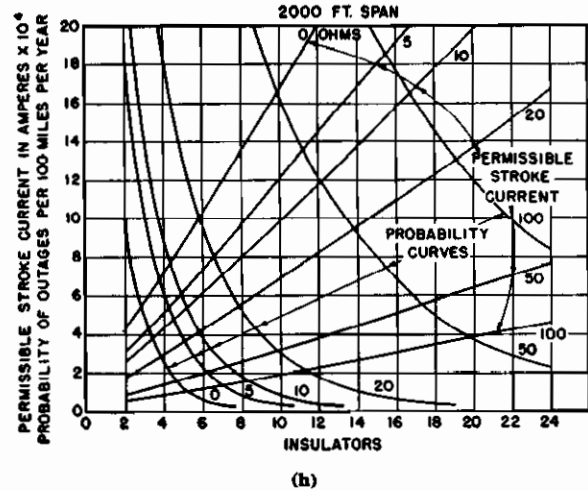
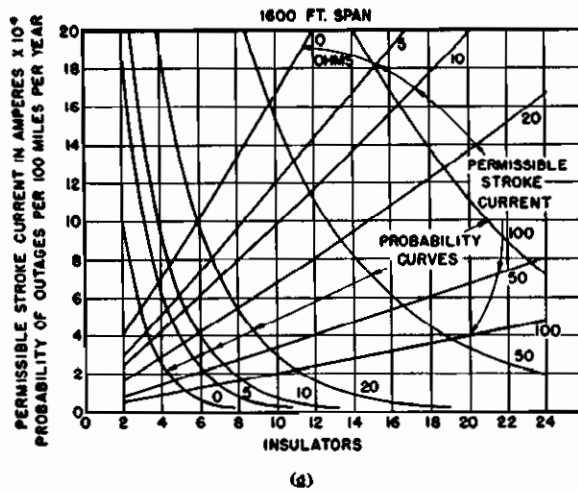

Figure 4—Continued on Next Page

Tower Flashovers



Midspan Flashovers

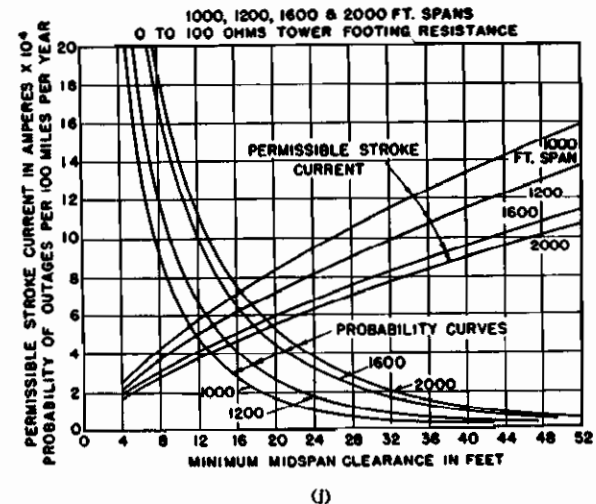
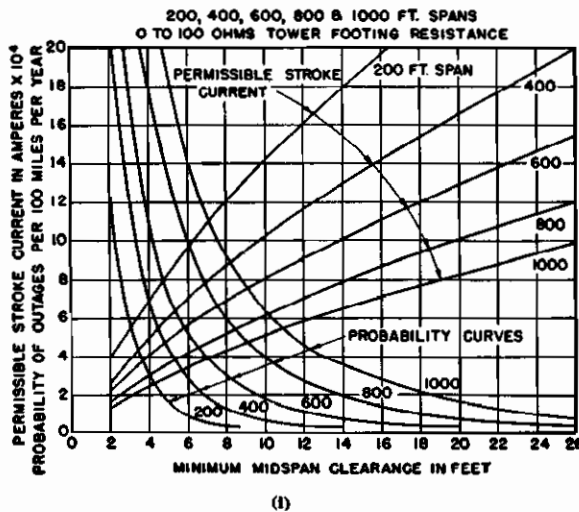

Fig. 4—Curves for estimating line insulation and performance, based on 10-inch, 5³/₄-inch spaced suspension insulators, or equivalent, and an isokeraunic level of 30 atorm days per year.

The numerals on curves (a) to (h) indicate tower footing resistance, (i) and (j) length of span.

wire, down the tower or towers, and through the tower-footing resistance to ground. As the current follows this path to ground, a transient voltage appears across the line insulation. Neglecting normal-frequency voltage, the magnitude of this voltage depends chiefly on the stroke current magnitude and wave shape, tower-footing resistance, tower inductance, span length, and coupling factor. Assuming the voltage across the insulation has been determined for a particular set of parameters, the insulation requirements can be determined from the characteristic curves of Fig. 5.

The curves of Fig. 4 are based on tower-top and midspan potentials, which were determined from a study on the Anacom.¹⁰ A typical line was set up on the Anacom and using a typical current wave, stroke currents were applied at tower-top and midspan and the corresponding

potentials measured. A 2×40 microsecond current wave was used throughout the study as representative of lightning strokes to transmission lines. Tower-top and midspan potentials were determined for the range of span lengths and footing resistances covered by the curves of Fig. 4. Some typical voltage solutions are shown in Fig. 6 and the complete results of the study are summarized in Table 2. Using these solutions and taking coupling into account the insulation requirement for any particular value of stroke current to tower can be determined from the following relationship.

$$\text{Insulation strength} = \text{stroke current} \times \text{tower-top voltage per ampere of stroke current} \times (\text{one} - \text{coupling}).$$

For this insulation strength the required number of insu-

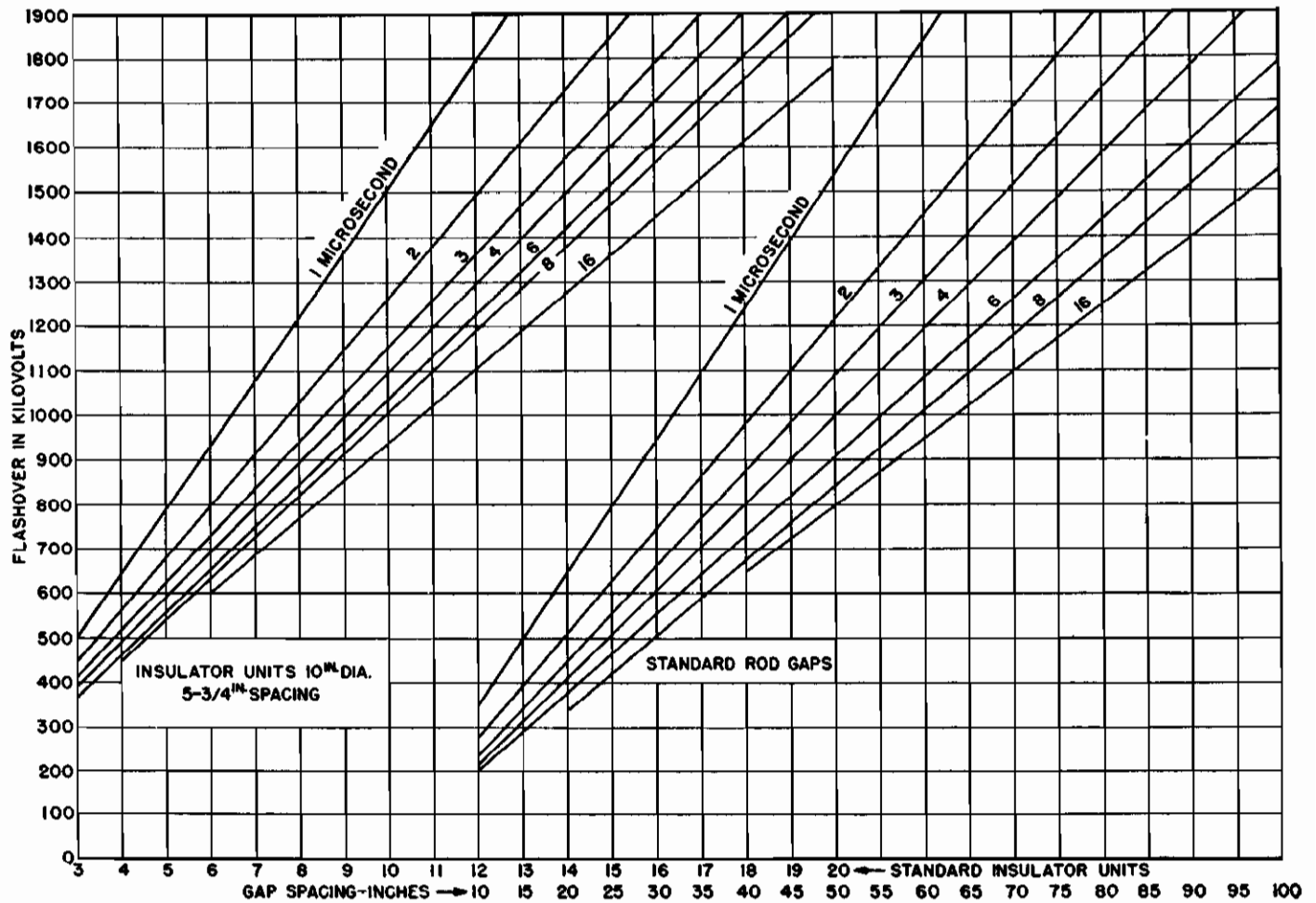

Fig. 5—Characteristics of insulators and gaps, all values are based on 1½×40 positive waves and corrected to standard atmospheric conditions.

lators was determined from the characteristic curves of Fig. 5. Note that the time lag curve to use is determined from the Anacom solutions. For example, the 3.2-microsecond time-lag curve is used in determining the tower insulation requirements for a line with 1600-foot spans and 100 ohms tower-footing resistance, Fig. 6(d). This is the time at which the tower-top potential is reduced appreciably by reflected waves from adjacent towers.

Midspan insulation requirements for strokes to midspan were determined from the results of the Anacom study in a similar manner. The Anacom study and basis of the parameters used in the study are described in detail in reference 8.

Thus, using the method outlined above, the tower and midspan insulation requirements were determined for various span lengths and tower-footing resistances and plotted as the permissible stroke current curves of Fig. 4. The probability of flashover can be determined by combining these curves with the stroke current probability curve. The magnitude of the stroke current is recognized as a matter of probability. Thus, the probability of flashover for a given case is simply the probability of stroke current in excess of that required to cause flashover. The stroke current probability curve is given in Fig. 7. The

combination of the permissible stroke current curves of Fig. 4 and the probability curve of Fig. 7 results in the general probability curves of Fig. 4.

The probability curves give line performance on the basis that all strokes are to tower, or all to midspan, respectively. Thus, line performance is determined by averaging the two outage probabilities obtained from the tower and midspan curves, respectively. For a co-ordinated line, having equal outage probabilities at tower and at midspan, either curve gives the total outages per 100 miles of line per year.

The result of reducing the tower-footing resistance is shown in Fig. 4. For example, a line designed for 10 insulators with 400-foot span and 100-ohm footing resistance, would have a protection level of 28 000 amperes stroke-current maximum. Further, the same line with 20-ohm footing resistance would have a protection level of 80 000 amperes and with 5 ohms, a level of 126 000 amperes maximum. Thus, lowering the footing resistance increases the utility of a given string of insulators. The protection level can further be increased by the addition of insulators with corresponding increase in clearances. A line designed with two insulators and a footing resistance of 10 ohms would have a protection level of approximately 28 000

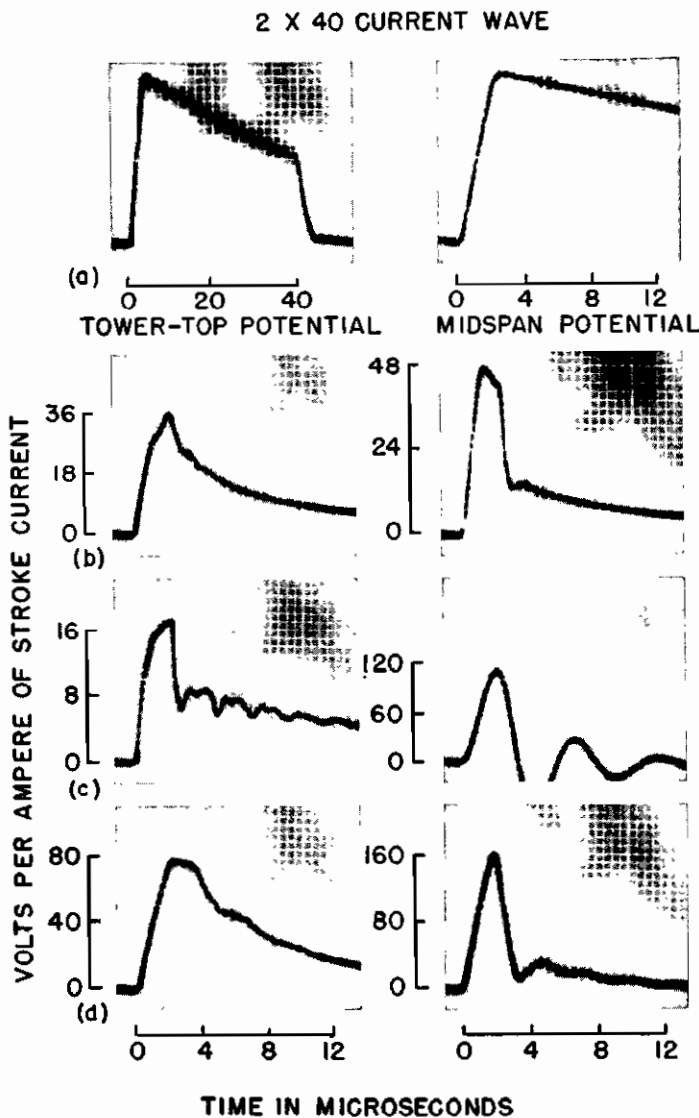

Fig. 6—Typical current wave and tower-top and midspan potentials from Anacom study.

- (a) 2×40 microsecond current wave;
- (b) 400-foot span, 50 ohm tower footing resistance;
- (c) 1000-foot span, 10 ohm tower footing resistance;
- (d) 1600-foot span, 100 ohm tower footing resistance

amperes while 7 and 11 insulators would have protection levels of 80 000 and 122 000 amperes maximum, respectively, according to Fig. 4(b). These curves for different span lengths provide a method of making estimates for different numbers of insulators and different footing resistances, facilitating the selection of the most economical design of a transmission line to meet the service requirements.

The second factor—adequate clearance from conductor to the tower can readily be obtained by providing an air-gap distance equivalent to the number of insulators. Although flashover curves of gaps and insulators have been published they are given in Fig. 5 for convenience in arriving at equivalents between insulators and gaps in air. This air distance plus the distance allowed for the swing

of the conductor by the wind will then determine the clearance from the conductor to the tower for the conductor in the normal position. The spacing between conductors can be determined by the method given above, the proper allowance being made for the supporting structures. The only insulation requirement from an operating point of view is that the 60-cycle flashover of the insulation or clearances must be of the order of four times the operating voltage to neutral. If this requirement is satisfied the probability of outage from switching surges will be negligible and then the lightning consideration will prevail. Table 3 shows the number of insulators necessary to satisfy this requirement for various operating voltages.

TABLE 3—MINIMUM SUSPENSION INSULATORS TO PREVENT OUTAGES FROM SWITCHING SURGES

Voltage Class Kv.	Maximum Expected Switching Surge—Kv	Number of Insulators
	$4 \times \frac{\text{Voltage Class} \times \sqrt{2}}{\sqrt{3}}$	
69	225	4
115	375	5
138	445	6
161	520	7
230	745	10
287	930	13
345	1120	15

The third requirement, midspan clearance, requires more consideration. On modern lines midspan clearances normally required for icing and shielding considerations and for mechanical reasons provide a high level of protection. For example, the midspan clearances required to provide the relatively high protection level of 100 000 amperes for 400-, 600-, 800- and 1000-foot spans are 9.7, 13.8, 19.8, and 26 feet, respectively, according to Fig. 4(i). These clearances closely approximate the average values usually encountered on modern lines.

In general, midspan protection levels are higher than tower protection levels, and in some cases midspan protection levels are extremely high with the results that midspan flashovers become negligible. In the previous example of a line designed with 400-foot span, 10 insulators, and with 100-, 20-, and 5-ohm footing resistances, the minimum midspan clearances should be at least 2.3, 7.0 and 12.5 feet, respectively, to be insulated for the same stroke current at midspan as at tower. However, a line with 400-foot spans normally has a midspan clearance of approximately 10 feet irrespective of footing resistance. This clearance provides a protection level of 102 000 amperes; a comparable protection level at tower requires 12-ohm footing resistance. For higher values of footing resistance, it is desirable to maintain the high midspan protection level since this results in better line performance. In some cases it may be desirable to raise the midspan protection level. This can be accomplished by increasing the midspan clearance by allowing the ground wires to sag less than the conductors.

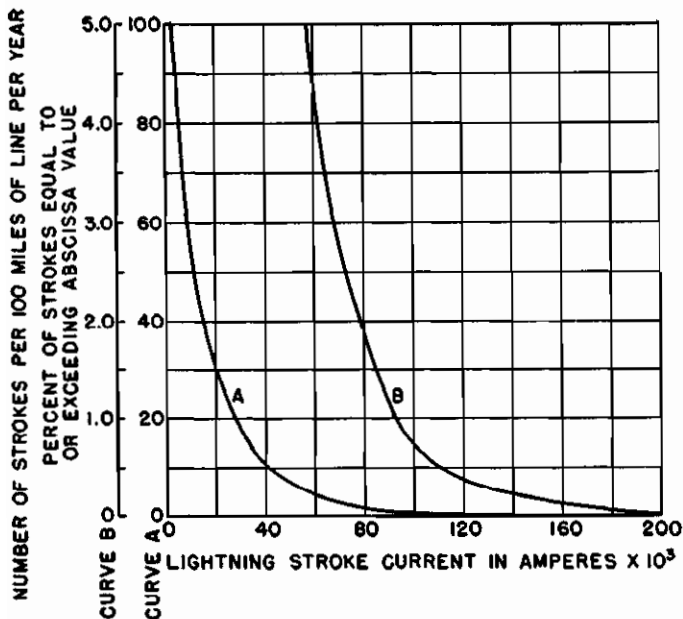

Fig. 7—Lightning stroke current probability curve. Strokes per 100 miles of line per year based on isokeraunic level of 30.

2. Design for Given Performance

This discussion has been based entirely on securing estimates for a given protection level. The question arises as to the level that should be secured for a given standard of service. The probability of flashover for a given protection level can be determined from the stroke current probability curve of Fig. 7, which is based on an isokeraunic level of 30 storm days per year.

For example, a transmission line with a protection level for 100 000 amperes stroke current maximum has an expected probability factor of 0.7 outage per 100 miles per year for an isokeraunic level of 30, and twice that, or 1.4 for an isokeraunic level of 60. Also a transmission

line designed for a protection level of 20 000 amperes stroke current maximum has a probability of 30 outages per 100 miles per year for an isokeraunic level of 30. In other words, the probability of having outages on a line decreases as the protection level increases, because the probability of experiencing strokes in excess of the higher level is not so great.

Adding insulators or reducing tower-footing resistances result in an increased protection level. There is an economic limit to which this increase in protection level can be carried. Little is gained in performance of the line by raising the protection level beyond a certain limit. For example, on a line designed with 8 insulators and 50, 20, or 5 ohms footing resistance the expected probability of outage is 15.6, 4.1, and 0.8 outages per 100 miles per year, respectively. With 12 insulators the expected performance is 7.8, 1.0, and 0.2 outages per 100 miles per year. These values assume equal protection levels at tower and midspan. Therefore, for the higher footing resistances considerably better performance can be expected from increased insulation, up to a certain limit. However, for the lower footing resistance not much is gained from increased insulation. If 5 ohms can be obtained, little return can be expected from any increase over 11 insulators, but for 20 ohms the desirable number of insulators is increased to 17 to obtain the same outage probability.

The probability curves of Figs. 4 and 7 are based on an isokeraunic level of 30 storm days per year. An isokeraunic map^{11,12} for the United States is shown in Fig. 8. The probability of outage is assumed to vary directly with the number of storm days so that if an area has 45 storm days per year from the map, the outage probability should be multiplied by 1.5.

The curves of Fig. 4 for estimating outages due to strokes to tower are based on coupling factors corresponding to a ground wire 100 feet above the ground plane and a 30-foot separation between ground wire and conductor. For other values of ground wire height and separation,

the number of insulators should be corrected to allow for the corresponding change in coupling factor; the correction factors are given in Fig. 9. The equivalent number of insulators to use with the curves of Fig. 4 is obtained by multiplying the actual number of insulators by the correction factor corresponding to the actual ground wire height and spacing. The spacing between ground wire and conductor refers to the distance to the conductor with the greatest transient voltage across its insulator string. This is the conductor most distant from the ground wire, since the coupling between this conductor and ground wire is less than the coupling for the closer conductors.

On some lines the midspan protection level may be more than twice the tower protection level with

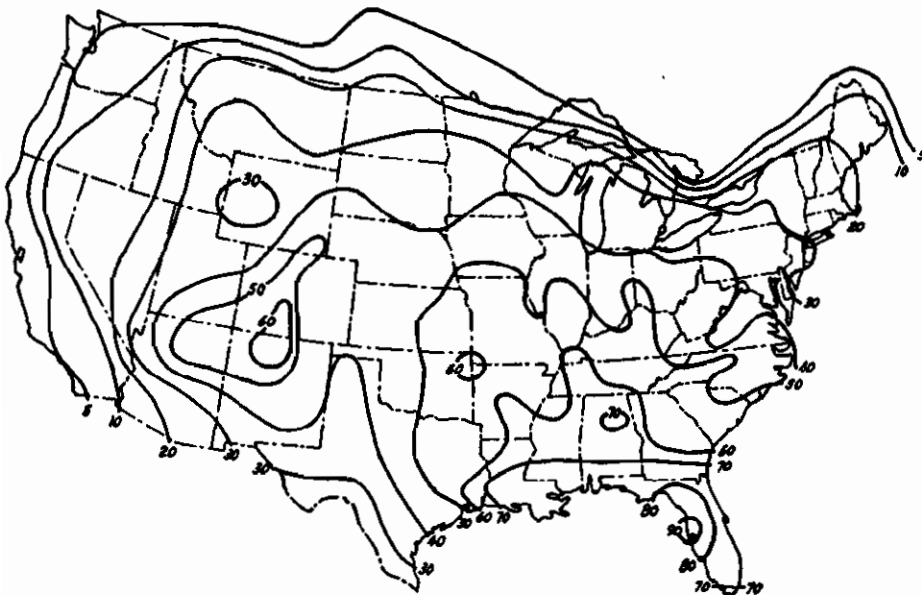

Fig. 8—Annual isokeraunic map of the United States showing number of thunderstorm days per year.

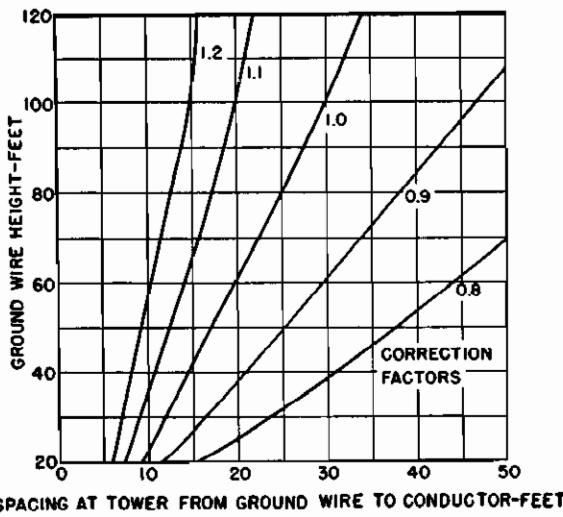

Fig. 9—Correction factors for ground wire height and ground wire-to-conductor spacing at tower.

the result that strokes to midspan may cause flashover at tower rather than at midspan. If the permissible stroke current to midspan is more than twice the permissible stroke current to tower, the outage probability is the average of that corresponding to the permissible stroke current to tower and that corresponding to twice this stroke current. If the permissible stroke current curves of Fig. 4 indicate the midspan protection level is more than twice the tower protection level, the outage probability should be determined from the curve of Fig. 10.

On wood-pole lines where the insulating medium may be a combination of porcelain, wood, and air, the insulation strength of the flashover path must be determined and converted to an equivalent number of standard insulators. The insulation strengths of standard insulators and air can be determined from Fig. 5, and the insulation

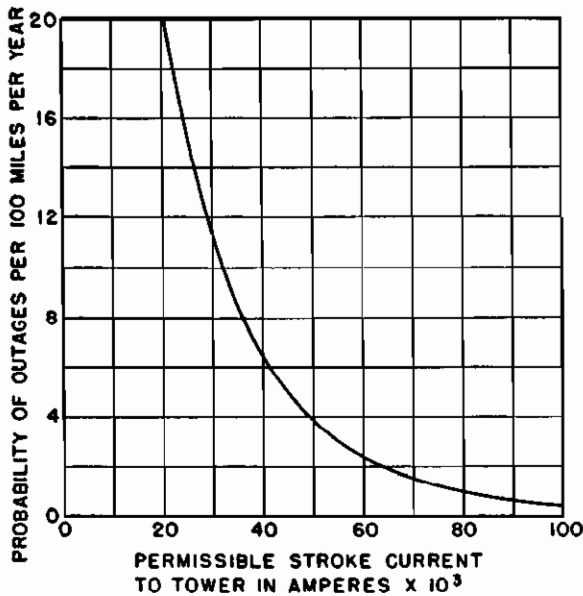

Fig. 10—Curve for determining the outage probability if the midspan protection level is more than twice the tower protection level.

strength of wood in series with the insulator string can be determined from Fig. 11.¹³ For estimating purposes the flashover voltages of the different insulating media can be added and the equivalent number of insulators for the total flashover voltage can be determined from Fig. 5. In making these calculations all flashover voltages should be based on the two microsecond time lag curves.

The general curves are based on all flashovers causing power follow and consequently outages; however, all

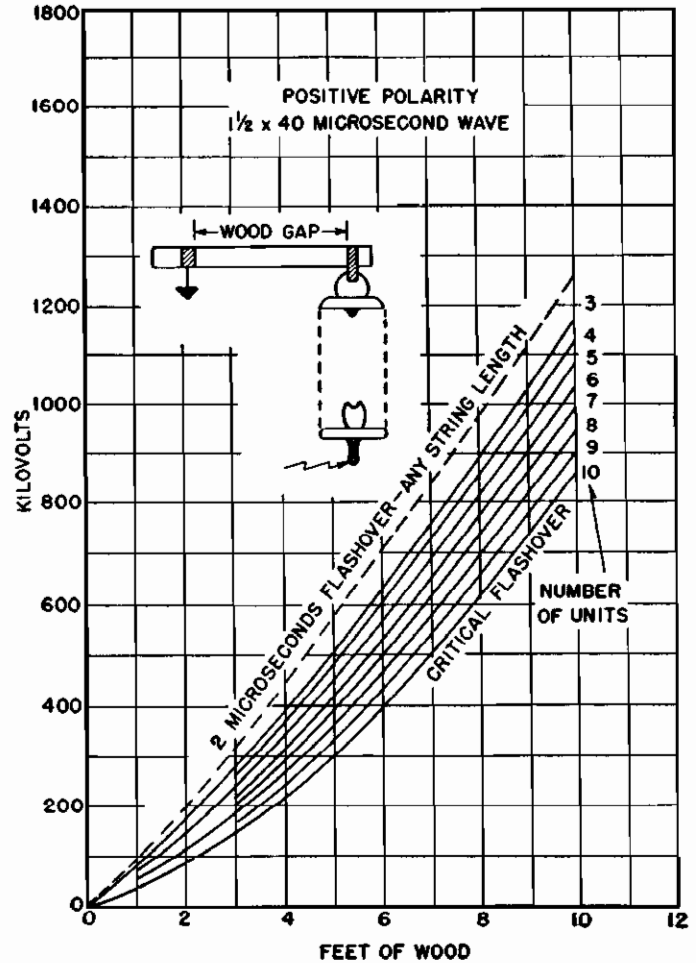

Fig. 11—Impulse insulation added to suspension-insulator strings by wood crossarms.

flashovers do not result in outages depending on the line insulation characteristics and other factors. The ratio of outage to flashover is discussed in section III.

3. Application of Curves

The use of the curves of Fig. 4 in estimating line performance is illustrated by a few examples.

Example 1. A proposed 138-kv line is to have not more than 2 outages per 100 miles per year based on an iso-keraunic level of 30. Shielding the line is recognized as desirable. Soil conditions are such that the footing resistance is 100 ohms. Tests show that four 30-foot ground rods reduce the resistance to 50 ohms; that a partial counterpoise reduces this to 20 ohms equivalent, and that an adequate counterpoise reduces it to 10 ohms equivalent.

The first question is span length. The topography of the country, conductor size, etc., must be considered. However, assume that all factors have been considered and 1000-foot spans have been selected and that ground wires and conductors will be sagged to permit a midspan separation of 24 feet. The outage probability for this midspan separation is 1.0, Fig. 4(i). Therefore, the outage

TABLE 4—MINIMUM CLEARANCE FROM CONDUCTOR TO TOWER

Tower Footing Resistance Ohms	Number of Insulators	Clearance Inches
100	27	155
50	18	105
20	10	59
10	7	43

probability for strokes to tower must be 3.0 so that the average of the tower and midspan outages will be 2.0. For three outages per 100 miles per year and 100-ohms footing resistance, 27 insulators are required, Fig. 4(e). The number of insulators becomes 18 for 50 ohms, 10 for 20 ohms, and 7 for 10 ohms footing resistance. The minimum conductor-to-tower clearance, balanced against the insulator flashover, is given in Table 4. These dimensions allow a layout of the towers; and the added cost of towers, insulators, etc., can be balanced against the cost of reducing the footing resistance.

Example 2. Determine the outage probability of a 69-kv steel-tower line, shielded by overhead ground wire, located in an area where the isokeraunic level is 50, which has eight 5 $\frac{3}{4}$ -inch spaced suspension insulators per string. The average span is 600 feet with a midspan separation of 16 feet. The average tower-footing resistance is 50 ohms.

From the probability curves, Fig. 4(c), the outage probability for strokes to tower corresponding to eight insulators and 50 ohms tower-footing resistance is 13.7 per 100 miles per year and the permissible stroke current is 35 000 amperes. From Fig. 4(i) the outage probability for strokes to midspan corresponding to the given span length and separation is 0.5 per 100 miles per year, and the permissible stroke current is 110 000 amperes. Since the permissible stroke current to midspan is more than twice the permissible stroke current to tower, strokes to midspan can cause flashovers and consequently outages at the tower. For this case the outage probability is determined from Fig. 10. The outage probability for a permissible stroke current to tower of 35 000 amperes is 8.5 per 100 miles per year for an isokeraunic level of 30. The corresponding outage probability for an isokeraunic level of 50 is $50/30 \times 8.5 = 14.2$ per 100 miles per year.

Example 3. Determine the outage probability based on an isokeraunic level of 30 of a 69-kv wood-pole line having six standard insulators and an average pole-grounding resistance of 50 ohms. The average span is 600 feet with a 14-foot midspan separation. The line insulation consists of six feet of wood in the electrical circuit in addition to the six insulators. The spacing between ground wire and conductors is 12 feet at the poles and the ground wire is 50 feet above the ground plane.

The equivalent insulation of the wood and porcelain based on the two microsecond time-lag curves can be determined from Figs. 5 and 11. The flashover voltages for six insulators and six feet of wood are 800 kv and 700 kv, respectively. From Fig. 5 the sum of these values, 1500 kv, is equivalent to 12 standard insulators.

The increased coupling due to spacing and ground wire height can be taken into account by the correction factors of Fig. 9; a correction factor of 1.1 corresponds to a 12-foot separation and ground wire height of 50 feet. Correcting for coupling the equivalent insulation becomes $1.1 \times 12 = 13.2$ insulators.

From Figs. 4(c) and 4(i) the outage probabilities corresponding to 13.2 insulators, 50 ohms pole-grounding resistance, and 14 foot midspan separation are 5.0 and 0.7 per 100 miles per year for strokes to tower and midspan, respectively. The average of these, $(5.0 + 0.7)/2 = 2.85$, is the outage probability for the line assuming all flashovers result in sustained power follow and trip-out. Since part of the insulating medium is wood, approximately 50 percent of the flashovers will result in outages. Thus the outage probability is $0.50 \times 2.85 = 1.42$ per 100 miles per year.

II. PERFORMANCE OF TYPICAL LINES

The general curves of Fig. 4 express line performance in terms of four main parameters; namely, footing resistance, line insulation, midspan clearance, and span length. Tower footing resistance and line insulation requirements are usually determined by the standard of service that is required of the line. Midspan clearance and span length affect line performance but are determined largely by other factors. Midspan clearances normally required for mechanical reasons provide adequate protection against midspan flashovers. The length of span is determined primarily by the conductor size and tower construction. The selection of towers and conductors depends primarily on the voltage class of the line; thus, average values of midspan clearance and span length are representative of a large percentage of the lines in a particular voltage class. Using average values for these parameters, line performance of a typical line in a particular voltage class can be expressed in terms of two parameters—footing resistance and line insulation. On this basis the curves of Figs. 12 and 13 present a method for estimating the performance of typical lines of voltage classes ranging from 34.5 to 287.5 kv. Three curves are given for each voltage class which cover the range of insulators normally encountered, the center curve being based on the number of insulators most common for the voltage class.

The curves are calculated on the basis that probability of flashover is independent of the normal frequency voltage. Therefore, the application of the curves is not restricted to the indicated voltage class. For example, a 69-kv line may be under consideration with span length and midspan separation which are approximately equal to the values on which the 115-kv estimating curves are based. In this case the 115-kv curves are used in estimating performance of a 69-kv line, provided the desired line insulation level is also covered by the curves.

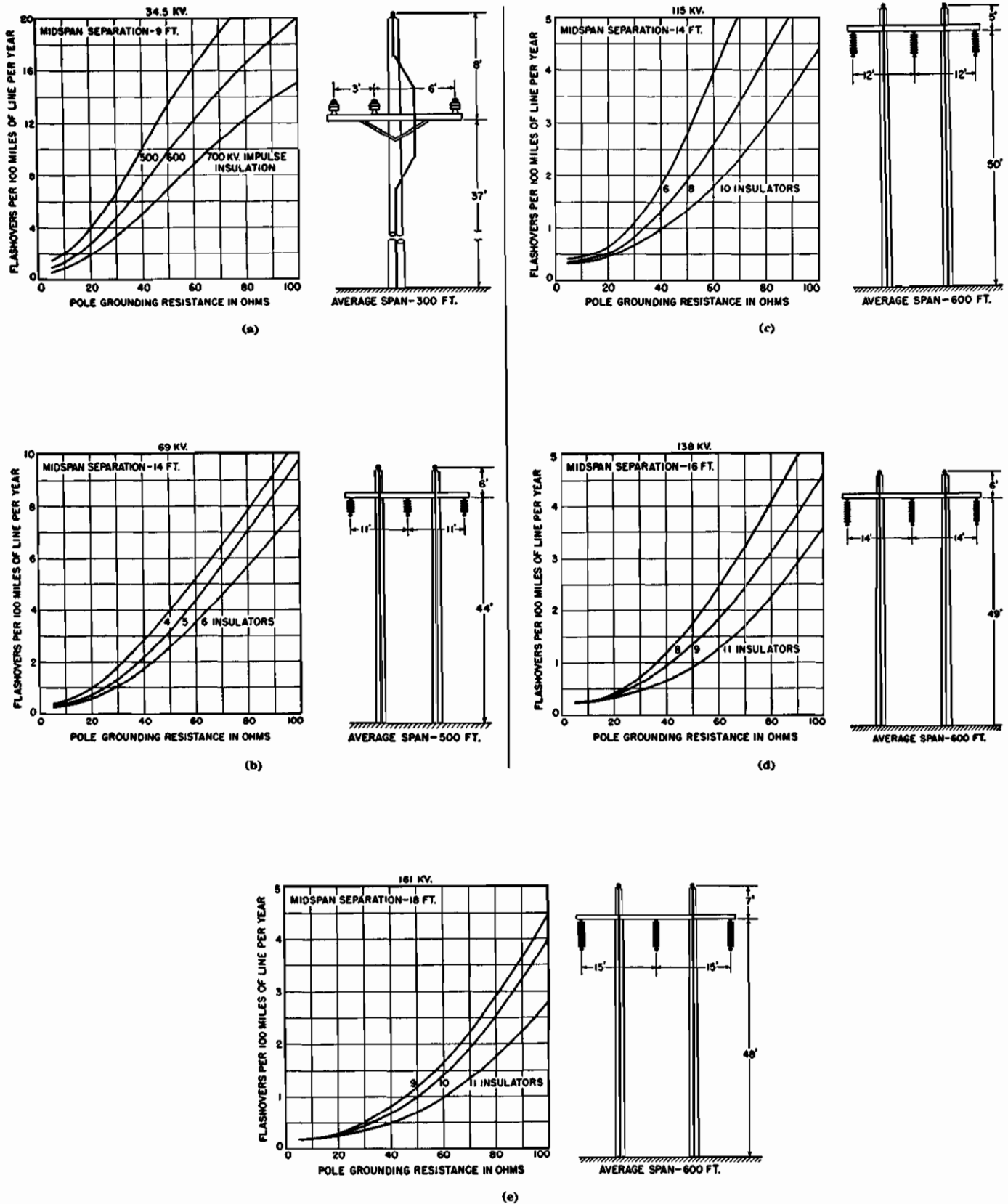
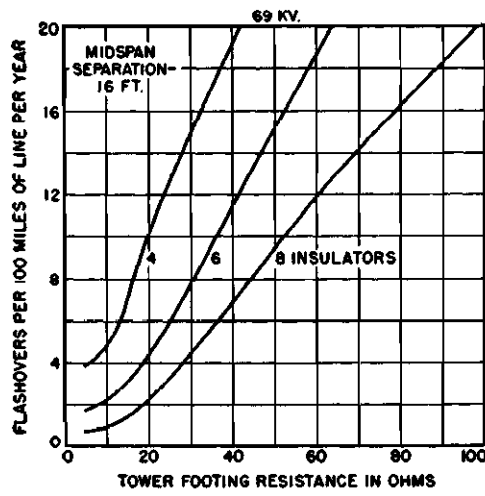
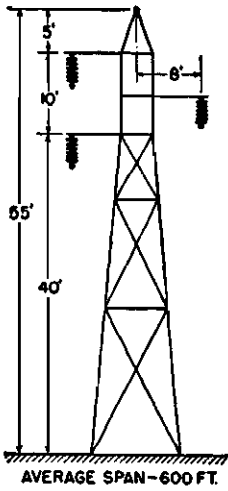
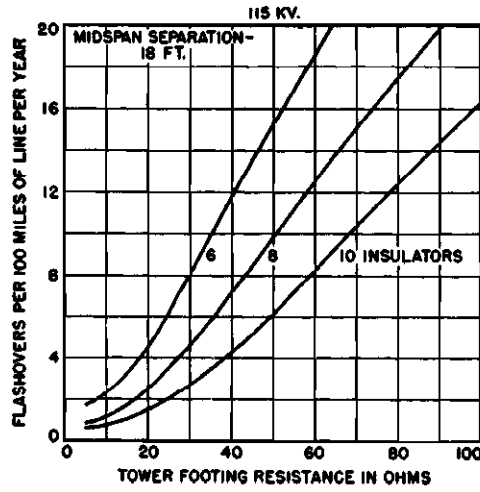
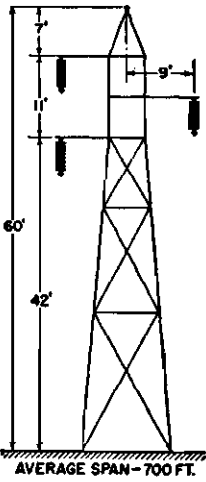
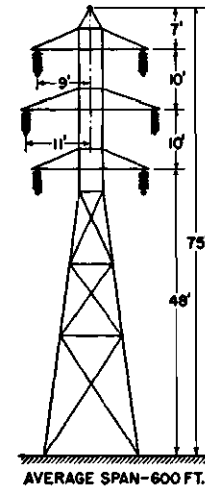

Fig. 12—Typical configurations of wood-pole lines and curves for estimating line performance based on standard insulators and an iskeraunic level of 30 storm days per year.



(a)



(b)

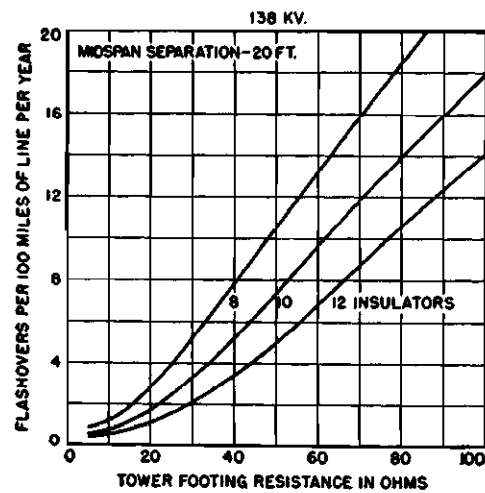
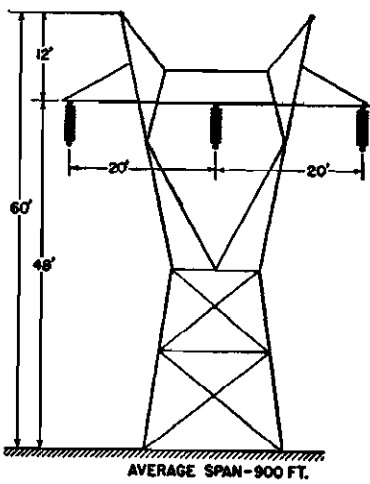
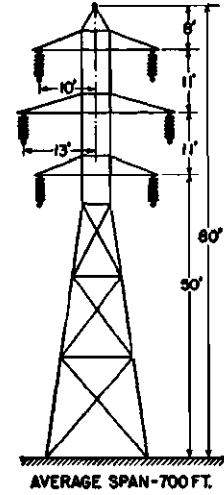

(c)

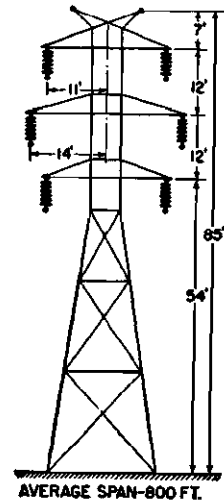
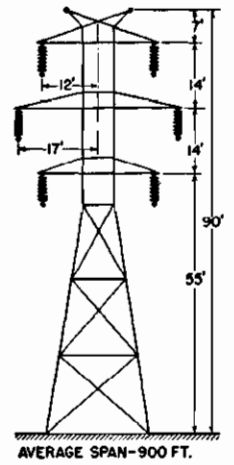
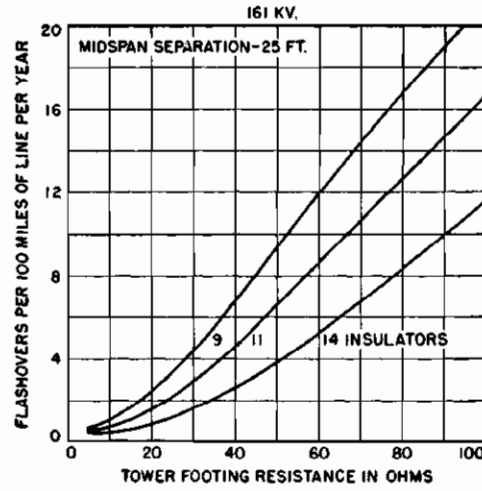
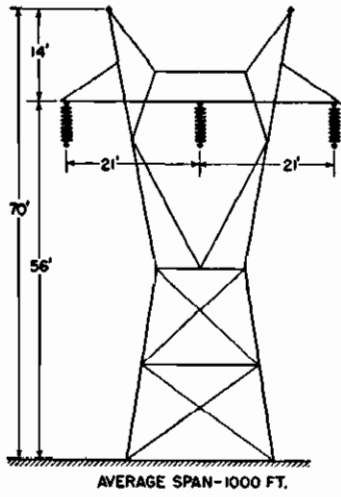
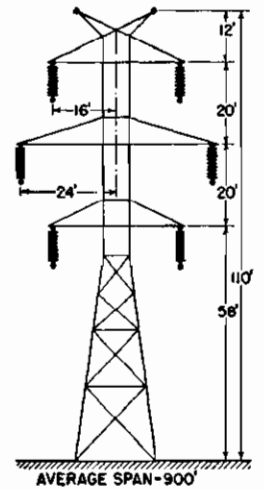
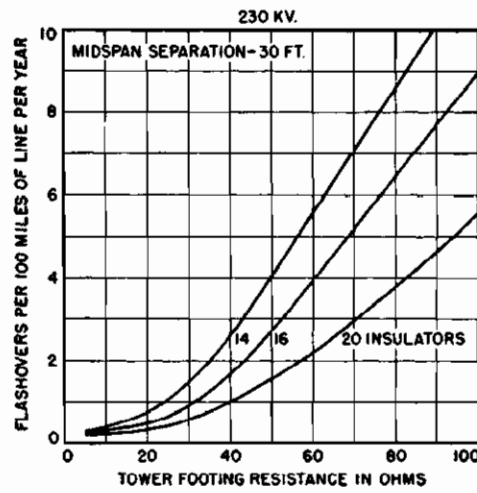
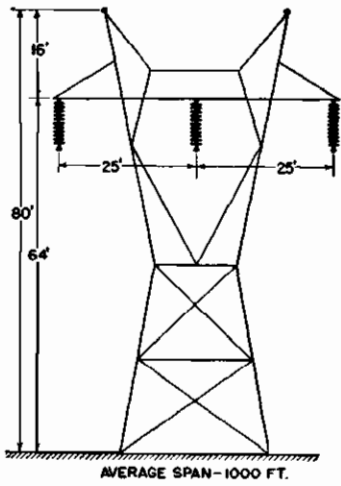

Fig. 13—Continued on Next Page.



(d)



(e)

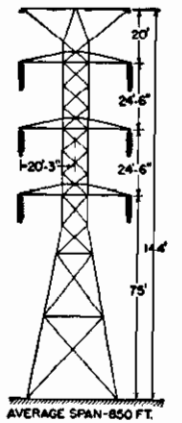
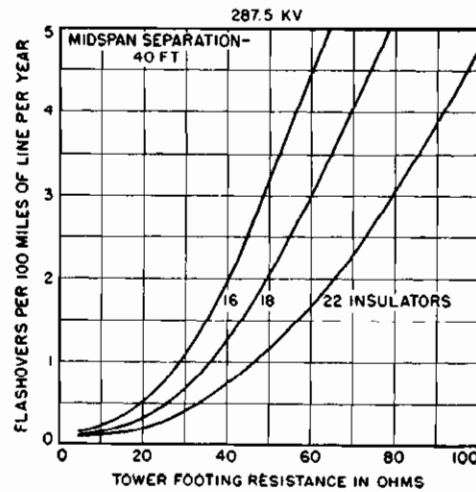
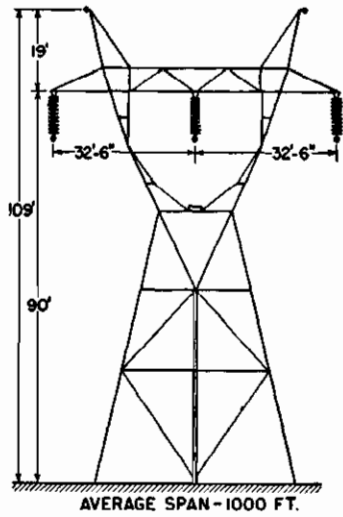

(f)

Fig. 13—Typical configurations of steel-tower lines and curves for estimating line performance based on standard insulators and an iskeraunic level of 30 storm days per year.

The average values of span lengths and midspan separations used in calculating the curves are shown in Figs. 12 and 13. In general, small variations in these factors do not affect the number of flashovers appreciably. For example, a 115-kv line with eight insulators, 800-foot spans, 18-foot midspan separation, and 10 ohms tower-footing resistance has a flashover probability of 1.2 per 100 miles per year. As the span length is increased to 1000 feet or decreased to 600 feet, the corresponding flashover probability becomes 1.35 or 1.1 per 100 miles per year. Assuming the midspan separation is increased to 22 feet or decreased to 14 feet the corresponding flashover probability becomes 1.0 or 1.65 per 100 miles per year. Thus, small variations in the midspan clearance and span length do not affect the outage probability appreciably. If the span length and midspan separation of a particular line under consideration are appreciably different from the values on which the curves are based, the line performance should be determined from the curves of Fig. 4.

The curves of Figs. 12 and 13 give the number of lightning flashovers rather than the number of line outages; all flashovers do not result in line outages. The ratio of outage to flashover which is discussed in section III depends on the line and line insulation characteristics of the particular line being considered.

4. Performance of Wood-Pole Lines

The curves of Fig. 12 for estimating the performance of wood-pole lines are based on the typical conductor and ground wire configurations shown in the same figure; these configurations are averages of several lines. In calculating the number of flashovers at poles, the path of

TABLE 5—GENERAL DATA ON WOOD-POLE LINES

Nominal Voltage (KV)	Number of Insulators*	Impulse Insulation Level** (1½×40 Positive Waves)	60-Cycle Dry Flashover ¹ (KV-RMS)	Times Normal Line-Ground Voltage
34.5	Pintype	500	120	6.0
		600	180	9.0
		700
69	4	970	270	6.8
	5	1020	330	8.3
	6	1070	380	9.5
115	6	1130	380	5.7
	8	1220	500	7.5
	10	1330	600	9.0
138	8	1330	500	6.3
	9	1380	550	6.9
	11	1490	660	8.3
161	9	1450	550	5.9
	10	1490	600	6.5
	12	1600	710	7.6

*Middle value shows the most common number; upper and low values show the range for modern lines of this voltage class.

**Based on number of insulators shown in previous column plus the length of wood in electrical circuit shown in Fig. 12.

¹ Based on porcelain insulation only.

minimum impulse insulation is assumed to be the porcelain plus the wood in the electrical circuit. The length of wood in the electrical circuit is assumed to be half the distance between phase conductors, the distance between conductors being shown in Fig. 12. The ground wire down-lead is assumed to be fastened directly to the pole. In some cases the line insulation is increased by mounting the down-lead away from the pole so that an air gap is included in the flashover path in addition to the porcelain and wood. General data on wood-pole lines are summarized in Table 5.

5. Performance of Steel-Tower Lines

Curves for estimating the performance of typical steel-tower lines are presented in Fig. 13; typical conductor and ground wire configurations for single-circuit and double-circuit lines are included in this figure. General data on steel-tower lines are summarized in Table 6. Spans for

TABLE 6—GENERAL DATA ON STEEL-TOWER LINES

Nominal Voltage (KV)	No. of Insulators*	Impulse Insulation Level (1½×40 Positive Waves)	60-Cycle Dry Flashover (KV-RMS)	Times Normal Line-Ground Voltage
69	4	430	270	6.8
	6	600	380	9.5
	8	760	500	12.5
115	6	600	380	5.7
	8	760	500	7.5
	10	930	600	9.0
138	8	760	500	6.3
	10	930	600	7.5
	12	1100	710	8.9
161	9	850	550	5.9
	11	1020	660	7.1
	14	1270	820	8.8
230	14	1270	820	6.2
	16	1440	930	7.0
	20	1780	1140	8.6
287.5	16	1440	930	5.6
	18	1610	1030	6.2
	22	1950	1250	7.5
345**	18	1610	1030	5.2
	20	1780	1140	5.7
	24	2110	1350	6.8

*Middle value shows the most common number; upper and lower values show the range for modern lines of this voltage class.

**No existing lines of this voltage class today.

single-circuit lines are generally about 100 feet longer than double-circuit lines in the same voltage class. Other factors remaining equal, the outage probability is slightly greater for the line with longer spans. However, coupling factors are usually less on double-circuit lines due to the greater separation between ground wires and conductors, and this increases the outage probability slightly, other factors remaining equal. Thus, the performance of single-

circuit and double-circuit lines can be expressed without appreciable error in a single set of estimating curves.

The curves for estimating flashovers on 287.5-kv lines are not based on the actual number of insulators used on the only existing line of this voltage class. The curves are based on a range of insulator values so that line performance can be determined for various insulation levels. Also, the curves covering the upper insulation levels can be used for estimating line performance of higher voltage lines that may be constructed in the future.

III. DETAILED DISCUSSION OF FACTORS

6. Ground Wires

The selection of the size, arrangement, and mechanical strength of ground wires is of paramount importance in the design of a line. Some of the earlier troubles with ground wires (sometimes called "static" wires) have been traced to mechanical difficulties or incorrect selection of the material. Sleet sometimes causes ground wires to come in contact with the conductors, producing line outage. This is minimized as ground wires with characteristics practically the same as the conductors are used. The proper location and tension is discussed at length in a published paper.⁵

When a ground wire is selected with the above thoughts in mind the size is more or less fixed. A small increase of diameter affects the protection slightly but the increased cost does not warrant carrying this very far. Usually more improvement is obtained by spending this same money to improve other factors. The material should be non-corrosive. Practically all wire manufacturers now have available a suitable high-strength, non-corrosive wire. Calculations indicate a small improvement in coupling by increasing the ground wire size. A reduction of tower-footing resistance gives the same effect in the final design and is much cheaper. It is therefore seen that the selection of the ground wires should be based on mechanical rather than electrical considerations.

The experience with properly selected and arranged ground wires has been satisfactory, some lines now being practically lightning-proof.

7. Protective Angle

The necessary protective angle between a line through the vertical of the tower and a line through the ground wire and outermost line conductor has been a much discussed subject. Experience with various lines indicated that 20 degrees was giving entire satisfaction but how much higher this angle could be made was open to question. Some lines with 45 degrees were giving poor results.

Laboratory tests,⁶ coordinated with field results on existing lines indicate that a good average for this angle is 30 degrees. In arriving at this conclusion models were erected in the laboratory and by using different scales with different locations of ground wire and electrode simulating the cloud it was concluded that 45 degrees for this angle should be satisfactory when the line was on the level. However, it is found that when the tower is erected on a hillside the angle should be decreased by the angle of the

slope of the hill. A study of actual lines¹⁴ shows this to be the case.

Tests and experience show that 30 degrees is a good average; however, the shielding angle can be worked out in detail with the curves of Fig. 14. These curves show

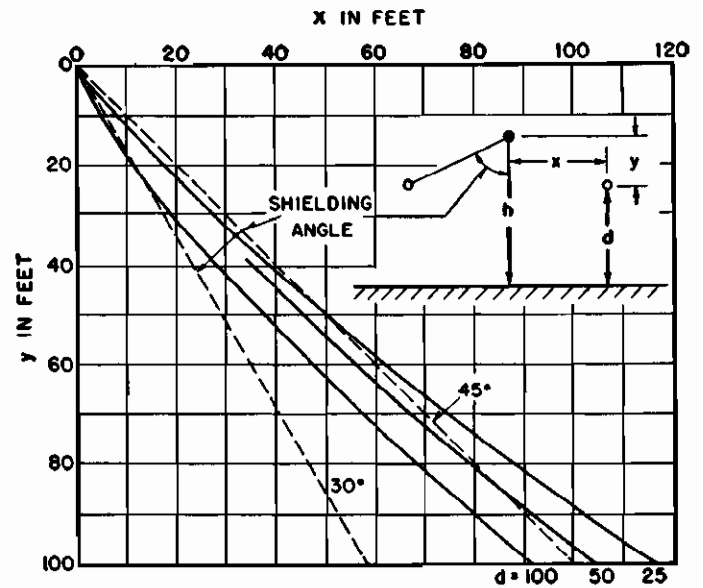

Fig. 14—Ground wire and conductor configurations for 0.1 percent exposure of conductors.

ground wire and conductor configurations that permit 0.1-percent exposure of the conductors. The general curves of Fig. 4 assume that all strokes are intercepted by the shield wire. If the phase conductors are not completely shielded, the outage probability is determined by adding directly the estimated number of strokes terminating on the conductors to the outage probability given by the curves.

8. Coupling

The entire ground wire or tower-top voltage does not appear across the line insulation since a voltage of the same polarity as the ground wire voltage is induced on the conductors. The ratio of this induced voltage on the conductor to the ground wire voltage is the coupling factor. Thus, the voltage across the line insulation is the ground wire voltages times (one - coupling factor), neglecting normal frequency voltage.

The electromagnetic and electrostatic coupling factors are equal unless the effective radius of the ground wire is increased by corona, then the electrostatic coupling increases and the electromagnetic coupling is believed to be unaffected. The coupling factor with corona considered is calculated by the equation, coupling

$$= \sqrt{\text{electrostatic coupling} \times \text{electromagnetic coupling}}$$
 Coupling is calculated by the equation,

$$C = \frac{\log b/a}{\log \frac{2h}{r}}$$

where

- C = coupling factor.
 a = distance from conductor to ground wire.
 b = distance from conductor to image* of ground wire.
 h = height of ground wire above ground.
 r = radius of ground wire.

The electromagnetic coupling factor is calculated using the actual radius of the ground wire, and the electrostatic coupling factor is calculated by the same equation using the effective radius¹⁵ of the ground wire due to corona.

9. Lightning Flashover and Power Follow

All lightning flashovers do not result in sustained power follow. The percentage of flashovers that result in power follow depends principally upon the type and length of the insulation path, the magnitude of the power follow current, and the magnitude and duration of the lightning flashover current. Performance records on various types of lines have yielded some data¹⁶ on the ratio of sustained power follow to flashover.

For the higher voltage, steel-tower lines where the principal flashover path is in air or over porcelain, about 85 percent of all lightning flashovers result in sustained power follow if the line length is less than 100 miles. The ratio is reduced to about 0.50 for such lines over 200 miles in length. For wood-pole lines where part of the flashover path is over wood, the ratio of power follow to flashover ranges from 0.35 to 0.50. For 13- and 33-kv wood-pole lines Ekvall¹⁷ shows the sustained power follow to be a function of the length of flashover path over wood divided by the normal frequency voltage.

If the characteristics of the line and line insulation result in a considerable reduction of the ratio of power follow to flashover, this should be considered in estimating the outage probability. To determine the outage probability taking this factor into account, multiply the ratio of power follow to flashover by the outage probability from the general curves. If the ratio is near unity, it can be neglected and the general curves will indicate a slightly pessimistic outage probability.

10. Tower-Footing Resistance

Tower-footing resistance is usually expressed as the measured 60-cycle value; however, line performance depends on the impulse value of the footing resistance. The value of the impulse resistance depends on a number of factors such as soil resistivity, critical breakdown gradient of the soil, magnitude of the surge current, and length and type of driven grounds or counterpoises. If long or continuous counterpoises are used because the soil resistivity is high, the initial impulse resistance is the surge impedance of the counterpoise, which is usually greater than the 60-cycle resistance. Counterpoises are discussed in the following section.

In soils of low or medium resistivity, adequate grounding can usually be obtained by driven ground rods. For these grounds the impulse resistance is usually less than the 60-cycle value. The ratio of impulse to 60-cycle re-

*The image of a wire is the same distance below the ground surface that the wire is above the ground surface.

sistance depends on the characteristics of the driven grounds, which are determined largely by soil resistivity and the critical gradient at which the soil breaks down. A number of laboratory tests^{18,19} have been made on driven grounds to determine the impulse characteristics under various conditions. The impulse resistances of various grounds for impulse currents ranging up to 12 000 amperes are shown in Fig. 15. For grounding resistances in

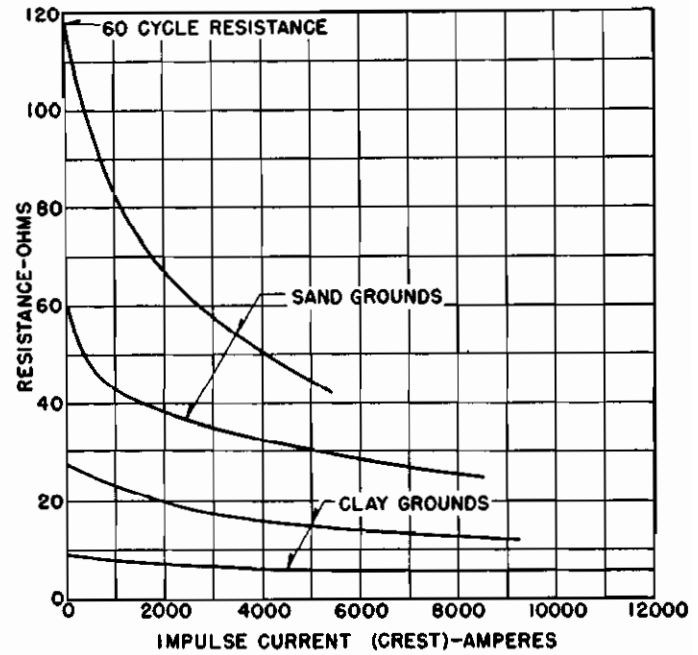

Fig. 15—Variation of impulse resistance with impulse current for various values of 60-cycle resistance.

the order of 10 ohms or less, the impulse resistance is only slightly less than the 60-cycle value; however, for high ground resistances the impulse resistance is considerably less than the 60-cycle value. Thus, in estimating line performance footing resistances of ten ohms or less can be taken as the impulse value; however, if the footing resistance is high, the impulse resistance should be determined and used in the general curves of Fig. 4. Values of impulse resistance can be worked out in detail with references 18 and 19.

11. Lowering Tower-Footing Impedance (Rods and Counterpoise)

The discussion on the design factors indicates the desirability of reducing the tower-footing impedance as much as economically possible. The steel tower naturally has a large surface in contact with the soil, particularly that type of tower with the grillage type footing or earth anchor. The methods of calculating the tower-footing resistance and the effect of surface have been worked out.²⁰ This work shows the effectiveness of contact of the tower and counterpoise with the soil. If the tower inherent construction does not naturally give a resistance to ground low enough for an economical design the grounds can be improved by driving rods in and around the tower footing either during or following erection of the line. A practical example of this is shown in Table 7.

TABLE 7—TOWER GROUND RESISTANCES, OHMS

Tower	Test of Ground Res.		30 ft. Driven Ground Rod Res. of Rod Ground at				Test of Tower Ground Res. 30 ft. Rod Connected
	March 4	April 18	15 ft.	20 ft.	25 ft.	30 ft.	
	513	24.16	13.7	48	35	25	
520	27.0	17.2	84	37.5	25	21	9.8
521	24.0	13.9	108	67	38	31.8	11.33
550	22.26	16.5	69	39	27	27	11.1
551	20.96	16.0	80	45	32	31	11.5

Chemical treatment of ground has been considered, but this has not been a satisfactory method for actual line design, it being used more for substation grounds. The curves of Fig. 16 show that the size of ground rod does not influence the resistance materially whereas the length is most influential. For this reason it is better either to use small but long rods or many small rods. The curves of Fig. 16 provide a method of estimating the number of rods necessary to reduce the tower-footing resistance to a

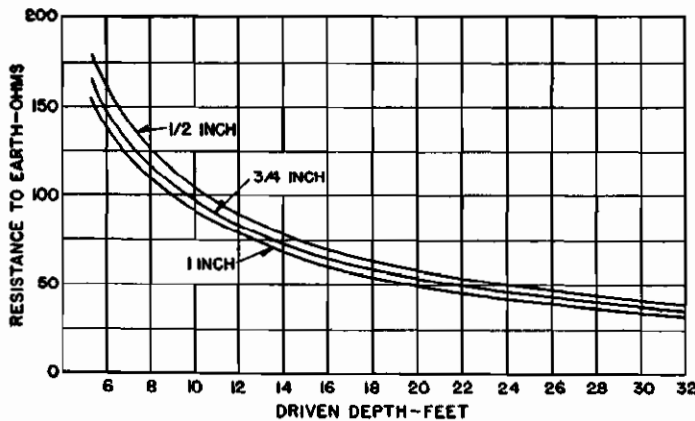

Fig. 16—Resistance to earth of driven rods for three different diameters and a specific resistance $\rho = 1000$ foot ohms.

Curves taken from H. B. Dwight "Calculation of Resistances to Ground," *A.I.E.E. Transactions*, December, 1936.

$$R = \frac{\rho}{2\pi L} \left(\log_e \frac{4L}{a} - 1 \right) \text{ where } L = \text{length in cm. and } a = \text{radius of rod in cm.}$$

specific magnitude provided the resistivity of the soil is known. These are based on resistivity of 1000 foot ohms. For other resistivities the curve can be varied directly in proportion to the changed resistivity. The curves of Fig. 17 show the effect of increased number of rods for different spacings.

The counterpoise is a practical means of reducing the resistance by increased area of earth in contact with the grounding system. This is nothing more than a conductor buried in the ground, it being run parallel to or at some angle to the line conductors themselves. The parallel counterpoise as compared to one at right angles gives a little more coupling with the line conductor. This increase in itself is so small that it need not be considered in the calculation but rather taken as an additional factor of safety. At the most this could be ten percent but usually it is less than five percent. If possible a parallel

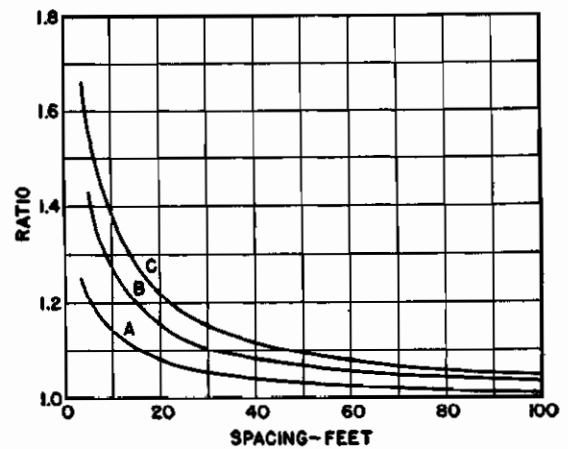

Fig. 17—Ratio of resistance of ground rods in parallel to that of isolated rods.

A—two rods, B—three rods, C—four rods.

Ground rods are $\frac{3}{4}$ inch diameter, 10 feet deep; 3 rods on equilateral triangle, 4 rods on square.

Taken from H. B. Dwight paper "Calculation of Resistance to Ground."

counterpoise should be used and advantage taken of it. This should not, however, be allowed to dictate, as leakage resistance and initial surge impedance are more important factors in selecting a successful counterpoise.

A wire or counterpoise buried has an initial surge impedance depending somewhat on soil conditions but this

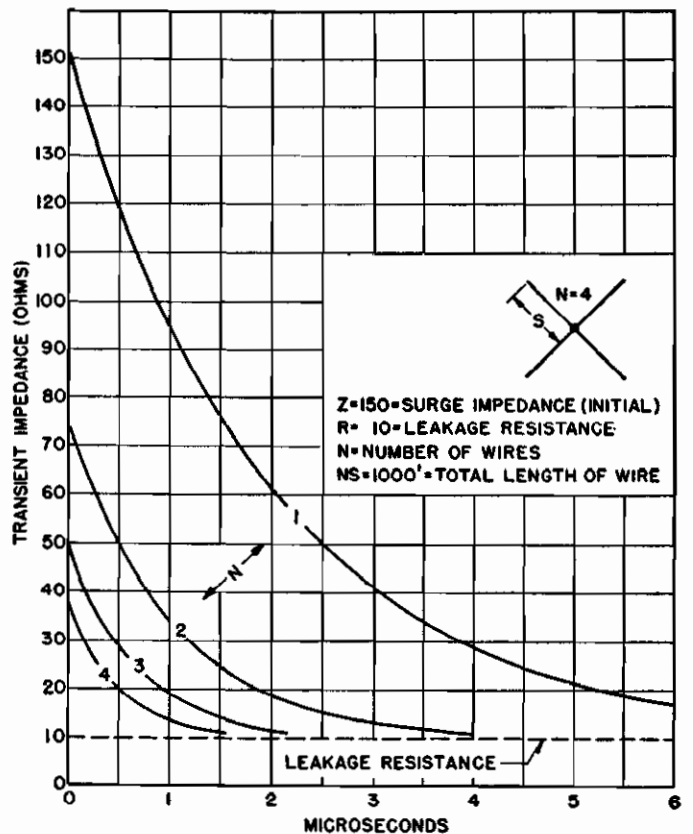

Fig. 18—Effect of number of wires on the counterpoise impedance.

is about 150 to 200 ohms. As the surge current travels along the counterpoise this initial surge impedance is reduced to the leakage resistance in a time depending upon the length of the counterpoise and the speed of propagation of the surge. In general, the surge travels at approximately one-third the speed of light so that a 1000-foot counterpoise has an initial surge impedance of approximately 150 ohms and at the end of six microseconds an effective resistance equal to the leakage resistance. Likewise, a 250-foot counterpoise has an initial surge impedance of 150 ohms but reduces to the leakage resistance in 1.5 microseconds. This indicates the desirability of using many short counterpoises instead of one long counterpoise as the leakage resistance is dependent largely upon surface area so that this is the same whether one 1000-foot counterpoise or four 250-foot counterpoises are used. On the other hand, the counterpoise of four 250-foot sections has an initial surge impedance of 37.5 ohms and reaches the final leakage resistance in 1.5 microseconds as compared to 150 ohms and 6 microseconds for the 1000-foot counterpoise. The one important point in applying this rule is to be sure that the leakage resistance of the counterpoise is lower than the initial surge impedance, otherwise positive reflections result and the tower footing is raised rather than lowered. The curves of Fig. 18²¹ illustrate the above discussion. Some of the

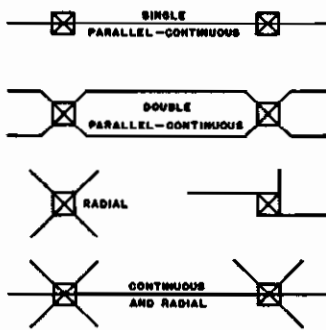

Fig. 19—Arrangements of counterpoises.

arrangements of counterpoises that have been used in actual tower construction are shown in Fig. 19.

The steps necessary to apply counterpoises properly are given in the E.E.I. report F6 by Merrill DeMerit.²⁰ This takes into account all surface factors. A close estimate can be obtained by driving say an eight-foot rod and from the proper resistance curves arrive at an average specific resistance for the soil. Reference to counterpoise curves for this specific resistance shows the leakage resistance of counterpoise of different lengths or reference to the resistance curves for driven rods gives the effectiveness of rods in reducing the ground resistance. Mr. DeMerit's curves indicate 10 ohms tower-footing resistance for a specific resistance of 1000 ohms and proportionately higher for higher earth resistances. Thus knowing the resistance of the elements of the circuit a prediction of the results can be made.

For example, assume by driving an eight-foot ground rod the specific resistance at a tower location is calculated to be 2500 ohms. The expected resistance of the tower is

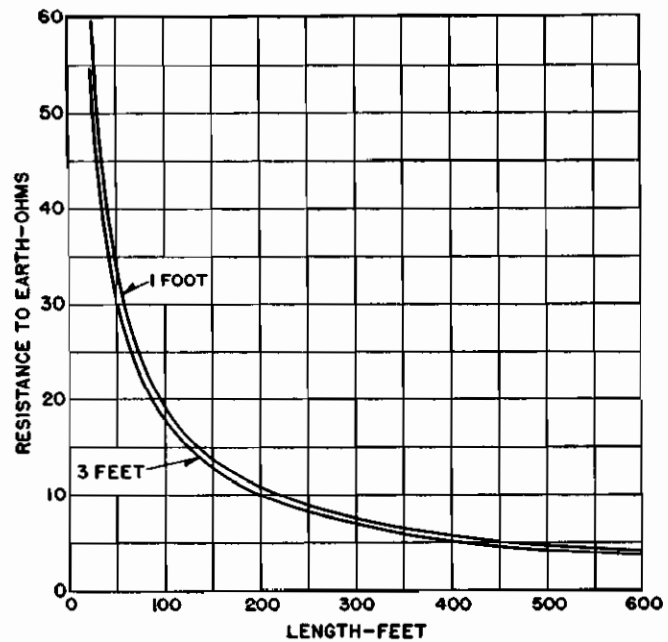

Fig. 20—Resistance to earth of $\frac{3}{8}$ -inch single counterpoise for two depths ($\rho = 1000$ foot ohms).

Calculated from H. B. Dwight paper "Calculation of Resistance to Ground."

$$R = \frac{\rho}{4\pi L} \left(\log_e \frac{4L}{a} + \log_e \frac{4L}{S} - 2 + \frac{S}{2L} - \frac{S^2}{16L^2} \right) \text{ where}$$

$2L$ = length in centimeters, S = distance wire to image in centimeters, and a = radius of wire in centimeters.

25 ohms. Driving four 32.0 foot long $\frac{3}{4}$ -inch diameter rods on the corners of a 30-foot square would give a resistance of 25 ohms (Figs. 16 and 17). The resultant resistance of this combination is 12.5 ohms. Or with 200 feet of wire buried 3 feet deep the resistance is also $12\frac{1}{2}$ ohms (Fig. 20). Omitting the time factor for going from the initial to the final or steady-state impedance of the counterpoise is not serious where the counterpoise is short

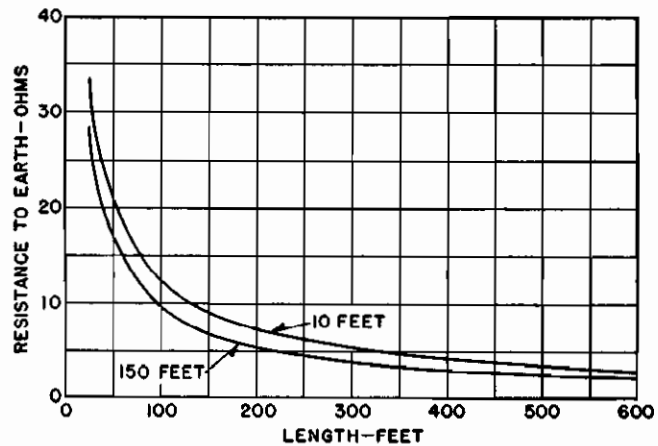

Fig. 21—Resistance to earth of two parallel $\frac{3}{8}$ -inch counterpoises plotted for two separations at a depth of 2 feet ($\rho = 1000$ foot ohms).

Calculated from H. B. Dwight "Calculation of Resistance to Ground."

as the average rate of rise of potential in the stroke is such that the effect of this time element is negligible.

The question arises as to the proper depth to bury the wire. As shown in Fig. 20 the depth does not materially affect the resistance of the counterpoise. It is necessary to bury only deep enough to prevent theft.

Where it is necessary to bury more than one counterpoise in each direction from a tower and when the width of right-of-way dictates parallel counterpoise there is the question of the proper distance between the wires. The curves of Fig. 21 indicate that the 150-foot spacing lowers the resistance a small amount below that of the 10-foot spacing. Therefore the spacing should be as large as possible. Usually it is possible to space the counterpoise wires at least as far apart as the two outside conductors. In general it is possible to space them 40 feet apart, which gives approximately the results of the 150-foot curve.

The fact that depth is not a great factor in securing low

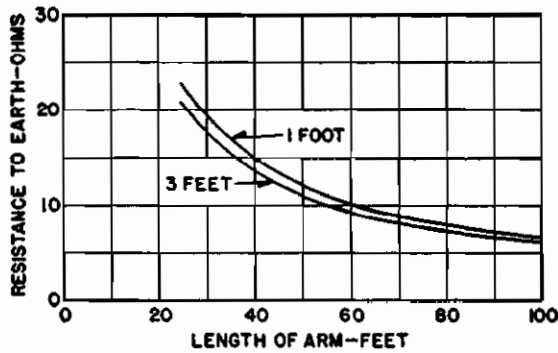

Fig. 22—Resistance to earth of $\frac{3}{8}$ -inch four-point star counterpoise plotted for two depths ($\rho = 1000$ foot ohms).

Calculated from H. B. Dwight "Calculation of Resistance to Ground."

$$R = \frac{\rho}{8\pi L} \left(\log_e \frac{2L}{a} + \log_e \frac{2L}{S} + 2.912 - 1.071 \frac{S}{L} + 0.645 \frac{S^2}{L^2} \right)$$

Where L = length of arm in centimeters.

S = distance wire to image in centimeters.

a = radius of wire in centimeters.

leakage resistance for the counterpoise is again illustrated in the curves of Fig. 22, calculated for a four-point star counterpoise.

12. Clearances

Air clearances must be large enough to have as great an impulse breakdown as that over the insulation itself. That is, in calculating the protection or probability of outage of a line it is essential to use the lowest figure of impulse-breakdown strength whether it be over the insulator string or whether it be from the conductor to ground point. An easy method of checking this for air clearances as compared to that of the standard insulator unit is shown in Fig. 5.

13. Arcing Rings

Arcing rings or arcing horns were once quite popular. It was reasoned that if properly designed the 60-cycle arc would be kept clear from the porcelain, and also there was

some belief that the impulse characteristics of the insulator string were improved. The use of high-speed clearing of faults and improved porcelain have practically eliminated the first reason. It is now found that any device that tends to prevent cascading of the arc over the insulator reduces the impulse strength of the insulator.

14. Size and Spacing of Insulators

The standard porcelain insulator is one having a shell 10 inches in diameter and a spacing of $5\frac{3}{4}$ inches from center to center. It is not difficult to increase this spacing between discs, and consideration has been given to changing the diameter of the porcelain. The impulse characteristics of three different diameters with three different spacings are presented in Fig. 23.²² They show, for instance, that 16 insulators, $4\frac{3}{4}$ -inch spacing have a somewhat lower impulse strength than 16 insulators with $6\frac{1}{2}$ -inch spacing. The cost of a power line is, however, determined more by the steel than by the number of insulators in the string. The 16, $6\frac{1}{2}$ -inch spaced units require more steel and greater spacings to maintain proper clearances than the shorter spaced units. Or, in other words, for a given length of insulator string fixed by tower construction the closer spaced units will give a higher overall impulse strength. Likewise, as the diameter of the insulator is increased the impulse strength is slightly increased. Increasing the diameter and shortening the spacing naturally increases the cost of a given string length. The correct selection therefore is a compromise between cost and performance. The 10-inch $5\frac{3}{4}$ -spaced units is a satisfactory compromise.

The flashover characteristic curves of Fig. 23 for standard insulators do not agree with the standard insulator curves of Fig. 5. The curves of Fig. 5 are the accepted curves for determining flashover characteristics of standard insulators since they are based on more recent laboratory tests made since the standardization of laboratory techniques. The curves of Fig. 23 should be used only for comparing the impulse flashover characteristics of insulators of various diameters and spacings.

15. Wood Construction

Many forms of wood construction are available. One consists of a steel tower, wood crossarms and suspension insulators. The wood insulation plus the insulators increases the overall impulse strength. The design factors are the same as above except the advantage of wood insulation can be utilized up to the point of the next weakest path, which is probably from the conductor to the steel tower with conductor swing. In order to arrive at the design constants it is necessary only to determine the weakest point in the design, convert this into equivalent insulators and apply the curves directly.

The data are equally applicable to all wood construction. For example assume a 115-kv H-frame line with the dimensions shown in Fig. 24. As in the case of the steel design the ground wires must be placed to form an angle of 30 degrees or less on the level. If the line is to be on a hillside the slope of the hill must be subtracted from the 30 degrees. The use of a second crossarm to support the ground wires as shown in Fig. 24 (a) may save in cost, as it allows the use of shorter poles in securing the protective

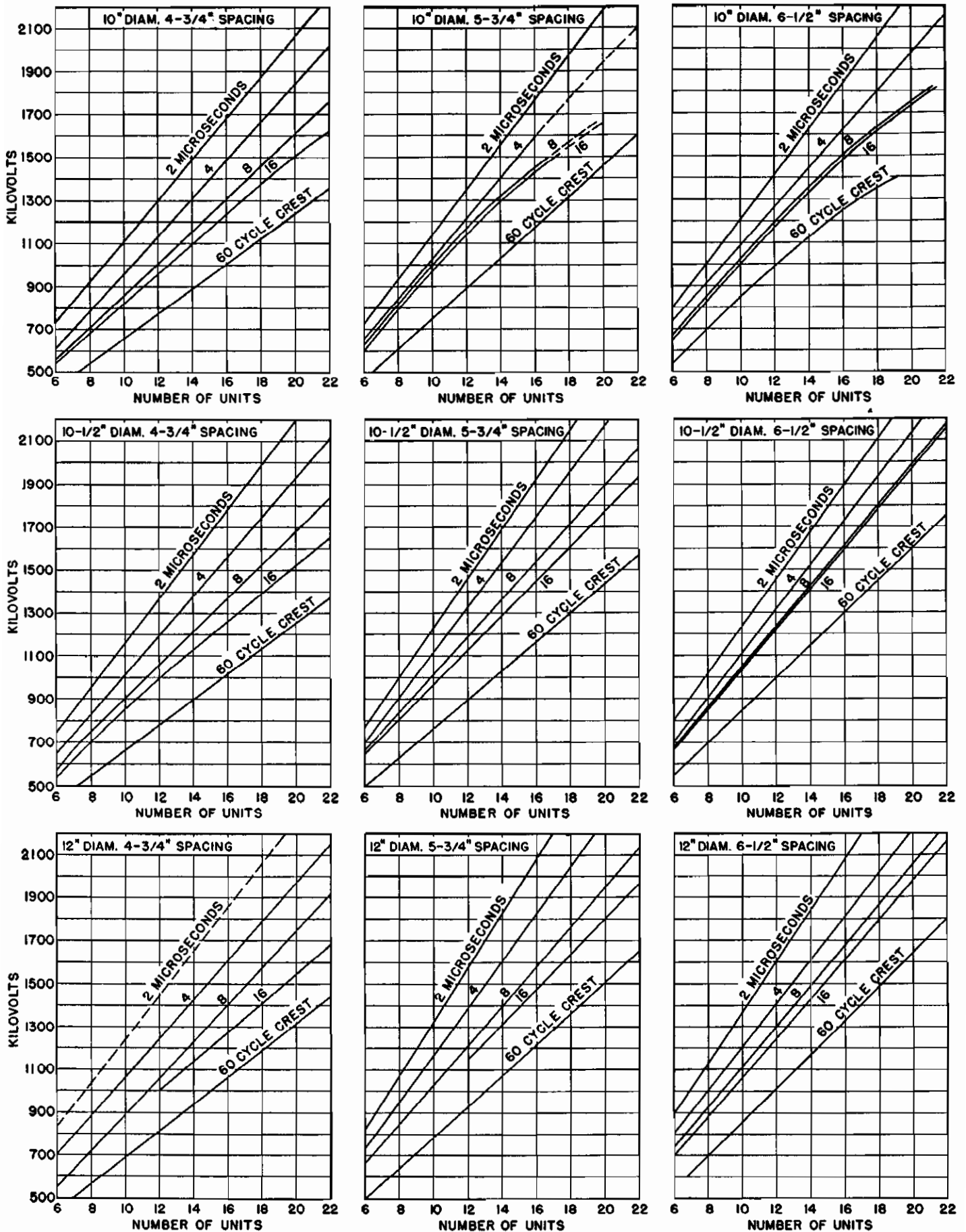

Fig. 23—Time-lag flashover characteristics of suspension insulators of various sizes and spacings. All values are based on $1\frac{1}{2} \times 40$ positive waves and humidity corrected to 6.5 grain.

angle. This will act also as a brace and may reduce the necessity for elaborate X-braces below the conductors. Many combinations are given in the article by Mr. Naney.²³ This fixes the height of ground wire. Seven insulators + 7 feet of wood is equivalent to 695 + 700 kv or a total of 1395 kv where a good average value of wood is taken as 100 kv per foot for the long times to flashover. For detailed and close designs reference should be made to the published data^{4,13,24}. The value B is 7 feet minus 2 feet or 5 feet in air, which has a minimum impulse level of 950 kv when the insulator string is at an angle of 30 degrees. The total impulse strength for 7 feet of air is 1310 kv for the insulator in the vertical position. The line strength is therefore 950 kv with high wind or 1310 kv with no wind and not the strength developed by the wood-arm plus the insulators shown above to be 1395 kv. The figures, 950 kv and 1310 kv, are the equivalent of 10 insulators or $14\frac{1}{2}$ insulators respectively. All the design features can now be determined. For example, assume the line is designed for the full swing of the insulator or an equivalent of ten insulators. The clearance from the conductor to ground wire must exceed five feet. Satisfying the protective angle assures this clearance. In the example discussed above the midspan clearance is 14 feet, under normal conditions. Referring to Figs. 4(c and i) and assuming that 10 ohm tower-footing resistance is possible,

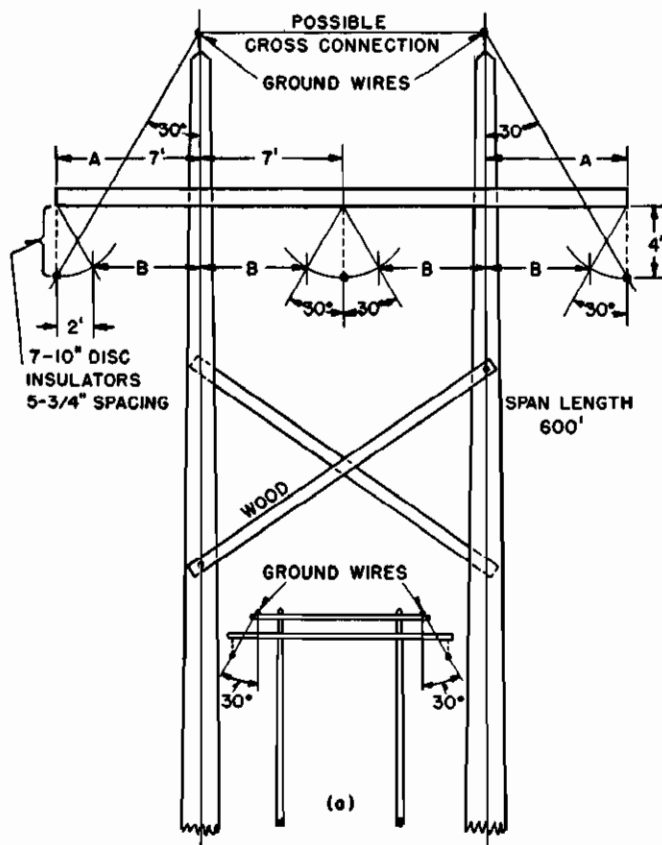

Fig. 24—Design of H-frame type of wood pole line based on direct stroke theory.

(a) Alternate plan using two crossarms permitting use of shorter poles to secure 30 degree angle.

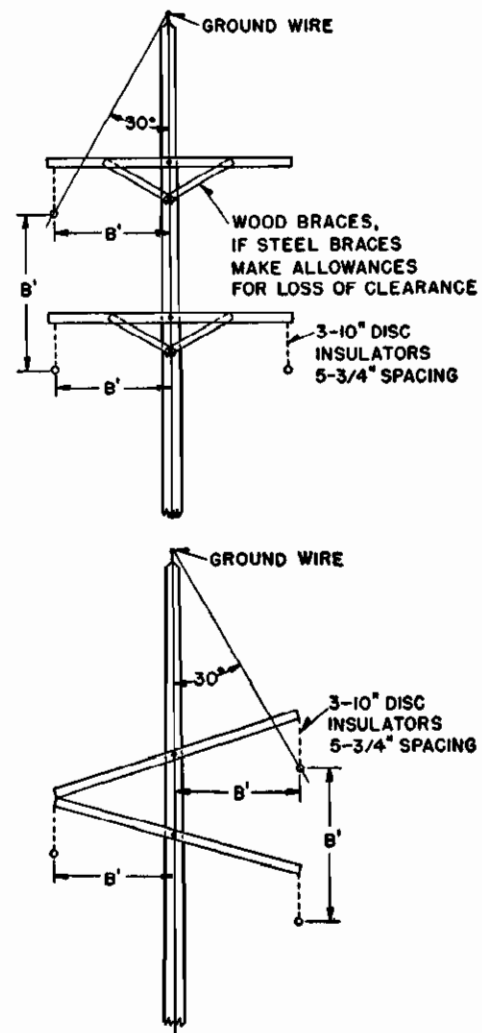

Fig. 25—Design of single pole structures based on direct stroke theory.

the line should be good for 110 000 and 100 000 amperes stroke current to tower and midspan, respectively with a probability of outage of 0.6 per 100 miles per year for a 30-storm level. If the construction of Fig. 24 (a) is used it might be necessary to use differential sagging, i.e., allow the ground wire to sag less than the phase wires to obtain adequate clearance at the midspan. Where sleet is a problem, this construction might not be permissible. In this manner a design of wood-pole line can be developed from the same curves. The procedure in arriving at dimensions for other wood-pole constructions is the same as outlined for the H-frame line.

In considering wood design the splitting of the wood is quite serious. The ground wire and down lead protect the pole but quite often the crossarms are shattered by the stroke. The double crossarm, one on either side of the pole, eliminates possible dropping of the line but does not remove the shattering problem. Well-seasoned wood apparently is not as susceptible to shattering as green wood. This is true for poles as well as crossarms.

The manner of grounding a wood-pole line depends on soil conditions and may range from a butt wrap on the

pole, to the driving of ground rods, or to some form of counterpoise as for a steel line. Wood poles must be guyed at corners or angle points. Care must be exercised in the location of these as on improperly designed lines an undue proportion of outages will be concentrated at these points. If it is not possible to locate the guy to give adequate clearance, then wood strain insulation in the guy should be considered with horns used around this wood to eliminate splintering.

The ground wire is effective for lines with operating voltages above 34.5 kv where low ground resistances are secured. The clearances commensurate with the construction for voltages lower than 34.5 kv are such that the use of ground wires are questionable. Here reclosing breakers, deion protector tubes and other forms of protection are more practical.

16. Other Forms of Construction

A short section of line was built with wood separating the steel structure from the ground wire. Here the grounding was accomplished by separate guy wires as in Fig. 26.

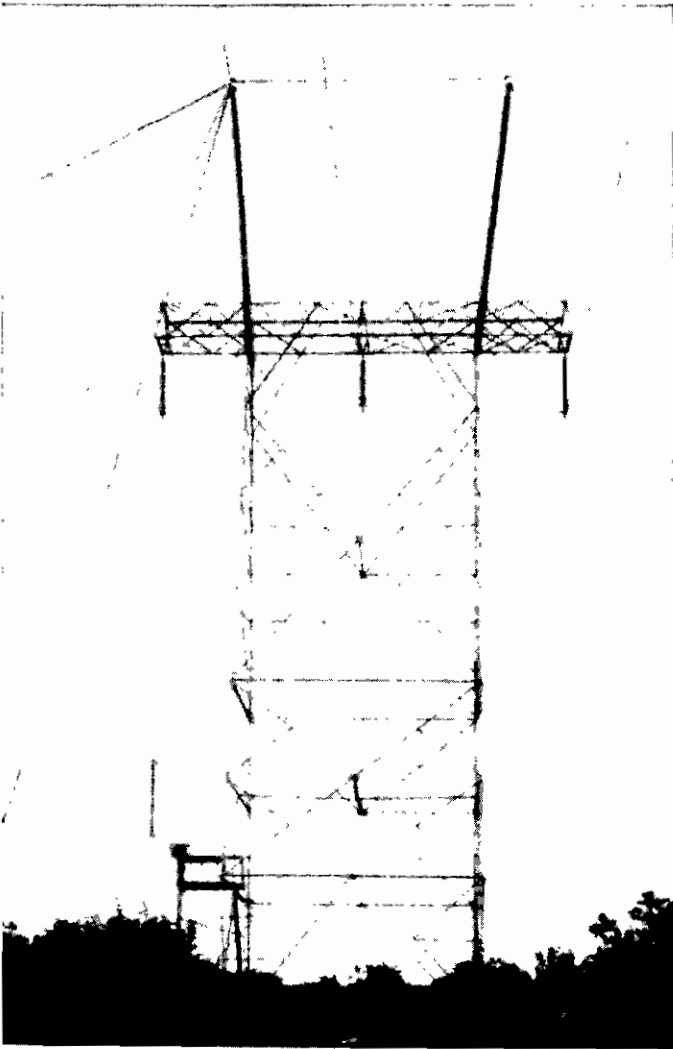

Fig. 26—Wallenpaupack-Siegfried 220-kv line with ground wires designing based on diverter principle.

In this type of construction, sometimes called the diverter scheme, because up to the point of insulation flashover no current flows through the tower, the only stress on the insulators is the induced potential up to the point of flashover of the wood pole. Although the construction is very effective it does not lend itself to economical line design.

Another scheme used in connection with substations and suggested for lines, is to erect separate steel masts tall enough to shield the phase wires from the stroke. This is practical only for shielding existing substations or very special line cases. It is effective where high ground resistance is encountered. Usually low ground resistance can be obtained, which allows the direct connection of the ground wires to the steel supporting structures. In this scheme no surge current passes through the tower and therefore there is no tendency to flash over an insulator string.

IV. PROTECTION BY AUXILIARY DEVICES

The second method of protection, making use of auxiliary devices or non-shielding has been extensively used in improving the performance of lines against lightning. Here the path of the discharge is controlled and some device used to extinguish the power follow arc.

Several devices have been used, such as lightning arresters, fuse arcing links, and protector tubes. The lightning arrester is too expensive for general application and

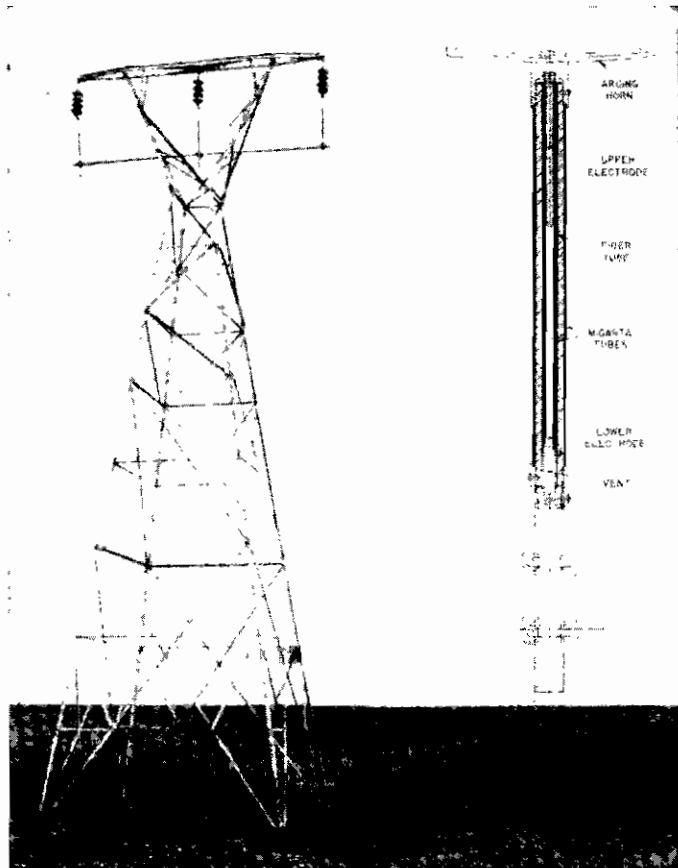

Fig. 27—Protector tubes on steel tower, 66-kv line of the Interstate Power Company and cross section of a typical tube.

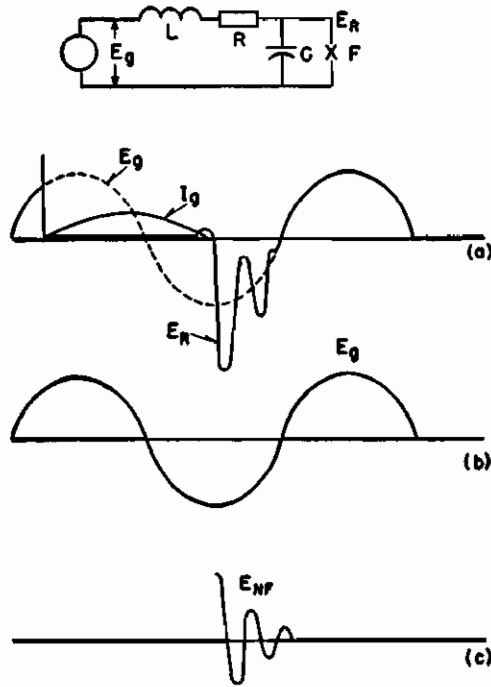

Fig. 28—Elements of recovery voltage.

E_g —generated voltage, I_g —generated current.
 E_R —protector tube voltage.
 E_{NF} —natural frequency voltage.

has not been extensively used. The maintenance of the fuses on the arcing rings made their application limited. The most popular device at present is the protector tube. This device is simple both in construction and in operation. Basically it consists of a fiber tube with an electrode in each end and is applied so that the impulse breakdown through it is lower than that of the insulation to be protected. On a transmission tower one tube is often mounted below each conductor so that the upper electrode is connected to an arc-shaped horn located the proper distance below the conductor, thus forming a series gap with the conductor. The lower electrode is solidly grounded. When a surge appears on the conductor, the series gap is spanned and an arc is formed in the tube between the electrodes. The heat of the arc vaporizes some of the fiber of the tube walls, the resulting neutral gas being expelled violently into the arc stream sufficiently deionizing it to prevent the arc restriking after the first zero point of the 60-cycle power current. Since the protector tube is the most practical auxiliary device available at present, to improve the performance of lines against lightning, this discussion is confined to it.

17. Theory of Tube Operation²⁵

Since the protector tubes are to prevent flashover of line insulation their discharge voltage must be lower than the flashover voltage of that insulation. They must also be capable of interrupting the generated follow current. Operation of protector tubes can be more readily understood by first considering the phenomena involved in current interruption. After the surge currents are discharged to ground, the normal frequency or generated current may

follow; so for satisfactory operation, the protector tube must recover its insulation strength after generated-current zero faster than the system voltage rises. This can best be explained by considering the recovery voltage on a simple circuit.

The circuit shown in Fig. 28 possesses the basic elements required to illustrate the transient recovery voltage, following interruption of fault current. This circuit contains lumped constants of L , R , and C in such proportion that it will have a natural frequency of oscillation. When a fault is placed at F and later removed at a normal-current zero, an oscillating voltage appears across the condenser. It is composed of the normal-frequency voltage and a voltage whose frequency corresponds to the circuit's natural frequency. The simplest method of developing the oscillating voltage is to consider the generated voltage and oscillating voltage separately. At the instant the fault is removed, the voltage across the fault must be zero. This condition of zero voltage is satisfied if it is assumed that there is a natural frequency voltage that appears instantly equal and opposite in magnitude to that of the generated voltage. The sum of these two voltages E_R is therefore the recovery voltage of the circuit. The time to crest of the oscillation is approximately proportional to \sqrt{LC} . Therefore if either L or C is increased, the time to the recovery voltage crest of the natural-frequency oscillation increases. This conception is important as the L of the source and C of the line differ for different line conditions. Theoretically, the natural-frequency voltage starts equal to the generated voltage at the instant the fault is removed assuming no losses, and oscillates about this voltage as an axis. However, losses produce damping and this natural-frequency component decays at a rate depending upon the losses in the circuit.

When a protector tube discharges lightning and power current follows through the tube, it must have the prop-

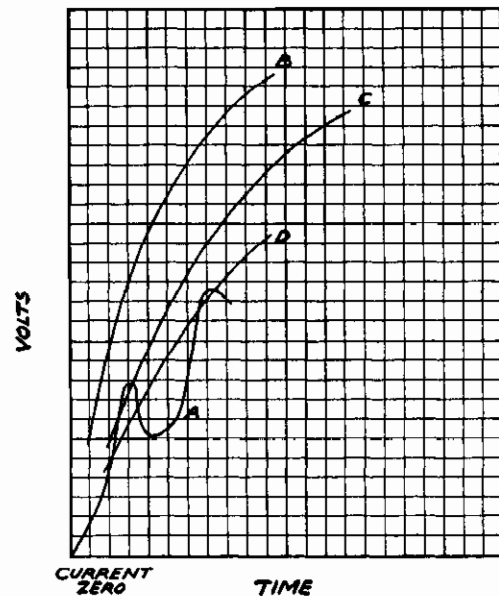

Fig. 29—Elements of protector tube operation.

A—recovery voltage of complex system.
 B, C, D—protector tube insulation recovery curves.

erties of changing from a good conductor to a good insulator for satisfactory operation. In any interrupting device it takes time to establish the insulating characteristics, which are commonly called the insulation recovery characteristics of the device. The interruption therefore starts a race between the insulation recovery strength of the device and the voltage recovery on the system. Curve A of Fig. 29 is the recovery voltage for a more complicated system. Instead of having simple oscillations as in Fig. 28 the recovery voltage is now a more complicated function of time as the result of a succession of traveling waves on the line.

Curves B, C, and D of Fig. 29 are hypothetical insulation-recovery curves for a protective device. If the protective device has the characteristics shown in Curve B and the system recovery characteristics are as shown in Curve A, then the interruption will be satisfactory, as the insulation recovery of the device is faster than the voltage recovery on the system. On the other hand, if the protective-device insulation recovery strength is as shown in Curve C or Curve D, then the system recovery voltage overtakes the insulation recovery strength at second or first crest, respectively, restriking will take place, and if this occurs at more than two consecutive current zeros, the operation is in general not considered satisfactory. It is therefore possible to predetermine the operation of tubes on a system by comparing the insulation recovery strength of the tube and the system recovery voltage.

The protector-tube insulation recovery curves and the voltage recovery curves will differ for each current. For a given short-circuit current the protector-tube insulation recovery curves also are lower with increased bore. Thus, if the protector tube, when new, starts with a characteristic such as shown in Curve B, Fig. 30, as it erodes the bore will increase and the curve will drop until at Curve C it will fail to give satisfactory interrupting characteristics.

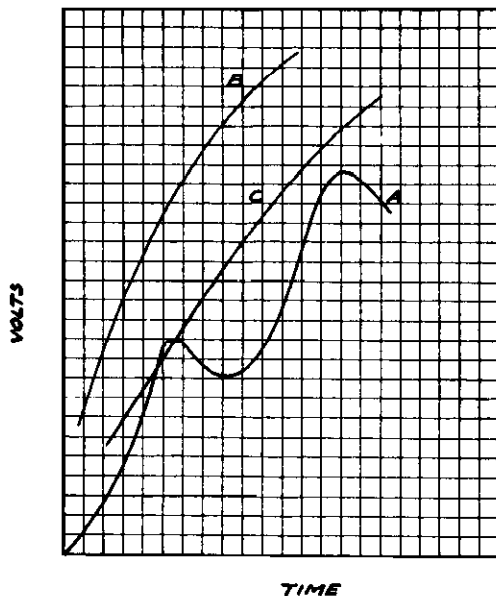

Fig. 30—Effect of erosion on protector tube operation.
 A—recovery voltage of complex system.
 B, C—protector tube insulation recovery.

For this reason the rate of erosion must be considered in protector-tube design. Likewise, the same tube will have different insulation recovery curves for different current magnitudes. Curve A, Fig. 31, may be insulation recovery

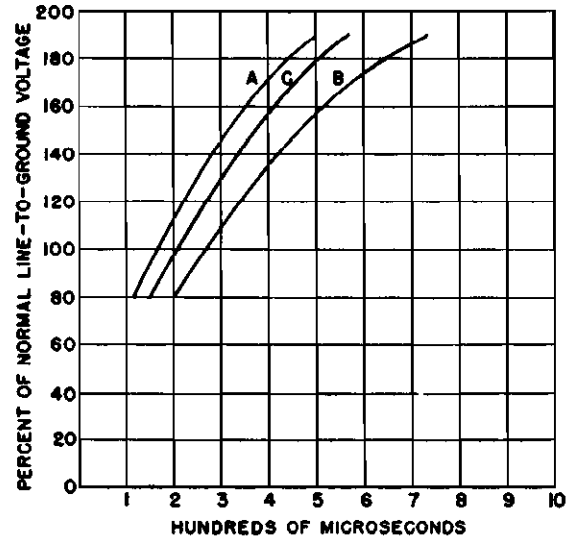

Fig. 31—Effect of current on recovery voltage of protector tube.
 A—characteristic curve for maximum current—1500 amperes.
 B—characteristic curve for minimum current—500 amperes.
 C—characteristic curve for 1000 amperes.

strength for maximum current, and the insulation recovery strength for minimum current might be of the order of Curve B, of this figure.

It is important that the system recovery voltage curves be compared with the insulation recovery strengths of the protective device to see that operation will be correct. The following discussion will therefore deal with system characteristics and protector-tube characteristics showing how this has been done to arrive at a standard line of protector tubes.

18. Protector-Tube Characteristics

The requirement that the breakdown voltage of a tube must be lower than that of the line insulation naturally limits the length of air between the inner electrodes as well as limits the length of gap external to the tube, as the sum of these two gaps determines the breakdown voltage of the device. The external series gap is provided for the purpose of withstanding normal impressed voltage to avoid possible corona or leakage currents across the protector tube itself under normal operating conditions. The impulse breakdown voltage level of protector tubes is best shown in the form of volt-time curves. The characteristics of a large number of different voltage ratings for the positive 1½×40 wave are given in Fig. 32. The volt-time characteristic of the protector tube is flatter than practically all forms of insulators. Thus it can be applied by simply comparing the critical voltage of the tube with the critical voltage of the insulators to be protected.

To simplify the application of protector tube, Table 8 not only shows the discharge level of protector tubes, but also includes the minimum string metal-to-metal arcing

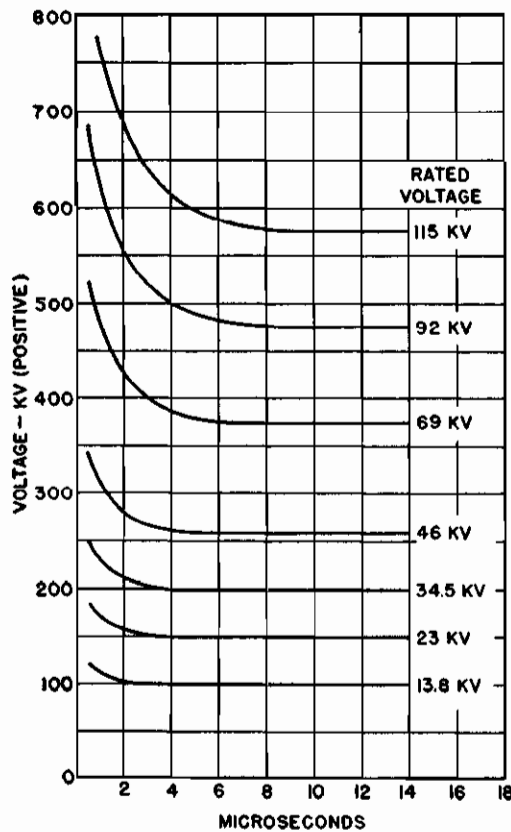

Fig. 32—Volt-time curves of De-ion protector tubes (Positive $1\frac{1}{2} \times 40$ microsecond wave).

distance that the tube is expected to protect. These figures include a factor of ten percent between the actual discharge voltage of the protector tube and the impulse flashover voltage corresponding to the dry arcing distance. Sufficient clearance should be provided between the protector tube and the structure to which it is attached to be sure

TABLE 8

Circuit Voltage Rating	Tube Discharge ⁽¹⁾ Critical Voltage Representative Value Dry $1\frac{1}{2} \times 40$ Wave		Protector Tube Impulse Discharge Voltage Characteristics		
	Pos.	Neg.	Series ⁽²⁾ Gap Inches	Min. Dry Arc Distance Tube Will Protect	Number Standard Ins. Discs Tube Will Protect $5\frac{3}{4} \times 10$ " Spacing
13.8	100	110	$\frac{3}{4}$	6"	1
23	150	155	$1\frac{1}{2}$	9"	2
34.5	200	220	2	$12\frac{1}{2}$ "	2
46	260	285	$3\frac{1}{4}$	17"	3
69	375	420	$5\frac{1}{2}$	28"	5
92	475	540	$8\frac{1}{2}$	6
115	575	635	11	7

⁽¹⁾Actual Values will vary somewhat, depending on the design and mounting of the tube.

⁽²⁾These are recommended minimum series gaps. Under no conditions of operation should the series gap be less than 80% of the recommended minimum.

that lightning flashover will be confined within the protector tube itself.

The ability of a protector tube to operate properly is a function of the insulation recovery characteristics of the protector tube for a fixed short-circuit current. This insulation recovery characteristic varies with the magnitude of short-circuit current through the protector tube. These properties are illustrated in Fig. 31. Likewise, the insulation recovery for a given current is dependent upon the bore. As the bore of the tube increases in diameter the clearing characteristics of the tube undergo a change, the effect being to lower the insulation recovery characteristics of the tube with increased diameter. Likewise, the operation of the protector tube volatilizes fiber from the tube wall with the result that the bore increases with each operation. This characteristic necessitates the selection of a bore such that after a given number of operations the insulation recovery strength of the tube is still high enough to permit satisfactory performance. These characteristics are illustrated in Fig. 33.

Actual measurements of the bores of protector tubes after years of service show plainly that erosion of the bore by repeated operation does not seriously affect tube life. On one line of one thousand tubes with ratings of 600 to 2000 amperes none were found²⁶ after five years of service to have reached the end of their useful life. A similar study²⁷ on tubes rated at 1000 to 4000 amperes on a 132-kv system showed a total of 63 operations in four years but measurements of the erosion of the tubes indicated that the bore was still within the manufacturing tolerance used at the time of assembly of the device. The rate of erosion might be considerably increased if used for the protection of disconnecting switches or the like where the tube provides the only path for a long length of line.

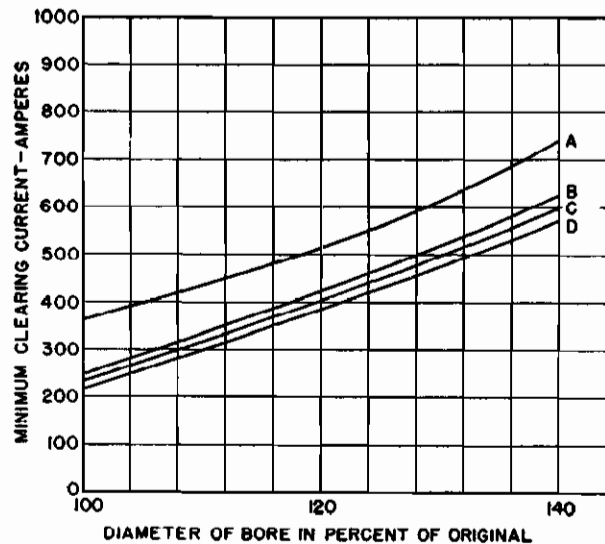

Fig. 33—Effect of erosion on minimum current required for interruption.

Time to recovery voltage crest 100 percent normal line to neutral

A—200 microseconds.

B—500 microseconds.

C—1000 microseconds.

D—2000 microseconds.

In general, the protector tube can withstand lightning stroke currents of 50 000 to 100 000 amperes on the basis of a current wave that rises to crest in 10 microseconds and decays to half value in 20 microseconds. Experience to date with a large number of tubes shows that the probability of failure from lightning is small, allowing the conclusion that the impulse discharge capabilities of protector tubes are sufficient to withstand all but the most severe direct strokes.

Experience with modern finishes indicates that the tube has good weathering characteristics. The exact performance will depend on local atmospheric conditions. Periodically applying a good paint to the protector tubes increases their weather resistance as well as improves the electrical characteristics of the exterior.

The operation of the protector tube results in the expelling of ionized gases that must be properly directed to avoid flashover from live conductors to ground. Experience with the application of a large number of protector tubes indicate that this is not a serious requirement, and can readily be satisfied with the available mechanical settings, and arrangements of tubes. When arranging the mounting of the protector tube, care must be taken to direct the discharged ionized gases so as to avoid flashover to another phase or to ground. The length of visible flame path as a function of the power current and voltage is shown in Fig. 34. Obviously, the circuit voltage and the

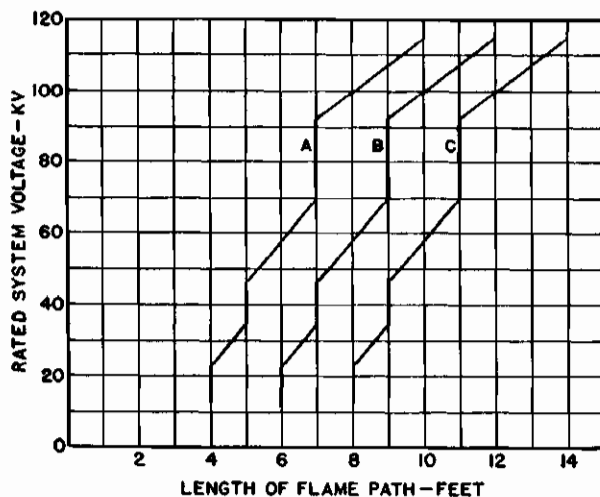

Fig. 34—Visible flame path as a function of power current and voltage.

- A—1500 amperes.
- B—2000 amperes.
- C—5000–6000 amperes.

protector-tube dimensions should be considered when establishing the safe strike distance from the gas envelope to the object of different potential. Recoil forces must be considered when designing the mounting hardware. It is of importance that the mounting hardware be designed to facilitate ease of installation.

The normal rating of the protector tube is based on a solidly grounded neutral system and any deviation from this should be taken into account in the application of the

device. Likewise, since current is an important factor in the correct operation of this device, the maximum and minimum current must be calculated for the range of system operating conditions. Such calculations should be made for the single, double, and three line-to-ground fault currents and naturally the corresponding recovery voltages must be evaluated. A number of factors will determine the magnitude of the currents and the associated recovery voltages. For example, the method of grounding the neutrals (solid grounding, resistance or reactance grounding, or any combination of these), maximum and minimum connected capacity (variation in operating conditions), length of connected circuit or lines in miles, relative location of short-circuit current sources, line configuration and presence of overhead ground wires, tower-footing resistance, and protector-tube location. The method of making short-circuit calculations will be found in reference 28. The method of determining recovery-voltage characteristics of systems has also been defined in the printed matter^{29,30,31}. For this reason these methods will not be reviewed at this time.

19. Selection of Tube Rating

In order to facilitate the selection of tubes, Table 9 has been prepared. This table shows that if all factors are checked for a given application, the selection of the proper protector tube is not complicated. The table is prepared on the basis of a solidly-grounded neutral system which has all sources of short-circuit current solidly grounded. This is representative of the type of system found particularly at the higher operating voltages. The effect of tower-footing resistance is to reduce the current and to reduce the magnitude of recovery voltages across the tube. This resistance reduces the recovery voltage because of the improvement of the power-factor in the circuit, which means that at current zero or time of interruption, the instantaneous fundamental frequency voltage is of lower magnitude than for a pure reactive circuit. However, there is a lower limit to which the current can be reduced and still have successful operation.

For practical purposes the effect of system neutral resistance is similar to the effect of tower-footing resistance discussed above. In cases where both neutral grounding resistance and tower footing resistance are encountered, they should be considered as being in series. Thus the same limits apply as pointed out for solidly grounded systems with tower-footing resistance alone. If the sum of those resistances is such that a single protector tube does not have the current range to interrupt both the phase currents not limited by resistance and the single line-to-ground currents limited by resistance, then the use of four protector tubes can be considered where three protector tubes of a high current rating are connected in star, and the star point connected to ground through a protector tube of lower current rating.

When the system neutral (or neutrals) is grounded through reactance, standard protector tubes for solidly grounded service can be applied under conditions such that the zero-sequence reactance X_0 viewed from the protector tube locations is not more than three times as great as the positive-sequence reactance X_1 . When the

TABLE 9—RECOVERY VOLTAGE CHARACTERISTICS FOR WHICH TUBES ARE DESIGNED

System Kv.	Min. Miles of Line (1,2)	Tube Current Rating ⁽³⁾		Minimum Current		Maximum Current			
				Max. Significant Crest		1st Crest		Max. Significant Crest	
		Min. (4)	Max.	Per-cent Volt-age	Time Micro-sec.	Per-cent Volt-age	Time	Per-cent Volt-age	Time
13.8	10	300	1500	160	230	90	55	165	130
		400	3000	160	230	90	35	160	120
		600	6000	160	200	90	25	160	120
23	15	300	1500	165	400	73	65	165	250
		400	3000	165	400	86	45	160	190
		600	6000	165	400	94	30	158	190
34.5	22.5	300	1500	170	600	65	80	165	390
		400	3000	170	600	85	60	159	270
		600	6000	170	600	100	50	156	270
46	30	300	1500	165	800	70	115	165	530
		400	3000	165	800	90	80	159	370
		900	6000	165	750	105	70	153	330
69	45	400	1500	165	1100	85	180	165	800
		600	3000	165	1100	105	140	158	590
		900	5000	165	900	115	100	149	490
92	60	400	1500	160	1300	88	240	165	1070
		600	3000	160	1300	104	220	157	930
		1000	5000	160	1100	115	180	145	760
115	75	500	1500	160	1450	90	300	165	1350
		600	3000	160	1450	98	300	156	1270
		1000	5000	160	1350	105	300	140	1100
138	90	500	1500	160	1600	90	350	165	1440
		600	3000	160	1600	90	350	155	1320
		1000	5000	160	1500	90	300	136	1250

(1) Miles listed are the minimum circuit miles of overhead line connected or equivalent where the line has a single source of short circuit current at one end. Cable should be reduced to the equivalent miles of overhead line as indicated in Fig. 35.

(2) When two sources of short circuit current are available, the miles of line in Column 2 should be increased by a factor K, determined from Fig. 36. If less miles of line between sources are available than required by the use of Fig. 36 but more than shown in Column 2, then a detailed calculation is necessary for the application.

(3) Guide for application when minimum current is limited by resistance.

The minimum current rating which is assigned to standard protector tubes is based on the short circuit current through the tube being limited predominantly by inductive reactance. The protector tubes will actually interrupt currents as low as 85 per cent of their minimum nameplate rating for circuits 69 kv and above or 70 per cent of their minimum current rating for circuits 46 kv and below, where circuit resistance (tube grounding resistance) is included, provided the calculated minimum current neglecting all resistance is equal to or greater than the tube's minimum nameplate rating.

(4) Standard Tubes Operating at Reduced Voltage.

Where the minimum line-to-ground current of the circuit is below the minimum current rating assigned to standard tubes, and the insulation of the circuit is high enough to permit the use of a tube

ratio of X_0 to X_1 is greater than this, special consideration must be given to the protector tube. However, in many cases the protector tube for the next higher voltage rating will be applicable. When the protector tubes are used on a system using a tuned reactance or using a ground-fault neutralizer, the line-to-ground currents should not have to be cleared by the tube. Thus protector tubes built for line-to-ground voltage can be applied on the basis of the line-to-line fault currents only.

Protector tubes applied on an isolated-neutral system must be given special consideration, as the single line-to-ground current (charging current) will usually be below the minimum current rating for the suggested standard tube. In connection with the application of protector tubes to isolated-neutral systems consideration should be given to the four-tube scheme as such a scheme should ease the problem of interrupting charging current.

To facilitate the selection from a recovery-voltage viewpoint the reactance of the various ratings, in combination with a given length of line was set down. Column 2, Table 9, gives the lower limit of line that should be considered without making a detailed calculation. Actually however the recovery-voltage characteristics given in the last six columns should be taken as the limits for the standard protector tube and the recovery voltage for a given application should be less severe than herewith listed. The four

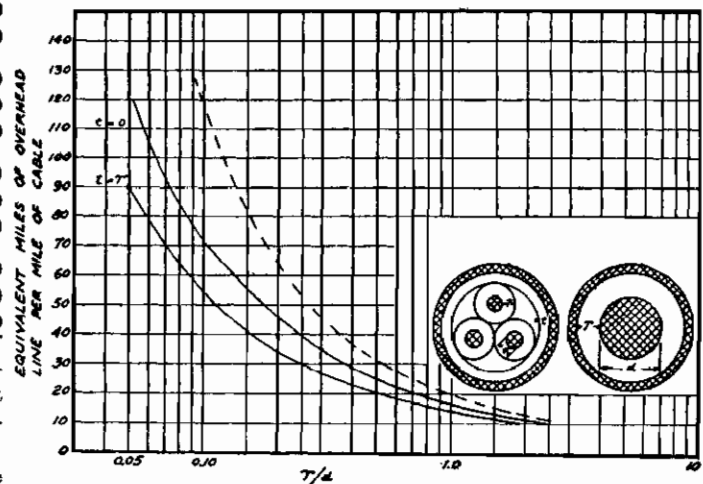

Fig. 35—Overhead line equivalent of cable.

--- Single conductor
— Three conductor

For paper insulated cable assumed dielectric constant 3.8 (For varnished cambric or rubber insulation multiply by 1.35). Overhead line equivalent based on positive sequence capacity, susceptance of 6.0 micromhos per mile.

having the next higher voltage rating, this higher voltage protector tube will interrupt lower than the listed minimum current.

To determine the minimum current which the protector tube will interrupt when used on a circuit below its voltage rating, multiply the normal minimum current rating of the protector tube by the ratio of the lower operating voltage on which the device is to be used to the normal voltage rating of the protector tube. This lower value of current can be considered as being limited by reactance only and applied in the same way standard tubes are applied.

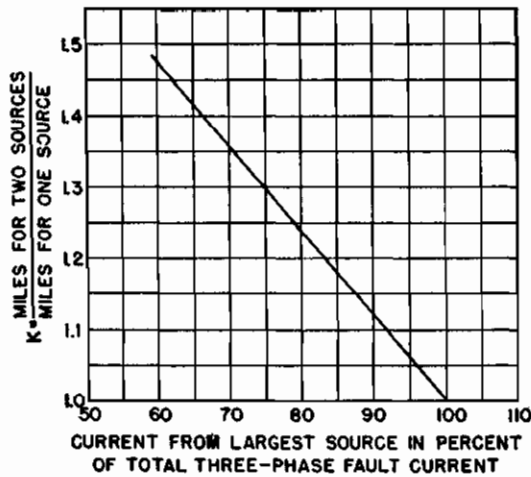

Fig. 36—"K" factor for line with two sources.

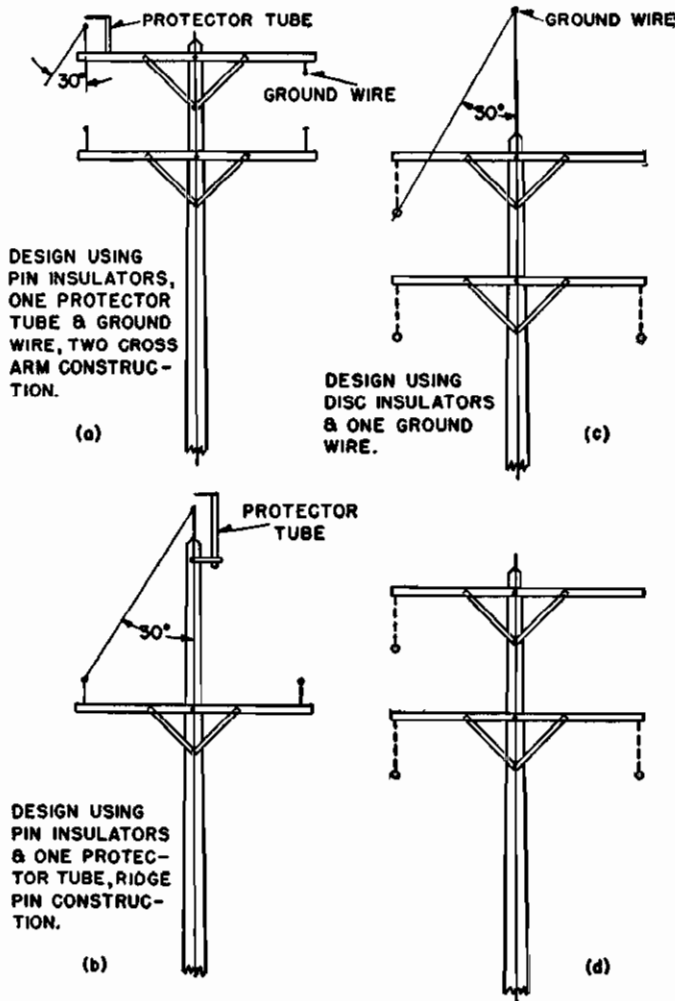

Fig. 37—Protection methods for some typical lines.

notes on the bottom of Table 9 give some rules for applications for other than standard condition.

20. Correct Operation

Protector tubes are designed to withstand one operation for tubes rated at 5000 and 6000 amperes, two operations

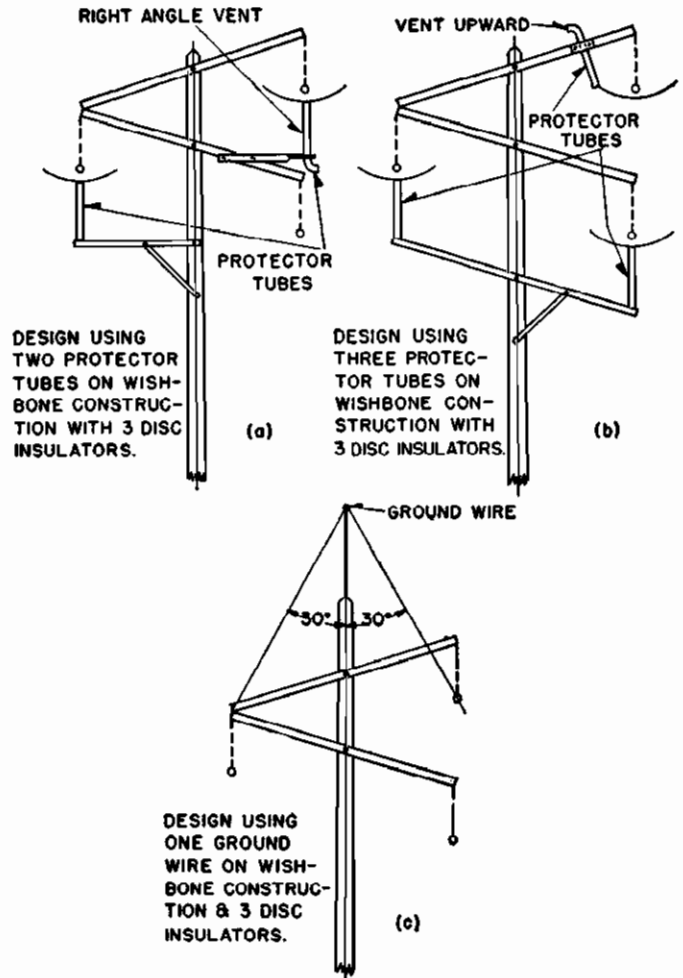

Fig. 38—Types of protection for wishbone constructed lines.

for tubes rated at 3000 amperes, and three operations for tubes rated at 1500 amperes, at maximum rated current with fully offset current wave after which the protector tube will be required to clear two operations at minimum rated current and with the associated recovery voltage. The tube performance is based on interruption of the current actually obtained during the one test at maximum rated current in less than 1/60 second and the minimum rated current in less than 1/40 second.

The maximum symmetrical nameplate rating in Table 9 is based on the maximum crest current that the tube will stand divided by a factor of not less than 2.5 to take into account the effect of asymmetry. The minimum symmetrical rms current rating is based on the minimum crest current divided by 1.41 to convert to rms amperes.

Service experience shows that systems using protector tubes should not have relay settings less than two cycles. Where relays have a shorter operating time, it will be necessary to introduce a delay to prevent unnecessary circuit outages. The best possible protection is secured when all insulation structures on the line are protected. When some are not protected, the degree of lightning protection will be decreased, the degree of protection depending on span length, insulation strength, ground resistance and tube breakdown.

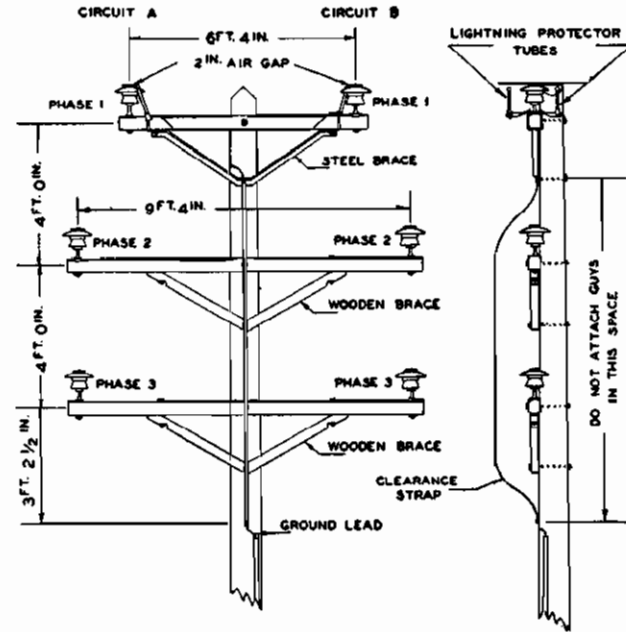
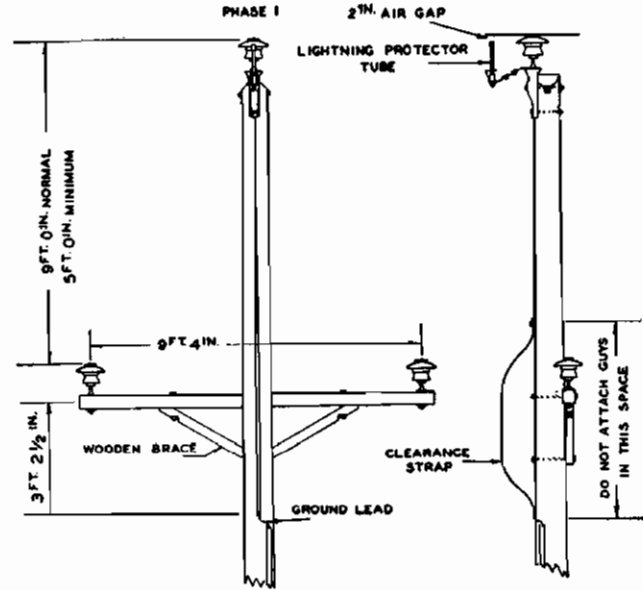
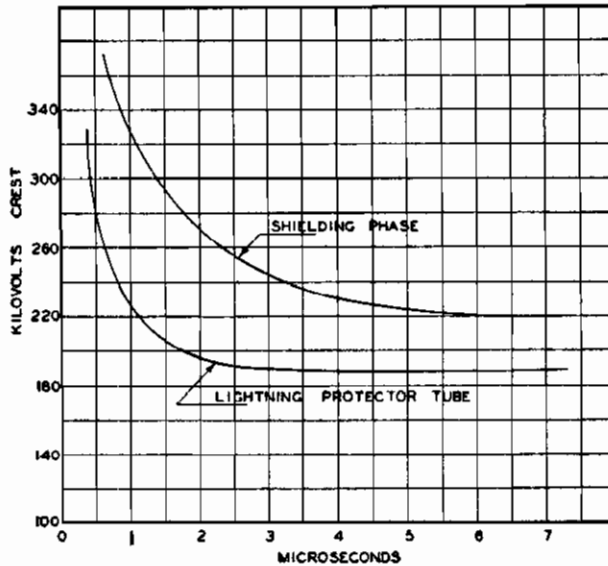
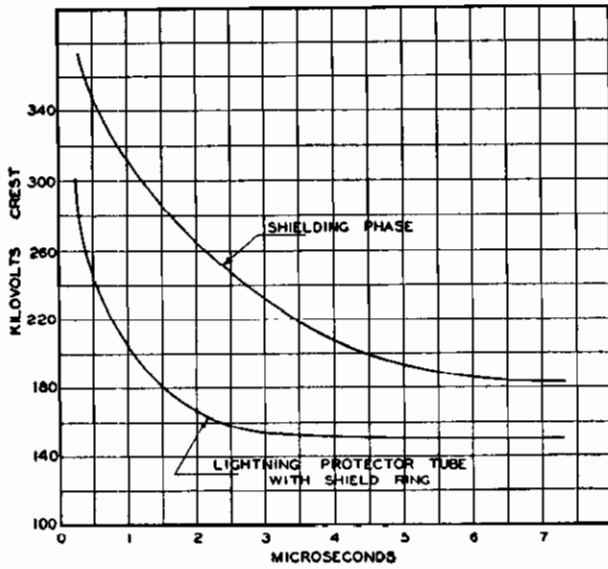

Fig. 39—Design of single- and double-circuit pole tops.

In applying tubes it is necessary simply to observe the limits as far as 60-cycle currents are concerned and see that the breakdown of the tube is lower than the insulator to be protected. Clearances, of course, should be adequate to assume that the surge will flow through the tube rather than over the insulator structure. A large number of arrangements have been used.

21. The Conductor—A Ground Wire

On many miles of line now in operation improved performance would be desirable. The construction of Fig. 37 (d) has been used extensively and the outages will be high. In some cases a ground wire is used on the spare space on the upper crossarm, Fig. 37 (a), but even with low ground resistance there is an even chance that lightning will strike

the upper conductor instead of the ground wire. The simplest method of correcting this difficulty, if a ground wire is present, is to install a protector tube on the insulator on the upper crossarm, Fig. 37 (a). The lower arm is now shielded and fair performance will be obtained depending on the length of crossarm and value of ground resistance.

If no ground wire is present the cheapest and most effective method of reconstruction would be to remove the upper crossarm, install an insulator on the top of the pole with a protector tube as shown in Fig. 37 (b). Again, an extension to the pole can be considered as in Fig. 37 (c) but usually this is difficult and expensive. Suggestions for reconstructing a line built of the wishbone type of construction are given in Fig. 38.

In building a new low-voltage line where low ground re-

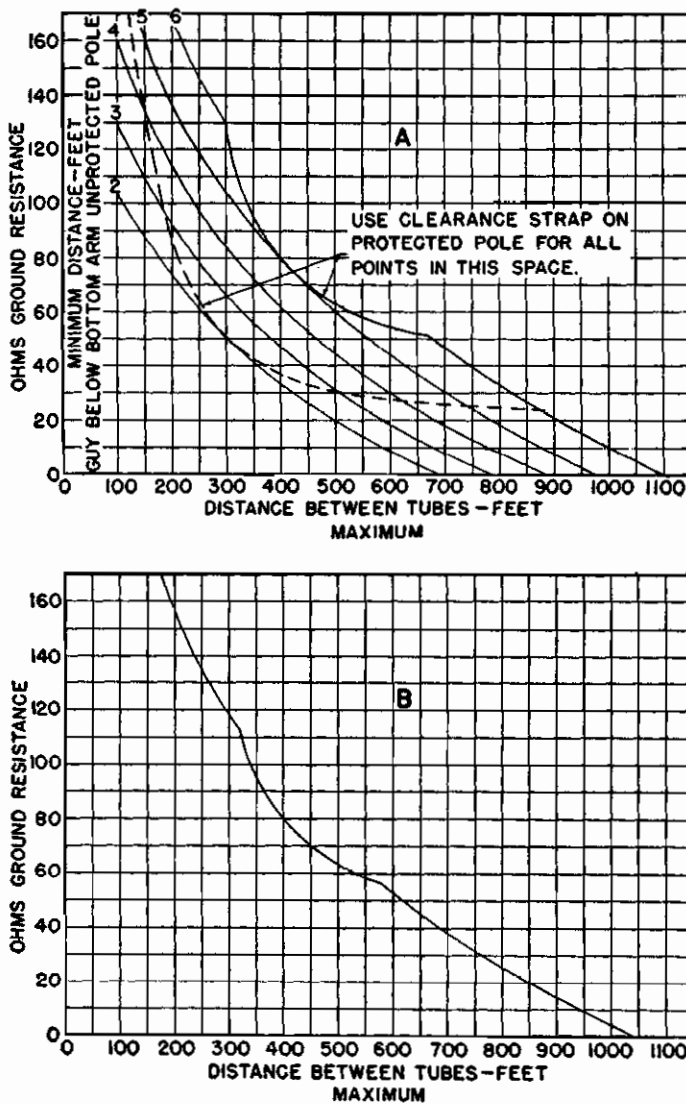

Fig. 40—Curves showing required location of protector tubes.
 A—single-circuit pole line. B—double-circuit pole line.

sistances are expected the construction of Fig. 37 (b) will no doubt be the most economical. If high resistances are present it will be necessary to use three tubes per pole. The spacing of the tubes will be dependent on span length and ground resistance. A large amount of line has been built in accordance with the construction of Fig. 37 (b). The details of construction and the factors used by Public Service of New Jersey were covered in a paper "Lightning Protection of Wood Pole Lines 40-22" by Sels and Gothberg presented at the A.I.E.E. Midwinter Convention, 1940. Figs. 39 and 40 show the data presented and are given here as they represent practice with which there has been experience. Although the curves are applicable for the 26-kv circuits they can be used to approximate the design proportions for lines up to 66-kv as the only difference would be in the pin-type insulation used. As the curves show, the lower the ground resistance, the more effective the scheme. The curves in Fig. 4 can also be used for estimating the possible performance on the basis that the

upper wire is a ground wire. Fig. 41 illustrates a number of methods of mounting protector tubes.

REFERENCES

1. Theoretical and Field Investigations of Lightning, by C. L. Fortescue, A. L. Atherton, and J. H. Cox, *A.I.E.E. Transactions*, V. 48, April 1929, pp. 449-468. (Also *A.I.E.E. Lightning Reference Book*, pp. 395-414.)
2. Direct Strokes—Not Induced Surges—Chief Cause of High-Voltage Line Flashover, by C. L. Fortescue, *The Electric Journal*, V. 27, August 1930, pp. 459-462. (Also *A.I.E.E. Lightning Reference Book*, pp. 546-549.)
3. Lightning Discharges and Line Protective Measures, by C. L. Fortescue and R. N. Conwell, *A.I.E.E. Transactions*, V. 50, September 1931, pp. 1090-1100. (Also *A.I.E.E. Lightning Reference Book*, pp. 801-811.)
4. *Mechanical Characteristics of Transmission Lines*, by L. E. Imlay (a book). East Pittsburgh: Westinghouse Technical Night School Press (1928).
5. Ice-Coated Electrical Conductors, by A. E. Davison. Paper presented at the Conference Internationale des Grands Reseaux Electriques a Haute Tension at Paris, France, on July 1, 1939.
6. Shielding of Transmission Lines, by C. F. Wagner, G. D. McCann, and G. L. MacLane, Jr., *A.I.E.E. Transactions*, V. 60, 1941, pp. 313-328.
7. Transmission and Protective Equipment, by J. J. Torok, W. R. Ellis, A. C. Monteith, and Edward Beck, *The Electric Journal*, V. 30, June 1933, pp. 253-257, July 1933, pp. 290-293, August 1933, pp. 347-352, September 1933, pp. 381-387, November 1933, pp. 467-71, December 1933, pp. 515-517, V. 31, February 1934, pp. 72-75, April 1933, pp. 151-155.
8. Transmission Line Design and Performance Based on Direct Lightning Strokes, E. L. Harder, J. M. Clayton, *A.I.E.E. Technical Paper* 49-111, 1949.
9. Experience with Preventive Lightning Protection on Transmission Lines, S. K. Waldorf (Discussion C. F. Wagner, G. D. McCann). *A.I.E.E. Transactions*, V. 60, 1941, page 702.
10. A Large-Scale General-Purpose Electric Analog Computer, E. L. Harder, G. D. McCann. *A.I.E.E. Transactions*, V. 67, 1948, pages 664-73.
11. Hydrometeorological Report No. 5—Part II, Hydrometeorological Section Office of Hydrologic Director, U. S. Weather Bureau, Aug. 1945. (for storms in U.S.)
12. The Distribution of Thunderstorms in the United States 1904-33, W. H. Alexander, *Monthly Weather Review*, V. 63, 1935, page 157. (for storms in Canada)
13. What Wood May Add to Primary Insulation for Withstanding Lightning, J. T. Lusignan, Jr., C. J. Miller, Jr., *A.I.E.E. Transactions*, V. 59, September 1940, pp. 534-40.
14. Lightning Performance of 110- to 165-Kv Transmission Lines by Philip Sporn (Committee Report), *A.I.E.E. Transactions*, V. 58, June 1939, pp. 294-304.
15. The Effect of Corona on Coupling Factors Between Ground Wires and Phase Conductors, G. D. McCann. *A.I.E.E. Transactions*, V. 62, 1943, pages 818-26.
16. Lightning Surge Effects on Transmission Lines, G. D. McCann. *Electric Light and Power*, (Chicago, Ill.) May 1945, pages 76-84.
17. Minimum Insulation Level for Lightning Protection of Medium-Voltage Lines, H. N. Ekvall, *A.I.E.E. Transactions* V. 60, 1941, pages 128-32.
18. Impulse and 60-Cycle Characteristics of Driven Grounds, P. L. Bellaschi. *A.I.E.E. Transactions*, V. 60, 1941, pages 123-28.
19. Impulse and 60-Cycle Characteristics of Driven Grounds-II, P. L. Bellaschi, R. E. Armington, A. E. Snowden. *A.I.E.E. Transactions*, V. 61, 1942, pages 349-63.

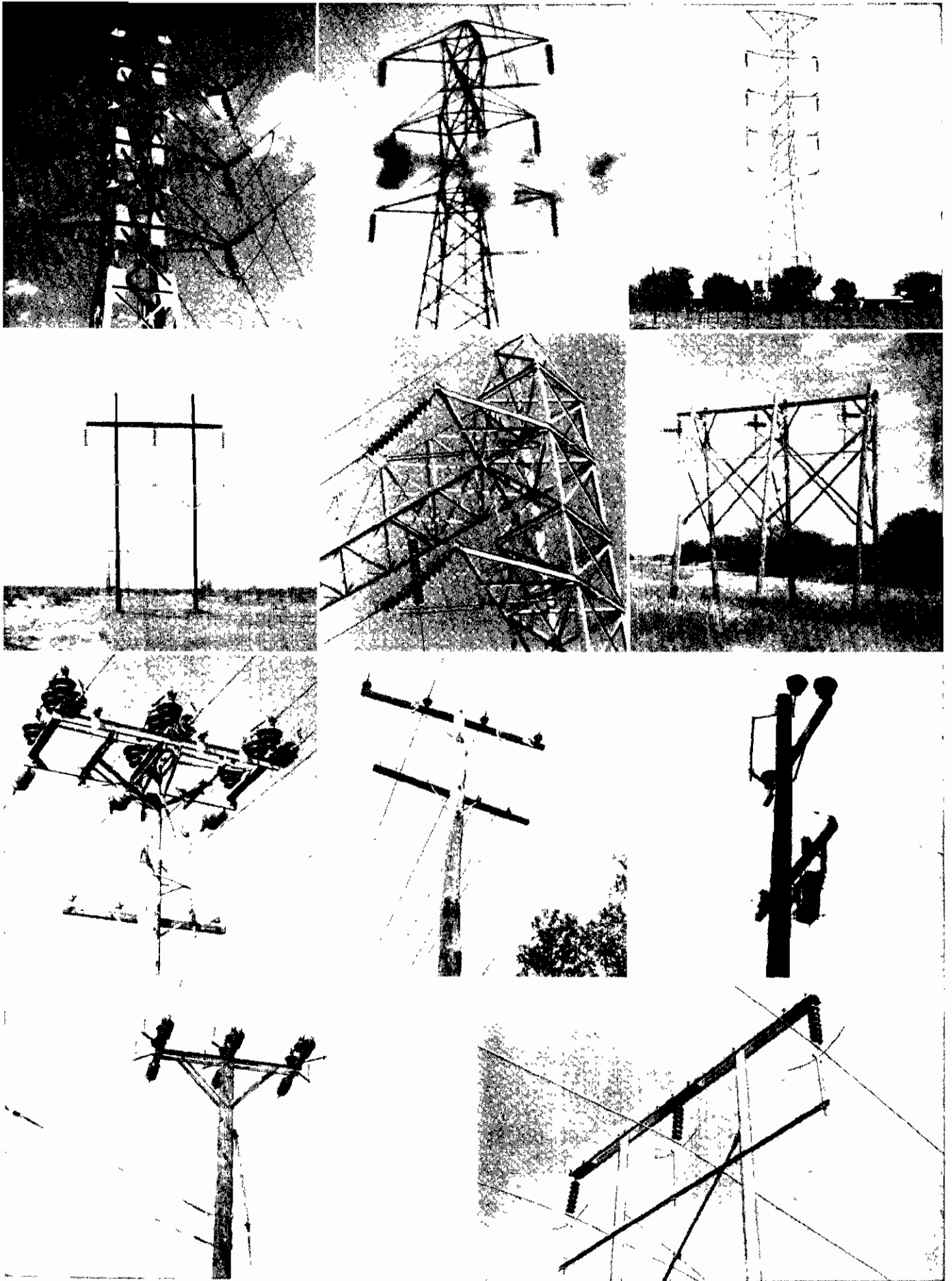

Fig. 41—Mounting details for a number of installations of protector tubes.

20. Determination of Tower Ground Resistance and of the Counterpoise Necessary to Reduce It to a Predetermined Value, by Merrill DeMerit, E.E.I. Publication No. F6.
21. The Counterpoise, by L. V. Bewley, E.E.I. Publication No. F6.
22. Suspension Insulator Assemblies, J. J. Torok, C. G. Archibald, *A.I.E.E. Transactions*, V. 51, September 1932, pages 682-89.
23. Comparison of Protector Tubes and Ground Wires for 66 Kv., by E. P. Naney, *The Electric Journal*, V. 35, August 1938, pp. 301-305.
24. Lightning Strength of Wood in Power Transmission Structures by Philip Sporn and J. T. Lusignan, Jr., *A.I.E.E. Transactions* V. 57, February 1938, pp. 91-101.
25. Protector Tubes for Power Systems, by H. A. Peterson, W. J. Rudge, Jr., A. C. Monteith, and L. R. Ludwig, *A.I.E.E. Transactions*, V. 59, May 1940, pp. 282-288.
26. Experience with Protector Tubes, by E. Wisco and A. C. Monteith, *The Electric Journal*, Aug. 1938, pp. 299-300.
27. 132-Kv Line Modernized Economically with Protector Tubes, by E. W. Hatz, *Electric Light and Power*, December 1939, p. 43.
28. *Symmetrical Components* (a book), by C. F. Wagner and R. D. Evans, McGraw-Hill Book Company, 1933.
29. System Recovery Voltage Determination by Analytical and A-C Calculating Board Methods, by R. D. Evans and A. C. Monteith, *A.I.E.E. Transactions*, V. 56, June 1937, pp. 695-705.
30. Recovery-Voltage Characteristics of Typical Transmission Systems and Relation to Protector-Tube Applications, by R. D. Evans and A. C. Monteith, *A.I.E.E. Transactions*, V. 57, August 1938, pp. 432-440.
31. Voltage-Recovery Characteristics of Distribution Systems, R. L. Witzke, *A.I.E.E. Technical Paper* 49-53, 1949.

INSULATION COORDINATION

Original Authors:

A. C. Monteith and H. R. Vaughan

Revised by:

A. A. Johnson

INSULATION coordination is the correlation of the insulation of electrical equipment and circuits with the characteristics of protective devices such that the insulation is protected from excessive overvoltages. Thus in a substation the insulation of transformers, circuit breakers, bus supports, etc. should have insulation strength in excess of the voltage levels that can be provided by protective equipment such as lightning arresters and gaps. The determination of the economic relationship between the impulse strength of equipment insulation and protective voltage level provided by protective devices has received and continues to receive a great amount of study.

The basic concept of insulation coordination is illustrated in Fig. 1. Curve A is the demonstrated impulse strength of the insulation on a piece of electrical equipment which in operation is exposed to the hazards of lightning surges. Curve B is a protective level afforded by a valve type lightning arrester. Thus any insulation having a withstand voltage strength in excess of the insulation strength of

been made during the past 20 years in improving the design of power systems and equipment with the result that failure of major electrical equipment insulation is rare.

The problem of providing insulation properly coordinated with protective devices involves not only guarding the equipment insulation, but also the protection of the devices themselves. To prevent damage to an arrester or a protector tube, each should be applied on a system in such a way that it will discharge the excessive voltage safely to ground after which it will cease to carry current to ground. Thus the arrester or tube must protect the equipment insulation and be capable of restoring itself as an insulator against whatever system voltages might exist across it to ground. The voltage to ground is determined for a system of given voltage largely by the method used for system grounding, the maximum voltage to ground usually being during the existence of a phase-to-ground fault. Rod gaps do not seal off after being flashed over and therefore the circuit must be disconnected from the system to clear gap breakdowns.

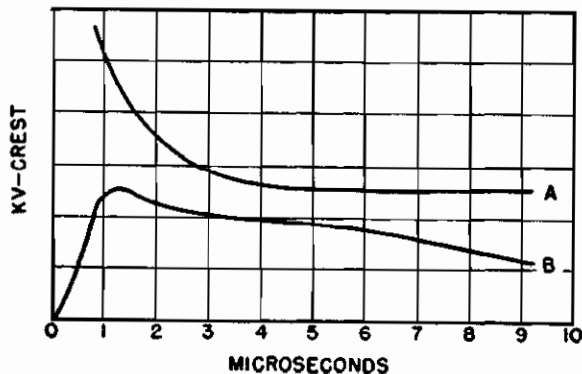

Fig. 1—Protection of insulation with characteristic of "A" by protective device with characteristic of "B."

Curve A is protected by the protective device of Curve B. To protect insulation from excessive voltages the protective device must have a lower breakdown voltage.

The insulation of electrical equipment in a station or substation is subject from time to time to momentary overvoltages that may be caused by system faults, switching surges or lightning surges. Except for special cases, overvoltages caused by system faults or switching do not cause damage to equipment insulation although they may be detrimental to protective devices. Overvoltages caused by lightning are of sufficient magnitude to flashover or breakdown equipment insulation and are therefore the most troublesome and of greatest concern to the manufacturers and operators of electrical equipment. Great strides have

I. HISTORY

Coordination of insulation was not given serious consideration until after the first World War, mainly because of lack of information on the nature of lightning surges and the surge strength of apparatus insulation. Since concrete data were lacking on the actual surge strength of insulation or the discharge characteristics of protective equipment, early attempts at coordination were rule-of-thumb methods based on experience and individual ideas. The result was that some parts of the station were over-insulated while others were under-insulated. Also, the gradual increasing of line insulation in an attempt to prevent line flashovers subjected the station equipment to more severe surges; and in many cases line flashovers were eliminated at the expense of apparatus failures. Growth of power systems, demands for improved power service, and more economical system operation focused more and more attention on the problems of surge voltages, adequate insulation, and its protection.

Thus during the period from about 1918 to 1930 considerable work was done by individual investigators and laboratories in collecting data on natural lightning and in developing insulation testing methods and technique. Although progress was seemingly slow, it resulted in a fair knowledge of the nature of lightning surges and the establishment of universal surge producing and measuring devices. Very little correlation between laboratories was attempted during that period.

In 1930, the NEMA-NELA Joint Committee on Insu-

lation Coordination was formed to consider laboratory testing technique and data, to determine the insulation levels in common use, to establish the insulation strength of all classes of equipment, and to establish insulation levels for various voltage classifications. After ten years of study and collection of data this schedule was fairly well completed. Numerous articles in trade magazines show the results. In a report dated January 1941¹, the committee, now known as the Joint AIEE-EEI-NEMA Committee on Insulation Coordination, rounded out the program by specifying basic impulse insulation levels for the different voltage classifications.

Test specifications for apparatus are prepared on the basis of demonstrating that the insulation strength of the equipment will be equal to or greater than the selected basic level and the protective equipment for the station should be chosen to give the insulation meeting these levels as good protection as economically justified.

II. BASIC INSULATION LEVELS

Several methods of providing coordination between insulation levels in the station and on the line leading into the station^{2,3} have been offered. The best method is to establish a definite common level for all the insulation in the station and bring all insulation to or above this level. This limits the problem to three fundamental requirements, namely, the selection of a suitable insulation level, the assurance that the breakdown or flashover strength of all insulation in the station will equal or exceed the selected level, and the application of protective devices that will give the apparatus as good protection as can be justified economically.

Data collected from utility systems during the early work on insulation coordination provided existing insulation levels. The data collected (60-cycle wet flashover characteristics measured in terms of equivalent gap spacing) fell within well defined limits. The upper limit corresponded to about ten times E_n at the upper end of the curve and to about six times E_n at the lower end of the curve, E_n being the system voltage-to-neutral. The lower limit lay on a curve about four times E_n for systems 46 kv and below and about three times E_n for systems 69 kv and above. These data together with impulse characteristics of insulation obtained in the field and laboratory provided a basis for establishing insulation levels. Impulse test levels, in terms of inches of gap, were therefore, selected that represented a medium between the upper and lower limits defined above and that fell within the scope of available protective devices. As laboratory technique improved so that different laboratories were in close agreement on test results, the test levels were expressed in kilovolts corresponding to the test gaps, based on a $1\frac{1}{2} \times 40$ microsecond positive wave, which is illustrated in Fig. 5(a). The basic levels were expressed on a 50–50 flashover basis, that is, values in kv crest corresponding to gap spacings giving 50 percent flashover and 50 percent full wave when subjected to $1\frac{1}{2} \times 40$ positive impulse. Recognizing that it was not practical to subject most types of apparatus to a series of flashover tests to demonstrate their insulation levels, a minus tolerance of five percent was allowed in the definition of basic levels to permit a practical test

TABLE 1—BASIC IMPULSE INSULATION LEVELS

Column 1	Column 2		Column 3
Reference Class Kv	Standard Basic Impulse Level Kv		Reduced Insulation Levels In Use-Kv
1.2	30*	45†	...
2.5	45*	60†	...
5.0	60*	75†	...
8.7	75*	95†	...
15	95*	110†	...
23		150	...
34.5		200	...
46		250	...
69		350	...
92		450	...
115		550	450
138		650	550
161		750	650
196		900	...
230		1050	900
287		1300	...
345		1550	...

*For distribution class equipment.
†For power class equipment.

demonstration of acceptability of equipment. Finally, in January, 1941¹, the Joint AIEE-EEI-NEMA Committee adopted basic insulation levels (Table 1) in terms of withstand voltages according to the following definition:

“Basic impulse insulation levels are reference levels expressed in impulse crest voltage with a standard wave not longer than $1\frac{1}{2} \times 40$ microsecond wave. Apparatus insulation as demonstrated by suitable tests shall be equal to or greater than the basic insulation level.”

This requires that apparatus conforming to these levels shall have a withstand test value not less than the kv magnitude given in the second column of Table 1. It was also understood that apparatus conforming to these requirements should be capable of withstanding the specified voltage whether the impulse is positive or negative in polarity. Atmospheric conditions at time of test should be taken into consideration.

The values in Table 1, column 2 were selected initially as the standard basic impulse insulation levels (BILs) to be applied regardless of how the system was grounded. Systems ungrounded or grounded so as to allow full displacement of the neutral during line-to-ground faults require lightning arresters based on the full line-to-line voltage of the system. If the system is grounded solidly or so as to limit the line-to-ground voltage during ground faults ($X_0/X_1 \leq 3$) the so called 80-percent arrester can and has been used. Thus in some of the voltage classes of 115 kv and above a number of systems have used, with solid grounding, equipment having insulation with BILs one class lower, as shown in Table 1, column 3.

On some solidly-grounded systems where the ratio X_0/X_1 is equal to about one or less, the one class lower BIL has

been used with 75 percent arresters with satisfactory experience. As a result of this experience, better overall understanding of the problem, and the economy of reducing BIL in the higher voltage classes, particularly on transformers, the Joint AIEE-EEI-NEMA Committee on Insulation Coordination is studying the possibility of reducing the BIL figures (for $X_0/X_1 \leq 1.0$) to lower values than those shown in Table 1, column 3. Another reason for giving serious consideration to reducing the BIL for solidly-grounded systems is that there are many old transformers in service with insulation levels below that given in Table 1, column 3 which have given twenty or more years of service without failure. Thus, since the first group of BILs was adopted in 1941, the manner in which the system is grounded has been brought into the picture with the result that lower BIL equipment can be protected, thereby enabling systems to be built to do the same job at less cost.

1. Selection of Basic Impulse Insulation Level

The basic impulse insulation level should be selected which can be protected with a suitable lightning protective device. The best protection is provided by modern type lightning arresters. The spread or margin between the BIL and the protective device, allowing for manufacturing tolerances, is an economic consideration that must balance the chances of insulation failure against the cost of greater insulation strength. When using lightning arresters the economic factor may be one of greater risk to the arrester than to the equipment insulation. The arrester can be applied so that it will protect the insulation but may under certain extreme conditions, usually unlikely, be subjected to sustained rms overvoltages against which it cannot recover. Practice has been to apply arresters so that they have an rms voltage rating of at least five percent above the maximum possible rms line-to-neutral voltage under any normal or expected fault condition. The BIL of the equipment insulation must therefore be higher than the maximum expected surge voltage across the selected arrester.

To illustrate one method for selecting the BIL of a transformer to be operated on a 138-kv system, assume the transformer is of large capacity and wye connected on the 138-kv side. The transformer is solidly grounded and the impedance ratios at the transformer terminals are such that $X_0/X_1=2.0$; $R_0/X_1=1.0$, $R_1/X_1=0.1$, $R_1=R_2$ and $X_1=X_2$. For these conditions the maximum voltage to ground at the transformer terminals during any type of system fault for any fault resistance is 74 percent of normal phase-to-phase voltage as obtained from Fig. 29 (b). Allowing five percent for system overvoltage, the arrester rms voltage rating should be $(1.05)(74)$ or 77.7 percent which is $(77.7)(138)$ or 107.2 kv. Thus an arrester of 109 kv, which is the closest standard rating, would be required. Curve A in Fig. 2 is the characteristic of a 109-kv station valve-type arrester for an assumed 10×20 microsecond wave of 5000 amperes and a plus tolerance of 15 percent on the average impulse sparkover and a plus tolerance of 10 percent above the average drop across the arrester. Assuming a 15 percent margin plus 35 kv between the 400 kv and the required BIL of the transformer insu-

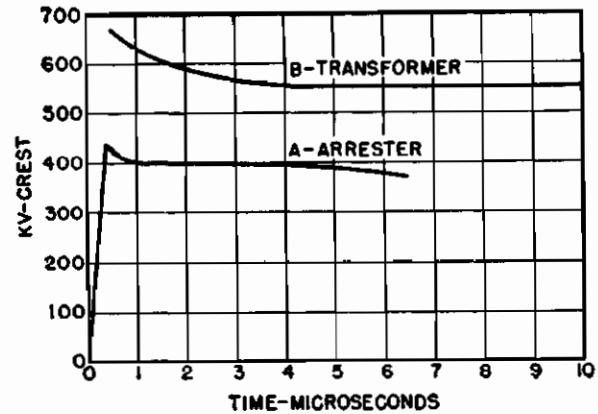

Fig. 2—Coordination of transformer insulation with arrester characteristic.

Curve A—109-kv station-type SV arrester—maximum voltage for 5000-ampere 10×20 current wave.

Curve B—Transformer insulation withstand characteristic.

lation gives 495 kv. Since this value is under the standard of 550 kv, this value can be applied as shown on Curve B of Fig. 2. Based on the recommended application values for voltage drop across the 109-kv arrester for a 5000-ampere surge 388 kv instead of 400 kv can be used, which gives additional margin of protection in 95 percent of the cases.

Direct lightning strokes in general have a high rate of voltage rise (1000 to 10 000 kv per microsecond) and high current values (5000 to 200 000 amperes). Such strokes may occur at any point on exposed structures whether they are lines or stations. The severity of the surges on station insulation and protective devices largely depends on whether or not adequate shield wires are placed above the structures to intercept the lightning and conduct it to ground. Without overhead ground wires at stations, direct strokes may damage protective devices, thus leaving equipment insulation without adequate protection. Surges that originate as direct strokes on the line and propagate into a station are by far the most common, but are generally easily by-passed to ground by the lightning-protective device. Overhead ground wires above open-wire circuits reduce the number of strokes that reach the phase conductors as discussed in Chapter 17.

The nature of lightning strokes and the propagation of surges are explained in detail in Chaps. 15 and 16. The characteristics of traveling surges at the station depend upon the nature of the direct stroke as it originates on the phase conductors, the distance between origin and station, the insulation and electrical characteristics of the line, and the capacitance of the equipment in the station. The surge is attenuated as it travels by corona loss and skin effect, and is distorted by reflection at the station. The capacitance of the station equipment charged through the inductance of the line from the point where the surge originates to the station has the effect of sloping off the front of the surge wave.

The magnitude of the surge voltage that can be impressed on electrical equipment is not determined by the system operating voltage so there is some argument against

associating impulse levels directly with operating voltages. However, low-voltage lines are not as highly insulated as higher voltage lines so that lightning surges coming into the station would normally be much less than in a higher voltage station because the high-voltage surges will flash over the line insulation and not reach the station. Also, the lower operating voltage permits the use of protective devices with lower discharge characteristics. The insulation necessary for high operating voltages inherently provides high impulse strength. The impulse levels shown in Table 1, therefore, can be obtained with the corresponding operating voltage class without exceeding reasonable design proportions.

III. SURGE TESTING

The determination of the impulse strength of the various insulations is generally done by an adaptation of the surge generator devised by Dr. Emil Marx in Germany. It consists essentially of a group of condensers, spark gaps, and resistors so connected that the condensers are charged in parallel from a relatively low-voltage source and discharged in series to give a high voltage across the test piece.

The only oscillograph available until quite recently for measuring waves of as short duration as lightning surges was the cathode-ray oscillograph devised by Dufour. This oscillograph was improved by Norinder through the addition of a simple cathode-ray beam control, and today this oscillograph is widely used in this country and others. In

the Norinder device, the wave shape is recorded on the film in its entirety.

A typical diagram of impulse-testing equipment is shown in Fig. 3. The capacitors, usually rated 100 kv each, making up the surge generator are charged in parallel through resistors. When the charge on each condenser reaches the predetermined breakdown voltage of the sphere gaps separating the condensers, the sphere gaps flash over thereby connecting all the condensers in series. One terminal of the capacitor bank is normally grounded. The other terminal must be insulated from ground to withstand the full magnitude of the discharge voltage. A voltage impulse of either positive or negative polarity can be obtained by connecting the charging circuit to give the desired polarity. The potential divider shown supplies a reduced voltage to the oscillograph proportional to the test voltage.

The shape of the impulse wave applied to the test specimen is determined by the constants (resistance, inductance, and capacitance) of the discharge circuit, some of which are inherent in the capacitors and leads and some of which are added externally. A typical laboratory installation of impulse-testing equipment is shown in Fig. 4.

2. Wave Shape

It became evident in the early stages of surge testing that it would be necessary to standardize on test wave forms in order to establish insulation levels on a common basis. The accepted designation of defining the impulse

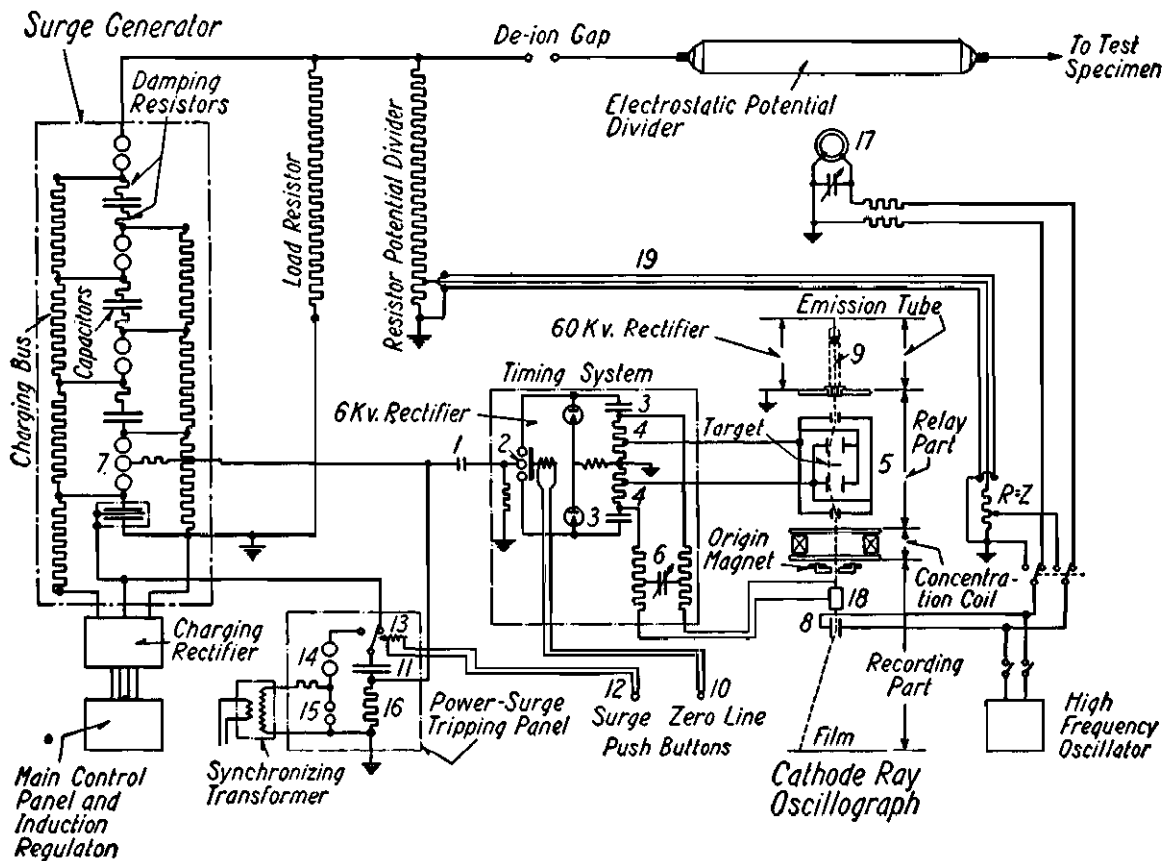

Fig. 3—Typical diagram of impulse testing equipment.

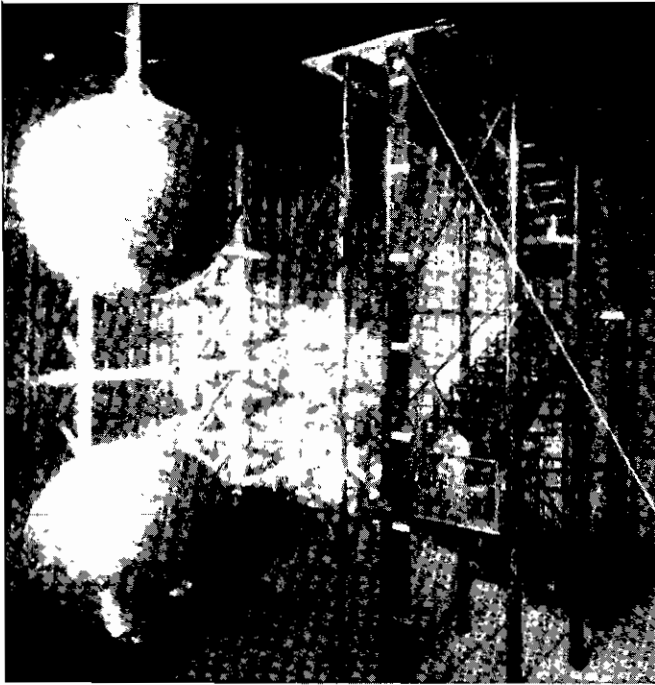

Fig. 4—Typical impulse laboratory. Sharon Works of Westinghouse Electric Corporation.

wave shape is to give the time in microseconds for the impulse to reach crest followed by the time in microseconds for the wave to reach half magnitude. Fig. 5 (a)⁴.

For practical reasons a virtual zero time point is established at O_1 and determined by a line drawn through the $0.3E$ and $0.9E$ points in the wave front. For example, a $1\frac{1}{2} \times 40$ microsecond wave would have an O_1x_1 value of $1\frac{1}{2}$ microseconds and an O_1x_4 value of 40 microseconds. In transformer testing where the time to crest is not easily determined, it is taken as two times the interval between the $0.3E$ and $0.9E$ points on the wave front, that is $2x_2x_3$.

The 1×5 and 1×10 microsecond waves, and other wave shapes, have been used occasionally in testing insulation.

However, the $1\frac{1}{2} \times 40$ microsecond wave, either positive or negative, has now been accepted as standard because it simulates the more severe full wave lightning surges and because it can be obtained readily with the surge generator. The effect of lightning surges of shorter duration can be simulated with this wave by chopping at short times.

3. Volt-Time Curve

The breakdown voltage of insulation or the flashover voltage of a gap, particularly the latter, will vary with the length of time voltage is applied. The so-called volt-time curve is a graph of crest flashover voltages plotted against time to flashover for a series of impulse applications of a given wave shape. The construction of the volt-time curve and the terminology associated with impulse testing are shown in Fig. 5 (b)⁴. The critical or minimum flashover voltage is the crest voltage of the wave that will just cause flashover on the tail of the wave, that is, it will cause flashover for 50 percent of the applications, and for the other 50 percent of the applications there will be a full wave (no flashover).

The figure also shows the relation of the critical withstand voltage. To obtain the magnitude of the voltage, the applied voltage is reduced to just below the disruptive discharge of the test specimen. The rated withstand voltage is the crest value of the impulse wave that the apparatus will stand without disruptive discharge.

4. Effect of Atmospheric Conditions

The flashover characteristics of insulation in air varies with atmospheric conditions. In general, flashover voltages vary inversely with temperature, directly with barometric pressure, and directly with absolute humidity. Test data obtained under various actual weather conditions are usually corrected to the American standard conditions which are:

Temperature, 77°F.

Barometric pressure, 29.92 inches of mercury

Humidity, 0.6085 inches of mercury

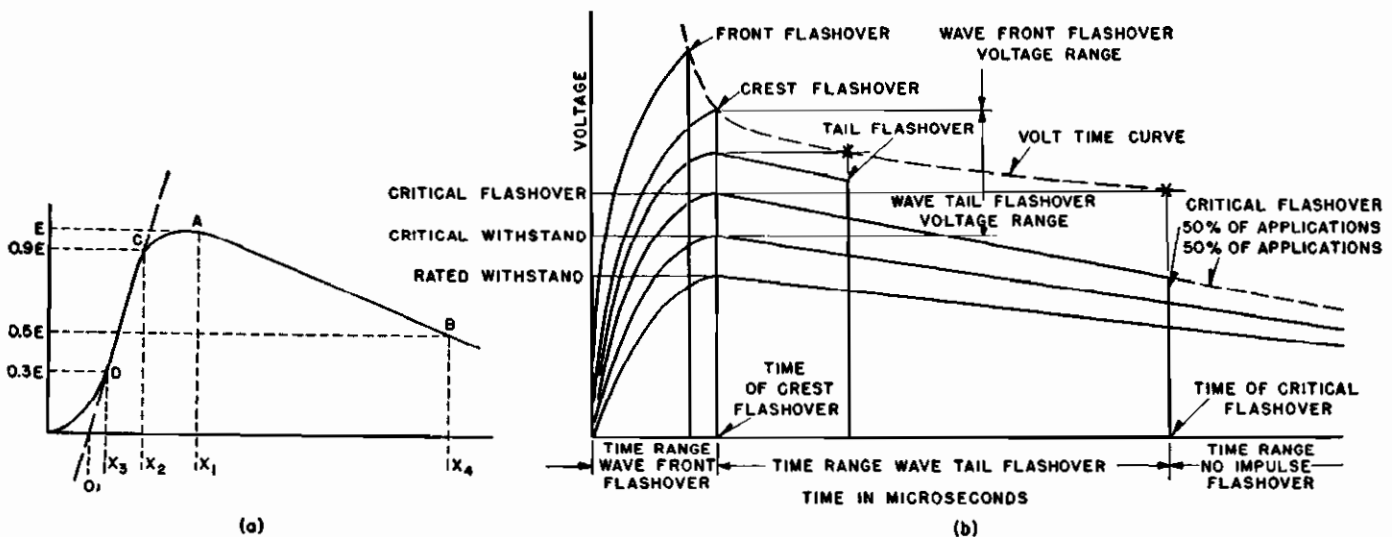

Fig. 5—Wave shape.

(a) An impulse testing wave illustrating methods of designating significant characteristics of the wave. (b) Series of impulse waves illustrating the terminology and definitions associated with impulse voltage testing.

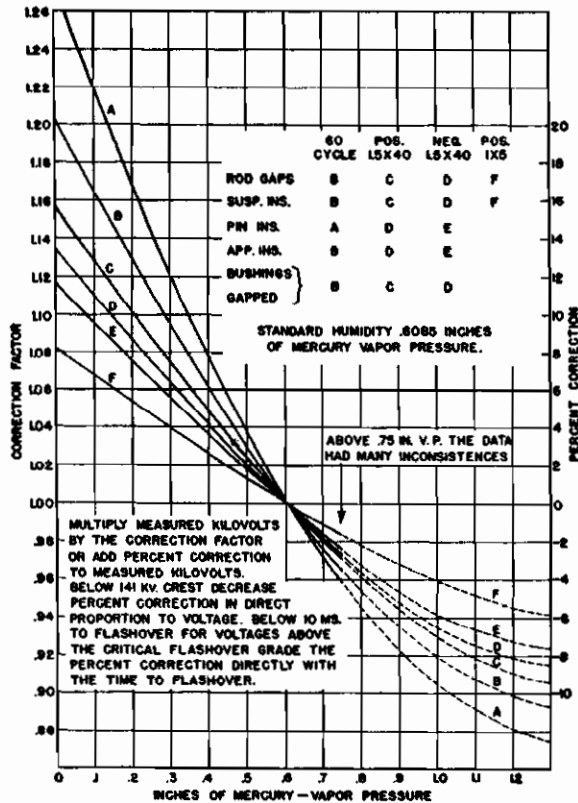

Fig. 6—Humidity correction factors for flashover voltages of gaps, insulators and bushings, based on data from several laboratories.

Temperature and barometric pressure are usually combined into a single factor known as relative air density according to the following relation which is unity for standard atmospheric conditions:

$$\text{Relative Air Density} = \frac{17.95 \times \text{Bar. Pressure (inches)}}{460 + \text{Temp. } ^\circ\text{F.}}$$

The chart shown in Fig. 6⁴ has been accepted, based on an accumulation of test data, as giving correction factors for humidity conditions. The measured test voltage is then corrected by dividing by the relative air density defined above and multiplying by the humidity factor obtained from these curves.

TABLE 2—TENTATIVE AIEE STANDARD ON INSULATION TESTS FOR INDOOR AIR SWITCHES, INSULATOR UNITS AND BUS SUPPORTS Withstand Voltage—Kv

Voltage Rating	Low Freq. 1 Min. Dry	Impulse 1.5×40 Full Wave (Pos. or Neg. Dry)
2.5	15	45
5.0	19	60
7.5	26	75
15 L*	36	95
15 H	50	110
23	60	150
34.5	80	200

*The 15 L rating is intended to match other apparatus on which the 36-95 test level is specified.

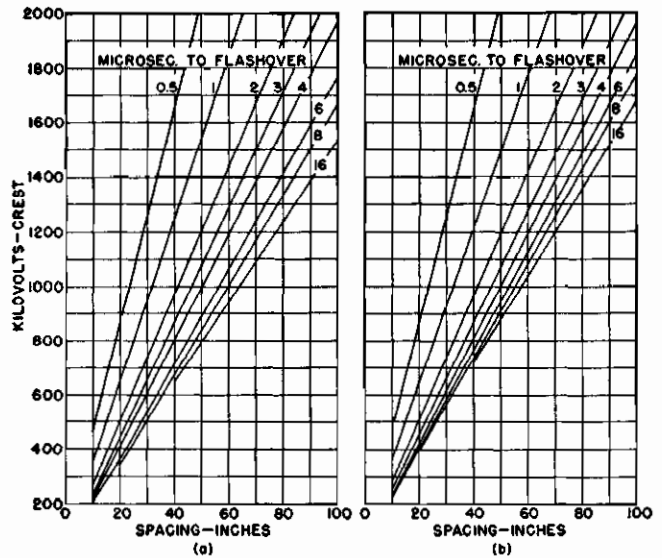

Fig. 7—Impulse flashover characteristics of standard rod gaps. Long spacings for 1½ x 40 wave at 77°F., 30-inch barometric and 0.6085-inch vapor pressure.

- (a) Positive waves.
- (b) Negative waves.

The AIEE-EEI-NEMA Subcommittee on Correlation of Laboratory Data have published a paper giving a summary of recommended standard definitions and methods applying to high-voltage testing⁴. These recommendations are now generally followed by the industry.

5. Flashover Characteristics of Rod Gaps and Insulators

Because of laboratory differences in test results on apparatus insulation in the early days of impulse testing, the rod gap was selected as a yard stick of insulation strength. Because different types of gaps gave different results, a

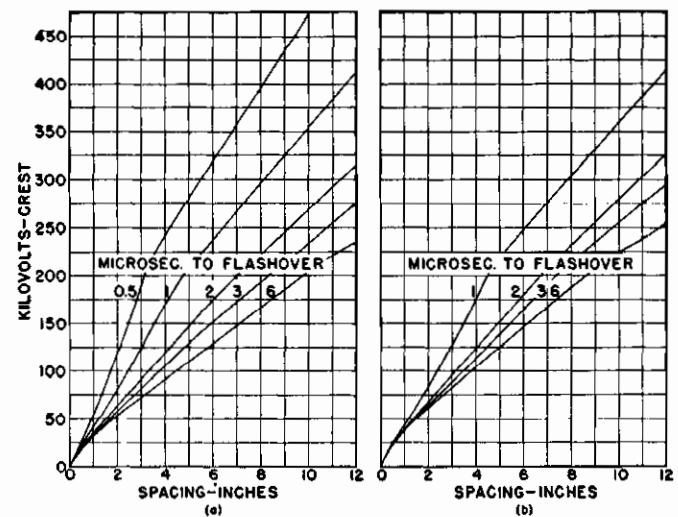

Fig. 8—Impulse flashover characteristics of standard rod gaps. Short spacings for 1½ x 40 wave at 77°F., 30-inch barometric and 0.6085-inch vapor pressure.

- (a) Positive waves.
- (b) Negative waves.

TABLE 3—TENTATIVE AIEE STANDARD ON INSULATION TESTS FOR OUTDOOR AIR SWITCHES, INSULATOR UNITS AND BUS SUPPORTS Withstand Voltage—Kv

Voltage Rating Kv	Low Freq. 1 Min. (Dry)	Low Freq. 10 Sec. (Wet)	Impulse 1.5x40 Full Wave (Pos. or Neg.)
7.5	36	30	95
15	50	45	110
23	70	60	150
34.5	95	80	200
46	120	100	250
69	175	145	350
92	225	190	450
115	280	230	550
138	335	275	650
161	385	315	750
196	465	385	900
230	545	445	1050
287	680	555	1300
345	810	665	1550

standard gap was established. The following defines the standard rod gap⁶.

“The rod gap shall consist of two, 0.5 inch square-cornered square-cut rods spaced co-axially and overhanging their supports at least one-half the gap spacing. The rods shall be mounted on standard apparatus insulators giving a height of gap above the ground plane of 1.3 times the gap spacing plus four inches, with a tolerance of ±10 percent.”

Laboratory technique is now developed to the point that apparatus insulation levels can be expressed in terms of voltage. However, the rod gap is still sometimes used

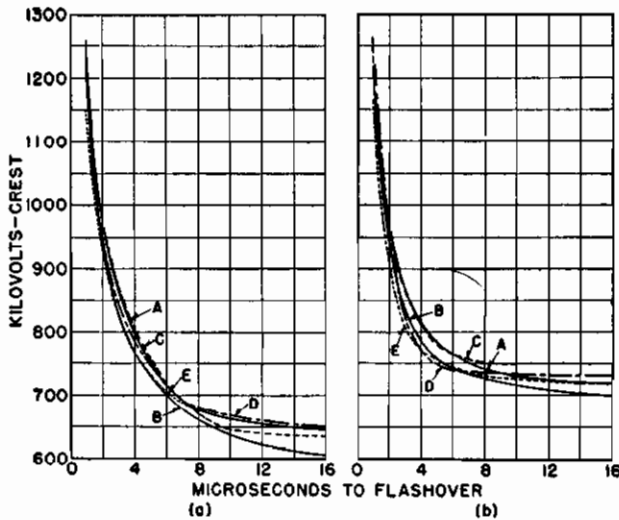

Fig. 9—Impulse flashover characteristics of 40-inch standard and vertical rod gaps, wet and dry, for 1½ x 40 waves, water 0.2 in. per min., 1350 ohms per cubic inch.

- (a) Positive waves.
- (b) Negative waves.
- A—Average curve for standard rod gaps.
- B—Test curve for 40-inch standard gap.
- C—Standard gap, wet test.
- D—Vertical gap.
- E—Vertical gap, wet test.

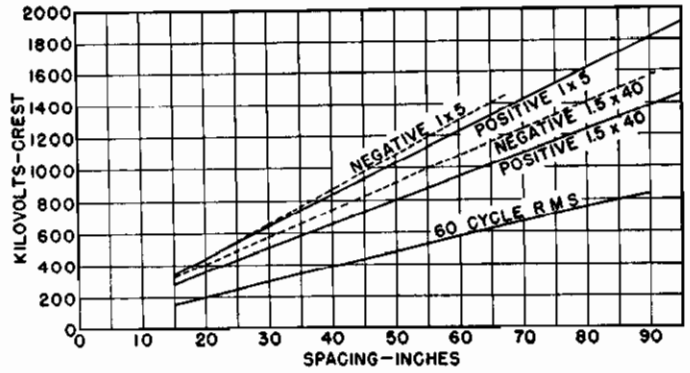

Fig. 10—Sixty-cycle and critical impulse flashover voltages of standard rod gaps, averaged by the AIEE, EEl, NEMA Subcommittee from results of tests from several laboratories.

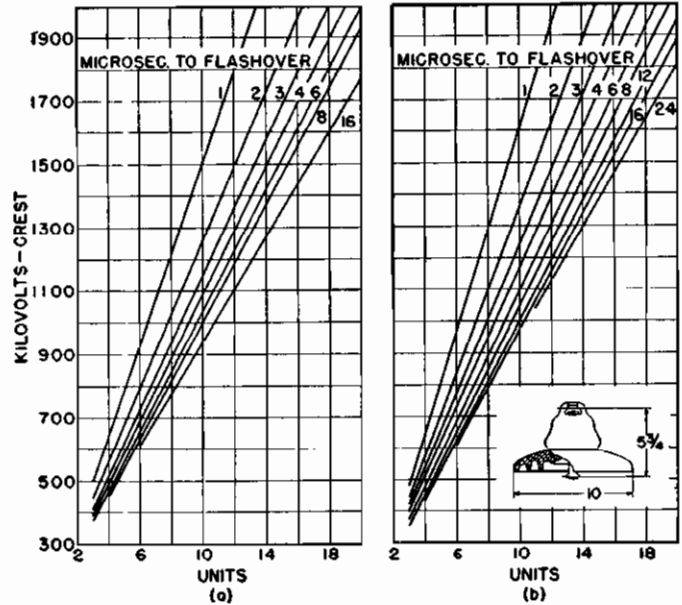

Fig. 11—Impulse flashover characteristics of suspension insulators for 1½ x 40 waves at 77°F., 30-inch barometric and 0.6085-inch vapor pressure. Relative air density = 1.0.

- (a) Positive waves.
- (b) Negative waves.

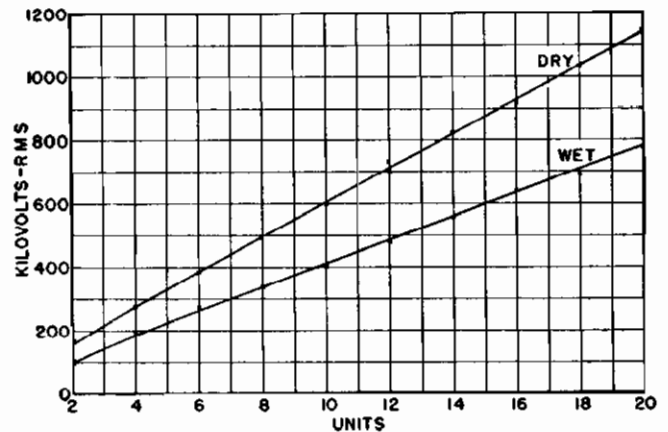

Fig. 12—Sixty-cycle flashover of suspension insulators shown in Fig. 11.

- Dry: relative air density = 1.0. humidity = 0.6085.
- Wet: precipitation = 0.2 in. per min. resistance of water = 7000 ohms per cubic inch.

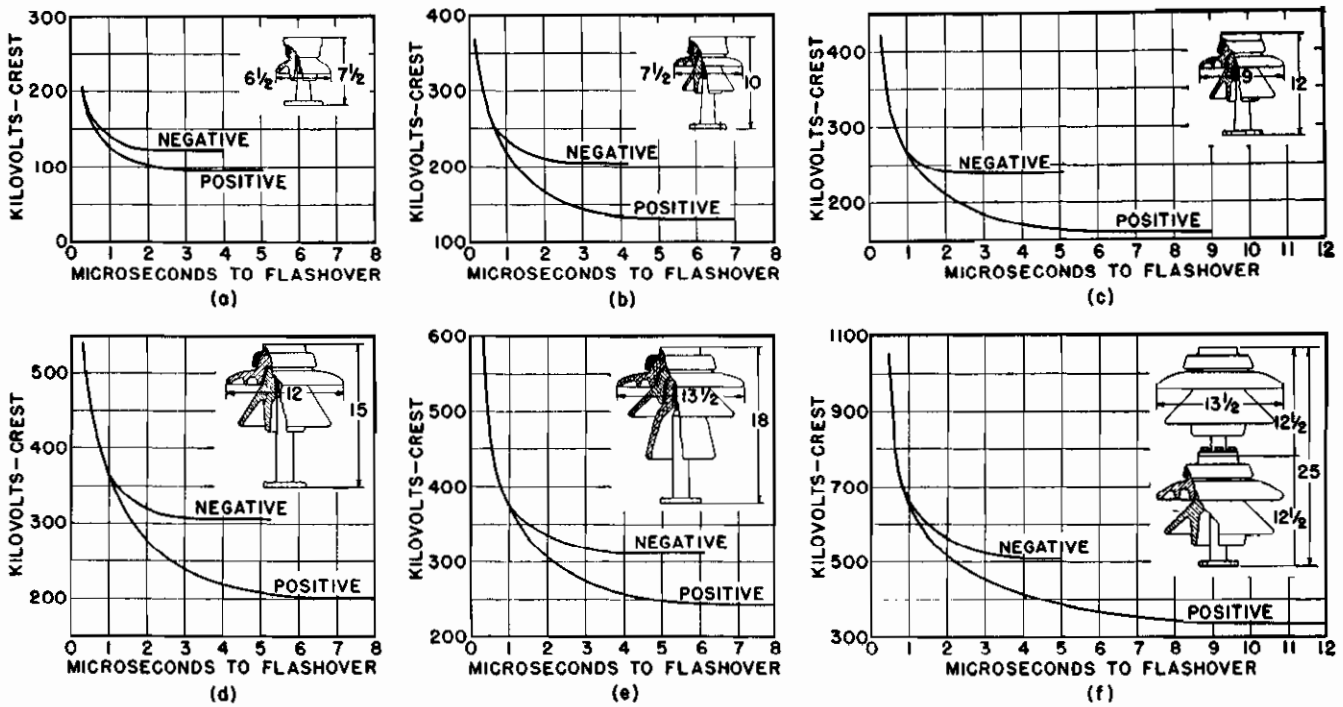

Fig. 13—Impulse flashover characteristics of particular types of apparatus insulators on positive and negative $1\frac{1}{2} \times 40$ waves at standard air conditions.

- (a) 7.5 kv class.
- (c) 23 kv class.
- (e) 46 kv class.
- (b) 15 kv class.
- (d) 34.5 kv class.
- (f) 69 kv class.

so that information on its flashover characteristics is useful.

Suspension and apparatus insulators play an important part in the coordination of station equipment, not only in establishing the insulation level but also in determining the magnitude of surges entering the station. Suspension insulators are generally made up of at least three ten-inch units in a string, spaced $5\frac{3}{4}$ inches apart. Apparatus insulators can be either the pedestal type or the so-called post type.

A complete résumé of impulse and 60-cycle flashover characteristics of rod gaps and insulators was published by P. H. McAuley⁶. For convenience some of these data are reproduced in Figs. 7 to 17. Figure 9 is of particular interest in that it shows the effect of mounting and atmospheric conditions on the flashover characteristics of rod gaps.

The voltage distribution across strings of standard sus-

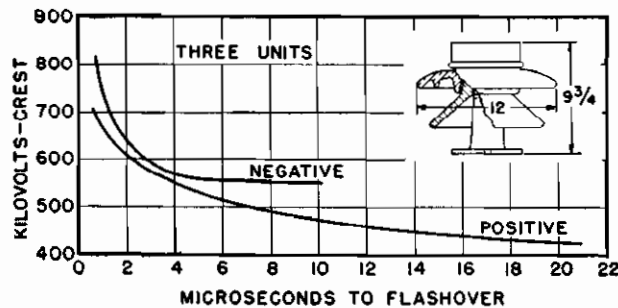

Fig. 14—Impulse flashover characteristics for 88 kv class, 3-unit column for positive and negative $1\frac{1}{2} \times 40$ waves at standard air conditions.

pension insulators of various lengths is given in Fig. 18. The data for 10 to 18 insulators were obtained by laboratory tests by Sorensen^{25, 26}.

Table 2 gives data from a Tentative AIEE standard on the 60-cycle and impulse withstand characteristic for indoor air switches, insulator units and bus supports. Table 3 gives similar data for corresponding outdoor insulation.

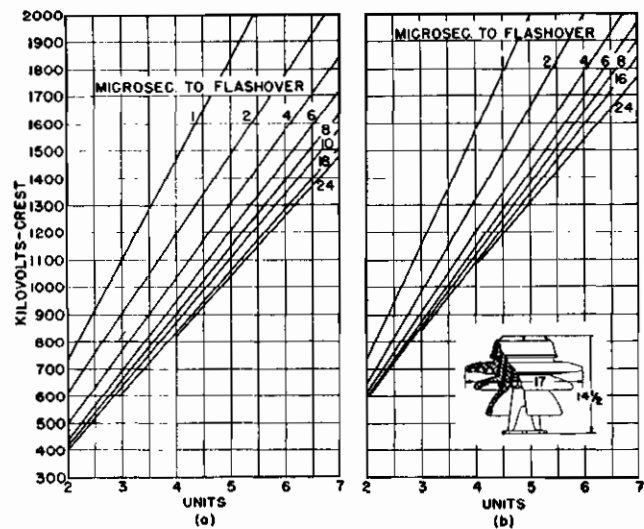

Fig. 15—Impulse flashover characteristics of two to seven units, apparatus insulators, for $1\frac{1}{2} \times 40$ waves at standard air conditions.

- (a) Positive waves.
- (b) Negative waves.

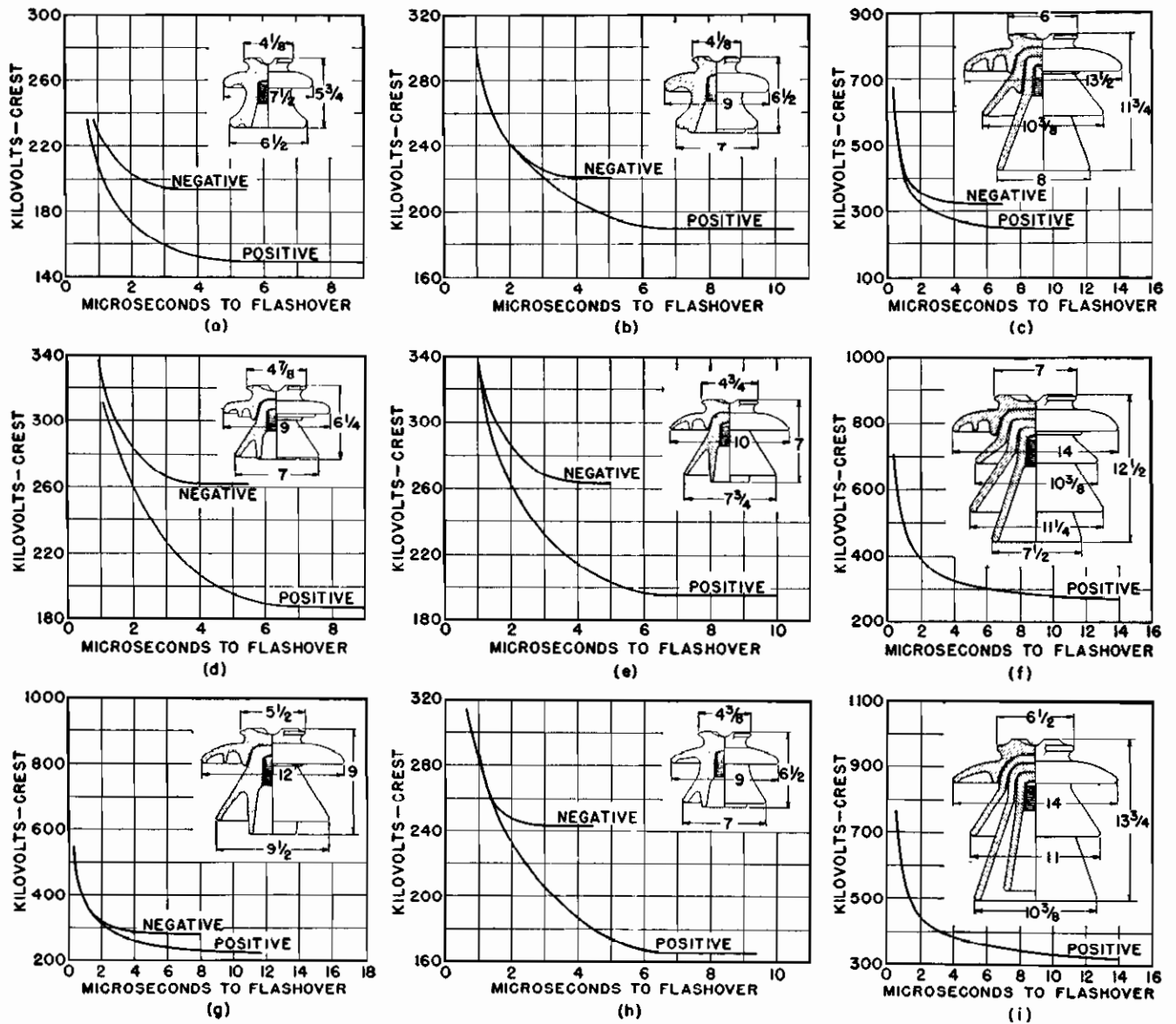

Fig. 16—Impulse flashover characteristics of particular sizes of pin type insulators for positive and negative $1\frac{1}{2} \times 40$ waves at standard air conditions.

Since the voltage-time curves for various types of insulators are not available from the standards, the curves in Figs. 13, 14, 15, 16, and 17 are given even though some

of the insulators shown do not meet the required impulse withstand voltage.

6. Impulse Characteristics of Transformer Insulation

Because a power transformer is usually the most expensive equipment in a station and because its failure may mean a lengthy and costly outage, it is investigated most critically from an insulation standpoint.

The impulse level of a transformer can be determined by the breakdown voltage of the major internal insulation (insulation to ground), the breakdown voltage of the minor insulation (insulation between turns and windings), and the flashover voltage of the bushings, or a combination of these. The impulse characteristic of the internal insulation in a transformer differs from flashover in air in two main respects. First of all, the impulse ratio (the ratio of minimum breakdown on impulse to breakdown on 60-

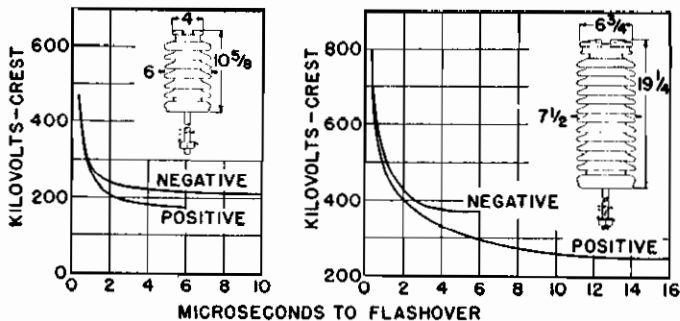

Fig. 17—Impulse flashover characteristics of line-post insulators for positive and negative $1\frac{1}{2} \times 40$ waves at standard air conditions.

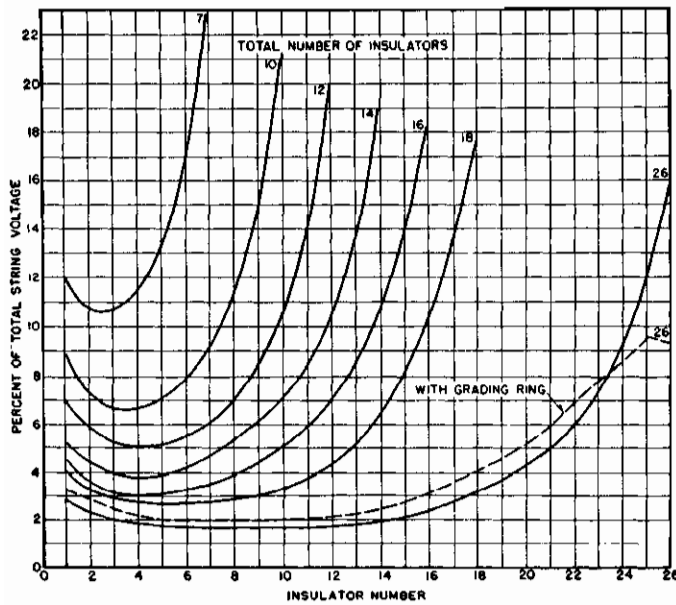

Fig. 18—Power-frequency voltage across each unit in an insulator string starting with insulator No. 1 on the grounded end of the string. Insulator No. 5 in a string of 10 has 7 percent of the total string voltage. (Without grading rings except where noted.)

cycle peak) is higher, being from 2.1 to 2.2 for transformer insulation, whereas, it is 1.5 or less for rod gaps, insulators, bushings, etc. Secondly, the impulse breakdown of transformer insulation does not vary as much with time as seen from a typical volt-time curve, shown in Fig. 19⁷. After three microseconds the breakdown voltage is substantially constant.

The insulation stress between turns or between coils in a transformer is dependent largely upon the steepness of the surge wave front. It may be further aggravated by oscillations within the transformer or by a "piling up" of the surge voltage in a small portion of the winding. (See Fig. 20⁷.) Modern transformers are designed, however, so

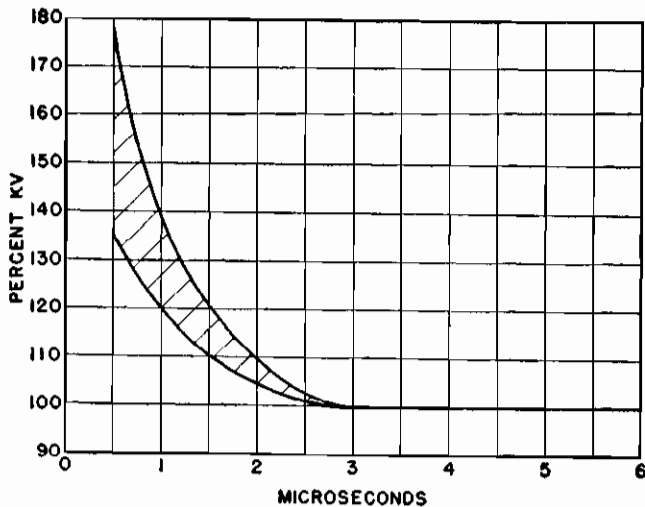

Fig. 19—Volt-time curve of typical major insulation in transformers.

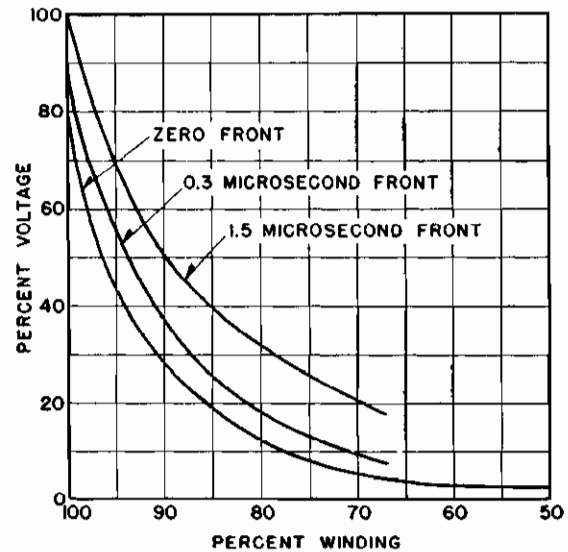

Fig. 20—Effect of wave front on initial voltage distribution in some types of transformer windings.

that the minor insulation meets all the requirements of applied impulse tests. To demonstrate this, modern transformers usually must be capable of passing a chopped wave test of a higher voltage crest than the full wave test. This chopped wave is produced by flashover of a gap or bushing in parallel with the transformer insulation. The standard impulse tests for transformers, regulators, and reactors for the different voltage classifications as standardized by the American Standards Association C 57 are as follows:

Standard impulse tests consist of two applications of a chopped wave followed by one application of a full wave. Either positive or negative waves may be used.

(a) Chopped-Wave Test

- (1) For this test, the applied voltage wave shall have a crest voltage and time to flashover in accordance with Table 4.
- (2) The chopped wave shall be obtained by flash-over of a suitable air gap.

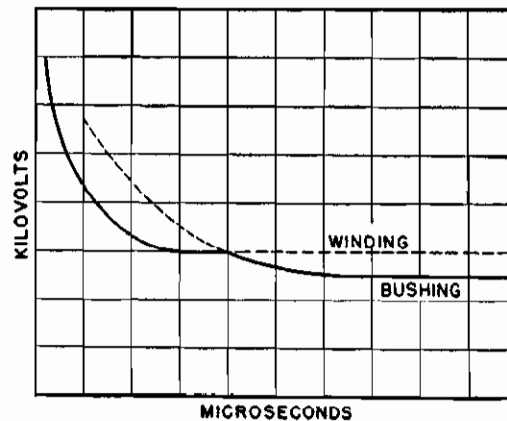

Fig. 21—Typical volt-time curve of transformer winding and bushing (heavy solid line represents the overall volt-time curve of transformer, to be used when protecting against lightning surges).

TABLE 4—STANDARD IMPULSE TESTS FOR TRANSFORMERS, REGULATORS, AND REACTORS

Insulation Class—Kv	Impulse Tests					
	Oil-Type Transformers 500 Kva or Less—Oil-Type Instrument Transformers—Oil-Type Constant-Current Transformers—Step and Induction Voltage Regulators 250 Kva or Less Single-Phase and 750 Kva or Less Three-Phase			Oil-Type Transformers over 500 Kva—Oil-Type Regulating Transformers—Oil-Type Current Limiting Reactors—Step and Induction Voltage Regulators Over 250 Kva Single-Phase and Over 750 Kva Three-Phase		
	Chopped Wave		Full Wave	Chopped Wave		Full Wave
	Kv Crest	Min Time to Flash-over in Micro-seconds	Kv Crest	Kv Crest	Min Time to Flash-over in Micro-seconds	Kv Crest
1.2	36	1.0	30	54	1.5	45
2.5	54	1.25	45	69	1.5	60
5.0	69	1.5	60	88	1.6	75
8.66	88	1.6	75	110	1.8	95
15	110	1.8	95	130	2.0	110
25.0	175	3.0	150	175	3.0	150
34.5	230	3.0	200	230	3.0	200
46.0	290	3.0	250	290	3.0	250
69.0	400	3.0	350	400	3.0	350
92	520	3.0	450	520	3.0	450
115	630	3.0	550	630	3.0	550
138	750	3.0	650	750	3.0	650
161	865	3.0	750	865	3.0	750
196	1035	3.0	900	1035	3.0	900
230	1210	3.0	1050	1210	3.0	1050
287	1500	3.0	1300	1500	3.0	1300
345	1785	3.0	1550	1785	3.0	1550

(b) Full-Wave Test

For this test, the applied voltage wave shall have a crest value in accordance with Table 4.

(c) Excitation During Impulse

During the impulse test if the transformer is excited at normal voltage and frequency, the impulse shall be timed within 30 electrical degrees of the crest of the normal frequency voltage of opposite polarity.

The test values for the different voltage classifications are shown in Table 4.

Since the bushing represents a vital portion of the transformer insulation, its impulse flashover must be carefully considered in establishing the transformer insulation levels. The standard withstand voltage tests for apparatus bushings as given in ASA C 76 Standard 1943 are listed in Table 5.

TABLE 5—STANDARD WITHSTAND TEST VOLTAGES FOR APPARATUS BUSHINGS

Insulation Classification (1) KV	Low Frequency Test RMS Kv (2)				Impulse Test 1.5×40 Micro-second Full Wave Crest Kv (2, 4)		
	Outdoor Bushings				Indoor (7) Bushings 1 Min Dry (3)	Indoor (7) Bushings	
	Large Apparatus (5)		Small Apparatus (6)				
	1 Min Dry	10 Sec Wet	1 Min Dry	10 Sec Wet	Large Apparatus (5)	Small Apparatus (6)	
1.2	10	6	..	30	..
2.5	21	20	15	13	20	60	45
5.0	27	24	21	20	24	75	60
8.7	35	30	27	24	30	95	75
15	50	45	35	30	50(8)	110	95
23	70	60	70	60	60	150	150
34.5	95	80	95	80	80	200	200
46	120	100	120	100	..	250	250
69	175	145	175	145	..	350	350
92	225	190	225	190	..	450	450
115	280	230	280	230	..	550	550
138	335	275	335	275	..	650	650
161	385	315	385	315	..	750	750
196	465	385	465	385	..	900	900
230	545	445	545	445	..	1050	1050
287.5	680	555	680	555	..	1300	1300
345	810	665	810	665	..	1550	1550

- (1) Bushings of a given insulation classification are in general recommended for apparatus having a rating up to and including the insulation classification of the bushing and may be used for apparatus of a higher voltage rating when adequate for the particular application.
- (2) All values are withstand test values without negative tolerance.
- (3) Wet test values are not assigned to indoor bushings.
- (4) Either positive or negative waves may be used—whichever gives the lower value.
- (5) Bushings for use in large apparatus are those intended for use in transformers rated above 500 kva, outdoor circuit breakers, and other apparatus of corresponding importance.
- (6) Bushings for use in small apparatus are those intended for use in transformers rated 500 kva and less and other apparatus of corresponding importance.
- (7) Bushings for use in indoor apparatus are those intended for use in indoor type circuit breakers, instrument transformers, and other indoor apparatus except dry-type instrument transformers, air-cooled transformers, air-cooled regulators, and bushings used primarily for mechanical protection of insulated cable leads.
- (8) Bushings for small indoor apparatus may be supplied to withstand a low frequency test of 38 kv and an impulse test of 95 kv.

The volt-time characteristics of the bushings on a transformer differ from the volt-time characteristics of the transformer internal insulation. In general, the bushing will have a higher flashover at short time lags than the transformer internal insulation. At long time lags its flashover may be slightly more or slightly less than the winding breakdown. The impulse strength of the winding is essentially the same for positive or negative waves; whereas the bushing critical flashover may be higher for one polarity than for the other. The manufacturer takes the overall impulse characteristics of a transformer into account when

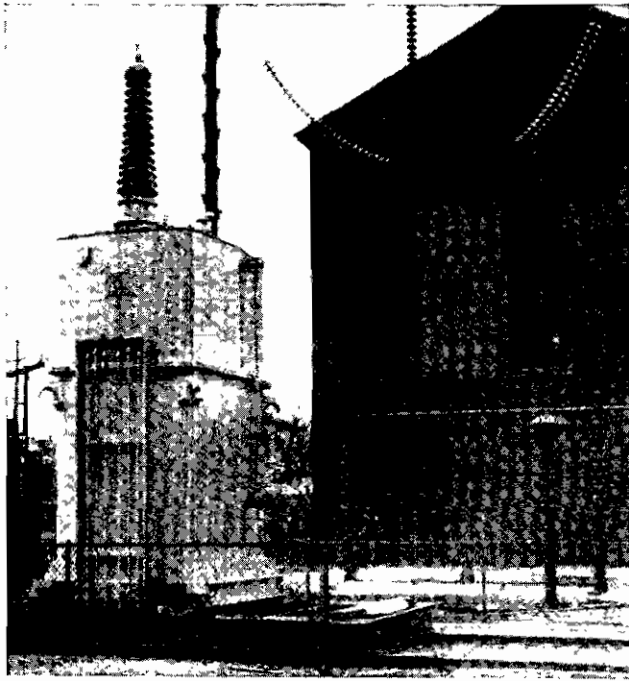

Fig. 22—Power transformer undergoing impulse test. Surge generator is in building in background.

giving its withstand voltage characteristic. A transformer undergoing an impulse test is illustrated in Fig. 22.

7. Impulse Characteristics of Other Station Apparatus

In addition to power transformers, the outdoor station generally has instrument transformers, circuit breakers, disconnect switches, and bus insulators exposed to lightning surges. Some stations will also include reactors and regulating equipment. All of this equipment now meets the basic impulse insulation levels listed in Table 1.

The standard withstand impulse tests for instrument transformers, regulators, and reactors are shown in Table 4, referred to above for transformers. The withstand impulse tests for outdoor circuit breakers, disconnect switches, and bus insulators are the same as those listed in Table 5 for outdoor bushings.

IV. CHARACTERISTICS OF PROTECTIVE DEVICES

The purpose of a protective device is to limit the surge voltage that may be applied to the apparatus it protects and by-pass the surge to ground. It must withstand continuously the rated power voltage for which it is designed. The ratio of the maximum surge voltage it will permit on discharge to the maximum crest power voltage it will withstand following discharge, called the protective ratio, is, therefore, a measure of its protective ability. Of great importance also is its ability to discharge severe surge currents, either of high magnitude or long duration, without injury.

There are three general types of lightning-protective devices, each having its field of application; namely, the

rod gap, the protector tube, and the conventional valve-type lightning arrester.

Rod Gap—Although the rod gap has the advantage of being extremely simple and rugged, it has two important disadvantages from a protective standpoint. First, it does not fulfill one of the requirements of a true protective device in that it will not valve off power voltage after it has once been flashed over by a surge. The circuit must be deenergized to clear the flashover each time the gap operates. Second, its breakdown voltage rises more at short time lags than most insulation, which means that a relatively short gap is required to provide protection against surges having steep wave fronts. It would thus have a low flashover at long time lags that would result in numerous flashovers with consequent outages resulting from minor lightning surges or severe switching surges. The rod gap is, therefore, generally used only for back-up protection or on circuits where the outages with short gaps can be tolerated or compensated for by high-speed reclosing of the circuit energizing breaker.

Modifications of the rod gap, such as the fused gap and control gap, have been used occasionally. The fuse gap is simply a rod gap with a fuse in series with it to interrupt the power follow current caused by the flashover. It, therefore, has the same surge protective characteristic

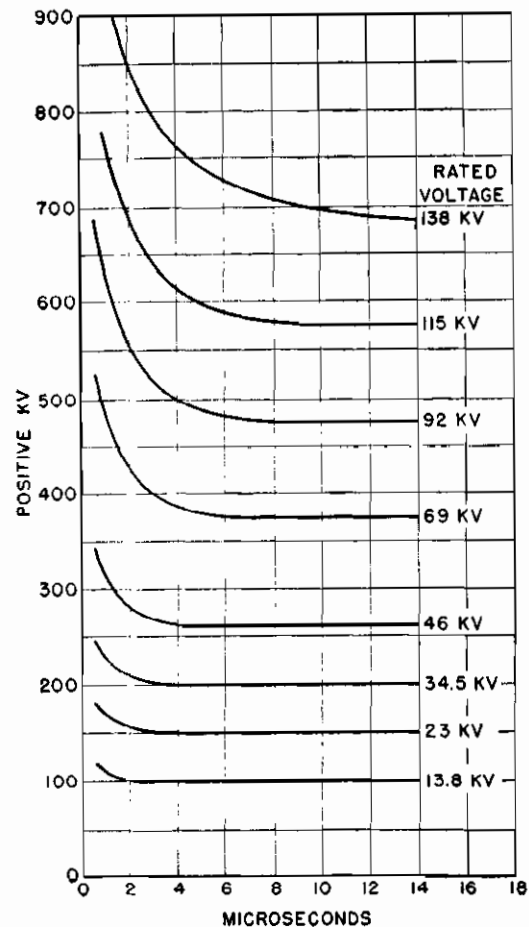

Fig. 23—Impulse characteristics of transmission type protector tubes for grounded-neutral circuits.

TABLE 6—INDUSTRY PERFORMANCE CHARACTERISTICS OF DISTRIBUTION EXPULSION-TYPE LIGHTNING ARRESTERS

Rated Voltage of Arrester Kv	Front of Wave Impulse Sparkover				Average Critical Impulse Sparkover 1.5×40 Microsec. Wave Kv**
	Rate of Rise* Kv per Microsec.	Kv**			
		Min	Avg	Max	
3	25	23	33	45	29
6	50	32	50	70	41
9	75	48	71	97	53
12	100	63	84	94	61
15	125	77	101	114	70

*100 kv per microsecond per 12 kv of arrester rating.
 **Impulse of polarity giving higher sparkover voltage.

as the plain rod gap and, although it prevents a circuit outage upon flashover, it requires the replacement and maintenance of fuses. Also, to be effective it requires proper coordination between the fuse blowing time and adjacent relay timing.

The control gap⁹, consisting of a double gap arrangement to approach a sphere gap characteristic, has a somewhat better volt-time characteristic than the rod gap. It can be used with or without fuses, and although it is applicable for back-up or secondary protection, it is usually considered in the same class as the rod gaps, as far as major protection is concerned.

Protector Tube—The transmission type protector tube has a volt-time characteristic, Fig. 23, somewhat better than the rod gap and has the ability to interrupt power voltage after flashover. It is, therefore, used extensively to prevent flashover of transmission line insulators, dis-

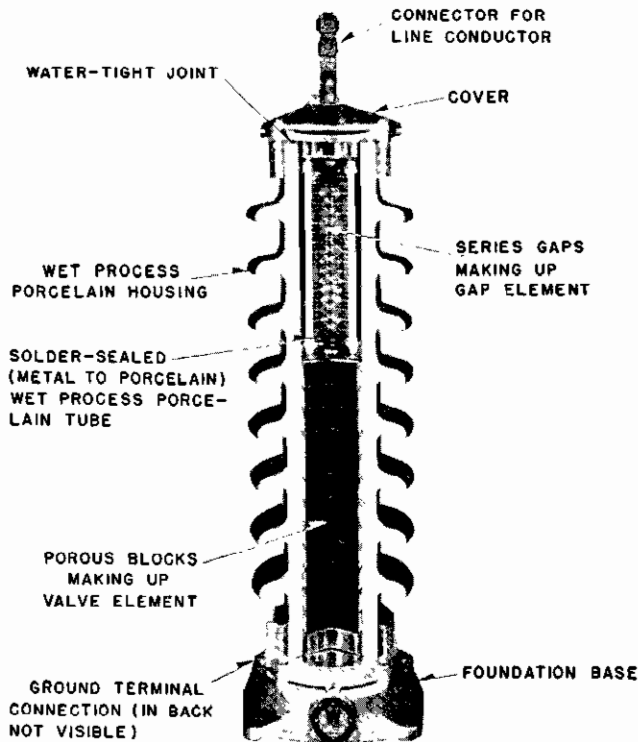
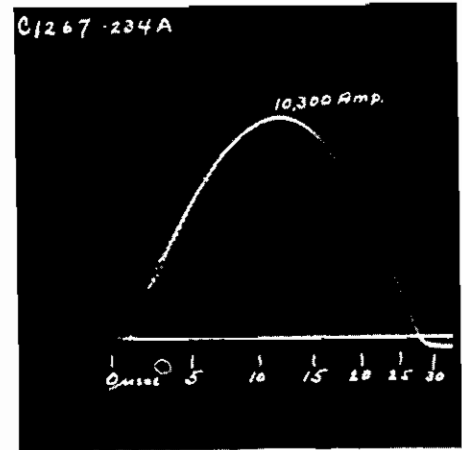
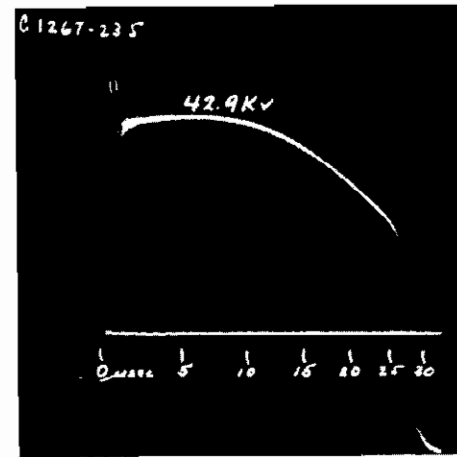

Fig. 24—Sectional view of station-type lightning arrester.



(a)



(b)

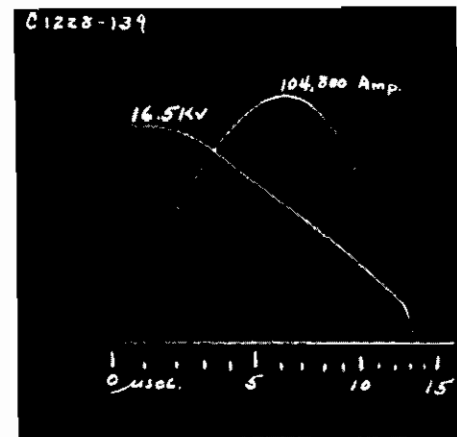

(c)

Fig. 25—Typical oscillograms of current discharge tests in lightning arresters.

- (a) Standard 10×20 microsecond current surge applied to 12 kv station type arrester.
- (b) Arrester voltage during discharge of current surge shown in (a).
- (c) Current and voltage of 3 kv station type arrester discharging a 5×10 microsecond current surge having a crest in excess of 100 000 amperes.

TABLE 7—PERFORMANCE CHARACTERISTICS OF VALVE-TYPE LIGHTNING ARRESTERS

Arrester Type and Rated Voltage—Kv	Front of Wave Impulse Sparkover				Discharge Voltage-Kv on 10 x 20 Microsecond Current Wave**								
	Rate of Rise* Kv per μ sec.	Kv**			5,000 Amperes			10,000 Amperes			20,000 Amperes		
		Avg.	Max.	†	Avg.	Max.	†	Avg.	Max.	†	Avg.	Max.	†
<i>Distribution</i>													
3	25	18	23	23	14	17	17	16	20	20	18	23	23
6	50	34	45	45	26	34	34	30	38	38	34	44	44
9	75	48	62	62	39	51	51	44	57	57	51	66	66
12	100	61	77	77	49	62	62	55	69	69	62	78	78
15	125	73	91	91	61	77	77	69	87	87	79	99	99
<i>Line</i>													
20	167	75	90	85	83	96	91	92	106	102	101	116	111
25	208	93	111	105	101	116	111	111	128	122	121	139	133
30	250	110	132	125	121	139	133	135	155	149	149	172	164
37	308	136	163	154	149	172	164	164	189	181	181	208	199
40	333	147	176	167	161	185	177	177	204	195	196	225	216
50	417	183	220	208	202	232	225	222	255	245	243	280	268
60	500	220	264	250	242	278	267	271	312	300	298	344	328
73	608	267	320	302	297	342	328	328	378	361	360	414	396
<i>Station</i>													
3	25	13	15	15	10	11	11	11	13	12	12	14	13
6	50	23	26	26	20	22	22	22	25	23	24	27	26
9	75	35	39	39	30	33	32	33	37	35	35	39	38
12	100	43	50	48	40	44	43	44	48	47	47	52	51
15	125	53	61	59	50	55	54	54	60	58	59	65	63
20	167	72	83	80	67	74	72	72	80	77	78	86	84
25	208	89	102	98	83	92	89	90	99	96	100	110	107
30	250	106	122	117	100	110	107	108	119	115	118	130	126
37	308	131	151	144	124	137	133	132	146	141	145	160	155
40	333	136	157	150	134	148	143	144	159	154	153	169	164
50	417	178	205	196	167	184	179	179	197	191	191	211	205
60	500	214	246	236	200	220	214	217	239	231	234	258	250
73	608	261	300	288	245	270	262	262	288	279	283	313	303
97	808	345	397	380	323	356	345	349	384	372	377	415	403
109	908	388	446	427	363	400	388	394	434	420	424	467	453
121	1008	430	495	474	403	444	430	438	482	467	470	517	502
145	1208	515	592	566	487	536	520	523	575	558	564	622	602
169	1408	602	693	663	566	624	605	610	672	650	658	725	702
196	1633	691	796	760	647	713	691	698	768	744	755	832	803
242	2017	860	988	945	806	887	860	872	960	931	940	1035	1004

*100 kv per microsecond per 12 kv of arrester rating.
 **Impulse of polarity giving higher sparkover voltage.

†95% of the arresters manufactured will have characteristics not exceeding the value in this column. For distribution arresters use the maximum values.

connect switches, and bus insulators. It is also used on transmission-line towers adjacent to a station to reduce the magnitude of surges coming in on the line and thus relieve the duty on the station arresters. The tube is not at the present time considered adequate protection for transformer insulation, except for distribution type ratings 15 kv and below. Its application on circuits above 15 kv requires certain limitations in system short-circuit currents and recovery voltage rates.

The protector-tube principle is used extensively for expulsion type arresters in the distribution classifications

15 kv and below. Industry performance characteristics of distribution expulsion-type lightning arresters are given in Table 6.

Valve-Type Arresters—The conventional valve-type lightning arrester, a typical example of which is shown in Fig. 24, provides the highest degree of protection of all protective devices. Its essentially flat volt-time characteristic makes it ideally suited for the protection of transformer insulation in the higher voltage classes where the margin between operating voltage and surge strength is relatively low. If properly applied, its discharge voltage

TABLE 8—INSULATION TESTS FOR LIGHTNING ARRESTERS
(Withstand Test Voltages)

Insulation Classification Kv	Arrester Voltage Rating Kv (1)	Station-type Arresters— All ratings Line and Distribution-type Arresters rated 20 Kv and above			Line and Distribution-type Arresters rated below 20 Kv			
		60-Cycle Test Voltage Rms Kv (2)		Impulse Test $1.5 \times 40 \mu\text{s}$ Full Wave Crest Kv (2, 3)	60-Cycle Test Voltage Rms Kv (2)		Impulse Test $1.5 \times 40 \mu\text{s}$ Full Wave Crest Kv (2, 3)	
		1 Min Dry	10 Sec Wet		1 Min Dry	10 Sec Wet		
		2.5	3	21	20	60	15	13
5	6	27	24	75	21	20	60	
8.7	9	35	30	95	27	24	75	
15	15	50	45	110	35	30	95	
23	25	70	60	150	
34.5	37	95	80	200	
46	50	120	100	250	
69	73	175	145	350	
92	97	225	190	450	
115	121	280	230	550	
138	145	335	275	650	
161	169	385	315	750	
196	196	465	385	900	
230	242	545	445	1050	

- (1) Where application is to be made of an arrester having a lower voltage rating than the rated voltage of the circuit on which it is to be used such as on grounded neutral circuits, the insulation test shall be that specified for the insulation class one step lower than the rated circuit voltage.
 (2) All values are withstand test voltages without negative tolerance.
 (3) Either positive or negative polarity waves may be used—whichever gives the lower value.

remains below the breakdown strength of the transformer insulation, even at short time lags. Experience with actual lightning discharges and laboratory tests have demonstrated the ability of the modern lightning arrester to discharge surges commensurate with direct strokes of lightning.

Lightning arresters for a-c power circuits are rated according to the maximum line-to-ground circuit voltage they will withstand. There are three classes available; namely, the station type with voltage ratings ranging from 3 to 242 kv, the line type, for 20 to 73 kv, and distribution type, 3 to 15 kv. The characteristics of these arresters are given in Table 7.

Station-type arresters, as distinguished by their heavier construction, better protective characteristics, and higher discharge-current capacity are used for the protection of substation and power transformers. Line-type arresters are used for the protection of distribution transformers, small power transformers, and sometimes small substations. Distribution type arresters are intended primarily for pole mounting in distribution circuits for the protection of distribution transformers up to and including the 15.0-kv classification.

Modern station-type arresters are designed to discharge not less than 100 000 amperes; line and distribution types not less than 65 000 amperes, each with a 5×10 micro-

second test wave. In addition, they are given an insulation test in accordance with Table 8, which is from ASA C 62 Standard dated April 1944.

The valve-type lightning arrester is usually made up of two elements, a gap element capable of withstanding power voltage and a valve element capable of suppressing the current following the discharge of the surge. The breakdown of the gap, which is affected somewhat by the rate of voltage rise, determines the initial discharge voltage of the arrester. The voltage drop across the valve element, which depends upon the rate of rise and magnitude of surge current discharged determines the arrester voltage during discharge.

Typical oscillograms of arrester current discharge tests are shown in Fig. 25.

The protective ratio of a modern lightning arrester is substantially constant through its range of voltage ratings which means that the gap break-down voltage and the maximum surge discharge voltage for a given surge condition are approximately proportional to the voltage rating of the arrester. The curves of Fig. 26 show how the gap breakdown varies with rate of voltage rise, and the curves of Fig. 27 show how the discharge voltage varies with the magnitude and rate of rise of surge current for typical line type and station type arresters. From these curves, expressing the gap breakdown and discharge voltage, each in terms of kv per kv of arrester rating, it is possible to determine readily the protective characteristics of any rating arrester for an expected surge condition.

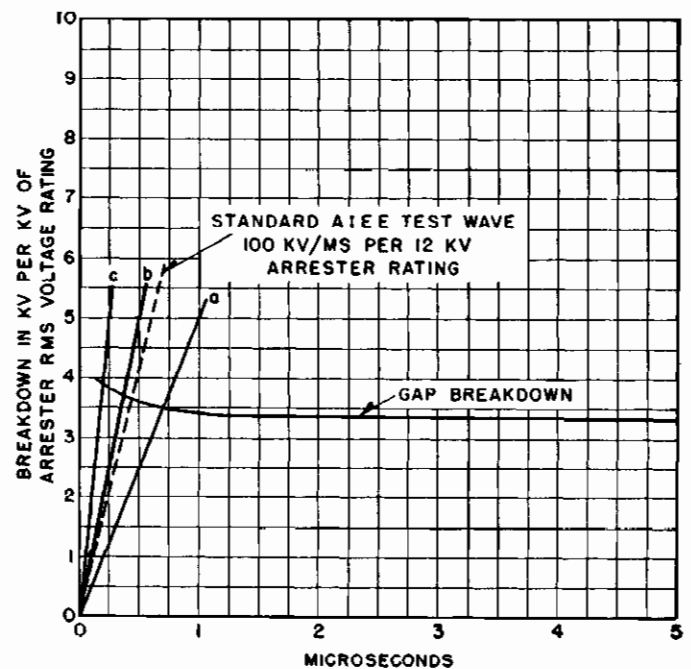

Fig. 26—Average impulse gap breakdown of station- and line-type arresters.

- (a) Represents rate of rise of 5 kv per microsecond per kv of arrester rating.
 (b) Represents rate of rise of 10 kv per microsecond per kv of arrester rating.
 (c) Represents rate of rise of 20 kv per microsecond per kv of arrester rating.

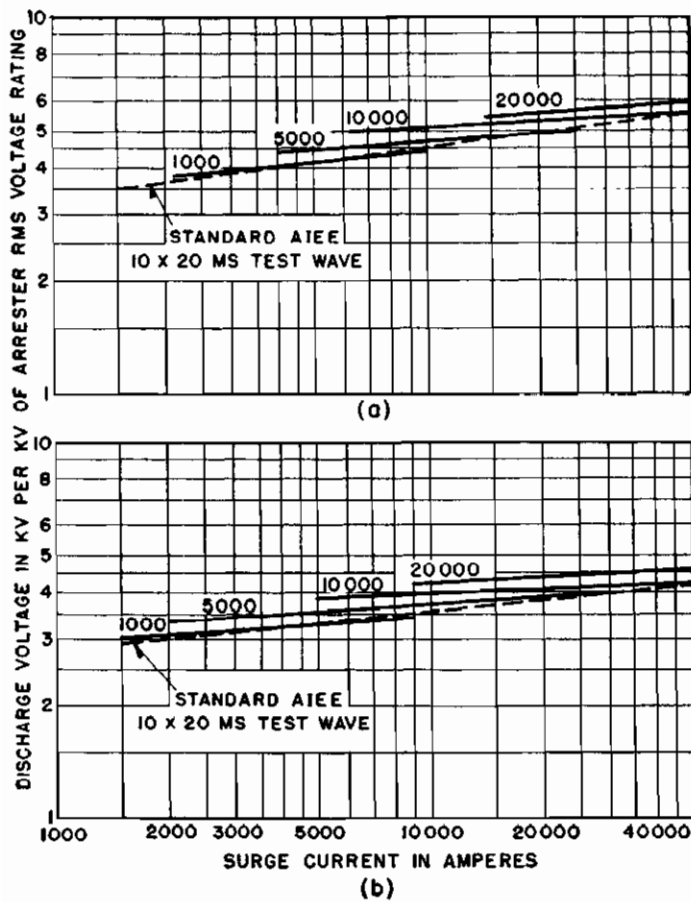

Fig. 27—Average discharge voltage characteristics of typical lightning arresters. (Numbers on curves represent rate of rise of current in amperes per microsecond.)

(a) Line type. (b) Station type.

For example, suppose it is desired to determine the gap breakdown voltage and maximum discharge voltage of a 73 kv, station-type arrester for a surge wave front rising at a rate of 500 kv per microsecond, and a discharge current of 2000 amperes with a maximum rate of rise of 2500 amperes per microsecond. A voltage rise of 500 kv per microsecond with a 73 kv arrester, represents a voltage rise of $\frac{500}{73} = 6.85$ kv per microsecond per kv of arrester rating.

From Fig. 26, the gap breakdown voltage would be $3.6 \times 73 = 263$ kv, at 0.5 microseconds. The maximum discharge voltage from Fig. 27 (b) would be $3.2 \times 73 = 234$ kv.

V. APPLICATION OF PROTECTIVE DEVICES

8. Selection of Arrester Rating

A valve type lightning arrester begins to discharge at a definite value of overvoltage in accordance with the curve of Fig. 26, and valves off at a lower voltage, corresponding to the maximum permissible voltage rating of the arrester. If the power voltage is above the valve-off voltage, the arrester may continue to discharge power current until it is destroyed.

Although modern lightning arresters will discharge with-

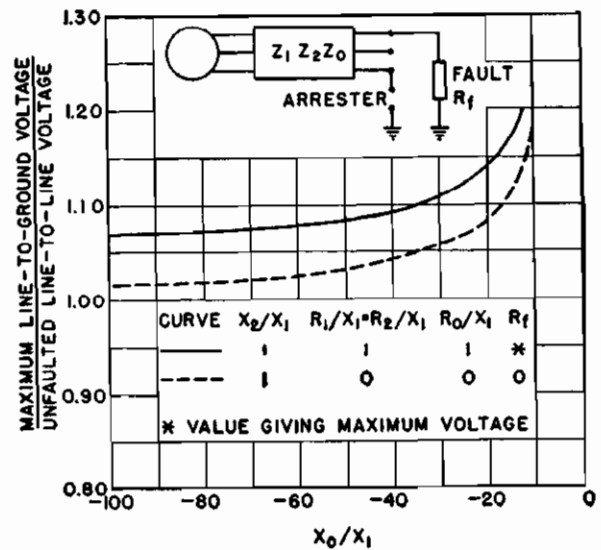

Fig. 28—Maximum line-to-ground voltage at fault location for isolated-neutral systems during fault.

Values shown are maximum values for single line-to-ground fault. For double line-to-ground fault the voltages are less for ratios of X_0/X_1 between $-\infty$ and -2 .

X_0 = zero-sequence capacitive reactance and X_1 = positive-sequence subtransient reactance.

out injury any lightning surge except the most severe direct strokes originating close to the arrester, it is not practical or economical to design them to discharge power current for any appreciable time. A lightning discharge may reach thousands of amperes, but the time is short, being measured in microseconds, so that the energy that is absorbed by the arrester is small compared to the energy that would have to be absorbed with a few amperes power flow for even a few cycles. The first consideration in applying an arrester should, therefore, be the maximum line-to-ground dynamic voltage to which the arrester may be subjected for any condition of system operation or fault.

High operating voltage may exist on the far end of long, high voltage, unloaded transmission lines because of charging current flowing through the line reactance. It can also be caused by the sudden loss of load on water-wheel generators. It is sometimes possible to rearrange the switching scheme to eliminate or at least minimize the possibility of overvoltages from these sources. These factors, however, must be taken into account in the application of lightning arresters.

The maximum rms line-to-ground voltage during a system fault can be calculated by the methods of Chap 14, taking into account the constants of the system, the type of fault, and the fault resistance. The selection of the arrester rating should, where possible, be based on such calculation. Where the fault voltages are not determined more accurately by calculation, Fig. 28¹² and Fig. 29¹², can be used as guides in selecting the arrester rating.

The curves of Fig. 28 show the maximum line-to-ground voltage during fault for isolated-neutral systems as a function of the ratio of zero-sequence capacitive reactance, X_0 , to positive-sequence inductive reactance, X_1 . In Fig. 29, applying to grounded neutral systems, the ratio of

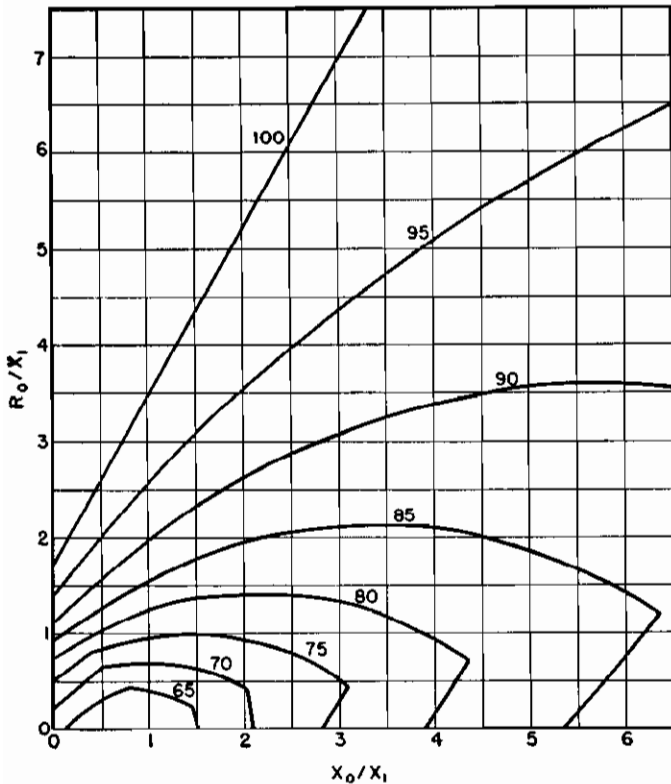

(a) Voltage conditions neglecting positive- and negative-sequence resistance— $R_1=R_2=0$.

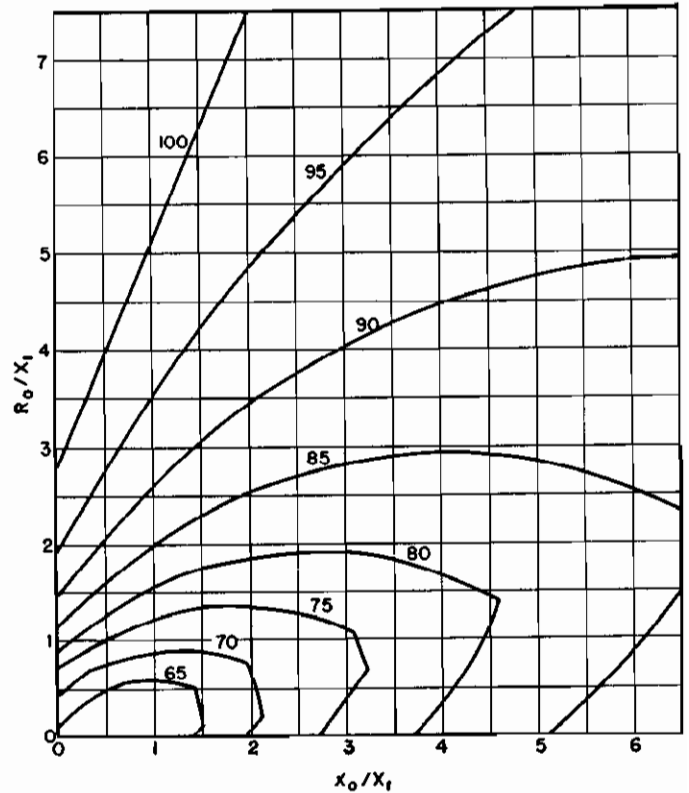

(c) Voltage conditions for $R_1=R_2=0.2 X_1$.

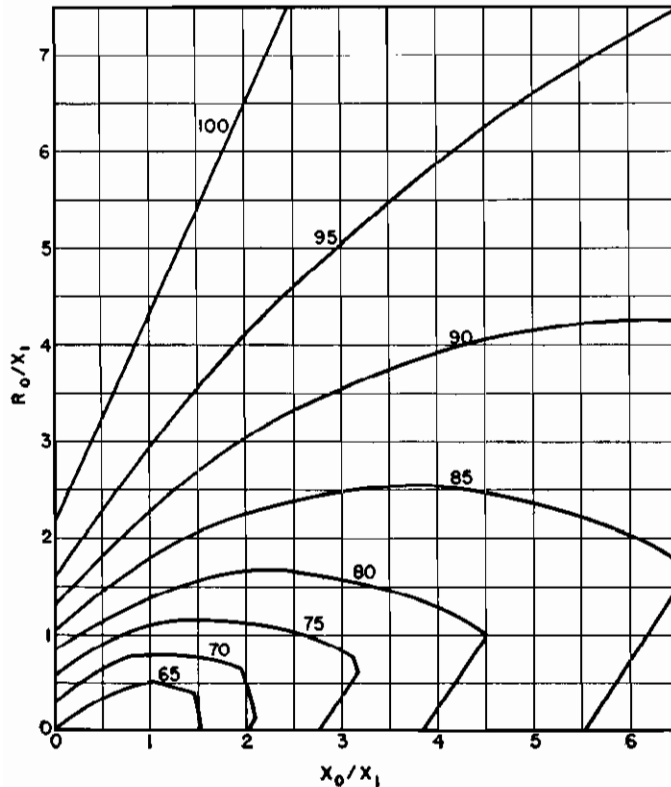

(b) Voltage conditions for $R_1=R_2=0.1 X_1$.

Fig. 29—Maximum line-to-ground voltage at fault location for grounded-neutral system under any fault condition.

Note: Numbers on curves indicate maximum line-to-ground fault voltage of any phase for any type of fault in percent of unfaulted line-to-line voltage for area bounded by curve and axes. When using the curves all impedance values must be on the same kva base or in ohms on same voltage base. For all curves

- R_0 = zero-sequence resistance,
- X_0 = zero-sequence inductive reactance,
- X_1 = positive-sequence subtransient reactance,
- X_2 = negative-sequence reactance,
- $X_1 = X_2$.

The effect of fault resistance was taken into account. The fault resistance which gives the maximum voltage to ground on any phase was the value used. The discontinuity of the curves is caused mainly by the effect of fault resistance.

zero-sequence resistance, R_0 to X_1 , is plotted against X_0/X_1 , for several different values of maximum line-to-ground fault voltages, ranging from 65 to 100 percent of line voltage and for three values of R_1/X_1 , namely 0, 0.1 and 0.2. The area below each curve represents the region in which the maximum fault voltage is below the value indicated on the curve. The curves represent the maximum voltage at the fault location. A fault at the arrester will generally subject the arrester to a higher voltage than a fault at some other point in the system. However, this condition does not always exist, and should be checked. For example a fault near the source of a radial feeder circuit grounded at the source only through a neutral resistor or reactor might have a larger value of $\frac{R_0}{X_1}$, or $\frac{X_0}{X_1}$,

and therefore produce a higher voltage on an arrester located at the end of the feeder than a fault at the arrester location.

In applying arresters, it is customary to make an allowance for operation at a voltage in excess of that usually considered as normal. This is usually five percent. For example, an arrester rated at 105 percent of normal line-to-line voltage is used where the line-to-ground voltage is expected to reach normal line-to-line voltage during fault. Likewise, on a solidly grounded neutral system where the maximum line-to-ground voltage during fault is expected not to exceed 80 percent of line voltage, an arrester rated at about 84 percent of normal line-to-line voltage has been used generally. The line-to-ground voltage for fault conditions where X_0/X_1 ratio is near 1.0 or less may allow the use of arresters with less than 84 percent of line-to-line voltage.

There are a number of isolated-neutral systems on which arresters rated at 105 percent of nominal line-to-line voltage have proven satisfactory over a period of years. However, there are also systems of this type where it has been necessary to use arresters of a higher rating to prevent excessive failures. This is indicated in Fig. 28, which shows that if fault resistance is included, the fault voltage may exceed 105 percent of normal line-to-line voltage. Calculation should be made to determine the maximum fault voltages.

The overvoltages encountered on systems grounded through ground-fault neutralizers are less than on isolated neutral systems, provided the ground-fault neutralizer is properly tuned. Arresters rated to withstand maximum line voltage, usually 105 percent of normal circuit voltage, are, therefore, considered safe for application on these systems. There is some risk of damage to the arrester if the ground-fault neutralizer is not properly tuned. Switching operations on these systems may also produce high voltages to ground. However, it is generally not feasible to select arresters of sufficiently high rating to eliminate all risk of arrester damage from these causes.

It has been common practice to apply arresters rated at 105 percent of circuit voltage to systems grounded through impedance, and arresters rated at 84 percent of circuit voltage (80 percent of 105 percent rating) to systems considered solidly grounded. Experience has shown that such applications are generally safe against over-voltage at time of fault. However, as indicated by Fig. 29, the possible line-to-ground voltages during faults on systems vary through a wide range, depending upon the ratio of system constants. Arresters rated at some voltage between 75 and 105 percent of circuit voltage may, therefore, be better suited from an overall standpoint.

As indicated by Fig. 29 (a, b, c), the maximum voltage to ground varies with the ratios of R_0/X_1 , X_0/X_1 and R_1/X_1 . Thus the voltage to ground can be determined for a given system if the impedance constants are accurately known. In some cases, particularly for the higher voltage systems, where the X_0/X_1 and R_0/X_1 ratios are 1.0 or less, arresters less than 84 percent of line-to-line voltage can be used, thus allowing the application of transformer insulation with a minimum acceptable impulse insulation level.

The 84-percent arrester can be applied safely on systems whose constants are within the range indicated by the 80-percent curve of Fig. 29 provided the impulse insulation level of the equipment is protected. As a general guide to arrester application, with full insulation on the protected equipment, the 84 percent arrester rating is satisfactory if the following conditions exist.

1. The ratio of the zero-sequence resistance, R_0 , to the positive-sequence subtransient reactance, X_1 , as viewed from the point of arrester location is one or less.
2. The ratio of zero-sequence reactance, X_0 , to positive-sequence reactance, X_1 , as viewed from the point of arrester location does not exceed three under any condition of operation.
3. The arrester cannot remain energized from ungrounded sources of power after the grounded neutral sources of power have been disconnected to clear a fault.
4. The system neutral is grounded at every source of supply of short-circuit current.

If the fault is to the arrester ground, then the resistance of the arrester ground should be included as part of the zero-sequence resistance of the system. When this is done, the curves of Fig. 29 also apply to the arrester at that fault location.

In addition to high arrester voltages resulting from system faults, high momentary or peak voltages may also be caused by any of the following:

1. Switching surges may reach several times normal line-to-ground voltage with certain combinations of system constants.
2. High harmonic voltages to ground may exist during fault conditions on lightly loaded lines energized from generators with damper windings for which X_q''/X_d'' is too great. See Chap. 6.
3. Arcing grounds or the accumulation of static charges from dust particles in the air on ungrounded systems may cause repetitive discharges through the arrester that exceed its thermal capacity.

It is not considered feasible to apply arresters rated sufficiently high to withstand the overvoltages that might be produced by any of the above. However, the possibility of damage to the arrester from these causes should be considered in making the application. It is sometimes possible to make minor modifications to the system equipment or operation that will greatly alleviate these sources of trouble.

Where there is doubt as to the arrester rating, the maximum line-to-ground voltages should be calculated by the methods of Chap. 14.

9. Coordination of Protective Devices with Apparatus Insulation

The margin that should exist between the BIL of the insulation to be protected and the maximum voltage that can appear across a lightning arrester is a much-discussed question. The answer is difficult because it depends on many factors. The *breakdown voltage* of the arrester is affected by the rate of voltage rise and the *discharge voltage* by the rate of rise of the surge current and the magnitude

of the surge current. The distance between the arrester location and the protected insulation affects the voltage imposed on insulation due to reflections. The severity of the surge depends upon how well the station is shielded, the insulation level of the station structure, and the incoming line insulation. A typical problem is reviewed later to give one way of applying a suitable margin.

Direct strokes to an arrester should be eliminated, where possible, by proper shielding because the current in a direct stroke may be in excess of that for which the arrester is designed. Where shielding is impractical, the arrester should protect the insulation within the range of direct-stroke surge currents within the capability of the arrester. Currents in excess of the arrester rating may damage or ruin the arrester.

For a traveling wave coming into a dead-end station, the discharge current in the arrester is determined by the maximum voltage that the line insulation can pass, by the surge impedance of the line, and the voltage characteristic of the arrester, according to the following relation:

$$I_a = \frac{2E - E_a}{Z}$$

where I_a —arrester current
 E —magnitude of incoming surge voltage
 E_a —arrester terminal voltage
 Z —surge impedance of the line

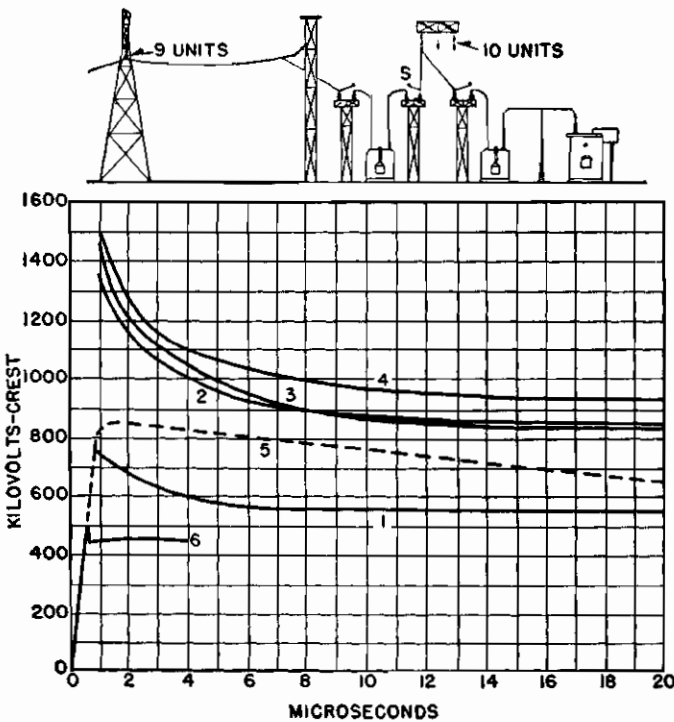

Fig. 30—Coordination of insulation in a 138-kv substation for 1 1/2 x 40 microsecond positive wave.

- (1) Transformer with 550 kv BIL.
- (2) Line insulation of 9 suspension units.
- (3) Disconnect switches on 4 apparatus insulators.
- (4) Bus insulation of 10 suspension units.
- (5) Maximum 1 1/2 x 40 wave permitted by line insulation.
- (6) Discharge of 121-kv arrester for maximum 1 1/2 x 40 full wave.

Suppose it is desired to protect the 138-kv substation shown schematically in Fig. 30 against traveling waves. The system at this point is grounded so as to allow a basic impulse insulation level of 550 kv. The major equipment consists of a power transformer, circuit breakers, disconnect switches mounted on four apparatus insulator units, and bus insulation consisting of 12 suspension insulators. The line insulation consists of nine suspension insulators. The arrester is located close to the transformer. Adequate shielding is provided over the substation and the incoming transmission lines.

The line insulation of nine insulators permits a traveling wave of 860-kv crest (1 1/2 x 40) and rate of rise of 1000 kv per microsecond to enter the station. This rate of rise represents 8.25 kv per microsecond per kv of arrester rating for the required 121-kv arrester. From Fig. 26 the average arrester-gap breakdown is 3.6 x 121 or 435 kv at 0.5 microsecond, which, with a 15 percent plus tolerance, becomes 500 kv. Assuming a line surge impedance of 400 ohms, the magnitude of the arrester current is about 3200 amperes determined as follows:

$$I_a = \frac{2(860\,000) - 435\,000}{400} = 3200 \text{ amperes.}$$

The rate of rise of current would be approximately

$$\frac{2(1\,000\,000)}{400} = 5000 \text{ amps/microsecond.}$$

From Fig. 27(b) the discharge voltage for a current of 3200 amperes and a rate of rise of 5000 amperes is 3.45 x 121 or 418 kv. Adding the manufacturing tolerance of plus 10 percent gives 460 kv as the discharge voltage provided by the 121-kv arrester for the assumed conditions. Since the rate of rise has been taken into consideration in establishing this protective level of 460 kv, no additional margin need be added. There is, however, a difference of 550 minus 460 or 90 kv between the protective level and the BIL of 550 kv of the transformer insulation.

Suppose a direct stroke at the station discharges through the arrester a current of 50 000 amperes, rising to crest in three microseconds, with a nominal rate of rise of 20 000 amperes per microsecond. The discharge voltage from Fig. 27 (b) is 4.55 x 121 = 550 kv for a 121-kv arrester which with plus 10 percent is 605 kv or 55 kv in excess of the insulation BIL.

10. Location and Connection of Protective Devices

The protective device should be placed as close as possible to the apparatus it is to protect, particularly if an overhead line dead ends in a station or terminates at a transformer. A traveling wave coming into the station is limited in magnitude at the arrester location to the discharge voltage of the arrester. However, a wave with the same rate of voltage rise as the original wave and with a magnitude equal to the arrester discharge voltage travels on to the station terminus where it reflects to twice its value if the line dead ends or to almost twice its value if the line terminates in a transformer. The voltage at the transformer builds up at a rate twice that of the original wave until it reaches a maximum value of twice

the magnitude of the arrester voltage or to whatever voltage magnitude can build up during the time the reflected wave travels back to the lightning arrester and a negative reflected wave travels from the lightning arrester back to the transformer.

Likewise, apparatus, such as a disconnect switch, located ahead of the arrester is subject to the incoming surge until the arrester discharges and its negative reflected wave returns to the switch.

To illustrate the effect of arrester location consider the 138-kv station shown schematically in Fig. 31 with the arrester located 100 circuit feet beyond the disconnect switch and 100 circuit feet ahead of the transformer. Consider a traveling wave having a rate of voltage rise of 1000 kv per microsecond entering the station and an arrester which limits the voltage to 400 kv. In 0.1 microsecond after the wave reaches the switch it reaches the lightning arrester and 0.1 microsecond later, or at the end of 0.2 microsecond, it reaches the transformer where it reflects and builds up at a rate of 2000 kv per microsecond. At the end of 0.4 microsecond after the wave first reached the switch, the incoming wave and the reflected wave from the transformer would total to 400 kv at the arrester. As shown in Fig. 31, the voltages at the switch and at the transformer would also be 400 kv. The reflected wave from the transformer has just reached the switch. The voltage at the arrester remains at 400 kv until the crest of the incoming wave is reached but the voltages at the switch and transformer continue to rise at 2000 kv per microsecond until the reflected negative waves from the arrester reaches the switch and transformer at the end of 0.5 microsecond. Successive reflections occur until the wave spends itself by discharging through the arrester. As shown in Fig. 31, the voltages at the switch and transformer resulting from the first reflection reaches 600 kv, or 50 percent more than the arrester discharge voltage.

The maximum voltage at the terminus of a line or at a transformer at the end of a line beyond an arrester as a

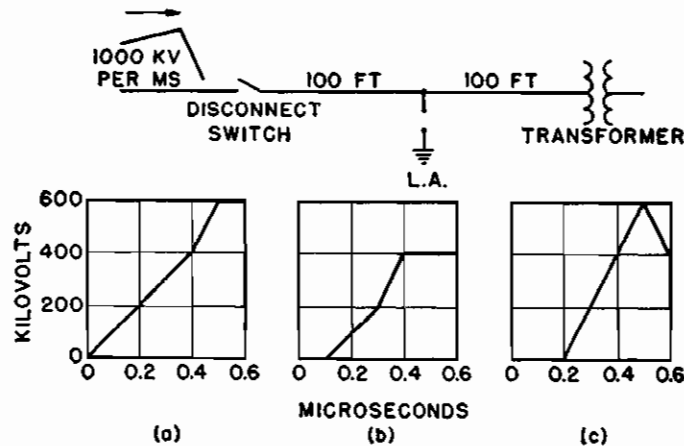

Fig. 31—Voltages at 138 kv substation resulting from first reflection of traveling surge having 1000 kv per microsecond wave front.

- (a) At disconnect switch located 100 feet ahead of arrester.
- (b) At arrester.
- (c) At transformer located 100 feet beyond arrester.

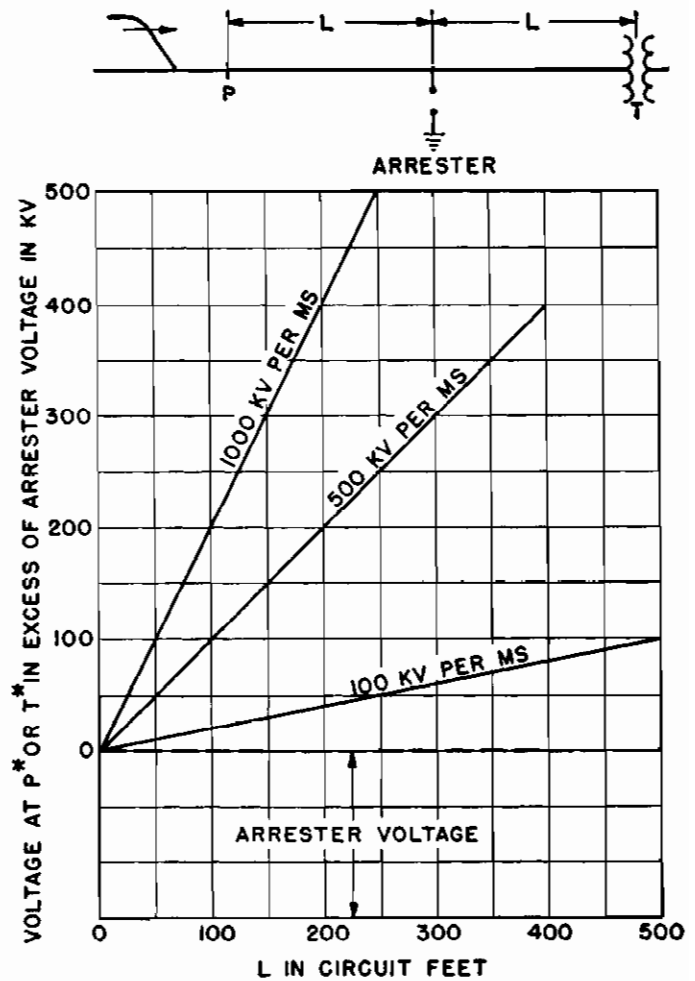

Fig. 32—Maximum voltage due to first reflection of traveling wave as function of distance from arrester and steepness of wave front.

*Voltage at P may reach crest of incoming surge as maximum. Voltage at T may reach twice arrester voltage as maximum.

result of the first reflection of a traveling wave, may be expressed mathematically, as follows¹³:

$$E_t = e_a + 2 \frac{de}{dt} \times \frac{L}{1000}$$

up to a maximum of $2 e_a$,

where e_a = arrester discharge voltage

$\frac{de}{dt}$ = rate of rise of wave front in kv per ms.

L = distance between arrester and line terminus in feet.

The same expression can also be used to determine the voltage at a point on a line ahead of an arrester due to a traveling wave. In this case, the voltage can reach as a maximum the crest of the traveling wave if the distance to the arrester is great enough or if the rate of rise of the wave front is sufficiently high.

The curves of Fig. 32 show the voltage in excess of the arrester voltage as a function of distance from the arrester for rates of rise of wave front of 100, 500, and 1000 kv per

microsecond. The curves can be used to determine the actual voltage at a point ahead of an arrester or at a line terminus beyond an arrester by adding to the curve value the discharge voltage of the particular arrester involved. For example, the maximum voltages obtained at the switch and transformer in Fig. 31, by plotting the volt-time curves, could be taken from the 1000 kv per microsecond curve of Fig. 32. For a distance of 100 feet, and a wave front that rises at the rate of 1000 kv per microsecond, the voltage in excess of the arrester voltage is 200 kv. This added to the arrester discharge voltage, assumed to be 400 kv, gives 600 kv as the maximum voltage after the first reflection.

In addition to the reflected wave phenomena, it is quite possible that still higher peak voltages would exist at the apparatus as a result of oscillations caused by the induct-

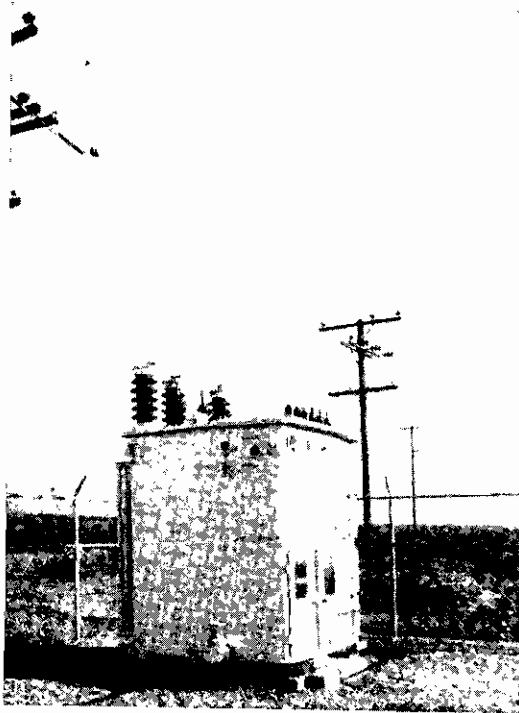

Fig. 33—Installation view of CSP power transformer with protective devices, secondary circuit breaker, and metering equipment built integral with transformer.

ance of the line between the arrester and the apparatus, and the capacitance of the apparatus. Furthermore, the voltage drops in the lead from the line to the arrester and in the lead from the arrester to ground, which are affected by rate of rise of surge current, add to the drop across the arrester. Any difference in ground potential between the apparatus ground and the arrester ground also adds to the voltage impressed across the apparatus insulation. In view of the above factors, it is important, particularly in stations where direct strokes may originate close to the station, that the protective devices be located close to the apparatus they are to protect, that the leads to the devices be kept as short and direct as possible, and that the arrester and apparatus grounds be interconnected and as low in resistance as possible, preferably one ohm or less.

The ultimate in this respect is reached when the protec-

tive device is mounted directly on the transformer. This is illustrated in the installation view, Fig. 33, of a CSP transformer which has the protective devices, secondary circuit breaker, and metering equipment built integral with the transformer¹⁴. With the line side of the arresters connected directly to the transformer terminals and the arrester ground connected directly to the transformer tank, the voltage between the winding and core is definitely limited to the discharge voltage of the arrester. To provide protection to an extended station an arrester should be located directly ahead of the disconnect switch where the line enters the station and another arrester located directly adjacent to or on the transformer. A modification of this scheme, which is sometimes used, is to locate protector tubes at the entrance to the station and conventional station type arresters at the transformer terminals. The protector tubes will generally protect the switch and will limit the magnitude of surges entering the station.

11. Direct Stroke Protection

Wherever it is possible for direct strokes of lightning to strike the line at or near the station, there is a possibility of exceedingly high rates of surge-voltage rise and large magnitude of surge-current discharge. If the stroke is severe enough, the margin of protection provided by the protective device may be inadequate. The installation may, therefore, justify shielding the station and the incoming lines far enough out to limit the severity of surges that can come into the station, particularly in the higher voltage classifications, 69 kv and above. This can be done by properly placed masts or overhead ground wires.

The number of direct strokes per year to an unshielded substation, based on accumulated records of direct strokes to tall objects, can be approximated by the expression¹⁵

$$\frac{(W+700)(L+700)}{(5280)^2} 9.5$$

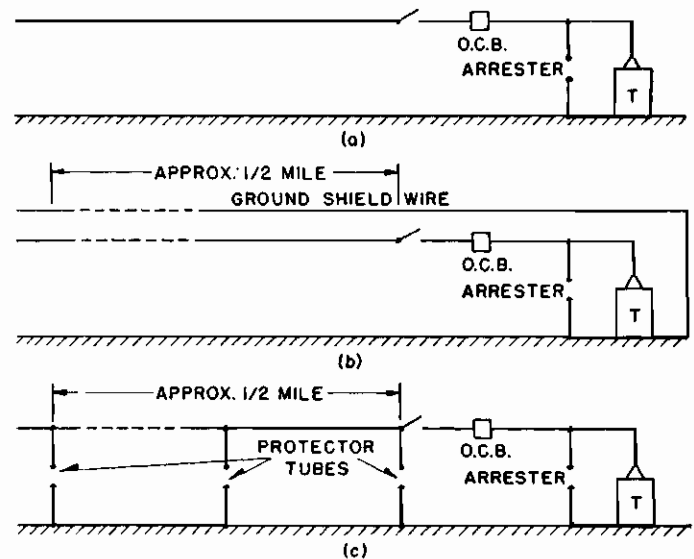

Fig. 34—Typical schemes of station protection.

- (a) Arrester at station with no direct stroke shielding.
- (b) Arrester at station with shielding against direct strokes.
- (c) Arrester at station with protector tubes extending out 1/2 mile.

where W and L are the width and length, respectively, in feet, of the substation. From this estimate of strokes to an exposed substation, which is about one stroke every four and one-half years to a 100 feet square substation, it can be reasoned that reducing the exposure to 0.1 percent would practically eliminate the possibility of a stroke to a station. The curves of Fig. 35¹⁵ were, therefore, constructed from extensive laboratory test data to show the configurations of masts or overhead ground wires necessary to reduce the exposure of an object to 0.1 percent. The curves are plotted to show the height (L) of the shielding

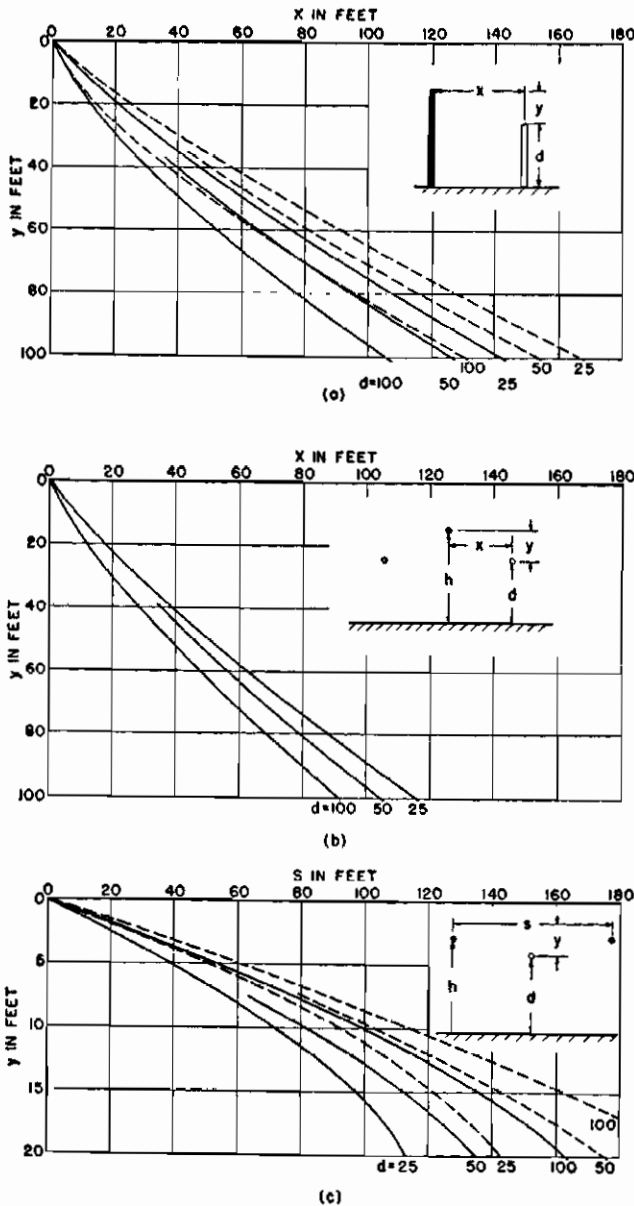

Fig. 35—Configuration of shielding object with respect to protected object for 0.1 percent exposure.

- (a) One shielding mast. Dotted lines for one exposed object of height (d). Full lines for ring of exposed objects of height (d).
- (b) One horizontal ground wire.
- (c) Two masts or two ground wires. Dotted lines for masts. Full lines for horizontal wires.

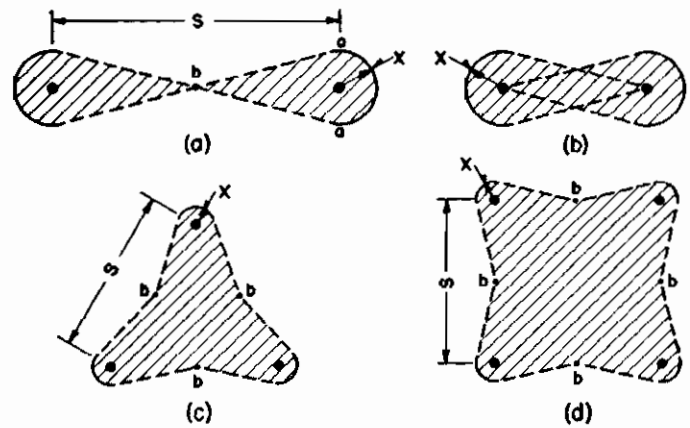

Fig. 36—Areas protected by multiple masts for point exposures of 0.1 percent.

- (a) Two masts with values of x and s taken from Fig. 35 (a) and (c).
- (b) Two masts separated by half the distance of those in (a).
- (c) Three masts with (b) points obtained from Fig. 35 (c) for mid-point between two masts.
- (d) Four masts with (b) points obtained from Fig. 35 (c) for mid-point between two masts.

masts or ground wires above the protected object as a function of the horizontal separation (X) and the height (d) of the protected object.

The dotted-line curves, Fig. 35 (a), showing the necessary configuration of a single mast protecting a single object, apply to an exposed structure having a single prominent projection or several projections in a limited region, such as a set of disconnects. The full-line curves, applying to a ring of objects, should be used if the live parts to be shielded are generally distributed at a given height. The configuration of the mast should be based on the most remote object.

The required configurations of a single horizontal ground wire are given in Fig. 35 (b). The dotted-line and the full-line curves of Fig. 35 (c) apply, respectively, to two masts and to two horizontal ground wires.

The diagrams of Fig. 36¹⁵ illustrate the area that can be protected by two or more shielding masts. The cross-hatched area of Fig. 36 (a) is the area protected by two masts for given values of d and y , where the radii x of the semi-circles are taken directly from Fig. 35 (a), and the separation distance S from Fig. 35 (c). If the distance between masts is decreased, the protected area is at least equal to the area obtained by superposing the areas of Fig. 36 (a). For example, if the distance between masts is halved, the resultant protected area is somewhat as shown in Fig. 36 (b).

On this basis, to form an approximate idea of the width of the overlap between masts, first obtain a value of y from Fig. 35 (c), corresponding to twice the actual distance between the masts. The width of overlap is then equal to the value of x , obtained from Fig. 35 (a), that correspond to this y . This undoubtedly gives a conservative width of substation that can be protected by two masts.

For three masts located at the points of an equilateral triangle or for four masts located at the points of a square,

the protected areas are as shown in Figs. 36 (c) and (d). The height of the shielding mast should be so chosen that the b points provide 0.1 percent exposure as obtained from Fig. 35 (c) for the midpoint between two masts. The x radii are obtained from the data for a single mast.

The curves of Fig. 35 apply to stations located in regions of relatively flat terrain and low resistivity, where the effective ground plane is essentially at the earth's surface. High values of earth resistivity lowers the ground plane, which results in less effective shielding for a given configuration. However, most stations are, or if not, should be, provided with low-resistance grounding systems for lightning-arrester grounds, which can also serve as shielding grounds. Where the soil resistivity is high the effective ground plane can be raised to the earth's surface by laying counterpoise wires from the shielding masts to distances of two or three times their height. However, in most cases, it is probably more economical to increase the height of the masts.

For application of the curves to hillside locations, the dimensions (h) (the shielding mast height) and (d) (the height of the protected object) should be measured perpendicular to the earth's surface. The distance (x) between the object and shielding mast should be measured along the earth's surface.

The lines coming into the station can be effectively shielded against direct strokes by overhead ground wires as outlined in Chap. 17. A direct stroke on a line more than $\frac{1}{2}$ mile out from the station is limited in severity at the station by the surge impedance and insulation of the line and to some extent by the shunt capacity of the station equipment. Shielding of the station and the lines approximately $\frac{1}{2}$ mile out from the station, as illustrated in Fig. 34 (b), is, therefore, a desirable supplement to the lightning arrester located at the station.

Where overhead ground wires on the incoming lines are not practical due to existing construction, additional protection of the station equipment against direct strokes on the lines near the station can be obtained by equipping each line with protector tubes at the entrance structure of the station and at each tower for a distance of approximately $\frac{1}{2}$ mile out from the station, see Fig. 34 (c). However, shielding the station is the only way to eliminate direct strokes to the station itself.

12. Summary of Considerations Applying to Protection of High-Voltage Equipment

The following points can be generally concluded in the application of protective devices to high-voltage systems, 22 kv and above.

1. Rod-gaps do not protect apparatus insulation against surges of steep wave front unless the spacing is so low that the gap is subject to numerous flashovers from minor surges.
2. Protector tubes are not considered suitable for the protection of apparatus insulation although they are effective in preventing transmission-line flashovers and in decreasing the severity of surges from direct strokes near the station. The application of protector tubes involves certain limitations in system short-circuit and recovery voltage characteristics.

3. Modern type lightning arresters applied properly protect station apparatus conforming to basic insulation levels against traveling surges. On systems having a solidly grounded neutral reduced rating arresters can be applied. Full-rated arresters are required generally on ungrounded neutral systems or systems grounded through impedance. The possibilities of system overvoltages should be investigated carefully in determining the minimum rating arrester that can be applied economically.
4. For effectively grounded systems insulation levels one class below the standard have given satisfactory service using reduced rated arresters particularly at voltages 115 kv and above.
5. Consideration should be given to shielding stations against direct lightning strokes. Where shielding is not practical, additional protection can be provided by installing protector tubes at the entrance to the station and at each transmission-line tower for a distance of $\frac{1}{2}$ mile from the station.

VI. PROTECTION OF DISTRIBUTION TRANSFORMERS

The distribution transformer with its protective devices is in effect a miniature substation constituting the final voltage transformation between the generating station and the individual customer's premises. Because the distribution transformer is small in size and comparative cost, and because it is usually pole mounted, often in out-of-the-way locations, its protective devices must be inexpensive, small in size and weight, simple, and reliable. The failures of early type distribution arresters and the large amount of lightning data obtained on distribution circuits furnish proof that the protective devices must also have the ability to withstand severe lightning discharges.

13. General Considerations

Distribution circuits are generally overhead construction and are, therefore, subject to lightning disturbances, the nature of which are discussed in detail in Chap. 16. Data collected over a period of years with surge-crest devices indicate that the majority of surge-current discharges on distribution circuits are relatively low in magnitude, less than 5000 amperes, but occasionally a discharge may exceed 100 000 amperes. More recent data collected with the fulchronograph show that some of the surge-current discharges that are moderate in magnitude may be long in duration, of the order of several thousand microseconds. See Chap. 16.

Experience has shown that lightning disturbances are more severe on rural circuits than on urban circuits, probably for two reasons. First, rural circuits are generally more exposed to lightning and, therefore, receive many more direct strokes. Second, because distribution transformers are less frequent on rural circuits—the drainage of long-duration surges through grounded transformer windings is less¹⁶.

These general conclusions have been borne out by operating experience with distribution lightning arresters. The failure rate of early arresters, attributed to lightning, that

were designed before high surge-current testing facilities were available was comparatively high. Later arresters, designed and tested to withstand high surge currents of about 100 microseconds duration have a good operating record on urban circuits. However, when these arresters were applied more extensively to rural circuits with sparsely located transformers, the failure rate increased. Modern arresters, designed with more emphasis on ability to discharge surges of long duration, have acquitted themselves well on rural circuits.

Most distribution transformers are pole mounted, one at a location, and are used to step the voltage down from a single-phase primary circuit (2300 to 13 200 volts) to a single-phase, three-wire, secondary circuit at utilization voltage, usually 120/240 volts. Occasionally they are used in three-phase banks to supply three-phase, low-voltage power. The primary circuits, whether single or three-phase, may be from a source having either a grounded or ungrounded neutral. If the neutral is ungrounded the single-phase primary consists of two of the ungrounded phase conductors, which means that the two primary terminals of the distribution transformer must be equally protected. If the neutral is grounded, the single-phase primary circuit will usually consist of one phase wire and the neutral conductor. The neutral conductor is usually grounded, so that only one high voltage terminal of the distribution transformer need be provided with protective equipment. The secondary will usually be three-wire, with the mid-point grounded.

A three-phase bank of distribution transformers may be connected delta delta, star delta, or delta star. With the delta delta connection, the secondary can have no common neutral. Sometimes, either one phase or the mid-point of one of the phases of the secondary is grounded. The star delta and delta delta connection are alike as far as the secondary delta connection is concerned. The primary neutral might or might not be grounded. The delta star connection usually has the common neutral of the star connected secondary grounded.

In addition to surge protection, the distribution transformer usually includes protection against internal short-circuit and secondary short-circuit or overloads consisting either of high-voltage fuses mounted external to the transformer, or high-voltage fuse links and a secondary circuit breaker mounted inside of and included as a part of the transformer.

The distribution transformer, like larger power transformers contains three groups of insulation subject to voltage stress, which should be considered in the protective scheme, namely:

1. The insulation between the high-voltage winding and the core or tank.
2. The insulation between the low-voltage winding and the core or tank.
3. The insulation between the high- and low-voltage windings.

There are, however, two conditions that make the protection of distribution transformers and high-voltage power transformers differ. These are the difference in the ratios of surge strength to operating voltage and the relative effects of locating and connecting the protective devices.

The distribution transformer (2400 to 13 200 volts) has a much higher ratio of surge strength to operating voltage, as Table I shows. As an example, the ratio of the basic insulation level to the peak of the 60-cycle voltage classification is $\frac{45}{2.5 \times \sqrt{2}} = 12.75$, for 2500 volt equipment, as against $\frac{650}{138 \times \sqrt{2}} = 3.33$, for 138-kv equipment. For this reason, it is permissible for the protective device in the low-voltage ratings to have a higher protective ratio than that required at higher voltages.

The effect of the location and connection of the protective devices is more pronounced with distribution transformers. Because lightning discharges on distribution circuits and on high-voltage transmission circuits are about equal in magnitude, the actual surge-voltage drops in the leads to the protective devices and through the ground connections of the two circuits are about equal. While these voltage drops may be only a portion of the discharge voltage of the protective device in the higher voltages, they may be several times the discharge voltage of the low-voltage protective device. It is extremely important, therefore, that protective devices on distribution circuits be located and connected properly with respect to the apparatus they are to protect.

14. Methods of Connecting Protective Devices

Three schemes of connecting protective devices to protect distribution transformers against lightning surges are commonly known:

1. Separate connection method.
2. Interconnection method.
3. Three-point protection method.

Separate Connection Method—This method of protection, universally used until about 1932, is illustrated in Fig. 37. Protective devices are connected between the pri-

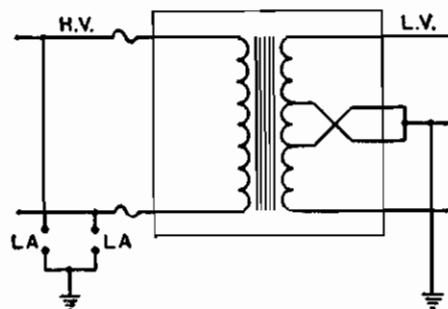

Fig. 37—Separate connection method of protecting single-phase transformers.

mary conductors near the transformer and a driven ground at the pole. The secondary neutral is usually grounded separately. With this connection, the protective devices are connected in series with a relatively long ground lead which has considerable inductance and is usually connected to a driven ground, the resistance of which may be high. The voltage, therefore, between the primary winding and ground is not only the discharge voltage of the arrester but also the impedance drop of the ground lead and ground

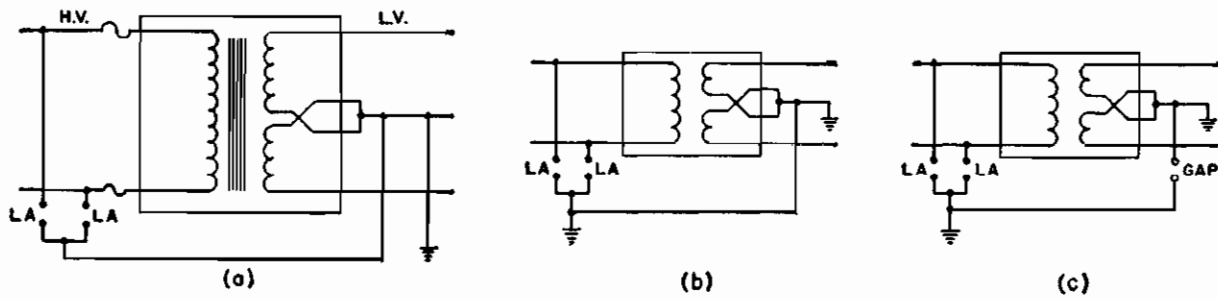

Fig. 38—Interconnection method of protecting single-phase transformers.

(a) Straight interconnection.

(b) Interconnection with protective ground at transformer.

(c) Interconnection with protective ground at transformer and insulating gap in interconnection.

connection, which may be several times the discharge voltage of the arrester. Failure or flashover of the transformer insulation may occur even though the actual surge voltage across the arrester is only a fraction of the transformer breakdown voltage. When this happens, the surge generally passes through to the secondary ground connection. The surge is usually followed by a flow of dynamic current until the primary fuse blows.

Interconnection Method—The straight interconnection consists of connecting the protective devices from the primary lines directly to the secondary neutral as illustrated in Fig. 38 (a). The surge voltage that can exist between the primary winding and the secondary is definitely limited to the discharge voltage of the protective devices. The potential of the core and tank, because of their electrostatic coupling to the secondary winding, normally rises along with the primary and secondary windings during a surge discharge and thus limits the voltage between the windings and core. This connection is an improvement over the conventional connection because it eliminates the factor of voltage drop in the arrester ground lead. Operating experience supports this conclusion¹⁷.

Two decided disadvantages prevent universal application of this scheme of connection. First, the protection between windings and core or tank depends upon the tank rising in potential with the windings. Actually, practical conditions might keep this from happening. The resistance to ground of the wood pole on which the transformer is mounted may be low enough to supply the small charging current required to keep the tank at ground potential. Also, as it rises in potential, the tank may flashover to a nearby guy wire or other grounded object. Either condition results in the application of the full potential of the surge between the windings and tank until the insulation breaks down or the secondary flashes over to the tank.

The second disadvantage of this connection is that it directs the entire primary surge voltage into the secondaries, which is undesirable, particularly if the resistance of the secondary grounds is not low. This restriction makes the straight interconnection in general unapplicable to rural circuits or other circuits that might not have the secondaries effectively grounded.

A modification of the straight interconnection is shown in Fig. 38 (b). Here, a ground is made at the arrester location also. The protection provided the transformer insulation depends upon the tank being insulated from

ground, or, if not, upon the magnitude of voltage drop in the arrester ground lead and connection. The arrester ground is in parallel with the secondary ground so that the complete surge is not directed to the secondary. The direct tie between the arrester ground and secondary is undesirable unless the secondary is effectively grounded, again making the connection generally unapplicable to rural circuits.

Another modification that eliminates the permanent tie between the arrester ground and secondary neutral is shown in Fig. 38 (c). An isolating gap, having low flashover, breaks the direct tie. A rise in potential between windings during a surge discharge breaks down the gap and limits the voltage between windings to the arrester discharge voltage. The protection of the transformer insulation to the core or tank still depends upon the tank being insulated from ground, or, if not, upon the voltage drop in the arrester ground lead and connection being low.

Three-Point Protection Method—This scheme, illustrated in Fig. 39 (a), definitely limits the voltage across the three groups of insulation in the transformer independently of ground connections or resistances. The protective devices connected between the high-voltage lines and tank definitely limit the voltage between those parts to the discharge voltage of the protective device. Likewise, the protective device between the secondary and tank (usually a gap for 480 volts and below) limits the voltage between those parts to the breakdown voltage of the device. With the voltage between the high-voltage winding and core or tank and the voltage between the low-voltage winding and core or tank definitely limited, the voltage between the two windings is also limited.

Referring to Fig. 39 (a), a surge coming in over a primary lead raises the potential of the primary winding to the breakdown of the protective device that discharges to ground. If the arrester-ground impedance is high or if there is no ground at that point, the potential of the high-voltage winding rises above that of the core and tank until the gap *TG* breaks down and limits the voltage between the winding and tank to the discharge voltage of the arrester plus the gap. If the voltage between the tank and secondary exceeds the breakdown of the gap *TN*, the gap operates and discharges to the secondary ground. The gaps, *TG* and *TN*, while they definitely isolate the tank from the primary and secondary ground connection dur-

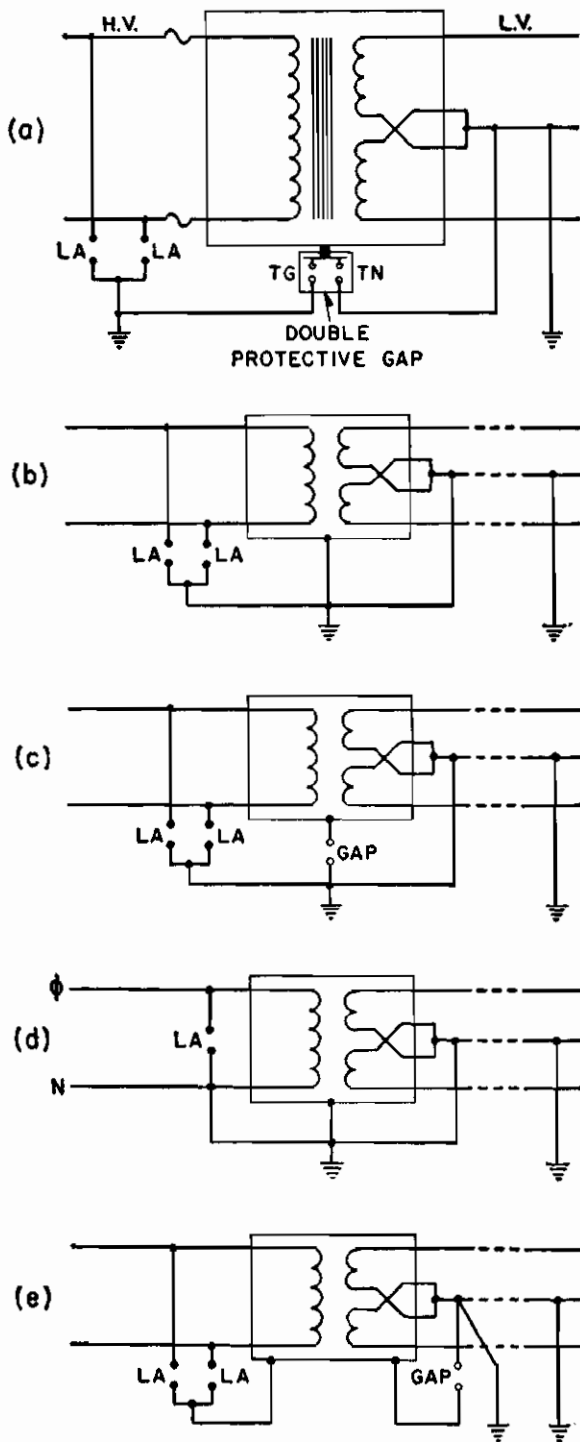

Fig. 39—Three-point protection method.

- (a) Three-point protection with insulating gaps.
- (b) Three-point protection simplified circuit.
- (c) Three-point protection with single insulating gap.
- (d) Three-point protection of single-phase transformer on four-wire, grounded-neutral circuit.
- (e) Three-point protection with insulated tank.

ing normal operation, do not greatly add to the surge voltage impressed across the winding insulation. The three-point scheme of protection thus provides definite

protection to the three groups of insulation in the transformer independently of the arrester or secondary grounding conditions, whether the tank is insulated or not, or whether the surge originates on the primary or secondary.

Variations in the methods of connecting the protective devices to obtain three-point protection are shown in (b), (c), (d), and (e) of Fig. 39.

15. Protection of Three-Phase Transformer Banks

The shortcomings of the separate connection method of protection apply equally well to the protection of three-phase transformers or three-phase transformer banks on distribution circuits. The interconnection method is generally not applicable because there is no secondary neutral unless the secondary is connected in star. Sometimes one phase of the secondary or the midpoint of one of the phases is grounded as shown by the broken lines of Fig. 40.

The three-point scheme of protection, illustrated in Fig. 40, is applicable to any winding connection. A pro-

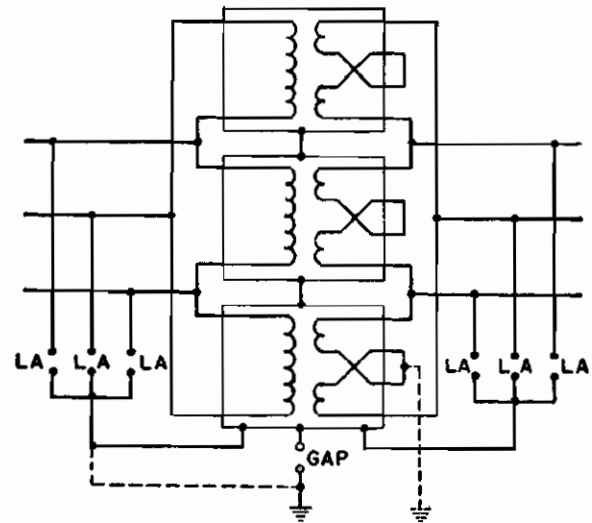

Fig. 40—Three-point protection applied to three-phase distribution transformers.

tective device is connected between each primary phase winding and tank either directly or through an isolating gap. Likewise, a protective device (air gap or coordinated secondary bushing for 480 volts and below) is connected between each secondary phase lead and the tank. The tanks of all transformers in the bank are tied together. With this connection, the windings of all transformers are protected irrespective of grounding conditions or whether the surge originates on the primary or secondary circuit.

16. Surge Voltages in Secondary Circuits

Overhead secondary circuits are, to some extent, subject to lightning surges originating on the secondary. They can also experience surges passing from the primary into the secondary. The separate connection, Fig. 37, isolates the primary from the secondary. However, when the transformer fails or flashes over as a result of a primary surge, the surge passes directly on to a phase wire or neutral of the secondary circuit. The primary-system

voltage is also impressed on the secondary until the primary fuse blows. The straight interconnection directs all the primary surge on to the secondary neutral. With the modified interconnection shown in Fig. 38 (b) or with the three-point scheme of protection, some of the surge may pass on to the secondary neutral, depending upon how effectively the primary protective devices are grounded.

Experience has shown that damage caused by surges on secondary house circuits is negligible. Where long exposures and relatively high secondary insulation may result in damage, protection should be provided by low-voltage protective devices located at the house entrance, and connected between the phase wires and neutral, which is usually grounded. All grounds on the customer's premises should be connected together. In case the secondary is not grounded in the customer's premises, such as may be the case with a three-phase, four-wire delta circuit, the danger of damage is greater than with the usual house circuit. Where the hazard is considered serious, it can be eliminated by connecting a protector between each phase wire and ground at the house entrance, or preferably right at the apparatus to be protected.

Three-phase, 440-volt circuits sometimes extend a considerable distance overhead to motor circuits, thus constituting a hazard to the motors and associated starting equipment. They can be protected by connecting a low-voltage protective device between each phase wire and the frame of the apparatus, which should be grounded. Protectors connected to the secondary at the transformer will generally not provide adequate protection to the load apparatus.

17. Protective Devices for Distribution Transformers

Three general classes of devices are used for the protection of distribution transformers just as for the protection of high-voltage substations, namely, the plain air gap, the protector tube, and the conventional valve-type lightning arrester. However, the lower operating voltages, the higher ratio between insulation breakdown voltage and operating voltage, and the requirement that the device be small in size and cost, make the design and application of protective devices somewhat different for distribution transformers than for higher voltage equipment.

Plain Air Gap—Plain air gaps or fused gaps are sometimes used to protect distribution transformers. The relatively high insulation strength of the transformer makes it possible to provide a fair degree of protection to the transformer against lightning surges without having to decrease the gap spacing to a value where numerous flashovers occur as a result of minor surges. However, the device will not restore power voltage (above 480 volts) after a discharge without momentarily deenergizing the circuit, which usually results in the blowing of a fuse, either at the transformer, or at a sectionalizing point on the line. The gap spacings associated with low operating voltages are necessarily low so that unless the gap is enclosed or protected, numerous flashovers can occur as a result of birds or foreign objects bridging the gap. Double gaps of various constructions are sometimes used to minimize this trouble. Since distribution transformers

are often located in remote locations, it is important to avoid as many fuse replacements as possible. For that reason and because of the somewhat questionable protection obtained for surges of steep wave front, plain air gaps or fused gaps are not extensively used to protect distribution transformers.

Protector Tubes—The distribution-type protector tube, introduced about 1931, consists essentially of a small air gap, a diffuser tube, and sometimes a resistor, all connected in series. The series gap is just enough to insulate the tube from normal power voltage, thus eliminating a continuous voltage stress across the diffuser tube. The purpose of the series resistor when used is to limit to approximately 500 amperes the one-half cycle of power

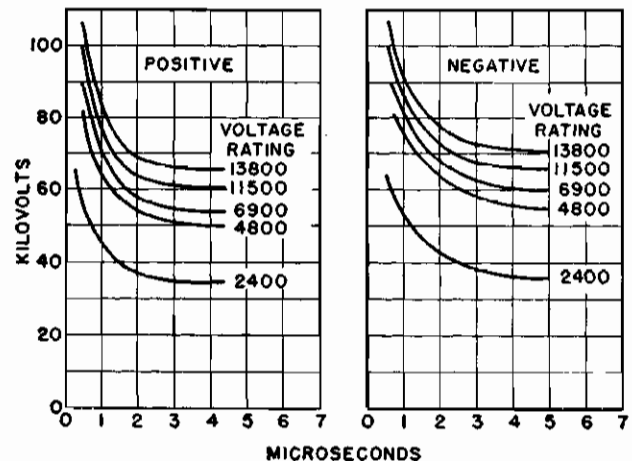

Fig. 41—Volt-time breakdown characteristics of one type of distribution type protector tubes.

current that may follow the surge discharge, thus making the application of the tube independent of the system short-circuit current.

The gap breakdown characteristics of the different voltage ratings of a typical type of protector tube are shown in Fig. 41. After the gap breaks down, the discharge voltage is equal to the arc drop in the tube plus the drop across the series resistor, if one is used. The series resistor is generally provided with a shunt gap that limits the voltage across the resistor to about 30 kv. If the lightning surge is of sufficient current magnitude to build up a resistance drop of 30 kv across the resistor the shunt gap flashes over and takes the resistor out of the discharge circuit in which case the discharge voltage is the arc drop through the tube. Surge currents high enough to cause the shunt gap to flash over, produce sufficient deionizing action in the diffuser tube to cut off after the discharge without the one-half cycle of power-follow current.

Although the gap breakdown voltage of the protector tube is higher than that of a corresponding valve-type lightning arrester, particularly at short time lags, the tube adequately protects modern distribution transformers rated 13 800 volts and below if connected properly. Laboratory tests and operating experience have demonstrated the ability of a tube to discharge severe strokes of lightning. This characteristic together with its ability to

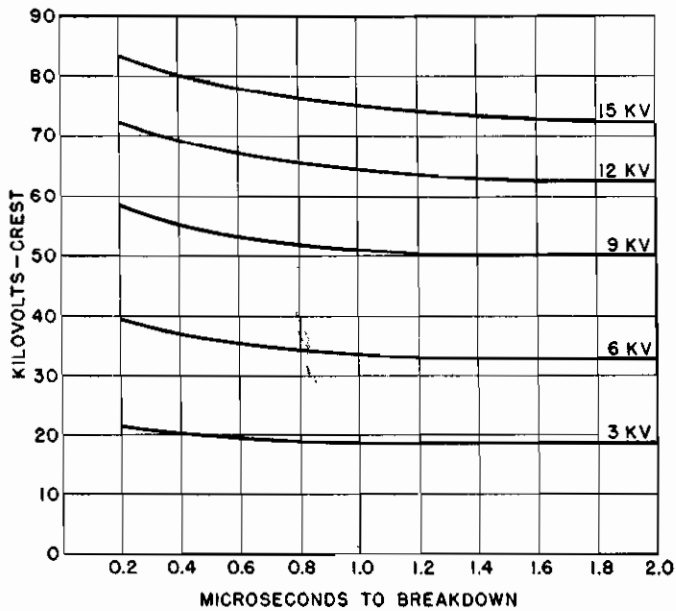

Fig. 42—Gap breakdown characteristics of typical distribution type arresters for $1\frac{1}{2} \times 40$ microsecond voltage wave.

withstand high momentary system voltage makes it especially well suited for application on rural circuits.

Conventional Valve-Type Lightning Arresters—

The valve-type lightning arrester is the device most generally used for the protection of conventional distribution transformers, that is, transformers requiring separately mounted protective devices. The curves of Fig. 42 and Fig. 43, show respectively the gap breakdown characteristics and the discharge characteristics of typical modern distribution-type arresters.

Operating experience of several years has demonstrated the ability of conventional valve-type arresters to provide a high degree of protection to distribution transformers. Modern construction has eliminated the mechanical difficulties experienced with early designs, which resulted in a relatively high failure rate and occasional radio-interference complaints. Field measurements of surge-crest magnitudes together with laboratory tests led to later designs having the ability to discharge surge currents of

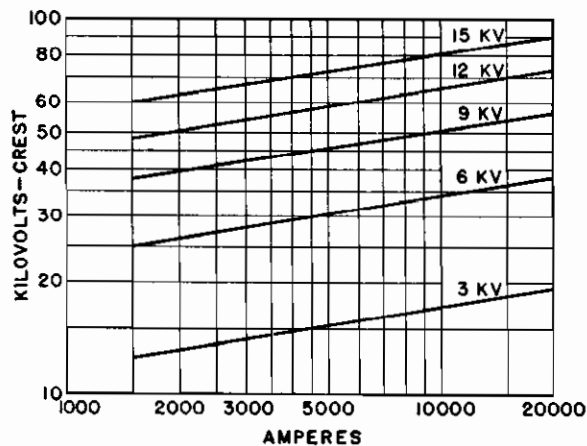

Fig. 43—Discharge voltage characteristics of typical distribution type arresters for 10×20 microsecond current wave.

high crest magnitude. More recent data obtained with the fulchronograph have shown that the distribution-type arrester should also be capable of discharging surge currents of long duration.

Valve-type lightning arresters are now available that will handle either surges of high crest magnitude or long duration.

Surge-Proof and CSP Transformers—The surge-proof distribution transformer, containing, as a part of the transformer, devices for complete surge protection, was introduced in 1932. An expulsion tube arrester, known as the De-ion arrester was connected between each primary terminal and tank. These arresters and the coordinated low-voltage bushings of these transformers together provided the three-point method of surge protection which for the first time gave the means for completely protecting all three major insulations.

These surge-proof transformers still required external fuse cutouts to disconnect the transformer from the line in case of secondary overload or short circuit or internal failure. Blowing of these fuses and sometimes failure of

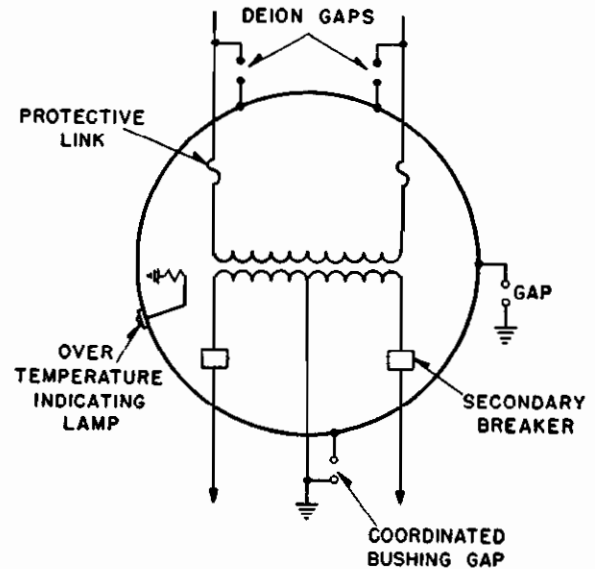

Fig. 44—Circuit diagram of CSP transformer.

If practice is to ground tanks, remove tank discharge gap and connect tank directly to ground.

the cutout constituted a large share of the trouble experienced with distribution transformers caused by lightning surges. Fuses cannot always be depended on to give adequate overload and short-circuit protection. Also, the mounting of cutouts necessarily adds to the cost and complication of installation of the transformer.

The completely self-protecting (CSP) distribution transformer, introduced in 1933, overcame these difficulties. Like its predecessor, it contained complete lightning protection, provided by high-voltage De-ion arresters and low-voltage coordinated bushings arranged to give three-point protection, as shown in the circuit diagram of Fig. 44. In addition, an internal circuit breaker connected between the low-voltage windings and low-voltage terminals protected the transformer against overload or secondary

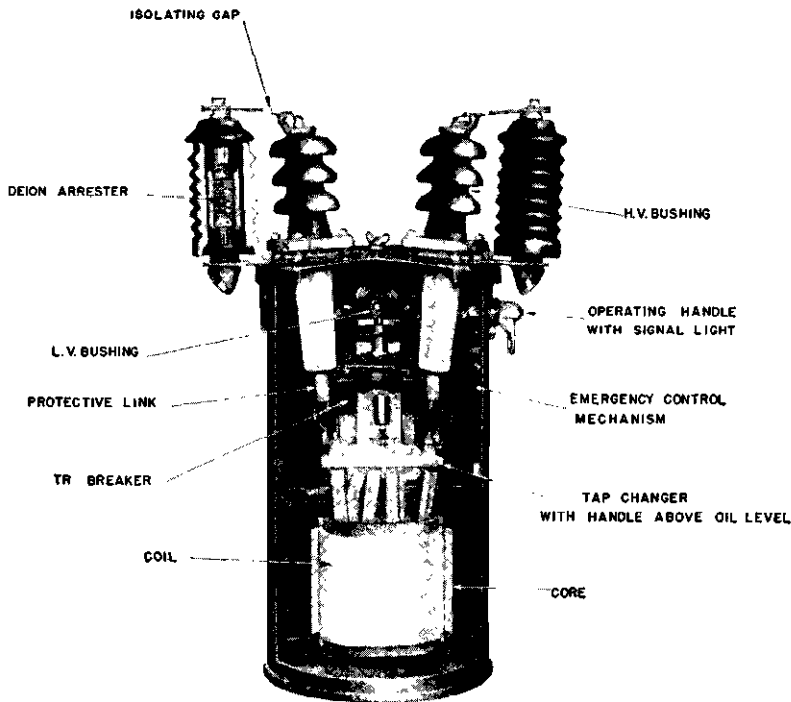

Fig. 45—Sectional view of CSP transformer for operation on grounded-neutral circuit.

short circuits. Finally, protection to the high-voltage feeders from internal transformer failures was given by internal protective links connected between the high-voltage winding and bushing. The internal breaker and protective links perform all of the functions of the fuse, so that with these transformers no external protective devices are required. Those transformers have now almost entirely superseded the surge-proof design.

The bimetallic tripping element of the breaker, which is actuated by both load current and oil temperature, is calibrated to follow closely the permissible thermal load-time characteristics of the transformer windings and provides loading on the basis of copper temperature.

A sectional view of a CSP transformer with two cover bushings and De-ion arresters is illustrated in Fig. 45. Of special interest is the emergency control now supplied on these transformers. This device takes care of the occasional situation where the breaker cannot be kept closed after having been tripped by overload, because the overload persists or motor starting currents are high. If it is imperative that service be restored, even at the risk of some loss of transformer life, the breaker setting may be elevated by means of the external emergency control handle to permit additional overloads. The necessity for the use of this device usually indicates that the load growth has exceeded the capacity of the transformer so that the unit should be replaced as soon as possible by a larger one.

Recent developments include the extension of the CSP principle to include three-phase distribution transformers and both single- and three-phase completely self-protecting transformers for banked secondary operation (CSPB's). The latter contain all of the protective features of the CSP transformers, and, in addition, they are supplied with two

breakers instead of one. These are interconnected within the transformer so as to sectionalize the low-voltage circuits in case of faults or overloads.

The CSP transformer is completely assembled in the factory thus making it possible to surge test the combined transformer and protective equipment. Proof of coordination of the insulation of each CSP transformer is now given by applying to each assembled unit a surge test equivalent to a direct stroke of lightning²⁰.

VII. SURGE PROTECTION FOR ROTATING MACHINES

The insulation on the windings of rotating machines, such as large or small motors, a-c generators, and synchronous condensers, is held to a minimum because of limited space. Also, since the insulation is not immersed in oil, its surge strength is not much greater than the peak of the 60-cycle voltage breakdown. Special measures are, therefore, necessary to protect such equipment when it is connected to a system subject to the hazards of lightning-surge voltages. Likewise, the method of grounding effects the overvoltages, during fault conditions and switching, which may be impressed on rotating machines; these phenomena are discussed in Chapters 14 and 19.

The stress on the major insulation of any machine, that is, the insulation between the winding and frame, is determined mainly by the magnitude of the surge voltage to ground, whereas the stress on the turn insulation is more a function of the rate of rise of surge voltage as the surge penetrates the winding^{21,22}. Protection of a rotating machine, therefore, requires limiting the surge voltage magnitude at the machine terminals and sloping the wave front of the incoming surge.

The effect of sloping the wave front is illustrated in Fig. 46. The curves of Fig. 46 (a) show the relative volt-

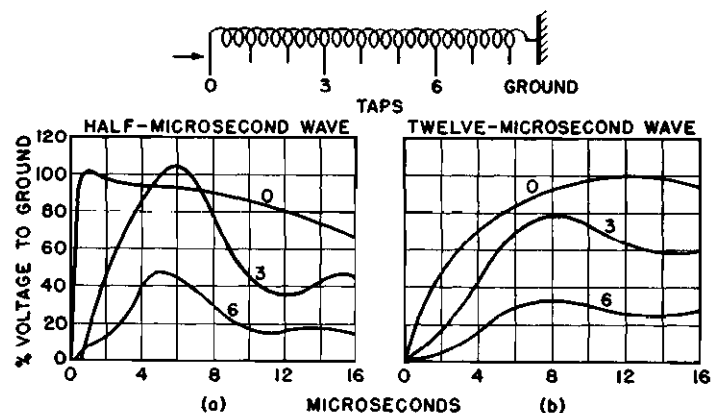

Fig. 46—Distribution of surge voltage in generator winding.

(a) Without rotating machine protection.

(b) With rotating machine protection.

ages to ground of the line terminal and two intermediate points in a phase winding of a machine without protection for an incoming surge rising to crest in one-half microsecond. The differences in voltages at the various points in the winding result in high stresses between turns. The curves of Fig. 46 (b) show how the stresses between turns are decreased by sloping the wave front so that the surge at the machine terminals reaches crest in twelve microseconds.

Limiting the surge voltage to ground sufficiently to protect the major insulation usually requires a special lightning arrester, having a low protective ratio, connected between each machine terminal and grounded

frame. Where more than one machine is connected to a common bus, one arrester connected between each phase of the bus and ground generally is adequate if the machine frames are connected to a low-resistance ground common with the arrester ground.

Sloping of the surge wave front is accomplished by letting the surge, after passing through a series impedance, charge a shunt capacitor connected to the machine terminals.

18. Line Surge Impedance and Capacitor Method

In this scheme of protection, a special arrester is installed at the machine terminal to limit the magnitude of the voltage impressed on its windings. The sloping of the surge is accomplished by a capacitor charged through the surge impedance and reactance of the line. See Fig. 47. To limit the voltage that determines the charging rate of the capacitor, a lightning arrester or protector tube is placed on each overhead line far enough ahead of the machine so that the arrester will discharge before the voltage impressed on it is modified by reflections from the capacitor. This distance will depend upon the slope of the incoming surge. The farther out the arrester is located, the less will be the stress on the machine winding for surges originating beyond the arrester, but the greater will be the possibility of a surge originating between the line arrester and the station. A distance of 1500 to 2000 feet is a good compromise between the possibilities of a stroke within this area and the effect of distance on the charging rate of the capacitor.

The rate of rise of the surge reaching the machine is also a function of the amount of capacitance used. The maximum permissible rate of rise depends upon the velocity of propagation of the surge in the machine winding, the number of turns per coil, the turn length and the turn insulation. A study of many cases has indicated that the maximum rate of rise should be limited to a value such that, if the terminal voltage continues to rise, it will not equal the test voltage of the machine in less than 10 microseconds. Considering a minimum practical line surge impedance and a practical machine surge impedance, this requires at least $\frac{1}{4}$ microfarad of capacitance. It is independent of rated circuit voltage because the machine test voltage and the voltage limited by the line arrester are proportional to rated circuit voltage. However, in the construction of capacitors there is a limit to the minimum capacitance that can be obtained economically on a standard unit. For example, the standard 6900-volt unit contains $\frac{1}{2}$ microfarad, whereas the 13 800-volt unit contains only $\frac{1}{4}$ microfarad.

In an ungrounded machine, because of the possibility of reflections from the neutral point, the voltage may double at the neutral. To limit the voltage at the neutral as recommended, it is necessary to hold the rate of rise of the surge entering the machines to $\frac{1}{2}$ the recommended value, by using at least $\frac{1}{2}$, instead of $\frac{1}{4}$ microfarad. In Table 9 are given the recommended capacitances for various voltage classes from 650 to 13 800 volts. For 11 500 and 13 800-volt classes, two standard $\frac{1}{4}$ -microfarad units are recommended for ungrounded machines, whereas $\frac{1}{4}$ microfarad is sufficient for a grounded machine. Below 11 500

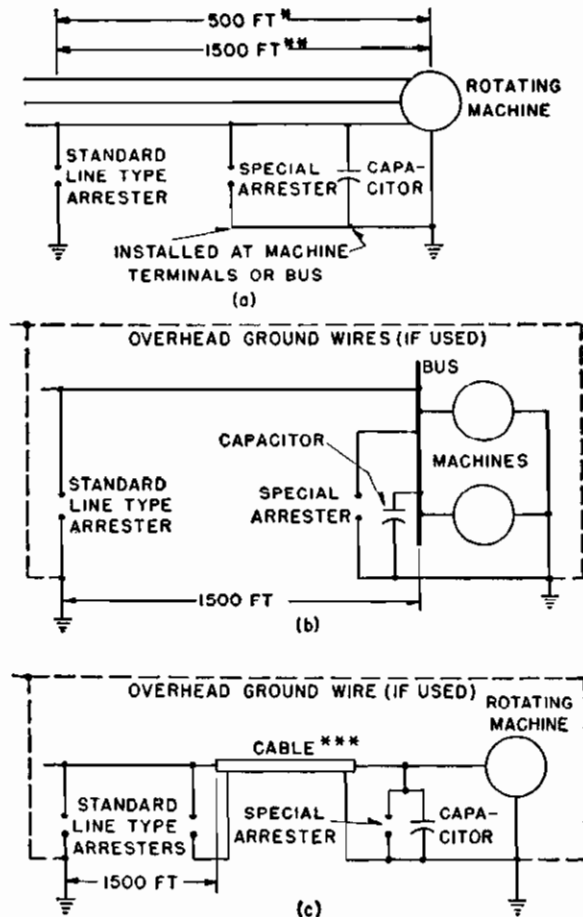

Fig. 47—Line surge impedance and capacitor method of protecting rotating machines.

- Single machine connected to overhead line.
- Two or more machines connected to common bus.
- Machine connected through short cable to overhead lines.

For simplicity, protective devices are shown on one phase only. Each phase however must have the same protective apparatus installed.

*For circuits below 2300 volts.

**For circuits 2300 volts and above.

***Cable lengths up to 1000 feet are considered short cables in this type of application. If the cable is over 2500 feet long and the machine is connected directly to it, it is satisfactory to omit the capacitor at machine terminals. In this case the capacity effect of the cable is approximately equivalent to the capacitor.

TABLE 9—RECOMMENDED CAPACITANCE VALUES FOR LINE SURGE IMPEDANCE METHOD OF PROTECTING ROTATING MACHINES

Circuit Voltage	Machine* Neutral Connection	Number of Standard Units per Phase	Microfarads in Each Standard Unit
650	any	1	2
2400	any	1	0.5
4160	any	1	0.5
4800	any	1	0.5
6900	any	1	0.5
11 500	Grounded	1	0.25
11 500	Ungrounded	2	0.25
13 800	Grounded	1	0.25
13 800	Ungrounded	2	0.25

*Machine neutral considered grounded if grounded through a resistor of 50 ohms or less. Reactance grounded machines should be considered ungrounded.

volts, the standard unit contains $\frac{1}{2}$ microfarad so no increase is required for ungrounded machines. In some applications it may be expedient to use an arrester from the neutral point of the machine to ground.

For all machines larger than 1000 kva, special station type arresters should be used at the generator terminals. For machines of less than 1000 kva station type arresters may not be justified economically. Special line-type arresters can be used.

In all cases, standard line-type arresters or protector tubes are placed out on every overhead line entering the station at generator voltage. For 2300-volt circuits and above, these arresters should be located approximately 1500 feet from the station. For voltages below 600 volts, these arresters can be located within 500 feet of the station.

The possibility of a lightning stroke to the line near the station can be minimized by overhead ground wires placed over this part of the line as indicated in Fig. 47 (b). Their spacing and location, with respect to the phase wires, is important and the application requires special study. There is a limit, however, to what can be done with ground wires. It should be stressed that the lightning strokes terminating on low-voltage circuits are just as severe as those terminating on high-voltage circuits. Therefore, to get good protection with overhead ground wires, the equivalent of a high-voltage line, with large spacing and increased surge insulation from line wires to ground conductors should be used for the first 1500 or 2000 feet from the station. Properly applied ground wires then are expensive on low-voltage circuits, especially if considerable money has to be spent to decrease the ground resistance. In many cases, it is more economical to use the choke-coil scheme of surge protection.

If the machine is connected to the overhead line through a short cable, Fig. 47 (c), the protection at the machine should be the same as discussed above. In addition there should be a set of line-type arresters on the line 1500 to 2000 feet from the cable pothead and another set at the cable pothead. If several cables are connected to the bus or machine and their total length exceeds 2500 feet the cable capacity acts to slope the wave front, and the capacitor can be omitted at the machine.

19. Choke Coil and Capacitor Method

The most complete protection of rotating machines connected directly to overhead lines is obtained when lightning arresters are used to limit the magnitude of the incoming surge, and lumped inductance and capacitance are used to limit the slope of the incoming surge. With this scheme of protection, the machine is given full protection for all surges, even for direct strokes to the overhead line close to the station.

Special lightning arresters are paralleled with the required amount of capacitance and tied to the generator terminals or station bus. See Fig. 48. A standard arrester is applied on the line side of the choke coil to limit the

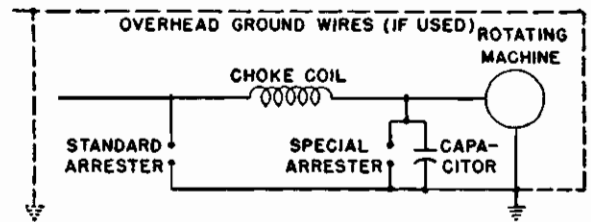

Fig. 48—Choke coil and capacitor method of protecting rotating machines.

voltage that determines the charging rate of the capacitor. The rate of rise of the terminal voltage depends upon both the amount of inductance and amount of capacitance used. The values that should be used to limit the rate of rise to the maximum permissible value are given in Table 10. A study has shown that the minimum capacitance to use in conjunction with a 175-microhenry choke is $\frac{1}{2}$

TABLE 10—RECOMMENDED CAPACITANCE VALUES FOR CHOKE COIL AND CAPACITOR METHOD OF PROTECTING ROTATING MACHINES

Circuit Voltage	Machine* Neutral Connection	Number of Standard Capacitors per Phase	
		175 μ h Choke	350 μ h Choke
650	any	1	..
2400	Grounded	1	..
	Ungrounded	2	1
4160	Grounded	1	..
	Ungrounded	2	1
4800	Grounded	1	..
	Ungrounded	2	2
6900	Grounded	1	..
	Ungrounded	2	1
11 500	Grounded	2	1
	Ungrounded	4	2
13 800	Grounded	2	1
	Ungrounded	4	2

*Machine neutral considered grounded if grounded through a resistor of 50 ohms or less. Reactance grounded machines should be considered ungrounded.

microfarad for grounded machines. If the inductance is increased to 350 microhenries, $\frac{1}{4}$ microfarad would be sufficient.

For all machines above 1000 kva, special station-type arresters should be used at the generator terminals—whereas below 1000 kva special line type arresters can be used. In all cases, standard line or station-type arresters are located on the line side of the choke coil. Station-type arresters are recommended, but, where it is not felt that they can be justified, line-type arresters can be used; the degree of protection expected will dictate the arrester to use.

This scheme is more expensive, but gives decidedly more reliable protection because the area close to the station is fully protected.

20. Machines Connected to Overhead Lines Through Transformers

Experience with machines connected to overhead lines through transformers has indicated that damage to the machines from lightning surges on the overhead lines is rare if adequate arrester protection is provided on the high-voltage side of the transformer. However, surges coming in over an overhead line may produce high voltages on the low-voltage side of the transformer, even if

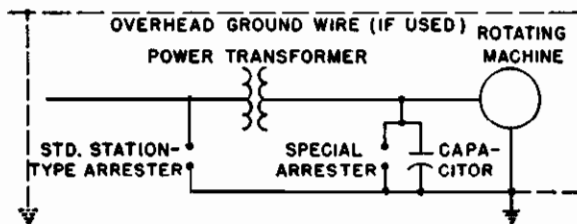

Fig. 49—Protection of rotating machines connected through power transformers to overhead lines.

the high side is adequately protected with arresters. The surge is transmitted through the transformer by both electrostatic and electromagnetic coupling. The electrostatic coupling depends upon the transformer capacitances between windings and to ground, and is independent of reactance and turns ratio. The electromagnetic coupling depends upon the turns ratio, reactance and size of the transformer, as well as the bank connection, that is, whether star-delta, star-star, etc.

Where additional protection to the rotating equipment is desired, it can be obtained by connecting a special arrester and one standard capacitor unit to each phase ter-

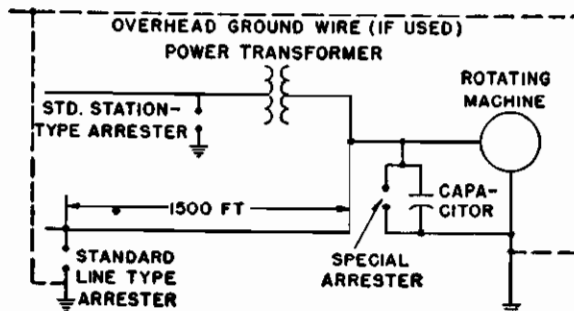

Fig. 50—Protection of rotating machines connected direct to and through transformers to overhead lines.

minal of the machine. A standard lightning arrester is, of course, required on the line side of the transformer to protect the transformer. See Fig. 49.

When the machine is connected to an overhead line both direct and through transformers, the special arresters and capacitors should be applied at each machine terminal the same as when the machine is connected to the overhead line only. Standard line-type arresters should be located from 1500 to 2000 feet out on the direct-connected line. Standard station type arresters should be installed on the high side of the transformer. See Fig. 50.

21. Machines Connected to Overhead Lines Through Feeder Regulators or Current Limiting Reactors

If the machine is connected to the overhead line through a feeder regulator or current limiting reactor, the protection should be the same as for a machine directly connected to the overhead line. In addition, a standard line-

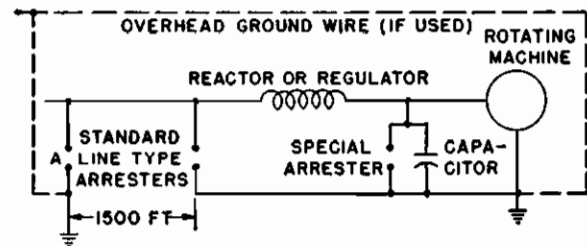

Fig. 51—Protection of rotating machines connected through current limiting reactor or feeder voltage regulator to overhead lines.

(A reactor, when present, is equivalent approximately to the effect of using a choke coil. Arrester A may be omitted if the current limiting reactor has an inductance of over 350 microhenries.)

type arrester should be added on the line side of the regulator or reactor. See Fig. 51.

If the inductance of the current limiting reactor is greater than 350 microhenries, the arrester on the line can be omitted.

22. Characteristics of Special Lightning Arresters

Special low-breakdown lightning arresters for connection in parallel with capacitors at the machine terminals (or at the bus if two or more machines are connected to a common bus) are available in either the station type or line type. The characteristics of typical arresters of both types are shown in Table 11. The station type arresters have a somewhat lower breakdown voltage, a lower discharge voltage at high surge currents, and a higher surge-current discharge capacity.

For the best protection, station-type arresters should be applied to machines of all ratings. However, it is recognized that applications involving small sized machines may not economically justify the most expensive protection. For that reason, line-type arresters are generally applied on machines 1000 kva and below, and station-type arresters on machines larger than 1000 kva.

Either arrester must be applied on the basis that the power voltage from line to ground across the arrester

TABLE 11—PERFORMANCE CHARACTERISTICS OF SPECIAL LIGHTNING ARRESTERS FOR SURGE PROTECTION OF ROTATING MACHINES

Type	Voltage Rating Kv Rms	Gap Breakdown			Discharge Voltages on 10×20 μs Wave 1500 Amp
		60 Cycle Kv Rms	Front of Wave Breakdown of Standard AIEE Rate of Rise, Kv Crest	Wave Front of 10 Microseconds to Breakdown Kv Crest*	
Special Station Type	3	8	12	9	9
	6	13	22	17	18
	9	21	30	26	27
	12	25	40	34	36
	15	30	50	42	45
Special Line Type	0.5	1.0	2.5	2.1	2.5
	0.75	1.6	3.4	3.0	3.4
	3	7	14	9	9
	6	14	25	18	18
	9	21	33	27	27
	15	34	55	45	45

*Breakdown when used with capacitor.

under any normal or fault condition does not exceed the arrester phase-leg rating.

VIII. SUMMARY

The problem of coordinating the insulation of electrical equipment has progressed through years of research from a subject only vaguely understood to a sound engineering practice based on well defined principles and known facts. Basic insulation levels have now been established that fix the lower limits of insulation surge strength to definite values that can be demonstrated by standardized test methods. Protective devices are available that will provide a high degree of protection to insulation meeting the basic levels. Effective schemes have been devised for protecting insulation that requires special consideration.

This progress was made possible only by cooperation between the manufacturers and users of electrical equipment in obtaining invaluable information on the nature of lightning and its effects on equipment in service. Continued cooperation will undoubtedly produce additional information that will make possible further improvements to the methods of coordinating insulation.

REFERENCES

1. Standard Basic Impulse Insulation Levels, A Report of the Joint Committee on Coordination of Insulation A.I.E.E., E.E.I. and N.E.M.A. E.E.I. Publication No. H-8, N.E.M.A. Publication No. 109, *A.I.E.E. Transactions*, 1941.
2. *A.I.E.E. Lightning Reference Book 1918-1935*.
3. Coordination Session Toronto Convention 1930. Seven Papers *A.I.E.E. Transactions* 1930.
4. Recommendations for High-Voltage Testing, E.E.I.-N.E.M.A. Subcommittee Report, *A.I.E.E. Transactions*, Vol. 59, page 598.

5. Flashover Voltages of Insulators and Gaps, A.I.E.E. Subcommittee Report, *A.I.E.E. Transactions*, Vol. 53, page 882.
6. Flashover Characteristics of Insulation, P. H. McAuley, *Electric Journal*, July 1938.
7. Protection of Power Transformers Against Lightning Surges, A.I.E.E. Committee on Electrical Machinery, Transformer Subcommittee, Technical Paper 41-79.
8. Report on Apparatus Bushings, A.I.E.E. Joint Committee on Bushings, Technical Paper 41-76.
9. The Control Gap for Lightning Protection, Ralph Higgins and H. L. Rorden, *A.I.E.E. Transactions*, 1936, page 1029.
10. Line Type Lightning Arrester Performance Characteristics, A.I.E.E. Lightning Arrester Subcommittee, Technical Paper 41-138.
11. Station-Type Lightning-Arrester Performance Characteristics, A.I.E.E. Lightning Arrester Subcommittee, *Electrical Engineering*, June 1940.
12. Selection of Lightning Arrester Ratings, R. D. Evans and Edward Beck, *Westinghouse Engineer*, February 1942.
13. A Traveling Wave Primer, Edward Beck, *Electric Journal*, March 1932 to October 1932 inclusive.
14. Transmission Tapped for Distribution by New Unit, George S. Van Antwerp and H. S. Warford, *Electrical World*, 1938.
15. Shielding of Substations, C. F. Wagner, G. D. McCann and C. M. Lear. *A.I.E.E. Transactions*, Vol. 61.
16. Lightning and Lightning Protection in Distribution Systems, R. C. Bergvall and Edward Beck, *A.I.E.E. Transactions*, Vol. 59.
17. Distribution Transformer Lightning-Protection Practice, L. G. Smith, *A.I.E.E. Transactions*, Vol. 57.
18. Surge Proof Distribution Transformers, J. K. Hodnette, *Electric Journal*, February 1932.
19. Surge Protection for Distribution Transformers, J. K. Hodnette, *Electric Journal*, March 1936.
20. Direct-Stroke Protection of Distribution Transformers, H. V. Putman, *Electric Journal*, February 1937.
21. Protection of Rotating A. C. Machines Against Traveling Wave Voltages Due to Lightning, W. J. Rudge, Jr., R. M. Wieseman and W. W. Lewis, *A.I.E.E. Transactions*, Vol. 52.
22. Surge Protection for Rotating Machines, J. F. Calvert, A. C. Monteith, and E. Beck, *Electric Journal*, March 1933.
23. Application of Arresters and the Selection of Insulation Levels, J. H. Foote and J. R. North, *Electrical Engineering*, June 1937.
24. Application of Station-Type Lightning Arresters, A. C. Monteith and W. G. Roman, *Electric Journal*, March 1938.
25. The Insulator String, R. W. Sorensen, *A.I.E.E. Transactions*, 1934, Vol. 53.
26. Failure of Disk Insulators on High Tension Transmission Systems, H. D. Panton, *A.I.E.E. Transactions*, 1922, Vol. 41.
27. Transmission of Electric Power at Extra High Voltages, Philip Sporn, A. C. Monteith, *A.I.E.E. Transactions*, Vol. 66, 1947.
28. Corona Considerations on High-Voltage Lines and Design Features of Tidd 500-kv Test Lines, C. F. Wagner, Anthony Wagner, E. L. Peterson, I. W. Gross, *A.I.E.E. Transactions*, Vol. 66, 1947.
29. Transformers and Lightning Arresters—Tidd 500-kv Test Lines, F. A. Lane, J. K. Hodnette, P. L. Bellaschi, Edward Beck, *A.I.E.E. Transactions*, Vol. 66, 1947.
30. Flashover Characteristics of Rod Gaps and Insulators, A.I.E.E. Committee. *Electrical Engineering (A.I.E.E. Transactions)*, Vol. 56, June 1937, pages 712-14.
31. Lightning Performance of 200-kv Transmission Lines—II, A.I.E.E. Committee. *A.I.E.E. Transactions*, Vol. 65, 1946, pages 70-5.
32. The Characteristics and Performance in Service of High-Voltage Porcelain Insulators, J. S. Forrest, *Journal, Institution of Electrical Engineers (London, England)*, Vol. 89, part II, No. 7, February 1942, pages 60-80.

CHAPTER 19

GROUNDING OF POWER SYSTEM NEUTRALS

Original Author:

S. B. Griscom

Revised by:

S. B. Griscom

THE method of power-system grounding is perhaps more difficult to select than any other feature of its design. The large number of factors that must be considered is partly responsible, but primarily it is because most of these factors cannot individually be set up in terms of dollars and cents, and thus weighed, one against the other, to get the best compromise between conflicting influences.

Historically, there has been a gradual trend in American practice from ungrounded, to resistance grounded, to solid or effective grounded. The main reasons for these trends can readily be traced. Most systems were initially operated with their neutrals free, that is, not connected to ground. This was the natural thing to do as the ground connection was not useful for the actual transfer of power. The method had a strong argument in its favor, since an insulator failure on one of the phases could be tolerated for some little time until the fault could be located and repaired. Also most lines then were single circuit, and the free-neutral feature permitted loads to be carried with fewer interruptions than had the neutral been grounded and considerable fault current flowed. Another important consideration was that relaying had not come into general use, so that many prolonged outages were avoided by the ungrounded operation.

Limitations to ungrounded operation began to develop with the growth of systems, both as to mileage and voltage. This increased the currents when a ground occurred, so that an increasing proportion of transient grounds (from lightning, or momentary contacts) were no longer self-clearing. Furthermore, the phenomena of "arcing grounds" became prominent in the eyes of utility engineers. By arcing grounds was meant a process by which alternate clearing and restriking of the arc caused recurring high surge voltages. This phenomena proved quite elusive and long defied conclusive confirmation, but the theory gained many adherents, so that by 1920 the majority of systems were grounded either solidly or through resistance. Subsequently progress has been made in analyzing this phenomena, and recently an accumulation has been made of operating records of isolated-neutral systems. More recent transient-overvoltage comparisons between isolated and grounded systems have shown the former to give higher overvoltages, both during faults and switching operations, although not as high in magnitude as formerly suspected. Furthermore the operating records of ungrounded systems in recent years with proper surge protection and coordination of insulation do not show pronouncedly greater equipment failure rates than on the grounded systems. It therefore appears logical to conclude

that, while ungrounded operation is more hazardous to equipment than grounded, the degree of difference was somewhat masked by improvement in the apparatus itself while changeovers to grounded operation were taking place.

The first tendency in grounding was to limit the maximum amount of fault current by means of neutral resistances. A number of empirical formulas were advanced in an attempt to rationalize the procedure of determining the maximum value of resistance that could be used. These formulas were variously expressed in terms of line or cable lengths, charging current to ground, and some involved the connected generating kva of the system. More recent investigations seem to confirm that the maximum permissible neutral-grounding resistance is inversely proportioned to the total line-to-ground charging kva. However, it appears that other practical considerations, such as relaying, will dictate a lower maximum limit to grounding resistance than the arcing phenomena would require.

On systems whose voltage is higher than generated voltage, particularly 115 kv and above, a saving in system cost became available by the use of transformers having the insulation graded from the line terminal to the neutral, if the neutral was solidly grounded. The cost of the grounding resistor and the space required by it were also saved. Consequently, the next major trend, particularly in the transmission field, was toward solid or effective grounding. For the higher voltages, this is now the most prevalent grounding procedure in the United States.

In individual locations on some systems, particularly in the vicinity of 69-kv nominal system voltage, instances have occurred where high concentrations of power have led to ground-fault currents so high as to be deemed objectionable from the standpoint of conductor burning and inductive influence on communication circuits. In several of these instances, neutral-grounding reactors of moderate ohmic size have been used in the grounding of certain transformer banks.

In Europe, the last thirty years have seen considerable use of ground-fault neutralizers (Petersen coils). In many instances they have materially reduced outages caused by ground faults. There are about 50 installations in this country, most of which were made in the last 15 years, indicating an increasing interest.

I. FUNDAMENTAL PRINCIPLES OF SYSTEM GROUNDING

1. Ungrounded Systems

A simple ungrounded-neutral system is shown in Fig. 1 (a). The line conductors have capacitances between one

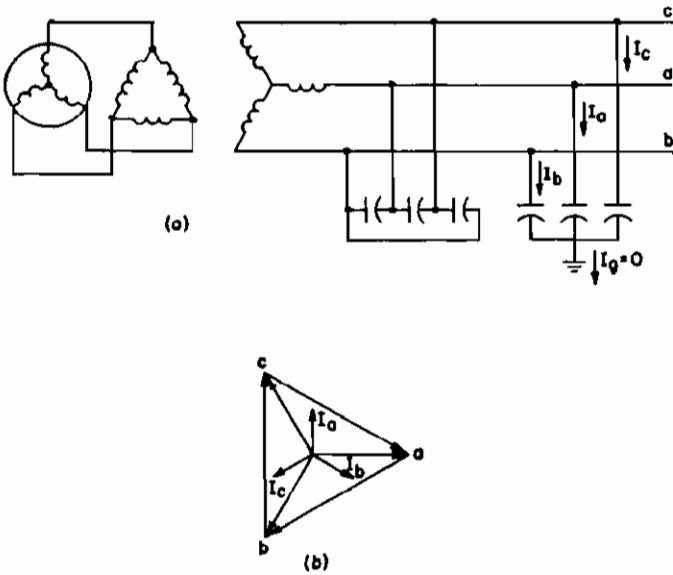

Fig. 1—Simple ungrounded-neutral system.

another and to ground, as represented by the delta- and star-connected sets of capacitances. The delta set of capacitances has little influence on the grounding characteristic of the system and will therefore thenceforth be disregarded.

In a perfectly transposed line, each phase conductor will have the same capacitance to ground. With balanced three-phase voltage applied to the line, the current in each of the equivalent capacitances will be equal and displaced 120 degrees from one another. The voltages across each branch are therefore equal and also displaced 120 degrees from one another. Consequently, there will be no potential difference between the neutral points of the supply transformer bank and that of the capacitances. These vector relations are shown by Fig. 1 (b). Since the neutral of the capacitances is at earth potential, it follows that the neu-

tral of the transformer bank is also at ground potential, being held there by the balanced electrostatic capacitance to ground. In a sense, the system is therefore capacitance grounded.

If one conductor, phase *a* for example, becomes faulted to ground, there will no longer be any current flowing in the capacity branch between that phase and ground, because the difference of potential no longer exists. However, the voltage across the other two capacity branches will increase because the voltage across them rises to phase-to-phase voltage. Moreover, as shown by Fig. 2 (b), the voltages to ground are no longer 120 degrees out of phase, but 60 degrees. Hence the sum of the currents is no longer zero, but is three times the original current to neutral. In phase position the current I_f flowing from the faulted conductor to ground, which is the usual convention, leads the original phase-to-neutral voltage by approximately 90 degrees.

The actual solution for voltages and currents is most conveniently carried out by means of the method of symmetrical components as given in Chap. 2. The current in the faulted phase is then

$$\frac{3E_\kappa}{Z_1 + Z_2 + Z_0}$$

In this connection, two points are of interest. Z_0 , the zero-sequence impedance at the point of fault will, for an ungrounded neutral system, be predominantly capacitive, whereas Z_1 and Z_2 are predominantly inductive. Consequently, the two tend somewhat to neutralize one another. On long lines, this is particularly so, as Z_1 and Z_2 increase with length, whereas Z_0 decreases. A further effect noted on long lines is that the zero-sequence charging currents must be drawn through the series reactance of intervening sections, causing a zero-sequence voltage rise toward the far end. This can result in the ground or "neutral" point lying outside of the triangle of line voltages as shown by Fig. 3. This situation is rarely

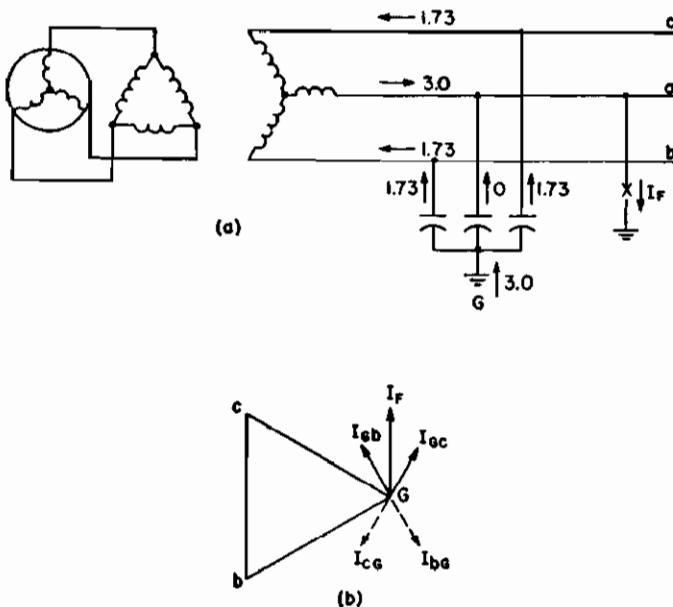

Fig. 2—Ground fault on simple ungrounded-neutral system.

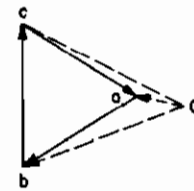

Fig. 3—Neutral displacement outside triangle of voltage on long lines.

of importance unless the line lengths exceed about 200 miles. If the generating capacity is small, the additional charging current caused by a ground fault may materially increase the phase-to-phase voltages.

The electrostatic capacitances of each line to ground were assumed in the discussion above to be the same. This will be substantially the case for a transposed line. With untransposed lines this will not be true, particularly if the configuration of the conductors is flat or vertical. The exact amount of unbalance can be calculated by determining the capacity coefficients of the conductors.* In extreme cases, the unbalance with either configuration may

*See Chapter 3.

give as much as five percent zero-sequence voltage. Therefore, in practice, the system neutral on an ungrounded-neutral system may be displaced from ground as much as five percent of the normal line-to-neutral voltage under unfaulted conditions. This may not be objectionable, although sometimes interference may be caused with communication circuits.

2. Resistance-Grounded Systems

A typical resistance-grounded neutral system is shown in Fig. 4. As commonly installed, the resistance has a

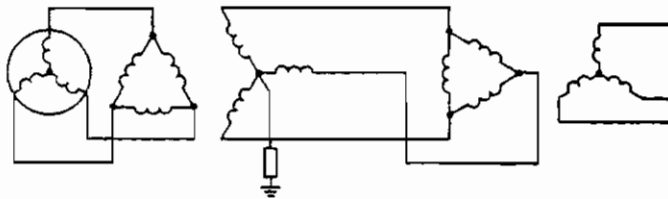

Fig. 4—Simple resistance-grounded system.

considerably higher ohmic magnitude than the system reactance at the resistor location. Consequently, the line-to-ground fault current is primarily limited by the resistor itself. Other than in exceptional cases, such as long lines at high voltage, or extensive cable systems, the capacitive current is small compared to the resistive current, and can be neglected.

An important consideration in resistance-grounded systems is the power loss in the resistor during line-to-ground faults. The power loss is shown in Fig. 5 as a percentage

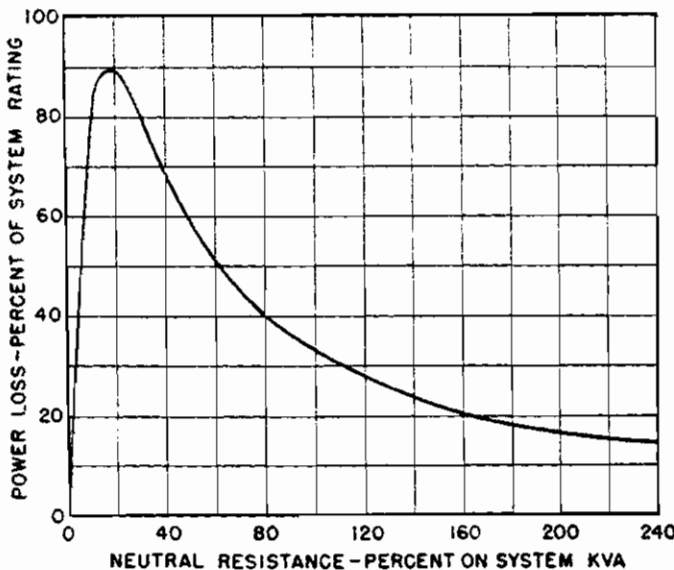

Fig. 5—Power loss in neutral resistor during line-to-ground faults.

of the kva rating of the entire connected generating capacity on the system, and as a function of the value of the neutral resistance. The latter is expressed in percent on the system kva. A generator reactance of 16 percent and a transformer reactance of 8 percent were used in the preparation of the curve.

For this example, $Z_0 = 3R + j8$; $Z_1 = 0 + j24$; $Z_2 = 0 + j24$. The per unit fault current is given by the expression $I_f = 300 / (3R + j56)$. The voltage developed across the grounding resistor is $I_f R$. The power loss in the grounding resistor is $I_f E_R$ or $I_f^2 R$. I_f and E_R are both in terms of normal values per phase. The power loss obtained by their product is therefore in terms of normal value per phase. Consequently, if the power loss in the resistor is to be expressed in terms of total three-phase system kva rating, it must be divided by three. Thus resistor power loss in percent is $I_f^2 R / 3$, when I_f is in per unit and R in percent.

The maximum power loss for this case is 89.3 percent of the system rated capacity if three times the resistance in the neutral has the same ohmic magnitude as the reactances determining the ground-fault current. If the generator reactances are lower, still higher power will occur during grounds and may cause violent swinging of generator phase position or instability. Resistances in this region are to be avoided, and since there is always some additional resistance in the fault, it is preferable that the grounding resistors alone be sufficient to carry well beyond the peak.

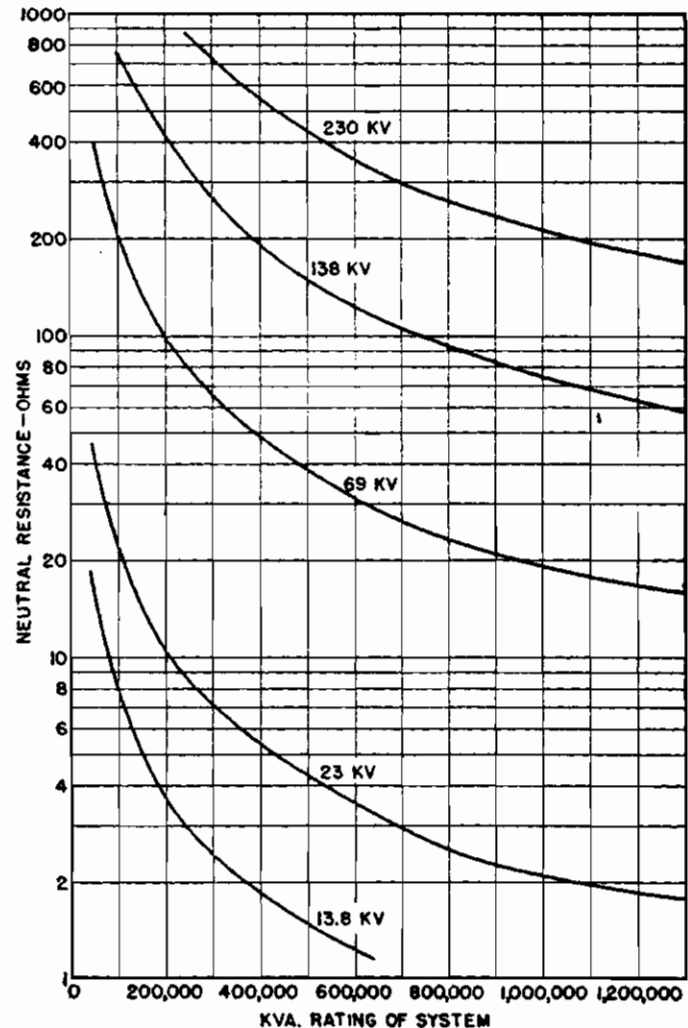

Fig. 6—Effect of system size and operating voltage on size of neutral resistor to limit ground fault current to one-quarter full-load system current.

The actual ohmic value of the grounding resistor required will vary widely depending upon the circuit voltage and system capacity. This effect is shown in Fig. 6, which assumes arbitrarily that the ground-fault current is to be limited to $\frac{1}{4}$ of full-load system current. By "full-load system current" is meant the summation of the rated currents of all generating capacity, converted to the voltage base of the line. In terms of the rated line currents, the fault currents may still be several times full load, depending upon the number of lines. Fig. 6 is principally for illustrative purposes, and quite wide variations from the resistor ohms shown are satisfactory in practice. It should be understood that the resistance value indicated by Fig. 6 is the paralleled value of all resistors, if multiple grounding is used.

3. Effectively Grounded Systems

The term "effectively grounded" has replaced the older term "solidly grounded," for reasons of definition. A transformer neutral may be "solidly grounded" in that there may be no impedance between the neutral and earth. However, the transformer capacity thus "solidly grounded" may be too small in comparison with the size of the system to be effective in stabilizing the voltages from phases to ground, when ground faults occur. This is particularly the case when small grounding transformers are used to provide a source of ground current for relaying.

The effect of different degrees of grounding is illustrated in considerable detail in Chap. 14. From Fig. 5, Chap. 14, the range of ground-fault currents is from 0 to 3.0 times the three-phase short-circuit current. As shown in Fig. 6, the line-to-ground voltage on an unfaulted phase ranges from about 0.6 to 2.0 times the normal line-to-neutral voltage during a line-to-ground fault. These figures are the rms dynamic quantities, as distinguished from transient voltages or currents.

These curves make it apparent that the term "solidly grounded" is too indefinite to describe a grounding procedure that varies over such a wide range. A designation in terms of the ratio of zero sequence to positive sequence reactance X_0/X_1 , is much more logical and definite.

Section 32-1.05 of AIEE Standard No. 32, May 1947, defines effective grounding as follows:

"A system or portion of a system can be said to be effectively grounded when for all points on the system or specified portion thereof the ratio of zero-sequence reactance to positive-sequence reactance is not greater than three and the ratio of zero-sequence resistance to positive-sequence reactance is not greater than one for any condition of operation and for any amount of generator capacity."

An example of an effectively grounded system is shown by Fig. 7. On the basis of generating capacity at station A

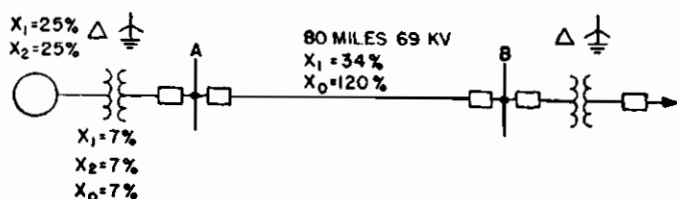

Fig. 7—Typical solidly grounded system.

only, the positive- and negative-sequence reactances for faults at station A are each $25+7=32$ percent, this being the sum of the generator and transformer reactances. The three-phase fault current is therefore $\frac{100}{32}=3.12$ times full-load current. The fault current for a single line-to-ground fault is $\frac{300}{32+32+7}=4.23$ times full-load current. The ratio X_0/X_1 is $\frac{7}{32}=0.219$.

For a fault at station B, 80 miles away, the positive- and negative-sequence reactances are increased by 34 percent and the zero-sequence reactance by 120 percent, by the transmission lines. The three-phase fault current is $\frac{100}{66}=1.51$ times full load. The single-phase fault current is $\frac{300}{66+66+127}=1.16$ times full load. The ratio X_0/X_1 is $\frac{127}{66}=1.92$.

The voltage of the sound or unfaulted phases can be conveniently read from Chap. 14, Fig. 6. For a fault at station A, where the ratio X_0/X_1 is 0.219, Fig. 6 shows that the line-to-ground voltage is approximately 0.9 of normal line-to-neutral voltage (R_0/X_1 is about 0.1 if there is no fault resistance). For a fault at station B, the corresponding ratio X_0/X_1 is 1.92 and the line-to-ground voltage on an unfaulted phase is about 1.15 times normal.

4. Reactance-Grounded Systems

AIEE Standard No. 32-1.08 states:

"Reactance Grounded—Reactance grounded means grounded through impedance, the principal element of which is reactance. (Modified from 35.15.215.)"

NOTE: The reactance may be inserted either directly, in the connection to ground, or indirectly by increasing the reactance of the ground return circuit. The latter may be done by intentionally increasing the zero-sequence reactance of apparatus connected to ground, or by omitting some of the possible connections from apparatus neutrals to ground."

As thus defined, "reactance grounded" implies the insertion of a reactance in the ground connection. Within this meaning a reactance-grounded system is not solidly grounded; it may or may not be effectively grounded, and it may or may not be resonant grounded. For the discussions in this chapter, "reactance grounded" is defined in terms of X_0/X_1 ratio, a system being reactance grounded if X_0/X_1 exceeds 3.0, but is less than the value necessary for resonant grounding. Thus defined, putting a low reactance between a generator or transformer neutral and ground such that X_0/X_1 remains less than 3.0 does not constitute reactance grounding. Similarly, if a grounding transformer has its neutral solidly grounded, but X_0/X_1 exceeds 3.0, the system is presumed to be reactance grounded.

The system of Fig. 7 can be converted to a reactance-grounded system if a reactor of sufficiently high reactance is connected between the transformer neutral and ground at station A. If a reactor having a 60-cycle reactance of

16 ohms is used, this will be the equivalent of 8.4 percent on 25 000 kva. When multiplied by 3 (See Chap. 2) and added to the transformer reactance of seven percent the zero-sequence reactance becomes equal to the positive- and negative-sequence reactances. The current for a line-to-ground fault at station A then becomes equal to that for a three-phase fault. If therefore, the high ground-fault current with transformers solidly grounded had necessitated circuit breakers with greater interrupting ability than required for three-phase faults, the addition of the reactor would make the larger breakers unnecessary.

300

At station B, the ground fault current is $66 + 66 + 152 = 1.06$ times full load. The ratio X_0/X_1 is $\frac{152}{66} = 2.30$.

From Chap. 14, Fig. 6, the maximum line-to-ground voltage on an unfaulted phase is about 1.18 times normal.

Thus, the addition of a neutral reactor at a generating station may equalize the three-phase and single-phase short-circuit currents without greatly changing the minimum line-to-ground fault current, or the voltage from maximum phase to ground.

The installation of such a nominal amount of reactance is not sufficient to change the classification of the system from effectively grounded to reactance grounded, inasmuch as excessive neutral displacements do not occur with ground faults. This applies particularly in the vicinity of station A, but to a lesser extent in the vicinity of station B.

If a 50-ohm neutral reactor is installed at station A, the effective zero-sequence reactance at that point becomes 86%. The ratio X_0/X_1 at station A is then $\frac{86}{32} = 2.7$. At

station B the ratio X_0/X_1 is $\frac{206}{66} = 3.1$. Therefore on the

basis of the AIEE definition cited above, the system would be regarded as effectively grounded at station A but not at station B. On the basis of the treatment in this chapter the system of Fig. 7, with the 50-ohm grounding reactor is considered reactance grounded.

5. Resonant-Grounded Systems

A resonant-grounded system is one in which the capacitance current is tuned or neutralized by a neutral reactor or similar device. The principle of operation of the ground-fault neutralizer is quite simple. As commonly used, the neutralizer is simply a tapped reactor connected between a transformer neutral and ground. When one phase of the system is grounded, a lagging reactive current flows from the neutralizer through the transformer to the fault and thence to ground. At the same time the capacitance current will be flowing from line to ground (See Sec. 1). The lagging current from the reactor and the leading current from line capacitance are practically 180 degrees out of phase and therefore the actual current to ground at the fault is equal to the difference between them. By properly tuning the reactor (selecting the right tap) the two currents can be made almost exactly equal, so that their difference is substantially zero. Under this condition the current in the fault is so small that in general the arc will not main-

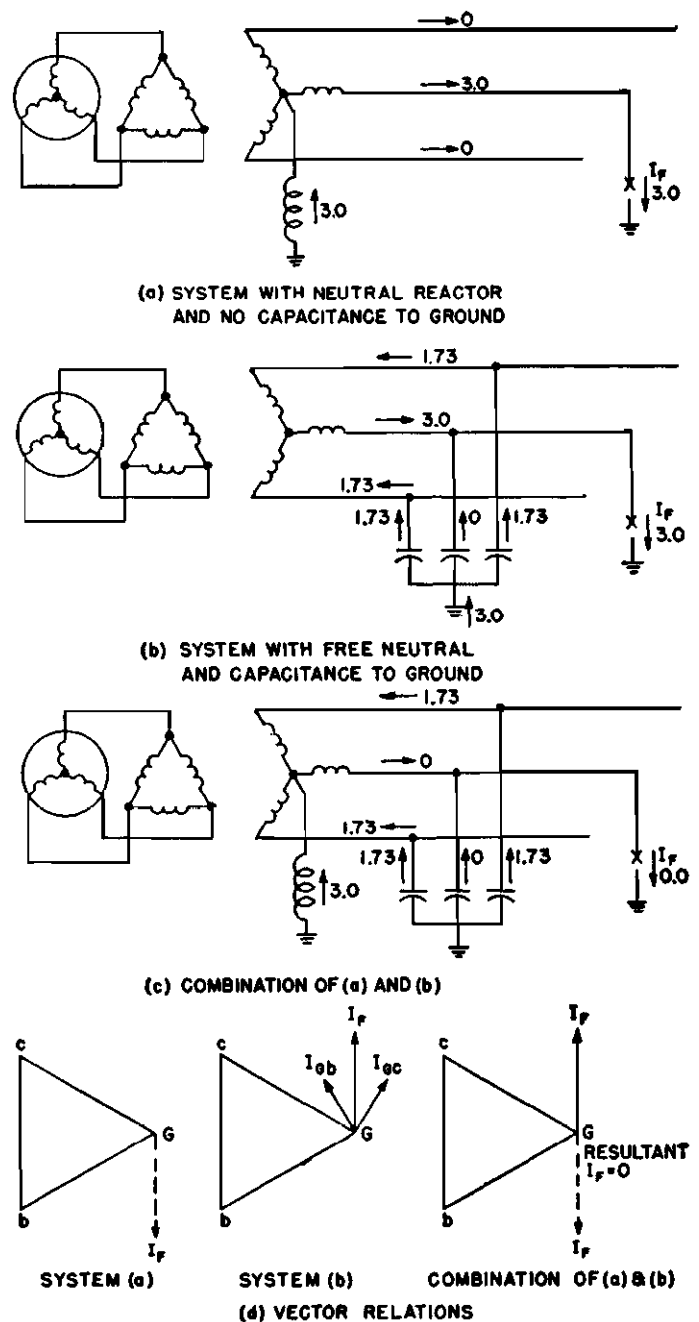

Fig. 8—Illustration of operation of ground fault neutralizer by principle of superposition.

tain itself, and the fault is extinguished or “quenched.” This condition is shown in Fig. 8.

When extinguishing a ground fault, the combination of neutralizer reactance and line capacitance constitutes a parallel resonant circuit. This is brought out clearly by the zero-sequence diagram as shown by Fig. 9. In this diagram X_L is the neutralizer inductive reactance and X_C the line capacitive reactance. “G” is an equivalent generator of zero-sequence voltage numerically equal to the system line-to-neutral voltage and X the fault. With X closed, there will be a current circulating between X_C and X_L but no current through the fault X. If X be assumed

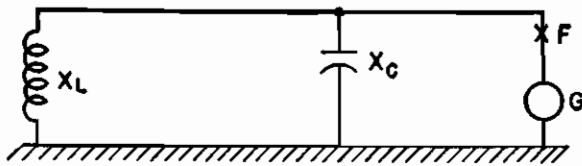

Fig. 9—Zero-sequence reactance diagram of system with ground fault neutralizer showing parallel resonant circuit where zero-sequence voltage is created by fault to ground.

to open, as by the extinguishment of the arc, the resonant combination of X_L and X_C will continue to produce an alternating voltage of about the same frequency and magnitude as the original applied voltage from G . Consequently, the actual voltage across the arc is small when it first extinguishes. This is a condition favorable to preventing restriking. In other words, the successful extinguishing of ground faults by neutralizers results in part from the low current and in part from the low voltage appearing across the arc when it goes through a "current zero."

It is of interest to note that the ground-fault neutralizer also constitutes a series resonant circuit in case there are any zero-sequence voltages on the system. In Sec. 1 on Ungrounded Systems, reference was made to the fact that with unsymmetrical line configurations a difference of several percent may exist in the charging current to ground of the three phases, resulting in a residual voltage. A zero-sequence voltage created by line or transformer unbalances is the equivalent of an actual source of voltage between the system neutral and ground, as shown in Fig. 10. Here

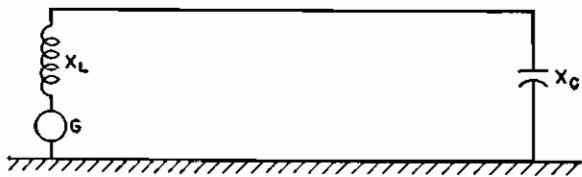

Fig. 10—Zero-sequence reactance diagram of system with ground fault neutralizer showing series resonant circuit where a zero-sequence voltage is created by unbalanced capacitances to ground.

X_C and X_L are the same as in Fig. 9, but the generator G equivalent to the zero-sequence voltage is now in series with the combination. The result of this connection is that a relatively small zero-sequence voltage is capable of producing a fairly high voltage across the reactor and capacitor. This, of course, causes the neutral to be considerably displaced, perhaps 10 or 15 times the amount of the original zero-sequence voltage. This situation must be watched in the application of ground-fault neutralizers, and if the fundamental frequency zero sequence voltage is in excess of about $1\frac{1}{2}$ percent, transposition of this line will probably be necessary.

Except for extremely long lines, the zero-sequence capacitive reactance alone can be used to calculate the current rating of the ground-fault neutralizer from the relation $I_t = \frac{3E_g}{X'_0}$, where I_t is the fault-to-ground current when operated with neutral isolated, E_g is the phase to neutral

voltage, and X'_0 is the zero-sequence capacitive reactance per phase.

The ground-fault neutralizer current rating is made equal to or greater than the total system charging current in a ground fault. A standard reference on methods of calculating these currents is the Joint *EEI* Bell Telephone systems report Vol. IV, Reports 26-38 dated January, 1937. However, it has been found that all the methods available for calculating this current invariably give lower than the corresponding measured ones. For results that are estimates, the data of Table 1 can be used:

TABLE 1—GROUND FAULT NEUTRALIZER CURRENT PER MILE OF SINGLE CIRCUIT OVERHEAD LINE

Voltage-Kv	Amperes
23	0.145
34.5	0.20
46	0.26
69	0.39

For double-circuit lines on the same tower or poles, reduce the particular line sections to equivalent single-circuit miles of overhead line by increasing the mileage by 1.3 for 34.5 kv and 1.6 for 69 kv lines.

For overhead ground wires, convert the particular line sections to equivalent single-circuit miles of overhead line by increasing the line mileage by 1.08 for one ground wire and 1.15 for two ground wires.

For cables, reduce sections to equivalent sections of overhead lines by the following factors:

1 mile of three-conductor cable = 25 miles of overhead line.

1 mile of single-conductor cable = 50 miles of overhead line.

The neutralizer selected should have a current rating at least 20 percent in excess of the maximum total current obtained by using the above figures.

On lines shorter than 200 miles calculations made in the above manner will be well within the engineering accuracy required. For longer lines, the zero-sequence inductive reactance of the line should be considered, as it may have some influence on the size of reactor required.

II. PRACTICAL CONSIDERATIONS IN SYSTEM GROUNDING

The broad objective in selecting a type of system grounding is to secure the best compromise of the conflicting advantages and disadvantages of the various methods. The first column of Table 2 lists items affected by the method of grounding. The subsequent columns give in abbreviated form the attributes of the particular type of grounding. The following sections discuss the features of the different methods of grounding in more detail.

6. Ungrounded Systems

The principal virtue of an ungrounded-neutral system is its ability, in some cases, to clear ground faults without interruption. The self-clearing feature disappears when the length becomes appreciable. This effect is one of

TABLE 2

	A Ungrounded	B Effectively Grounded	C Reactance Grounded	D Resistance Grounded	E Resonant Grounded
(1) Apparatus Insulation	Fully Insulated	Lowest	Partially Graded	Partially Graded	Partially Graded
(2) Fault to Ground Current	Usually Low	Maximum value rarely higher than three-phase short circuit current	Cannot satisfactorily be reduced below one-half or one-third of values for solid grounding	Low	Negligible except when Petersen coil is short circuited for relay purposes when it may compare with solidly-grounded systems
(3) Safety from voltage gradient considerations	Usually good, but not fully dependable because of possibility of simultaneous fault on another phase	Gives greatest gradients, but not usually a problem where continuous ground wires are used.	Slightly better than effective grounding.	Better than effective or reactance grounded.	Least gradient normally, but may approach effective grounding values when necessary to shunt ground fault neutralizer to isolate faulty circuit by re-laying.
(4) Stability	Usually unimportant	Lower than with other methods but can be made satisfactory by use of high speed relays and circuit breakers	Improved over solid grounding particularly if used at receiving end of system	Improved over effective grounding particularly if used at sending end of system	Is eliminated from consideration during single line-to-ground faults unless neutralizer is short circuited to isolate fault by relays
(5) Relaying	Difficult	Satisfactory	Satisfactory	Satisfactory	Requires special provisions but can be made satisfactory
(6) Arcing Grounds	Likely	Unlikely	Possible if reactance is excessive	Unlikely	Unlikely
(7) Localizing Faults	Effect of fault transmitted as excess voltage on sound phases to all parts of conductively connected network	Effect of faults localized to system or part of system where they occur	Effect of faults localized to system or part of system where they occur unless reactance is quite high	Effect of faults transmitted as excess voltage on sound phases to all parts of conductively connected network	Effect of faults transmitted as excess voltage on sound phases to all parts of conductively connected network
(8) Double Faults	Likely	Unlikely	Unlikely unless reactance is quite high and insulation weak	Unlikely unless resistance is quite high and insulation weak	Seem to be more likely but conclusive information not available
(9) Lightning Protection	Ungrounded neutral service arresters must be applied at sacrifice in cost and efficiency	Highest efficiency and lowest cost	If reactance is very high arresters for ungrounded neutral service must be applied at sacrifice in cost and efficiency	Arresters for ungrounded, neutral service usually must be applied at sacrifice in cost and efficiency	Ungrounded neutral service arresters must be applied at sacrifice in cost and efficiency
(10) Inductive Coordination	Will usually be low except in cases of double faults or electrostatic induction with neutral displaced but duration may be great	Will be greatest in magnitude due to higher fault currents but can be quickly cleared particularly with high speed breakers	Will be reduced from solidly grounded values	Will be reduced from solidly grounded values	Will be low in magnitude except in cases of double faults or series resonance at harmonic frequencies, but duration may be great
(11) Radio Influence	May be quite high during faults or when neutral is displaced	Minimum	Greater than for solidly grounded, when faults occur	Greater than for solidly grounded, when faults occur	May be high during faults

TABLE 2—Continued on Next Page

TABLE 2—CONTINUED

	A Ungrounded	B Effectively Grounded	C Reactance Grounded	D Resistance Grounded	E Resonant Grounded
(12) Line Availability	Will inherently clear themselves if total length of interconnected line is low and require isolation from system in increasing percentages as length becomes greater	Must be isolated for each fault	Must be isolated for each fault	Must be isolated for each fault	Need not be isolated but will inherently clear itself in about 60 to 80 percent of faults
(13) Adaptability to Interconnection	Cannot be interconnected unless interconnecting system is ungrounded or isolating transformers are used	Satisfactory indefinitely with reactance-grounded systems	Satisfactory indefinitely with solidly-grounded systems	Satisfactory with solidly- or reactance-grounded systems with proper attention to relaying	Cannot be interconnected unless interconnecting system is resonant grounded or isolating transformers are used. Requires coordination between interconnected systems in neutralizer settings
(14) Circuit Breakers	Interrupting capacity determined by three-phase fault conditions	Same interrupting capacity as required for three-phase short circuit will practically always be satisfactory	Interrupting capacity determined by three-phase fault conditions	Interrupting capacity determined by three-phase fault conditions	Interrupting capacity determined by three-phase fault conditions
(15) Operating Procedure	Ordinarily simple but possibility of double faults introduces complication in times of trouble	Simple	Simple	Simple	Taps on neutralizers must be changed when major system switching is performed and difficulty may arise in interconnected systems. Difficult to tell where faults are located
(16) Total Cost	High, unless conditions are such that arc tends to extinguish itself, when duplicate circuits may be eliminated, reducing total cost	Lowest	Intermediate	Intermediate	Highest unless the arc suppressing characteristic is relied on to eliminate duplicate circuits when it may be lowest for the particular type of service

probability, but completely satisfactory results probably cannot be secured above 100 miles of 11-kv circuits or 25 miles of 69-kv circuits. On total circuit lengths of this order or lower the ungrounded-neutral systems will probably have fewer trippouts than any form of grounded system, and, where feeds are essentially single-circuit radial, better service to customers can be rendered.

Lightning arresters must be applied on the basis of full line-to-line voltage, which increases the expense of protection and somewhat reduces their effectiveness. Selective relaying on ground faults is practically impossible for these short line lengths so that the detection and isolation of faulty lines is likely to be quite long. In some instances, for example with a line down, this circumstance may present a hazard to life. If the circuits are long enough to

give sufficient fault current for relaying, then the self-clearing advantage is lost and the system might as well be grounded in some manner.

The ungrounded-neutral system is not likely to cause high voltages to be induced in neighboring communication circuits because the ground-fault currents are ordinarily low. However, on early designs or lines in a poor state of maintenance, this is not necessarily so, as the full displacement of neutral accompanying a ground fault on one phase is conducive to producing a fault on one of the other phases, thus producing a double fault with earth currents comparable with systems of solidly grounded neutral. Furthermore, the influence on communication systems is not alone a matter of current magnitude; it also involves duration and wave form of the earth current. Because of

the absence of or ineffectiveness of ground relaying on ungrounded systems, such faults will persist for some time. Also, the arcing condition with the capacitance current is productive of badly distorted wave forms, throwing a good part of the energy into the higher frequencies where the influence is greater. In several instances it has actually been found true in practice that inductive influence has been decreased following adoption of some form of grounding. As a general statement therefore, ungrounded operation cannot be considered superior to grounded operation from the inductive influence point of view.

While it is likely that the destructive effects of "arcing grounds" has been exaggerated in the past, all of the accumulated opinion in this regard cannot be discarded. More recent studies (See Chap. 14) also bear out the higher "switching surges" existent on ungrounded-neutral systems. It therefore seems necessary to assume that an ungrounded-neutral system will result in more equipment damages and "unaccounted for" interruptions than some form of grounded system. Transformers must be designed on the basis of full neutral displacement and in the higher voltage classes this will result in a somewhat higher cost.

7. Resistance-Grounded Systems

Grounding through resistance immediately disposes of two defects of the ungrounded system: it permits ready relaying of ground faults and it minimizes the hazard of arcing grounds.

In general the grounding resistances used have limited the ground-fault current to a magnitude much less than the three-phase short-circuit current. This is almost imperative in order to limit the power loss in the grounding resistor to a reasonable figure as discussed in Sec. 2. However, the result is that the system neutral will almost invariably be fully displaced in case of a ground fault, thereby necessitating the use of full-rated lightning arresters at an increase in cost and sacrifice in protective performance. The latter is not particularly a handicap with modern arresters and modern transformers, but it may be important with older transformers having materially lower impulse strength.

In certain instances, the use of grounding resistances may improve the stability of a power system during ground faults by replacing the power dropped, as a result of low voltage, with an approximately equal power loss in the resistor, thus reducing the advance in phase of the generators. This scheme was used on the 15-Mile Falls development of the New England Power Company.

In general, a resistance-grounded system will have materially lower ground-fault current than a solidly grounded system and hence will have less inductive influence on paralleling communication circuits. In some instances this may be of considerable practical importance.

On systems of lower voltage, say up to and including 46 kv, ground relaying may play an important part in the selection of a grounding procedure. Consider, for example, the 22-kv system of Fig. 11 where the three-phase short-circuit current at station A is 12 500 amperes and the line-to-ground fault current with zero-fault resistance is 9700 amperes. The zero-sequence voltage at station A, if calculated will be found to be about 48% of normal phase to

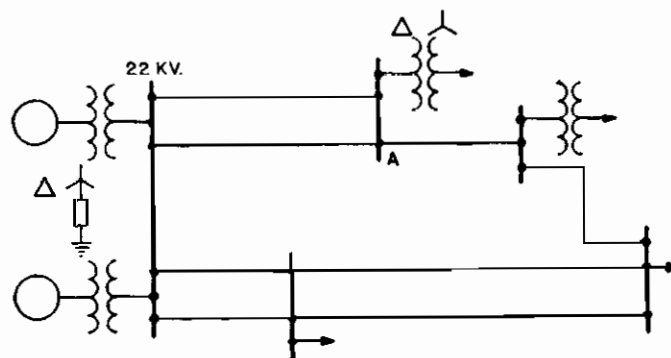

Fig. 11—Low- or medium-voltage looped transmission system with single grounding point presents difficulties in relaying ground faults unless a neutral grounding resistor is employed.

neutral voltage. If a ground fault having a resistance of 10 ohms occurs, the fault current will be reduced to 1320 amperes, and the zero-sequence voltage to about 6.5 percent of the normal phase-to-neutral value. This voltage is insufficient for dependable directional ground relaying if fault resistances of 10 ohms and upward are encountered, as they ordinarily will be unless the lines are on steel towers, and connecting ground wires are used. In cases like this, impedance, preferably resistance, in the neutral is necessary for satisfactory relaying. On a smaller system, where the maximum short-circuit current is much less than the example given, there may always be sufficient residual voltage without the necessity of a neutral-impedance device. Furthermore, on simple radial systems where zero-sequence voltage is not required for polarizing of directional relays, this factor need not be considered.

A typical stainless steel grounding resistor is shown in Fig. 12.

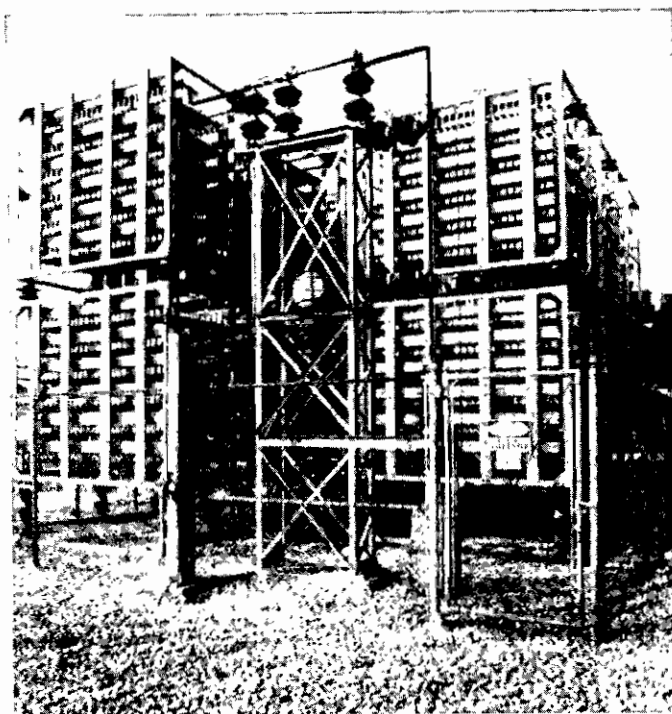

Fig. 12—30-ohm stainless steel grounding resistor.

8. Effectively Grounded Systems

In all voltage classes, effectively grounded systems are less expensive than any other type of grounding. This is because "arresters for solidly grounded neutral service" can be applied, and because no auxiliary grounding devices in the form of resistors, reactors, neutralizers, etc., are ordinarily required. This statement implies either a new system, or an addition to a system. It may also apply to an existing system if sufficient star-connected apparatus is available. On a system where only delta-connected transformers are available, any form of grounding of the existing system will involve extra expense. On systems 115 kv and above, additional savings are available because transformers for solidly grounded neutral service can be purchased, with the insulation graded toward the neutral end, at less cost.

On an effectively grounded system all faults including grounds must be cleared by opening the line. (This is also true of resistance- and reactance-grounded systems, and partly on ungrounded- and neutralized-grounded systems.) Close to the grounding points, the ground-fault currents are high, in some cases exceeding the three-phase short-circuit currents. In a few instances higher interrupting capacity breakers may be required over that necessary for three-phase short-circuit interruption. The higher currents also produce more conductor burning. The greater currents result in lower positive-sequence voltages with a tendency toward a lower stability limit for line-to-ground faults. The higher earth currents may in some cases interfere with communication circuits.

Most unfavorable influences from the above high-current phenomena have largely been removed, so far as system extensions are concerned, by the availability of the newer high-speed relays and circuit breakers. These comments apply particularly to such items as stability, conductor burning and communication circuit influence. The interrupting requirements of circuit breakers can be brought to equality with that for the three-phase fault condition by the addition of a moderate-sized grounding reactor where necessary. When the reduction in current is no more than this, the system will still retain the classification of "effectively grounded," although the transformers grounded through reactance will require greater neutral insulation, but will not necessarily be fully insulated.

On grounded neutral systems, it is usual for the transformers in generating stations, to be connected delta on the generator side and grounded star on the high voltage side. Practice varies with regard to step-down transformers, some being connected star and others delta on the high voltage side. The latter is perhaps the more usual, particularly if the secondary transmission or distribution circuits are also grounded neutral. Systems laid out in this manner are in some instances subject to abnormally high voltages in the event of single conductor breaks in the line. The same comment may be made with regard to fusing and single pole switching. The circumstances required to produce these abnormal voltages rarely occur, but the phenomena warrants consideration. See reference 10.

9. Reactance-Grounded Systems

Reactance-grounding falls somewhere between effective grounding and resonant grounding. In the lack of an ac-

cepted standard, the criterion will here be taken in terms of the ratio, $\frac{X_0}{X_1}$. A ratio of more than three requires the use of full-rated arresters, so the range between this point and the reactance for ground-fault neutralizers should logically be considered as reactance grounded.

At points on the system where $X_0/X_1=3$ or less, the ground-fault currents will be of the same order as those on effectively grounded systems, and the same comments as for effective grounding will apply except that the transformer insulation may need to be graded at the neutral end, if a neutral reactor is used.

For neutral reactances, the ground-fault currents decrease and the neutral displacements increase. The transient overvoltages resulting from arcing increase as the reactance is increased, up to a reactance of about $\frac{1}{3}$ that required for ground-fault neutralizing, beyond which point they again decrease, reaching another minimum at the tuned reactance. Further increases in reactance again result in higher voltages. During switching operations the indications are that the higher the reactance, the higher the surge voltage to be expected. See Fig. 36 in Chap. 14.

The general indication is that there is no merit in purposely increasing the grounding reactance of a system beyond that required to keep currents within nondestructive range, except of course, for the special case of ground-fault neutralizers. Systems grounded through high-reactance are uncommon except where delta-connected ungrounded systems have been grounded by means of ground-

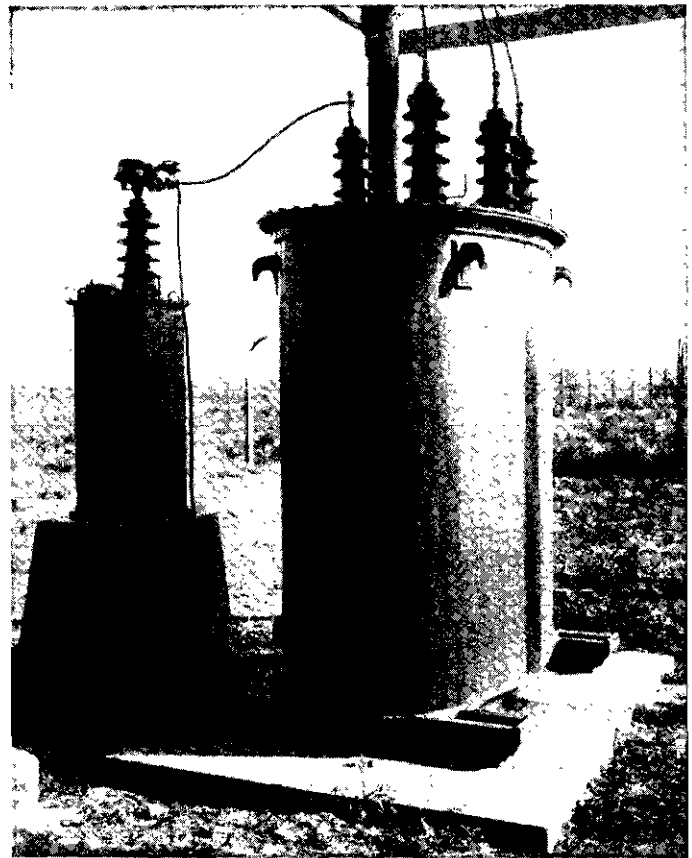

Fig. 13—Typical grounding transformer.

ing transformers. Here, the element of expense has frequently caused small grounding transformers to be used, the principal object usually being to secure enough ground current for relaying.

Grounding transformers are usually wound "zig-zag" for economy. For temporary jobs, or where idle transformers are available, conventional star-delta transformers are sometimes used. When this is done, care must be exercised that the transformers are not burned out by excessive fault duration, as the current through the transformers during ground faults will usually be nearly the full short-circuit value. A typical grounding transformer is shown in Fig. 13.

10. Resonant-Grounded Systems

When a system is equipped with ground-fault neutralizers, the neutral is displaced over all parts conductively tied together when a ground fault occurs. This means that two phases are at full line-to-line voltage above ground. Full-rated lightning arresters are therefore required. All line switching must be coordinated centrally in order to determine the proper neutralizer taps. Interconnected systems must be included in this coordination, or else isolated by two-winding transformer banks. An alternative zero-sequence isolating device is shown in Fig. 14. The principle of operation is that for three-phase currents whose sum total is zero, the device presents only the leakage reactance of the windings whereas for zero-sequence currents flowing in the same direction in each winding, only the high magnetizing impedance is effective.

In general, the use of ground-fault neutralizers will decrease the number of line interruptions from ground faults to 20 or 30 percent of those obtainable with some form of

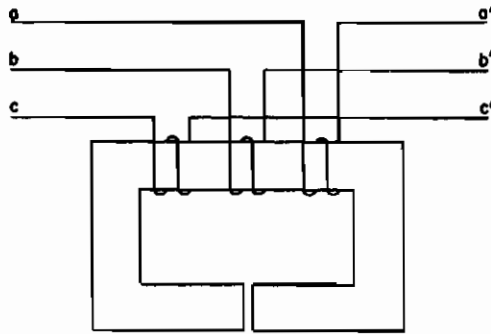

Fig. 14—Zero-sequence isolator. The positive- and negative-sequence reactance between *a*, *b*, *c* and *a'*, *b'*, and *c'* are low, but the zero-sequence reactance is high.

grounded operation. Complete effectiveness cannot be attained, because some faults will be caused by physical line damage and a proportion will fail to clear as a result of other causes, such as improper tuning. Interruptions caused by initial involvement of more than one phase are practically unchanged but the tendency of a single-phase ground fault developing into a two- or three-phase fault will be decreased. Ground relays must be retained to clear those ground faults not extinguished by neutralizer action. They are brought into play after a predetermined duration of ground-fault current by short-circuiting the neutral-

reactance device. A typical connection diagram is shown in Fig. 15.

The value of ground fault neutralizers to a system depends upon its type and construction. If the system is predominantly of multi-circuit or loop-feed construction, the principal advantages are those resulting from small

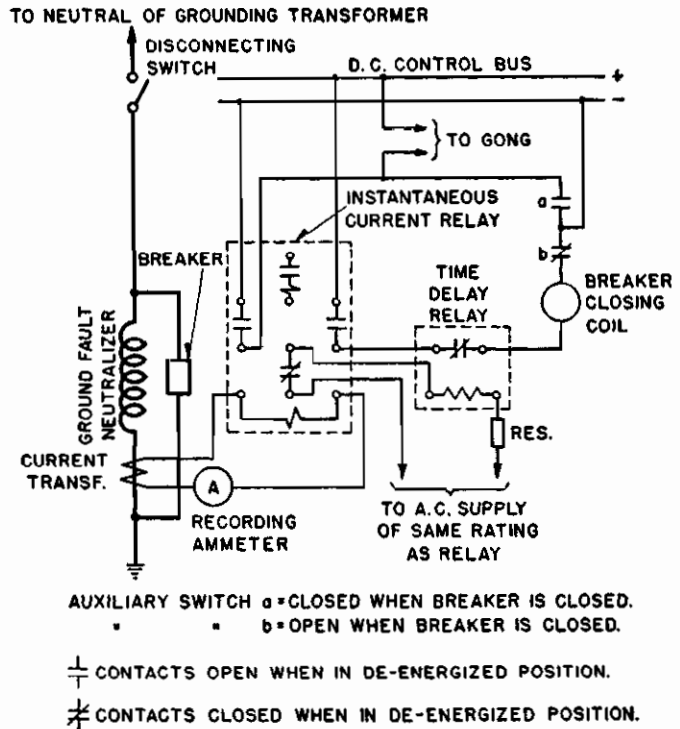

Fig. 15—Method of short-circuiting ground fault neutralizer after predetermined duration of ground-fault current.

ground currents—less likelihood of communication-circuit interference, conductor burning and light flicker. In individual cases these favorable influences may be of value. If the lines are predominantly of wood-pole construction with high insulation to ground, a greater proportion of the faults will be line-to-line and the neutralizer will therefore not be so effective.

On systems having a large proportion of single-circuit radial lines the value of neutralizers may be considerable. In addition to the items mentioned above is the fact that a large proportion of ground faults will be cleared without line interruption. With radial feeds this is important, as it may avoid construction of paralleling lines for service continuity alone, and thus be productive of considerable capital savings.

Ground-fault neutralizers cannot be used on systems where fully graded insulation transformers are in service, as these neutrals are not sufficiently well insulated. If line sectionalizing switches are used, they should be gang operated. Fuses should not be used in series with any appreciable length of line. Ground-fault neutralizers should not be used on systems employing auto-transformers having a greater ratio than 0.95 to 1.00.

Ten-minute time-rated ground-fault neutralizers are used on systems on which permanent ground faults can be located and removed promptly either by ground relays

or other suitable means. Continuous time-rated ground-fault neutralizers are used on all other systems.

No general rule on the number of neutralizers to use in a given application can be stated. A neutralizer in each section of the system that may become sectionalized during disturbances will give the utmost in protection and simplicity of operation. The increased flexibility of operation must be weighed against the increased cost for the larger number of neutralizers in making the final decision on what is to be undertaken.

Occasionally a situation arises wherein it is desired to use a ground-fault neutralizer in conjunction with a three-winding star-delta-star transformer bank. If the neutralizer is connected between one neutral point and ground, and the other neutral point is solidly grounded, serious overvoltages on the neutralizer grounded system may ensue, when a ground fault occurs on the solidly-grounded side of the transformer bank.

Figure 16 illustrates in (a) the system connection, and in (b) the equivalent zero-sequence impedance diagram.

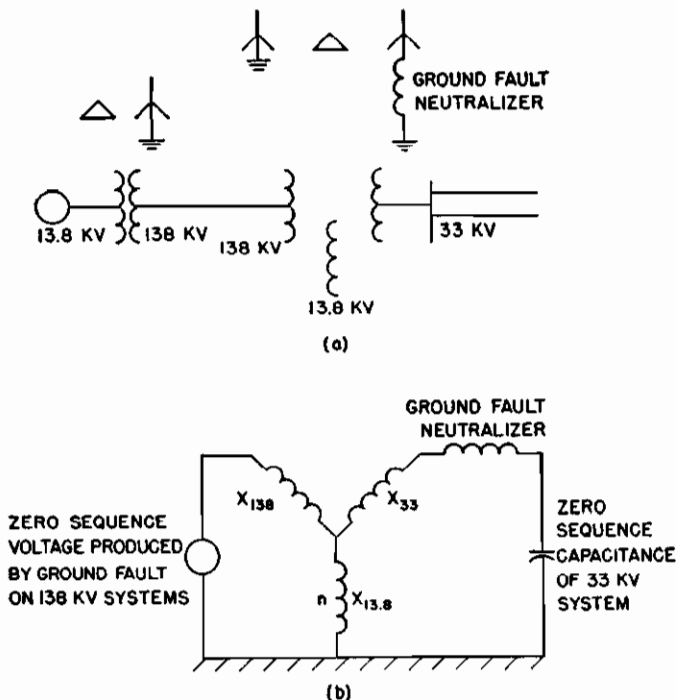

Fig. 16—(a) Hypothetical system using ground fault neutralizer with three-winding transformer.
(b) Zero sequence impedance diagram applying to (a).

In the latter, it will be noted that branch n of the transformer equivalent circuit is common to both star connected circuits. A ground fault on the grounded neutral side therefore causes a zero-sequence voltage to be applied to the neutralized system. The neutralizer inductive reactance and system zero sequence capacitance are in series relationship to this voltage. Series resonance therefore occurs, and due to the high X/R ratio of neutralizers, the applied voltage may be amplified ten or more times.

When it is known that such usage is contemplated at the time of purchase of the transformer bank, it may be possible to design it so that branch n has zero impedance. Gen-

erally, this is quite expensive. An alternative procedure is to induce an equal and opposite voltage in the neutralized system by means of reactors fed from current transformers in the delta windings. This entails much engineering study and adjustments when placing in operation. Generally, the best procedure is to avoid the condition by not grounding the other neutral point, and seeking other locations for grounding the system.

11. General Summary on Transmission System Grounding

The preceding discussion brings out that the various methods of grounding have their peculiar advantages and disadvantages so that individual circumstances can be expected to decide the issue. Nevertheless, a few combinations of conditions cover the great majority of systems, and some generalization is possible for these combinations.

In the vicinity of our larger cities and in industrialized areas, continuity of service is regarded as of such importance that multiple circuit lines and two direction feeds are the rule. On such systems a momentary line tripout does not interrupt service, because additional circuits are available for the worse eventuality of physical damage to a line. These lines are usually relayed to clear a fault in from 0.15 to 0.5 seconds. They are usually tied in conductively with lines of the same voltage operated by contiguous companies. There is a large amount of equipment tied to these lines, and lightning protection and confinement of trouble to a small area is desirable. For systems of this character, effective grounding appears to be the best practice. At some locations, ground fault current limitation may be necessary from the standpoint of circuit breaker interrupting duty or inductive effects, but this can probably be accomplished without exceeding a zero sequence ratio of three, thus permitting application of "lightning arresters for grounded neutral service."

In less densely populated regions, the relation between loads and transmission distances is frequently such that only single-circuit lines are justified. Systems of this type are good fields for the application of ground-fault neutralizers. The number of interruptions can be greatly reduced at moderate cost by such means. While full-rated lightning arresters and transformers are required, the spacing of substations will usually be large enough that this does not unduly increase the cost. Where only a few lines are single-circuit radial, improvement of these lines by "lightning proofing" or the application of lightning protector tubes may be the most economical solution.

In some instances of long-distance power transmission, the overall cost can be decreased by using one transmission circuit at a high voltage rather than two or more circuits at a lower voltage. Where other power sources are available when the line is out for maintenance or repair, the use of the single-circuit line with ground-fault neutralizers becomes a feasible way of limiting the total investment. This method should be compared in cost and other features with the use of high-speed reclosing breakers.

The question of the number of grounding points is frequently asked. On systems in the effectively grounded class, there is no reason why all available neutrals should not be grounded, so long as the ground-fault current does

not require the application of breakers having larger interrupting capacity. On resistance- or reactance-grounded systems, or with ground-fault neutralizers, each additional grounding point increases the total cost. In these cases, the number of grounding points will largely be dictated by the ability to secure satisfactory ground relaying. On other than radial systems, at least two and preferably more grounding points are desirable to get most satisfactory directional ground relaying.

Grounding practice should be considered in the light of improvement in other branches of central-station work. Relays and breakers have been improved so that they will clear both phase and ground faults with a reliability and speed greatly exceeding those obtainable a few years ago. Complaints from flicker, and unnecessary operation of low-voltage releases are correspondingly fewer. Automatic high-speed reclosing is available for transmission service and affords a means of avoiding outages from momentary causes from both phase and ground faults. Lightning proofing of transmission lines is markedly effective in reducing the total number of flashovers. In most instances these factors will indicate a preference for the effectively grounded system. A chart showing a comparison between the various ground procedures is given in Table 2.

12. Trends and Practices in Transmission System Grounding

Figures 17 and 18 are plotted from data obtained from the Third AIEE Report on System Grounding.¹² The data used in that report was collected by questionnaires, and according to the definitions used, "solid" means that no extra impedance is inserted between apparatus neutral points and ground. "Reactance" grounded means that in some instance, neutral reactors are used on an otherwise solidly-grounded system; in other instances, it means the

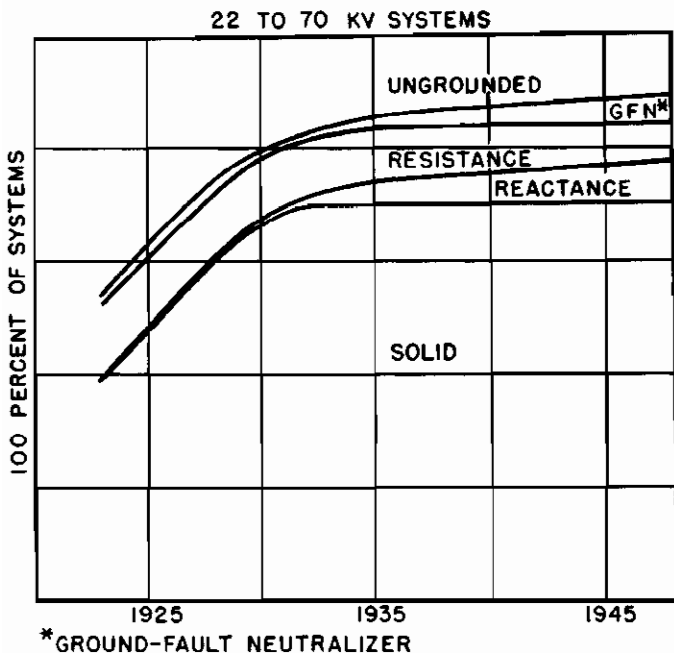

Fig. 17—Relative United States use of grounding methods on transmission and distribution systems in the voltage range of 22 to 70 kv.

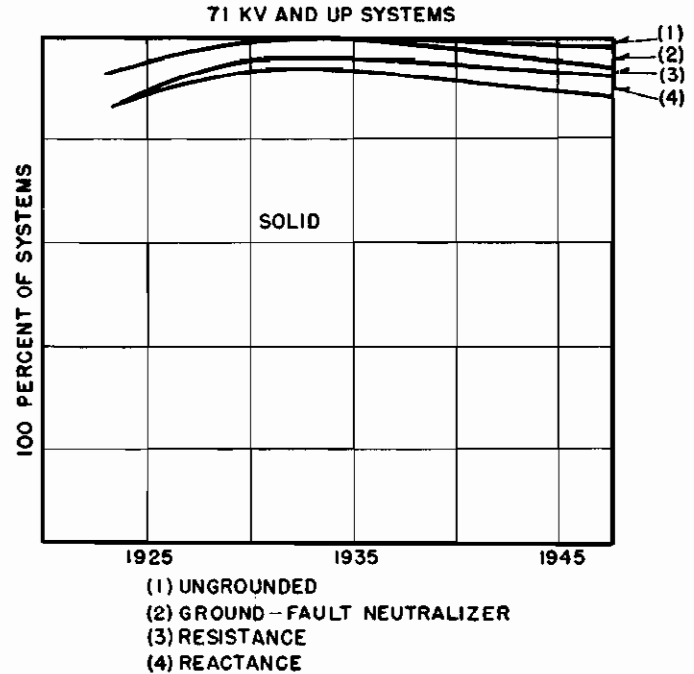

Fig. 18—Relative United States use of grounding methods on transmission systems from 71 kv up.

use of grounding transformers. In the majority of cases, "solid" grounding means that the systems are effectively grounded (X_0/X_1 is three or less). Likewise, many of the "reactance" grounded systems are effectively grounded. For purpose of classification, a system is still considered "ungrounded", if the only ground is through potential transformers.

Figure 17 shows the relative use of grounding methods on transmission and distribution systems in the voltage range of 22 to 70 kv. There has been a steady decrease in the ungrounded category, and an approximately like increase in solid grounding. Ground-fault neutralizers are being used to an increasing extent, although still a small portion of the total. Their use in the United States is still largely confined to single-circuit lines serving large areas.

Figure 18 is for systems 71 kv and up. These curves show the dominant use of effective or solid grounding in the United States. The majority of "reactance grounded" systems are effectively grounded.

III. FUNDAMENTAL PRINCIPLES OF GENERATOR GROUNDING

There are even more ramifications of generator grounding than for transmission-system grounding. The many possible combinations of connections between generators and outgoing lines is responsible for this. The more common connections in use in generating stations are shown in Figs. 19 to 23.

The so-called unit system, Fig. 19 is one in which each generator is directly connected to its individual transformer bank, the low-voltage side being delta, and the high-voltage side, star. So far as ground currents are concerned the machines are isolated from one another

and the high-voltage system. A variation of this arrangement is sometimes used where two generators supply a common transformer bank. An arrangement using both high- and low-voltage buses is given in Fig. 20. The individual machines are therefore tied, insofar as the flow of ground current is concerned. Fig. 21 is for power

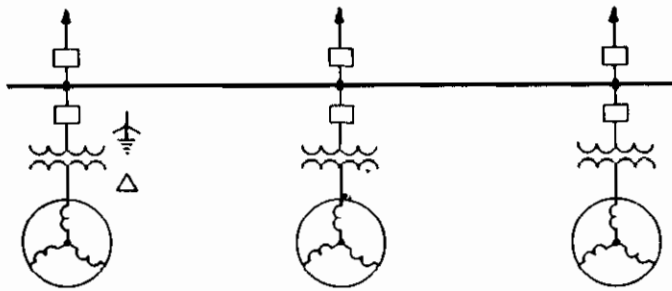

Fig. 19—Unit system—power transmitted at high voltage.

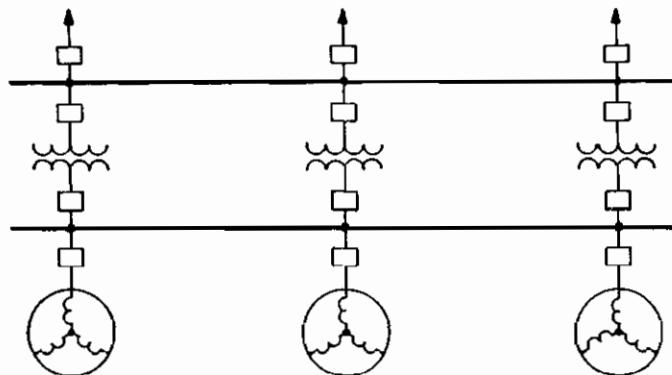

Fig. 20—High- and low-voltage bus system—power transmitted at high voltage.

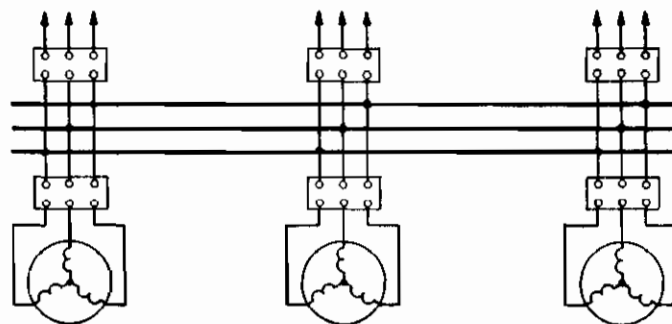

Fig. 21—Power transmitted at generator voltage—three-wire system.

distribution over a three-wire system at generator voltage. Fig. 22 is the same as Fig. 21 except the distribution system is four-wire. A system where the generator voltage is doubled or increased by $\sqrt{3}$ by auto-transformers for distribution is shown in Fig. 23.

In general the unit scheme of Fig. 19 gives the greatest freedom in the selection of a grounding procedure, while the other schemes place various restrictions on the choice.

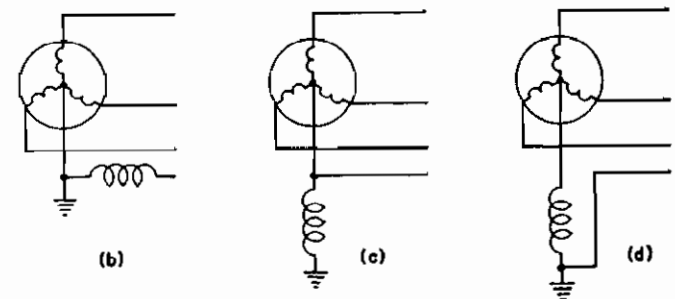
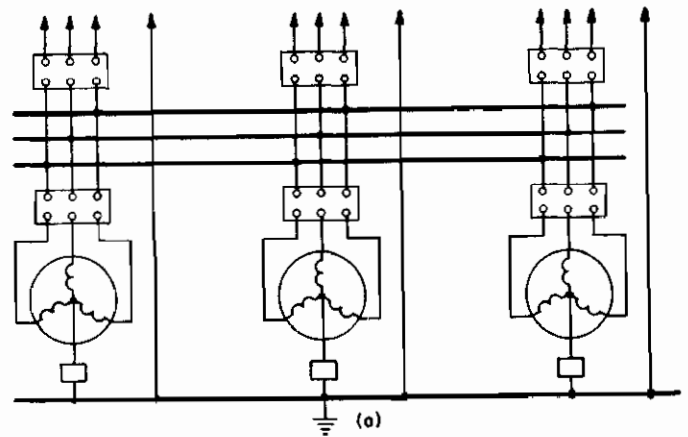

Fig. 22—Power transmitted at generator voltage—four-wire system.

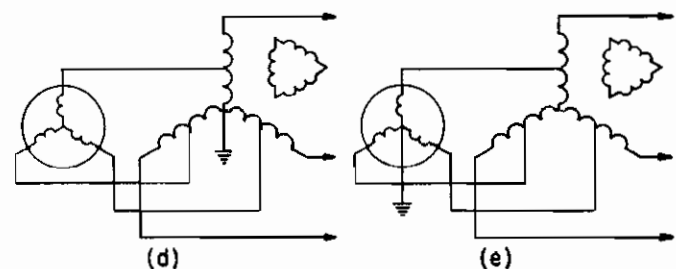
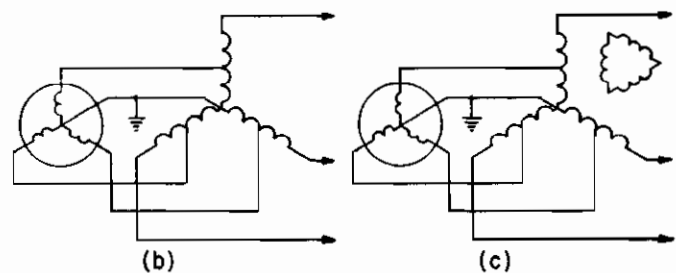
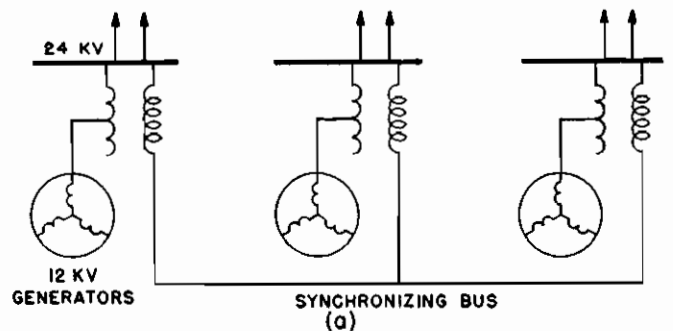

Fig. 23—Power transmitted at double generator voltage by auto-transformers.

13. Ground Currents

The ground-fault current for one phase of a three-phase system is given by the expression

$$I_F = (I_0 + I_1 + I_2) = \frac{3E_g}{Z_0 + Z_1 + Z_2}$$

If a generator is operating as an isolated machine, the current so calculated will be the current through the faulted phase. If Z_0 is less than Z_1 or Z_2 as is commonly the case, the ground-fault current will be greater than the three-phase fault current $\frac{E_g}{Z_1}$. If several machines

are operated in parallel, and only one machine grounded, this effect is accentuated in the grounded machine.

For example, consider four generators operating in parallel as shown in Fig. 24 (a). The reactances shown are in percent based on the individual machine ratings.

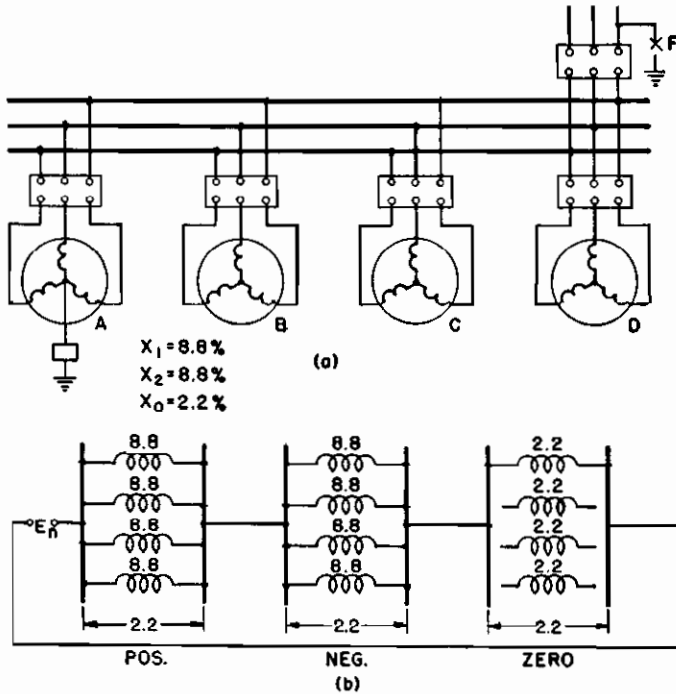

Fig. 24—Single line-to-ground fault on four generators operating in parallel with only one machine grounded.

The phase-sequence-reactance diagram is shown by Fig. 24 (b) from which $Z_0 = 2.2$; $Z_1 = 2.2$ and $Z_2 = 2.2$.

The sequence components for a line-to-ground fault are

$$I_0 = I_1 = I_2 = \frac{100}{2.2 + 2.2 + 2.2} = 15.2$$

times full-load current of one generator. The total fault current $= I_0 + I_1 + I_2 = 45.6$ times full load of one generator.

The components of fault current through the grounded generator are:

$$I_{a0} = I_0 = 15.2 \text{ times full load.}$$

$$I_{a1} = \frac{1}{4} I_1 = 3.8 \text{ times full load.}$$

$$I_{a2} = \frac{1}{4} I_2 = 3.8 \text{ times full load.}$$

The fault current through the faulted phase of the grounded generator $= I_{a0} + I_{a1} + I_{a2} = 22.8$ times full load.

The three-phase fault current of an individual generator is $\frac{E_g}{X_1} = \frac{100}{8.8} = 11.4$ times full load. Consequently, in the case illustrated, grounding only one generator will cause that generator to carry $\frac{22.8}{11.4}$ or twice the current it would

have on a three-phase fault. Since mechanical stresses are proportional to the square of the current, they would be equal to four times the three-phase short-circuit stresses.

The effect of different numbers of machines operating in parallel, with all neutrals grounded, and with only one machine grounded is illustrated in Fig. 25. These curves were computed on the basis of $X_1 = X_2 = 8.8$ percent and $X_0 = 2.2$ percent, and for the machines paralleled directly at their terminals. It will be observed that the line-to-ground fault current is always greater than the three-phase fault current, and that the situation becomes par-

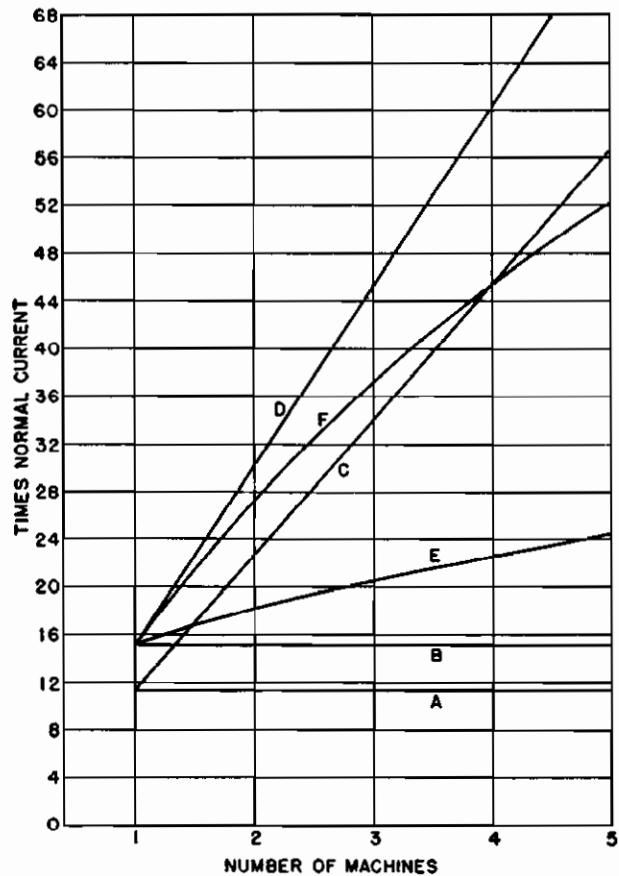

Fig. 25—Total fault and machine currents for single line-to-ground and three-phase faults.

- A—Current in any machine—three-phase fault.
- B—Current in one machine—single line-to-ground fault with all machines grounded.
- C—Total current—three-phase fault.
- D—Total current—single line-to-ground fault with all machines grounded.
- E—Current in grounded machine—single line-to-ground fault with only one machine grounded.
- F—Total current—single line-to-ground fault with only one machine grounded.

ticularly serious as the number of paralleled machines increases. In an installation of this kind, some form of neutral impedance device is a necessity.

In order to determine the size of neutral reactor to limit the generator winding current for a single line-to-ground fault to the generator winding current on a three-phase fault the constants of the generator and the constants of the system must be known. The system constants must include all circuits and sources of supply to the fault except the machine under consideration. Five groups of formulas are listed below for single line-to-ground faults depending upon the reactance values. Group 1 is perfectly general and the other groups are simplified.

e = percent generated voltage

X_R = percent reactance of neutral reactor on generator kva base

I_R = percent reactor current based on normal generator current

	Generator	System
Pos. seq. reactance on gen. kva	X_1	S_1
Neg. seq. reactance on gen. kva	X_2	S_2
Zero seq. reactance on gen. kva	X_0	S_0

Group 1. All reactance values finite and different. $X_R = \frac{S_0(X_1X_2 + 2X_1S_2 - X_2S_2) + X_0(X_1S_2 - X_2S_2 - X_2S_0 - S_0S_2)}{3(X_2S_0 + X_2S_2 - X_1S_2 + S_0S_2)}$

$$I_R = \frac{300eS_0}{(X_0 + S_0 + 3X_R) \left(\frac{X_1S_1}{X_1 + S_1} + \frac{X_2S_2}{X_2 + S_2} + \frac{S_0(X_0 + 3X_R)}{X_0 + S_0 + 3X_R} \right)}$$

Group 2. $S_0 = \text{infinite}$; others finite and different. $X_R = \frac{X_1 - X_0 + S_2(X_1 - X_2)}{3} + \frac{S_2(X_1 - X_2)}{3(X_2 + S_2)}$; $I_R = \frac{300e}{\frac{X_1S_1}{X_1 + S_1} + \frac{X_2S_2}{X_2 + S_2} + X_0 + 3X_R}$

Group 3. $X_1 = X_2$; others finite and different. $X_R = \frac{X_1 - X_0}{3}$; $I_R = \frac{300eS_0}{X_1(X_1 + S_0)} \left(\frac{1}{\frac{S_1}{X_1 + S_1} + \frac{S_2}{X_1 + S_2} + \frac{S_0}{X_1 + S_0}} \right)$

Group 4. $X_1 = X_2$; $S_0 = \text{infinite}$; others finite and different, $X_R = \frac{X_1 - X_0}{3}$; $I_R = \frac{300e}{X_1} \left(\frac{1}{\frac{S_1}{X_1 + S_1} + \frac{S_2}{X_1 + S_2} + 1} \right)$

Group 5. $X_1 = X_2$; $S_1 = S_2$; $X_0 = \text{finite}$; $S_0 = \text{infinite}$, $X_R = \frac{X_1 - X_0}{3}$; $I_R = \frac{300e}{X_1} \left(\frac{X_1 + S_1}{X_1 + 3S_1} \right)$

14. Neutral Displacement

When a ground fault occurs, there is a tendency for a neutral shift with consequent change in voltage on the unfaulted phases. The phenomenon is the same as discussed in Part I; and Fig. 6, Chap. 14, can be used to determine the voltage to which apparatus on the unfaulted phases will be subjected.

15. Circulating Harmonic Currents

When two generators are operated in parallel at generated voltage as in Fig. 26, there is the possibility of cir-

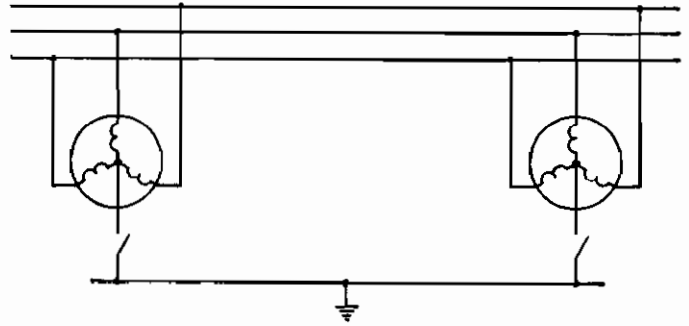

Fig. 26—Two generators operating in parallel at generated voltage.

culating harmonic currents. This is true whether the neutrals are interconnected or not. The two conditions necessary for the flow of harmonic current are: the presence of a resultant harmonic voltage, and a path for the flow of current. It is important to note the term "resultant." If the two machines are duplicates and are being operated under identical conditions, they will probably generate the same harmonics of about the same magnitude and phase position. If the harmonics are thus equal and opposite, there will be no resultant voltage available to circulate harmonic current. If, however, the machines are dissimilar, one may generate harmonic voltages that the other does not. There will then be a circulating harmonic current between them whose magnitude is equal to the resultant harmonic voltage divided by the impedance at the harmonic frequency. For line-to-line harmonics the latter is approximately equal to the negative-sequence reactance in ohms at rated frequency times the order of the harmonic. For two machines as illustrated, the resultant reactance would be the sum of the harmonic reactances of the two machines, as they are in series for harmonic-current flow. If more than two machines are in parallel, but only one generating a high-harmonic voltage, the harmonic reactance of the one machine is added in series with the paralleled reactance of the remaining generators. If all machines are generating considerable harmonic voltage, an analysis is almost impossible because slight shifts in fundamental frequency phase position with load will greatly alter the resultant harmonic voltages.

The situation with respect to neutral harmonics is much similar to that for line harmonics except that only triple series harmonics, 3rd, 9th, 15th, 21st, etc., can flow in the neutral. This is because the 120 degree relationship of phases causes all other harmonics to be balanced and thus total to zero in the three phases. Also the zero sequence impedances apply rather than the negative sequence. Referring again to Fig. 26, it is apparent that neutral circulating harmonic currents cannot flow unless both neutral circuit breakers are closed. Then, if there is a resultant zero-sequence harmonic voltage, a current will flow equal to the voltage divided by the zero-sequence reactance at the harmonic frequency.

The harmonic currents circulating in the neutral are likely to be somewhat higher in magnitude than the line-to-line harmonic currents. This is because the third harmonic voltage is usually higher than any other and be-

cause the zero-sequence reactance is usually lower than the negative-sequence reactance. In the case of two-thirds pitch machines, the triple series (neutral) harmonics will be practically zero, so that it will not create harmonic currents. On the other hand, the zero-sequence reactance of a two-thirds pitch machine is quite low so that it is a likely path for the flow of triple harmonics generated by other machines.

Circulating harmonic currents between apparatus in a station are not particularly objectionable unless unusually large. A circulating neutral harmonic current of 30% would offhand appear to be of an order to be injurious to a machine. However, this means only 10 percent harmonic current per phase. The rms value in combination with full-load current would be $\sqrt{100^2 + 10^2} = 100.5$ percent. The heating effect will be somewhat greater than this, but probably not more than another $\frac{1}{2}$ percent so that the loss of load-carrying capacity is inappreciable.

16. Communication-Circuit Influence

Where generator neutrals are grounded and distribution is done at generated voltage, whatever residual harmonics are present in the generator wave form are impressed on the lines. Residual harmonics are more likely to cause inductive effects in nearby communication circuits than line-to-line harmonics because the return circuit is through the earth at a considerable depth. When the distribution circuits are in underground cables the likelihood of inductive effects is small. On overhead lines, however, consideration should be given to this question.

17. Surge Protection

This question is covered in detail in Chap. 18. It is related to grounding methods in that "grounded neutral service" arresters can be applied if the system is effectively grounded, whereas arresters rated at maximum line-to-line voltage are necessary if the system is not effectively grounded.

Because of space limitations and costs, it is not practical to insulate generators to the same impulse levels as oil-insulated apparatus of the same voltage class. Therefore, the protection margin is decreased for ungrounded, resistance-grounded and high-reactance-grounded generators. This situation has been helped to a degree by the use of "rotating machine" arresters. The experience so far indicates that full-rated arresters afford sufficient protection. Therefore, if other circumstances warrant the use of a non-effectively grounded system, the matter of surge protection need not prohibit such use.

18. Inductive Coordination

It is practically impossible to predetermine inductive coordination situations, because they arise from the interrelation of three factors; inductive influence of the supply system, inductive susceptivness of the communication circuits, and the coupling between the two types of circuits. Therefore, remedial measures may involve reduction in the supply circuit influence, or in the susceptivness of the communication circuits, or in the coupling between the two; or in a combination of two or more of the above.

When the remedial measures can best be applied to the

grounding of the generators, removing the ground from a particular generator may correct the situation, but may require additional equipment to establish a ground to permit proper relaying. Neutral filters are sometimes applicable.

A detailed study of each situation is necessary to determine the best overall engineering solution. A further discussion of this question is given in Chap. 23.

19. Mechanical Stress in Generator Winding

Paragraph 3.130 of ASA Standard C-50 Rotating Electrical Machinery, 1943 Edition, reads as follows:

"A machine shall be capable of withstanding without injury the stresses of a 10-second, 3-phase short circuit at its terminals when operated at rated kva, power factor and 5-percent overvoltage or any other 10-second short circuit provided the machine phase currents under the fault condition are limited by means of suitable reactance or resistance to a value which does not exceed the maximum phase current obtained from a 3-phase fault."

Reference to Sec. 12 shows that when X_0 is less than X_1 , which is usually the case, some form of impedance is required in the generator neutral to permit grounded operation.

20. Transient Overvoltages

This subject is treated in detail in Chap. 14. In any discussion of this subject, it should be recognized that numerous field tests have been made in an attempt to set up and measure high transient voltages resulting from phase-to-ground arcing faults in air. Generally speaking, the overvoltages thus measured have been lower than those indicated by pure theory, or by transient-analyzer studies, and rarely exceeded three times the normal line-to-neutral crest. However, because of the random nature of arcs, it is difficult to capture the maximum overvoltages, unless numerous tests are made and high grade equipment such as a cathode-ray oscillograph is used. Studies on the transient analyzer are usually made by controlling the restriking of the arc to produce the maximum overvoltage. Therefore, the results of transient-analyzer studies are of more value in comparisons of methods of grounding, rather than in accurately predetermining magnitudes.

Switching operations may cause relatively high transient overvoltages, if restriking occurs in the breaker. Accordingly, in evaluating any method of grounding from the viewpoint of transient voltages, it is well to consider whether there will be switching at generator voltage either initially or some time in the future.

Transient overvoltages due to switching have caused electrical failure of equipment, circuit insulation, and lightning arresters. Generally, lightning arresters are not considered as being applied for protection against such transient overvoltages, but evidence is available that shows arresters have operated on transient overvoltages, thus protecting equipment. It is good practice to design the system and to ground it in such a manner, whenever possible, that transient voltages are below arrester breakdown voltage.

For generator grounding, it is commonly accepted that transient overvoltages will be within acceptable limits if the following conditions are met:

1. For application of generator neutral reactors, X_0/X_1 as determined at the machine terminals should be three or less. For purposes of this determination, X_0 and X_1 are the resultant of the generator and system reactances, paralleled.

2. For application of generator-neutral resistances (or the equivalent through a grounding transformer), the current passed through the resistor during ground faults should equal or exceed the capacitive current that would flow during a line-to-ground fault with the resistor disconnected. See Section 18 for a fuller discussion of this point. The upper limit of current passed through a generator neutral resistor is fixed by the desire to avoid excessive power loss, and is customarily held to $1\frac{1}{2}$ times full load generator current, or less. The ratio of X_0/R_0 should preferably not exceed 1.0, including the reactance of the resistor. Cast-iron grid resistors may have power factors of 0.98 and sometimes less, which means that their reactance may be about 20 percent of their resistance, at system frequency.

21. Generator Relaying

It is necessary to consider the effect of the generator grounding device on the operation of protective relays. Most large generators are provided with differential relays. These are fully effective against phase-to-phase faults within the machine. When the generator is effectively grounded, the differential relays also give fairly effective protection against faults to ground.

When the generator neutral is grounded through high impedance, the differential relays lose a considerable amount of their effectiveness against ground faults. This is particularly the case for ground faults near the neutral of the machine. It will usually be necessary to provide a supplementary relay actuated by neutral or zero-sequence current when the machine is grounded through high impedance.

22. Relaying of Feeders at Generator Voltage

When power is distributed at generator voltage, it is necessary that the grounding method be selected giving consideration to that fact. The generator grounding device determines to a large extent the magnitude of the feeder line-to-ground fault current and thus the type and effectiveness of the feeder ground relays. There has been some European use of grounding schemes that limit the ground fault current to around 50 amperes. With feeders having full-load currents of 600 amperes or more, fairly sensitive ground relays are required. Such relays are available, but require more than usual care in selection of current transformers, determination of settings, and maintenance. While their use is, or probably can be made practical, the more usual practice in the United States is to select a grounding scheme that causes the ground fault current to equal or exceed full-load current on the feeders.

With reactor or conventional reactor grounding, adequate current for relaying is readily obtained. Ungrounded operation, or the use of the transformer-resistor combination are not suited for systems having feeders at generator voltage, as there is not sufficient current to permit ready selection of the faulted circuit.

23. Damage at Point of Fault

When a fault occurs within a generator, the affected coils must be replaced. While this is a large job, it is not nearly as serious as the problem of replacing damaged stator iron and restacking the laminations, should that be found necessary. Fortunately, such cases have been rare, but they are nevertheless important. Laboratory studies and field investigations of generator coil failures have been made with the view of determining the relation between fault current, fault duration, and iron burning. So far, these investigations have been non-conclusive, although service experience indicates that if the fault is cleared with standard differential relays and circuit breakers, the damage will be limited to minor burning of the iron, which can be cleaned up without restacking. There is every indication that low fault currents plus fast clearing, however, minimizes fault damage.

At present, the industry attitude seems to be tolerant of moderate to high ground fault currents, where other conditions require it, but to work toward low ground-fault currents, where conditions permit—this occurring mainly with the “unit system” of connection. The more conservative attitude in the latter cases is to trip immediately, even though the fault current be but a few amperes.

24. Generator Neutral Breakers

When a fault occurs within a generator, it is customary to trip the generator armature and field circuit breakers and shut off the input to the prime mover. These operations do not necessarily stop the current through the fault, because a certain time is required for the generator field flux to decay. If a generator neutral breaker is employed, and it also is tripped on the incidence of a ground fault, the fault current immediately drops to a very low value as determined by capacitance effects.

In general, the smaller the ground-fault current (limited by a neutral device), the less justification there is for an automatic neutral circuit breaker.

In some cases non-automatic neutral breakers or disconnect switches are used. These are not operated during faults, but are used to disconnect the neutral for safety or operational reasons. Where several generators are connected to a common neutral bus, which in turn connects to a single neutral grounding device, these breakers or disconnect switches can be used to ground the desired generators to the neutral bus.

25. Time Rating of Neutral Devices

The following is Section 32-2.05 of AIEE Standard No. 32 for Neutral Grounding Devices, dated May, 1947:

“Rated Time—Standard rated time shall be 10 seconds, 1 minute, 10 minutes and extended time.

“It shall be assumed, unless otherwise specified, that a one-minute rating is intended for neutral grounding devices except for ground-fault neutralizers and grounding transformers for use with ground-fault neutralizers, for which a ten-minute rating is assumed.”

When grounding reactors are used on the unit system, a 10-second rating is usually employed as this is consistent with the thermal ability of the generator, and the operation is non-repetitive.

When grounding resistors, reactors, or grounding transformers are used with systems having feeders at generator voltage, a one-minute rating is usually employed, thus allowing for repetitive feeder faults and also for the fact that the neutral device must carry current whenever a ground fault occurs on any of the three phases.

When the distribution-transformer-resistor scheme is used, it has generally been the practice to apply extended time ratings to the resistor. This is done primarily because of the small cost of the resistor, and partly because of the possibility that time-delay tripping might be contemplated in the future.

IV. PRACTICAL CONSIDERATIONS IN GENERATOR GROUNDING

The broad objective in grounding a generator system is to gain additional protection to the generators and other equipment without introducing disproportionate hazards. In the sections which follow, the various generator connections are analyzed with the view of selecting the method of grounding most suitable.

26. Unit System—Fig. 19

From the discussion under Sec. 12, it is evident that solid grounding of the generator neutrals, whether one machine or all of them, will usually result in ground fault currents exceeding the three-phase fault current. From the standpoint of mechanical strength of the generator winding, this situation requires that any grounding of the generator neutrals be through an impedance sufficient to limit the ground-fault current to the three-phase value.

If the neutrals are to be grounded, and no further limitation of ground current is required, other than to secure protection against winding distortion, a neutral reactor is suitable. As to transient overvoltages it is safe, and in the larger sizes has the advantage of lower cost and smaller space as compared with a resistor. A neutral breaker should usually be provided to limit burning in case of internal generator faults because of slow decay of field current and residual voltage even when the field breaker is opened. However in small stations the saving in cost may be worth weighing against the possibility of increased damage to the machine.

An advantage sometimes attributed to grounding generators with the unit system of operation is that most armature-winding faults start as grounds. By grounding the neutral, positive current flow is obtained in case of a fault so that quick and positive relaying is obtained. It is doubtful if there is any pronounced advantage insofar as relaying is concerned over that obtainable with ungrounded operation and ground-fault detectors. Three forms of ground-fault detection are illustrated in Fig. 27. A single potential transformer from neutral to ground is utilized in Fig. 27 (a). A ground fault on any part of the circuit comprising the low-voltage winding of the transformer, connecting leads, or generator winding will produce a voltage on the relay that can be used for tripping or alarm purposes. In Fig. 27 (b) three potential transformers are connected in star, and function in a similar manner. This scheme has an advantage over that of Fig. 27 (a) in that

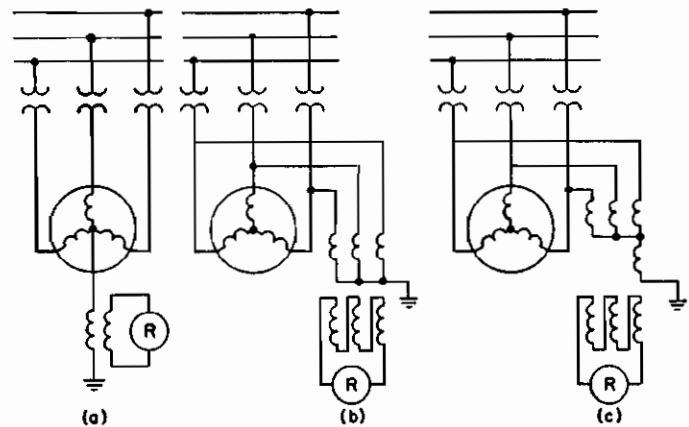

Fig. 27—Alternative methods of ground fault detection on isolated neutral generators.

it can be set more sensitively. In addition for 27 (b) the alarm will be given in case of an open circuit in the primary of a potential transformer. In 27 (a), if there is sufficient bus and transformer capacitance the triangle of line voltage will tend to be stabilized with reference to ground and the residual harmonics will appear between neutral and ground. The relay must be set above any such harmonic voltage, which therefore decreases its sensitivity. Usually this will not be a serious handicap although in extreme cases harmonic voltages as much as 15 percent of normal phase-to-neutral voltage might exist between neutral and ground. The scheme of Fig. 27 (b) avoids this situation. In the scheme of both Figs. 27 (a) and (b), the sensitivity of protection decreases as the ground-fault approaches the neutral point. This is not often a serious handicap as most faults are near the line end. For complete protection anywhere within the windings, the scheme of 27 (c) suggested by R. Pohl can be used. As shown, this involves displacing the neutral continuously by means of an auxiliary winding on one potential transformer. Therefore, when a ground occurs anywhere—even on the neutral lead itself—a voltage will appear across the relay. This scheme is limited to stations where the generator leads and buses are isolated from the system by transformers. Otherwise, capacity effects or neutral grounds on other equipment would cause a continuous indication. These ground fault detectors are in addition to the customary differential protection.

In all of the schemes of Figs. 27 (a), (b) and (c), there is some risk of false indication caused by ground faults on the high-tension system. This can arise as a result of zero-sequence capacitive coupling between high-voltage and low-voltage windings of the step-up power transformers. The zero-sequence diagram of part of the system is illustrated in Fig. 28. As there shown, the capacity effect of the power-transformer windings can be represented by an equivalent star. Part of the zero-sequence voltage on the high-voltage side created by a ground fault is transferred to the low-voltage side by capacity potentiometer effect, and will give some voltage across the fault-detector relay. The magnitude of this voltage is determined by the ratio of transformation, type of high voltage grounding, proximity of fault, amount of capacitances in the transformer

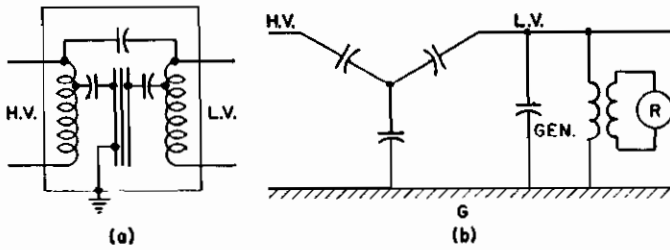

Fig. 28—How zero-sequence capacitive coupling may cause false indications.

- (a) Internal capacitances of two-winding transformer.
- (b) Zero-sequence diagram showing how zero-sequence voltages may be transferred from the high-voltage to the low-voltage side of a transformer where the low-voltage side is ungrounded and of low electrostatic capacity to ground.

branches and the generator, and the burden of the relay. In general, the larger the transformer bank and the higher the voltage, the greater the risk of false operation. The difficulty can be eliminated by paralleling the relay with a dummy load or by using a low-impedance current relay, without interfering with the sensitivity of the protection. While the conditions necessary to such false indication are not likely, one such case has actually been observed. Because of this electrostatic coupling, it is probably undesirable to operate the generators without some form of drainage to ground.

A scheme which avoids the principal objections to ungrounded neutral is shown in Fig. 29. This consists of

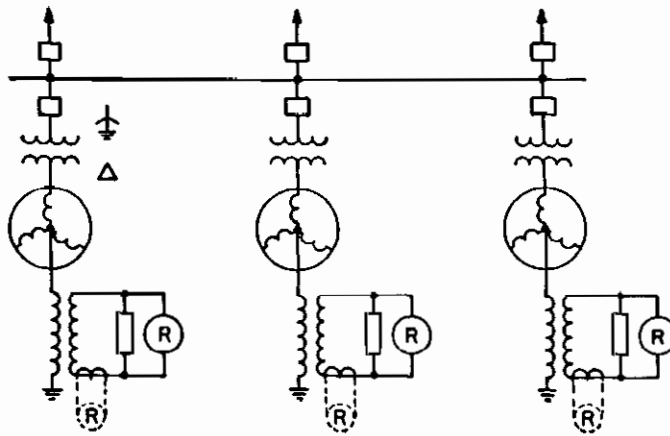

Fig. 29—Grounding scheme for unit system.

connecting the primary of a distribution type transformer between the generator neutral and ground. The secondary of this transformer is shunted by a resistor and by a potential relay for tripping or alarm, as desired. The size of the transformer and resistor depend upon the charging current in case of a line-to-ground fault. This charging current can be obtained by summing up the various components of circuit capacitance, and determining the current that flows if one phase is grounded. The system of Fig. 30 is used for an example. This covers an 11.5-kv, 75 000-kva, 1800-rpm, 60-cycle turbine generator having surge-protective capacitors at its terminals.

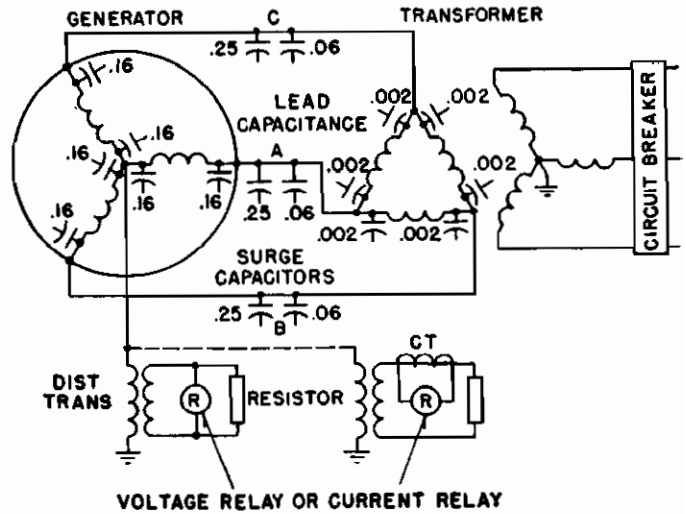

Fig. 30—Capacitance values for grounding through distribution transformer fix kw loss value of secondary resistor.

The zero-sequence capacitance per phase of each circuit component are listed below and totalled.

Generator	0.320	mfd
Generator surge capacitor	0.250	mfd
Generator leads	0.060	mfd
Power transformer	0.004	mfd
Total	0.634	mfd

At 60 cycles, this is a capacitive reactance of $\frac{1}{2\pi fC}$ or $\frac{10^6}{377(0.634)}$ or 4180 ohms. The zero-sequence current is equal to the normal phase to neutral voltage divided by this reactance or $6620/4180=1.58$ amperes. The total capacitive fault current is three times the zero-sequence current or 4.74 amperes.

Transient-analyzer studies have been made to determine the influence of the size of the resistor upon the transient overvoltage produced during an arcing fault. This subject is treated in more detail in Chap. 14. In general, it was found that as the kilowatts dissipation in the resistor is increased, the transient voltages steadily decrease until the resistor kilowatt loss equals the capacitive kva. Increasing the resistor energy loss further gave but little additional reduction in transient overvoltage.

The total current at the point of the fault to ground is the vector sum of the capacitive component of current, and the resistive component. If the resistive component is made equal to the capacitive component, the sum is 1.41 times as much as the capacitive component. Increasing the resistive current beyond equality with the capacitive current produces little further reduction in transient overvoltage, but increases the energy in the arc and the damage therefrom. It has become more or less standard practice to apply the resistor to develop an energy loss equal to or slightly exceeding the capacitive kva during ground-fault conditions.

The kva of the transformer is determined by the product of the primary current and the rated primary voltage,

divided by an overload factor from the following table:

Time	Factor
1 Minute	4.7
5 Minutes	2.8
30 Minutes	1.8
1 Hour	1.6
2 Hours	1.4

The rated primary voltage of the transformer should be approximately $1\frac{1}{2}$ times the generator line-to-neutral voltage, in order to avoid excessive magnetizing inrush, when a ground occurs. It is preferable to disconnect a generator from the system, and remove excitation immediately upon the occurrence of a fault, in order to confine the damage as much as possible. On small systems, some operators prefer to have a ground relay sound an alarm, giving the system operator a chance to make provision for the loss of the generator. In any case, automatic tripping should follow after a reasonable time delay.

For the system of Fig. 30, the capacitive kva developed is $(11.5/1.732)(4.74) = 31.5$ kva. The resistor should dissipate 31.5 kw. If a transformer of 11 500 volts primary, 460 volts secondary were selected, the open-circuit secondary voltage would be $460/1.732$ or 265 volts. The current rating of the resistor would be $31\ 500$ watts/265 volts or 119 amperes, and its resistance $265/119$ or 2.23 ohms.

The kva duty on the transformer is $(11.5)(4.74)$ or 54.5 kva. Note that this exceeds the actual loading, due to the use of a transformer rated on the basis of line-to-line voltage. For a 1-hour duty cycle a transformer rated 54.5/1.6 or 34 kva can be used. A standard 37.5-kva transformer can be selected on this basis. For a 5-minute duty cycle a rating of 54.6/2.8 or 19.5 kva would suffice, and a standard 25-kva transformer can be selected. In general, it is preferable to be conservative on the transformer rating in order that its reactance not be an appreciable factor. It is preferable to apply the resistors on the basis of continuous duty, as their size and cost are usually not significant factors.

Oil-immersed, askarel-immersed, and air-cooled transformers can be used, based on user preference. Either current- or voltage-actuated relays can be used, as indicated by Fig. 30.

The scheme is, in effect, a generator-neutral grounding device of very high resistance in which a fragile and bulky high-voltage resistor is replaced by a step-down transformer and low-resistance resistor. With the proportioning suggested, the possibility of ferro-resonance with an unshunted transformer is avoided, transient overvoltages from switching or arcing are reduced, and there is a reduction in harmonic voltage in the potential indication, making it possible to use lower settings for the ground relay.

27. Power Transmitted at High Voltage, Low-Voltage Bus System Fig. 20

A good many of the arguments with reference to Fig. 19 also apply to Fig. 20, particularly to limitation of ground-fault current. If the neutrals are all ungrounded, however, it is not possible to secure individual selection of the machine developing a ground fault, as the low-voltage tie puts the residual voltage on all machines. Various prac-

tices as to neutral grounding have been employed, perhaps the commonest of which is to provide a neutral bus to which one or more machine neutrals are tied, with a resistor from this bus to ground. The resistance is usually such as to limit the ground-fault current to 0.5 to 1.5 times full-load current of the smallest machine, however no hard and fast rule can be given. With the sensitive differential protection now used, this permits satisfactory tripping for grounds in any machine. Grounding transformers on the low-voltage bus have also been used to insure a source of ground current for relaying. However, it is difficult to hold X_0/X_1 to 3.0 and transient overvoltages may be excessive.

28. Power Transmitted at Generator Voltage, Three-Wire System Fig. 21

The problem of selectively isolating ground faults will usually require that a system of this kind be grounded in some manner. Likewise if cables are used for the distribution circuits, the matter of neutral stabilization and suppression of arcing grounds will require that the grounding impedance be moderately low. One machine alone can be grounded and satisfy these requirements, but a neutral-impedance device will be necessary to limit the maximum current through the machine. Because of the various combinations of machines that may be in service at different times there is some operating complication in insuring that a system ground is always available, and for this reason it is probably desirable that all neutrals be grounded. If a neutral bus is employed, each neutral can be connected to this and a single grounding resistor or reactor used. An alternative and probably more desirable arrangement is to ground each neutral through sufficient impedance that the ground-fault current through each individual machine will never exceed its safe value.

The influence on communication circuits is almost impossible to forecast, because most cases arise out of resonance between the ground reactance and the capacitance to ground of the circuits. With these constantly changing with the growth of the system, about the only course that can be pursued is to consider each case as it arises. Usually a parallel tuned filter in the neutral connection of one generator will cure a specific case of trouble.

29. Power Transmitted at Generator Voltage, Four-Wire System Fig. 22

The general situation with this system connection is the same as on the three-wire system. However since loads are connected from phase wires to the neutral wire, the question of neutral displacement during faults becomes much more important. Otherwise, during a ground fault on one phase, the voltage on the other phases will rise, and lamps, radios and other utilization devices will be flashed. It is therefore essential on a four-wire system that no more impedance be inserted in the neutral connection than necessary to protect the generators against excessively high currents during ground faults. The proper impedance can be calculated by the method of symmetrical components. If all generators are grounded, making $\frac{X_0}{X_1} = 1.0$ for each generator will satisfy the generator requirements.

If $\frac{X_0}{X_1} = 1$ for the entire system, this will hold the line-to-neutral voltage down to normal value (as shown by Fig. 6, Chap. 14) and thus satisfy the load requirements. It is probable that a moderate increase in line-to-neutral voltage during ground faults is permissible because the condition is temporary, so that ratios of $\frac{X_0}{X_1} = 1.5$ or even 2.0 for the system may be feasible. These figures are approximate, as resistance has not been considered, and in some cases, it will be important.

Three possible ways in which neutral impedances can be employed are presented in Figs. 22 (b), (c) and (d). The first is shown merely for the sake of completeness; it serves no necessary function in limitation of current and would prove a liability in excessive neutral displacement and regulation with unbalanced loads.

In both Figs. 22 (c) and (d), the neutral impedance is between generator neutral and ground where it is effective in reducing ground-fault currents. In 22 (c) the regulation to unbalanced loads is slightly better than in 22 (d), but the impedances necessary for neutral stabilization will be usually low compared to the line impedances where there are a number of individual feeders and this point will ordinarily not be important. On many systems the fourth wire will be grounded at each transformer installation, and 22 (d) is necessary in this event. In general 22 (d) represents a more satisfactory connection.

In most power stations, there is considerable shifting of generators in and out of service. With the four-wire system, the dual requirements of prevention of high individual generator currents during ground faults, and restriction of neutral displacement are necessary. The most satisfactory method of maintaining these requirements is to use individual grounding devices with each generator. The generator-neutral breaker may be left closed whether the generator is in or out of service, and only opened in case of a generator fault.

For this type of service reactors are preferable as grounding devices. For a given limitation of current, the distortion of phase voltages to ground will be less than for a resistor because the voltage drop is in phase with the phase-to-neutral voltage of the faulted phase. The cost and space requirements will usually be less. The likelihood of excessively high transient voltages during arcing grounds is small because the $\frac{X_0}{X_1}$ ratio must be kept low on the four-wire system.

30. Power Transmitted at Double Generator Voltage by Auto-Transformers, Fig. 23

Figure 23 (b) is being used to a considerable extent on large systems employing 24 kv or 27.6 kv underground cable distribution systems. Interconnecting and grounding the neutrals of the generators and auto-transformers stabilizes the neutral and prevents excessive voltage stresses in the event of ground faults. Any triple series harmonics present in the generator wave form are passed to the outside lines. On cable systems there is little likelihood of this causing interference with communication circuits. Where the distribution is by overhead lines there

exists some possibility of communication circuit interference. In fact, the case is exactly analogous to that discussed in Section 28.

Figure 23 (c) is similar to 23 (b) except that a delta tertiary has been added. The effect of the tertiary is to decrease the magnitude of the triple series harmonic voltages applied to the outgoing lines and to cause a circulating current to flow in the neutral interconnection. In most cases it is doubtful whether either of these influences exists in sufficient magnitude to be of any practical importance. Assume for example that the delta winding is rated at one-half the kva parts of a one to two ratio auto-transformer. It will then be one-fourth the generator kva rating. The reactance from generator winding to tertiary winding may be 8 percent on the tertiary kva or 32 percent on the generator kva. If the generator zero-sequence reactance is 8 percent, the triple harmonic voltages at the generator terminals will be reduced to about $\frac{3(32)}{3(8+32)}$ or four-fifths

the value without a tertiary. This reduction would ordinarily not be sufficient to correct interference to a satisfactory level. The harmonic circulating current is similarly of small importance from the standpoint of heating. For example, assume 10 percent third harmonic voltage in the generator phase to neutral wave form (a very high figure for modern generators). This would be acting on an impedance of $3 \times (8+32)$ or 120 percent. The circulating current would then be $\frac{10}{120} \times 100$ or 8 percent per phase increasing the I^2R by only $\frac{1}{3}$ percent. See Sec. 15 of this chapter. (NOTE: In both of the above calculations, it was assumed that the generator reactance would increase as the order of the harmonic.) The foregoing discussion shows that where both the generator and auto-transformer are to be grounded and are in the same station, there is little point to adding a delta tertiary winding to the auto-transformer. Should there be an appreciable distance between the generator and the transformer, and particularly if there are paralleling communication circuits this question should be carefully considered, as the flow of transformer magnetizing current or generator triple harmonic circulating current may cause inductive influence.

In Fig. 23 (d) the generator neutral is ungrounded, and the auto-transformer neutral grounded, with a delta tertiary provided. This minimizes all communication circuit influence and generally gives satisfactory stabilization of voltages in the event of ground faults. Generator differential protection is less sensitive for faults in the vicinity of the generator neutral point.

Figure 23 (e) shows the generator neutral grounded and the auto-transformer neutral ungrounded. This connection puts the generator triple series harmonics on the outgoing circuits, but facilitates generator differential protection. The line voltages are properly stabilized in the event of ground faults.

If both generator and auto-transformer grounds are omitted, the generator insulation will be overstressed in the event of a ground fault on the high voltage side of the auto-transformer and this connection should therefore not be used. If the high voltage side of a grounded neutral auto-transformer is connected to an effectively grounded

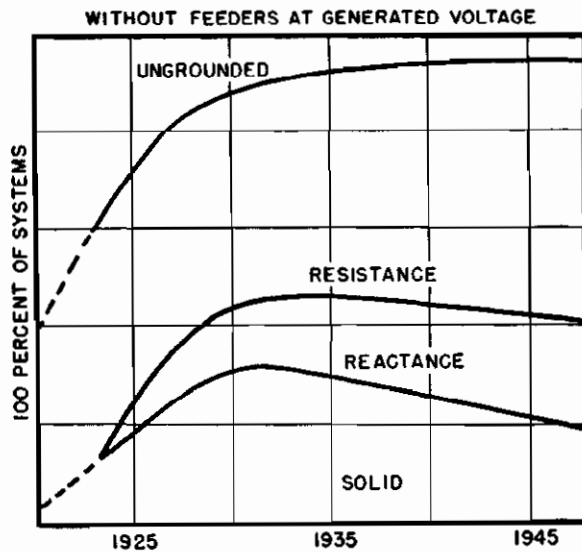

Fig. 31—Relative United States use of grounding methods on generators without feeders at generated voltage.

system (preferably with grounded star-delta transformers at the same station) the tertiary may be omitted whether the generator neutral is grounded or not. The generator neutral will be shifted from ground potential in the event of a ground fault on the system, but not sufficient to overstress the generator insulation.

Generally, a fault to ground on the high-voltage side of the auto-transformer will not result in generator currents exceeding those permissible. For ground faults on the low-voltage side, the generator currents may exceed permissible values unless a reactor is placed between the generator neutral and ground.

31. Trends and Practices in Generator Grounding

Figures 31 and 32 are plotted from data obtained from the Third AIEE Report on System Grounding¹². In most of the cases of "reactance grounding," the grounding reactors are of low ohms, resulting in "effective grounding." "Solid" and "reactance" grounded may therefore be combined as "effective" grounding, and as such, about half of the systems are so grounded. The percentage of effectively grounded systems is decreasing slightly. The "ungrounded" classification includes potential transformer grounding.

REFERENCES

1. Present-Day Practices in Grounding of Transmission Systems, by Woodruff and Stone (Committee Report), *A.I.E.E. Transactions*, April 1923, pages 446-464.

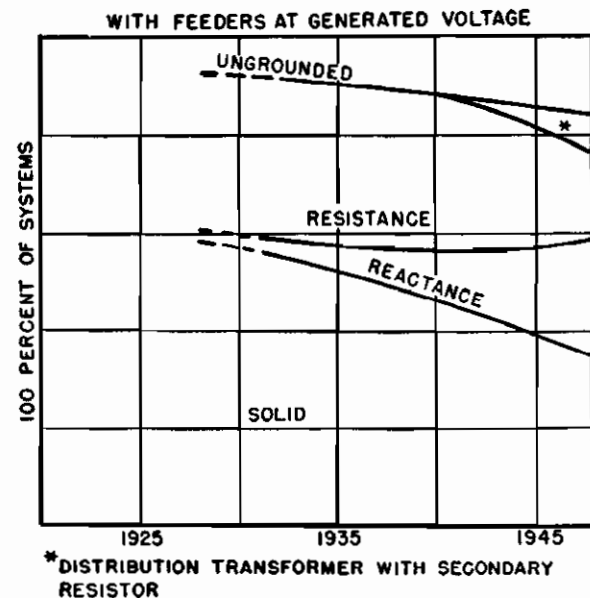

Fig. 32—Relative United States use of grounding methods on generators with feeders at generated voltage.

2. General Considerations in Grounding the Neutral of Power Systems, by H. H. Dewey, *A.I.E.E. Transactions*, April 1923, pages 405-416.
3. Voltages Induced by Arcing Grounds, by J. F. Peters and J. Slepian, *A.I.E.E. Transactions*, April 1923, pages 478-489.
4. Experimental Studies of Arcing Faults on a 75-Kv Transmission System, by Eaton, Peck, and Dunham, *A.I.E.E. Transactions*, December 1931, pages 1469-1478.
5. Present-Day Practice in Grounding of Transmission Systems (Committee Report), *A.I.E.E. Transactions*, September 1931, pages 892-900.
6. Petersen Coil Tests on 140-Kv System, by J. R. North and J. R. Eaton, *A.I.E.E. Transactions*, January 1934, pages 63-74.
7. Some Engineering Features of Petersen Coils and Their Application, by E. M. Hunter, *A.I.E.E. Transactions*, January 1938, pages 11-18.
8. System Analysis for Petersen-Coil Application, by W. C. Champe and F. Von Voigtlander, *A.I.E.E. Transactions*, December 1938, pages 663-672.
9. Power System Faults to Ground, by C. L. Gilkeson, P. A. Jeanne, J. C. Davenport, Jr., and E. F. Vaage, *A.I.E.E. Transactions*, April 1937, pages 421-433.
10. Abnormal Voltage Conditions in Three-Phase Systems Produced by Single-Phase Switching, by Edith Clarke, H. A. Peterson, and P. H. Light, *A.I.E.E. Technical Paper* 40-105.
11. American Standards Association Standards for Neutral Grounding Devices, January 30, 1941.
12. Present-Day Grounding Practices on Power Systems—Third A.I.E.E. Report on System Grounding (Committee Report), *A.I.E.E. Technical Paper* 47-237.

DISTRIBUTION SYSTEMS

Original Authors:

John S. Parsons and H. G. Barnett

Revised by:

John S. Parsons and H.G. Barnett

I. GENERAL

AN electric distribution system, or distribution plant as it is sometimes called, is all of that part of an electric power system between the bulk power source or sources and the consumers' service switches. The bulk power sources are located in or near the load area to be served by the distribution system and may be either generating stations or power substations supplied over transmission lines. Distribution systems can, in general, be divided into six parts, namely, subtransmission circuits, distribution substations, distribution or primary feeders, distribution transformers, secondary circuits or secondaries, and consumers' service connections and meters or consumers' services. Figure 1 is a schematic diagram of a typical distribution system showing these parts.

The subtransmission circuits extend from the bulk power source or sources to the various distribution substations located in the load area. They may be radial circuits connected to a bulk power source at only one end or loop and ring circuits connected to one or more bulk power sources at both ends. The subtransmission circuits consist of underground cable, aerial cable, or overhead open-wire conductors carried on poles, or some combination of them. The subtransmission voltage is usually between 11 and 33 kv, inclusive.

Each distribution substation normally serves its own load area, which is a subdivision of the area served by the distribution system. At the distribution substation the subtransmission voltage is reduced for general distribution throughout the area. The substation consists of one or more power-transformer banks together with the necessary voltage regulating equipment, buses, and switchgear.

The area served by the distribution substation is also subdivided and each subdivision is supplied by a distribution or primary feeder. The three-phase primary feeder is usually run out from the low voltage bus of the substation to its load center where it branches into three-phase subfeeders and single-phase laterals. The primary feeders and laterals may be either cable or openwire circuits, operated in most cases at 2400 or 4160 volts.

Distribution transformers are ordinarily connected to each primary feeder and its subfeeders and laterals. These transformers serve to step down from the distribution voltage to the utilization voltage. Each transformer or bank of transformers supplies a consumer or group of consumers over its secondary circuit. Each consumer is connected to the secondary circuit through his service leads and meter. The secondaries and service connections may be either cable or open-wire circuits.

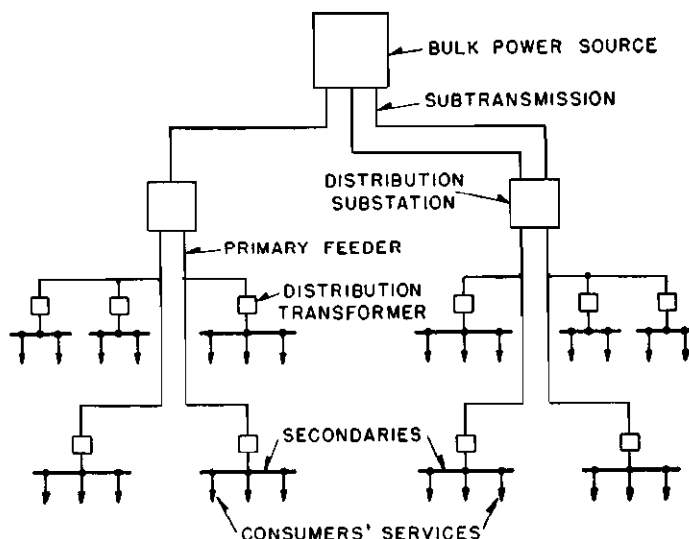

Fig. 1—Typical distribution system showing component parts.

The distribution plant occupies an important place in any electric power system. Briefly, its function is to take electric power from the bulk power source or sources and distribute or deliver it to the consumers. The effectiveness with which a distribution system fulfills this function is measured in terms of voltage regulation, service continuity, flexibility, efficiency, and cost. The cost of distribution is an important factor in the delivered cost of electric power. Approximately 50 per cent of the capital investment in electric power systems in the United States is in the distribution plant.

Briefly, the problem of distribution is to design, construct, operate, and maintain a distribution system that will supply adequate electric service to the load area under consideration, both now and in the future, at the lowest possible cost. Unfortunately, no one type of distribution system can be applied economically in all load areas, because of differences in load densities, existing distribution plant, topography, and other local conditions.

In studying any load area, the entire distribution or delivery system from the bulk power source—which may be one or more generating stations or power substations, to the consumers should be considered as a unit. This includes subtransmission—distribution substations, primary feeders, distribution transformers, secondaries, and services. All of these parts are interrelated and should be considered as a whole so that money saved in one part of the distribution system will not be more than offset by a resulting increase elsewhere in the system.

For different load areas, or even different parts of the same load area, the most effective distribution system will often take different forms. Certain principles and features, however, are common to almost all of these systems. The distribution system should provide service with a minimum voltage variation and a minimum of interruption. Service interruptions should be of short duration and affect a small number of consumers. The overall system cost—including construction, operation, and maintenance of the system—should be as low as possible consistent with the quality of service required in the load area. The system should be flexible, to allow its being expanded in small increments, so as to meet changing load conditions with a minimum amount of modification and expense. This flexibility permits keeping the system capacity close to actual load requirements and thus permits the most effective use of system investment. It also largely eliminates the need for predicting the location and magnitudes of future loads. Therefore, long-range distribution planning, which is at best based on scientific guesses, can be greatly reduced.

II. TYPES OF DISTRIBUTION SYSTEMS

Electric power was originally distributed by radial d-c systems which later developed into the well known d-c network system. For many years this was the standard form of distribution system for the heavy-density load areas where the distribution circuits are usually underground, such as in the business sections of the larger cities. Because power could be transmitted only at the utilization voltage, the d-c system was not suitable for serving economically the more extensive lighter-load areas. After the introduction of alternating current into this country by George Westinghouse, these areas were served by overhead a-c systems of the radial type. The heavy-density load areas in many of the smaller cities, where it was felt that the necessity for service reliability did not warrant the expense of a d-c network system, were also fed from a-c radial systems. For that matter they still are. Most electric power today is distributed by a-c systems. The relatively few d-c distribution systems still in service are gradually being replaced by a-c systems. The following descriptions and discussions of distribution systems are confined to alternating current systems.

1. The Radial System

The radial type of distribution system, a simple form of which is shown in Figure 2, is the most common. It is used extensively to serve the light- and medium-density load areas where the primary and secondary circuits are usually carried overhead on poles. The distribution substation or substations can be supplied from the bulk-power source over radial or loop subtransmission circuits or over a subtransmission grid or network. The radial system gets its name from the fact that the primary feeders radiate from the distribution substations and branch into subfeeders and laterals which extend into all parts of the area served. The distribution transformers are connected to the primary feeders, subfeeders, and laterals, usually through fused cutouts, and supply the radial

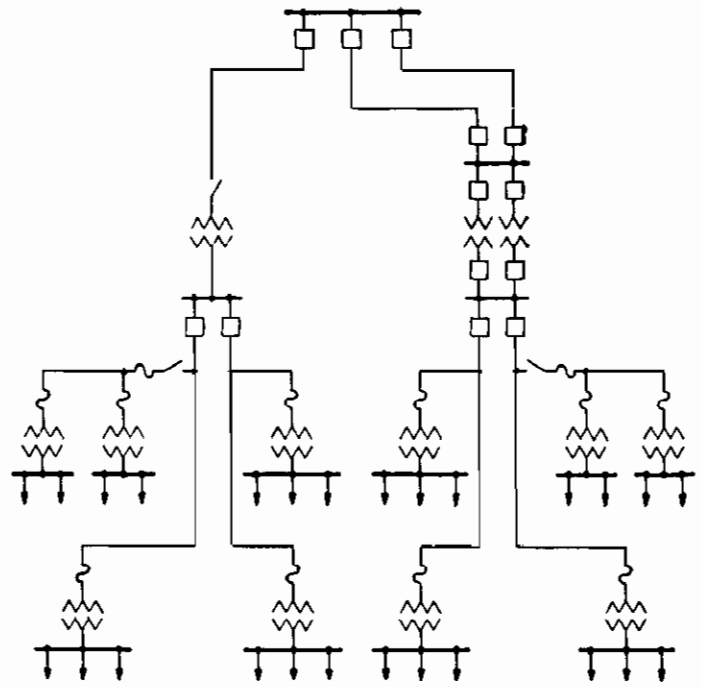

Fig. 2—Simple form of radial-type distribution system.

secondary circuits to which the consumers' services are connected.

Oil circuit breakers arranged for overcurrent tripping are used to connect the radial-primary feeders to the low-voltage bus of their associated substation. When a short-circuit occurs on a feeder its station breaker opens and interrupts the service to all consumers supplied by the feeder. Manually-operated sectionalizing switches are often installed at the junction of the subfeeders and the main feeder. When trouble on a subfeeder has been located the faulty section can be isolated by opening the proper switch, and service can be restored to the remainder of the feeder before repairs are made. The purpose of the fuses in the primary leads of the distribution transformers is to open the circuit in case of trouble in a transformer or on its associated secondary lines and prevent a possible shutdown of a considerable portion of the feeder or the entire feeder on such faults. The subfeeders and laterals are sometimes fused to prevent tripping the feeder breaker at the substation and thus reduce the extent of the outage when a fault occurs on one of them. Obviously, the transformer fuses, branch fuses, and feeder breaker should be properly coordinated so that the circuit will be opened at the proper point to keep the outage to a minimum.

When a fault that is not self clearing develops on any section of the feeder, in one of its associated distribution transformers, or on one of its secondary circuits, a number of the consumers will be without service for a considerable period. All consumers connected to the feeder will, of course, be affected if the fault is located so as to cause the feeder breaker at the substation to open. Experience with faults on open-wire circuits has shown that deenergizing these circuits causes the faults to clear themselves in most cases. For this reason the feeder breakers are often made

to reclose automatically. The reclosing equipment provides one, two, or three reclosures before the breaker is locked open.

Fundamentally the advantages of the radial distribution system are simplicity and low first cost. These result from a straightforward circuit arrangement, where a single or radial path is provided from the distribution substation, and sometimes from the bulk power source, to the consumer. With such a circuit arrangement the amount of switching equipment is small and the protective relaying is simple. Although simplicity and low first cost account for the widespread use of the radial system they are not present in all forms of the system.

The lack of continuity of service is the principal defect of the radial system of distribution. Attempts to overcome this defect have resulted in many forms and arrangements of the radial system. Frequently the system is radial only from the distribution substations to the distribution transformers. Because of the many system arrangements encountered it is sometimes difficult to determine in what major type a system should be classified. To aid in such classification and to follow more readily the discussion of radial systems, it should be remembered that a radial system is a system having a single path over which current may flow for a part or all of the way from the distribution substation or substations to the primary of any distribution transformer.

Subtransmission.—Power is transmitted from the bulk power source or sources to the distribution substations over the subtransmission circuits. These circuits may be simple radial circuits, parallel or loop circuits, or a number of interconnected circuits forming a subtransmission grid or network. Several factors influence the selection of the subtransmission arrangement for supplying distribution substations in a radial system. Two of the most important are cost and reliability of power supply to distribution substations.

A radial arrangement of subtransmission circuits such as that shown in Fig. 3 results in the lowest first cost. This form of subtransmission is not usually employed be-

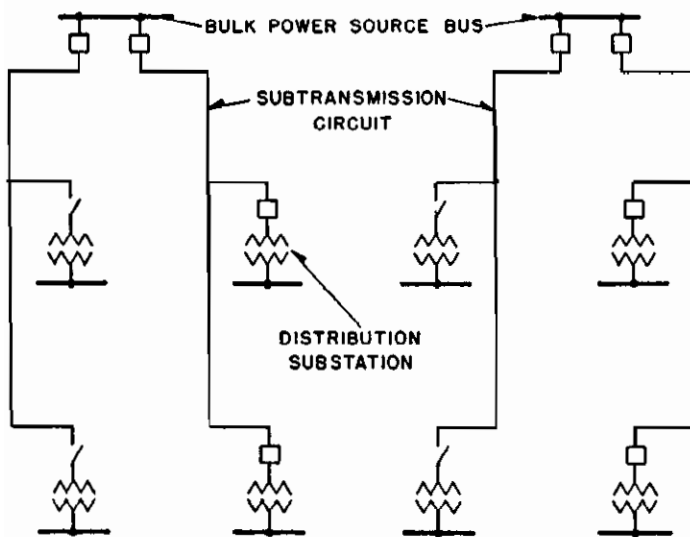

Fig. 3—Simple form of radial type subtransmission circuits.

cause of the poor service reliability it provides. A fault on a radial subtransmission circuit results in a service interruption to all loads fed over it. The economical use of subtransmission circuits and associated circuit breakers dictates that each subtransmission circuit carry a relatively large block of load. Thus a fault on a radial subtransmission circuit results in the loss of considerable load, which usually means that a large area and many consumers are without service.

An improved form of radial subtransmission is shown in Fig. 4. Each radial subtransmission circuit serves as a

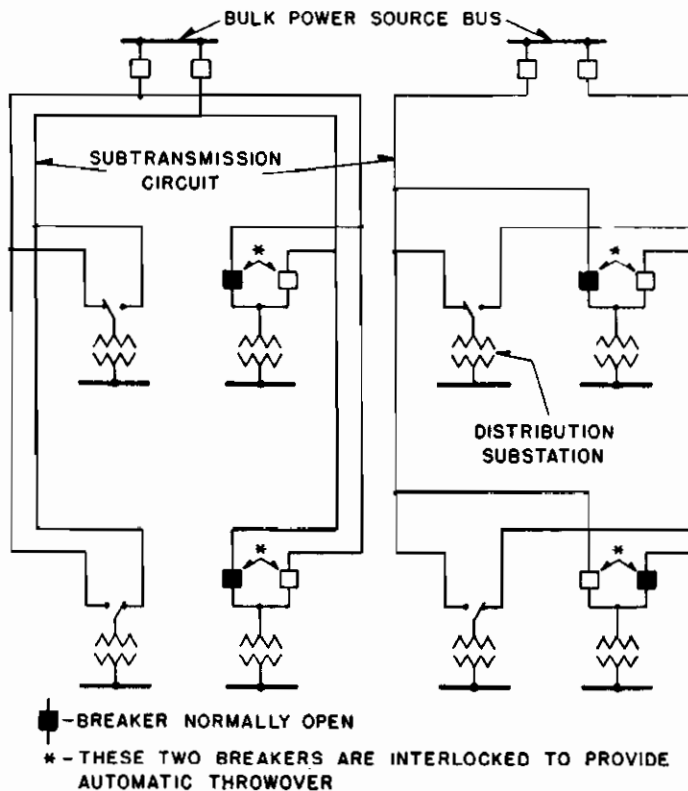

Fig. 4—Improved form of radial type subtransmission circuits.

normal feed to certain distribution substation transformers and as an emergency feed to others. This arrangement permits quick restoration of service when a radial subtransmission circuit is faulted. The substation transformers normally fed from the faulty circuit are each provided with an emergency circuit to which they can be switched either manually or automatically. This arrangement does not prevent an extensive service interruption for a short time and requires spare capacity to be built into the radial subtransmission circuits.

Because extensive service interruptions cannot often be tolerated, the subtransmission for a radial system usually takes the form of parallel or loop circuits or of a subtransmission grid. Whether a loop or a grid arrangement of subtransmission circuits is preferable will depend largely on conditions in the particular load area, such as the load distribution, the topography, and the number and location of the bulk power sources.

A parallel- or loop-circuit subtransmission layout is

shown in Fig. 5, on which no single fault on any circuit will interrupt service to a distribution substation. All circuits must be designed so that they will not be overloaded when any one circuit is out of service. Two parallel circuits are considered to be a sectionalized loop supplying one distribution substation. However, two parallel circuits running over the same right-of-way are not nearly as reliable as two circuits following different routes. A fault on one circuit may involve the other if the two circuits are closely adjacent. This is not as likely to result, however, with cable circuits as with open-wire circuits.

The term "loop" as used here should not be confused with the term "ring". By loop is meant a circuit which starts from a power-supply point or bus and after running through an area returns to the same point or bus; whereas a ring is a circuit or circuits which start from a power-supply point or bus, tie together a number of power-supply points or buses, and return to the starting point or bus. In other words, a ring is a loop from which substations can be supplied and into which power is fed at more than one point. The ring arrangement is quite often used for subtransmission. It is a simple form of subtransmission network, and as the system grows it very often develops into a grid.

The network form of subtransmission is flexible in that it can readily be extended to supply additional distribution substations in the area it covers with a relatively small amount of new circuit construction. It requires a large number of circuit breakers, however, and is difficult and costly to relay. The network or grid form of sub-

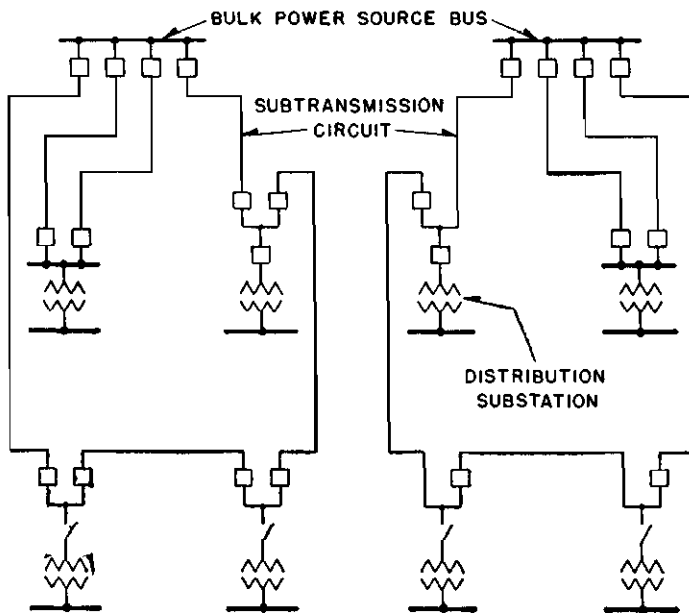

Fig. 5—A parallel- or loop-circuit subtransmission layout.

transmission shown in Fig. 6 provides greater service reliability to the distribution substations than the radial and loop forms of subtransmission. This is true particularly when the distribution system is supplied from two or more bulk power sources, because it is possible for power to flow from any bulk power source to any distribution

substation. This paralleling of bulk power sources through the subtransmission circuits also has the advantage of tending to equalize the load on the bulk power sources.

In a large distribution system any two or even all of the above forms of subtransmission may be employed be-

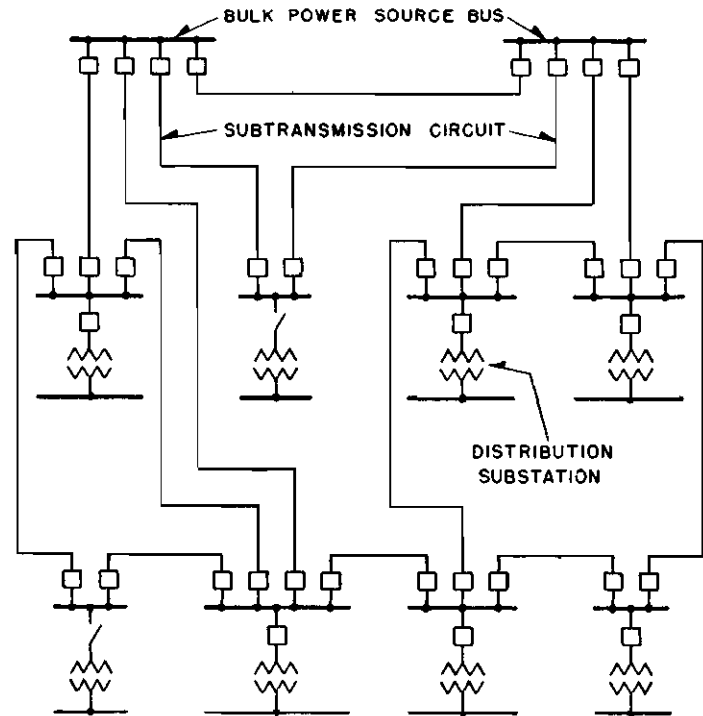

Fig. 6—Network or grid form of subtransmission.

tween the bulk power sources and the various distribution substations, depending upon the service requirement of the different substations and economic considerations. The form of subtransmission employed is also influenced by the design of the distribution substations used.

Distribution Substations.—Twenty years ago it was common practice to use large distribution substations. The transformer capacity in many of them lay between 15 000 and 30 000 kva. This, of course, meant that every reasonable precaution was taken to insure continuous power supply to these stations. It also meant that systems employing these large stations contained a relatively small mileage of subtransmission circuits compared to the mileage of primary distribution circuits. Except in the areas of heavy load density this meant that the load was being carried too far at the lower distribution voltage and not far enough at the higher subtransmission voltage to give an economical distribution system. The use of these large stations also resulted in a system not readily adapted to changing load conditions. The substation capacity could not be increased in small increments economically to take care of load growth. Also as the load grew, it often grew away from the locations where it was assumed it would grow when the large substation locations were selected. This further increased the distance over which the load had to be carried at distribution voltage. Thus as time passed these systems became

even less economical than when first designed and installed. In order to increase the economy and flexibility of distribution systems the trend during recent years has been toward the use of more and smaller distribution substations, with a resulting increase in the mileage of subtransmission circuits and a decrease in the mileage of primary distribution circuits.

Along with the change in the size of distribution substations has gone a change in the subtransmission arrangements used. This change has been a simplification of the subtransmission layout and as large a reduction in the number of high-voltage circuit breakers as is consistent with service requirements. These changes have led to an increased use of the radial form of subtransmission along with the simpler loop and network forms. There is also a growing tendency to treat a subtransmission circuit and its associated substation transformer or transformers as a unit, thus eliminating high-voltage circuit breakers and doing the necessary automatic switching on the low-voltage side of the substation transformer. When this is done the high-voltage bus in the substation is omitted. In the larger substations however, it will at times prove economical to employ a high-voltage bus and omit the low-voltage bus.

The economical sizes of distribution substations to employ on a particular radial system depend on load density, subtransmission arrangement, unit cost of subtransmission circuits, unit cost of primary distribution feeders, cost of land, and other factors. Because many factors influence the economical design of a distribution system and because existing distribution plant and local conditions and requirements must be taken into account, many distribution substation designs are required. Some of the more basic designs are illustrated and will be discussed briefly.

Perhaps the simplest form of distribution substation is that shown in Fig. 7 (a). It consists of a high-voltage disconnecting switch, a transformer bank, and a primary-feeder breaker in the low-voltage leads of the transformer bank. The transformer bank can consist of three single-phase transformers or one three-phase transformer. Now that more small substations are being used the trend is definitely to the use of three-phase transformers. A three-phase transformer makes a neater and more compact substation, reduces the number of bushings, valves, and fittings to be inspected and maintained, and saves installation time and expense. The use of single-phase transformers has the advantage of permitting open-delta operation of the substation at reduced capacity, which is not possible when using a three-phase transformer. Modern transformers fail so rarely, however, that this disadvantage of the three-phase transformer is more than outweighed by its advantages. When it is remembered that we are talking primarily about transformer banks of from 600 to 3000 kva it is often possible to keep a spare transformer at some central point. This transformer can be taken to any substation whose transformer fails. Such a procedure may, however, take considerable time particularly if the transformer to be transported is large. A better solution to the problem of quickly restoring service from a small distribution substation whose three-phase transformer has failed is to have a portable substation, that

can easily and quickly be taken to any of the distribution substation sites and connected temporarily to serve the load in such an emergency.

The substations of Fig. 7 may or may not require voltage regulating equipment. This equipment may take the form of automatic tap-changing-under-load, built into the transformer, or one or more separate voltage regulators. Tap-changing-under-load equipment on a three-phase transformer provides voltage regulation in the least space and usually at the lowest cost. For small substations with one primary feeder or relatively few low capacity primary feeders a single set of regulating equipment is usually sufficient to maintain satisfactory voltage on the load side of the substation transformer bank. Large substations having many primary feeders of larger capacity,

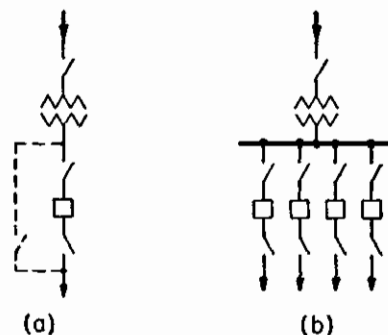

Fig. 7—Simplest forms of distribution substations.

however, ordinarily require voltage regulators on all feeders. In these large substations it is sometimes satisfactory to employ bus regulation, as in the small substations, supplemented by regulators on only a few of the primary feeders. Where this can be done it is usually more economical than using feeder regulators throughout.

The single primary-feeder breaker of Fig. 7(a) is usually provided with overcurrent relays and automatic reclosing equipment. Its interrupting capacity need be equal only to the maximum fault current through the transformer. It should be remembered, however, that the interrupting rating of the breaker is affected by the reclosing cycle. In order to permit safe inspection and maintenance of the breaker, disconnecting switches are shown on both sides of it. If there is no possibility of the primary feeder being energized from another source at some point on the system, the disconnecting switch on the load side of the breaker can be omitted. However, switches on both sides of the breaker are preferable. If the load on the primary feeder cannot be carried by some other feeder or feeders, when the feeder breaker is tripped and its associated disconnects are opened, it must be dropped while the breaker is being inspected or maintained. Sometimes this is not permissible and then a by-pass disconnecting switch, connected as indicated by the dotted lines, should be used. By closing this by-pass switch and then opening the breaker and its two disconnecting switches, the breaker can be isolated for maintenance without interrupting service to the loads on its associated feeder. Should a feeder fault occur under this condition it must be cleared by the breaker in the subtransmission circuit supplying the substation or by a breaker or fuses in the primary feeder. Although the prob-

ability of a fault occurring while the primary feeder breaker is out of service is small, provision should be made for clearing the fault from the system without serious damage.

For safety, ease of inspection and maintenance, and compactness, lift-up or draw-out type breakers are now quite commonly used as the primary-feeder breakers in distribution substations. These breakers provide the disconnecting-switch features on each side of the breaker, as shown in Fig. 7(a), interlocked in such a way that the disconnects cannot be opened until the breaker is tripped. By having a spare breaker that can be inserted in place of the one removed, it is necessary to interrupt service to

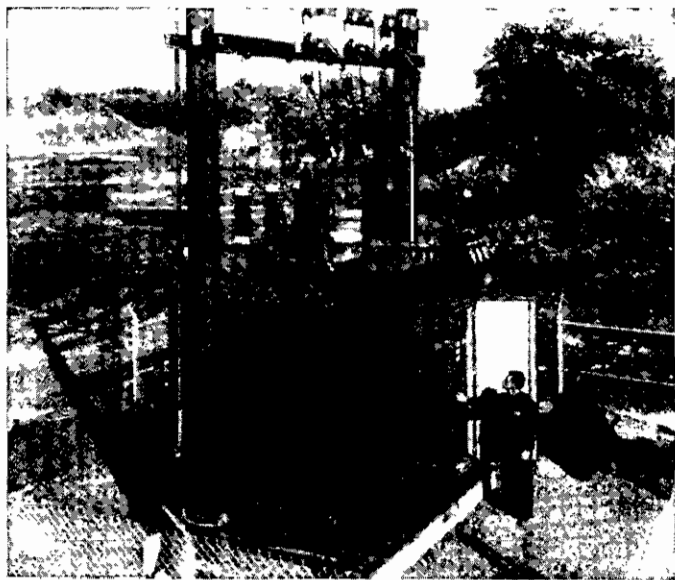

Fig. 8—1500 kva CSP power transformer in service in Pennsylvania. High voltage—13.2 kv delta; low voltage—2500/4340 Y.

the load only for a very short time when work is to be done in a feeder breaker. If even a momentary interruption is serious, a spare cell or compartment can be provided into which the spare breaker can be placed and closed in parallel with the breaker to be worked on before it is tripped and removed. Either of these arrangements has the advantage of leaving the primary feeder with normal protection against a fault that might occur while the normal feeder breaker is being serviced. A spare breaker in almost all cases provides satisfactory inspection and maintenance facilities, and the expense of a spare cell or compartment to prevent a very short time interruption to service can rarely be justified.

The substation shown in Fig. 7(b) is similar to that of Fig. 7(a) except that it has a low-voltage bus and several primary feeders instead of one. It is preferred to the single-feeder station where the magnitude or nature of the load is such that it is necessary or desirable to split the load between several primary feeders. Both of the stations of Fig. 7 are usually supplied over a single radial-subtransmission circuit. In each case the transformer is connected directly to the supply circuit through a disconnecting switch. The disconnecting switch should never be opened under load but should be capable of opening the transformer exciting current. To prevent accidental opening under load the switch should preferably be inter-

locked with the primary feeder breaker or breakers so that it cannot be opened unless this breaker or breakers are open. No breaker is used on the high-voltage side of the transformer bank because the possibility of trouble in a transformer or in the connections between the transformer and the feeder breaker or breakers is remote. Connecting the substation directly to the subtransmission circuit without a high-voltage breaker is no more likely to produce an outage of the circuit than is extending the subtransmission circuit a few hundred feet. Should a fault occur in the transformer bank or its low-voltage connections to the primary-feeder breaker or breakers, the breaker in the subtransmission or supply circuit trips to clear the fault. Sometimes the rating of the transformer bank is so small in comparison with the rating of its associated supply circuit that the current flowing to a fault in the transformer winding or between the transformer and the primary feeder breaker or breakers is insufficient to trip the breaker in the supply circuit. To prevent damage to the transformer under such a condition and to disconnect the substation from the supply system, fuses or protective links can be inserted in the high voltage leads of the transformer either inside the transformer tank or external to it. These protective links must be properly coordinated with the feeder-breaker relaying so that their blowing time is longer than the tripping time of a feeder breaker for all currents that can result from faults on the low-voltage side of the transformer.

Instead of fuses or protective links on the high side of the transformer, where the substation capacity is small compared with that of its associated subtransmission circuit, a circuit breaker can be used. Because of the high voltage of the supply circuit and the fact that the interrupting duty on the high-voltage breaker is determined by the characteristics of the supply system, the cost of such a breaker is likely to be out of proportion to the cost of the remainder of the small substation and excessive for the amount of load controlled. For a single-circuit substation such as shown in Fig. 7(a) it is sometimes possible to justify a breaker on the high-voltage side of the transformer by omitting the primary-feeder breaker on the load side of the transformer. If the feeder breaker is omitted a disconnecting switch can be used in its place to insure complete isolation of the transformer where necessary. When using only a high-voltage breaker its over-current relays must be set to trip on both transformer and primary feeder faults. Except in the case of a cable feeder, it is desirable to have the breaker automatically reclose on feeder faults but it is undesirable to have it reclose on a fault in the transformer. Relaying to accomplish this becomes unduly complicated and questionable in operation. Thus it is usually desirable to retain the primary-feeder breaker when a high-voltage breaker is used. In the multiple-feeder station of Fig. 7(b) the primary-feeder breakers are used either with or without a high-voltage breaker on the supply side of the transformer.

A distribution substation with a single subtransmission supply circuit will often be subjected to too many outages of considerable duration to be satisfactory, because of faults on the supply circuit that must be located and repaired before service can be restored. In order to restore

service quickly when a fault occurs on the substation's normal supply circuit, an alternate supply circuit can be brought to the substation and a double-throw disconnecting switch or two interlocked disconnecting switches used on the high-voltage side of the transformer as shown in Fig. 9. When the normal supply circuit is deenergized because of a fault on it, the substation transformer can be manually connected to its alternate supply circuit by the double-throw disconnecting switch and service thus quickly restored to the loads fed through the substation. After the normal supply circuit is repaired and reenergized it is usually desirable to reconnect the substation to it. To do this the disconnecting switch must be capable of interrupting the transformer exciting current, or the alternate supply circuit must be deenergized when the transfer is made. Deenergizing the alternate circuit involves undue complication and is usually impractical because the alternate feed to this substation also supplies some other substation or substations. Because most disconnecting switches are incapable of interrupting load current, the double-throw switch should be interlocked so that the primary-feeder breaker or breakers must be open before the switch can be moved from one position to another. In a multiple-feeder substation such as that shown in Fig. 9(b) it may be desirable to use a transformer breaker in the secondary leads of the transformer as shown in order to simplify the switching procedure and the interlock circuits.

The double-throw disconnecting switch of Fig. 9(a)

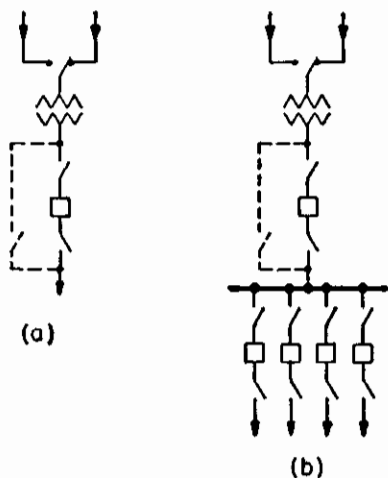

Fig. 9—Distribution substations with alternate subtransmission supply to reduce duration of service interruptions.

and (b) can be replaced by two manually-operated high-voltage breakers, one in each supply circuit, interlocked so that only one can be closed at a time. If this is done, no interlocks with the primary-feeder breaker or breakers are necessary to prevent opening load current. Where high-voltage breakers are used the transformer breaker is in practically all cases omitted. To do this switching with breakers, particularly oil breakers, they should be capable of interrupting any fault current that might flow through them, because of the remote possibility that a fault may occur while performing the manual transfer.

The decision between the use of a disconnecting switch or breakers is primarily an economic one and the cost will usually favor the disconnecting switch.

The station layouts discussed in connection with Fig. 9 (a) and (b) permit reasonably quick restoration of service when a fault occurs on the subtransmission circuit supplying the station. This ability to restore service is dependent on arranging the two circuits to each station so that a fault on one does not involve the other. A transformer failure, however, causes a relatively long interruption of service to the loads fed by the substation.

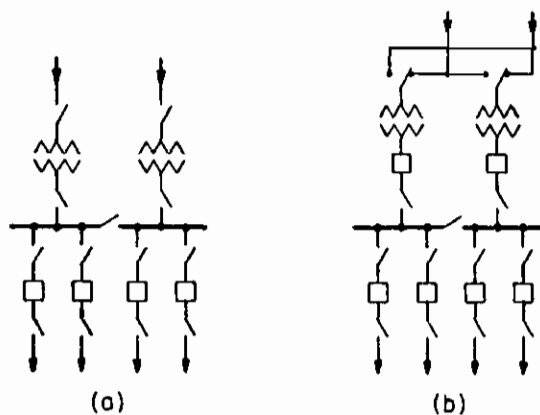

Fig. 10—Distribution substations with duplicate transformers and subtransmission circuits to reduce duration of service interruptions due to transformer failures.

Such interruptions are infrequent but sometimes are serious. To guard against relatively long service interruptions resulting from transformer trouble, substations as shown in Fig. 10 can be used. Because two subtransmission circuits are brought to each substation to allow quick restoration of service when a fault occurs on one of them, as discussed in connection with Fig. 9, the substation transformer capacity can be divided into two banks and one bank normally connected to each supply circuit. With one transformer out of service the remaining bank should be able to carry the entire substation load. Using self-cooled transformers this requires 100 per cent spare transformer capacity in the station. By equipping each of the transformers with automatic air-blast, however, the rating of each of the two banks can be reduced to 75 per cent of the substation rating, or in other words the amount of spare self-cooled transformer capacity can be reduced to 50 per cent. The use of three supply circuits and three transformer banks further reduces the spare transformer capacity.

The distribution substation shown in Fig. 10(a) is similar to that of Fig. 7(b) except that two supply circuits are run to the station and the transformer capacity is divided into two banks. Each of the two banks has a self-cooled rating approximately equal to 75 per cent of the substation rating and is equipped with automatic air-blast. The station is normally operated with the low-voltage bus split into two sections so that each transformer supplies half of the substation load. This method of operation has the advantage of reducing the short-

circuit duty on the primary-feeder breakers. Supplying the load from two separate bus sections instead of connecting all primary feeders to a single bus means less advantage is normally taken of the diversity between primary feeders. This has no effect on the amount of substation transformer capacity required, however, because this capacity is determined by the condition of one transformer out of service, at which time the bus is operated closed and full diversity among all primary feeders is obtained. To prevent the two transformers operating in parallel the load-break disconnecting switch or breaker between the two bus sections is interlocked so that it cannot be closed unless one of the two disconnecting switches in the secondary leads of the transformers is open. When a fault occurs in one of the supply circuits or its associated transformer the supply-circuit breaker trips and deenergizes the supply circuit and transformer thus dropping half of the substation load. This load can be picked up in a relatively short time, however, by opening the low-voltage disconnecting switch associated with the deenergized transformer and then closing the switch between the two bus sections. The entire load of the substation, after this switching operation, is carried through the one remaining transformer. If the fault is in the deenergized transformer and not in its associated supply circuit, the supply circuit can be reenergized to feed other stations connected to it after the disconnecting switch on the high-voltage side of the defective transformer has been opened. When the defective supply circuit or transformer is repaired or replaced the transformer disconnecting switch should be closed before the bus sectionalizing switch or breaker is opened to prevent dropping load. To insure against operating the transformers in parallel, except momentarily, it is best to use a bus-sectionalizing breaker which automatically trips when both low-voltage transformer disconnecting switches are closed.

The substation illustrated in Fig. 10(b) is similar to that of Fig. 9(b) except that the transformer capacity is divided between two banks and the low-voltage bus is normally operated in two sections just as described for the station of Fig. 10(a). This substation differs from that of Fig. 10(a) in that the only time both transformers cannot be used to supply the substation load is when one transformer fails. If a fault develops on a subtransmission circuit the associated transformer can be switched to the remaining supply circuit, after its low-voltage breaker has been opened, thus making both transformers available for carrying the substation load. In both of the substations of Fig. 10 the switching is so arranged that the two transformers cannot be operated in parallel except momentarily. This reduces the short-circuit duty on the primary-feeder breakers when compared with the stations of Figs. 7(b) and 9(b) having the same load ratings.

All substations discussed thus far have involved an outage to all or a part of their load when a fault occurred in a transformer or on the associated subtransmission circuit. The stations differ in the extent of the outage and in the length of time required to restore service to the affected loads, and in each case the restoration of service requires some manual switching. By additional expense a marked decrease in service restoration time can be secured

by using automatic throw-over substations such as those in Fig. 11. The substation shown in Fig. 11(a) is similar to that of Fig. 9(b) except that two high-voltage breakers have been used to obtain the automatic throw-over feature. Only the breaker associated with the normal supply circuit is ordinarily closed. When a fault occurs on that circuit the breaker trips because voltage is absent. Its opening causes the other high-voltage breaker in the alternate supply circuit to close. The return to the normal supply circuit after repairs have been made can be either manual or automatic. If the two supply circuits cannot be momentarily paralleled the advantage of using manual reconnection is that the substation can be switched to its normal circuit when a short service interruption is least objectionable. An automatic reconnection functions to switch the transformer to its normal supply circuit when the circuit is reenergized at about normal voltage. The substation shown in Fig. 11(b) is similar to the station of

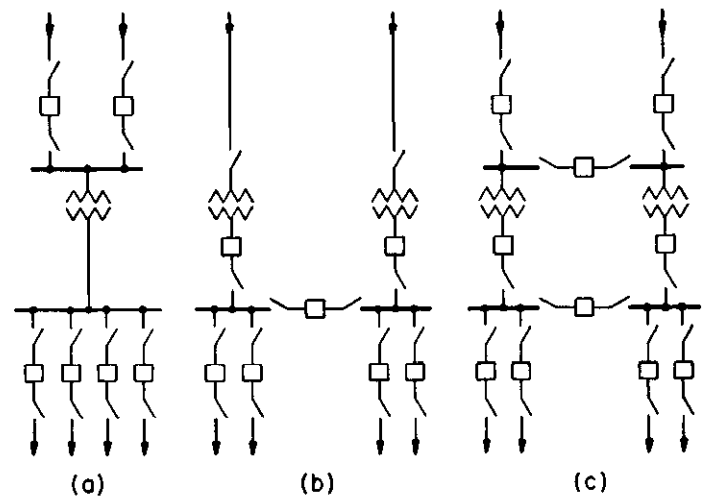

Fig. 11—Throw-over type distribution substations to automatically restore service and minimize the duration of service interruptions resulting from subtransmission or transformer faults.

Fig. 10(a) except for the use of breakers in the low-voltage leads of the transformers and between the two bus sections to obtain the automatic throw-over feature. The bus sectionalizing breaker is open under normal operating conditions. It is arranged to close automatically when either of the transformer breakers open, and to reopen when both transformer breakers are closed. This opening of the sectionalizing breaker after both transformer breakers are closed has the advantage of not dropping load when returning to normal operating conditions. Sometimes it is objectionable to parallel the two supply circuits even momentarily. Then the sectionalizing breaker is arranged to trip when there is about normal voltage on the low-voltage side of both transformers. The tripping of the sectionalizing breaker in this case is arranged to close whichever transformer breaker is open. When a supply circuit or transformer fault occurs the associated supply circuit breaker trips. Because of loss of voltage the transformer breaker associated with the deenergized transformer opens. The opening of this breaker causes the bus-

sectionalizing breaker to close and quickly reenergize the deenergized bus section through the good transformer. Thus the half of the substation load that was dropped as a result of the fault is automatically picked up within a second or two by connecting it to the good transformer and subtransmission circuit. After the faulted supply circuit or transformer is repaired and about normal voltage is restored on the low-voltage terminals of the transformer, the associated transformer breaker automatically recloses—either just before or just after the sectionalizing breaker trips, depending upon the control scheme used—thus restoring the station to its normal operating condition.

In the station just discussed either a supply circuit or a transformer fault results in the loss of half the transformer capacity until repairs can be made. By employing both high-side and low-side throw-over in a two transformer substation as shown in Fig. 11(c) all transformer capacity can be utilized at all times except when a transformer fault occurs, just as in the case of the manual throw-over station of Fig. 10(b). The low-side throw-over functions similar to that of the station shown in Fig. 11(b). The high-side throw-over requires the use of three high-voltage breakers connected as shown in Fig. 11(c). Normally the substation operates with both bus-sectionalizing breakers open and with half of the station load supplied over each subtransmission circuit and through each transformer. The high-voltage sectionalizing breaker is interlocked with the two high-voltage transformer breakers so that it closes when either of these breakers opens, because of loss of voltage on its supply side, and opens when both of these breakers close. If the momentary parallel of the two supply circuits resulting from this method of control is objectionable, the sectionalizing breaker can be made to open when about normal voltage exists on the supply side of both high-voltage transformer breakers. The opening of the sectionalizing breaker, in this case, causes the open transformer breaker to close. The sectionalizing breaker is also equipped with overcurrent or differential relaying inasmuch as it also functions as a transformer breaker when either supply circuit is deenergized. When a supply-circuit fault occurs the circuit is disconnected from the system by the circuit breaker at its source end. The removal of voltage from the supply circuit causes the associated high-voltage transformer breaker to open. As a result the high-voltage sectionalizing breaker closes and reenergizes the deenergized transformer and low-voltage bus section over the good subtransmission circuit. Restoration of voltage to the faulty supply circuit after repairs are made causes the associated high-voltage transformer breaker to reclose and the high-voltage sectionalizing breaker opens and restores the station to its normal operating condition.

When a transformer fails its associated high- and low-voltage breakers are tripped by the overcurrent relays of the high-voltage transformer breaker or by differential relaying. They remain open until manually reclosed. The opening of the low voltage transformer breaker causes the low-voltage bus-sectionalizing breaker to close and connect half of the substation load, which was temporarily dropped, to the good transformer. After the defective transformer is repaired or replaced and its associated high-voltage or

high- and low-voltage breakers are closed the low-voltage bus sectionalizing breaker opens. This sectionalizing breaker is arranged to close when either of the low-voltage transformer breakers are opened, and to open when both of these breakers are closed if the voltage on the transformer side of both is about normal. This voltage check prevents the accidental dropping of half the substation load should an attempt be made to return the transformer to service by closing its low-voltage breaker without first closing its high-voltage breaker. Should the resulting momentary paralleling of the two supply circuits through the substation transformers be objectionable, the section-

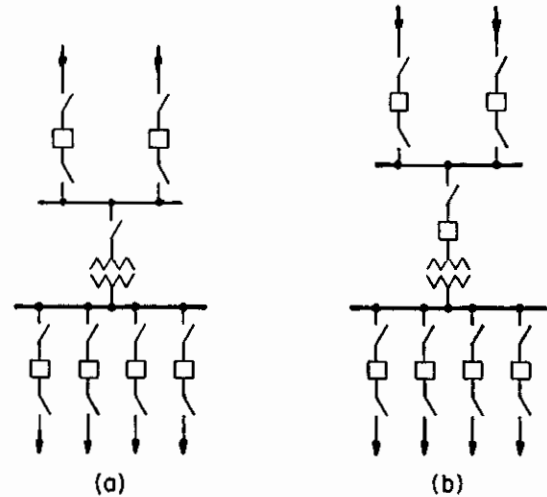

Fig. 12—Distribution substations with duplicate supply circuits to eliminate service interruptions due to subtransmission faults.

alizing breaker can be arranged to open when the voltage on the supply side of both high-voltage transformer breakers is about normal. The opening of the low-voltage sectionalizing breaker causes the open low-voltage transformer breaker to close.

Automatic-throwover distribution substations can rarely be justified except where the two subtransmission circuits supplying the station cannot be paralleled and quick restoration of service is necessary after a supply circuit or transformer fault occurs. To obtain the automatic-throwover feature several more circuit breakers are usually required than in the substations previously discussed and the control of these breakers is relatively complicated. Substations can be built, using no more circuit breakers and simpler relaying, that prevent even a momentary service interruption when a subtransmission-circuit or transformer fault occurs.

Two types of distribution substations that continue to supply all of their load when a supply circuit fault occurs are shown in Fig. 12. The two supply circuits for the substation of Fig. 12(a) are connected to a high-voltage bus through circuit breakers. These breakers are normally controlled by directional-overcurrent relays that trip when fault current flows from the substation high-voltage bus toward the power source. When a fault occurs on a supply circuit the associated high-voltage breaker at the substation and the breaker at the source end of the circuit trip

and disconnect the faulty circuit from the system. The substation continues to be supplied over the good sub-transmission circuit with a voltage dip as the only disturbance to its loads. The two high-voltage breakers at the substation are also equipped with over-current relays, which have a longer time setting than the directional-

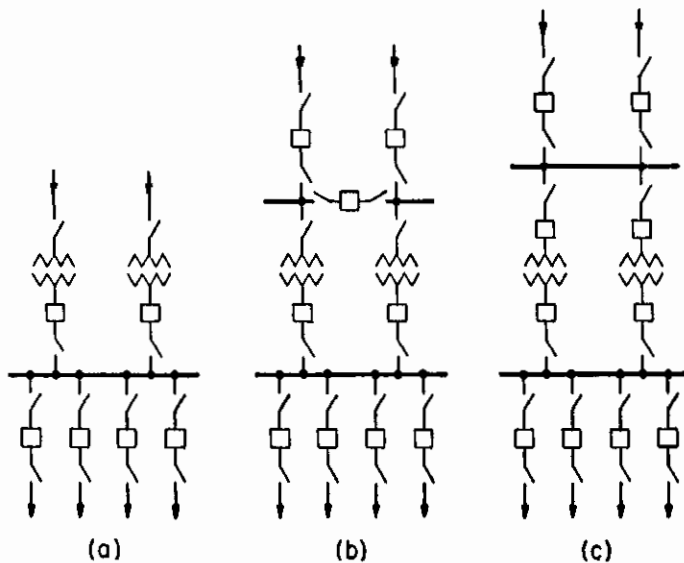

Fig. 13—Distribution substations with duplicate supply circuits and transformers to eliminate service interruptions due to subtransmission or transformer faults.

overcurrent relays previously mentioned, to trip both breakers if the transformer fails. The opening of these two breakers when the transformer fails may be objectionable because the two supply circuits may be parts of a loop or ring that should be continuous. The substation can be

modified by the addition of a high-voltage transformer breaker as shown in Fig. 12(b) so that the supply-circuit breakers do not open when a transformer fault occurs. Supply-circuit faults in this station are cleared just as they are in the station of Fig. 12(a), however, transformer faults are cleared by the high-voltage transformer breaker. A transformer fault in either of the substations of Fig. 12 causes an interruption to the station load until the defective transformer can be repaired or replaced.

The loads supplied by substations shown in Fig. 13 are not interrupted when a transformer or supply-circuit fault occurs. In these stations the transformer capacity is divided between two units so that if one transformer fails the other carries the entire load. Each transformer preferably has a self-cooled rating equal to about 75 per cent of the substation rating and should be equipped with automatic air-blast as discussed in connection with the substations of Fig. 10.

A high quality of service with minimum equipment is provided by the substation shown in Fig. 13(a). Each transformer is operated as a unit with its associated sub-transmission circuit and has only a disconnecting switch on its high-voltage side. The breaker in the low-voltage leads of the transformer is controlled by directional-over-current relays arranged to trip when current flows from the substation bus toward the transformer. These relays are given a short time setting and operate when a transformer or supply-circuit fault occurs. The breaker is also equipped with overcurrent relays, with a longer time setting, to protect against low-voltage bus faults. When a supply-circuit or transformer fault occurs the associated low-voltage transformer breaker opens. The breaker at the source end of the supply circuit also opens and completely disconnects the circuit and associated transformer from the system.

The substation of Fig. 13(b) provides the same quality

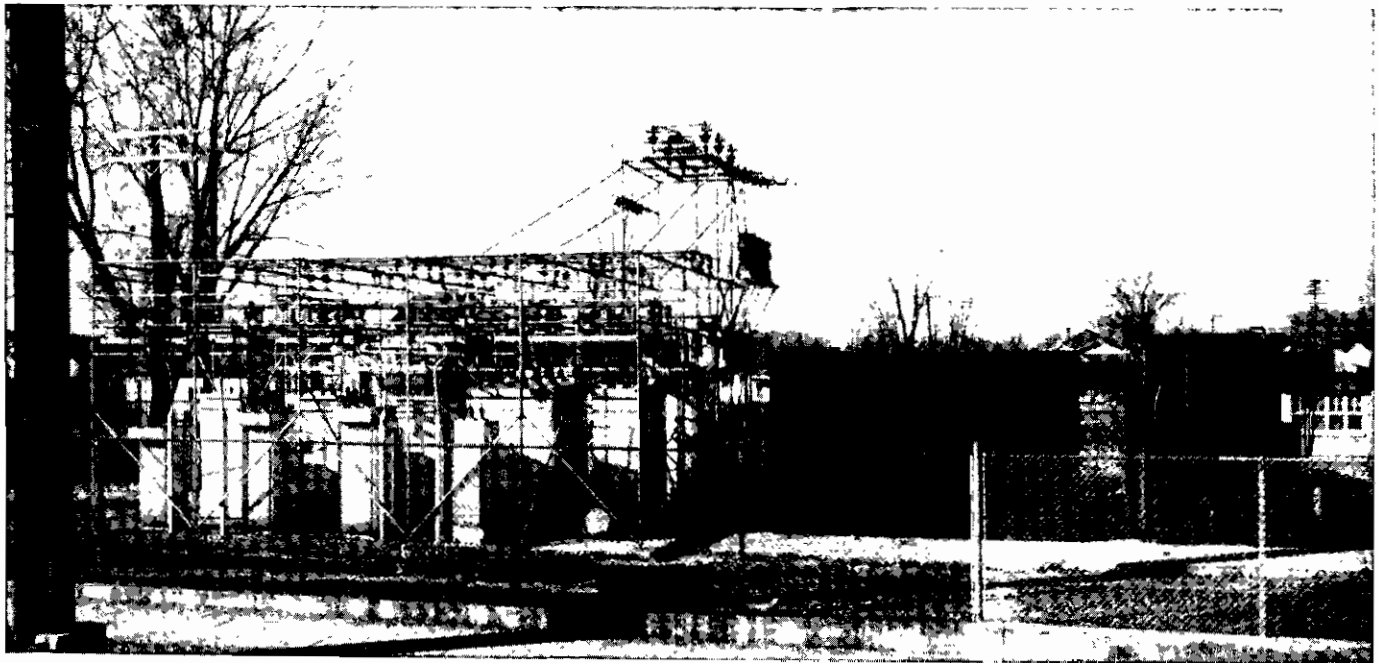

Fig. 14—A 1500 kva open structure substation and a 3000 kva unit substation on a power system in the midwest. High voltage — 13.2 kv; low voltage — 4160 volts.

of service as the station just described, however, both transformers remain in service when a supply-circuit fault occurs. To accomplish this a high-voltage bus and three high-voltage breakers, all of which are normally closed, are required. In addition to maintaining both transformers in service when a supply circuit fault occurs, this substation differs from the station of Fig. 13(a) in that the two supply circuits are tied together through the high-voltage sectionalizing breaker with negligible impedance between them instead of being connected through the impedance of the two substation transformers in series. Such a tie with low impedance is necessary where the two supply circuits are parts of a subtransmission loop, ring, or grid. The two high-voltage transformer breakers are equipped with directional-overcurrent relays to trip in the event of a supply circuit fault. Overcurrent relays, with a longer time setting, or differential relays are used to trip these breakers on a transformer or high-voltage bus fault. The high-voltage bus-sectionalizing breaker is also controlled by overcurrent or differential relays to trip only when a transformer or high-voltage bus fault occurs. The low-voltage transformer breakers are relayed either similar to those of the station of Fig. 13(a) or with overcurrent and differential relays. The relay coordination in this substation, however, is such that each of these breakers trips only on low-voltage bus faults and on faults in its associated transformer and high-voltage bus section. Upon the occurrence of a supply-circuit fault the circuit is disconnected from the substation by the opening of the associated high-voltage transformer breaker. The station load is then carried over the good supply circuit and through both transformers. A transformer fault is cleared by the high-voltage bus-sectionalizing breaker and its associated high- and low-voltage transformer breakers. This leaves the substation load supplied through the good transformer and over its associated supply circuit only.

It may be objectionable to have a subtransmission loop, ring, or grid open on a substation transformer fault as would occur with the station of Fig. 13(b). This can be prevented by using four high-voltage breakers as shown in Fig. 13(c). The two subtransmission breakers at the substation are relayed to trip by means of directional-overcurrent and overcurrent or differential relays to protect against supply circuit and high-voltage bus faults, respectively. Each transformer may have its associated breakers controlled by differential relays to protect against transformer failures. The low-voltage transformer breakers are equipped with overcurrent relays to protect against low-voltage bus faults. A supply circuit fault is cleared from the station by the associated subtransmission breaker at the substation. When a transformer fault occurs its high- and low-voltage breakers open and disconnect the transformer from the system. The substation load is then fed over both supply circuits and through the good transformer.

In all of the distribution substations discussed a low-voltage bus fault interrupts service to all or a part of the substation load for a relatively long time until repairs can be made or the primary feeders can be temporarily connected to a portable substation. This is also true of a high-voltage bus fault in most stations. The likelihood of

such faults in a modern unit substation is remote, and if small substations of 3000 kva or less are used the consequences of these bus faults are minimized. They can be further minimized by the design of the distribution systems primary feeder layout, as discussed later. By the term modern unit substation is meant a complete substation factory built and tested. Such a substation usually consists of one or more three-phase transformers equipped with automatic tap-changing-under-load, the necessary high-voltage disconnecting switches or breakers, and the low-voltage breakers and bus work. The switchgear section or sections, containing all necessary disconnecting switches, buses, circuit breaker, relays, and auxiliaries, are completely metal enclosed and mount on or bolt directly to the associated transformer or transformers. This gives a completely metal-enclosed weatherproof substation consisting of one or more sections that can be readily handled as a unit or in sections and bolted together on the site. Provision is usually made for bringing the subtransmission and primary-feeder circuits into the unit or units underground so as to avoid all overhead structures and congestion of overhead circuits near the station. If desired the smaller unit stations, instead of being installed outdoors, can be constructed for subway service and installed in vaults or manholes underground. Such construction is usually very expensive but at times can be justified because of the difficulty of obtaining a site for the substation in the neighborhood where it should be located. In certain locations it is necessary to enclose the unit substation within an ornamental wall or building, which may have the appearance of a private residence. In such installations a standard outdoor unit substation can be used, or if it is located in a building the switchgear can be of unit indoor cubicle construction with the transformer or transformers bolted directly to it.

In building service reliability into a substation, and particularly into a relatively small station where the magnitude of the outage is not too great, it should be remembered that regardless of how much reliability is built into the substation a fault on a primary feeder energized from the station bus will interrupt an appreciable amount of load. Another thing to remember when selecting the type of distribution substation for a particular job is that the probability of a fault in a subtransmission circuit is much greater than in a substation transformer. Also if the substation is small the amount of load that may be affected by the subtransmission-circuit fault is much greater. Because of these facts a few of the types of distribution substations already discussed will take care of the majority of distribution requirements where relatively small substations are economical. In general small distribution substations promote system flexibility. System studies indicate that such substations usually offer economic advantages when considering the distribution system as a whole.

Sometimes, however, in congested areas with high load densities relatively large substations of about 10 000 kva or larger are economical. Because of the magnitude and the importance of the load involved a high degree of reliability is often built into these stations. These large substations may be similar to some of the types previously discussed, particularly those of Figs. 12 and 13. In view

of the seriousness of a bus fault in such a large substation it is sometimes desirable to use some type of double-bus substation. One such station is shown in Fig. 15. This station is similar in layout and operation to the substation of Fig. 13(c), except for the double-bus feature.

Normally the station is operated with all double-throw disconnecting switches or selector switches in the positions

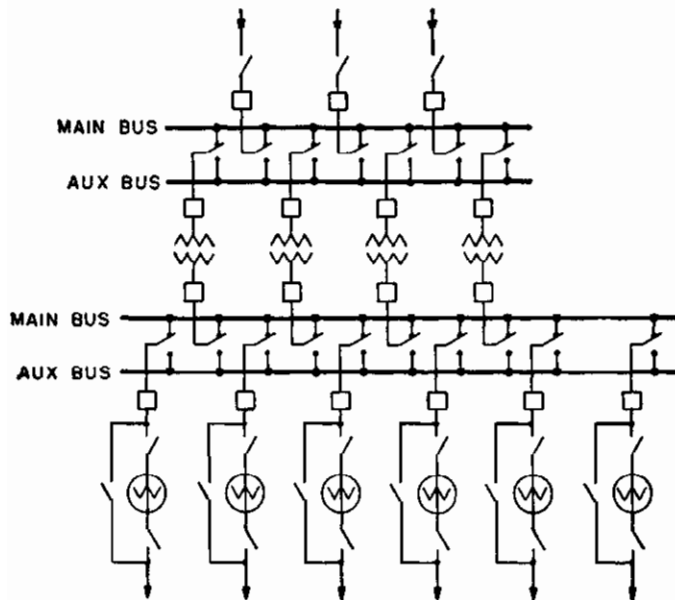

Fig. 15—Distribution substation with high- and low-voltage double bus to permit isolating bus faults.

shown, so that all circuits and transformers are connected to the two main buses. Differential relays associated with the breakers in the subtransmission circuits at the substation and the high-voltage transformer breakers trip all of these breakers when a high-voltage main-bus fault occurs thus dropping the entire station load. Service can be restored quickly to all loads, however, by closing all high-voltage selector switches to their auxiliary-bus positions and then reclosing the high-voltage transformer and supply-circuit breakers. This leaves the station with all breakers in service and complete protection while the defective bus is being repaired. Similarly a fault on the low-voltage main bus is cleared by its differential relays tripping all low-voltage transformer breakers and primary-feeder breakers. The primary-feeder breakers need not be opened if there is no possibility of a back feed over any primary feeder. However, they are usually tripped as a matter of safety. Such a bus fault completely interrupts service to the substation load, but this load can be picked up in a short time by closing all low-voltage selector switches to their auxiliary-bus positions and reclosing the low-voltage transformer breakers and the primary-feeder breakers. A normally closed bus-tie breaker can be used between the two low-voltage buses with half the primary feeders ordinarily connected to each bus. This reduces the amount of load dropped when a low-voltage bus fault occurs by about one half, but it complicates the low-voltage bus relaying.

While bus regulation in the form of automatic tap-

changing-under-load on the substation transformer or transformers is often satisfactory for small substations, individual feeder regulators are usually required on some or all of the primary feeders in the larger substations as shown in Fig. 15. These regulators may replace automatic tap-changing-under-load on the substation transformers. At times, however, it is economical to use the individual feeder regulators only on the feeders where needed to supplement bus regulation.

In a large distribution substation similar to that of Fig. 15, or a less elaborate large substation laid out similar to one of the stations of Fig. 13, the short-circuit current which the primary feeder breakers must interrupt becomes very large. Also as the capacity of such a station increases, the short circuit duty on the primary feeder breakers increases. As the station grows this duty may exceed the interrupting rating of the original feeder breakers. This high short-circuit duty on the primary-feeder breakers means relatively expensive feeder breakers.

A substation which provides substantially the same quality of service and with much lower short-circuit duty on the primary-feeder breakers is shown in Fig. 16. Also the station capacity can be increased indefinitely without increasing the maximum short-circuit current the primary-feeder breakers must interrupt. The marked reduction in short-circuit duty on the primary-feeder breakers follows because each transformer and primary feeder is operated as a unit with all selector switches normally in the positions shown. Since the transformers are not paralleled on their low-voltage sides the short-circuit current which each primary-feeder breaker can be called upon to interrupt is limited by the impedance of its associated transformer.

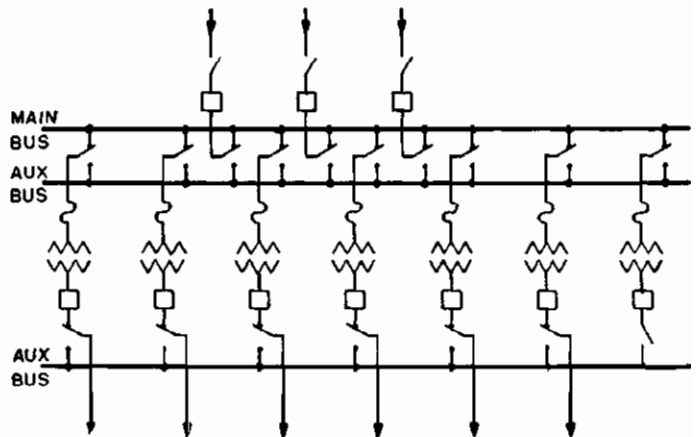

Fig. 16—Distribution substation with high-voltage double bus and low-voltage auxiliary bus and individual transformation in each primary feeder resulting in relatively low interrupting duty on feeder breakers.

Each transformer is relatively small because its capacity is equal to that of its associated feeder, which will usually be from 1000 to 2000 kva. To prevent a transformer fault interrupting service to its associated feeder for a relatively long time pending repairs or replacement an auxiliary low-voltage bus is provided and arrangements are made so that any one primary feeder can be switched from its associated transformer to the auxiliary bus. The auxiliary low-volt-

age bus is energized through a spare transformer shown on the right in Fig. 16. This transformer is ordinarily of the same capacity as each of the feeder transformers, because such a station is usually designed on the basis that only one primary feeder is connected to the auxiliary low-voltage bus at any one time. The saving in low-voltage breaker cost may or may not be offset by the increased transformer cost. The transformer cost is increased primarily because the transformer capacity is made up of a relatively large number of small units. Also since the transformers are not paralleled on their load sides advantage cannot be taken of the diversity between primary feeders to reduce the station transformer capacity as is done in a substation such as that of Fig. 15. This tendency to require more transformer capacity is usually more than offset, however, by the much smaller spare transformer capacity required. The relatively large number of transformers required in such a station often would result in excessive high-voltage transformer breaker cost. For this reason high-voltage fuses or protective links as shown in Fig. 16 are ordinarily used with each small transformer. Except for this substitution of fuses for breakers the high-voltage side of this station is similar to that of the station in Fig. 15. Individual feeder regulation can be and usually is provided in a station of this type by means of automatic tap-changing-under-load on each transformer.

The feature of unit operation of each primary feeder with its own relatively small transformer and one similar spare transformer for all feeders can be applied to a sub-

station having only a single high-voltage bus such as the station of Fig. 13(c) as well as to a double high-voltage bus station. Such a substation, unlike most large stations, is very flexible in that its capacity can be increased economically in relatively small steps and thus kept close at all times to that required to serve its load.

Primary Feeders—As has already been explained a radial type of distribution system usually is not radial from the bulk power source or sources to the low-voltage buses of the distribution substations. The primary feeders from the substation low-voltage buses to the primaries of the distribution transformers, however, are in all cases radial circuits, and the system is usually radial from the substation low voltage buses to the consumers' services. The radial primary feeders are principally responsible for the lack of service continuity provided by most radial distribution systems. A fault on any one of the radial primary-feeder circuits results in an outage to many consumers. With the radial type of distribution system these service interruptions cannot be prevented. The amount of load dropped when certain primary-feeder faults occur can be decreased, however, and service often can be restored promptly to all or a part of the consumers affected.

A simple form of primary feeder is shown in Fig. 17(a). The main primary feeder branches into several subfeeders which in turn divide into a number of primary laterals so as to reach all of the distribution transformers in the area served by the primary feeder. The main feeder and subfeeders are ordinarily three-phase three- or four-wire cir-

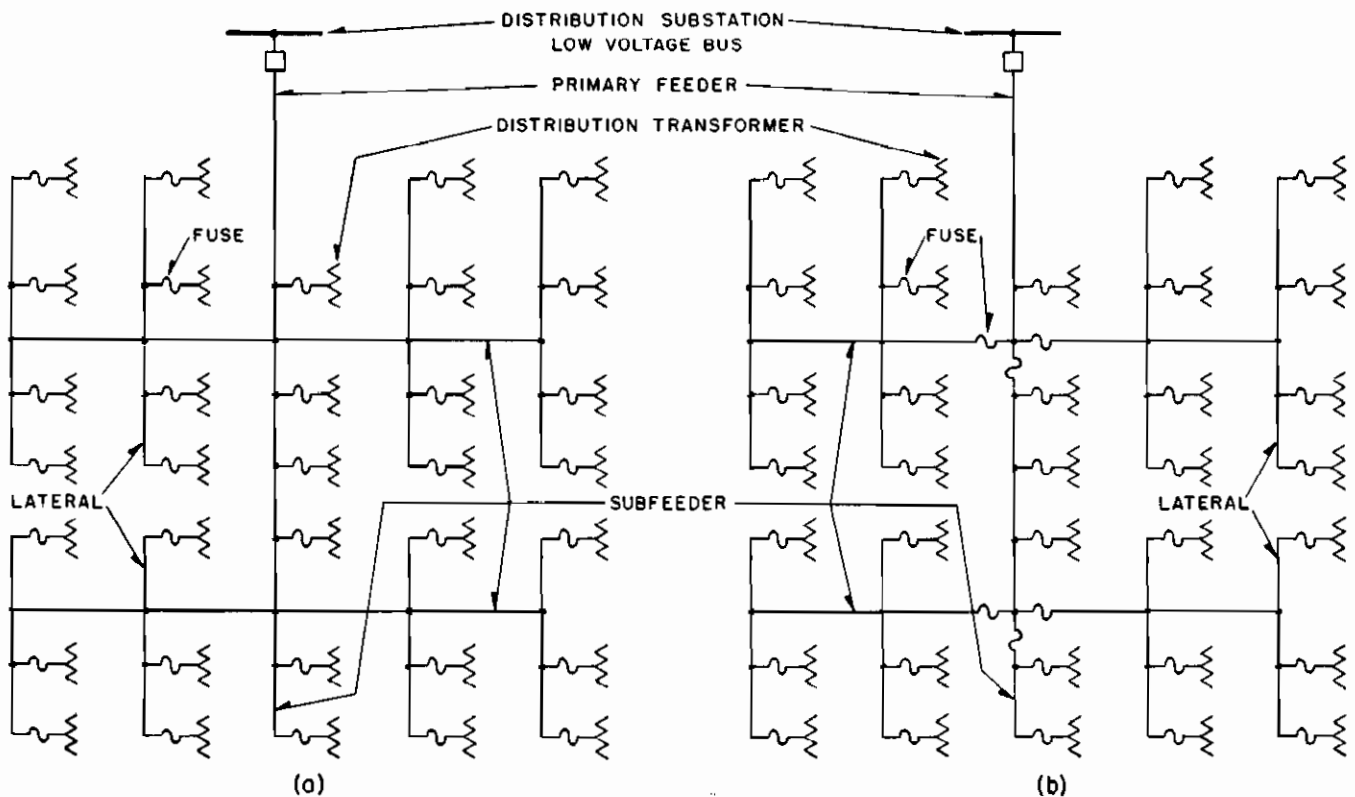

Fig. 17—Simple form of radial primary feeder.

(a) Without subfeeder fuses.

(b) With subfeeder fuses to reduce the number of consumers affected by subfeeder faults.

cuits and the primary laterals can be either three-phase or single-phase circuits. Most primary laterals are usually single-phase circuits. The distribution transformers are connected to the various parts of the primary feeder through primary fuses or fused cutouts. These transformers are both three-phase banks and single-phase; however, the great majority of them are ordinarily single-phase.

When a fault occurs anywhere on the primary feeder of Fig. 17 (a) the primary-feeder breaker at the substation trips and deenergizes all loads connected to the feeder. Where the feeder is of overhead open-wire construction the fault may be temporary, such as an insulator flashover or an arc between conductors which clears itself when the primary-feeder breaker trips. In such cases when the feeder breaker is reclosed it remains closed. To restore service quickly when primary-feeder breakers trip on temporary faults these breakers, on overhead open-wire feeders, are usually equipped with automatic reclosing relays. The reclosing relaying ordinarily provides for two or three reclosures at intervals of several seconds. If the fault has not cleared itself after the second or third reclosure it is in nearly all cases of a permanent nature and the breaker trips a third or fourth time and is locked open. Most temporary faults will clear themselves upon the first opening of the primary-feeder breaker, and to restore service as quickly as possible in these cases the first reclosure is often made without any time delay. Experience indicates that in many cases 80 per cent or more of the faults on open-wire primary feeders are temporary. This means in the majority of cases service can be quickly restored when faults occur on such feeders by making the primary-feeder breakers automatic reclosing. If the fault on the primary feeder of Fig. 17 (a) is permanent, all of the feeder load is without service until the fault can be located and repairs made. On an overhead open-wire circuit that does not cover too large an area and contain too many miles of circuit the fault can usually be located and repaired in a few hours.

If the conductors of the primary feeder of Fig. 17 (a) are cables most faults on the feeder will be permanent. Because of this an automatic-reclosing feeder breaker is rarely used on a cable feeder. The likelihood of faults on such a feeder are much less than on an overhead open-wire feeder; however, the time required to locate and repair a cable-feeder fault will be much greater. This means there will be fewer outages on such a feeder than on an open-wire feeder but all customers will be without service for a much longer time when a fault occurs. It will often require a half day or more to locate and repair such a fault. To reduce the number of consumers affected by many of these long service interruptions the primary feeder and its branches or subfeeders are often fused as shown in Fig. 17 (b). When a fault occurs on a primary lateral or subfeeder the associated subfeeder fuse blows and disconnects the faulty section from the remainder of the primary feeder. This confines the outage to only a portion of the feeder load and may decrease the duration of the outage somewhat because less time may be required to locate the fault.

In applying feeder and branch or subfeeder fuses care must be taken that they are properly coordinated with

the primary-feeder breaker, the distribution transformer fuses, and with each other so that the first fuse on the supply side of the fault and only that fuse will blow. This means that on any current flowing to a fault the fuse adjacent to the fault must blow before any other fuse that carries the fault current will be damaged. For any possible value of fault current all fuses must have a blowing time less than the tripping time of the primary-feeder breaker. Where the percentage of permanent faults is large, as in the case of cable feeders, sectionalizing the feeder with fuses will improve the quality of service rendered. On feeders where most faults are temporary and where automatic-reclosing breakers are used, such as overhead open-wire feeders, the use of feeder-sectionaling fuses is questionable. This is because many fuse blowings will occur on temporary faults and cause an outage to a portion of the feeder load until a complaint is received and the fuse can be replaced. If sectionalizing fuses are not used the entire feeder load will be dropped on these temporary faults, but service will be restored to all loads in a few seconds by the reclosing of the feeder breaker.

The objection to fusing these overhead feeders can be overcome, at least to a considerable extent, by using two- or three-shot repeater fuses. When repeater fuses are used they must be closely supervised, otherwise they may be left in operation with only one fuse unblown. Then when another temporary fault occurs in the section an outage to the load fed from that section will occur until the fuse is replaced just as when using single fuses.

Perhaps a better method of overcoming the difficulty of having sectionalizing fuses blow on temporary faults is to use single fuses and relay the primary-feeder breaker so that it trips substantially instantly on all feeder faults. Thus when a fault occurs anywhere on the feeder the feeder breaker trips before any sectionalizing fuse has time to blow. This first tripping of the breaker modifies its relay control so that its second and subsequent trippings take place in the usual way only after some time delay. When the breaker recloses the first time it remains closed if the fault has cleared itself, and if not, fault current flows long enough to blow the fuse adjacent to the fault on the supply side. Thus no fuse blowings occur on most temporary faults because they clear themselves on the first deenergization of the feeder.

Permanent faults and the few temporary faults that do not clear themselves when the feeder is deenergized the first time are cleared by the sectionalizing fuses, and service can be restored to the affected section or sections of the feeder only after repairs, if any, are made and the fuses are replaced. This entire discussion of primary feeder sectionalizing has been on the basis of using sectionalizing fuses. Fuses are the most generally used sectionalizing devices because of their relatively low cost. At times, however, circuit breakers, usually reclosing breakers, are used for this purpose.

The effectiveness of sectionalizing fuses in reducing the extent of the outage when a primary-feeder fault of a permanent nature occurs depends upon the location of the fault. The fault may be so located that two or more sections of the feeder or the entire feeder will be deenergized until the fault is located and repairs are made.

To restore service quickly to unfaulted sections of a feeder, which are deenergized along with the faulty section, provisions are sometimes made to permit temporarily switching such sections over to an adjacent primary feeder or feeders. One method of doing this is shown in Fig. 18. Sectionalizing switches are used in conjunction with the sectionalizing fuses shown in Fig. 17 (b), or the fuses can be omitted as in Fig. 17 (a) and only the switches used at the feeder sectionalizing points. By the use of these sectionalizing switches and the four tie switches shown all of the good sections of the central primary feed can be supplied over the two adjacent feeders, and the faulty section of the central feeder can be completely isolated for repairs.

The sectionalizing and tie switches can be of the disconnecting type. If they are care should be taken not to interrupt load current with them. When the feeder, or a portion of it, is deenergized as the result of a fault the faulty section is first determined. The deenergized sections are then disconnected from each other by opening their associated sectionalizing switches. The good sections are reenergized from the adjacent feeders by closing the tie switches. After the fault is repaired the faulty section is reenergized by closing the feeder breaker or replacing the blown fuse and closing its associated sectionalizing switch, depending upon the location of the fault. Then all open sectionalizing switches should be closed and the tie switches opened after this is done. By following this procedure no switches are required to open load current. However, the tie switches are required to open parallel paths over which current flows.

This procedure for switching loads between feeders has the advantage of not interrupting service to the loads on the good feeder sections when they are reconnected to their normal feeder. At the time of reconnection, the feeders between which the loads are being switched are paralleled for a short time. This is usually not objectionable, however, should a fault occur on either feeder at the time they are paralleled both feeders will be deenergized if sectionalizing fuses are not used, and a section of the unfaulted feeder will probably be deenergized even if fuses are used. If it is felt that this short-time paralleling of feeders is objectionable the tie switches must be capable of breaking load current.

To avoid paralleling the feeders when reconnecting good feeder sections to their normal circuit their associated tie switches must be opened and their loads deenergized before their sectionalizing switches are closed. Regardless of which switching procedure is used, it is safer to employ load-break switches for both sectionalizing and tie switches to eliminate the danger of opening a switch by mistake when load current is flowing through it. If primary feeders are arranged so that their loads can be switched from one feeder to another under emergency conditions, sufficient spare capacity must be built into each feeder so that it can carry any load which can be connected to it. When a feeder is carrying all or a part of the load of a defective feeder it is usually advisable for economic reason to allow somewhat greater voltage drop over it than is satisfactory under normal operating conditions.

Many interrelated factors affect the choice of rating for

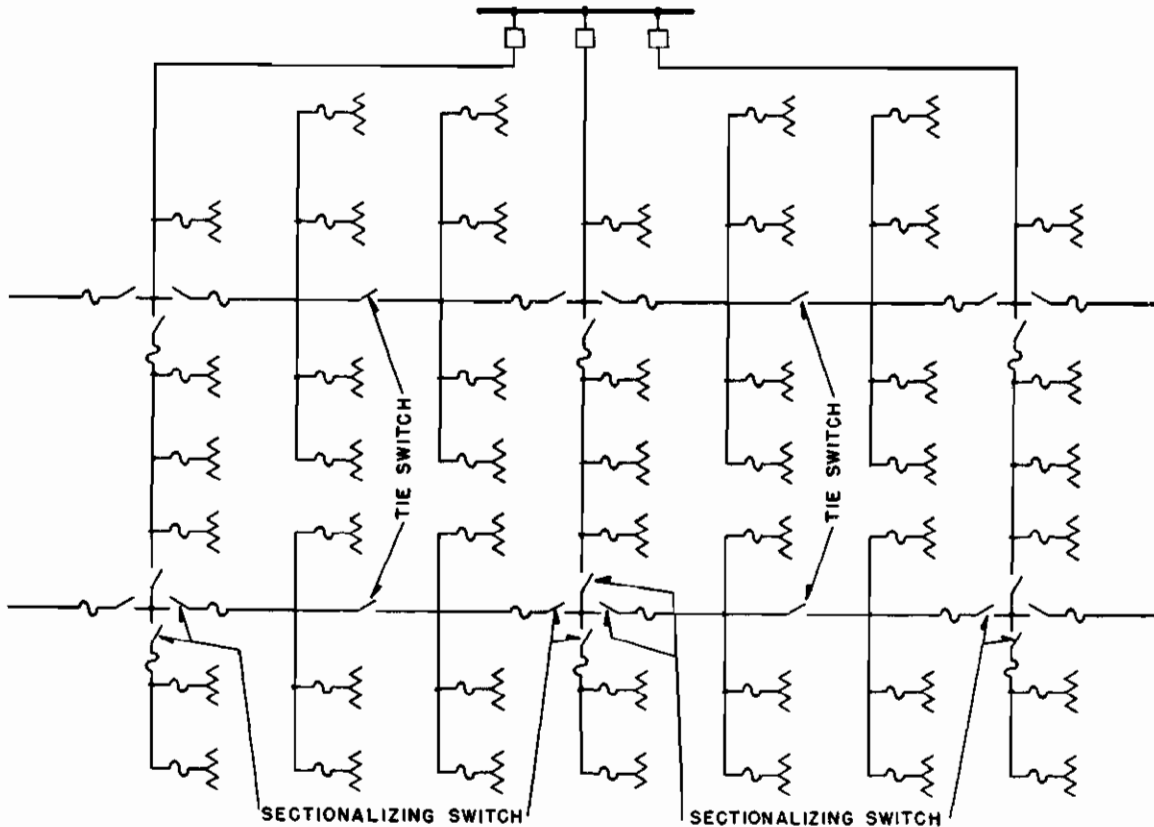

Fig. 18—Simple form of radial primary feeder with tie and sectionalizing switches to provide for quick restoration of service to consumers on unfaulted feeder sections.

a primary feeder. Some of the more important factors are the nature, density, and rate of growth of the load; the necessity for providing spare capacity for emergency operation; the type and cost of the circuit construction which must be used; the design and capacity of the associated substation; the type of regulating equipment necessary; and the quality of service required. Some kinds of loads, such as welders and arc furnaces, may have to be segregated to a separate feeder or feeders to prevent their adversely affecting other loads. The amount of such load in the area and the voltage requirements at the load influence the rating of the feeder or feeders. The rate of load growth and the provision for emergency operation affect the amount of spare capacity a feeder should have. In areas of heavy load density it will usually be economical to use larger capacity feeders than in the lighter load density areas. The feeders are shorter, the circuits are usually of expensive underground cable construction with low reactance per unit length, and the size and design of the substations are often such that higher interrupting capacity and consequently more expensive feeder breakers are required. The nature and density of the load together with the substation size also influence the type of regulating equipment selected. If individual feeder regulators are necessary larger feeders are usually chosen, for economic reasons, than when bus regulation is satisfactory. Relatively small substations, usually found in medium and light load density areas, are ordinarily accompanied by smaller feeders because of the lower cost of feeder breakers, the absence of individual feeder regulators, and the lower cost and higher reactance per unit length of circuit. The quality of service, in addition to some of the other factors mentioned, will help determine the permissible feeder voltage difference between the first and last transformers on the feeder, or between the first and last transformers on the group of feeders from a substation if bus regulation is used. The amount of load that should be dependent on any one primary feeder and interrupted when a feeder fault occurs is influenced primarily by the necessary quality of service. The various interrelated factors mentioned and others that affect the proper rating for a primary feeder, can in general be boiled down to two major factors, namely cost and quality of service. Cost considerations most often dictate the use of a relatively large feeder, and a high quality of service calls for a small feeder. After all factors have been carefully weighed to determine the economics and service requirements the feeder capacity should be made as small as can be economically justified. Primary feeders ordinarily vary in rating from about 500 to 2500 kva with most ranging between 750 and 1500 kva.

The permissible voltage drop in a primary feeder is an important factor in its design. When a voltage regulator is used on the feeder the voltage at the primary of the distribution transformer nearest the substation low-voltage bus is maintained constant within about plus or minus one per cent, or if overcompensation is used this voltage is increased somewhat as the flow of load current over the feeder increases. In order to provide satisfactory voltage conditions at all consumers the voltage maintained at the above mentioned point must be such that at times of minimum load no consumer receives a higher than satis-

factory voltage. Also at times of maximum load the voltage drop from this point on the primary feeder to the consumers meter where the lowest voltage occurs must be such that this lowest voltage is not too low to be satisfactory. This total voltage drop should be divided among the primary feeder, the distribution transformer, the secondary circuit, and service so as to obtain the lowest overall cost for these portions of the distribution system. The permissible voltage drop on the primary feeder between the first and last distribution transformers is usually about 2 per cent or less at the time of peak load. This figure will of course be affected somewhat by the type of primary and secondary construction used and by the permissible load voltage variation. If the voltage at the first transformer on the primary feeder can be boosted by means of over-compensation as the load on the feeder increases the permissible voltage drop is increased somewhat. The amount of overcompensation or boost in voltage permissible during maximum load without overvoltage at some consumers during light loads depends upon the uniformity of the loading of the distribution transformers. The more uniform the load on these transformers the more the over-compensation that can safely be used. When a primary feeder is loaded to the point where the permissible voltage drop has been reached further load can be added, if the current carrying capacity of the feeder has not been reached, by installing a voltage booster or another feeder regulator in the feeder just on the supply side of the point where the voltage drop becomes excessive when the additional load is being carried. The consideration of feeder voltage drop when the feeder is supplied from a bus regulated substation is similar to that just described, except that all primary feeders connected to the station bus must be considered as a unit. The allowable voltage drop on any feeder of the group is determined by the voltage difference between the high- and low-voltage points on the group of feeders, where distribution transformers are connected, which will just give satisfactory voltage at all consumers at the time of peak load.

The trend in the power-factor of loads in residential areas has been downward for some years. This is largely because of the increasing use of motored appliances. The lower power-factor loads on the parts of distribution systems serving these areas has aggravated the voltage regulation problem. Shunt capacitors are used frequently to improve voltage conditions on distribution systems. This improves the power-factor and thus reduces the voltage drops and currents in the parts of a distribution system between the capacitors and the bulk-power sources. To get the maximum advantage from shunt capacitors they should be connected to the system as near the loads as possible. For economic reasons they are usually connected to the primary feeders through primary fuses or fused cutouts. Whether the capacitors are connected to the feeder proper or to its subfeeders or laterals depends upon the load and voltage conditions on the feeder. When applying capacitors their ratings should be such that objectionable overvoltages do not occur, at light load periods, because of the voltage rise produced by the capacitor currents. To get the desired results from capacitors in certain installations it is necessary to connect them to the

system through breakers and arrange to automatically disconnect all or part of them at times of light load.

Series capacitors are also used on distribution feeders to improve voltage conditions. However, they do not reduce the currents in the system and thus permit a saving in system capacity as do shunt capacitors. The usual application of series capacitors is in relatively high reactance circuits, supplying fluctuating loads, to reduce abrupt voltage changes. The capacitors are selected so their capacitive reactance about cancels the inductive reactance of the line. They are installed on the supply side of the location where the improvement in voltage is desired.

Distribution Transformers, Secondaries, and Service.—The distribution transformers step down from the distribution or primary feeder voltage to the utilization

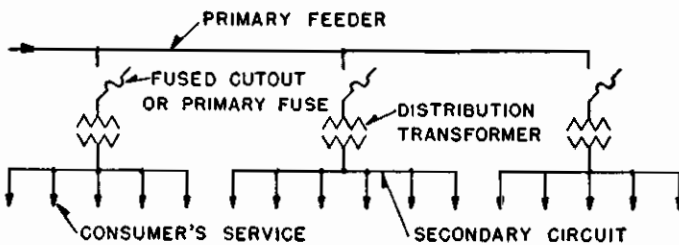

Fig. 19.—Typical method of connecting distribution transformers between primary feeders and radial secondary circuits.

voltage. They are connected to the primary feeder, subfeeders, and laterals through primary fuses or fused cutouts as shown in Fig. 19. The primary fuse disconnects its associated distribution transformer from the primary feeder when a transformer fault or low-impedance secondary-circuit fault occurs. The blowing of the primary fuse prevents an interruption of service to other loads supplied over the feeder, but interrupts service to all consumers supplied through its transformer. Fused cutouts shown in Fig. 19, which are normally closed, provide a convenient means for disconnecting small distribution transformers for inspection and maintenance.

Satisfactory overload protection of a distribution transformer cannot be obtained with a primary fuse, because of the difference in the shape of its current-time curve and the shape of the safe current-time curve of a distribution transformer. The shapes of the two curves are such that if a small enough fuse is used to provide complete overload protection for the transformer much valuable transformer overload capacity is lost, because the fuse blows and prevents its being used. Such a small fuse also frequently blows unnecessarily on surge currents. Because of this a primary fuse should be selected on the basis of providing short-circuit protection only and its minimum blowing current should usually exceed 200 per cent of the full load current of its associated transformer.

Distribution transformers connected to overhead open-wire feeders are often subjected to severe lightning disturbances. To minimize insulation breakdown and transformer failures from lightning, lightning arresters are ordinarily used with these transformers. The protection of distribution transformers from lightning is discussed in Chapter 14.

The secondary leads of a distribution transformer are

usually solidly connected to radial secondary circuits from which the consumers services are tapped as shown in Fig. 19. This means that no protection is provided the transformer against overloads and high-impedance faults on its secondary circuits. Relatively few distribution transformers are burned out by overloads. This is largely because distribution transformers are applied so that full advantage is rarely taken of their overload capacity. Another factor contributing to the small number of distribution transformer failures by overloads is the frequent load checks often made and the corrective measures taken before dangerous overloads occur. Probably high impedance faults on their secondary circuits cause more distribution transformer failures than do overloads. This is certainly true in localities where bad tree conditions exist.

Fuses in the secondary leads of distribution transformers are little if any more effective in preventing transformer burnouts than are primary fuses and for the same reasons. The proper way to obtain satisfactory protection for a distribution transformer against overloads and high-impedance faults is by means of a breaker in the secondary leads of the transformer. The tripping curve of this breaker must be properly coordinated with safe current-time curve of the transformer. The primary fuse must be coordinated with the secondary breaker so that the breaker trips on any current that can pass through it before the fuse is damaged. Faults on a consumer's service connection from the secondary circuit to the service switch are so rare that the use of a secondary fuse, where the service connection taps onto the secondary circuit, cannot be economically justified except in unusual cases such as large services from underground secondaries.

As has been previously pointed out the allowable voltage drop from the point where the first distribution transformer connects to the primary feeder to the service switch of the last consumer supplied over the feeder should be economically divided among the primary feeder, the distribution transformer, the secondary circuit, and the consumer's service connection. Assuming a maximum voltage variation of about 10 per cent at any consumer's service switch the division of this drop among the various parts of the system, at times of full load, may be about 2 per cent in the primary feeder between the first and last transformers, 2.5 per cent in the distribution transformer, 3 per cent in the secondary circuit, and 0.5 per cent in the consumer's service connection. The fact that the voltage at the primary of the first distribution transformer cannot ordinarily be maintained exactly accounts for the other 2 per cent. While these figures are typical for overhead systems supplying residential loads, they can be expected to differ considerably on underground systems where cable circuits and large distribution transformers are used or where industrial and commercial loads are supplied. The economic size of distribution transformer and secondary-circuit combination for any uniform load density and type of construction at any particular market prices can readily be determined once the total allowable voltage drop in these two parts of the system is determined. If the transformer is too large the secondary circuit cost and total cost is excessive, and if the transformer is too small the transformer cost and total cost is too large.

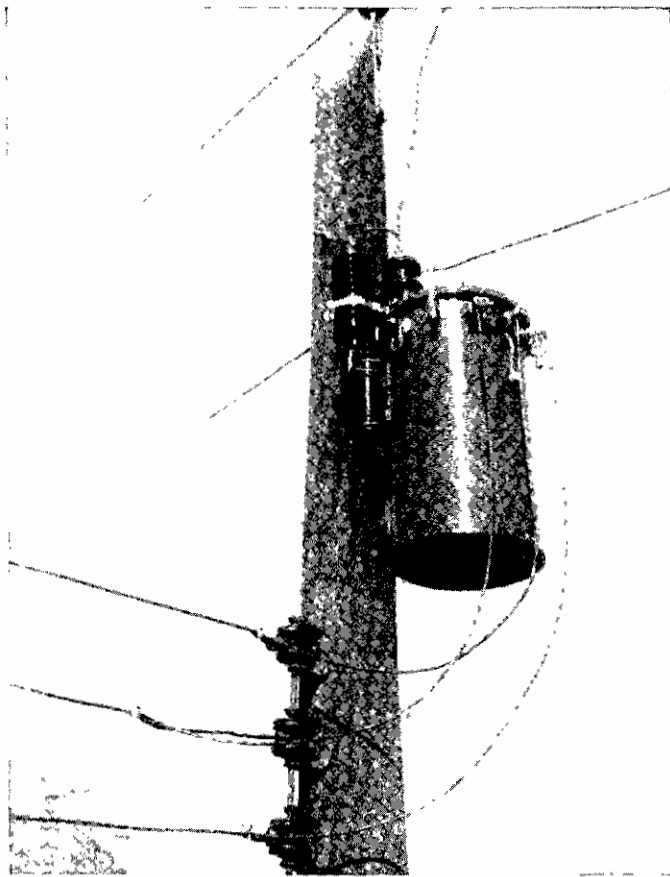

Fig. 20—Pole mounted, 5 kva, single phase, 60 cycle distribution transformer with single cover mounted high-voltage bushing—High voltage—7200 volts; low voltage—120/240 volts.

As in any other part of the distribution system, load change or load growth must be considered and provided for in the distribution transformers and secondary circuits. Also, as with other parts of the distribution system the distribution transformers and secondary circuits are not installed to serve only the loads existing at the time of their installation but some future loads as well. It is not economical to make too much allowance for growth, however. When a distribution transformer becomes dangerously overloaded it can be replaced by one of the next larger size if the current-carrying capacity of the secondary circuit and the overall voltage regulation permit. If not, another transformer of about the same size can be installed between the overloaded transformer and the one adjacent to it. When this is done load is removed from the overloaded transformer by connecting a part of its secondary circuit and associated load to the new transformer. This also reduces the load on the secondary circuit of the overloaded transformer and improves the overall voltage regulation. If the load in the area is reasonably uniform transformers may have to be installed on both sides of the overloaded transformer in a relatively short time to maintain satisfactory voltage conditions and prevent overloading a part of the secondary circuit. The same result can be obtained, however, by installing one new transformer and moving the overloaded transformer so that it feeds into the center of its shortened secondary circuit.

With the distribution transformers and secondary circuits arranged as shown in Fig. 19 any one load is supplied through only one transformer and in only one direction over the secondary circuit. Because of this a suddenly applied load, such as the starting of a motor, on a consumer's service can cause objectionable light flicker on other consumers' services fed from the same transformer. The increasing use in residential areas of motor-driven appliances, such as washers, refrigerators, forced-air heating systems, and air-conditioning equipment, is resulting in a considerable number of light-flicker complaints. In some areas light flicker and not voltage regulation may be the determining factor in the size and arrangement of transformers and secondary circuits. The banking of distribution transformers is usually the best and most economical means of improving or eliminating light flicker.

The term banking transformers means paralleling on the secondary side a number of transformers all of which are connected to the same primary circuit as shown in Fig. 21. The secondary circuit arrangement in a banked transformer layout can take the form shown in Fig. 21, or it may be a loop or grid similar to that used in a secondary network system. Because of this similarity in secondary-circuit arrangements a banked-transformer layout is sometimes incorrectly referred to as a secondary network system. Banked transformers, because they are connected to and supplied over a single radial-primary feeder, are a form of radial distribution system; whereas a secondary network loop or grid is supplied over two or more primary feeders which results in much greater service reliability.

Banking of distribution transformers is not new and has been used on a number of systems for many years. The

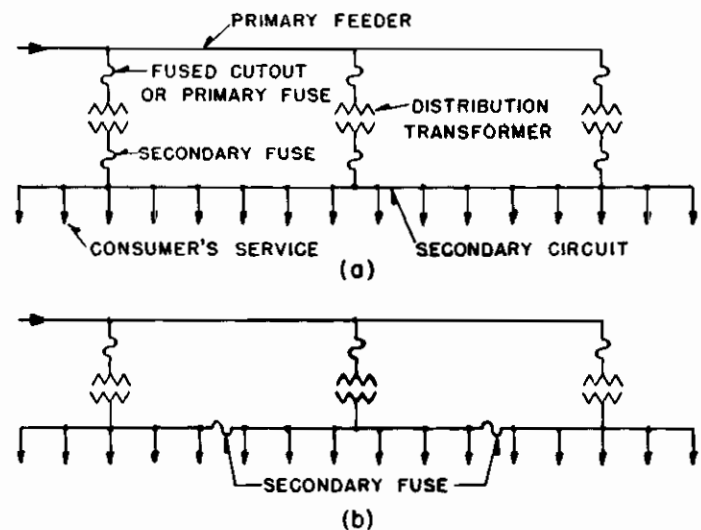

Fig. 21—Typical methods of banking transformers supplied by the same radial primary feeder.

conversion from the usual radial secondary circuit arrangement of Fig. 19 to the banked-transformer arrangement of Fig. 21 can usually be made simply and cheaply by closing the gaps between the radial secondaries of a number of the transformers associated with the same primary feeder and installing the proper primary and secondary fuses.

Two major forms of protection have been used when banking distribution transformers. The arrangement shown in Fig. 21 (a) is probably the oldest and most common. The distribution transformers are connected to their primary feeder through primary fuses or fused cut-outs. These fuses should blow only on a fault in their associated transformer. All transformers are connected to the common secondary circuit through secondary fuses. The purpose of these fuses is to disconnect a faulty transformer from the secondary circuit. The size of the secondary fuse must be such that it will blow on a primary fault between its transformer and the associated primary fuse. Faults on the secondary circuit are normally expected to burn themselves clear. To prevent frequent blowing of secondary fuses on secondary-circuit faults these fuses should have relatively long blowing times on all fault currents. Their blowing times should not be so long, however, as not to provide some degree of protection to their transformers against secondary faults that do not burn clear or require an unusually long time to do so. As previously stated secondary fuses cannot be expected to protect transformers satisfactorily against overloads and high-impedance secondary faults. The use of a secondary breaker having the proper current-time characteristics is preferable to secondary fuses when banking transformers as shown in Fig. 21 (a) because greater protection is afforded the transformer against overloads and high-impedance faults. The secondary fuses or breakers should open in less time than the primary fuses on any possible current so as to prevent the blowing of primary fuses on a secondary fault.

A transformer fault is cleared by the transformer's primary and secondary fuses without any interruption to service. Most secondary faults will clear themselves quickly. However, when a secondary fault hangs on for a long time or fails to clear altogether several or all of the secondary fuses blow and some of the transformers may be burned out. Experience indicates that, where a careful study of the fault currents to be expected is made and the primary and secondary fuses are properly selected, this method of banking operates with very little trouble. Occasionally a secondary-circuit fault causes the blowing of all secondary fuses or the blowing of some secondary fuses and the burning out of a few transformers. When this happens the extent of the service interruption is much greater than when radial secondary circuits are used.

The banking arrangement shown in Fig. 21 (b) is preferable to that just described because there is no danger of a complete service interruption to the banked area by a secondary fault. It should be remembered, however, in considering either of these arrangements that the possibility of a secondary fault is considerably less than that of a primary fault and that secondary faults are ordinarily infrequent. In this second arrangement the distribution transformers are connected to the primary feeder through primary fuses just as in the first arrangement and for the same reason. The transformers are connected solidly to the secondary circuit and the secondary circuit is sectionalized between transformers by secondary fuses. These fuses are selected so that for any secondary-circuit fault they will blow quicker than any primary fuse. When a transformer fails it is cleared from the system by its

primary fuse and the adjacent secondary fuses on each side of it. Thus, unlike the previous arrangement, a transformer fault results in a service interruption to those consumers associated with the faulted transformer. A secondary-circuit fault is usually burned clear; however, if the fault persists for an unusually long time it is cleared by the secondary fuses next to the faulty section and the primary fuse associated with the transformer connected to the faulty section. The secondary fuses are usually selected so that they operate even on a high-impedance fault, but the primary fuses are not for the reason previously discussed in connection with the radial-secondary circuits. Thus even when a high-impedance fault occurs and hangs on, the secondary fuses adjacent to the faulty section blow and prevent interrupting service on the good secondary sections. The transformer associated with the faulty section in this case, however, will be burned out. In order to prevent this a secondary breaker whose current-time curve is coordinated with the safe current-time curve of the transformer can be used in the secondary leads of the transformer. When such a breaker is used the secondary fuses must be selected so that their blowing times for all fault currents are less than the tripping times of the breakers.

Normally the two banking arrangements function alike. They reduce or eliminate light flicker and improve voltage regulation or permit reduction in the amount of transformer capacity necessary as compared with radial-secondary circuits. This improvement in voltage regulation or reduction in transformer capacity is the result of tying several radial-secondary circuits together and thus taking advantage of the diversity among a number of groups of consumers. A considerable increase in the use of banked transformers can be expected in the future because these advantages often can be obtained at no increase in cost or a saving over the usual radial secondary-circuit arrangement.

2. The Loop System

The loop type of distribution system is used most frequently to supply bulk loads, such as small industrial plants and medium or large commercial buildings, where continuity of service is of considerable importance. The subtransmission circuits of the loop system should be parallel or loop circuits or a subtransmission grid as shown in Figs. 5 and 6. These subtransmission circuits should supply a distribution substation or substations similar to those of Figs. 13, 15, or 16. The reason for this is that as much or more reliability should be built into the system from the low-voltage bus of the distribution substation back to the bulk power source or sources as is provided by the loop-primary feeders shown in Fig. 22. The use in a loop system of a radial-subtransmission circuit or circuits and a distribution substation or substations, which may not provide good service continuity, does not give a well coordinated system. This is because a fault on a subtransmission circuit or in a distribution substation transformer results in an interruption of service to the loads supplied over the more reliable loop-primary feeders. The subtransmission circuits and distribution substations are often common to both radial- and loop-type distribution systems.

One of the most common forms of loop-primary feeder for supplying bulk industrial and commercial loads is shown in Fig. 22 (a). Each end of the loop-primary feeder is connected to the distribution substation low-voltage bus through a primary-feeder breaker. The feeder is run or looped through its load area and small industrial or secondary substations are connected to the loop feeder usually

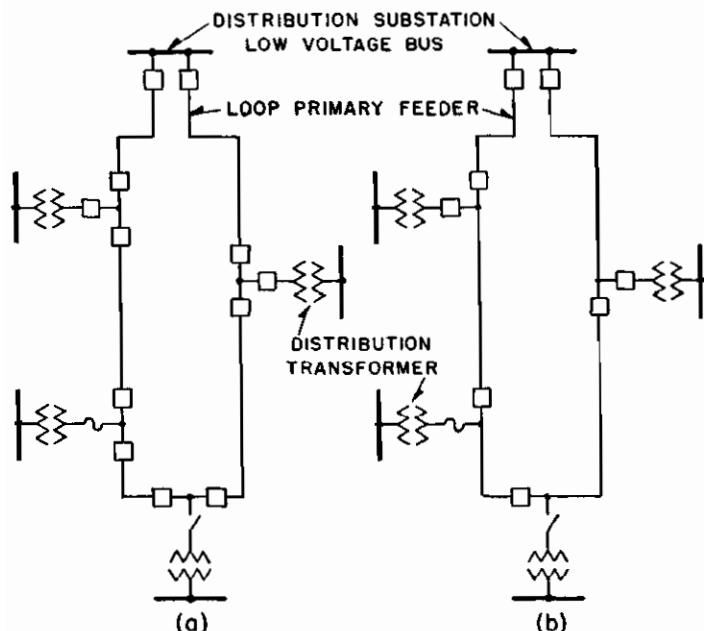

Fig. 22—Two frequently used forms of the loop primary feeder.

- (a) Two sectionizing breakers per secondary substation to isolate a faulted loop section without interrupting service to any load.
- (b) One sectionizing breaker per secondary substation for use where interrupting one load when a loop section fault occurs can be tolerated.

through circuit breakers or fuses in the primary leads of the substation transformers as shown. These transformers, which step down from the distribution to the utilization voltage, are ordinarily relatively large distribution transformers. Because these secondary substations are usually considerably smaller than a distribution substation only one three-phase or one bank of single-phase transformers is used ordinarily as shown in Figs. 12 (a) and (b). In these secondary substations the low-voltage feeders are operated at a utilization voltage of 600 volts or below and they are commonly controlled by air circuit breakers. These secondary feeders are usually radial circuits that run directly to large motors, to power panels, and to lighting panels or small lighting transformers.

The loop-primary feeder is sectionalized by a circuit breaker on each side of the points where secondary substations are connected to it. The two primary-feeder breakers and the sectionizing breakers associated with the loop feeder are ordinarily controlled by directional-overcurrent relays or by pilot-wire relays. Pilot-wire relaying is used where the number of secondary substations connected to the loop is such that selective timing cannot be obtained with directional-overcurrent relays.

With this loop primary feeder arrangement a fault on

any section of the loop is cleared by the circuit breakers at the two ends of the faulty section and service is not interrupted to any secondary substation. As a feeder fault can occur in one of the sections adjacent to the distribution substation bus the entire feeder load may have to be fed in one direction over either end section of the feeder until repairs are made. Sufficient spare capacity must be built into the loop feeder to permit operating with either end section out of service without excessive voltage drop or overheating of the feeder. A fault in a secondary substation transformer is cleared by the circuit breaker or fuse in its primary leads and the loop feeder remains intact. If no transformer primary breaker or fuse is used such a transformer fault must be cleared by tripping the two sectionalizing breakers adjacent to the faulty transformer. In this case the loop is opened and must remain open until the defective transformer is disconnected from the loop.

Obviously a transformer fault in a single-transformer secondary substation results in an interruption of service to all loads fed from the station. Such a fault is much less likely than a primary-feeder fault. In some cases the resulting service interruption may be serious enough, however, to justify a more elaborate form of secondary substation, such as those shown in Figs. 13 (b) and (c). A fault on one of the radial secondary feeders from a secondary substation is cleared by the tripping of the air circuit breaker associated with the faulty feeder. This interrupts service to those loads connected to that feeder until the fault can be located and repaired.

The investment in sectionalizing breakers and relaying may make a loop system employing primary feeders similar to that of Fig. 22 (a) more expensive than the necessary quality of service justifies. If an outage to a secondary substation can be tolerated when a primary-feeder fault occurs a loop-feeder arrangement can be used as shown in Fig. 22 (b). Here only one sectionalizing breaker is used with each secondary substation thus reducing the number of these breakers to half of the number used in Fig. 22 (a). The sectionalizing breakers are relayed as discussed in connection with Fig. 22 (a). When a primary feeder fault occurs the two breakers at the ends of the faulty section open as in the previous arrangement. In this case, however, the secondary substation associated with the faulty section is deenergized because its transformer is tied directly to the feeder section through a disconnecting switch, a primary transformer breaker, or a fuse. Service to the deenergized substation cannot be restored until the fault has been located and repairs have been made.

There is one exception to the above. A fault in the left feeder section just beyond the distribution substation bus does not interrupt service to any of the secondary substations. The sectionalizing breaker associated with this line section and the adjacent secondary substation can be omitted, and then this substation is deenergized at the time of a fault in this section. Whether omitting this breaker appreciably reduces the continuity of service to this first substation connected to the loop, when going from left to right, depends on whether its associated loop section becomes much longer than the other loop sections. Except for primary-feeder faults this system functions similar to the loop system previously described.

Sometimes a consumer connected to the loop requires more reliable service than the arrangement of Fig. 22 (b) provides. Service to this consumer can be improved in several ways. Two sectionalizing breakers can be used, one on each side of the point where the secondary substation that serves him is connected to the loop, as shown in Fig. 22 (a). Another way is to divide the transformer capacity of the secondary substation serving this consumer into two units, and connect one of these units or transformers to the loop feeder on each side of the single sectionalizing breaker. Each of these transformers should have sufficient capacity to supply the entire station load and is usually connected to the loop feeder through a circuit breaker or fuse. The two transformers are ordinarily bused on the secondary side through transformer-secondary breakers. When this arrangement is used a feeder fault in either of the two loop sections immediately adjacent to the sectionalizing breaker results in the deenergization of one of the two transformers at the sub-station. This is because the sectionalizing breaker at the station, the sectionalizing breaker at the far end of the faulty section, and the breaker in the secondary leads of the transformer connected to the faulty section are tripped. When this happens the secondary substation load is fed over the good loop section which is adjacent to the open sectionalizing breaker at the station, and its associated transformer.

A third way of improving service is to supply the consumer through a single-transformer substation arranged so that it can be connected to either side of its associated sectionalizing breaker by a double-throw switch or two interlocked disconnecting switches. Service will then be interrupted to the secondary substation when a fault occurs in the loop section to which the station is normally connected. The station loads can be quickly reenergized, however, without waiting for repairs, by connecting the substation to the good section of the loop on the other side of the open sectionalizing breaker.

The above discussion of the loop system has been on the basis of supplying relatively small bulk loads from distribution substations over loop primary feeders. In many cases, however, where the bulk loads are relatively large the loop is a subtransmission loop supplied directly from a bulk power source. In such systems the distribution substations and primary feeders are omitted and only one voltage transformation is employed in going from subtransmission to utilization voltage. This transformation is made at the secondary substations, which are usually considerably larger and somewhat more elaborate than those employed on 2400 to 4800 volt loop-primary feeders. The arrangement of the subtransmission loop and its control and protection is in general similar to that discussed in connection with the loop-primary feeders of Fig. 22.

Any form of loop system normally provides a two-way

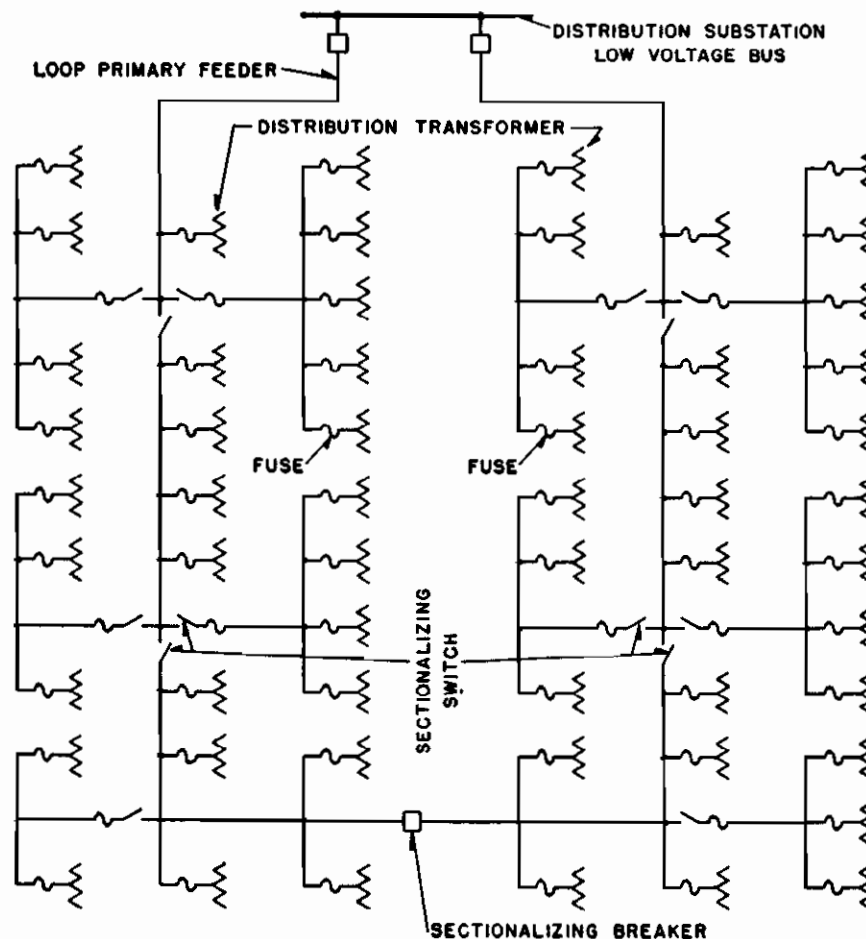

Fig. 23—Common arrangement of loop primary feeder for supplying distributed loads.

feed to the distribution transformers or secondary substations. In general, the service continuity and voltage regulation provided is better than when using a radial system. The amount by which the quality of service of the loop system exceeds that provided by the radial system depends upon the particular forms of the two systems being compared. Ordinarily the loop system will be more expensive than the radial system. Also it is usually less flexible than the radial system particularly in the forms used in supplying bulk loads discussed above. This is principally because two circuits must be run to each new secondary substation location in order to connect the station onto the loop. The addition of new substations on a loop feeder also often results in relaying complications.

While the loop system has been discussed from the standpoint of supplying bulk industrial and commercial loads it is also used to supply distributed loads such as residential loads. The chief reasons for supplying such loads from a loop system rather than a radial system are to improve voltage conditions, to equalize the load on and take advantage of the diversity between what would otherwise be two radial primary feeders, and to assist in the restoration of service to the unfaulted portions of a faulted feeder.

A common arrangement of a loop-primary feeder for supplying distributed loads is shown in Fig. 23. The similarity between this loop-feeder arrangement and the radial-primary feeders of Fig. 18, where emergency ties are provided between adjacent feeders, is apparent. Each end of the loop-primary feeder is connected to the low-voltage bus of its distribution substation through primary-feeder breakers. The main feeder is automatically sectionalized near its midpoint by a sectionalizing breaker controlled by overcurrent relays. Manual sectionalizing switches are provided at other points in the main feeder as shown in order to reduce the area that must remain without service, until repairs are made, when a fault occurs on the main feeder. Fuses are not used in the main-feeder loop. The sectionalizing breaker could be replaced with fuses at some sacrifice in the speed of restoring service, but not more than one set of fuses should be used in the loop because they will not operate selectively for feeder faults in various locations. More than one automatic sectionalizing breaker could be used in the main loop with directional-overcurrent or pilot-wire relaying, as was done in Fig. 22, to reduce the extent of the outage when a main feeder fault occurs. The improvement in the quality of service obtained, however, is not ordinarily sufficient to justify the additional breakers and the more complicated relaying. The subfeeders are provided with primary fuses or fused cutouts as in the case of the radial-primary feeders previously discussed. When a fault occurs on the main feeder loop the sectionalizing breaker opens quickly and splits the loop feeder into two radial feeders. The primary-feeder breaker associated with the faulty half of the loop feeder then opens and disconnects the fault from the system. This results in an interruption of service to about half the loads normally supplied over the loop-primary feeder. Service can be quickly restored to all deenergized loads except those connected to the faulty section of the feeder

by opening the sectionalizing switch or switches associated with the faulty section and then reclosing one of both of the tripped breakers depending upon the location of the fault. Faults on the subfeeders and laterals are cleared by their associated primary fuses. These fuse operations do not interrupt service to any of the feeder loads except those beyond the blown fuse on the sub-feeder and laterals. As in the case of the loop feeders or Fig. 22 this loop-primary feeder should be designed to permit its carrying all loads that can be connected to it when any section of the loop is out of service.

REFERENCES

1. *Overhead Systems Reference Book*, National Electric Light Association, New York, 1927.
2. *Underground Systems Reference Book*, National Electric Light Association, New York, 1931.
3. *Electrical Distribution Engineering* (a book), by Howard P. Seelye, McGraw-Hill Book Company, Inc., New York, 1930.
4. *Electric Distribution Fundamentals* (a book), by Frank Sanford, McGraw-Hill Book Company, Inc., New York, 1940.
5. Variable Elements in the Cost of Distribution of Electrical Energy, by Norman H. Gibson, *E.E.I. Bulletin*, June 1933.
6. Fundamentals of Design and Electric Energy Delivery Systems, by J. Allen Johnson and R. T. Henry, *A.I.E.E. Transactions*, Vol. 53, 1934, pp. 1704-1711.
7. The Effects of Service Standards on System Design, by N. E. Funk, *E.E.I. Bulletin*, July 1935.
8. Firm Ratings as a Guide to System Loading and Design, by S. M. Dean, *E.E.I. Bulletin*, June 1936.
9. Trouble Analysis and Power System Economics, by W. B. Elmer, *E.E.I. Bulletin*, October 1937.
10. Considerations Involved in Making System Investments for Improved Service Reliability, S. M. Dean, *E.E.I. Bulletin*, November 1938.
11. System Service and Economy, *Electrical World*, November 10, 1934.
12. Trends in Power Distribution, *Electrical World*, May 23, 1936.
13. Urban Distribution Symposium, *Electrical West*, May, 1939.
14. Progressive Distribution, by Merrill De Merit, *Electrical World*, April 27, 1935.
15. System Planning to Save Millions in Fixed Charges, *Electric Light and Power*, November 1933.
16. Pertinent Facts in Primary Distribution Economics, by D. K. Blake, *Electrical World*, April 22, 1933.
17. Save Money on Secondary Distribution, by D. K. Blake, *Electrical World*, September 23, 1933.
18. Can Distribution Cost Be Cut 40 Per Cent?, by Merrill De Merit, *Electric Light and Power*, April, 1935.
19. Distribution Service and Costs, by M. M. Koch, *Electrical World*, March 16, 1935.
20. Cutting Distribution Costs, by John S. Parsons, *Electric Journal*, March 1935.
21. Facts on Distribution Costs, by Howard P. Seelye, *Electrical World*, June 20, 1936.
22. Practical Distribution Economics, by H. S. St. John, *Electrical World*, September 7, 1940.
23. Secondary System Economy, by Howard P. Seelye, *Electrical World*, October 12, 1935.
24. Modernization of Power Distribution Systems, by Howard P. Seelye, *A.I.E.E. Transactions*, 1936, pp. 75-84.
25. Cost Reduction and Reliability Keynotes Two Decades of Distribution Progress, by A. C. Monteith, *Electrical South*, February 1941.

26. Distribution Planning, by C. E. Arvidson.
Part I—Calculating Overhead Primaries, *Electrical World*, October 7, 1939.
Part II—Residential Loads, Diversities, *Electrical World*, October 21, 1939.
Part III—Design of Radial Primaries, *Electrical World*, November 4, 1939.
Part IV—Fixing Regulator Settings, *Electrical World*, November 18, 1939.
Part V—Transformer—Secondary Design for Service, *Electrical World*, December 2, 1939.
Part VI—Checking Transformer and Secondary Conditions, *Electrical World*, December 16, 1939.
27. Light, Portable Substation Affords Continuous Service, by M. J. Wohlgenuth and W. W. Richardson, *Electrical World*, November 4, 1939.
28. Immediate Automatic Reclosing of Circuit Breakers, by W. M. Emmons, *Electric Journal*, March 1935.
29. Economic Design of Overhead Primaries, by Paul H. Jeynes, *E.E.I. Bulletin*, May, 1938.
30. The Gathering and Evaluation of Data for Improving 4-Kv Distribution System Operation, by Harold E. Deardorff, *E.E.I. Bulletin*, July, 1938.
31. A Review of Overhead Secondary Distribution, by W. P. Holben, *A.I.E.E. Transactions*, 1937, pp. 114-122 and 189.
32. Banking Transformers Improves Service, by M. T. Crawford, *Electrical World*, November 23, 1935.
33. Light Flicker Reduced at Low Cost, by B. E. Ellsworth, *Electrical World*, November 23, 1935.
34. Secondary Voltage Dips, by Paul H. Jeynes, *Electric Journal*, June, 1936.
35. Banking Secondaries, by P. E. Benner, *Electric Light and Power*, April 1939.
36. Trends in Distribution Overcurrent Protection, by G. F. Lincks and P. E. Benner, *A.I.E.E. Transactions*, 1937, pp. 138-52.
37. Systematic Voltage Survey-Procedure and Application to Distribution Design, by R. W. Burrell and W. E. Appleton, *A.I.E.E. Transactions*, 1938, Vol. 57.
38. Voltage Drops in Radial Overhead Distribution Circuits, by W. R. Bullard, *E.E.I. Bulletin*, November, 1940.
39. Voltage Drop in Distribution, by E. M. Adkins, *Electrical World*, September 12, 1936.
40. Is Good Voltage Regulation Necessary and Practical?, by L. A. Buese and Frank A. Ayres, *Electrical West*, December, 1934.
41. A Graphical Method of Calculating Voltage Drop, by V. W. Palen, *Electric Light and Power*, January, 1938.
42. Primary Limits; Application of Feeder Voltage Regulators, by R. O. Loomis, *Electrical World*, November 2, 1940.
43. Regulation Beyond the Distribution Substation, by P. E. Benner, *A.I.E.E. Transactions*, 1935, pp. 832-37.
44. Automatic Boosters on Distribution Circuits, by Leonard M. Olmsted, *A.I.E.E. Transactions*, 1936, pp. 1083-96.
45. Applying Shunt Capacitors to Distribution Systems, by Sherwin Wright, *Electric Journal*, May 1937.
46. Capacitors Increase Distribution Capacity, by Sam H. Pollock, *Electrical World*, September 24, 1938.
47. Basis for a Program of Capacitor Additions on a Growing Distribution System, by V. G. Rettig, *E.E.I. Bulletin*, August, 1940.
48. Capacitors—Design, Application, Performance, by M. C. Miller, *Electric Light and Power*, October, 1938.
49. Current Control Broadens Capacitor Application, by A. D. Caskey, *Electric Light and Power*, February, 1940.
50. Application Data on Series Capacitors, by V. W. Palen, *Electric Light and Power*, March, 1940.
51. Series Capacitors Perform as Voltage Regulators, by V. W. Palen, *Electric Light and Power*, April, 1940.
52. Reclosing Breakers or Reclosing Fuses—Which?, by H. A. P. Langstaff, *Electrical World*, March 22, 1941.
53. Recent Developments in Cable Fault Locating, by James A. Vahey, *E.E.I. Bulletin*, March, 1939.
54. Economic Benefits of Scientific Line Clearing, by T. H. Haines and E. F. Robinson, *Electrical World*, January 14, 1933.
55. Tree Clearance for Overhead Electric Lines—Preliminary Suggestions, by G. D. Blair, *E.E.I. Bulletin*, August 1941.
56. Realignment Transformers with Distribution, by W. A. Sumner and J. B. Hodtum, *Electrical World*, June 22, 1935.
57. Choosing Transformer Sizes for Distribution Circuits, by R. Rader, *Electrical World*, January 16, 1937.
58. Maximum Allowable Loading on Distribution Transformers, by Howard P. Seelye and N. A. Pope, *E.E.I. Bulletin*, 1939.
59. Loading Limits for Distribution Transformers, Erik N. Nelson and J. Edwin Davies, *Electrical World*, October 19, 1940.
60. Distribution Transformer Load Testing Methods Used by the Detroit Edison Company, by W. E. Groves, *E.E.I. Bulletin*, February, 1939.
61. Field Testing of Distribution Transformers, by J. A. Tenbrook and L. R. Gaty, *E.E.I. Bulletin*, February, 1939.

CHAPTER 21

PRIMARY AND SECONDARY NETWORK DISTRIBUTION SYSTEMS

Original Authors:

John S. Parsons and H. G. Barnett

Revised by:

John S. Parsons and H. G. Barnett

I. DEVELOPMENT OF THE A-C NETWORK SYSTEMS

EARLY in the history of electric power distribution systems the d-c network system became the best method of serving loads in heavy load density areas of cities where a high degree of reliability was required. In the d-c network system power was carried at utilization voltage from several substations to points in the load area where the power was introduced into an interconnected grid of mains in underground ducts. Individual loads were supplied by services tapped off the mains. The several paths of supply to the grid and the fact that there were normally two or more paths in the grid to any service prevented service interruptions except for complete failure of power supply. As the load density and total load increased in d-c network areas the large amount of copper required, the cost of substation sites, and large, rotating conversion equipment made the cost of the d-c network practically prohibitive. The noise of the conversion equipment made it difficult to find satisfactory locations for substations.

1. The Secondary Network

The characteristics of the network system, particularly reliability and the fact that the network took full advantage of diversity among loads, made that system preferable if it could be installed economically. The relative compactness and the quietness of transformers suggested the use of an a-c network system in which several high-voltage feeders would be carried into the load area to supply transformers feeding into an interconnected grid of low-voltage conductors. By 1920 there was considerable thought being given to such a system. Some experimental installations using fuses for protecting a low-voltage a-c network proved to be unsatisfactory because of the operating limitations of fuses and possibly because of the lack of extremely careful design. This experience showed that directional control of power flow was required to prevent a fault in a transformer or primary feeder from interrupting service from the system.

In 1922 the first automatic low-voltage a-c network¹⁸ was installed using equipment which was subsequently improved by Westinghouse developments^{19,20}. With low-voltage a-c network transformers and network protectors perfected, the a-c network system equalled the d-c network system in reliability¹⁸. This high degree of reliability plus good voltage regulation, the convenience and comparatively low cost of alternating-current equipment, and the flexibility of the network system for load growth made

the a-c low-voltage network the recognized ideal distribution system for highest quality of service^{28,29}. In heavy-load areas the network usually was cheaper than any other system that attempted to give a high degree of reliability. In 1926 seven cities used the network and by 1949 the number had grown to 196.

2. The Primary Network

The attractive characteristics of the automatic low-voltage a-c network suggested the application of the network principle to the primary-feeders of a distribution system. As early as 1926 consideration was given to a primary network in which the distribution-system primary feeders would form interconnecting ties between distribution substations, network relaying would be used at the distribution-substation transformer breaker, and selective operation of feeder breakers would provide correct isolation of primary-feeder faults.

The development of an overcurrent relay with satisfactory inverse-time characteristics and the choice of relatively small substations facilitated the first economic application of the primary network in the Pittsburgh area in 1931^{7,10,11,12}. For areas of medium load density the primary network frequently was the most economical system, particularly where overhead construction was used. After the first installation in 1931 there was a gradual increase in the number of primary network installations; in 1942 twelve utilities were operating primary networks and thirteen others had installed unit substations with primary-network relaying so that primary-network operation could be initiated simply by completing tie circuits between substations.

II. THE PRIMARY NETWORK SYSTEM

3. General Description

A typical arrangement of a primary network system is shown in Fig. 1^{6,9}. Basically a primary network is a system of interconnected primary feeders supplied by two or more subtransmission circuits through several distribution substations or network units located at the intersection points of the interconnected feeders. Usually there are radial primary-feeder taps from the tie circuits between the primary-network unit substations, and in many cases radial primary feeders originate at the substation buses. Distribution transformers are connected to the tie circuits, to the radial taps off the tie circuits, and to the radial primary feeders out of the substations just as in a radial system.

Two or more subtransmission circuits are taken into the primary-network area to supply the several primary-net-

power is carried as close as is reasonably possible to the loads at subtransmission voltage with consequent minimum loss and voltage drop in the primary feeders.

The primary-network unit consists of the transformer to reduce subtransmission voltage to primary-feeder voltage and the necessary switchgear to protect service from the network and to control the distribution feeders. The transformer breaker is provided with network and overcurrent relaying so that it not only opens on reversed currents to faults in the associated transformer or in the subtransmission circuit supplying that transformer but also serves as back up protection for the feeder breakers and isolates intersection faults. Furthermore, the network relaying functions to close the main breaker when the transformer voltage is such that power flows into the primary feeders when the breaker is closed.

There are two general forms of the primary network depending on the location and number of breakers in the tie circuits. The original form uses two breakers in each tie circuit, one at each end as shown in Fig. 1. The other form uses one breaker, normally near the middle of each tie circuit, as shown in Fig. 2¹⁵. In the two forms the network

transformer and the transformer breaker are fundamentally the same. In both forms the primary-feeder breakers are controlled by overcurrent and reclosing relays. In the arrangement shown in Fig. 1 a fault on a primary tie feeder is isolated by the breakers at the ends of the faulted circuit. In the other form of the system, Fig. 2, a similar fault is isolated by the transformer breaker at the end of the faulted section of the tie circuit and the breakers in all the tie feeders connected to the transformer whose breaker opens. The chief advantage of the original form of the primary network is that less load is interrupted by a tie feeder fault than in the later form using mid-tie breakers. In a case where four tie circuits are connected to each unit a tie-circuit fault in the original form interrupts only half as much load as does a similar fault in the other form. However, the system using mid-tie breakers uses only half as many tie breakers as does the original form.

4. Operation of Network with Two Breakers Per Tie

The operation of the primary network with two breakers in each tie circuit is described best by reference to Fig. 1. Under normal conditions all network units are in serv-

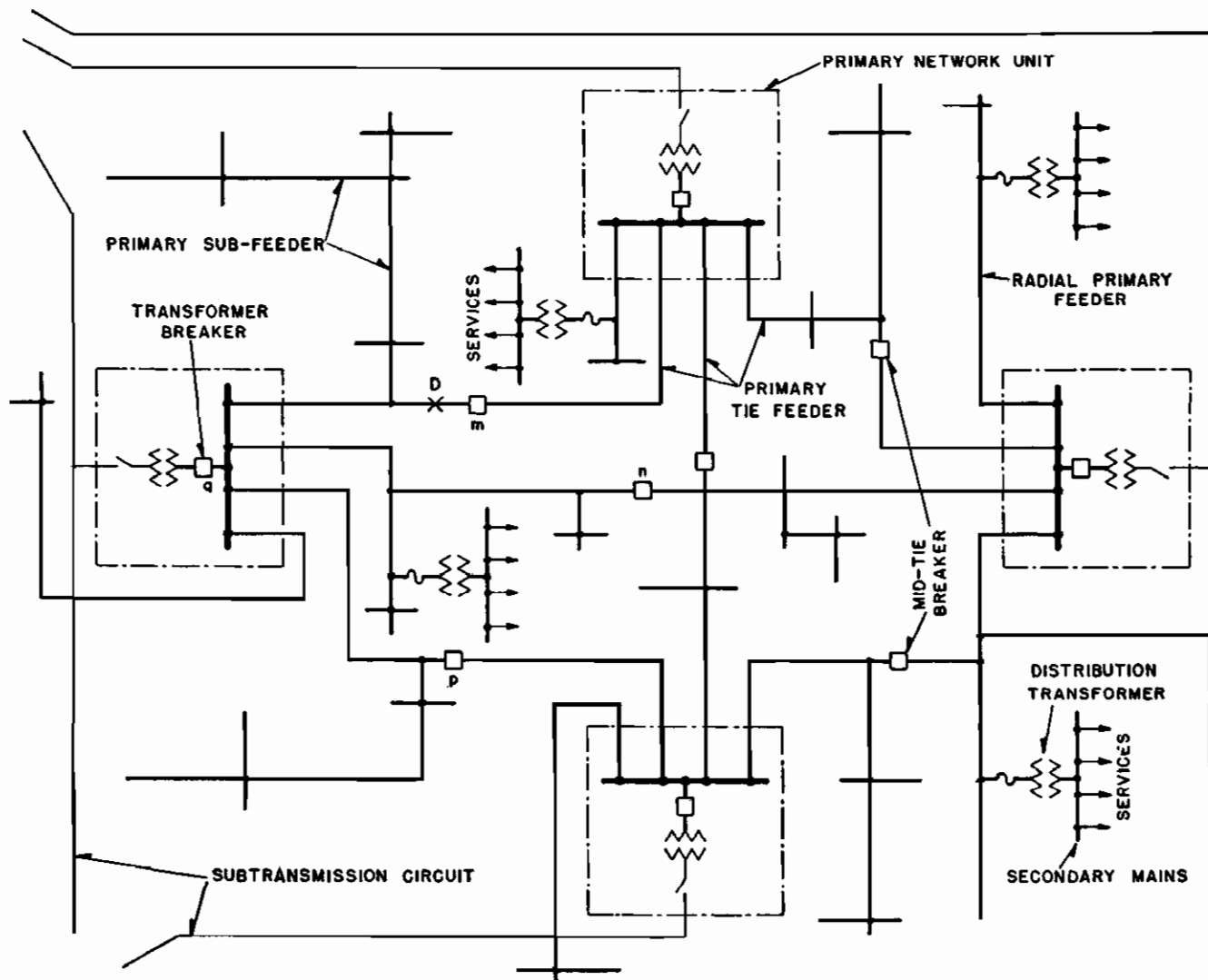

Fig. 2—Typical primary-network arrangement using one breaker at the middle of each tie feeder.

ice and the load is divided among the various units. Under fault conditions the faulted element of the system is isolated without interrupting service from the rest of the network.

Supply-Line Faults are isolated by the breaker at the supply end of the subtransmission circuit and the transformer breakers in the network units connected to the faulted circuit. For example, the subtransmission-line fault at *A*, Fig. 1, is isolated automatically by opening the circuit breaker at the supply end of the faulted circuit and transformer breaker *a*. In an extensive network system a subtransmission circuit may supply several network units and the transformer breakers in all these units open to isolate a fault on the supply circuit. The transformer breaker *a*, Fig. 1, opens on reversed current through the transformer from the network to the supply circuit. If a subsequent reclosure of the supply-circuit breaker reenergizes the subtransmission line, transformer breaker *a* recloses because of the overvoltage-reclosing function of the network relays, provided the voltage on the reenergized subtransmission line is correct with respect to the network voltage. A network-transformer fault is isolated in the same way as a subtransmission-line fault. The faulted transformer can be disconnected from the subtransmission circuit by means of the switch on the high-voltage side of the transformer, and the subtransmission line can be reenergized to supply other loads connected to it.

Tie-Feeder Faults—The operation of the network system on tie-circuit faults is illustrated by fault *B*, Fig. 1, which is isolated by breakers *b* and *c* opening on overcurrent. These breakers open before breakers in other tie circuits, because of the broad-range, inverse-time characteristics of the relays, even though the fault currents through other adjacent tie-circuit breakers exceed the minimum currents required to close the respective relay contacts. As long as there are at least two tie circuits or a tie circuit and a transformer circuit in addition to the faulted circuit connected to the same bus, selective operation of the breakers is assured because the breaker in the faulted circuit carries the sum of the currents through the other breakers.

As soon as fault *B*, Fig. 1, is isolated, automatic reclosing of breakers *b* and *c* is initiated so that each breaker recloses after its respective time delay. Assume that the time delay before reclosing is 15 seconds for breaker *b* and 30 seconds for breaker *c*. Then 15 seconds after breaker *b* opens it recloses. If the fault has cleared, service is restored to loads on the tie feeder but if the fault has not cleared, breaker *b* opens and locks out. Thirty seconds after breaker *c* opens (approximately 15 seconds after breaker *b* recloses), breaker *c* recloses and either reestablishes service from the tie circuit or locks out. If the fault clears before the first breaker recloses, the second breaker reclosing reestablishes normal operation of the network system. However, if the fault clears between the first and second reclosures, service to all loads is reestablished but the tie circuit is open at one end and it is not capable of transferring load from one unit to the other. Normal operation of the tie circuit is reestablished by manually reclosing the breaker which closed first and locked out.

Intersection-Bus Faults, for example at *C*, Fig. 1,

are isolated from the system by the overcurrent tripping of all tie-feeder breakers connected to the faulted bus, breakers *c*, *e*, *f*, and *g* for fault *C*. The overcurrent relays for breaker *g* not only trip and lock out that breaker but also trip and lock out all the feeder breakers connected to the same bus. This prevents the tie-feeder breakers reclosing and reenergizing a bus fault and causing unnecessary damage to the switchgear unit. The transformer breaker operates just as it does for a bus fault when a primary-feeder breaker fails to open and clear a feeder fault. The time setting for the transformer breaker is longer than that for the feeder-breaker relays so that the transformer breaker can provide back up protection for the feeder breakers and still give the feeder breakers ample time to operate correctly. For example, if breaker *d* should fail to open for a fault on its associated feeder the overcurrent relays at breaker *g* would trip and lock out breakers *c*, *d*, *e*, *f*, and *g*. Since the transformer has a long-time setting the breakers at either or both ends of the tie circuits connected to a faulted bus may open before the feeder breakers at the faulted bus are tripped and locked out by the transformer breaker overcurrent relays. In the example shown in Fig. 1, fault *C* might cause breakers *b*, *h*, and *k* to open before breakers *c*, *e*, and *f* are locked open; the result would be that service from any or all tie feeders *b-c*, *h-e*, and *k-f* would be interrupted momentarily. However, breakers *b*, *h*, and *k* would reclose and reestablish service to all the interrupted loads after a time delay of 15 or 30 seconds. Before these breakers reclose, the breakers at the faulted bus are locked out and the fault is isolated from the system.

5. Operation of Network with One Breaker Per Tie

Supply-Line Faults—The operation of the primary network in Fig. 2 is the same as that of the network in Fig. 1 for subtransmission and transformer faults.

Tie-Feeder Faults—The operation for a feeder fault is different. For example, a tie-feeder fault at *D*, Fig. 2, causes feeder breakers, *m*, *n*, and *p* and transformer breaker *q* to open on overcurrent and isolate the faulted circuit. The mid-tie breakers remain open but after a predetermined time delay transformer breaker *q* goes through a prearranged succession of reclosures until the breaker locks out on a permanent fault or until the fault clears and reclosing the breaker reestablishes voltage on the primary feeders in the faulted area. If reclosing the transformer breaker establishes normal voltage on the feeders and the voltage is sustained for the time delay for which the mid-tie breakers are set, tie breakers *m*, *n*, and *p* reclose and the network continues to operate normally. A fault on a radial primary feeder supplied from one of the network units in Fig. 2 can be treated the same as a tie-feeder fault, or some sectionalizing device such as a breaker or a fused cutout can be used to isolate a faulted radial feeder from the network so that a permanent fault on the radial circuit does not interrupt service from the tie feeders.

6. Comparative Characteristics

The primary network has several characteristics which, in comparison with other general types of distribution systems, give the primary network definite advantages in

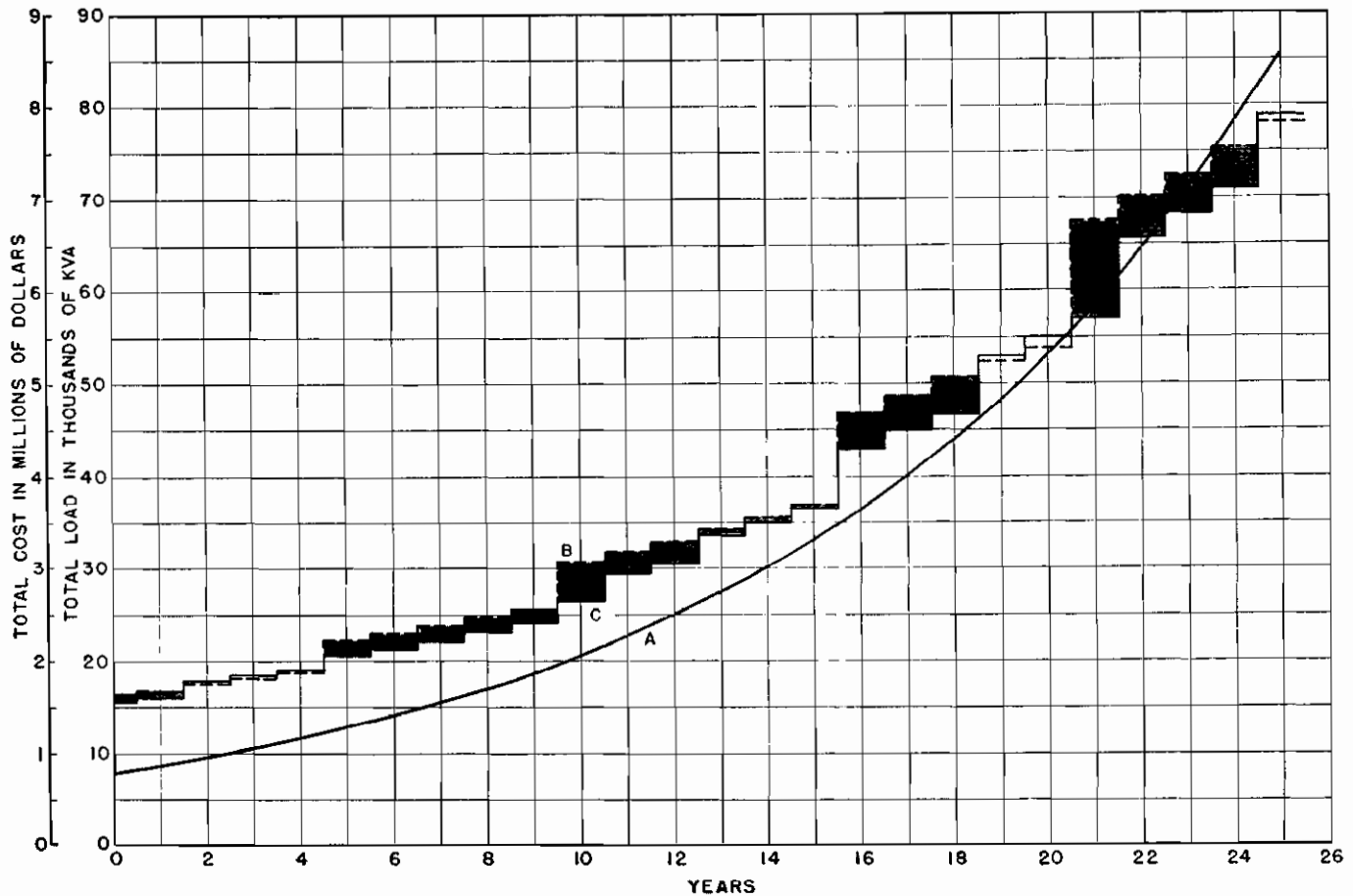

Fig. 3—Comparison of the costs of radial and primary-network systems over a period of 25 years in a uniformly loaded sixteen-square-mile area where the load growth is ten percent per year and all subtransmission circuits, primary feeders, and secondaries are overhead. A: Total load in the area. B: Total accumulated installed cost of a radial distribution system with 4-kv primary feeders supplied from large distribution substations. C: Total accumulated cost of a 4-kv primary network.

many cases. In general the primary network provides better service and can be adapted more flexibly to changing loads than other systems in common use except the low-voltage secondary network described later in this chapter.

Better Service results from better voltage regulation and fewer consumer outages. In many radial systems the primary feeders originate at relatively large substations and the average length of the feeders is greater than that in the primary network where small unit substations are distributed throughout the load area in accordance with the load distribution. This results in less voltage drop in the primary-network distribution feeders than occurs in radial feeders supplied by a large distribution substation. Essentially the same result is accomplished in a radial system by locating small unit substations at the load centers where primary-network units are installed. The tie circuits in the primary network, which generally are the main distribution feeders, are supplied from both ends. This usually will provide better voltage regulation in the primary feeders under normal conditions than is provided in the distributed radial system.

Consumer Outages are lower in the primary network system than in a radial system because the most services that will be interrupted by any fault in a primary network

are those on any one primary feeder. Even if many small unit substations are used in a distributed radial system several feeders are served by each unit. If one of these units is deenergized all the consumers served by the feeders out of that unit suffer an outage. Deenergizing a primary-network unit does not cause an outage for any consumer. To accomplish the same minimum consumer outage in the distributed radial system duplicate transformers and subtransmission supply circuits must be provided at each radial unit substation; this requires more transformer capacity, more miles of subtransmission lines, and usually more complicated relaying than does the primary network.

Losses in the primary network system generally are lower than those in radial systems for the same reasons that the inherent voltage regulation of the system is good. One of the two major reasons is that power is carried as near to the loads as practicable by high-voltage low-current subtransmission circuits instead of by long lower-voltage higher-current primary feeders. The other reason is that the load along each tie feeder automatically divides between the two ends of the feeder so that minimum losses are maintained.

Flexibility—One important feature of the primary-network system is that it utilizes small unit substations each located at or near the center of the load it serves. This and

the interconnected system of primary feeders makes it possible to remove or add small increments of transformer capacity at various places in the network area without having to make extensive reconnections of the primary feeders or to reroute large sections of circuits. In other words the network system is flexible in that it can readily accommodate load growth or load shifting with minimum disturbance to the system.

The flexibility of the primary network is a decided advantage in the long-time over-all economy of a distribution system, particularly where the total load changes with time or where load shifts from one section to another. Load growth or shifts can be accommodated by the primary network with a minimum of rerouting and reconnecting primary feeders and with relatively small increments of substation capacity. For this reason the system investment can be kept more nearly proportional to the load served than in the case of other systems where substation capacity has to be changed in large increments or major rerouting and reconnecting must be done to avoid overloading or underloading radial substations. The effect of this on the system investment is shown in Fig. 3. The primary network is characterized by regular small increments of investment while the radial system occasionally requires large additions to the system.

Large Number of Substations—The primary network requires many relatively small substations in comparison with a radial system supplied by a large substation at the load center of a large load area. A large number of substation sites and structures must be provided for the primary network. However, each of these sites usually is cheaper than that for a large radial station. Smaller sites are required by the relatively small primary network units. Furthermore, in most cases several small substation sites can be found scattered throughout a load area more readily than can a single large one near the load center of the whole area because the load center usually is in the most highly developed section of the area. On the basis of real-estate requirements the primary network is comparable with the radial system using small unit substations distributed throughout the load area.

Large Amount of Subtransmission Required—The primary network requires more subtransmission line to supply the small substations distributed throughout the load area than a radial system using large substations. The amount of subtransmission circuit required depends on the amount of interlacing of the supply circuits in the network area. The minimum of subtransmission line is required by parallel subtransmission, that is when each supply circuit is taken straight through the network area and connected to all the substations along that line. More uniform load distribution when a subtransmission circuit is out of operation can be accomplished by interlacing the supply circuits so that each deenergized unit is surrounded as completely as possible by units in operation. This requires more subtransmission line than does the arrangement using supply lines going straight through the network area. However, the saving in spare transformer capacity to provide for emergency operation usually more than pays for the additional subtransmission circuit. See section 13.

If the primary network with well interlaced subtransmission circuits is compared with a radial system using small unit substations distributed throughout the load area each of which is supplied by only one subtransmission circuit the network requires more subtransmission line. The additional line is primarily due to the interlacing. Interlacing accomplishes no useful purpose in the radial system. However, if duplicate supply circuits to each radial unit substation are used to reduce the number of consumer outages the radial system may require more subtransmission circuit than a primary network.

Primary Feeders About Equal—The primary network uses about the same amount of primary feeder circuits as does a distributed radial system. The main trunk feeders usually are about the same in a given area for either system. But in the primary network additional short sections of primary circuit may be required to make the tie circuits continuous between substations. Also in the network the tie circuits must have the same size copper throughout their length while radial primary feeders sometimes are graded down to smaller size copper as the load decreases along the circuit. However, the primary-feeder circuit required by the network may be no greater than that required by the radial system if it is necessary in the radial system to extend feeders from one substation area into another area to equalize the loading on the radial substation units or if normally open ties are provided so that the load in one radial-substation area can be picked up by other substations when that unit is out of service. See Chapter 20, Fig. 18.

7. Economic Field

It is impossible to say that the primary network is economically applicable in any specific range of load density because many factors affect the relative overall costs of the various systems that may be considered adequate in specific cases. The voltage class, type of construction used for the subtransmission and primary-feeder circuits, the load density, the anticipated rate of load growth, the required quality of service, real-estate cost, type of substation required, and local labor and material costs affect the economic comparison of systems in any particular case. The choice of the type of distribution system to supply any load area should be based on the overall cost of distributing power in the area; the cost should include installed cost of equipment and circuits, cost of the losses, and the cost of accommodating load changes over a reasonable number of years.

While no conclusive generalizations can be made regarding the economic field of application of the primary network some specific comparisons¹³ show where the primary-network system is likely to be the economical one. The comparisons shown in Fig. 4 show the relative cost of five types of system for four types of circuit construction in a sixteen-square-mile area where the uniformly distributed load is assumed to grow at the rate of ten percent per year. The four sets of curves, Fig. 4 (a, b, c, and d), show that for medium load densities in the range from 500 to 5000 kva per square mile the primary-network is likely to be economical, particularly if the system is to be predominantly of overhead construction. If all the subtrans-

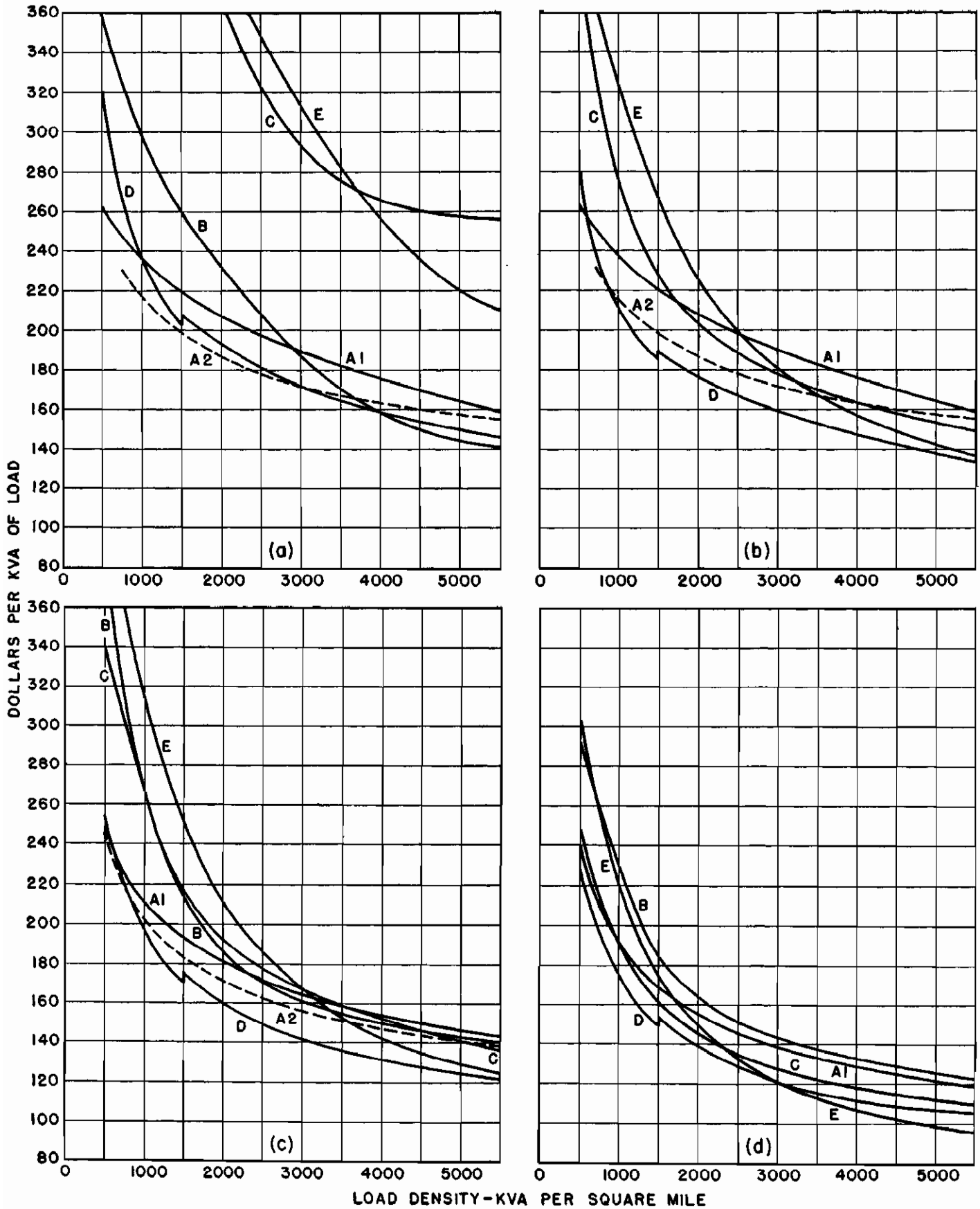

Fig. 4—Relative cost of several types of distribution systems for various load densities in a sixteen-square mile area where the uniformly distributed load grows ten percent per year. (a) Subtransmission circuits underground; all other circuits overhead open-wire. (b) Main subtransmission circuits underground; branch subtransmission aerial cable; 4 kv primary feeders and secondaries overhead open-wire. (c) Subtransmission circuits aerial cable; all other circuits overhead open-wire. A1: Radial system with 4-kv radial primary feeders with individual voltage regulators supplied by a 12 000-kva distribution substation. A2: Same as A1 except for 24 000-kva substation. B: Radial system with bus-regulated distribution substation and 4-kv primary feeders. C: Radial system with 13.2-kv subtransmission circuits supplying distribution transformers. D: Primary network with 4-kv primary feeders. Offset in curve at 1500 kva per square mile is due to increasing interrupting capacity of primary-feeder breakers. E: Overhead secondary network.

mission circuits are underground the relatively higher cost of that part of the system penalizes the primary network because more subtransmission circuit is required as compared to the radial systems.

The cost of the network is consistently low throughout the range of load density considered. Even in those narrow ranges of load density where the cost curve of some other type of system drops below the primary-network curve the primary network is only slightly more expensive than the other system, except for very low load densities when underground subtransmission is used. This is important in load areas where the load density is not uniform throughout the area. The flexibility of the primary-network system for accommodating load growth makes it better for nonuniform load density and irregular load growth than any radial system, particularly one using large centrally located substations. The use of large substations depends on accurate long-range load forecasting. Many large substations located on the basis of long-time load predictions are never fully loaded because the load does not grow as rapidly or as much as anticipated. Because the network system can be expanded in small increments long-time forecasting is not necessary and irregular load growth can be accommodated more economically by the network system. Therefore, in many cases where the primary-network system appears to be slightly more expensive than some other systems on the basis of uniform load density and regular load growth the additional cost of the network is more than compensated by the flexibility of the network system.

The curves of Fig. 4 are not conclusive evidence that the primary network is the most economical system for medium load densities. However, the curves do indicate that the primary network is likely to be economical in areas where the overall load density is between 500 and 5000 kva per square mile.

8. The Primary-Network Unit

Basically the primary-network unit consists of a transformer to step down the voltage from the subtransmission voltage to the primary-feeder voltage and circuit breakers to control the feeder circuits and protect the system from faults that may occur in the various circuits. These basic elements and their associated auxiliary equipment usually are assembled into a self-contained unit substation such as shown in Fig. 5. However when the primary network uses only one breaker near the middle of each tie circuit the network unit is usually an assembly of the transformer, the transformer breaker, and auxiliary equipment. The mid-tie feeder breakers are located along the tie circuits usually in the form of switchhouses.

The Transformer—A three-phase oil-immersed self-cooled transformer generally is used in a primary-network unit. Frequently air-blast equipment is provided so that occasional high overloads can be carried without exceeding safe operating temperatures in the transformer. The additional load capacity with air blast often is used as the spare capacity in the unit to take care of emergency loads when a subtransmission circuit is out of operation. The trend is toward air-blast cooling on all network units.

The primary-network transformer usually is provided

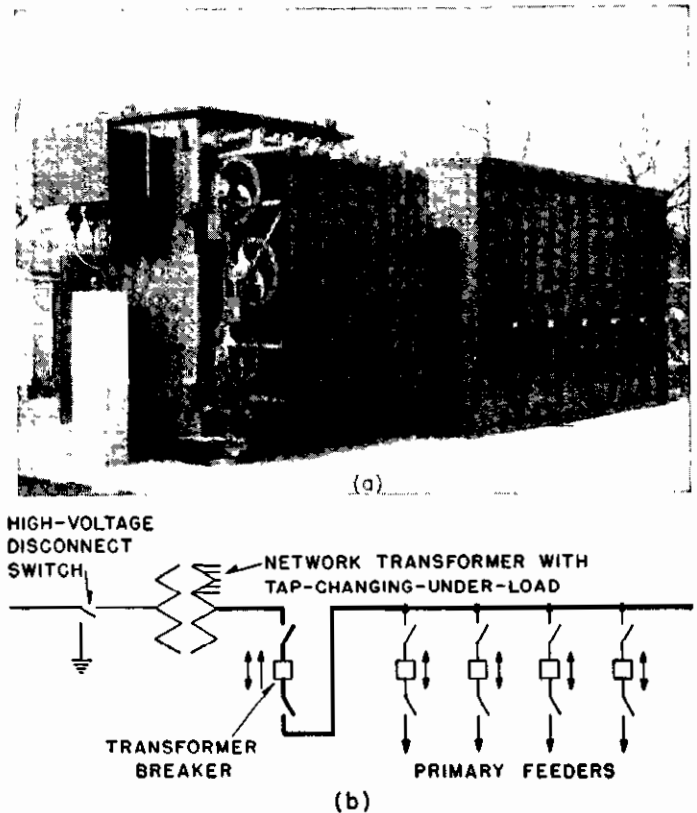

Fig. 5—Typical primary network unit. (a) Unit substation consisting of transformer with air-blast fans and tap-changing-under-load and throat-connected metal-enclosed switchgear. (b) Schematic diagram of a unit substation for operation in a primary network.

with a manually-operated primary disconnecting switch built into an oil-filled compartment on the transformer. The switch generally is capable of interrupting exciting current so that the transformer can be disconnected from the subtransmission supply circuit without deenergizing the supply circuit. Either a two-position or a three-position switch can be used depending on whether it is desirable to have a ground position in addition to closed and open positions. The ground position is for grounding the incoming supply circuit. The three-position switch generally is preferred.

A completely-self-protected transformer frequently is used in a primary-network unit. Such a transformer includes high-voltage fusible protective links, integral lightning protection, and a thermal relay for tripping an associated transformer breaker. When these elements are properly coordinated with the thermal characteristics and insulation of the transformer it is completely protected from damage from external causes. The completely-self-protected power transformer is described in detail in Chapter 16.

Voltage Regulation—Tap-changing-under-load equipment is generally built into the transformer part of the network unit so that the primary-feeder voltage of the network system can be maintained at the proper level. The operation of this equipment is described in Chapter 5. A range of plus or minus ten percent usually is used although in some cases a smaller range is adequate. The

choice of regulation range should be based on the maximum probable variation of subtransmission voltage at the network units and the voltage buck or boost to keep the primary-feeder voltage within the required limits. Since each primary-network unit normally serves a relatively small area the feeders out of any one substation are about the same length and have the same type of load. Under such conditions bus-voltage regulation is adequate. Furthermore, feeder-voltage regulation in a network system would be complicated and expensive.

The operation of voltage-regulating equipment in a primary network involves a problem that does not occur in the regulation of radial circuits. In the network system the voltage-regulating equipments in the various network units are operating essentially in parallel. When one regulator raises the voltage above the general level of the network system undesirable circulating currents flow through the network units and the tie feeders. If the control of the regulators is compensated* in the normal way so that the regulators hold higher voltage for peak load than for minimum load the circulating current may be increased as soon as it is established. The reason for this is that the circulating current appears to be a load current at the regulator that establishes the higher voltage and appears to be a reduction of load at regulators holding lower voltage. The result may be that once the unstable operation of the regulating devices is initiated the regulator holding the higher voltage tries to raise the voltage until the regulator reaches the upper limit of its range and the regulators holding low voltage try to lower the voltage until those regulators reach the lower limit of their range. The resulting circulating current may open several breakers and may completely interrupt the operation of the system.

The path of the circulating current is a closed loop extending from the power source through a subtransmission line to the transformers supplied by that line, thence through the primary network tie circuits, and back through network units to another subtransmission circuit by which it returns to the power source. The impedance of the loop is predominantly reactance. Therefore the circulating current lags the system voltage by a much larger angle than do load currents. This provides a simple means for preventing unstable operation of the regulating equipment in the primary network. Interconnecting the regulator controls in widely separated network units is not practicable. However, by the simple expedient of reversing the reactance elements¹¹ of the line-drop compensators in the control systems of the network-unit voltage regulators stable operation of the regulators can be enforced. This can be explained briefly by stating that a highly reactive circulat-

ing current flowing through the network unit toward the network causes the regulator to reduce the voltage at that point because of the effect of the reactive current acting through the reversed-reactance element of the line-drop compensator. Conversely a reactive current from the network through the network unit causes the regulator to raise the voltage. As a result the voltage difference between the units that causes the circulating current is corrected and stable operation of the regulators is maintained.

The resistance element of the compensator can be used to give a rising voltage characteristic at the primary network unit for increasing load currents. This generally requires somewhat higher settings for the resistance compensation than is necessary with normal reactance compensation. The most practical method of adjusting the compensator elements is to start with a fairly high reactance setting and a relatively low resistance setting and then by trial arrive at the best combination of settings. The reactance compensation can be reduced gradually until the minimum setting is found where stable operation is positive. This can be determined by manually moving the regulator away from the position corresponding to the desired system voltage. The regulator should return to the desired position automatically instead of continuing, in the direction of the manual displacement, to the end of its range. The resistance can then be increased to give the necessary compounding. Small readjustments in the reactance element may be necessary after the resistance element is adjusted. These adjustments should be made during light load because unstable operation is more likely at times of light load than at heavy load.

If it is sufficient to maintain constant voltage at the intersection buses in the primary network, the line-drop compensator does not function. In other words it is adjusted for zero resistance and reactance compensation. In such a case the regulators operate stably regardless of the connection of the reactance element. In fact if the voltage at some point on every tie circuit decreases as load increases on the adjacent network units the regulators operate stably with the reactance element not reversed.

The most economical rating of transformer usually will be between 1000 and 3000 kva depending on circuit construction, load density, location of units (outdoors or underground), and existing primary conductors. In order to use large units it is necessary to have correspondingly large primary-feeder circuits or to have a large number of feeders out of each substation. The latter means that the circuits are relatively long and that some of these circuits may have to be carried some distance from the station before any load is served. The additional cost of primary feeders may more than offset the savings in the cost of network unit and subtransmission circuit. The long-term total annual cost of large units is likely to be higher than that of smaller units because large units make it necessary to add capacity to the system in large increments. This is particularly important where the load is not uniformly distributed in the load area or where load growth is irregular. Both these conditions are more prevalent than uniform load density and a regular rate of growth. Past experience indicates that a 1500 or 2000 kva

*This compensation is accomplished by means of a line-drop compensator. The compensator consists of a variable resistance element and a variable reactance element. These elements are connected in series with the secondary winding of a current transformer in the circuit through the voltage regulator. The resulting voltage drops in the two elements are proportional to the line current of the regulated circuit. The two voltage drops are introduced into the voltage-measuring circuit of the regulator control in series with a voltage proportional to the system voltage at the regulator. The resistance element produces a voltage component 180 degrees from the regulator current, and the reactance element, as normally connected, produces a voltage lagging the current by 90 degrees. These elements are variable and can be adjusted so that the regulator holds not a constant voltage at the regulator but a voltage high enough to compensate for the resistance and reactance drops in a radial circuit and thus to maintain constant voltage at some predetermined point along the line. This explanation of the line drop compensator is rigidly correct only for a feeder regulator in a single line with load only at the end of the line. However, the line-drop compensator is used generally in all feeder arrangements to compound the voltage regulation so that a higher voltage is maintained at high-load than at light-load periods.

unit (1875 or 2500 kva with air blast) is usually most economical. Large units may appear economical in areas of heavy load density. However, in such areas the low-voltage secondary network should be carefully considered because it is probable that the secondary network is less expensive and it provides better service than the primary network.

Switchgear and Relaying—The two general arrangements of switchgear in a primary network are shown by Figs. 1 and 2. In the type shown in Fig. 1 there are two breakers in each tie feeder, one at each end. The arrangement in Fig. 2 uses one breaker in each tie feeder and this breaker is usually located near the middle of the tie; however, it may be located at any point in the feeder. From the standpoint of interrupting duty and of load affected by a feeder fault the midpoint location is best.

The one-breaker primary network costs less because it uses fewer breakers of lower interrupting capacity. Reclosures to reestablish service on faulted feeders do not disturb loads on the remainder of the network. In the two-breaker primary network feeder, faults drop less load and there are fewer locations where equipment must be maintained.

The switchgear for the two-breaker primary network is shown schematically in Fig. 5(b). The transformer breaker is provided with reversed-power and overvoltage-reclosing (network) relaying. The network relay disconnects the transformer from the network in the case of a transformer or subtransmission supply line fault and reconnects the transformer to the network when such a fault has been repaired and the relationship between the transformer and the network voltages is correct. The transformer breaker is also equipped with very-inverse-time overcurrent relays to isolate the transformer from bus faults and to provide back-up protection for the feeder breakers. This overcurrent relaying on the transformer breakers also trips and locks out the tie-circuit breakers connected to the same bus.

The network relay is inherently sensitive enough on reverse current to trip the transformer breaker on transformer exciting current when the transformer is energized from the low-voltage side. This makes it possible for the network relay to isolate single-line-to-ground faults on subtransmission circuits supplying the network, when using network transformers with their primaries connected in delta. It also facilitates testing and maintaining the supply circuit because it is not necessary to go to the primary-network units in order to deenergize the associated subtransmission line. This is particularly convenient when no radial loads are supplied by the same circuit that supplies network units because then the subtransmission circuit can be opened without interrupting any load. The use of sensitive-reversed-current tripping is complicated by the possibility of momentary reversals of power flow through the network transformers when radial loads are supplied by the same circuits that feed the network units. This is particularly true if the radial load is characterized by large abrupt fluctuations, as, for example, when large industrial motors or furnaces are started. To prevent such momentary reversals of power from opening the network-transformer breakers a desensitizing relay⁸⁸ can be used to

delay the tripping of the breaker on reverse currents up to about 150 percent of normal full load on the associated transformer. Thus momentary reversals of power that disappear before the time-delay interval is completed do not open the transformer breaker, but if the reversal persists the breaker opens at the end of the time delay. A delay of one to five minutes usually is long enough to take care of momentary reversals. With this arrangement reversed fault currents, which generally exceed two or three times normal rated current of the transformer, trip the breaker and isolate the faulted element without intentional time delay.

The feeder breakers are controlled by overcurrent relays and time-delay reclosing relays. The overcurrent relays should have broad-range, very-inverse-time characteristics to insure selective operation of the breakers in the various tie circuits so that a primary-feeder fault causes only the faulted circuit to be isolated. Current discrimination alone is inadequate for selective operation of tie-circuit breakers. If current-discriminating relays in all the tie feeders are set low enough to trip their respective breakers correctly on the minimum faults, the breakers in several tie feeders probably trip incorrectly on severe faults. The minimum fault current in a faulted tie feeder generally is lower than the maximum current in that feeder for a fault in an adjacent feeder. Definite-time settings for the overcurrent relays can be used to obtain satisfactory operation of the tie breakers if the settings are carefully selected for the various breakers. This method⁸ requires carefully planning the relay settings and depends, for correct operation, on accurate settings and the proper geographical sequence of the time delays in the tie feeders of the network. The broad-range, very-inverse-time relay scheme is the most practical method of providing selective operation of the feeder breakers because it permits uniformly low minimum current settings throughout the network and generally allows all the tie-feeder relays to be given the same settings.

The feeder-breaker overcurrent relays are set faster than the transformer-breaker relays so that any feeder fault is cleared by the feeder breakers before the transformer breaker can trip unless the feeder breaker that should isolate the faulted feeder fails to operate. If the feeder breaker fails to open, the transformer breaker operates and, in conjunction with the other feeder breakers connected to the same bus, isolates the faulted circuit.

Reclosing of the primary-feeder breakers is used in the primary-network system, as in radial systems, to reestablished service from a faulted circuit if the fault clears when the feeder is deenergized. Most temporary faults are cleared before the first or second reclosures. In the primary network two reclosures for any tie feeder can be provided conveniently by one reclosure at each end of the circuit. To prevent both reclosures occurring simultaneously or near enough together that the fault is not deenergized between reclosures it is necessary to use different time delays before reclosure at opposite ends of the line. The shorter time delay is made long enough that both breakers have ample time to open. The longer time delay is made long enough that the two reclosures do not occur simultaneously as a result of a large difference in the

opening times of the two breakers in the faulted feeder. Time delays of 15 and 30 seconds are generally adequate for the two reclosures. Using only one reclosure for each breaker minimizes the operating duty on the breakers.

The transformer breaker in the primary network with one breaker per tie feeder, Fig. 2, is controlled by network relaying and overcurrent relaying in essentially the same way that the transformer breaker in Fig. 1 is controlled. However, in addition to network and overcurrent relaying the transformer breakers in Fig. 2 are provided with reclosing relays so that the transformer breaker recloses on primary-feeder faults. Two or three successive reclosures are made before lock out. In the form of the network shown in Fig. 2 the transformer breaker usually is included in the transformer structure to form a completely-self-protected single-circuit unit substation.

The mid-tie breakers in Fig. 2 differ physically and functionally from the tie breakers in Fig. 1. These breakers are usually located along the tie feeders remote from the substation in widely separated locations and cannot be assembled together to form a switchgear unit. However, the breakers can be located anywhere along the tie feeders. If they are located at the intersections, those at a particular intersection can be grouped together to form a switchgear assembly. Mid-tie breakers can be mounted on a pole, on a platform, or on the ground. The control for a pole-mounted breaker is in a separate pole-mounted housing. A breaker mounted on a platform or on the ground can be either an outdoor breaker or a breaker in a switchhouse. Outdoor breakers require a separate weatherproof cabinet for the control and operating mechanism while the switchhouse type of mounting provides a weatherproof structure for the control, operating mechanism, and the breaker.

Mid-tie breakers are controlled by very-inverse-time overcurrent relays and voltage reclosing relays. The mid-tie breaker opens on overcurrent in either direction through the breaker and recloses only after substantially normal voltage is maintained on both sides of the breaker for a predetermined length of time. Power for closing the breaker can be taken from the tie feeder on either side of the breaker or from an adjacent secondary main supplied by the tie feeder.

The interrupting duty on breakers in any primary-network system depends not only on the short-circuit current of the adjacent network transformer but also on the characteristics of the network system because currents can flow to any fault over two or more paths. Unless the average tie-feeder impedance is more than about three times the network-transformer impedance, the network transformer will supply less current to a fault at its terminals than will the remainder of the network. Therefore, tie-circuit construction, load density, and the extent of the network are important factors in the interrupting duty on circuit breakers in a primary network system. In the type of system shown in Fig. 1 the duty on all the breakers at any substation is about the same and usually the variation of interrupting duty from one substation to another is not enough to justify using different breaker ratings in different substations. The interrupting duty on the tie breakers in the form of the primary-network system shown

TABLE 1—RANGE OF INTERRUPTING CAPACITY USUALLY REQUIRED FOR BREAKERS IN PRIMARY NETWORKS

Breaker	Type of Primary Network	
	Two Breakers Per Tie Feeder	One Breaker at Middle of Each Tie
Transformer Tie-Feeder	100 000 to 250 000 kva 100 000 to 250 000 kva	100 000 to 250 000 kva 25 000 to 100 000 kva

in Fig. 2 depends largely on their location in the tie circuits. If these breakers are located electrically at the middle of the tie feeder the maximum duty on them may be as low as a third of the maximum duty on the transformer breakers because the impedance in the tie circuit limits the fault currents. Table 1 shows the ranges of interrupting ratings generally required for the various breakers in the two forms of the primary network.

9. Designing the Primary Network

The design of the primary network, like that of any distribution system, must be based on complete and accurate load and geographical data, such as, (1) location, size, and character of large loads; (2) the amount, location, distribution, and character of the small loads; (3) anticipated load growth in the area being studied; (4) location of bulk power substations; (5) location and capacity of existing distribution circuits, transformers, and substations; (6) available sites for substations and other distribution equipment; and (7) available routes for distribution circuits. Preliminary analysis should reduce the load data to quantity of load and load centers corresponding to relatively small areas such as mile or half-mile squares.

Network Unit Locations—On the basis of the loads and location of load centers in the small areas network units are located at the load centers of larger areas each comprising a load corresponding approximately to the proportionate share of the total load in the network area that each unit will normally carry. The proportionate share of load for each unit is determined by the total number of units that must be installed in the network area. There must be enough units in normal operation so that under emergency conditions when one subtransmission circuit and the network units connected to it are out of operation the maximum capacity of the remaining units will be adequate for the total load in the area. A rough cost comparison can be made on the basis of a preliminary location of units to indicate the sizes of units that are likely to be most economical. Detail design and final comparisons then need be carried through for only a few combinations.

The actual location of network-unit substations depends not only on the location of the corresponding load centers but also on the location of available sites, available rights-of-way for subtransmission and primary-feeder circuits, and the location of existing distribution facilities that can be utilized. The choice of substation locations usually takes into consideration the cost of real estate and the need for landscaping or special construction to match the substation with the surrounding buildings and area.

Tie Feeders—The carrying capacity of the tie cir-

cuits between network units is related to the capacity of a network as well as to the load supplied from the circuit. Generally there are from three to five tie feeders connected to each intersection bus and for practical purposes the average can be taken as four. The carrying capacity of the four tie circuits should be enough to carry the maximum load on the corresponding network unit. Also each tie circuit must be able to carry all of its load from one end. The reason for this is illustrated by considering that the transformer of network unit E, Fig. 1, is out of service; then feeders *c-b*, *e-h* and *f-k* are supplied only at the *b*, *h* and *k* ends respectively. Under normal operating conditions, when all units in a network are operating, about half the load on the tie circuits connected to a network unit represent the normal load on that unit. Therefore, the combined carrying capacity of the tie feeders connected to a network unit must be at least twice the normal load on that unit. Actually each tie feeder should have a carrying capacity equal to about half the rated capacity, instead of the normal load, of the network transformer. On the basis of an average of four tie feeders connected to each primary-network unit, this carrying capacity usually gives enough margin to take care of unequal division of load among the tie feeders. The same size of tie-feeder conductors and network units generally is used throughout the network because of interchangeability and simplification of design and construction.

The tie feeders between primary-network units should follow reasonably direct routes. This keeps the impedance of the tie circuit to a minimum. Low tie-circuit impedance facilitates uniform load distribution among the network units and keeps voltage drop in the tie circuit to a minimum. These factors are particularly important under emergency operating conditions when a subtransmission circuit and its associated network transformers are out of service and some of the tie circuits are being supplied from only one end. Short tie feeders minimize the probability of faults on these circuits. Each tie feeder should follow a separate route as far as possible so that tree limbs, derrick booms, or similar hazards do not involve more than one tie feeder. Usually the installation of a primary network involves the adaptation of existing primary feeders to the tie circuits of the network system and the routes of the existing main primary feeders are major factors in routing the tie lines.

Either overhead or underground construction can be used for the tie feeders. The choice of the type of construction depends almost entirely on the class of neighborhood through which the feeders run and on the economic balance between the cost of underground construction and freedom from lightning, sleet, and tree troubles. When an existing system is adapted to primary-network operation the type of construction already being used usually determines the construction of the primary-network tie feeders. In areas of medium load density, where the primary network is generally applicable, overhead open-wire construction predominates.

Radial subfeeders and primary laterals can be supplied from the tie feeders in the same way that they are served by radial primary feeders. However, instantaneous de-energizing of the main tie feeder to clear temporary sub-

feeder faults and subsequent time-delay tripping of the feeder breakers to permit subfeeder sectionalizing fuses to clear permanent subfeeder faults cannot be used in the network system. Instantaneous tripping or delayed tripping of the tie-feeder breakers does not permit selective operation of the tie-feeder breakers in the various tie circuits of the network. However, the subfeeders can be fused so that faults on these circuits do not take the main tie feeder out of service. It is important that these fuses be carefully coordinated with the tie-feeder breakers so that subfeeder faults are correctly isolated from the main tie feeder. A radial primary feeder can be served directly from the primary-network units through its own breaker which usually is controlled by the same type of relaying used for the network tie circuits. However, any form of relaying can be used for a radial feeder breaker in a primary-network unit, if it coordinates properly with the network tie-feeder breakers.

Subtransmission Supply Circuits—At least two subtransmission circuits are required to supply a primary network; a larger number of supply circuits reduces the spare capacity required in the network units to provide for an emergency condition when one supply circuit is out of operation. It generally can be assumed that out of any number of supply circuits, up to about five or six, only one will be out of service at any one time. Theoretically two supply circuits require 100-percent spare transformer capacity so that when one of the two subtransmission circuits is out of service the transformers associated with the operating feeder can carry the total load; actually the maximum load capacity of all the network units has to be somewhat more than twice the normal peak load because the transformer ratings cannot be exactly fitted to the actual loads and because under emergency conditions the load probably does not divide uniformly among the transformers remaining in service. The corresponding theoretical reserve capacity for three supply circuits is 50 percent; for four circuits $33\frac{1}{3}$ percent; and for five circuits 25 percent. Practically, very little reduction of necessary reserve capacity results from using more than five or six supply circuits. When a larger number of circuits is used, some of the transformers in the network area will be remote from transformers that are out of operation and will pick up relatively little of the load normally supplied by the transformers associated with a supply circuit that is out of service. In other words, the reserve capacity in a network supplied by more than five or six subtransmission lines cannot be effectively utilized and the necessary percent reserve capacity in the network becomes practically constant as the number of supply circuits increases beyond five or six.

For more than five or six circuits the probability of two circuits being out of operation simultaneously may be great enough that such an emergency must be considered. More reserve capacity may be required in a network supplied by a larger number of supply circuits than in one supplied by five or six circuits. The number of subtransmission circuits that can be expected to be operating at any time must have enough capacity to carry the total primary-network load.

Interlacing of the subtransmission circuits, to avoid

adjacent transformers being connected to the same supply circuit, should be used to keep the spare capacity in the network to a minimum. The additional length of supply circuit usually is more than out-weighted by the saving in network unit capacity. See section 13.

The construction used for the subtransmission circuits depends on available rights of way, subtransmission voltage, and the value of the protection from lightning, storm, and tree hazards afforded by underground construction. Prevailing subtransmission circuits usually establish the type of construction to be followed by primary-network supply circuits. Closely built up areas may require underground or aerial cable lines while open areas may permit using overhead open-wire construction.

One important advantage of the network system is that the subtransmission circuits can be straight radial circuits protected by simple overcurrent relaying systems because service to all the loads in the network area is independent of the continuity of operation of any subtransmission circuit. The complicated relaying and duplication of supply circuits required by the subtransmission grid (See Chapter 20) are not necessary for the operation of a primary network. However, it is important that the supply circuits originate at bulk power stations that are closely interconnected so that the voltages on the various subtransmission circuits are maintained practically equal and in phase. This is necessary to insure uniform load distribution among the supply circuits.

Automatic reclosing of the breaker at the supply end of an open-wire subtransmission circuit supplying primary-network units is not as important as it is for primary feeders or subtransmission lines in a simple radial system. In the primary-network system a fault on a subtransmission circuit does not interrupt any load. Furthermore, it is not necessary to restore the faulted circuit to operation to maintain service to any loads served from the network. Reenergizing a subtransmission line connected to a faulted network transformer almost invariably would reestablish the fault and cause unnecessary damage to the transformer. If considerable radial load in addition to network load is served by an overhead subtransmission circuit, automatic reclosing of the subtransmission-line breaker may be justified by the reduction of the duration of outages for the radial load when temporary subtransmission-line faults occur. Reclosing is not used on subtransmission cables because a fault in a high-voltage cable usually does not clear when the cable is deenergized. Reclosing on faulted cable circuits usually causes unnecessary damage to the cable.

10. Modification of the Primary Network

The foregoing discussion has been confined to the two basic forms of the primary network both of which operate on the same fundamental network principle. Modifications that have been used or suggested are variations of arrangement and generally do not affect the fundamental operation. The two most important modifications are the use of fuses in place of mid-tie breakers and the adaptation of the network system to existing substations and distribution facilities. Fuses can be used in place of the mid-tie breakers in the system shown in Fig. 2 because

the reclosing to reenergize the primary feeders after a temporary fault is done by the transformer breaker. In the system using two breakers per tie feeder, substituting fuses for these breakers is not practical because the fuses do not provide means for reestablishing service on the tie feeders in the case of temporary faults. Reclosing fuses might be used for this purpose if suitable, accurate, long time delays could be incorporated in the fuse to insure properly coordinated operation of the fuses at opposite ends of the line. If fuses are used in place of mid-tie breakers they must be coordinated carefully so that the fuses in the various tie circuits operate selectively. One important disadvantage of these fuses is that the tie feeders must be patrolled frequently so that fuses adjacent to a substation near which a tie-feeder fault has occurred do not remain open for long periods of time and result in dropping load around that substation when it is taken out of service at some later time because of a transformer or subtransmission-line fault or for maintenance or testing.

Primary networks are usually applied in areas where there is an existing distribution system. For this reason it is often desirable to adapt existing substations to network operation. When the existing substations are equal or nearly equal to the network units that are to be used, it is necessary only to provide existing stations with network relaying and properly coordinated over-current relaying and to make sure that existing breakers are of adequate interrupting capacity. In larger stations it may be necessary to divide the station into sections nearly equal in capacity to the new network units to be installed. In some cases it may be feasible to segregate a small section of the bus in a large substation for operation in the network system and supply this section of bus from the main station bus through a bus-sectionalizing breaker and current-limiting reactor so that the normal load and the available short-circuit kva on the small bus section are comparable to that of the network units. In this latter case the sectionalizing breaker is relayed in the same way as the transformer breaker in a network unit, and the feeder breakers on the small bus section are provided with the same type of control as other tie-feeder breakers in the network.

Other modifications may suggest themselves in particular cases. Any modification should be made only after it has been determined that tie-feeder sectionalizing devices and network-unit transformer breakers are properly coordinated and correct operation of the network is assured.

III. THE AUTOMATIC A-C SECONDARY NETWORK SYSTEM

All the secondary networks now operating in 196 cities, with one exception,^{33,65} work on the same basic principle. Loads throughout a load area are supplied by taps from an interconnected system of low-voltage circuits. The utilization voltage,²⁶ at which the secondary mains are operated, varies among installations from 115/119 to 125/216 volts. The most prevalent voltage is 120/208 volts which provides a standard lamp voltage from line-to-neutral and a three-phase line-to-line voltage that is generally satisfactory for 220-volt motors.¹⁷ Power is supplied to this system of low-voltage circuits through several transformers

which in turn are energized by two or more primary-feeder circuits. Automatic network protectors^{56,57} and the natural tendency of low-voltage faults to clear themselves^{31,22} are utilized to protect service from the secondary network from all faults in the system, except complete failure of the power supply.

11. The Underground Secondary Network

The basic electrical arrangement of the secondary network is shown in Fig. 6. The grid of secondary mains is the interconnected system of low-voltage circuits from which loads are served at utilization voltage. The network transformers introduce power into the secondary mains at the intersection of the mains through network protectors, which are automatic air circuit breakers controlled by network relaying. Two or more primary feeders are used so that even when a primary feeder is out of service all of the load can still be supplied over the remaining feeder or feeders. The feeders to the network can come either from a distribution substation, from a bulk power substation, or a generating station. In network systems the feeders frequently operate at subtransmission voltage and are, in fact, subtransmission circuits carried directly to the distribution or network transformers.

Secondary Mains—The load circuits or secondary mains from which consumer services are tapped generally follow the geographical pattern of the load area because the mains are located under the streets or alleys in the area so that the services to the consumers can be as short as possible. This arrangement facilitates access to the mains for repairs, maintenance, and service connections. In underground systems the secondary mains as well as other circuits are generally carried in duct systems and the service connections are made in manholes, vaults, or shallow junction boxes. At the intersections of the secondary mains the corresponding phase conductors of the intersecting mains are connected together so that, in most city areas where the low-voltage secondary network is applicable, the system of secondary mains takes the form of a grid. In an ideal case the grid forms a regular pattern such as that shown in Fig. 6.

In underground systems the secondary mains generally are made up of single-conductor cables because the many interconnections and service taps required in a secondary network can be made more easily and less expensively on single-conductor cables than on multi-conductor cables. In the early stages of the network system lead-covered cables were used almost exclusively. Within the last decade improved insulating materials have resulted in extensive use of non-metallic sheathed cables⁵⁹ because splices can be made more easily. Although three-conductor cables generally are not used it is common practice to twist all the conductors of a three-phase circuit together to keep to a minimum the reactance of the circuit and thus improve voltage regulation.

The size of the conductors* in the secondary main depends primarily on the required carrying capacity. However, the voltage drop from a transformer to any load along the mains under normal operating conditions (all transformers in operation) should not exceed about two

*See Chapter 6.

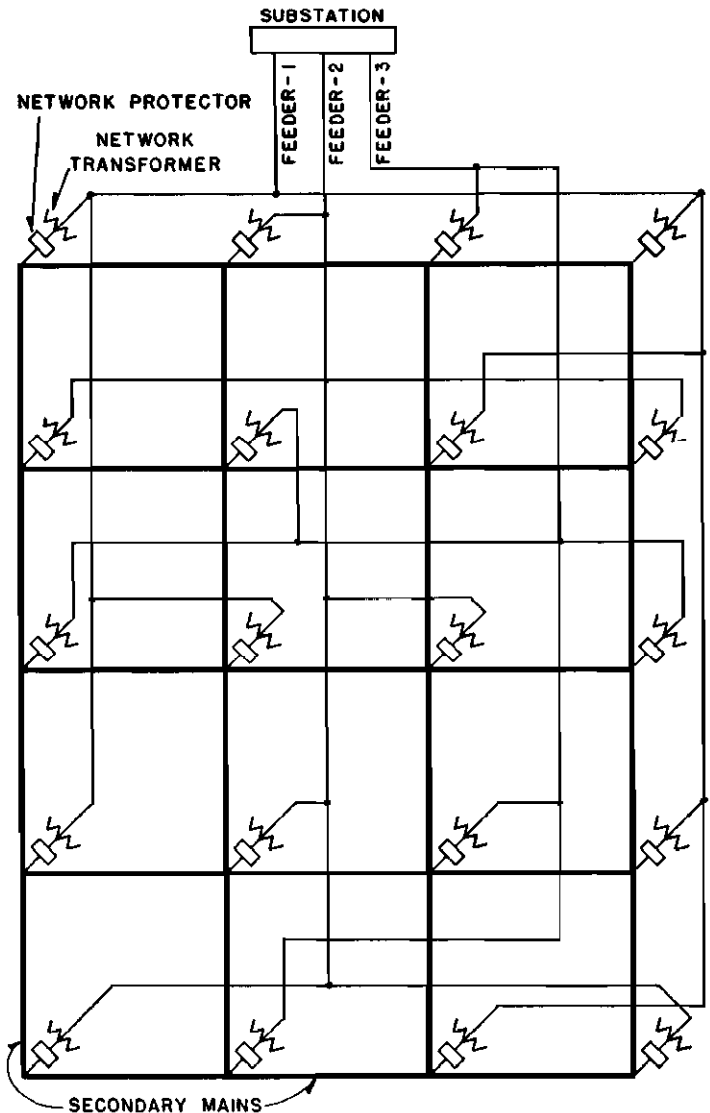

Fig. 6—Schematic diagram showing the basic arrangement of primary feeders, network transformers, and secondary mains in a low-voltage secondary network.

percent. The carrying capacity of a secondary-network main should be one-half to two-thirds of the rated capacity of the predominant size of network-transformer unit. This is true because a part of the maximum load on a transformer is usually supplied from the junction where the transformer is connected, and the remainder of the output of the transformer usually is divided unequally among the mains connected to the same junction as the transformer. Also, when the normal power supply from a network transformer at one end of a secondary main is out, all the load along the main and part of the load at the end where the transformer is out is supplied from the other end of the main.

The conductor sizes most frequently used in underground low-voltage networks are 4/0 and 250-, 350-, and 500-MCM. However, because of relatively high voltage drop, difficulty of handling, and the difficulty of burning clear faults on 500-MCM cable, two 4/0 or 250-MCM cables in parallel are frequently used in place of one 500-

MCM conductor. The improvement in voltage regulation⁴⁵ is shown by Fig. 7. Two 250-MCM conductors in parallel have the same copper cross-section and essentially the same resistance as one 500-MCM. The paralleled 250-MCM cables provide better regulation because the reactance of that circuit is about half that of the 500-MCM circuit. The smaller cables are easier to handle in the limited space in manholes and vaults. Where transformers larger than 500-kva are used in a network multiple-conductor circuits always should be used.

The operation of the secondary network depends on faults on the secondary mains being burned off and clearing without deenergizing the system. This is feasible on low-voltage circuits such as 120/208-volt secondary-network mains because arcs are not sustained at that voltage. For circuits operating at higher voltages such as 460 volts this method of clearing faults is not dependable. Tests⁴¹

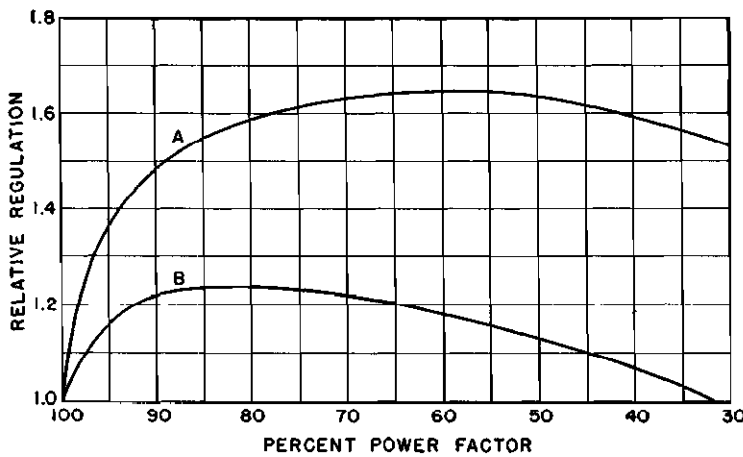

Fig. 7—Relative regulation per unit length of three-phase circuit for a balanced three-phase current at various power factors. A: For a circuit consisting of three 500-MCM single-conductor cables in a duct. B: For a circuit consisting of two parallel three-phase branches each made up of three 250-MCM single-conductor cables in a separate duct.

and calculations have shown that the minimum currents shown in Table 2 are required to burn clear the most severe type of fault. Such a fault is one where the current and thermal capacity of the fault is greater than those of the conductor itself making it necessary to fuse the conductor on each side of the fault. In an actual installation such a fault might occur when a power shovel digs into a duct line. The probability of such a fault is rather small. Most faults on network secondaries clear with much smaller currents than those shown in the tabulation. The values for underground circuits are for either lead-covered or non-lead-covered cables. A 500-MCM conductor is about the largest conductor that can be expected to burn clear consistently because larger conductors require high minimum fault currents, which are difficult to obtain in network mains except where the transformer capacity is highly concentrated, and also because of the large amount of metallic vapor generated when a large conductor fuses.

The ability of any network to clear secondary faults is improved by the use of paralleled-conductor circuits. Available short-circuit currents will burn off a small con-

TABLE 2—MINIMUM CURRENT IN AMPERES REQUIRED IN EACH CONDUCTOR ON BOTH SIDES OF A SOLID FAULT ON SINGLE-CONDUCTOR CABLES TO BURN OFF THE FAULT

Conductor Size	Overhead Circuit	Underground Circuit
1	1000	1600
1/0	1200	1800
2/0	1400	2100
3/0	1700	2500
4/0	2100	2900
250 MCM	2300	3200
350 MCM	3000	4000
500 MCM	4000	5000

ductor more quickly than a large conductor. Also with the parallel arrangement of the secondary-main conductors a fault opens only one of the branches of the main and leaves the other branch of the main in operation to help maintain the maximum possible fault current available at the fault point. Furthermore, the paralleled circuits of the main can be tied together at short intervals so that only a small section of the main is affected by a fault. Tying the parallel circuits together increases the fault current at the fault point in most cases.

The effects of paralleled mains and tie points are illustrated by Fig. 8. A fault near a junction is more difficult to clear than a similar fault at any other location on the main because the current to one side of the fault is limited by the impedance of the entire main. Such a fault in a well-designed network grid is quickly burned clear between the fault and the nearest junction point as shown in Fig. 8(a). Occasionally the fault current over a long secondary main is not enough to burn off a solid fault on a main consisting of a single-conductor per phase. The currents shown in Fig. 8 are calculated for the conditions shown. The current to a fault at the end of a 500-foot, 500-MCM secondary main, Fig. 8(a), will be 4250 amperes or only 85 percent of the 5000 amperes necessary to clear a solid fault

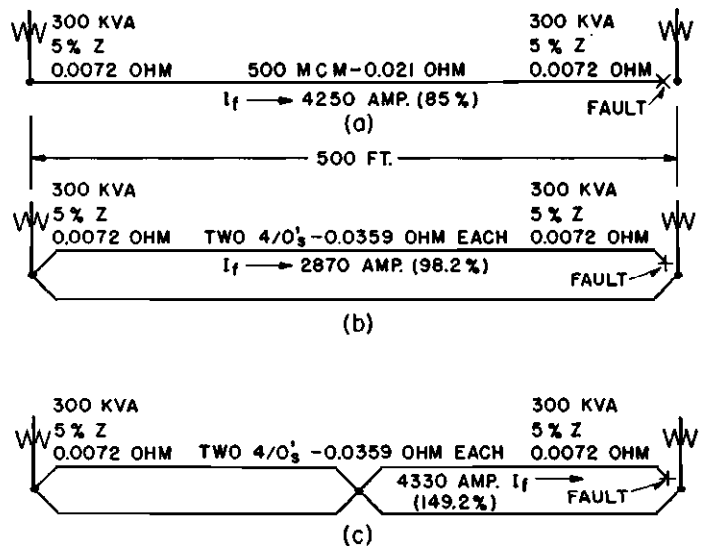

Fig. 8—Effect of paralleled conductors and tie points in paralleled conductors on the ability of a low-voltage network to clear secondary faults.

on that size conductor. If, as in (b), two paralleled 4/0 cables without tie points are substituted for the 500-MCM conductor the fault clearing ability is improved. There is still only 98.2 percent of the 2900 amperes required for the worst fault; however, the probability of the fault not clearing is very remote. But if, as in (c), the two paralleled 4/0 conductors are tied together at the midpoint of the main, the available fault current from the main to the fault is increased to 149.2 percent of the 2900 amperes required. This provides a wide margin, of safety. There are two reasons for this result. Both transformers can supply current to the fault even after it burns off on one side; and the effective impedance to the fault is less than that in either case (a) or (b). In the case of two 4/0 conductors per phase and 300-kva transformers, 100- to 150- foot intervals between tie points are short enough to burn clear a fault such as shown in Fig. 8(c), even on mains as long as 1350 feet. Mains of such length seldom occur in secondary networks. The effectiveness of this method depends on there being two branches of the main each in a separate duct to prevent a fault in one branch from communicating to the other. Usually these tie points are provided automatically by service taps along the mains; on a parallel-conductor main the branches should be tied together at service points because of the improved voltage regulation and decreased losses in the main.

Limiters—Frequently there are a few mains in a secondary-network grid where fault current is insufficient to insure clearing a solid fault. Also some severe faults result in a considerable amount of damaged cable before the fault is cleared. To minimize the amount of cable damage resulting from secondary faults and to avoid the infrequent cases where a secondary fault fails to clear in a reasonable time the limiter was developed and applied first in New York in 1936.^{58,64} The limiter also provides means for isolating secondary faults on secondary mains in fringe areas of a network where there is insufficient fault current available to fuse the secondary mains in the case of a solid fault. The limiter is a restricted copper section installed in the secondary main at each junction point; the fusing characteristics of the limiter are designed to clear a faulted section of main before the cable insulation is damaged by the heat generated by the fault current. The extent to which limiters are applied in a network depends on economic considerations as well as on the necessity for providing means of clearing faults. In some networks, limiters are installed in all secondary mains on the basis that the saving in damaged secondary cable justifies the application. It is cheaper to apply limiters on non-lead-covered cables than on lead-covered ones, especially if the lead sheath must be continued over the limiters by means of wiped-solder joints. Local costs and local secondary-fault experience must be considered in each case.

Network Units—A secondary-network unit consists of the network transformer and its associated primary disconnect switch and network protector. The network transformer is the distribution transformer in the network system. It combines the functions of both the distribution-substation transformer and the distribution transformer when subtransmission supply circuits are connected directly to the network transformers. The primary discon-

necting switch provides means for disconnecting a transformer from the primary feeder and it may also incorporate means for short circuiting and grounding the primary feeder for the safety of workmen when the feeder is being repaired or extended. The network protector⁶⁶ is an electrically-operated air circuit breaker controlled by network relays⁶⁷ so that it automatically disconnects the transformer from the secondary grid when power flows from the grid to the transformer and reconnects the transformer to the grid when the transformer can supply power to the grid. An installation of three network units in a vault is shown in Fig. 9.

Transformer—Three-phase transformers generally are used because the space required and weight of the transformer is less for three-phase units than for an equivalent bank of single-phase units and the cost is less for the three-phase unit. Single-phase transformers offer no advantage from the standpoint of service continuity because the interconnected secondary grid maintains the service at a transformer point even though that transformer is out of operation. However, when existing single-phase transformers have impedances and voltage such that they can be paralleled with network units, they can be used in a network system. This often occurs when an existing distribution system is converted to a low-voltage secondary-network system. Single-phase transformers sometimes are necessary because of space and weight limitations of elevators, hallways, doorways, manholes, and other means by which the transformers must be moved into position in vaults. This is particularly true for building vaults.

Oil predominates as the cooling and insulating medium for network transformers primarily because of its relatively low cost and because other suitable mediums were not

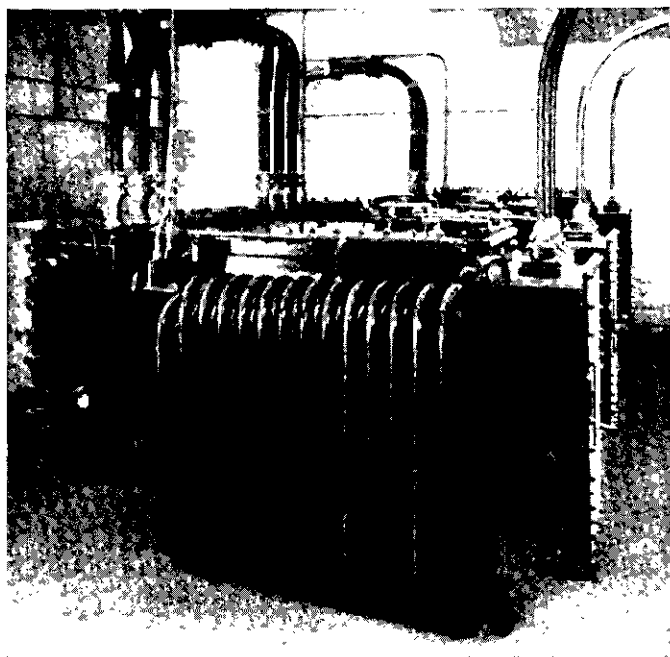

Fig. 9—Three submersible secondary-network units installed in a vault. Each unit consists of a 500-kva transformer with a 1600-ampere network protector on the left end and a primary switch and terminal chamber on the right end.

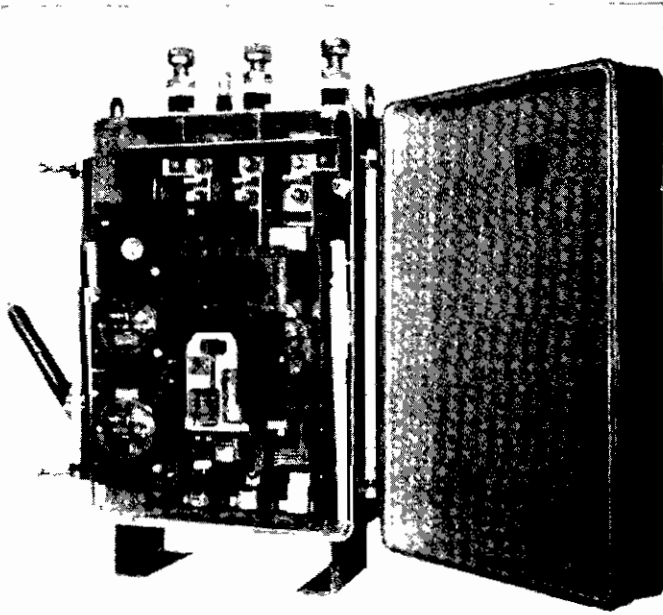

Fig. 10—A network protector in a subway housing. This is the type of protector that is mounted on the left end of the transformers in Fig. 9.

available in early stages of the development of the network system. The chief disadvantages of oil-filled transformers are the explosion and fire hazards. A non-inflammable liquid, such as Inerteen, eliminates the fire hazard and it is used in many cases where a fire would be difficult to control or would be likely to cause extensive damage. Both oil-insulated and non-inflammable-liquid-insulated transformers can be used where a submersible unit is required. Air-insulated transformers that use no liquid and eliminate both the fire and explosion hazards are particularly suitable for installations in buildings.

In addition to providing for a primary switch and means for mounting a low-voltage protector, a network transformer is carefully constructed to reduce the probability of internal faults. Submersible-transformer tanks are constructed to resist corrosion resulting from submersion. Resistance to corrosion is obtained by heavier tank bottoms and cooling tubes, alloy hardware, and special paint. The size of a network transformer is made as small as possible, consistent with proper electrical construction, to save transformer-vault space.

The High-Voltage Switch, with which a network transformer is generally provided, may be a two-position grounding switch, a two-position disconnecting switch, or a three-position disconnecting and grounding switch. The two-position grounding switch does not disconnect the transformer from its primary feeder; it short circuits and grounds the primary-feeder circuit at the transformer primary terminals. From the standpoint of safety this type of switch is adequate but it has the disadvantage that dielectric tests on the primary-feeder cables must be made with the primary windings of the network transformers connected to the cable circuits. If these windings are delta-

connected and are properly insulated a high-voltage d-c test potential can be used on the feeder cables. Star-connected primary windings make it impractical to use this type of switch because it is then practically impossible to test the feeder cables without disconnecting the transformer from the feeder cables. The two-position disconnecting switch facilitates testing the feeder cables but has the disadvantage that the feeder cable must be grounded separately to provide safe working conditions for repairing the cable. The three-position disconnecting and grounding switch provides both the safety of grounding the feeder cable and the convenience of disconnecting the transformer from the cable to facilitate testing the feeder cable. The three positions of this switch are "Transformer," "Open," and "Ground." In the "Transformer" position the feeder is connected to the transformer. In the "Open" position the transformer is disconnected from the feeder circuit. In the "Ground" position the primary feeder is disconnected from the transformer and grounded.

The primary switch is a manually operated device and generally is not capable of opening transformer exciting current. For that reason the switch usually is interlocked so that it cannot be operated unless the transformer is deenergized. Therefore, the feeder circuit must be deenergized at its supply end to deenergize the transformers before the disconnect switches can be opened. The sequence of operations of the three-position primary switch is arranged so that to ground the primary feeder the switch can be moved to the "Ground" position only from the "Transformer" position. This sequence of operations prevents grounding an energized feeder circuit because if the feeder is energized with the switch in the "Open" position, the interlock locks the switch when the switch is moved to the "Transformer" position where it must be before being moved to the "Ground" position. In some cases, such as when radial loads are served from the same primary feeders that serve network transformers, it is desirable to be able to disconnect a network transformer from an energized feeder. For that purpose the primary disconnecting switch must be capable of opening exciting current and must be so interlocked that it cannot be opened unless the associated protector on the low-voltage side of the transformer is opened to remove load from the transformer. A three-position switch for interrupting exciting current must have an additional interlock to prevent grounding an energized feeder circuit. A three-position primary switch is shown on the right end of each network unit in Fig. 9. The high-voltage switch compartment usually is combined with a terminal chamber or potheads for terminating the primary-feeder cables.

The Network Protector⁵⁶ is an electrically-operated air circuit breaker controlled by directional-tripping and voltage-reclosing relays. The breaker, the operating mechanism, and the relays are assembled together to form a self-contained unit that in many cases is bolted to a throat, enclosing the secondary terminals, on the network transformer. Such a protector is shown in Fig. 10 and on the left end of the network unit in Fig. 9.

The basic directional-tripping function and the over-voltage-reclosing function of the network relaying are combined in one three-phase relay⁵⁷ called the master

network relay. The master relay is mounted in the lower left corner of the protector, Fig. 10. This relay is a watt-type induction relay. The master relay closes its closing contacts when the protector breaker is open and the voltage of its associated transformer is slightly greater than and essentially in phase with the corresponding network voltage. The tripping contacts close when the protector is closed and a current in excess of the minimum setting of the relay flows through the protector from the network secondary mains to the transformer.

The overvoltage-closing function of the master relay is usually modified by a phasing relay⁵⁷ so that the protector does not close if the voltage of the transformer being connected to the secondary grid appreciably lags the network voltage. This insures that the network protector closes only if the relationship between the transformer voltage and network voltages is such that power flows toward the network when the protector closes and does not immediately reopen because of the resulting current flow being in effect a reversed current. The phasing relay is mounted directly above the master relay in the protector, Fig. 10.

It is desirable to have the network relays sensitive enough that the network protectors open on the exciting current of their associated transformers when the corresponding primary-feeder breaker is opened. This not only provides a simple means of periodically checking the operation of the network protectors but also makes it unnecessary to go to all the protectors associated with a particular feeder in order to deenergize the feeder for repairs. Another advantage of sensitive tripping is that the protectors can isolate single-line-to-ground faults on a circuit supplying the network, when the primaries of the network transformers are connected in delta. However, in infrequent cases, such as when regenerative loads are supplied from the network, sensitive tripping will result in too frequent operation of protectors. In these cases the sensitivity is decreased for normal conditions by means of a desensitizing relay.⁶⁸ This relay permits the protector to trip on small reversed currents only after a predetermined time-delay and on large reversed currents without intentional time-delay.

Primary Feeders—The primary feeders supplying a low-voltage network generally are radial circuits because the interconnection of the secondary mains and the operation of the network protectors provide means of maintaining service to all loads on the network independent of the loss of any one feeder. In underground systems the feeder circuits are usually lead-sheathed cables. Both three-conductor and single-conductor cables are used. Three-conductor cables frequently are used for the main feeders because of the lower cost. Single-conductor cables frequently are used for sub-feeders and laterals because single-conductor cables facilitate making the large number of splices and joints required on these sections of feeders.

The primary feeders to a secondary network may originate at a distribution substation, at a bulk power substation, or at a generating plant. The primary feeders should originate at the same substation or at substations that are closely tied together⁶² because the feeders are paralleled through the low-voltage secondary mains of the

network grid and angular voltage differences between primary feeders result in improper load division or cause a large number of protectors to open. Furthermore, if the feeders are supplied from more than one substation, it may be necessary to plan the network on the basis of one of a few substations instead of one of several feeders being out of service. For example, a network system supplied over four feeders from two single-transformer distribution substations (two feeders per substation) has to be designed to carry the total network load on half of the network transformers because of the probability of an outage of one substation. If all four feeders are supplied by one substation so arranged that power is always available at its low-voltage bus, it is reasonable to assume that the worst emergency condition is the loss of one of the four primary feeders. In this case three-fourths of the network transformers are always available to carry the total load. Much more reserve network transformer capacity is required in the former case than in the latter. If the feeders supplying network transformers originate at a distribution substation the subtransmission supply to that substation should be a subtransmission loop or grid and the substation should have duplicate transformers (See Chapter 20). The arrangement of the secondary network provides continuous service regardless of faults in network transformers or primary feeders. In practical operation the reliability of service from the secondary network is limited only by the reliability of power supply to the primary feeders supplying the network transformers.

In many areas where the secondary network is applicable the total load frequently is sufficient for two or more subtransmission circuits. Network transformers usually are three phase and range from 150 to 600 kva. The additional cost of using transformers rated for subtransmission voltages instead of for the lower voltages generally used for radial primary feeders is fairly small. These two factors make it economical to supply a secondary-network system over radial subtransmission circuits and thus eliminate the distribution substation. In this case there is only one voltage transformation between subtransmission voltage and utilization voltage. In many cases these subtransmission circuits originate at a generator bus. This makes a simple distribution system with a direct path from generators to consumer services.

Automatic reclosing generally is not used on underground supply circuits in a network system for two reasons. The first is that faults in cable circuits operating at more than 600 volts seldom clear when they are deenergized. The second reason is that in the network system it is not necessary to reenergize a supply circuit as quickly as possible to minimize service interruption because a supply circuit fault does not drop any network load. Furthermore, the network system allows a faulted supply circuit to be repaired deliberately, using as much time and taking whatever precautions are necessary to insure a good repair job, without interrupting load.

The secondary-network system is well adapted to bus-voltage regulation because the network load is divided almost equally among the feeders or subtransmission circuits supplying the network and consequently the same relationship between bus voltage and load voltage is satis-

factory for all the network supply circuits. Feeder-voltage regulation seldom is used because of voltage differences²² that may be introduced between feeders by the individual regulators. This is particularly true of three-phase induction regulators because they may introduce an angular displacement as well as an in-phase voltage difference. Furthermore, bus-voltage regulation is generally more economical. When network feeders are supplied from a generator bus, generator-voltage regulation can be used if the voltage variations required by the network loads are satisfactory for other loads served from the same generator bus.

12. The Overhead Network

The overhead secondary network³⁹ follows the same general pattern as the underground network and differs from the underground network primarily by having the secondary mains, network units, and in many cases the primary feeders overhead on poles. Extensions of the fringe of an underground network frequently are carried overhead in areas where underground construction is not used. The secondary mains are supported by racks or messenger cables. The network transformers and network protectors are mounted on poles or on platforms depending on the size of the network unit. In areas where overhead construction is used load densities are generally lower than in underground areas and the network transformers are correspondingly smaller. Transformer ratings most frequently used in overhead networks range from 50 to 150 kva. The network protectors⁴¹ used in overhead network systems are generally smaller than protectors for underground systems but operate in the same way. Overhead secondary-network main conductors are smaller than underground-network main conductors and faults are burned clear as they are in the underground network. When the secondary-main conductors are mounted in the open on racks in the overhead network, a definite spacing is maintained between the conductors and faults are more easily cleared than in underground mains. The fault currents required to clear faults on overhead secondary mains are shown in Table 2.

13. Operation of the Secondary Network

Normally all primary feeders of the network system are in operation and carry a proportionate share of the total network load according to the transformer capacity served by each feeder. Each load on the network is supplied by not less than two paths and the load inherently divides so that the best possible voltage is maintained at all points in the network grid. As loads change, the division of load changes so that equal voltage drop is maintained from adjacent transformers to every point on any interconnecting main. Thus, for any given load conditions the least possible voltage drop to services is obtained. Since there are at least two paths of supply to any load tap in the secondary grid, abrupt changes of load—such as starting large motors^{36,48}—cause less voltage disturbance in a network system than in a system having radial secondary mains, even if the radial system were designed for the same steady-load voltage drop as the network system.

Faults in Secondary Mains are burned clear as explained previously in the description of the network

secondary mains. Most of these faults either are arcs or have less thermal capacity than the secondary-main conductor; this type of fault is cleared quickly without interrupting loads. A few faults have high thermal capacity and must be cleared by fusing the conductor between the fault and adjacent junction points in the grid. Such faults may result in dropping all the load on one section of secondary main. However, such faults occur infrequently.

Primary-Feeder Faults are cleared by opening the breaker at the supply end of the faulted feeder and opening all the network protectors in network units associated with the faulted feeder. None of the load is dropped and the total load divides among the remaining feeders. When the faulted supply circuit is repaired it is returned to operation by closing its breaker. When the feeder is reenergized with the correct voltage, the protectors that opened because of the fault reclose and the feeder again carries its share of the load. A transformer fault is isolated in the same manner as a primary-feeder fault. If the transformer is equipped with a high-voltage disconnecting switch the faulted transformer can be switched off the deenergized feeder and that feeder can be returned to service. However, this is not necessary, if the transformer can be replaced in a reasonably short time, because the network system must be capable of carrying the total network load with any one feeder out of service.

Under emergency conditions with one feeder open the load is distributed among the network units supplied by the feeders remaining in operation. Under these conditions the voltage regulation at some points in the network, particularly those where a network unit is disconnected from the grid, will not be as good as under normal conditions. The amount by which the voltage drop under emergency conditions exceeds that for normal operation depends to a considerable extent on the uniformity of the load distribution among the network units during an emergency.

Load Division—The uniformity of load division among the network units for either emergency or normal operation depends on the ratio of the impedance of a section of secondary main to the impedance of a network transformer. The load division between transformer banks on a network generally is satisfactory if the ratio of main-to-transformer impedance is three or less and if the transformers are correctly selected as to size and properly located with respect to the major loads on the network. In general, load division under normal operating conditions has not proved to be a serious problem on network systems because, when enough transformer capacity is provided to prevent overloading with a primary circuit out of service, there is sufficient capacity to take care of the normal difference in loading of the banks. If in isolated cases a bank of transformers is carrying much more than its share of the load, this can be corrected by installing a larger bank, a duplicate unit, or external reactors²³ in series with the existing bank on the secondary side.

The choice of transformer impedance for the network unit depends on its effect not only on load division but also on fault currents, circulating currents, and voltage regulation. Other things being equal, the lower the impedance of the transformers the better the voltage regulation, the higher the fault currents, the higher the circulat-

ing currents between primary feeders, and the poorer the load division between transformer banks. Improved voltage regulation and, in most cases, higher fault currents to insure burning secondary faults clear favor the use of low-impedance transformers. High transformer impedances, such as seven to ten percent, have been used, particularly in early installations of the secondary network, to improve load division and to reduce circulating currents between banks at times of light load and the resultant undesirable network-protector operations. Circulating currents are caused by voltage differences between primary feeders, resulting from such factors as supplying the feeders from different buses, differences in feeder-voltage regulators, or tapping large radial loads off one or more of the network primary feeders. Relatively high impedance in the secondary mains between low-impedance transformers reduces the circulating current but results in poorer distribution of load between transformer banks, both under normal conditions and when one primary feeder is out of service, than would be the case if lower-impedance secondary mains were used. Generally a network-transformer

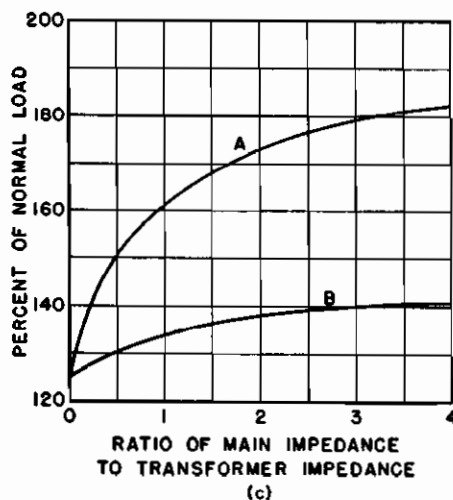
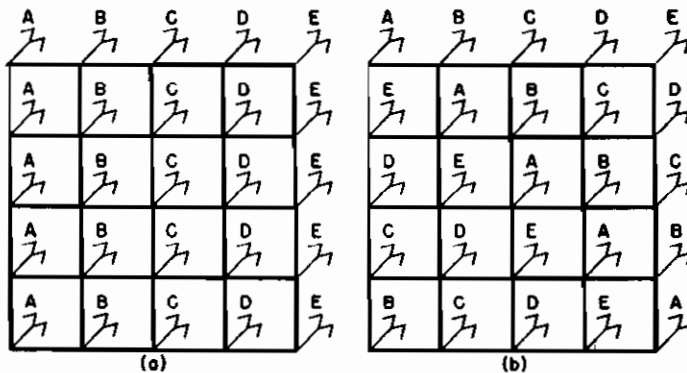

Fig. 11—Effect of interlacing primary feeders on load division among the network units remaining in service in a regularly spaced uniformly loaded network when one feeder is out of service. (a) Five feeders, A, B, C, D, and E, running parallel through the network area. (b) Five feeders, A, B, C, D, and E, interlaced in the network area. (c) Maximum load on any network unit with any one feeder, out of a total of five supplying the network, out of service: Curve A for parallel feeders and Curve B for interlaced feeders.

TABLE 3—RELATIONSHIP BETWEEN TRANSFORMER CAPACITY AND PEAK LOAD IN A SECONDARY-NETWORK SYSTEM

Number of Feeders	Ratio of Peak Load To Transformer Capacity	
	Ideal	Usually Attainable
2	0.50	0.40
3	0.67	0.54
4	0.75	0.58
5	0.80	0.60
6	0.83	0.61

impedance of about five percent provides satisfactory operating conditions. The majority of network transformers in operation have impedances ranging from four to six percent.⁶³ If an impedance outside this range appears desirable, the effect on voltage regulation and lamp flicker should be carefully considered.

Interlacing Supply Circuits—The maximum load on transformers in a network system when one feeder is out depends not only on the ratio of secondary-main impedance to transformer impedance but also on the pattern of the primary-feeder connections to the transformers in the network. This latter effect is illustrated in Fig. 11 for a uniformly loaded, regularly spaced network. Two extremes of primary feeder routing are shown in Figs. 11(a) and 11(b). One extreme is the parallel primary-feeder arrangement in which all transformers along one line of secondary mains are connected to one primary feeder as shown in Fig. 11(a). The other extreme is the interlaced primary-feeder arrangement in which each transformer connected to one feeder is surrounded by transformers, at adjacent junction points, that are connected to other feeders. The curves in Fig. 11(c) show that the maximum transformer load when one feeder is out of service is considerably less, for all practical impedance ratios, with interlaced feeders than with parallel feeders.

Ratio of Load to Transformer Capacity—In order to avoid overloading the transformers in a network it is necessary to provide enough capacity in the network units so that the maximum loading on any unit when one feeder is out of service does not exceed the capacity of the unit. The necessary installed capacity depends on how well the load divides among the units as determined by impedance ratio and feeder interlacing and on the number of feeders supplying the network. Under ideal conditions it is necessary to have twice as much transformer capacity as total load in a network served by two primary feeders, so that the network units served by one feeder can carry the total load when the other feeder is out of service. For networks supplied by six feeders or less it is reasonable to assume that not more than one feeder will be open at any time during peak load. Table 3 gives the ideal ratio of peak load to total transformer capacity in a network for two to six interlaced feeders. Increasing the number of feeders from two to three and from three to four improves the ideal ratio rapidly; but, as the number of feeders is increased further, the saving in transformer capacity decreases so that there is little gain in using six feeders instead of five. This is especially true for the ratio that usually can be attained. The ideal ratio can be realized only

if the transformers can be loaded exactly to their capacities and if the load divides uniformly among the units in service at any time. These conditions do not occur in practice and the ratio that actually is obtained is usually about that shown in the right hand column of Table 3. The ratio of total peak load to total transformer capacity of 121 networks in 1937 was 0.44.⁶³ This value is based on existing load and transformer capacity; the transformer capacity in the actual networks probably provides for some load growth beyond the existing loads. The factors in Table 3 are based on loads for which a network is designed and which include provision for load growth. If allowance is made for this discrepancy, the ratio of 0.44 is comparable to the average of the attainable ratios in Table 3.

14. Economic Field of Application

The simplicity of the secondary-network system is an economic advantage in many cases. In many distribution systems subtransmission circuits can be carried directly from bulk power stations to the distribution or network transformers. This means that a considerable saving can be made by eliminating the distribution substation normally required by other systems. Another source of savings results from eliminating the duplication of primary feeders or subtransmission circuits and the accompanying high-voltage switchgear required in radial systems to provide a high degree of reliability. Secondary copper can be saved in many cases because the interconnected grid eliminates the need for separate secondaries frequently required in radial systems for light and power loads. Capacity can be added in the secondary-network system in even smaller increments than in the primary network. The economic advantage of adding small increments, as explained in the discussion of the primary network system, is more pronounced for the low-voltage network than for the primary network.

The relatively large amount of secondary switchgear, in the form of network protectors, tends to make the installed cost of the network system higher than that of a radial system and counteracts part of the gain from the simplicity of the subtransmission and primary-feeder part of the secondary-network system. Interlaced primary feeders in the secondary-network system require more feeder circuit than do parallel feeders. They may require more feeder circuit than a radial system using duplicate feeders or primary switching to provide for isolating a faulted primary feeder or section of feeder. The additional feeder circuit required by interlacing usually is compensated for by the saving in network-transformer capacity. The use of primary switches in the network units counteracts some of the savings resulting from the elimination of many automatic breakers in the subtransmission circuits or primary feeders.

The low-voltage network generally has an economic advantage from the standpoint of operating costs. System losses are generally lower in the secondary network than in other systems of comparable load capacity chiefly because of two factors. One of these is the simplicity of the subtransmission circuits and primary feeders and, in many cases, the elimination of the distribution-substation transformers. The other factor is that, since there are at least

two paths of supply to each service tap, the load currents divide among the secondary mains in such a way that minimum losses are obtained for any given load condition. Maintenance and repair work on the system can be done under the most favorable conditions because any element in the system, except secondary mains, can be isolated from the system without interrupting any load. One operating disadvantage is the large number of network protectors that must be maintained.

The interconnected secondary grid places the duplication of supply paths as close as possible to the loads being served. For this reason the secondary-network provides better continuity of service than any other distribution system except the d-c network system. The high cost of the d-c network system eliminates it from consideration in the selection of a distribution system especially since it affords no greater reliability than the a-c secondary network. The grid arrangement of the secondary mains also provides the best possible voltage conditions at the loads consistent with economical system design. The voltage regulation at the service taps on a secondary network system generally is better than that provided by other systems. This is particularly true from the standpoint of lamp flicker because abrupt load changes can divide between at least two paths of supply.

Generally if high quality of service is required in any load area the secondary-network system is the most economical means of supplying power. Under certain conditions the secondary-network system is the most economical system even when a high degree of reliability is not necessary. This is generally true where the entire distribution system is underground because a radial system requires many switching and sectionalizing devices and duplication of subtransmission circuits and primary feeders to avoid long interruptions of service while cable circuits are being repaired. Faulted overhead circuits usually can be returned to service in a reasonably short time, but a much longer time is required to locate and repair a fault in a cable circuit. The economic comparison¹³ of typical distribution systems shown in Fig. 4 shows that if all distribution circuits are open-wire the overhead network is likely to be the least expensive system for uniform load densities above about 3000 kva per square mile. A similar comparison⁴⁰ of systems in a uniformly loaded area where all subtransmission and primary circuits are underground, as shown in Fig. 12, indicates that in such load areas the overhead network (Curve E), may be economical for load densities above about 3600 kva per square-mile. The comparisons shown in Figs. 4 and 12 are based on an area of sixteen square miles in which the load is assumed to be uniformly distributed and to grow uniformly at a constant rate of ten percent per year. Although such uniform conditions do not occur in actual cases the comparisons show trends that are likely to occur in actual cases. In actual cases the load generally is not uniformly distributed and the load growth usually varies from year to year and from section to section. The fact that the secondary network can be expanded in small increments is of greater advantage under such conditions than under uniform load conditions, as explained in connection with the primary-network system (See sections 6 and 7). This factor is

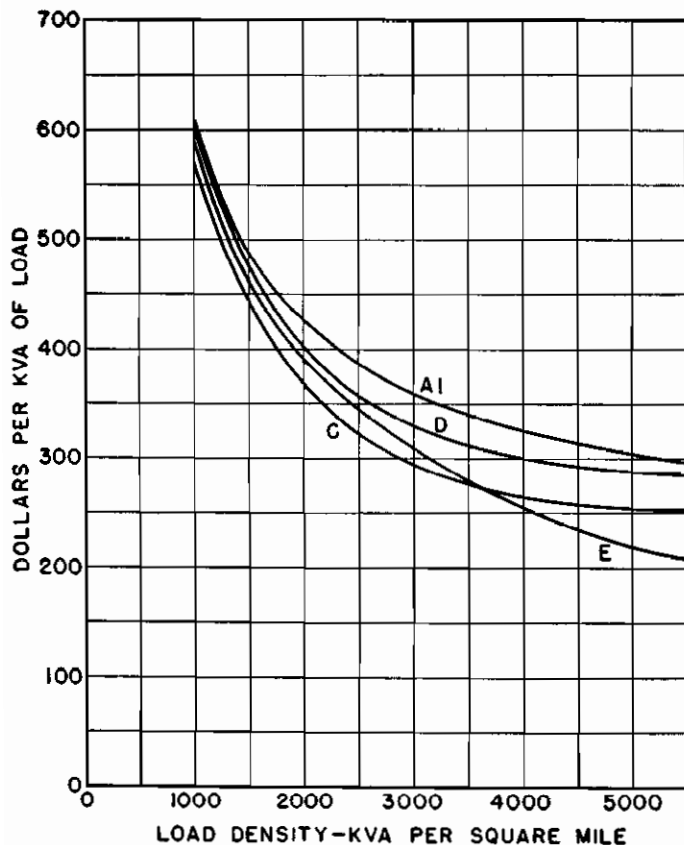

Fig. 12—Relative cost of several types of distribution systems, for various load densities in a sixteen-square-mile area where the uniformly distributed load grows ten percent per year, on the basis of all subtransmission and 4-kv primary feeders underground and secondaries overhead. See Fig. 4 for the type of system represented by each curve.

even more important in the secondary network than it is in the case of the primary network because the secondary-network units are smaller than those in the primary network and system capacity can be changed in correspondingly smaller increments.

15. Planning the Secondary Network

The planning of a network system is not as straightforward as that of a radial system but the procedure is relatively simple.⁷¹ The ideal method is to use a calculating board because it is practically impossible to calculate the characteristics of a network by other means. As in any planning problem, it is necessary to have adequate information (loads, available supply, existing facilities, and available circuit locations) on which to base the design of a network. With this information available the procedure then is to lay out by estimation an apparently feasible plan. This plan is then studied on a network calculator or by inspection and revised until a good design is obtained.

Preliminary Estimates—In a radial system primary and secondary circuits can be laid out and regulation, transformer capacity, and circuit capacity can be calculated directly by arithmetical means. This is not true in the case of the network because the loads divide among

the various transformers and primary circuits in such a way that calculations of the characteristics of the system by ordinary methods become tedious. There are two general methods of planning a network system. One is to use a network calculator or a miniature system⁶⁷ to determine the characteristics of an estimated system arrangement and then make such revisions as are required. The other method is to estimate a plan and then by inspection estimate the division of load for various conditions; the plan is then revised until the estimated load division gives satisfactory conditions. The first method is more satisfactory because it shows accurately the operating characteristics of the plan being considered while the accuracy of the estimation-by-inspection method can be determined only after the system has been installed. The network-calculator method is described briefly in the following paragraphs.

The first step is to concentrate the loads, in the proper units, at various points throughout the network so that a reasonable number of circuit elements can be considered. In order to do this the secondary-main arrangement that appears best should be drawn. This step is illustrated by the mesh of solid lines in Fig. 13 for a section of a typical network area. The numbers distributed inside the dotted building areas in Fig. 13 are present loads at service points and are in terms of diversified kilowatt demand at the distribution transformers. After the secondary grid is drawn the distributed loads along each section of main are concentrated at the junction points. A good approximation is to divide each load between the adjacent junctions in inverse proportion to the distances between the load and the junctions. After these loads are concentrated at junction points they are converted to ultimate kva of diversified demand, at the transformers, for which the network is to be designed. In the typical example the present loads are increased by a factor of 1.4, providing for 25-percent load growth (or approximately seven percent annually for three years) and converting from kilowatts to kva at 90-percent power factor. The loads are then of such size and so located that they can be represented on a network calculator conveniently, and they accurately represent load conditions in the network area for which the network must be designed. Where a large individual load is served from a point along a section of main it is preferable to consider that load at that point and possibly locate a transformer adjacent to the load, even if there is no junction with other secondaries. This condition is illustrated at point *e* in Fig. 13. The load near some points, such as *i*, may be so light that a concentrated load need not be considered but secondary mains should be provided to insure good load division among the various parts of the network for emergency conditions.

The layout of the secondary grid is made on the basis of the locations of the loads that must be served and the routes of existing secondary mains. In most cases existing secondaries almost completely cover the area and it is only necessary to connect these secondaries into a continuous grid. In some places it may be desirable to add sections of main to provide multiple paths to certain loads for emergencies when adjacent transformers are out of service.

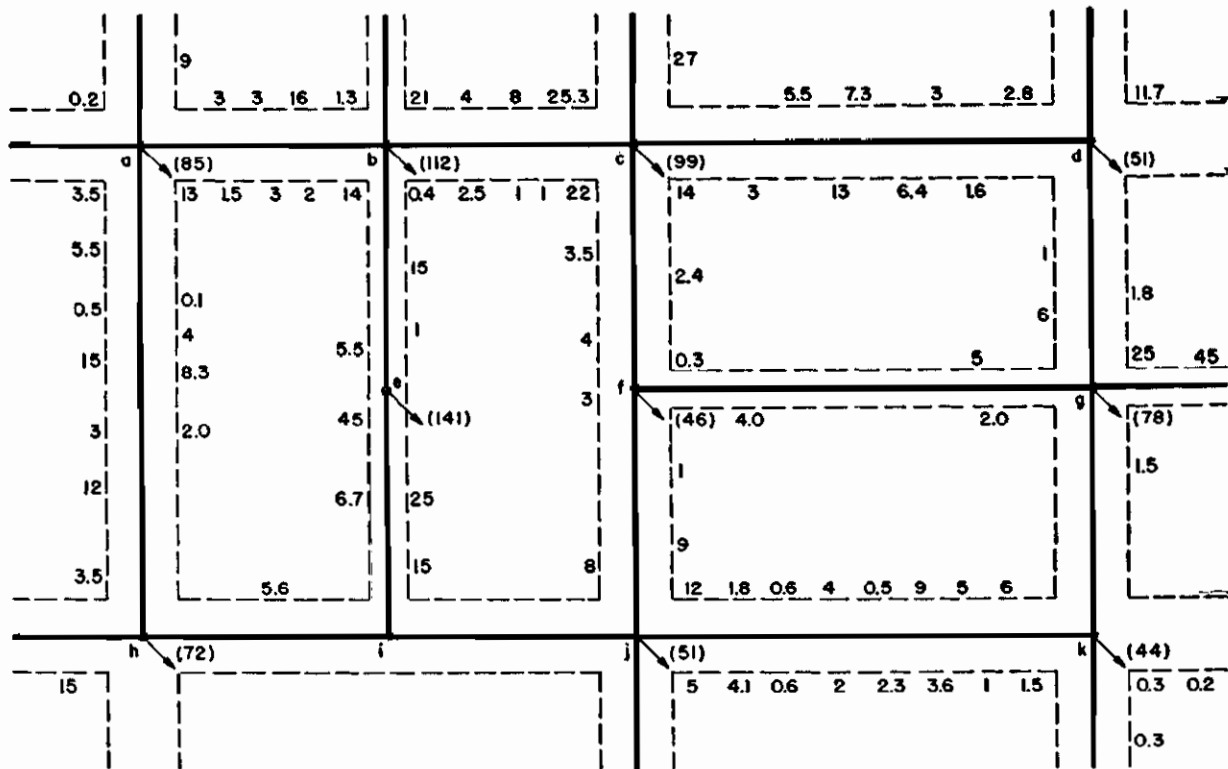

Fig. 13—Present distributed loads along the secondary main, in terms of kw of diversified demand at the distribution transformer, and the corresponding concentrated loads at the intersections of the mains, in terms of diversified kva demand including estimated load growth, form the basis for designing a secondary network in a typical load area.

When the loads and secondary plan have been determined the approximate sizes and locations of transformers can be selected. The transformer size will depend on the type of system, size of concentrated loads, number of feeders available, the feeder interlacing obtainable, and spacing of the transformers. In general, the larger the transformer the lower the cost per kva and the wider the spacing between transformers in the network. But as this spacing is increased the secondaries must be larger to keep secondary voltage drop within reasonable limits and to provide adequate carrying capacity. As the number of transformers is reduced less primary cable is required. The ideal size of transformer then is that which not only handles the loads but also gives a minimum total cost including costs of primary feeders, transformers, and secondary mains. In the initial trial plan for the network the transformers should be located at the major loads and at the various junctions where the concentrated loads are large enough so that the distance between transformers is not greater than about two blocks or 600 to 800 feet. Usually the spacing is less than this because of the locations of loads. It is generally desirable to select not more than two sizes of network transformers. This permits stocking fewer spare transformers and protectors. Also, interchangeability of units and parts is increased by using only one or two sizes. At points where large concentrated loads are served it is desirable to use multiple installations consisting of two or more transformers rather than one transformer much larger than the rest of the units. This avoids a large number of sizes and the use of a few units of a size that is not interchangeable with any of the predominating

sizes. In addition, multiple unit installations improve load distribution and voltage regulation at the large loads for emergency conditions.

After tentatively selecting sizes and locations of transformers a size of secondary main is selected. This size depends on the required carrying capacity, estimated regulation, and size of existing secondary copper. The carrying capacity should be adequate to carry one-half to two-thirds of the rated capacity of the predominating size of transformer. The voltage regulation for normal operation can be estimated by calculating the voltage drop to the distributed loads along some sections of main where inspection indicates the worst regulation is likely to prevail.

The primary-feeder connections to the various transformers must be carefully selected to avoid, if possible, adjacent transformers being out of service when any one feeder is open. This is accomplished by interlacing the primary feeders. In a network plan where the transformers are spaced regularly and uniformly throughout the area the interlacing of feeders, such as A, B, C, D, and E, can be shown in Fig. 11(b). In actual interlacing problems the network units are seldom regularly spaced. However, the interlacing is simplified by using some basic system, such as that illustrated in Fig. 11(b) and modifying the order of the feeder connections where necessary because of the absence of a transformer or the use of multiple units. When the interlacing has been selected, a map of primary feeder routings is made. It may be possible to change some of the feeder connections to save feeder cable and still retain good interlacing.

By means of the preliminary estimates the location and

ratings of transformers, feeder interlacing, secondary-grid arrangement, and secondary-copper size are selected so that a reasonable network plan is established. This plan can then be simulated on the network calculator on the basis of the impedances of the various circuit elements. The impedance of the primary feeders is usually low enough that its effect on the characteristics of the network is negligible. The impedance of a primary feeder is usually not larger than about 0.5 percent on the basis of the rating of the largest network transformer or about one-tenth of the impedance of the transformer. Every case should be checked and if the primary-feeder impedance exceeds this value it may be necessary to consider the impedance. Whether or not the primary-feeder impedance is considered also depends on the primary-voltage regulation. If the drop in the primary can be compensated for so that approximately constant primary voltage is maintained at the primary terminals of the network transformers the primary-feeder impedance should not be considered in load studies.

Checking the Preliminary Plan—With the estimated plan set on the network-calculator, check studies can be made to determine the accuracy of the preliminary estimates. It may be necessary to change transformer capacities or locations, interlacing, or secondary copper to avoid overloading or inadequate use of some elements of the network. Then with a final plan determined, the characteristics of the network can be completely and accurately determined by means of the network calculator.

All reasonable operating conditions should be investigated. For example, the load division among the network units should be determined with each primary feeder out of service. Typical load division results obtained from the network calculator are shown in Fig. 14 for the typical area for the case when feeder "A" is open. By means of the network calculator the maximum load on any element of the network, the voltage regulation under various conditions, and the available fault currents can be determined. These data show whether any of the elements of the network are overloaded and whether secondary faults can be cleared. Necessary revisions of the plan can then be made

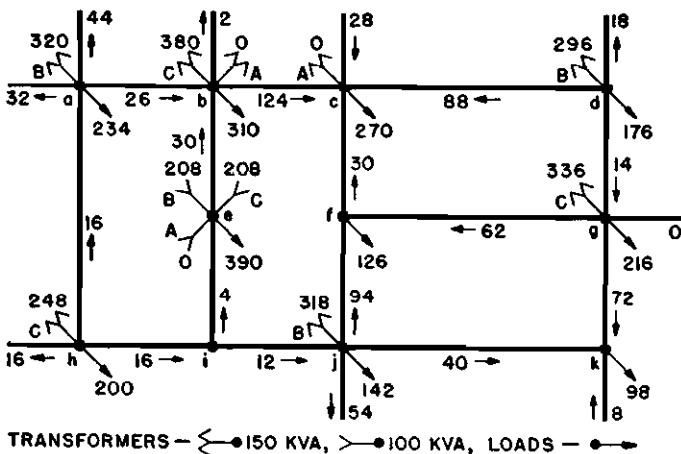
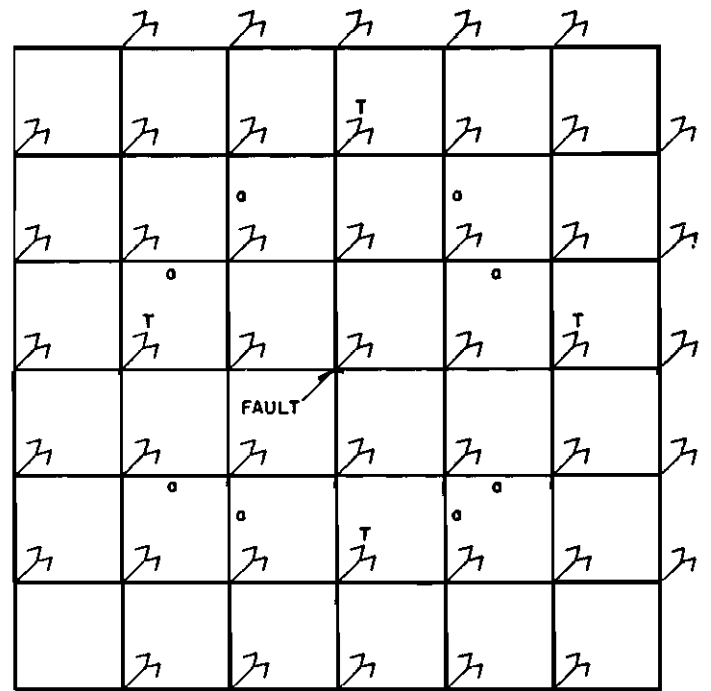
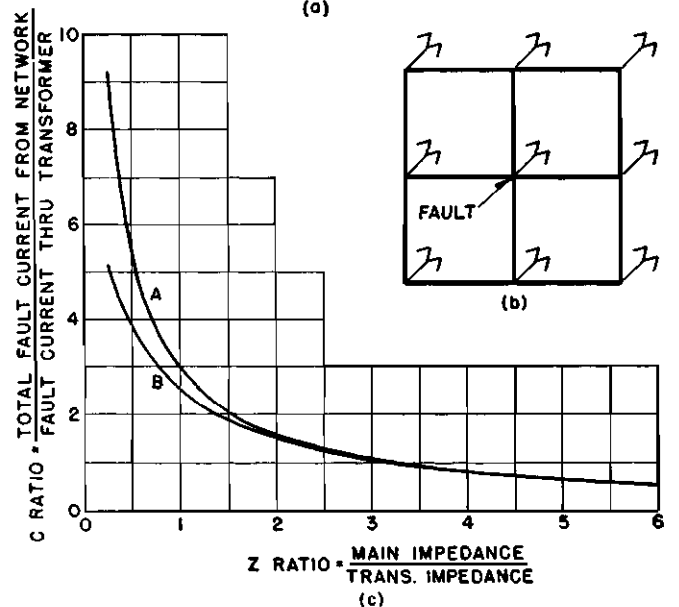

Fig. 14—Loads in amperes in various elements of a typical section of a secondary network in an emergency when feeder A is out of operation.



(a)



(b)

(c)

Fig. 15—Short-circuit currents in regularly spaced network for various ratios of the impedance of a section of secondary main to the impedance of a network transformer. (a) An extensive network having 45 network transformers all with the same rating. (b) A small network having nine transformers all with the same rating. (c) Ratio of total fault current from the network to the short-circuit current of one of the network transformers for a solid three-phase fault at the secondary terminals of the transformer at the center of the network. Curve A is for the network shown in (a) and Curve B is for the network shown in (b).

and a workable design developed. The sum of the loads on the transformers connected to any primary feeder indicates the required capacity in that feeder.

The network calculator provides the best means of determining the fault currents in a network. However, if approximations are necessary, the curves in Fig. 15(c) show

the current to a fault at the center of large and small networks having regularly-spaced equal-capacity network units. The curves give the ratio of the total current from the network to the short-circuit current of a network transformer. As indicated by the curves the ratio increases as the ratio of secondary-main impedance to transformer impedance decreases. Total current from the network does not include the current from the transformer at the fault point. The total fault current from the network divides equally among the four secondary mains terminating at the faulted junction point. One or the other of the arrangements shown in Fig. 15(a) or 15(b) usually approximates the actual network arrangement where fault currents are to be estimated. To use the curves it is first necessary to determine the average impedance of the network-main sections surrounding the fault point. The ratio of this impedance to the impedance of a transformer in the actual network is the entry point to the curve for determining the C ratio of the network, Fig. 15 (a) or (b), that approximates the actual network. Multiplying the short-circuit current of the transformer, whose impedance is the basis of the main-transformer impedance ratio, by C ratio gives the total fault current supplied by the network. In a network having only one size of transformer the impedance and short-circuit current of that size transformer is used for calculating fault currents. If there is more than one size of transformer in the actual network the predominating size is used. The fault currents determined in this way are correct only for a network arrangement like that in Fig. 15(a) or 15(b) for which the C ratio is determined. The effect of minor deviations from the regularity of the arrangement will depend on how close the deviation is to the fault point. The effect of deviations remote from the fault point is indicated by the fact that each main *a*, Fig. 15(a), carries 3.5 percent of the total fault current from the network when the impedance ratio is 0.5 and a smaller percentage when impedance ratios are higher. Each transformer *T* supplies less than three percent of the fault current from the network for any impedance ratio.

16. Special Applications

The high degree of reliability, the simplicity of operation, and the economy of the secondary-network system are desirable in several special cases such as in large or multi-story buildings, bulk loads where continuity of service is important, in generating plants for supplying auxiliary motors, and in industrial plants. The application of the secondary network in some of these cases involves modifications of the network system but the basic principles of operation remain unchanged.

Building or Vertical Networks—Fire pumps, elevators, and similar services in tall buildings require a high degree of reliability that can be provided most economically by a secondary-network system.^{30,34,38} Such buildings are almost invariably located in an underground-network area. Network units are located at several levels according to the location and size of the major loads in the building. The primary feeders or subtransmission circuits that supply the street network surrounding the building are extended up through the building to the various network

units. The network units in the building are interconnected by secondary ties that usually are connected to the secondary-network grid in the streets adjacent to the building. In some cases the secondary ties between the network units in the building do not serve any loads and the loads on the various floors between network units are supplied by short radial services from the network units. In other cases the tie circuits are tapped to serve the loads on the floors between network-unit locations. The tapped secondaries may have to be somewhat larger than untapped ones because the tapped ties have to supply loads as well as equalize the loads on the various network units. However, tapping the secondary mains between the network units eliminates the radial service circuits required when the ties are not tapped.

The secondary network uses considerably less copper than does a radial system because power is carried to the various levels in the building over subtransmission or primary-feeder circuits instead of over large low-voltage services from secondary mains outside the building. Furthermore, the network generally provides better voltage

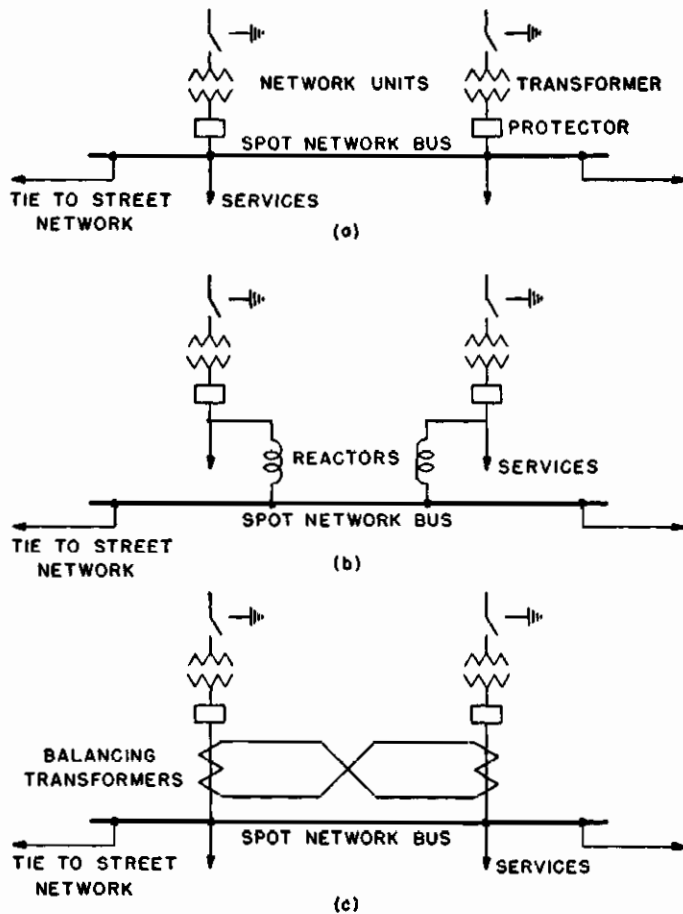

Fig. 16—Typical spot networks. (a) Two network units supplying a spot network bus from which services are tapped. (b) Two network units connected to spot-network bus through reactors. Services are supplied directly from terminals of network units. (c) Two network units supplying a spot-network bus through balancing transformers. Any of these forms of the spot network may or may not be connected to the secondary mains of a street network.

conditions, particularly in the upper floors of the building, and less loss because of the reduction in the length of low-voltage, high-current circuits. The secondary network utilizes all the diversity among the loads in the building to reduce the circuit and transformer capacity required to supply the building load.

The Spot Network is frequently used to supply a concentrated load such as a theater, a hospital, or a small industrial plant where a high degree of reliability of service is necessary.⁴² In its simplest form a spot network is a bus to which power is supplied by two or more network units, each of which is supplied by a separate primary feeder or subtransmission circuit, Fig. 16(a). The operation of the spot network is the same as that of the ordinary network. Instead of an interconnected grid of secondary mains the spot network uses a concentrated bus from which the loads are served.

Since a spot-network is a relatively low impedance path between the associated supply circuits large circulating currents through the spot-network units, frequent protector operations, or extremely unequal load division among the spot-network units may result from large voltage differences between the supply circuits because of other loads on those circuits. The most common methods of reducing circulating currents and equalizing load division are shown in Figs. 16(b) and 16(c). Reactors²³ are relatively inexpensive but their use depends on the practicability of dividing the load into parts approximately proportional to the transformer capacities. Because the network units usually are of equal rating the loads on the services must be nearly equal. In the scheme shown in Fig. 16(b) the voltages at the services are not necessarily equal and each service must be metered separately. Totalizing the loads, where that is necessary, requires complicated equipment. Starting large motors on one of the services is more likely to cause lamp flicker in the scheme in Fig. 16(b) than in a scheme where the services are supplied from a common bus.

To avoid the difficulties involved in the use of reactors, balancing transformers²⁷ frequently are used as shown in Fig. 16(c) although they are more expensive than reactors. The balancing transformers operate like differentially connected current transformers in the secondary leads of the network units. Equal load currents in the leads of the network units induce voltages in the differentially connected secondary windings of the balancing transformers. These voltages add and cause a circulating current in the balancing-transformer secondaries. This circulating current is in such a direction in each transformer that it essentially neutralizes the magnetomotive force due to the load current flowing through the primary winding of each balancing transformer, and there is practically no voltage drop in the balancing-transformer primary windings to oppose the flow of load current. If only a circulating current flows in the secondary leads of the network units, that is, toward the spot-network bus from one unit and from the bus to the other network unit, the voltages in the balancing-transformer secondary windings oppose each other. Therefore, there is no current in the balancing-transformer secondaries, and there is a large voltage drop in the balancing-transformer primaries opposing the flow

of circulating current through the network units. The secondary winding of a balancing transformer must be short circuited, when its associated network protector opens, to prevent high voltage drops in other balancing transformers interconnected with the balancing transformer whose primary circuit is open.

The use of balancing transformers permits taking services from a common bus. It is not necessary to have equal loads on the services. The service loads can be totalized by current transformers and simple metering equipment using the common bus potential. Motor starting currents and similar abrupt loads divide between the network units thus reducing the likelihood of lamp flicker. Balancing transformers are generally used only when circulating currents and consequent protector operations are likely to occur frequently because of voltage differences between the circuits supplying the network units. Inequalities of load division among the network units usually do not justify balancing transformers because sufficient network-unit capacity must be installed so that the total load can be carried with one unit out of service.

When a spot network is located in a secondary-network area the spot network bus is frequently tied to the street mains of the surrounding secondary network as shown in Fig. 16. This may improve the reliability of the spot network. It takes advantage of diversity between the spot-network load and the loads on the surrounding network to reduce the capacity required in the spot network.

Power-Plant Networks—The continuous operation of a steam generating plant depends not only on the reliability of the generators and boilers but also on the reliability of the auxiliaries such as draft fans, fuel handling equipment, boiler-feed pumps, and cooling-water pumps. Therefore it is extremely important that the power supply for the motors driving the auxiliaries be as reliable as possible. Many schemes are devised to improve the reliability of the power supply to the auxiliaries. These schemes use duplicate buses, duplicate transformers, throw-over switching, and various other devices. In many cases a secondary network is ideal not only from the

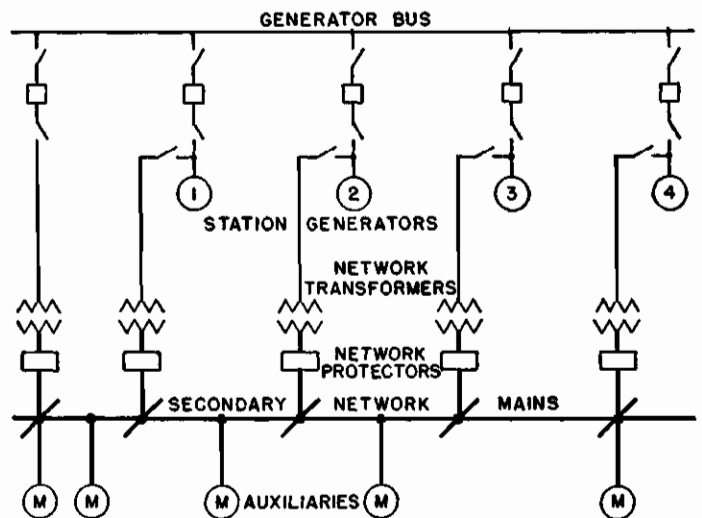

Fig. 17—Typical schematic diagram of a secondary network for supplying power-plant auxiliaries.

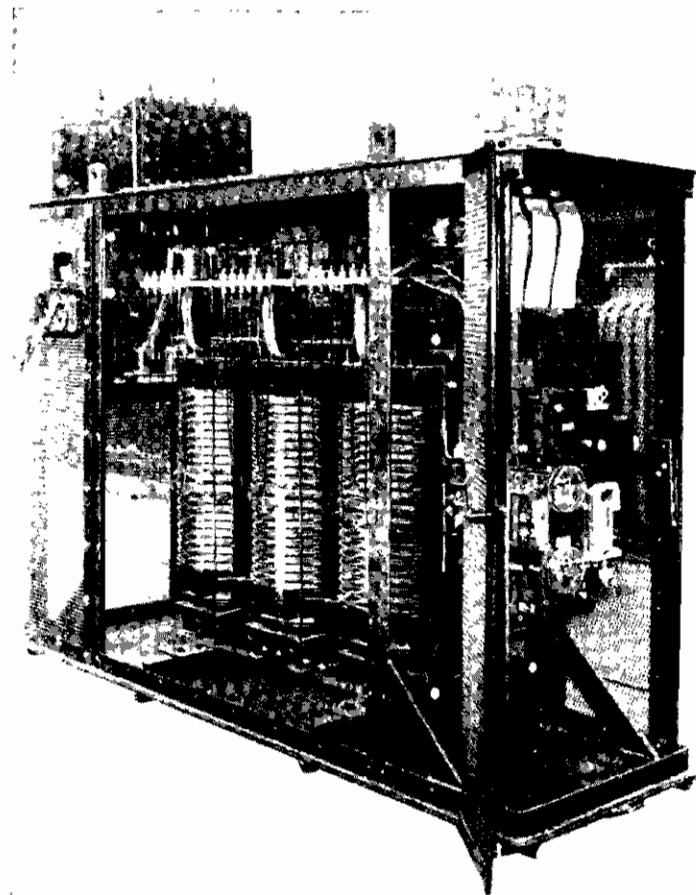

Fig. 18—A low-voltage network unit consisting of an air-cooled transformer, a high-voltage three-position selector switch, and a network protector for use in industrial plants, generating plants, and buildings.

standpoint of service reliability but also from the standpoint of economy.^{60,70} A typical arrangement of the network system for supplying power-plant auxiliaries is shown in Fig. 17. The network mains are carried through the plant according to load locations and the loads are supplied from these mains. The network units are distributed along these mains in accordance with the distribution of load. Two or more primary feeders are used to energize the network transformers.

It is necessary to have two or more circuits supplying the network. To avoid using a breaker to connect each of the primary feeders of the network to the plant bus where the interrupting duty and the corresponding breaker cost are high, the primary feeders frequently are connected to the generator terminals as shown in Fig. 17. The hazard of a fault in a short primary feeder and the associated network unit or units usually is small enough that it does not jeopardize the operation of the generator. However, there must be at least one network supply circuit connected to the station bus or an outside source of power so that the plant auxiliaries can be energized when all the generators are idle. The network protectors associated with a feeder supplied from the terminals of a generator must be interlocked with the generator breaker so that when the breaker is open the protector is locked open.

Otherwise the protectors may close and attempt to parallel a generator with other generators through the network system.

The utilization voltage for power-plant auxiliaries usually is nominally 440 volts. Since faults on circuits operating at that voltage frequently do not clear without being deenergized, limiters are connected in the secondary mains of a secondary network operating at that voltage. The auxiliary load in a generating plant is highly concentrated and consequently the possible short-circuit currents in a power-plant secondary-network system are usually much higher than in the ordinary street network.

Small Towns—In the commercial areas of small residential towns it is sometimes necessary to put the distribution circuits underground. Under these conditions the secondary-network system has been applied in many places where the load involved is only a few hundred kva.⁵⁵ These installations generally use light-duty network protectors and network transformers ranging in capacity from 50 to 150 kva. These small networks are usually supplied by only two primary feeders; in fact the supply circuits for the network units usually are subfeeders from overhead primary feeders that supply adjacent residential areas. In some cases the voltage level on one of the feeders is maintained enough higher than the other that the protectors associated with the other feeder are open under normal-load conditions and close only when the feeder with the higher voltage goes out of service or when an unusually high load peak occurs on the network.

Industrial Plant Networks—The secondary-network system, Fig. 19, has been used to distribute power in industrial plants^{60,70,72} where a high degree of reliability and flexibility for load changes frequently are required. The utilization voltage most frequently used in industrial plants is a nominal voltage of 440 but it may be 220 or 550. For the voltages above 220 some means of isolating faulted secondary tie circuits is necessary because faults at those

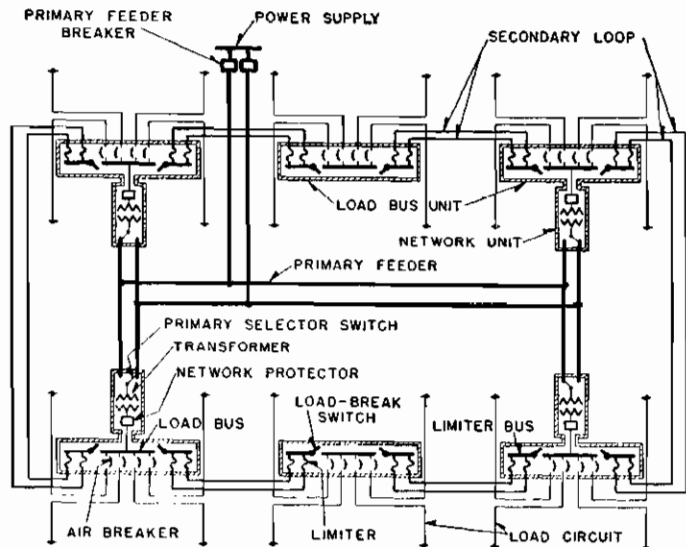

Fig. 19—Typical schematic diagram of a secondary network for distributing power in an industrial plant.

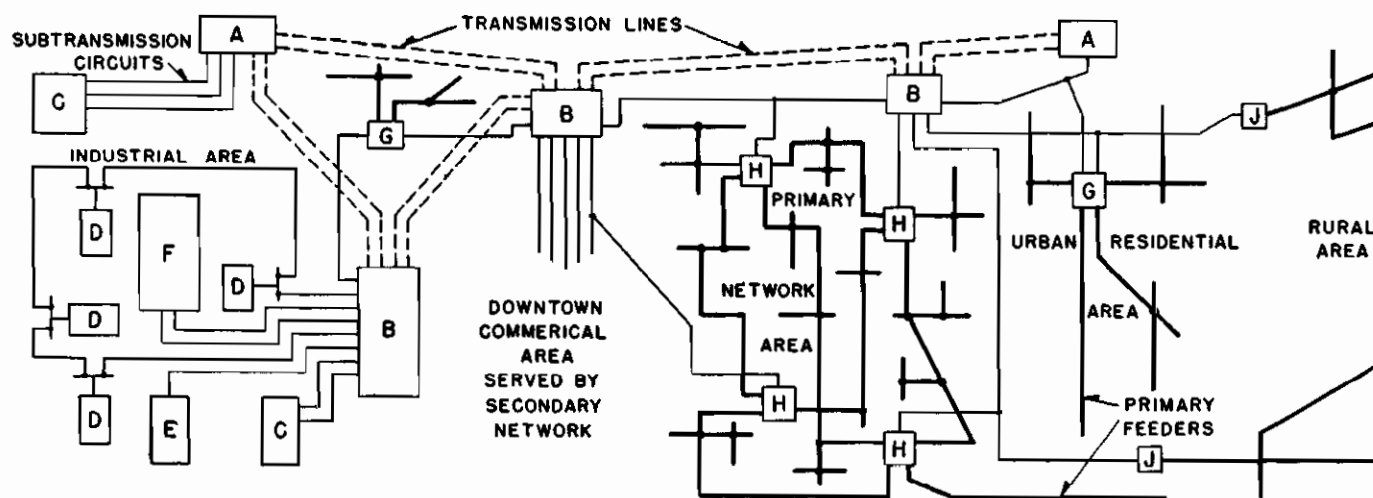

Fig. 20—A complete power system is a combination of generation, transmission, and several types of distribution systems. The particular combination of distribution systems used in any power system depends on economics and the types of loads, load densities, and quality of service required in local areas. In this diagram A is a generating plant, B is a bulk power substation; C is a plant where an industrial-plant network is applicable; D is an industrial plant served by a subtransmission loop; E is a plant served by a single subtransmission circuit; F is a plant served by duplicate subtransmission circuits; G is a distribution substation supplying radial primary feeders; H is a primary-network unit substation; J is a single-circuit distribution substation supplying a primary feeder in a rural area.

voltages frequently do not burn clear. Furthermore, the arcing and noise accompanying a secondary fault that burns clear are likely to disturb the personnel in a plant where the secondary ties usually are overhead in conduit or similar enclosures. Therefore, limiters or similar protective devices should be used in the secondary ties of an industrial-plant network as shown in Fig. 19.

One modification of the secondary-network system for industrial-plant applications is the use of a secondary loop instead of a grid. The load density in an industrial plant is high compared to that in urban areas where networks are applied. For that reason the transformer capacity and the corresponding fault current available is much higher in an industrial-plant network system than that in street networks. Omitting cross ties in a plant network and using a simple loop for the secondary ties reduce the available fault current. The use of parallel circuits in the loop sections facilitates selective operation of the limiters for isolating secondary faults.

Another modification of the network system generally used in the industrial-plant applications is a primary selector switch by means of which each network unit can be connected to either of two feeders. Frequently the total load on a plant network is not enough to justify more than two feeders. On the basis of street-network design this requires about two units of transformer capacity for each unit of load. By using the selector switch the transformer normally supplied by a faulted feeder can be switched to a good feeder, thus keeping all the transformer capacity in operation. It is necessary to have only enough reserve transformer capacity to permit any one transformer to be out of service because of a fault or for maintenance. In an industrial plant where the transformers are all in a small area the switching can be done quickly enough that the thermal capacity of the transformers permit them to carry the overload that occurs while the deenergized transformers are being switched back into service.

REFERENCES

General

1. *Overhead Systems Reference Book*, National Electric Light Association, New York, 1927.
2. *Electrical Distribution Engineering*, Howard P. Seelye, McGraw-Hill Book Company, Inc., New York, 1930.
3. *Underground Systems Reference Book*, National Electric Light Association, New York, 1931.
4. *Electric Distribution Fundamentals*, Frank Sanford, McGraw-Hill Book Company, Inc., New York, 1940.

Primary Networks

5. 4-KV Network Saves 20 Per Cent, A. H. Sweetnam, *Electrical World*, Vol. 97, March 14, 1931, pages 500-503.
6. Fundamentals of the Medium-Voltage Network, D. K. Blake, *General Electric Review*, Vol. 34, April, 1931, pages 210-216.
7. The Primary Network, R. M. Stanley and C. L. Sinclair, *A.I.E.E. Transactions*, Vol. 50, No. 3, September, 1931, pages 871-879, (discussion 879-884).
8. Protecting A Medium-Voltage Network, John S. Parsons, *Electric Journal*, Vol. 28, September, 1931, pages 520-525.
9. The Primary Network System, H. Richter, *Electric Journal*, Vol. 28, December, 1931, pages 661-664.
10. Primary Network Stations—Vault, Building, Outdoors, R. J. Salsbury and H. S. Moore, *Electrical World*, Vol. 100, September 3, 1932, pages 304-307.
11. Year of Experience Solves Primary Network Problems, R. J. Salsbury and H. S. Moore, *Electrical World*, Vol. 100, November 5, 1932, pages 624-626.
12. Short Circuit Tests Prove Primary Network, R. J. Salsbury and H. S. Moore, *Electrical World*, Vol. 100, December 24, 1932, pages 849-851.
13. Primary Network Economical For Medium-Load Densities, John S. Parsons and Leonard M. Olmsted, *Electrical World*, Vol. 101, June 24, 1933, pages 835-838.
14. Primary Network Proves Advantageous in Boston, St. George T. Arnold, *Electrical World*, Vol. 112, August 26, 1939, pages 590-592 and 648.
15. Simplified Primary Network Saves \$110,160 on Investment, F. W. Floyd, *Electric Light and Power*, Vol. 18, November, 1940, pages 47-49.

Secondary Networks

16. Underground Alternating Current Network Distribution for Central Station Systems, A. H. Kehoe, *A.I.E.E. Transactions*, Vol. 43, June 1924, pages 844-853, (discussion pages 869-874).
17. Motor Performance on Combined Secondary Networks, A. P. Fugill, *Electric Journal*, Vol. XXII, July, 1925, pages 316-320.
18. Evolution of the A.C. Network System, H. Richter, *Electric Journal*, Vol. XXII, July, 1925, pages 320-336.
19. Recent Development in Automatic Network Units, G. G. Grissinger, *Electric Journal*, Vol. XXII, July, 1925, pages 336-338.
20. The Automatic Network Relay, J. S. Parsons, *Electric Journal*, Vol. XXII, July, 1925, pages 339-344.
21. Regulators For Network Distribution Systems, E. E. Lehr, *Electric Journal*, Vol. XXII, July, 1925, pages 344-345.
22. Regulators on Network Feeders, C. C. Hudspeth, *Electric Journal*, Vol. XXII, July, 1925, pages 346-347.
23. No-Winding Reactors For Paralleling Transformers and For Secondary Networks, J. S. Hebrew, *Electric Journal*, Vol. XXIII, June, 1926, pages 329-332.
24. Evolution of the Automatic Network Relay, John S. Parsons, *A.I.E.E. Transactions*, Vol. 45, November, 1926, pages 1195-1202, (discussion pages 1220-1227).
25. Operating Requirements of the Automatic Network Relay, W. R. Bullard, *A.I.E.E. Transactions*, Vol. 45, November, 1926, pages 1203-1211, (discussion pages 1220-1227).
26. Combined Light and Power Systems for A.C. Secondary Networks, H. Richter, *A.I.E.E. Transactions*, Vol. 46, February, 1927, pages 216-234, (discussion pages 234-239).
27. Low-Voltage AC Networks, D. K. Blake, *General Electric Review*, Vol. 31, February, March, April, May, August, September, and November, 1928, pages 82-84, 140-143, 186-190, 245-248, 440-443, 480-482, and 600-604, and Vol. 32, March 1929, pages 170-173.
28. Developments in Network Systems and Equipment, T. J. Brosnan and Ralph Kelly, *A.I.E.E. Transactions*, Vol. 48, No. 3, July, 1929, pages 967-975, (discussion pages 975-976).
29. Low-Voltage AC Networks of the Standard Gas and Electric Company's Properties, R. M. Stanley and C. T. Sinclair, *A.I.E.E. Transactions*, Vol. 49, No. 1, January, 1930, pages 265-279, (discussion pages 280-284).
30. Vertical Distribution In World's Tallest Structure, J. A. Walsh, *Electrical World*, Vol. 97, February 14, 1931, pages 328-334.
31. Burn-Off Characteristics of AC Low Voltage Network Cables, G. Sutherland and D. S. MacCorkle, *A.I.E.E. Transactions*, Vol. 50, No. 3, September, 1931, pages 831-844, (discussion pages 845-846).
32. Arcs in Low-Voltage AC Networks, J. Slepian and A. P. Strom, *A.I.E.E. Transactions*, Vol. 50, September, 1931, pages 847-852, (discussion pages 852-853).
33. The Philadelphia AC Network System, H. S. Davis and W. R. Ross, *A.I.E.E. Transactions*, Vol. 50, No. 3, September, 1931, pages 885-891, (discussion page 891).
34. Vertical Networks in Metropolitan Office Buildings, A. H. Kehoe and Bassett Jones, *A.I.E.E. Transactions*, Vol. 50, No. 3, September, 1931, pages 1159-1164.
35. Starting Currents on Networks, L. C. Bell, *Electric Journal*, Vol. 28, 1931, pages 615-617.
36. Reducing Network Protector Operation, J. S. Parsons, *Electrical World*, Vol. 98, December 5, 1931, pages 1010-1013.
37. Network Balancing Transformers, R. E. Powers, *Electric Journal*, Vol. 29, February, 1932, pages 89-92.
38. Radio City Starts With 13,000 KVA Capacity, E. Clute, *Electrical World*, Vol. 99, April 9, 1932, pages 656-659.
39. Overhead Secondary Network Next Move In Distribution, W. R. Bullard, *Electrical World*, Vol. 99, April 23, 1932, pages 745-746.
40. Overhead Secondary Network Offers Real Economy, J. S. Parsons and L. M. Olmsted, *Electrical World*, Vol. 99, May 7, 1932, pages 808-813.
41. Protectors For Overhead Networks, J. A. Butts, *Electrical Journal*, Vol. 29, May, 1932, pages 245-247.
42. Spot Networks Installed In Chicago Region, C. E. Van Denburgh, *Electrical World*, Vol. 100, September 3, 1932, pages 381-382.
43. Spot Networks Reduce Cost of Duplicate Service, John S. Parsons and S. B. Griscom, *Electric Journal*, Vol. 29, November, 1932, pages 503-505 and 530.
44. New Reactors Limit Voltage Rise on Network Cables, C. A. Woodrow, *Electrical World*, Vol. 100, December 17, 1932, pages 822-824.
45. Voltage Regulation of Cables Used For Low-Voltage AC Distribution, H. R. Searing and E. R. Thomas, *A.I.E.E. Transactions*, Vol. 52, No. 1, March, 1933, pages 114-120.
46. Application of Phase Sequence Principles To Relaying of Low Voltage Secondary Networks, H. R. Searing and R. E. Powers, *A.I.E.E. Transactions*, Vol. 52, No. 2, June, 1933, pages 614-620, (discussion pages 626-629).
47. Voltage Regulation and Load Control, H. C. Forbes, and H. R. Searing, *A.I.E.E. Transactions*, Vol. 53, 1934, pages 903-909, (discussion pages 1525-1528).
48. Motor-Starting-Current Steps Based on Connected Load, Thomas J. Brosnan, *Electrical World*, Vol. 103, April 28, 1934, pages 608-609.
49. Distribution System Within Rockefeller Center, *Electric Journal*, Vol. 31, May, 1934, pages 180-183.
50. Load Division in Networks, L. M. Olmsted, *Electric Journal*, Vol. 31, June, 1934, pages 226-227 and 232.
51. Improving the Division of Load In Networks, L. M. Olmsted, *Electric Journal*, Vol. 31, July, 1934, pages 268-271.
52. Limiting Voltage Rise on Cable Fed Networks, R. E. Powers, *Electric Journal*, Vol. 32, July, 1935, pages 290-293.
53. Secondary Network Goes Overhead, R. O. Sutherland, *Electrical World*, Vol. 106, April 25, 1936, pages 1170-1172 and 1249.
54. A New Thermal Fuse For Network Protectors, L. A. Nettleton, *A.I.E.E. Transactions*, Vol. 55, October, 1936, pages 1096-1099, (discussion Vol. 56, pages 1031-1032).
55. Small Underground Networks, J. A. Pulsford, *Electric Journal*, Vol. 34, March, 1937, pages 111-114.
56. Heavy Duty Network Protector, G. G. Grissinger, *Electric Journal*, Vol. 34, June, 1937, pages 254-256.
57. New Network Relays, John S. Parsons and M. A. Bostwick, *Electric Journal*, Vol. 34, July, 1937, pages 288-293.
58. Short-Circuit Protection of Distribution Networks By the Use of Limiters, C. P. Xenis, *A.I.E.E. Transactions*, Vol. 56, September, 1937, pages 1191-1196.
59. Performance Tests on Non-Metallic Sheathed Cable For Underground Network Mains, C. W. Pickells, *E.E.I. Bulletin*, Vol. 5, September, 1937, pages 391-396.
60. Distribution Systems For Power-House Auxiliaries, F. S. Douglas and A. C. Monteith, *Electric Journal*, Vol. 34, October, 1937, pages 399-404.
61. Planning A Distribution System, J. F. Fairman, *Electric Journal*, Vol. 35, June, 1938, pages 236-239.
62. Operation of AC Low Voltage Network From Two Voltage Sources, W. B. Kenyon, *E.E.I. Bulletin*, Vol. 7, March, 1939, pages 115-118.
63. AC Network Operation, 1936-1937, *E.E.I. Publication No. C1*, August, 1938, 48 pages.
64. Operating Record Proves Value of Limiters, C. P. Xenis and E. Williams, *Electrical World*, Vol. 112, October 21, 1939, pages 1165-1166 and 1225.

65. Philadelphia AC Network Operating Results, Paul W. Crosby, *Electrical Engineering*, Vol. 58, December, 1939, pages 517-521.
66. Vaults For AC Secondary Networks, John S. Parsons, *Electrical World*, March 23, April 20, and May 18, 1940, pages 886-888, 955, 1201-1203, 1277-1278, 1512-1513, and 1572-1573.
67. Simulated Network Checks Actual System, C. T. Nicholson, *Electrical World*, Vol. 114, September 7, 1940, pages 670-671.
68. Network Protector Operations Reduced, W. W. Edson and M. A. Bostwick, *Electrical World*, Vol. 113, February 22, 1941; page 56.
69. Secondary Networks to Serve Industrial Plants, C. A. Powel and H. G. Barnett, *A.I.E.E. Transactions*, Vol. 60, 1941, pages 154-156, (discussion pages 698-700).
70. New Applications for Secondary Networks, John S. Parsons, *Westinghouse Engineer*, Vol. 1, May 1941, pages 24-27.
71. Secondary Network Planning, H. G. Barnett, *Electrical World*, Vol. 116, August 9, August 23, and September 6, 1941, pages 422-423, 425, 575-576, 579 and 718-719.
72. Secondary Network For Industrial Plants, John S. Parsons, *Westinghouse Engineer*, Vol. 1, November 1941, pages 85-88.

LAMP FLICKER ON POWER SYSTEMS

Original Author:

S. B. Griscom

Revised by:

S. B. Griscom

VOLTAGE regulation has been one of the most important problems of the electric industry since its inception. The sizes of many parts of a power system are determined largely by this one consideration alone. A large proportion of the selling price of electrical power is the interest and other fixed charges on production and distribution facilities, so that any improvement in regulation is ultimately reflected in higher rates. Similarly, types of load imposing exceptionally severe regulation requirements will also increase the cost of supplying energy.

In the early days of the industry, a relatively wide range of voltage variation was permissible, because the public was at that time unaccustomed to uniform lighting intensity. Today, there is a greater consciousness as to whether the voltage level is about right, as indicated by the "whiteness" of the light and by lamp life. While, however, a narrower voltage band is required than formerly, this is not always the limiting factor in voltage regulation. Numerous new devices have been added to power lines in the last few years, which impose rapid and frequent changes of load, with correspondingly rapid voltage changes. Repeated observations have shown that rapid changes of voltage are much more annoying than slow ones, so that "flicker" effects may limit the useful load-carrying ability of individual circuits long before maximum steady-state regulation or heating is reached.

Consequently, the voltage regulation problem must now be considered from two angles: the normal drop in voltage from light load to full load, and the superimposed flickers due to motor-starting and to various pulsating and irregular loads. The differences in voltage between light and full load affect the performance, efficiency, and life of electrical equipment, and are treated in Chap. 10. The present chapter considers only the flicker component of voltage regulation, and deals primarily with the reaction of the human eye to variations in electric light intensity.

I. PERMISSIBLE FLICKER

The permissible amount of flicker voltage cannot be stated concisely for several reasons. There is first the human element; one individual may think objectionable a flicker not perceptible to another. The lighting fixture used is of considerable importance. Smaller wattage incandescent lamps change illumination more quickly upon a change of voltage than lamps with heavier filaments. The character of the voltage change is also important. Cyclic or rapidly recurring voltage changes are generally more objectionable than non-cyclic. On non-cyclic changes the annoyance due to the flicker is affected by the rate of

change, duration of change, and frequency of occurrence of the flicker. These and other factors greatly complicate the problem of assigning limits to permissible flicker voltages.

Numerous investigators have studied the flicker problem. The most complete analysis is found in the report "The Visual Perception and Tolerance of Flicker," prepared by Utilities Coordinated Research, Inc. and printed in 1937, from which Figs. 1 to 4 of this chapter are reproduced.

Figure 1 shows the cyclic pulsation of voltage at which flicker of 115-volt tungsten-filament lamp is just perceptible

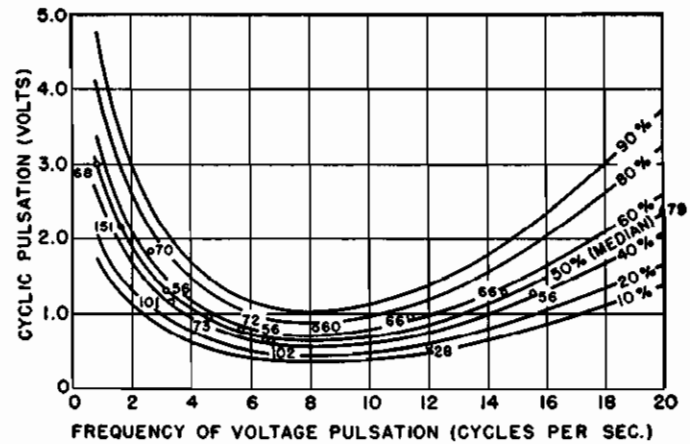

Fig. 1—Cyclic pulsation of voltage at which flicker of 115-volt tungsten filament lamp is just perceptible—derived from 1104 observations by 95 persons in field tests of 25-watt, 40-watt, and 60-watt lamps conducted by Commonwealth Edison Company. Figures on curves denote percentages of observers expected to perceive flicker when cyclic voltage pulsations of indicated values and frequencies are impressed on lighting circuits. Plotted points denote medians of observation—at various frequencies, number of observations in each case being indicated by adjacent figures.

table. Flickers as low as $\frac{1}{3}$ volt were perceptible in 10 percent of the observations, when the rate of variation was 8 cycles per second. In order for the variations to be perceptible in 90 percent of the observations, however, the voltage change had to be over one volt at the same frequency. The range between 6 and 12 cycles per second was the most critical.

Figure 2 shows the minimum abrupt voltage dip to cause perceptible flicker in a 60-watt, 120-volt tungsten-filament lamp, as a function of intensity of illumination. Curves are shown for 5 and 15 cycles (60 cycles per second basis) durations of voltage dip. It should be noted that abrupt voltage dips of 1.5 to 2.0 volts were perceptible.

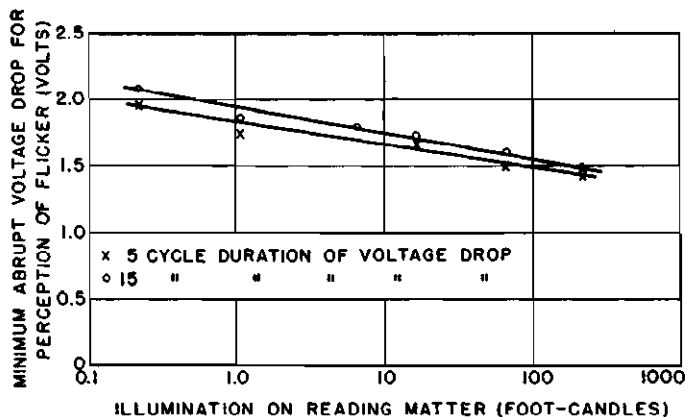

Fig. 2—Minimum abrupt voltage drop for perception of flicker of 60-watt, 120-volt coiled-coil tungsten-filament lamps operated on 60-cycle alternating current. Each point represents the means of the observation of 44 persons.

Figure 3 shows the effect of “duration of transition” of voltage on the average threshold of perceptibility of flicker for tungsten-filament lamps. This curve shows quite clearly that whereas an abrupt change of about 1½ volts

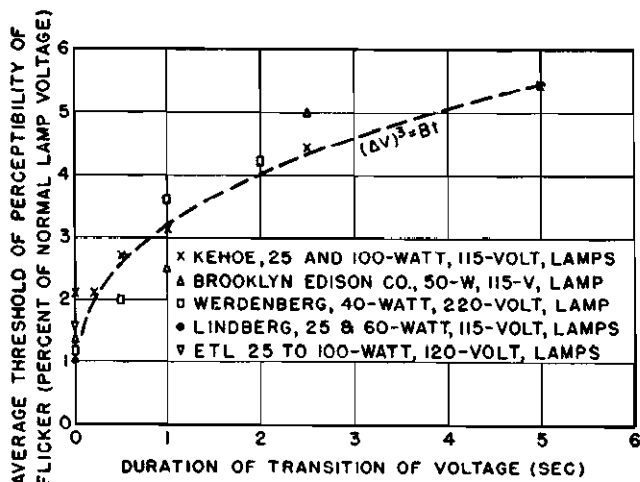

Fig. 3—Effect of duration of transition of voltage on average threshold of perceptibility of flicker of tungsten-filament lamps.

is perceptible, a change of 5 volts or more is necessary before voltage variations requiring several seconds for completion can be perceived.

Figures 1 to 3 are of interest in showing the perceptibilities for various classes of flicker voltages. These are not working limits, because a perceptible flicker is not necessarily an objectionable one. Fig. 4 shows the recommended maximum allowable cyclic variation of voltages as set up by various authorities for their own use. The variations in these recommendations is an indication of the extent to which individual judgment enters the problem. The curves are nevertheless an exceedingly valuable guide.

Cyclic flicker, when perceptible, is likely to be objectionable, at least to some individuals. Isolated voltage dips, however, even if plainly perceptible, are not objectionable to the majority of individuals unless rather frequent. It can, therefore, be expected that larger vari-

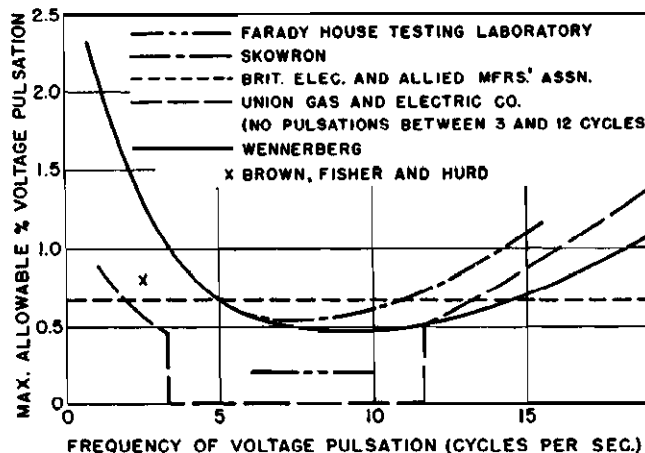

Fig. 4—Recommended maximum allowable cyclic variation of voltage.

TABLE 1—MAXIMUM ALLOWABLE VOLTAGE FLUCTUATIONS

Class of Service	Volts on 115 Volt Basis			
	Infrequent	Frequent	Very Frequent	Extremely Frequent
A. *On a substation bus feeding only power lines.....	6	4	3	3
B. *On a power line primary whose entire output is not taken by the one customer and read at the customer's premises.....	8	6	4	4
C. On a power line whose entire output is taken by one customer and read at the customer's premises	No definite Limit			
D. On a substation bus feeding distribution circuit and on distribution circuit primaries.....	6	3**	2	2
E. On a distribution circuit secondary:				
(a) At the secondary customer causing the fluctuation.....	6	6	4	3
(b) At the secondary customer not causing the fluctuation..	6	5**	3**	2

*Loop Power Lines or their equivalent automatic throwover lines shall be considered as Distribution Circuits.

**On Farm Lines this limit has been increased to six volts because motor starting is so largely confined to daylight hours. This limit permits us to reasonably cope with the long distances encountered

DEFINITIONS:

1. Infrequent Flicker shall include cases occurring six times or less in twenty-four hours but not more than once between 6:00 p.m. and 12:00 midnight. This provision is intended to cover apparatus such as motor generators, fans, pumps, etc., which normally run continuously throughout the working day.
2. Frequent Flicker shall include cases occurring not oftener than three times per hour, except that between 6:00 p.m. and 12:00 midnight they shall not occur more than once per hour. This provision is intended to cover apparatus such as machine tools, electric furnaces, etc., which are periodically started and stopped throughout the working day.
3. Very Frequent shall include cases occurring not oftener than once a minute on the average and shall include all except rapidly and regularly recurring flickers. This provision is intended to cover such apparatus as elevator motors, automatic pumps, ice machines, etc., which are started fairly frequently but, in general, are not regularly started several times a minute.
4. Extremely Frequent shall include all cases occurring more frequently than the above. This provision is intended to cover such apparatus as flashing signs, welders, gravel pit hoists, and certain electric furnaces, which are frequently and repeatedly stopped and started or rapidly loaded and unloaded during normal use.

ations are permissible for non-cyclic than for cyclic variations, but that the amount of tolerable dip depends upon

the frequency of occurrence and the class of service. Here again, judgment is an important factor as well as technical facts. The maximum allowable fluctuations practiced by one operating company are shown in Table 1.

This is a very comprehensive set of standards and has proved satisfactory in practice.

II. ORIGIN OF FLICKER VOLTAGES

Flicker voltages may originate in the power system, but most frequently in the equipment connected to it.

1. Generating Equipment

Prime Movers—Engine driven generators are probably responsible for most of the rare cases of flicker originating due to the power system itself. Curve (a) of Fig. 5 shows the variation in tangential force of a four cylinder

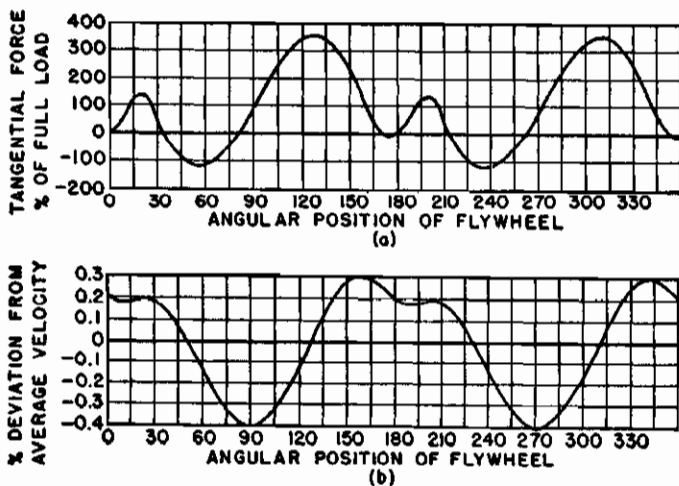

Fig. 5—Curves from a four-cylinder 300 rpm Diesel engine at full load driving a generator. The variation in velocity caused a corresponding variation in the generated voltage.

300 rpm Diesel engine at full load, and Curve (b) shows the corresponding percent change in angular velocity of the rotating parts. With all other factors constant, this non-uniform rate of rotation produces a fluctuation in amplitude of the generator voltage. The total variation in voltage is the same as the total variation in speed; in this example 0.7 percent. The frequency of the variation is equal to the rpm times the number of power strokes per revolution; in this case $300 \times 2 = 600$ per minute or 10 per second.

Referring to Fig. 1, it is seen that 0.7 percent change in voltage is readily perceived by most individuals. Fig. 4 indicates that most operators regard this as too much flicker to be tolerable. About the only practicable remedies are increasing the flywheel effect, or changing the speed to get within a less objectionable frequency range. In this actual case, the flicker of the original installation caused many complaints and it was satisfactorily corrected by increasing the flywheel effect.

When two or more engine-driven generators are in continuous operation at the same station, the amplitude of the fluctuation can frequently be lowered, and the fre-

quency doubled to get it out of the objectionable range, by synchronizing the generators so that the power strokes of the two engines alternate rather than occur simultaneously. This can be done because there are usually more poles on the generators than cylinders on the engine, particularly in those engines where the flicker is in the objectionable range. A stroboscope or similar device used with the regular synchroscope permits such synchronizing.

It has sometimes been thought that it should be possible to correct flicker of this type by the use of special voltage regulators of unusually fast response. In practically every case this is completely out of the question because the frequency of the flicker is too high for the time constant of the generator field. For example, the field time constant of a typical moderate-sized engine-type generator is between 0.5 and 1.5 seconds, whereas the range of most objectionable flicker is between $\frac{1}{4}$ and $\frac{1}{8}$ second per cycle. Even electronic excitation systems are unable to regulate voltage at such a high rate.

Generators—A symmetrical generator with constant load, excitation and angular velocity produces a constant terminal voltage. If any of these quantities varies, however, the terminal voltage also varies.

It is possible to have a sufficient degree of non-uniformity in the generator air gap to cause pulsating terminal voltage. However, the commercial manufacturing tolerances are sufficiently close that no case of flicker due to this cause is known to have occurred. To produce flicker in this manner, both the rotor and stator must be eccentric. Stator bores of all but the smallest size machines will inherently have a certain degree of eccentricity, because they must be built up with segmental laminations. In spite of this built-up construction, quite close tolerances are held by the use of accurate dies and assembly keys and dowels. Further attempts at improvement would be very difficult as it would require boring or grinding the inner bore of the stator punchings. This is quite undesirable from the standpoint of accumulation of iron chippings and filings between laminations and into the slots, which might result in a condition of insulation breakdown and localized heating of the stator. The rotor eccentricity is, because of the necessity of dynamic balancing, held normally to quite close tolerances. Since no voltage fluctuations can be produced if the rotor is concentric with the shaft, no modification of standard manufacturing procedures has ever been necessary from the standpoint of flicker voltages.

Abrupt changes of load on generators produce corresponding changes in the terminal voltages. This voltage fluctuation is the result of two factors: the change in speed, and the regulation of the machine. In central station practice it is very unusual for change in speed to be a significant factor. Sudden load increments are usually too small as compared with the total generating capacity to change the speed materially. Even if the speed changes, however, the rate at which the voltage drops is ordinarily so slow, that the effect is imperceptible to the eye (see Fig. 3).

A typical voltage-time regulation curve of a large turbine generator, following sudden application of load is shown in Fig. 6. Speed and excitation voltage are assumed constant. Three points on this curve are of especial in-

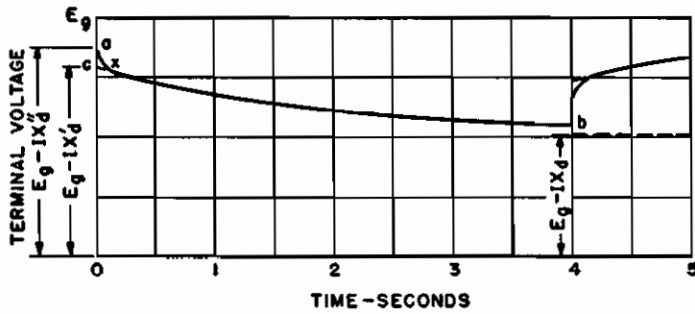

Fig. 6—Voltage-time regulation of a large turbo-generator following sudden application of load.

terest. Point (a) is the voltage immediately following the application of load; point (b) is the voltage after the voltage has settled; point (c) is an extrapolation of the curve from (b) back to zero time. Each of these points may be determined closely by the use of the appropriate generator reactance. In fact, the standard definition of the various reactances has been made for this particular use. For a fuller discussion of machine characteristics see Chap. 6.

Point (a) is determined by the use of the machine subtransient reactance x_d'' . In the case of an initially unloaded machine, the voltage (0-a) is the vector difference between the no-load voltage and the product of the load current times the subtransient reactance. That is,

$$0-a = E_g - Ix_d''$$

The voltage rapidly falls further to a point (x) and at a much lower rate to point (b).

The reason may be described approximately as follows. At the instant of load application, the magnetic flux in the air gap remains substantially constant, and the initial drop in voltage is principally that due to reactance of the armature winding. However, the armature currents set up a demagnetizing effect to buck the field flux. The decreasing field flux generates voltages and currents in the field structure, which resist or delay the ultimate change. The induced currents in some parts of the field structure, such as the eddy currents in the pole face, damper windings, or rivets, subside rapidly because of the high resistance of the path, and allow part of the flux to change quickly. In the average machine, about 0.1 second is required for this change. Most of the change of voltage between points (a) and (x) is due to this cause. The majority of the field flux is encircled by the field winding which is of very low resistance, and, therefore, constitutes an effective damper to rapid changes of voltage. The change in voltage from (x) to (b), therefore, constitutes an effective damper to rapid changes of voltage. The change in voltage from (x) to (b) is, therefore, comparatively slow, from 3 to 10 seconds being required for 90 percent of the change to take place in large machines.

Point (x) is not directly calculable by using standard machine reactances alone. Point (c), however, can be calculated in the same manner as point (a), except that transient reactance is used. That is

$$0-c = E_g - Ix_d'$$

Similarly, point (b) is calculated from synchronous reactance using the relation:

$$0-b = E_g - Ix_d$$

The transition from (a) to (x) and from (x) to (b) may be calculated by using the appropriate machine time constants. This procedure is more fully described in Chap. 6. From the standpoint of flicker voltage, the following points are of interest.

For single load applications more than 10 cycles in duration (on a 60-cycle system), the voltage regulation point (c) of Fig. 6, calculated from the transient reactance, is the determining quantity. Fig. 2 shows that there is little difference in perception lasting from 5 to 15 cycles of voltage drop. In average machines, the subtransient drop is usually about two-thirds of the transient drop. However, after about the first 5 cycles, the voltage drops to the value determined by transient reactance. A further drop in voltage takes place due to the decrement of the field, reaching point (b) on Fig. 6. Usually, this synchronous reactance drop is not more than two or three times the transient reactance drop. Automatic voltage regulators may limit the drop to less than $1\frac{1}{2}$ times the transient drop. Reference to Fig. 3 shows that for a transition time of the order required (3 to 10 seconds), the additional voltage drop due to field decrement is not perceptible.

For load durations less than 5 cycles, it is likely that the regulation as calculated from the subtransient reactance determines the permissible flicker. While the voltage drop at the end of 5 cycles is greater than initially, the transition is gradual and it is doubtful if the eye can discern so small a difference.

For load durations between 5 and 10 cycles, it is probable that an average between subtransient and transient reactances should be used to calculate flicker voltages for comparison with perception data similar to those given in Figs. 1 to 3.

The proper reactance to be used to calculate the effect of cyclic variations depends upon the frequency of their occurrence. The following range is suggested for generators 5000 kva and above.

Pulsation Frequency Cycles per Second	Reactance
1-4	x_d'
5-12	$\frac{x_d' + x_d''}{2}$
12-30	x_d''

In smaller machines the field time constant may be so short that pulsation frequencies below 2 cycles per second may require the use of synchronous reactance.

Excitation Systems—Excitation systems are rarely the cause of flicker voltages in central station practice. In larger generators, field time constants above 3 seconds cause variation in armature voltage to be very gradual no matter how fast the excitation may change. Occasionally, hunting of generator voltage regulators causes wide voltage fluctuations, but this is not a true flicker. On small generators, continuously vibrating regulators occasionally cause a small pulsation of the armature voltage.

Since the alternator field constant is usually too high to permit exciter fluctuations to show up in the alternator terminal voltage, correction of flicker by means of excitation control is not practical. In other words, the amount of generator flicker depends upon its inherent reactance characteristics and cannot be substantially improved by excitation control.

Short Circuits and Switching Surges—Short circuit currents, because of their magnitude, produce large voltage drops and attendant flicker. Reduction in the amount of voltage drop is not feasible without major changes in system layout and large expenditures. The duration of the voltage drop can, however, be markedly reduced in a number of cases by the use of high-speed relays and breakers. Flicker due to short circuits occurs so seldom that no special consideration for this purpose alone is necessary. The tendency is toward a gradual reduction in flicker, as system improvements are made for other purposes such as protection of lines against lightning, installation of high speed relays and breakers, etc. These comments apply to networked systems; in radial lines, short circuits produce outages, a distinctly different problem.

Line switching rarely produces flicker unless load is picked up or dropped, or lines with large charging currents are switched. Here again, special provisions to reduce flicker are rarely necessary.

2. Utilization Equipment

Most of the flicker on central station systems is due to the customer's utilization equipment. The following are some of the more common types of equipment known to cause flicker.

Motor Starting—Probably most of the flicker problems are caused by the starting of motors. For reasons of cost, efficiency, and reliability, commercial general purpose motors require a momentary starting current several times their full load running current, in order to produce sufficient starting torque.

Three general classes of motor installations are of importance in the flicker problem.

- (1) Single phase fractional horsepower motors commonly used in homes and small stores.
 - (2) Integral-horsepower polyphase motors operated from secondary distribution circuits, such as in small shops, large stores and buildings, and recently in a small number of homes for air conditioning.
 - (3) Large integral-horsepower three-phase motors operated from primary lines, mostly by industrial concerns.
- (1) Single phase fractional horsepower motors are manufactured in large quantities, and to maintain this extent of usage, they must continue to be low in cost, economical, rugged and reliable. These requirements have led to several classes of motors depending upon the service, with one class designed specifically for frequent starting with low starting current. This motor is used in great quantities in domestic refrigerators and oil burners, and the $\frac{1}{4}$ horsepower 110-volt class usually has a locked-rotor starting current of 20 amperes or less. It is not unduly expensive

to design a distribution system to supply 20 amperes at 110 volts without objectionable lamp flicker. Where single phase 110/220 systems are used, 40-ampere starting currents are permissible on the 220-volt connection, allowing larger motors to be used.

(2) Integral-horsepower motors on secondary circuits are potential sources of flicker. In most cases, such motors are used in areas of high load concentration and the power circuits are correspondingly large. This usually permits ordinary 3-phase squirrel cage motors to be started directly across the lines. In some cases, however, the size of a motor is out of proportion with its supply line. The practical solution is to use a starter that limits the initial inrush of current and thereafter changes the current in increments sufficiently small to prevent objectionable lamp flicker.

(3) Supplying large motors from primary power lines is usually not troublesome because such motors are usually located in an "industrial district" where power supply lines are inherently heavy and where wider limits of voltage drop are permissible (See Table 1). There are nevertheless a number of cases particularly in rural communities, where motor ratings are too high for the power facilities. A suitable motor starter may correct such cases, although in some installations other measures may be required.

Starting currents for both induction and synchronous motors at full voltage vary from 5 to 10 times full load, depending upon the size, number of poles, and other application requirements, such as required starting, pull-in, and pull-out torques. The power factor under locked-rotor conditions varies between 25 and 50 percent. For approximate calculations, a starting current of 6 times normal at 35 percent power factor may be used. Wide variations from this should be expected, and specific data should always be used when obtainable.

Motor-Driven Reciprocating Loads—This type of load usually consists of air compressors, pumps and refrigerators. The motor load varies cyclically with each power stroke and produces a corresponding variation in the line current. Thus, comparatively small variations of voltage may be objectionable if the pulsation occurs 6 to 12 times per second. (See Fig. 1.) Difficulty from this source has been caused in the past by domestic refrigerators, but in modern designs both the frequency of pulsation and the amount of fluctuation have been improved, so that complaints from this cause are now rare.

Figure 7 is an oscillogram showing the armature voltage, current and three-phase power of an air compressor driven by a 100-horsepower wound rotor induction motor. There are several points of interest on this oscillogram. First, although the voltage variation can scarcely be detected on the oscillogram, it actually was very objectionable to lighting customers. This shows that oscillographs used in the conventional manner may not always be suitable for flicker-voltage measurements. Second, the three-phase power and current fluctuations occur simultaneously and the peak is about $2\frac{1}{2}$ times the minimum. This is interesting because it shows that the slip of induction type motors cannot prevent load fluctuations from showing up in the supply lines, unless the inertia of the load is high or the rate of power pulsation is high.

Publication C 50-1943 "American Standard Rotating Electrical Machinery" of the American Standards Committee establishes the amount of pulsations for synchronous motors. Section 3-160 reads:

"Pulsating Armature Current: When the driven load such as that of reciprocating type pumps, compressors, etc., requires a variable torque during each revolution, the combined installation shall have sufficient inertia in its rotating parts to limit the variations in motor armature current to a value not exceeding 66 percent of full load current.

"NOTE I—The basis of determining this variation shall be by oscillograph measurement and not by ammeter readings. A line shall be drawn on the oscillogram through the consecutive peaks of the current wave. This line is the envelope of the current wave. The variation is the difference between the maximum and minimum ordinates of this envelope. This variation shall not exceed 66 per cent of the maximum value of the rated full load current of the motor. (The maximum value of the motor armature current to be assumed as 1.41 times the rated full load current.) Adopted Standard 6-13-1923."

The above excerpt provides a basis for standardization and gives a criterion for a design unlikely to cause flicker. However, there are still possibilities that this amount of pulsation may at times result in flicker, particularly if the rate is between 6 and 12 cycles per second, and the supply line impedance is high.

An analysis of Fig. 7 shows that with an induction motor both the current and power factor pulsate when the motor load varies, the power factor being highest when the load is highest as shown in the tabulation below. Usually, the armature time constant is high compared with the rate

of load fluctuation, and the steady-state performance of moderately-sized induction motors as determined by test or circle diagram may be used in calculating flicker due to cyclic load variation of power factor with load, but specific data should be used where obtainable.

Load, Percent	Power Factor, Percent
25	72
50	78
75	85
100	87
125	90

The variation of power factor of a synchronous motor during cyclic load fluctuations is a more complicated phenomenon. The average power factor is, of course, greatly influenced by the supply voltage and by the field excitation. The variations from this average power factor due to load fluctuation is largely dependent upon the rate of the fluctuations as compared with the time constant of the field. For example, if the field time constant is 1 second and the load fluctuates once every 2 seconds the synchronous reactance of the machine determines the extent of the change in power factor. If, however, the power fluctuations are, say, 8 cycles per second, the transient reactance largely determines the change in power factor because the load swings are too rapid to demagnetize the field.

Since in flicker problems, the *change* in load is of greater concern than the *magnitude* of the load, the average power factor is of no particular interest. The preferable proce-

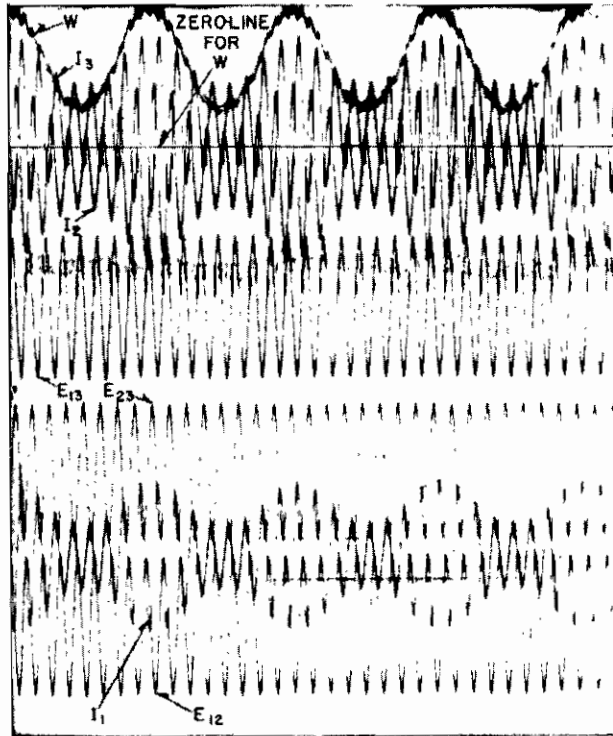

Fig. 7—Oscillogram of current I , voltage E , and three phase power W of a 100-hp wound-rotor induction motor driving an air compressor. The voltage change which cannot be measured from the oscillogram caused objectionable flicker.

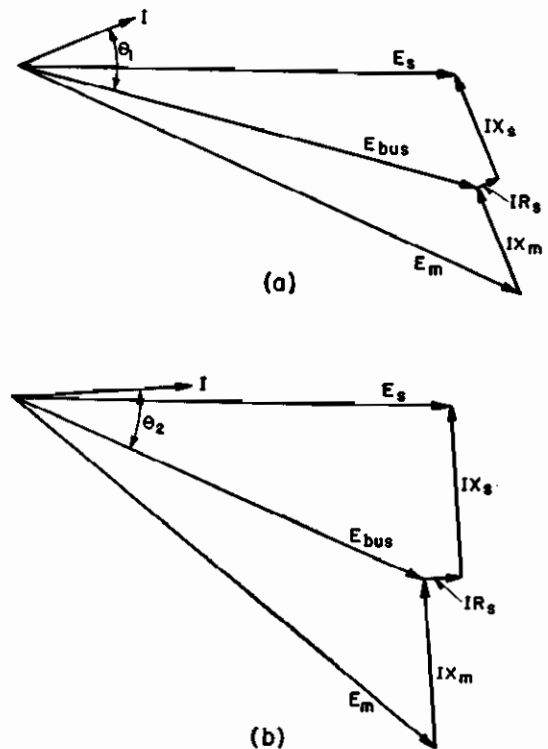

Fig. 8—Vector diagrams illustrating method of obtaining magnitude and phase position of synchronous motor current and magnitude of bus voltage with change of load. X_s is system reactance and X_m is motor reactance.

ture, if complete motor data are available, is to calculate the changes in the bus supply voltage to the motor due to changes in the load on the motor. The method is illustrated in the vector diagrams on Fig. 8. Vector diagram (a) shows the vector relations for a synchronous motor operating at full load and 80 percent power factor lead. E_s , E_{bus} and E_m are respectively the system voltage, bus supply voltage to the motor and the internal voltage of the motor. IR_s and IX_s are the voltage drops through the system impedance. IX_m is the drop through the motor where X_m may be the synchronous, transient or sub-transient reactance depending upon the rate of load fluctuation compared to the time constant of the machine. Using diagram (a) as the starting point where the motor power factor angle θ_1 is known along with the average load, E_{bus} and all of the reactances, the change in bus voltage can be obtained as shown in vector diagram (b). For all sudden changes in load the system voltage, E_s , and the internal voltage of the motor, E_m , remain substantially constant. To determine the sudden dip in bus voltage it is necessary to calculate a curve of bus voltage against motor load or motor load change. This requires for each point on the curve that a magnitude of current be assumed and the voltage drop through the system and motor determined. This will locate the internal voltage E_m with respect to the system voltage E_s . (In Fig. 8 E_m and also E_s in the diagrams (a) and (b) have the same magnitude).

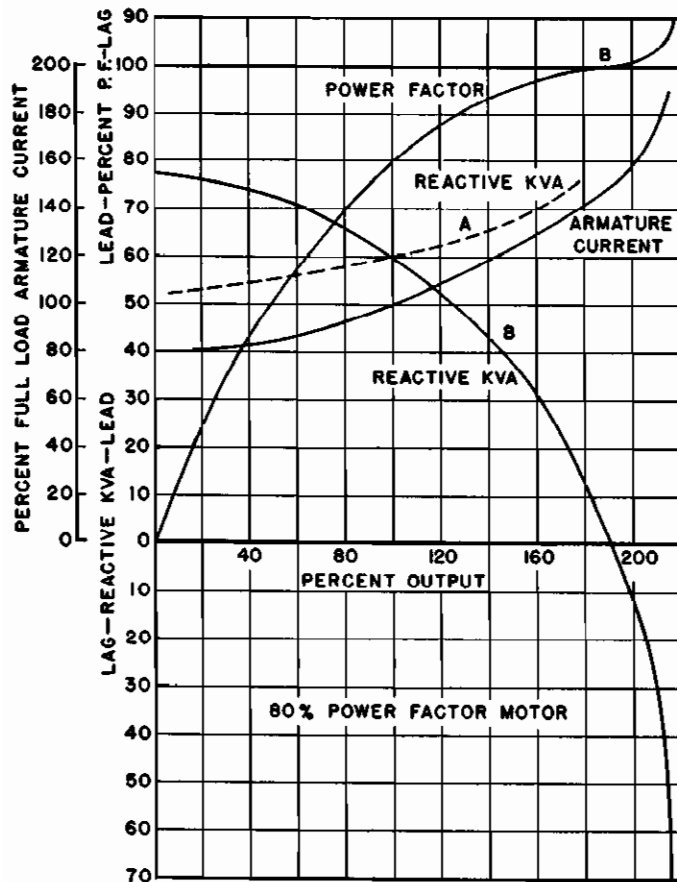

Fig. 9—Characteristics of a typical synchronous motor at normal rated voltage. Curve A is for rapid changes in load from initial value and curve B is for slow changes.

The position of the voltage drops will then determine the position of the current vector as well as the bus voltage vector E_{bus} . Using the current, voltage (E_{bus}) and the angle between them the power can be found. With the curve of bus voltage against motor load change the voltage for any desired change in motor load can be obtained.

The variation in reactive kva with real power is shown in Fig. 9 for a typical synchronous motor. These data are

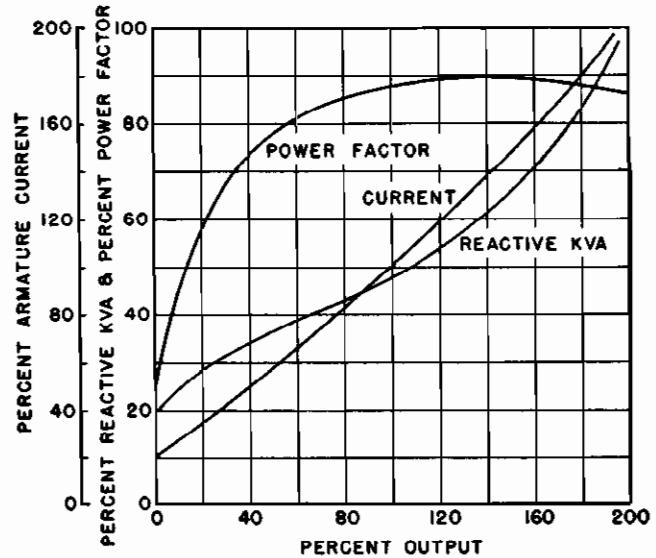

Fig. 10—Characteristics of a typical induction motor.

for a power factor of 80 percent at full load, but for ordinary purposes the variations in reactive factor may be superimposed on the initial reactive factor. Curve A is for a rapid rate of fluctuation starting from full load 80 percent power factor; Curves B are for a rate slow compared to the field time constant with fixed terminal voltage.

Motor Driven Intermittent Loads—In this category fall motor drives where the nature of the work calls for heavy overloads, and for cyclic loads of long and irregular period. Saw mills and coal cutters are typical examples of applications where heavy overloads, sometimes to the stalling point, are common and difficult to prevent. The motor currents in such installations vary rapidly from light load, through pull-out at heavy current and high power factor, to the high locked-rotor current at low power factor. Punch presses and shears are examples of applications where the load goes through wide variations, but where flywheels and other design features limit both the rate of application and magnitude of the load swings.

Motors used to drive intermittent loads are likely to have been designed with special characteristics. If possible, the fluctuation in current and power factor should be obtained by test or from the manufacturer. In the absence of such specific data, Curve B of Fig. 9 may be used for slow cycling intermittent loads, and the curve of Fig. 10 may be used for applications where pull-out and stalling occur.

Electric Furnaces—There are three general types of electric furnaces—resistance, induction, and arc. The resistance furnace usually causes no more flicker than any other resistance load of comparable size. Most induction

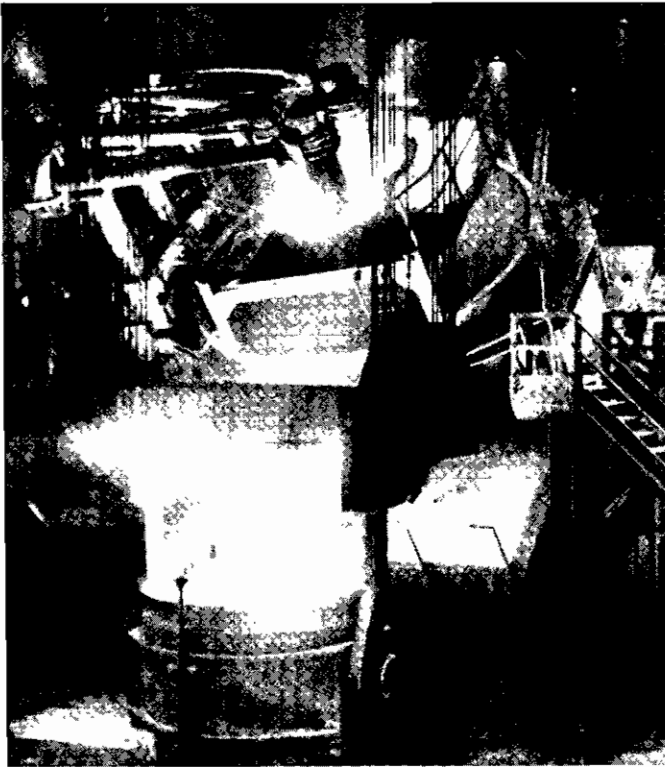

Fig. 11—Three-phase melting arc furnace of the Heroult type.

furnaces operate at high frequency, and therefore, are connected to the power line through a frequency changer and consequently represent a fairly steady load.

Three-phase steel melting arc furnaces of the Heroult type, illustrated in Fig. 11, are being used to a considerable extent to make high grade alloy steel, and frequently cause voltage flicker.

While the average load factor and power factor of electric arc furnaces are as good or better than many other industrial devices, the problem of supplying them with power is usually much more difficult. During the melting down period, pieces of steel scrap will at times, more or less, completely bridge the electrodes, approximating a short circuit on the secondary side of the furnace transformer. Consequently, the melting down period is characterized by violent fluctuations of current at low power factors, single-phase. When the refining period is reached, the steel has been melted down to a pool and arc lengths can be maintained uniform by automatic electrode regulators, so that stable arcs can be held on all three electrodes. The refining period is, therefore, characterized by a steady three-phase load of high power factor.

The size of load fluctuations during the melting down period is influenced by a number of factors, of which the rate of melting is perhaps the most important. The furnace-supply transformers have winding taps for control of the arc voltage and in the smaller sizes (about 6000 kva and below) have separate built-in reactors to limit the current and stabilize the arc. The rate of melting is subject to further control by means of electrode regulators. Sometimes the production of the furnaces is stepped up by raising the arc voltage, reducing the series reactance, rais-

ing the regulator settings or by a combination of several of these procedures. Forcing the furnace in this manner increases both the magnitude and the violence of the load swings. The type of the scrap being melted also affects the extent of the load swings, heavy scrap causing wider fluctuations than light scrap.

The oscillogram of Fig. 12 represents a short part of a melting-down period of a 10 000-kva arc furnace. At times,

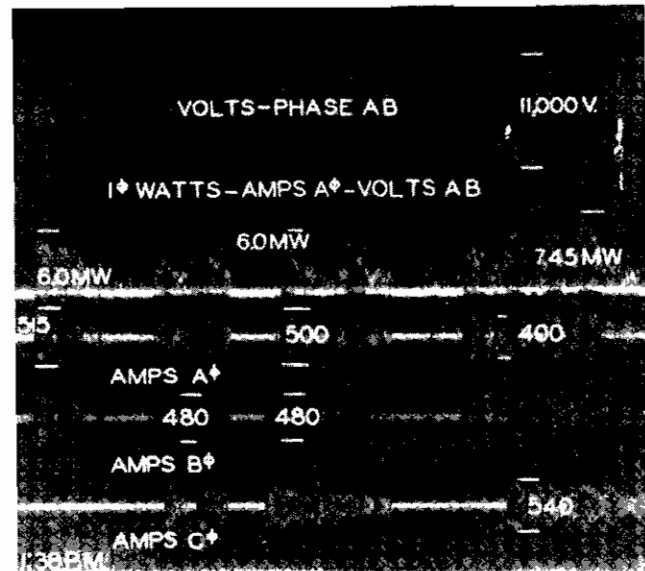

Fig. 12—Oscillogram at start of heat in a 10 000 kva Heroult type three-phase arc furnace. A single-phase arc struck and restruct 10 times in the space of 15 seconds before all three phases struck. After this initial period, all three phases struck and restruct 10 times with currents in all three phases fairly well balanced before the arcs became generally stable. A portion of this performance is shown on this figure¹⁰.

the current variations occur at a periodicity approximating the rate of the most objectionable flicker. A graphic chart illustrating the variation of load over a longer period of operation is shown in Fig. 13. These two figures are reprints of figures from reference 10.

Calculated curves in Fig. 14 show the electrical characteristics of a 10 000-kva, three-phase arc furnace. These curves were prepared on the assumption that the maximum attainable current would be approximately twice normal at 50 percent power factor. The effective impedance of the arc (based on 11 500 volts in the primary) is plotted as the abscissa. For convenience, zero ohms, as plotted, represents the minimum arc resistance as determined by the so-called short circuit condition. Actually, at this point there is appreciable voltage drop at the electrode tips, and considerable arc energy; the curves are plotted in this manner only to show the working range. It is of interest that the point of maximum power is not that of maximum kva. The usual melt-down range is probably between the points corresponding to 0 and 10 ohms, the arcs fluctuating during this period so that the heating effect is some sort of an average between these limits. The refining range is probably above 10 ohms.

It is difficult to obtain definite figures on the values of instantaneous swings in current and power factor for use

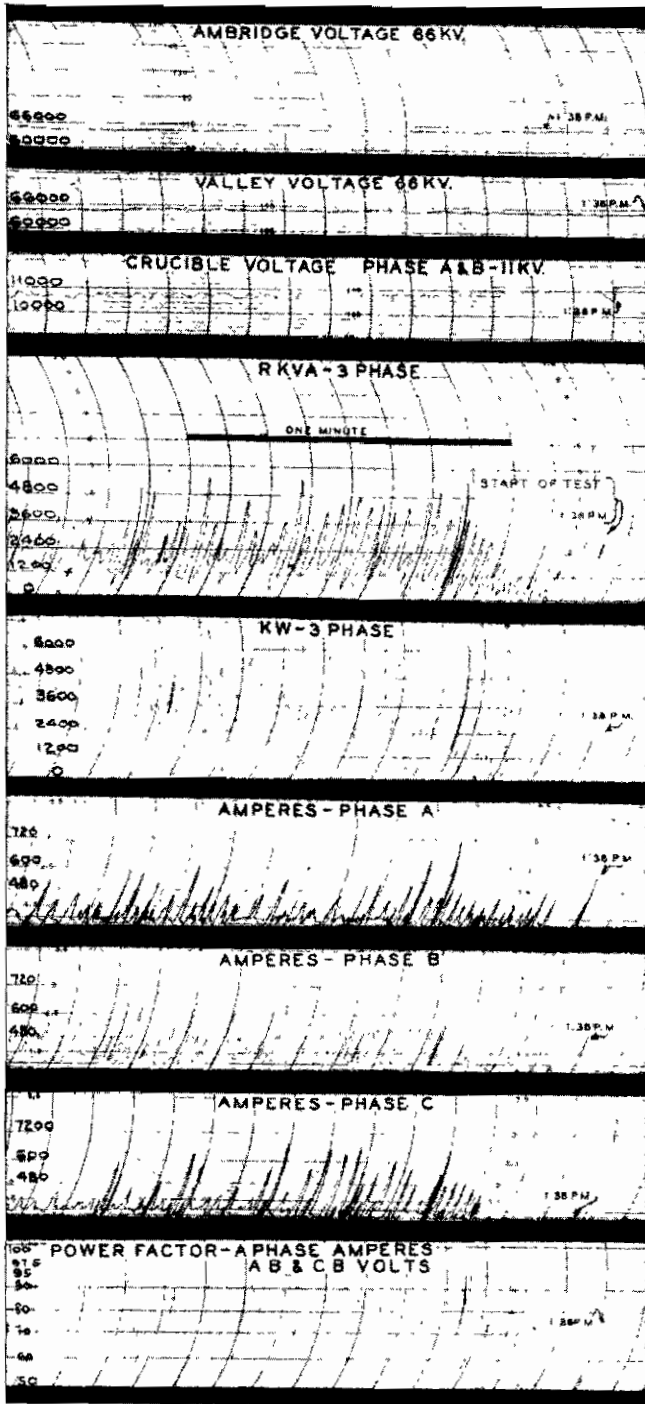

Fig. 13—Graphic charts at time of same heat shown on oscillogram of Fig. 12. Furnace swings occur approximately once a second¹⁰.

in flicker determinations, because an oscillograph must be used and the maximum swings cannot always be caught. On small furnaces, the current may reach a maximum of $3\frac{1}{2}$ times that at full load, but the process of reaching this value is usually through a series of small increments, and as noted previously the annoyance to lighting customers is largely a matter of the rate of change rather than the total change.

The kva swings given in Figure 15 are equivalent swings.

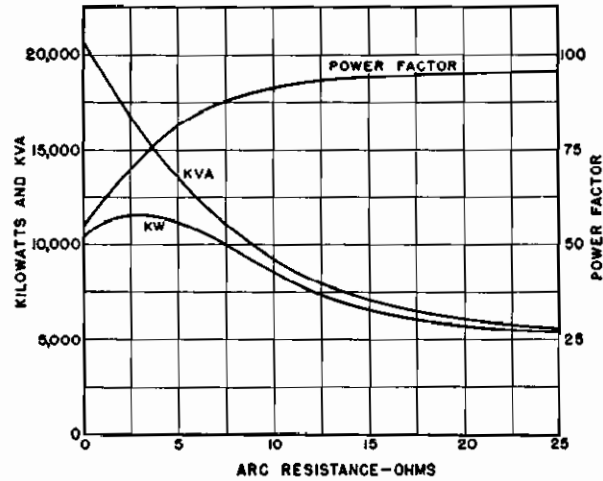

Fig. 14—Electrical characteristics of a 10 000 kva, three-phase arc furnace.

These values will give approximately the same flicker as the single-phase swings given in references 14 and 15. The curve values are not the maximum possible swings for a given furnace size but are good values to use in estimating flicker. The frequency of occurrence of these swings corresponds to the Extremely Frequent classification as given

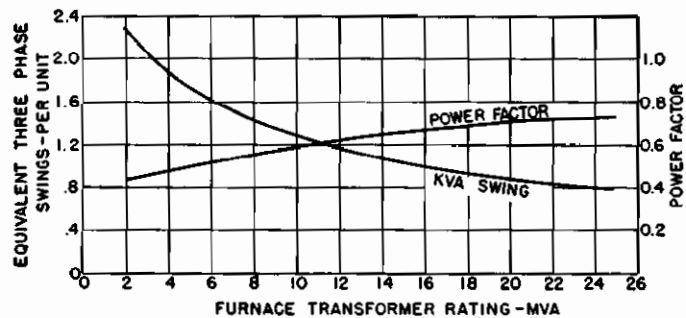

Fig. 15 Equivalent kva swings in an electric arc furnace.

in Table 1. Load swings can occur more rapidly, but their magnitudes are less than those in Fig. 15. These curves can be used in conjunction with the method suggested in Sec. 5, to estimate the amount of flicker. The information shown in Fig. 15, together with suitable system constants should give a fair approximation of the flicker voltage to be expected.

Electric Welders—This is a class of equipment of great importance in power system flicker. Most welders have a smaller “on” time than “off” time, and consequently, the total energy consumed is small compared with the instantaneous demand. Fortunately, most welders are located in factories, where other processes require a large amount of power, and where the supply facilities are sufficiently heavy, so that no flicker trouble is experienced. In isolated cases, but nonetheless important, the welder may be the major load in the area, and serious flicker may be imposed on distribution systems adequate for ordinary loads.

The more common types of electric welders are:

- (1) Flash welders
- (2) Pressure butt welders
- (3) Projection welders
- (4) Resistance welders
 - (a) Spot
 - (b) Seam

In welders the source voltage, usually 230, 460 or 2300 volts is stepped down to a few volts to send high current through the parts to be welded. Practically all welders in service are single-phase, although experimental three-phase welders show promise.

With flash welders, one piece is held rigidly, and the other is held in quasi-contact with it, with voltage applied. An arc is formed, heating the metal to incandescence, and the movable piece is made to follow to maintain the arc. The heating of the metal is partly by the passage of current and partly by burning with the arc. After a sufficient temperature and heat penetration has been obtained, the pieces are forced together under great pressure. In some cases, the power is cut off before this "upset"; in others, the power is left on. The current, drawn during the flashing period, is irregular because of the instability of the arc, so that the flicker effect is obnoxious more than if the current were steady at its maximum value. The average power factor during flashing may be as high as 60 percent. At upset, it is about 40 percent. The flashing may last up to 20 or 30 seconds, but 10 seconds is more common. The duration of power during upset is usually short; of the order of $\frac{1}{2}$ second. This type of welder may draw up to 1000 kva during flashing and about twice this loading at upset.

Pressure butt welders are similar to flash welders, except for the important difference that the parts being welded are kept continuously in contact by a following pressure. The heating is produced primarily by contact resistance. From a power supply standpoint the butt welder is more desirable than the flash welder because the welding current once applied, is practically steady and the only flicker produced is at the time power is applied and removed. The range of currents and power factors is about that for flash welders.

Projection welders are similar to pressure butt welders except that the latter usually join pieces of about equal size, and projection welders usually join small pieces to large ones. The current demand is usually smaller, but the operations are likely to be more frequent.

In resistance welders current is applied through electrodes to the parts to be welded, usually thin sheets of steel or aluminum. The weld is accurately timed to bring the metal just to the welding temperature. The pieces are fused together in a small spot. In the spot welder, one or a few such spots completes the weld. In a seam welder, a long succession of spots produces the equivalent of a single continuous weld or seam. Resistance welders are characterized by large short-time currents. In spot welders, the current may be applied for only a few cycles (on a 60-cycle basis), with welds following one another in a fraction of a second up to about a minute. Thus, from a flicker standpoint there are a succession of individual volt-

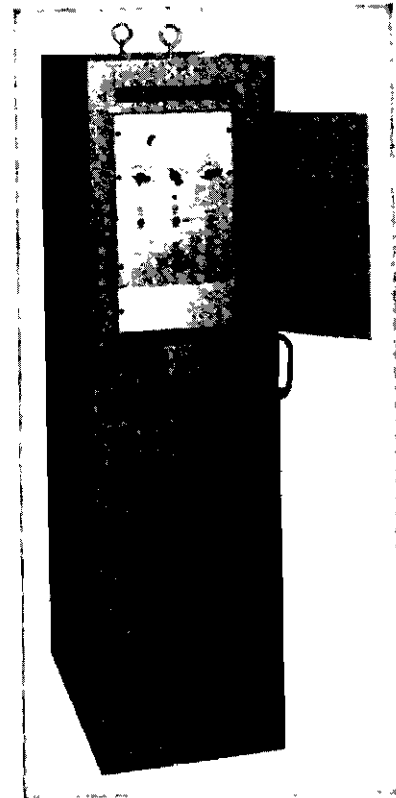

(a)

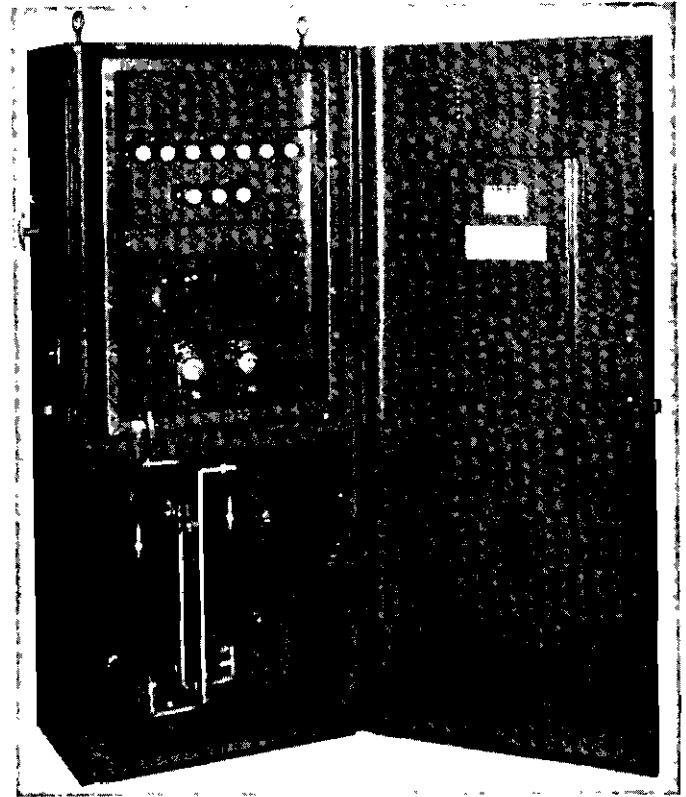

(b)

Fig. 16—Ignitron timer for resistance welder.

age dips occurring at objectionably frequent intervals. Seam welders have an "on" duration of a few cycles followed by an "off" duration also of only a few cycles. The

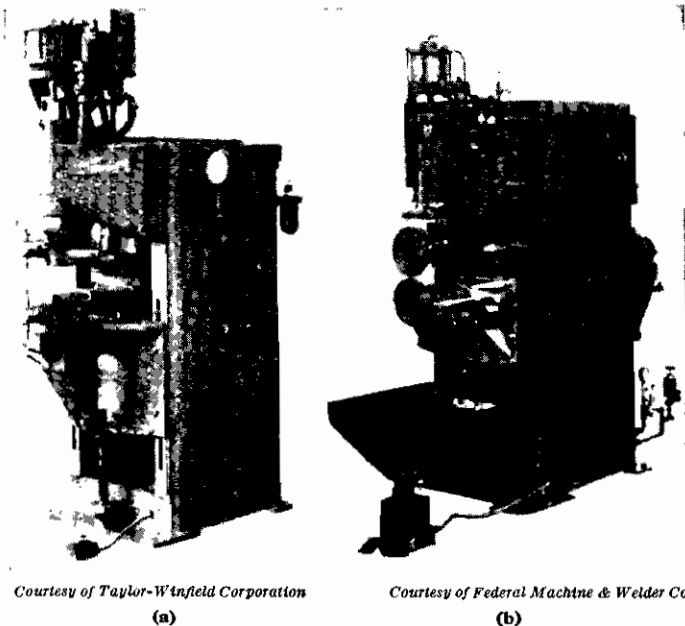

Courtesy of Taylor-Winfield Corporation

Courtesy of Federal Machine & Welder Co.

(a)

(b)

Fig. 17—Typical resistance welders—(a) spot welder, (b) seam welder.

process is a continuous one while a given piece is in the machine, and since the periodicity of the welds is uniform, the flicker can be annoying even for relatively small voltage dips. The essence of good spot and seam welding is accurate control of the heat, consequently accurate magnitude and duration of current are necessary. Vacuum tubes are being used to a large extent for welder control functions because there are no wearing parts, and close and consistent regulation of the heat is possible. Fig. 16 shows a photograph of an ignitron electric timer and Fig. 17 shows a typical resistance welder.

Resistance welders drawing energy from all three phases greatly minimize flicker. Electronic devices are used to convert from the 60-cycle, 3-phase source to a single-phase output of lower frequency, say 10 cycles per second. On small welders, the stored energy of capacitors or inductors can often be used to minimize the peak demand from the source.

Miscellaneous—Under this category come special equipment as electric shovels, heavy rolling mills, and similar installations. Most of these must be considered individually as to special features and power supply.

Strip mining shovels frequently cause severe voltage dips in power systems, principally because of their large size and wide variation of their loads. The fast rate of load application is usually injurious to the power system principally by creating a wide band of voltage fluctuation, rather than flicker as it is commonly encountered. The site of mining operation is often at out-of-the-way locations where the power requirements for general purposes are small and hence, the normal power facilities are of low capacity, and very susceptible to flicker due to load changes.

The large continuous rolling mills now used extensively in producing wide metal strip have imposed a new problem on the power industry. Like the electric shovel, these loads do not necessarily produce flicker in the customary sense of the word. The power supply is usually through motor-generator sets without added flywheel effect. The load comes on and drops off in steps as the metal enters or leaves the rolls. The individual increments are not in themselves abrupt, a fraction of a second to over a second being required for the metal to enter a roll completely. A large hot strip mill and a typical load chart are shown in Figs. 18 and 19.

The power drawn by a large continuous mill may build up to 30 000 kw in a period of 8 seconds, stay nearly con-

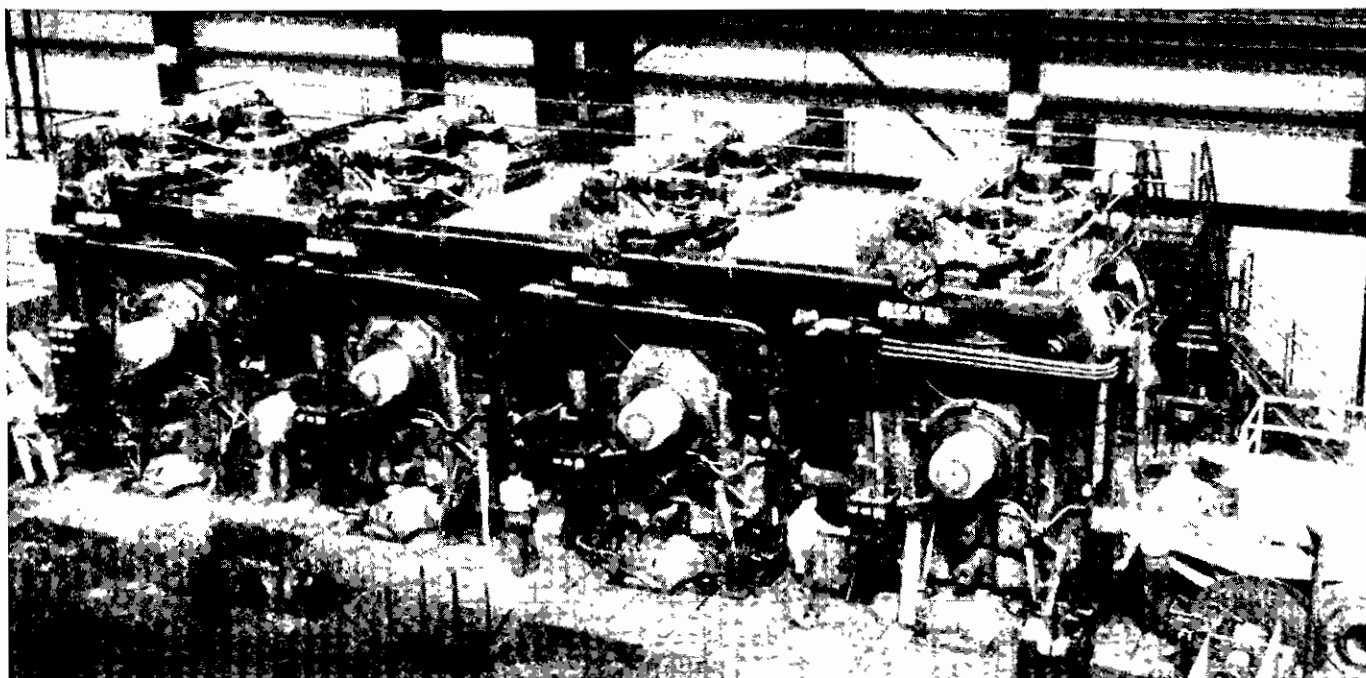

Fig. 18—Tandem cold mill for producing tinplate.

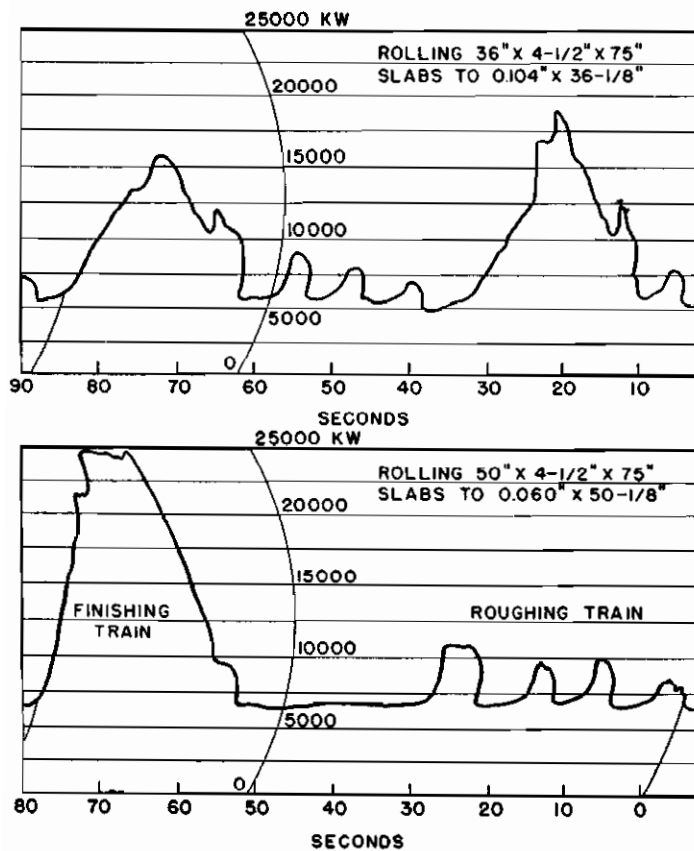

Fig. 19—Load chart for a hot strip rolling mill.

stant for a minute, and then drop to almost zero in another 8-second period. There may then be an off period of a minute followed by a repetition of the load cycle. The power source is usually ample so that no flicker is perceptible to the eye, but there is nevertheless a tendency for the voltage to "weave" up and down. This is undesirable because it widens the band of voltage regulation and may cause excessive operation of feeder voltage regulators. Automatic control of the excitation to the motor-generator sets to conform to the load variations is effective in minimizing these voltage swings.

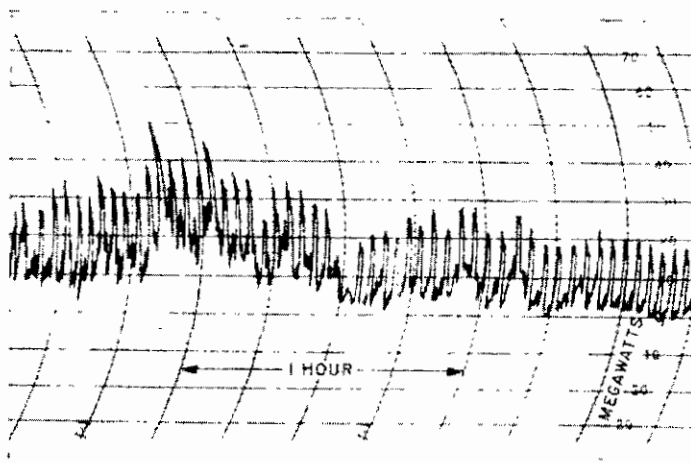

Fig. 20—Power flow between a steel mill and a large interconnected power system.

A heavy cycling load of this kind may produce wide frequency variations on an isolated power supply system and wide load swings on an interconnected system. A power plant recording chart in Fig. 20 shows the power flow between the steel mill power plant and a large power pool. Fig. 21 (a) shows the hot strip mill load cycle and

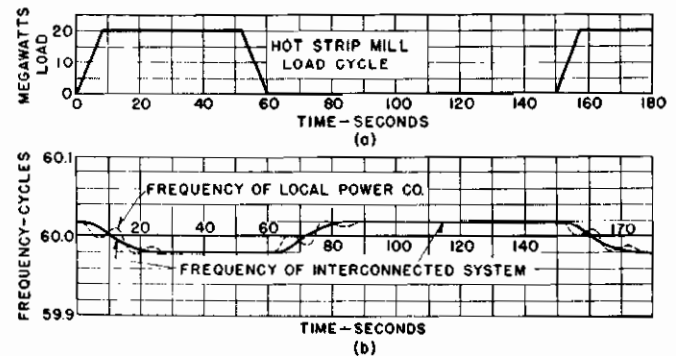

Fig. 21—(a) Hot strip mill load. (b) Effect on frequency of large interconnected system.

Fig. 21 (b) the results of calculations on how power surges of this kind cause frequency disturbances which travel as waves between the local power company to which the steel plant is connected and a larger power pool.

III. LOCATION OF FLICKER VOLTAGES

Load equipment may create flicker conditions in one or more of the following locations:

- (1) Secondary distribution
- (2) Primary lines
- (3) Substation busses
- (4) Generating stations

Any flicker in bus voltage of the generating station can be expected to show up at practically all points served by that station. Similarly if a substation bus flickers, all of the radial loads from that substation are affected. Primary line flicker affects all customers remote from the source of flicker, and to a lesser extent, some of those nearer the source of supply. Secondary circuit flicker is usually confined to an area immediately adjacent to the source of the disturbances.

The location of flicker voltage, or the extent of the afflicted area, has a considerable influence on possible remedies. If the generating station busses are affected, there are usually no commercially practical means of remedying the situation on the power system, and the correction must usually be made at the utilization point. If a substation is affected, but the generation stations are not, then more tie lines or transmission at higher voltage can be employed, or a separate line run from the generating station to the affected area. Sometimes the utilization equipment itself can be corrected. If a primary line is affected, improvements can be made in either the power system or the utilization equipment. If the distribution system alone is affected the correction may be made either on the system or the utilization device. If the utilization device is standard equipment, it is usually best to correct the distribution

system, and thus improve other loads as well. If the utilization device is special, it is probably more efficient to correct the device.

IV. REMEDIAL MEASURES

A large variety of corrective equipment and procedures can be used to minimize flicker. Those most commonly considered are:

1. Motor generator sets
2. Phase converters
3. Synchronous condensers
4. Series capacitors
5. Shunt capacitors
6. Voltage regulators
7. Booster transformers
8. Motor starters
9. Excitation control
10. Load control
11. Flywheels
12. System changes

3. Motor Generator Sets

A corrective scheme using m-g sets is illustrated in Fig. 22. In general, it is probably true that a motor-generator

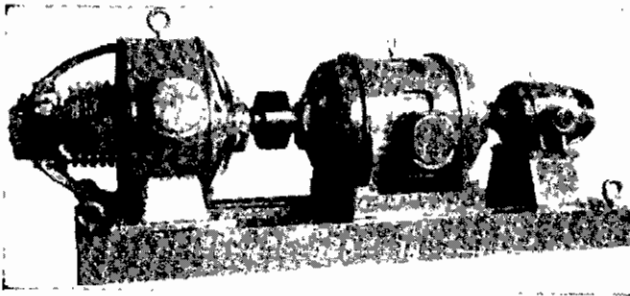

Fig. 22—Motor-generator set.

set between the utilization device and the power system gives the maximum possible reduction in flicker, because it is effective in minimizing three of the most undesirable load characteristics: single phase, low power factor, and sudden application. Since the only tie between the motor and the generator is the shaft, the disturbances due to single-phase load or to low power factor are not transferred to the power system. The reactance of the driving motor, in conjunction with the flywheel effect of the motor and generator delay the transfer of a change in load to the power system. The rate at which the voltage drops is therefore lessened and the eye is less likely to perceive this flicker.

The motor-generator set is probably the costliest arrangement, heaviest, least efficient, and occupies more floor space than any of the various corrective devices that can be used. But the m-g set has the advantage of consisting entirely of standard equipment, and is, therefore, reliable and well understood apparatus. The motor end may be synchronous, squirrel-cage induction, or wound rotor induction, the latter usually being provided with a flywheel and slip regulator. The generator end may be

suitable for the supply of either single-phase or polyphase loads.

When a synchronous motor draws additional power from the line it drops back in phase position. This causes a temporary drop in speed, but the flywheel effect of the rotor tends to oppose this change and to give up temporarily part of its rotational energy. This results in a "cushioning" of the rate of application of load to the power system, and a material reduction in peak demand can be effected for loads of short durations as compared with one-half of the natural period of electro-mechanical oscillation (see Chapter 13). The natural period usually ranges between $\frac{1}{2}$ and 1 second, so that for loads lasting about $\frac{1}{6}$ second and less, substantial reductions in peak demand can be expected. Thus, synchronous-motor-driven m-g sets are quite suitable for spot and seam welders having an "on" time of 1 to 10 cycles (60-cycle basis). Similarly, sudden increases or decreases of load are shielded from the power system if the load factor is high, but the load is subject to short violent irregularities. This is true of electric furnaces, for example, where the overall load factor is good, but there is considerable "choppiness," sudden power factor changes and short-circuiting of individual phases. For this type of load, synchronous motor drives are nearly as effective from the flicker standpoint as squirrel-cage induction, and preferable for other reasons.

When an induction motor draws added power from the line, it drops in speed. Its output, in the normal working range, is closely proportional to the slip, that is, to the difference between synchronous and actual speed. If load is suddenly applied to a generator driven by a squirrel-cage induction-motor, the system does not feel the full effect until the motor-generator set has slowed down from nearly synchronous speed to full-load speed. In the meanwhile, the inertia of the rotating parts supplies the energy, and thus the rate at which power is drawn from the system is materially reduced. Furthermore, as in the case of synchronous driving motors, if the generator load consists of a series of short pulses, the load is off before its full effect is transmitted to the power system, and the peak load on the system is thereby decreased. Because an induction motor must actually slow down, whereas a synchronous motor merely shifts in phase, the rate of load application to the power system is less for the induction than for the synchronous motor. On an average, it takes an induction motor-generator set about one second to transfer full load to the source. In Fig. 3, it is shown that this delay alone results in doubling the threshold of flicker perception, as compared with the perception due to sudden voltage dip of equal magnitude.

If the load pulses last several seconds, the power drawn from the system levels off to the amount of generator load plus losses for either a synchronous or squirrel-cage motor drive. The voltage drop in the power system during this steady load period is usually about the same for either the induction or synchronous motor drive, assuming that the excitation of the synchronous motor is constant. By increasing the synchronous-motor excitation with the load the final regulation of the system can be made very small. However, from the standpoint of flicker such excitation changes are usually imperceptible because of the time

required for correction. Thus, from the flicker standpoint, the principal superiority of the induction motor to the synchronous motor is the doubling of the threshold of perception, because of slower load application. This is particularly so for short pulses of power, say $\frac{1}{2}$ second and less, where the induction set draws considerably lower peaks than the synchronous set.

A further material reduction in flicker can be effected by the use of motor generator sets equipped with flywheels. In such cases a wound-rotor-induction motor is used, and additional rotor or secondary resistance is connected externally. By this means, the full-load slip of the motor can be increased from 1 or 2 percent to 10 percent or more. In order to transfer full load to the system, the set must then slow down considerably and the fullest advantage is thus taken of the inertia of the set and the additional flywheel. The extent to which improvement by this means may be carried is limited by cost and each case must be considered on its own merits. Limitation of peak demand is probably not feasible for loads in excess of about 3 seconds, but the reduction of rate of load application may nevertheless be of benefit.

Figures 23 and 24 bring out in graphic form the points discussed above. These curves were calculated using typical machine constants, and to facilitate computation, losses were neglected except when used to calculate speed changes on the induction sets.

The curves of Fig. 23 are for a load on $1\frac{1}{2}$ seconds and off $4\frac{1}{2}$ seconds. Curve (a) represents the load drawn by the synchronous set, and shows that it takes approximately 0.2 seconds for the system load to equal the generator load, and also that an "overswing" of about 35 percent makes up for the deficiency between input and output during the first 0.2 second. A similar swing occurs when the load is dropped. Curve (b) shows the load drawn by a standard squirrel cage induction motor subject to the same load

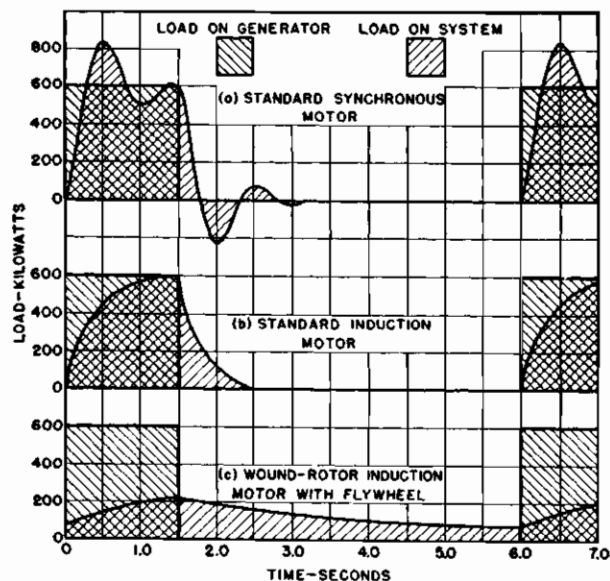

Fig. 23—Curves showing the relation between the power supplied by the generator and the power taken from the system for motor-generator sets using three types of motors. Generator load on for 1.5 seconds.

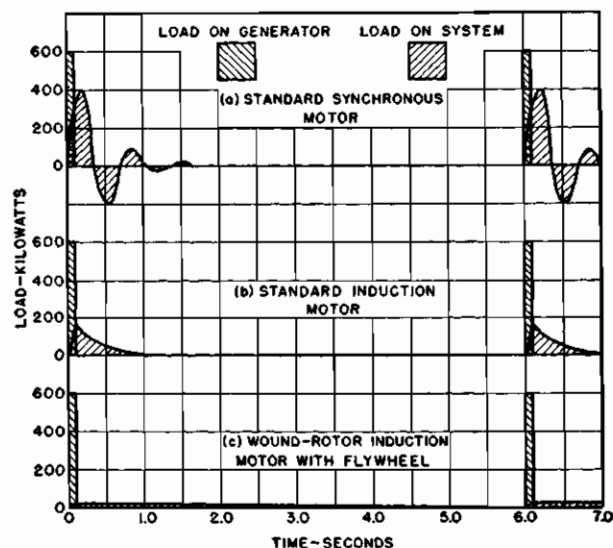

Fig. 24—Curves showing the relation between the power supplied by the generator and the power taken from the system for motor-generator sets using three types of motors. Generator load on for 0.1 second.

cycle. It can be seen that the system load builds up at about half the rate as for the synchronous motor, and that it does not become equal to the applied load until the end of the load application. The system load never exceeds the applied load disregarding, of course, m-g set losses, and the difference between input and output during the early part of the load cycle is compensated by a similar exponential continuance of load on the system for some time after the applied load has ceased. Curve (c) is for a wound rotor motor with a constant secondary resistance and a flywheel. The relation between slip, flywheel effect and load cycle is such that although the generator load goes on and off, the system load never drops to zero. The rate of load application is very low, and the system peak is only about a third of the load peak.

The curves of Fig. 24 are for a load cycle of 0.1 second on and 5.9 seconds off. Curve (a) is for a synchronous motor and shows that the peak system load is about two-thirds of the generator load. Curve (b) is for the squirrel cage set and shows a system peak of less than $\frac{1}{3}$ of the generator peak. Curve (c) is for the flywheel set and shows a system peak of about 3 percent of the load peak.

Figures 23 and 24 are of interest in illustrating the manner in which motor-generator sets transfer power from load to line, and suggest the conditions under which the various motors are most suitable. As pointed out previously, the phase balancing and power factor improvement qualities are usually the most valuable factors in the correction of flicker.

There are so many variables in load, power factor, duty cycle, etc., that general figures on the improvement that can be expected may be open to criticism. For very approximate purposes, however, it can be expected that if the load changes last one second or more, either synchronous or squirrel cage induction sets without flywheels reduce the voltage drop to $\frac{1}{6}$ for single-phase loads and to $\frac{1}{3}$ for polyphase loads. The perceptibility of the flicker is re-

duced still further by the slower rate at which the voltage dips, particularly with the induction set. For loads of very short duration such as $\frac{1}{6}$ second and less the voltage drop may be reduced to $\frac{1}{10}$ or even $\frac{1}{20}$.

Motor generator sets may be had with either single- or three-phase generators. Even when the generator is single phase, it is customary to use a three-phase star stator winding using only two legs in series. The third phase is wound for possible future use, or to increase synchronizing power if paralleled with other units, or dummy coils may be placed in the slots. If single-phase loads are to be carried, the field must be built with low resistance damper windings to minimize rotor heating. In the larger sizes, single-phase machines are mounted on springs to minimize vibration due to the pulsating torque caused by single-phase operation.

When more than one utilization device causing flicker is involved, the question of a single m-g set versus an m-g set for each such load must be answered. In these cases it is very important to consider the regulation of the generator of the set and how constant a voltage is required by the utilization devices. For example, it frequently happens that a factory is using several electric welders which produce 5 percent voltage dips of very objectionable frequency. This 5 percent drop usually does not affect the performance of the welders, and they could be operated at random on the power system. If a motor-generator set is to be used, however, the transient reactance of the generator is apt to be as high as 35 percent based on its rated current, and, assuming that the welder reactive current equals the generator rating, a 35 percent drop in voltage would occur. If only one welder is operated at a time, this is quite satisfactory, as the welder tap can be set on the basis of "closed circuit" voltage, that is, the regulation of the generator can be taken into account. If, however, another welder is operated simultaneously, even though on another phase, the additional voltage drop, uncompensated by the welder tap, is enough to spoil the weld. In order to operate several "choppy" loads simultaneously from the same m-g set, it is therefore necessary to use an oversize generator (from a thermal standpoint) to keep the regulation within required limits. Alternate solutions are to interlock utilization devices so that they cannot operate simultaneously or to provide separate m-g sets for each device. Another alternative is to use one common driving motor and several separate generators on the same shaft. The separate m-g set plan has the advantage of permitting operation at partial capacity in case of damage to one set, but is costlier.

4. Phase Balancers

In industrial plants a large percentage of the potential causes of flicker are single-phase devices. A discussion of phase balancers is, therefore, of interest, although there have been few commercially installed.

In a single-phase circuit the flow of power pulsates at a frequency twice that of the alternating supply, whereas in a balanced polyphase circuit the flow of power is uniform. Therefore, in order to effect a conversion between a single-phase and a polyphase system, some energy storage is necessary. This storage may be made in static de-

vices such as inductances and capacitors, or in rotating equipment with mechanical inertia. Except for small sizes, the static equipment has not yet been found commercially practical.

A lack of appreciation of this fundamental energy requirement has led to frequent proposals of schemes attempting single-phase to polyphase conversion by transformer connection. Fig. 25 is typical of these schemes. It

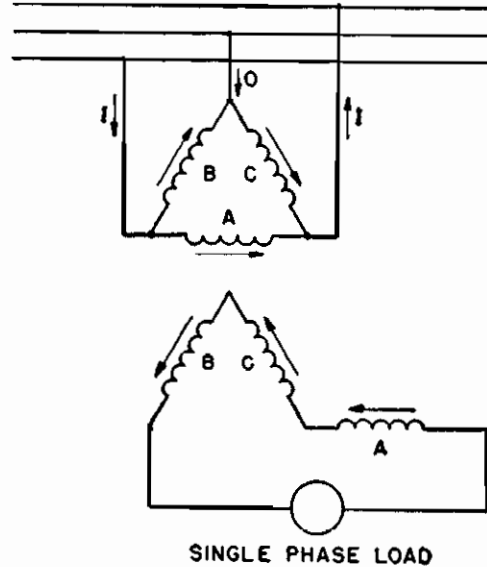

Fig. 25—Unsound attempt to supply balanced three-phase power to a single-phase load.

is not only completely ineffective for its intended purpose, but is also wasteful of transformer capacity. Although the transformers are all loaded equally, the currents drawn from the source as shown by the current arrows, are still single-phase, and a single-phase transformer is, therefore, preferable.

The most familiar type of phase converter is that shown in Fig. 26. It has been extensively used in railway electrifications to convert single-phase power from the contact system to three-phase power for the locomotive motors; this is merely the converse of the phase-balance. As shown, a rotating two-phase machine is connected through the equivalent of a Scott-connected transformer to the three-

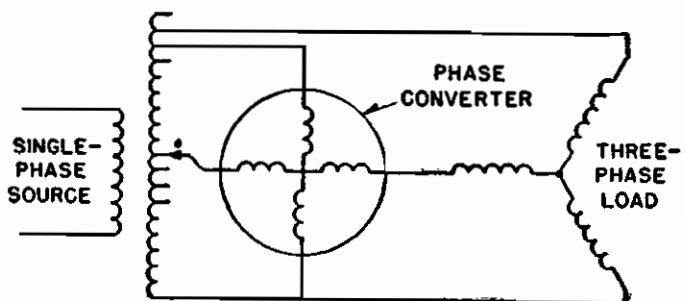

Fig. 26—Schematic diagram for phase converter used extensively on railway electrifications to convert single-phase power from the trolley to three-phase power for the locomotive motors. A rotating two-phase machine is connected through the equivalent of a Scott-connected transformer to the three-phase power system.

phase power system through the equivalent of a Scott-connected transformer, which also serves as the primary for the single-phase load winding. The two-phase machine may be of the induction type and act as a phase converter only, or it may be synchronous and used for power factor correction as well. Because of the regulation of the machine, the source currents are not balanced during variable-load conditions, unless the taps on the transformer winding are varied. From this point of view, it is not very suitable for "choppy" loads. Where there are several separate single-phase loads to be served, the capacity of a converter of this type must be equal to the sum of the individual loads.

The series type of phase converter is shown in Fig. 27. This is probably most efficient for conversion from three-

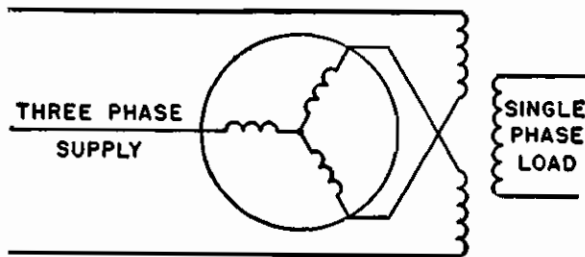

Fig. 27—Series type of phase converter from three phase to single phase.

phase to single-phase, where the single-phase load is not expected to grow, cannot be distributed between phases, and where no power factor correction is required. It consists of a counter-rotational induction-type series machine, connected through transformers in such a manner as to offer a high impedance to negative-sequence current between the single-phase load and the three-phase supply.

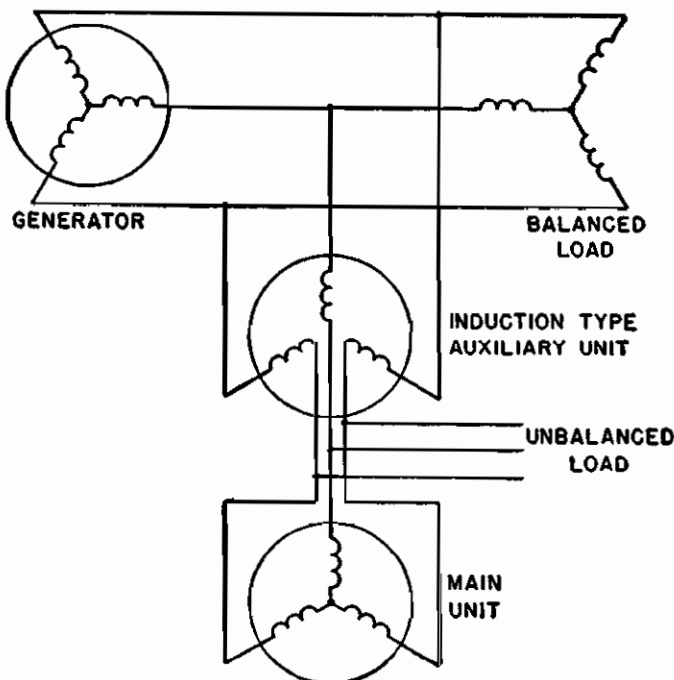

Fig. 28—Series impedance type of phase balancer.

When a single-phase load is suddenly applied, a magnetizing transient results, so that part of the negative-sequence component of load current is passed on the source. Although this transient subsides in about 0.1 second, it detracts considerably from the value of the scheme for use with "choppy" loads.

The series impedance balancer shown in Fig. 28 consists of an auxiliary induction-type machine in series with the polyphase supply and with the main shunt machine. The single-phase load is drawn from between the two. The series machine rotates oppositely to normal direction for positive-sequence applied voltage, and therefore, offers high impedance to negative-sequence currents and low impedance to positive-sequence currents. The shunt machine therefore takes the negative-sequence component of load current. The positive-sequence component of load current is taken by the system if the shunt is an induction type unit. If a synchronous type unit is used for the shunt machine, it can also take the wattless component of load current with suitable control of excitation. As with the series phase converter, the series machine does not immediately respond to load changes, and temporarily (for about 0.1 second) some unbalanced current is drawn from the source. The scheme, like the series phase balancer, is inherent in its action, no regulators being required unless power factor correction is used. This method has one important advantage over the previous two schemes in that the size of the shunt machine need only be enough to take care of the maximum unbalance of load. For example, if there are a number of individual single-phase loads as illustrated in Fig. 29, they may be distributed

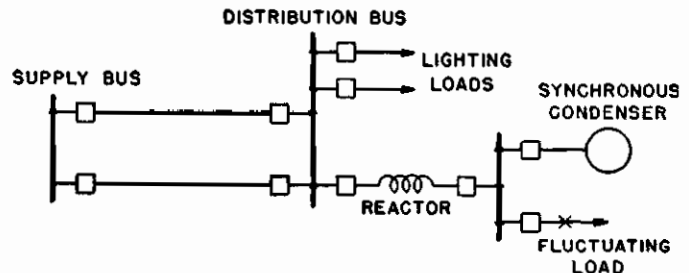

Fig. 29—Effective use of a synchronous condenser in connection with a fluctuating load.

between the phases, and the shunt machine need carry only the unbalance component. The series machine must, however, have enough capacity to carry the total positive sequence current.

Phase balancers, as a class, are not particularly suitable for flicker elimination except perhaps in borderline cases where only a moderate improvement (perhaps a one-half reduction in voltage dip) is required. In this case they may be the cheapest and most efficient remedy.

5. Synchronous Condensers

The voltage dip on a power system resulting from a suddenly applied load is equal to the vector product of the current and the system impedance giving proper consideration to vector positions. Consequently, one way of reducing flicker is to reduce the system impedance. Usu-

ally, the system impedance is predominantly inductive, and flicker is caused by current of low power factor so that most of the voltage drop is due to the reactive component of the system impedance. For example, suppose that the system impedance based on the load current is 1 percent resistance and 4 percent reactance and the load is at 50 percent power factor. A close approximation of voltage drop may be obtained by adding only those components of impedance drop that are in phase with the voltage. Thus, the resistance component of line drop is the 1 percent resistance times the 0.5 unit of current or $\frac{1}{2}$ percent, and the reactive component of line drop is the 4 percent reactance times the 0.866 unit of current (for 50 percent power factor) or 3.5 percent. The total voltage drop is therefore 4 percent, of which 3.5 percent is due to system reactance. This predominance of reactive component has led to frequent proposals to use synchronous condensers in parallel with the system as a means of reducing system reactance and thus improving flicker conditions. This method, while feasible in principle, is not usually economical in practice, as a brief consideration shows. The system reactance to a customer's service point may range from a fraction of a percent to 10 or more, but on an average is probably around 5 percent, based on the customer's kva demand. The subtransient reactance of a standard synchronous condenser is around 25 percent of its rating. Therefore, if a synchronous condenser of the same kva rating as the load is installed, the resultant reactance is $\frac{5 \times 25}{30} = 4.2$ percent and the flicker voltage is reduced to only $\frac{4.2}{5.0} = 84$ percent of its value without the condenser.

The effectiveness of a synchronous condenser can be much improved by the use of reactors between the power system and the load and operating the condenser from the load bus, as shown by Fig. 29. This scheme permits greater voltage fluctuations on the condenser and, therefore, causes it to bear a greater proportion of the fluctuating component of current. The customer's bus voltage, of course, undergoes the same voltage fluctuation, and this fact plus the fact that only a limited amount of series reactance can be used without unstable condenser operation, limits the extent of improvement. In most instances, it is likely that a reduction of flicker to one-half its uncompensated value is the economic limit of correction by this means. Where only this amount of correction is sufficient, the synchronous condenser and series reactor scheme may be the best economic solution, considering the power factor correction and control of voltage level afforded by the machine.

The suggestion has been made of using a driving motor for the synchronous condenser to permit higher values of series reactance without instability. This arrangement is the equivalent of a motor-generator set with a reactor paralleling the motor and generator ends. This scheme has never been used in practice, but calculations of performance and cost estimates indicate that there is little advantage compared with the straight m-g set or condenser-reactor schemes.

The benefits from the use of synchronous condensers

for flicker reduction depends in a large measure upon how low the subtransient and transient reactances can be made. The modern standard low-speed salient-pole synchronous condenser has been developed primarily for power factor correction and voltage control, and low-cost and low-loss condensers have relatively high reactance. A typical machine has subtransient and negative sequence reactances of about 25 percent and a transient reactance of 35 percent. A reduction in these reactances usually results in both higher costs and losses. The high-speed (3600 rpm) cylindrical-rotor type of machine inherently has lower reactances, perhaps one-half or less, but the cost and losses are both greater. In larger sizes and where other circumstances are favorable, the overall economy may justify the use of outdoor highspeed hydrogen-cooled synchronous condensers of low reactance.

Another way to decrease the reactance of the synchronous condenser is to use capacitors in series with the machine leads. The capacitive reactance partially nullifies the machine's inductive reactance giving a lower net reactance. This scheme theoretically should be quite effective and economical. However, the series capacitors may cause the synchronous condenser to hunt. The boundaries of satisfactory operation have not been fully explored, and predetermination is difficult. It is expected that after an experimental installation of this form of compensation is made that practical information will be available.

6. Series Capacitors

A general treatment of the use of capacitors in power systems is given in Chapter 8. The following discussion is concerned primarily with those aspects of capacitor application that are related to the problem of lamp flicker.

There are two main uses of series capacitors, depending whether they correct for the inductance of the supply or for that of the load. Their most familiar use is for line drop compensation; the application to equipment correction is more recent and shows much promise, as it improves conditions in the entire system, whereas the line capacitors benefit only those customers beyond the point of capacitor installation.

Being in series with the entire power circuit, series capacitors are instantaneous in their corrective effect. This is perhaps their most valuable advantage because any change in line current causes an immediate change in compensating voltage. Another advantage is that they generate lagging reactive kva proportional to the square of the current, thereby improving the power factor.

Series Capacitors Connected in Line—Fig. 30 shows in (a) a layout ordinarily favorable to the application of series capacitors. The transmission substation is assumed to have bus voltage regulation so that the voltage is fairly constant. The step-down transformer bank and the low-voltage line feed a distribution substation serving the fluctuating load and lighting loads; no loads are served at intermediate points between the substations. The series capacitor may be installed near the transmission substation, as shown in (b), or near the distribution substation. Another alternative is to install the capacitors between the transmission substation bus and the step-down transformer (depending upon which voltage is more suitable

for standard capacitors). The voltage along the line is shown by the diagram at (c), Curve A showing the uncompensated voltage and B the compensated voltage. The point of interest emphasized by (c) is that the compensating voltage is introduced in one step while the voltage drop along the line is uniform. For this simple case with

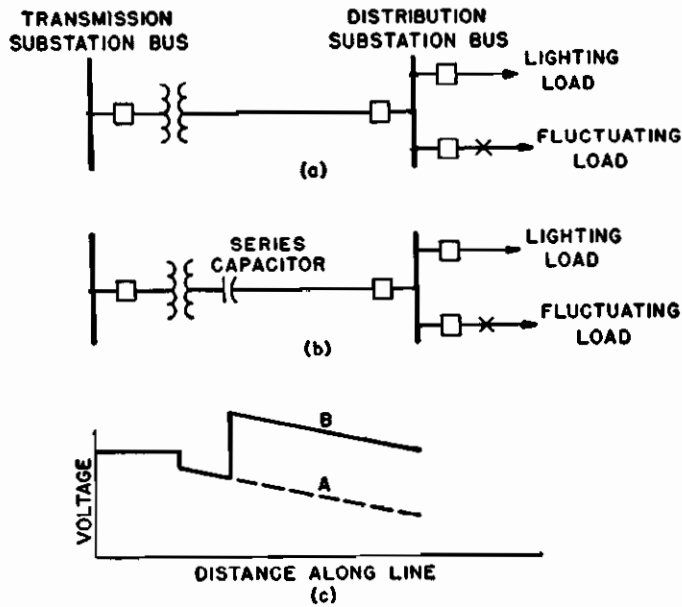

Fig. 30—Typical application of series capacitors.

- (a) Layout ordinarily favorable to application of series capacitors
- (b) Location of series capacitor
- (c) (A) Without capacitors; (B) with capacitors.

no intermediate line loads, the voltage gradient along the line is unimportant, and, subject to limitations outlined later, complete voltage-drop compensation at the distribution substation may be secured.

The vector diagrams for series capacitors at various power factors are shown in Fig. 31. These diagrams show that only the inductive component of line impedance is compensated by the capacitor. However, if the power factor of the load increment is low and constant, it is possible to over-compensate for the system reactance, and thus partly or completely nullify the resistance component of line drop. With variable loads and power factors this procedure can cause undesirable voltage-regulation characteristics and therefore each case of over-compensation must be considered on its own merits.

Where there are distributed loads along a line, it is necessary to consider the location of the capacitors. The capacitor gives its full voltage boost at the point of its installation, and therefore loads immediately ahead and behind the capacitor differ in voltage by the amount of boost in the capacitor. In general, the best capacitor loca-

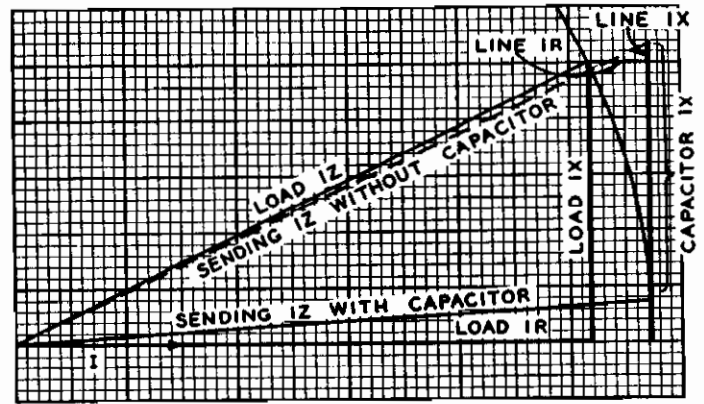

(a)

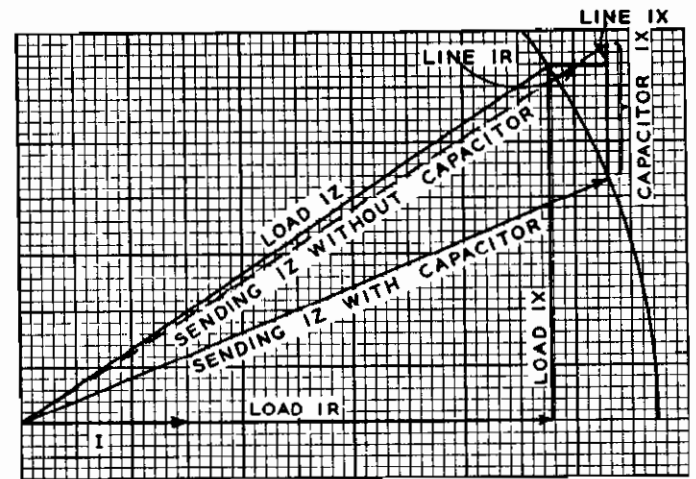

(b)

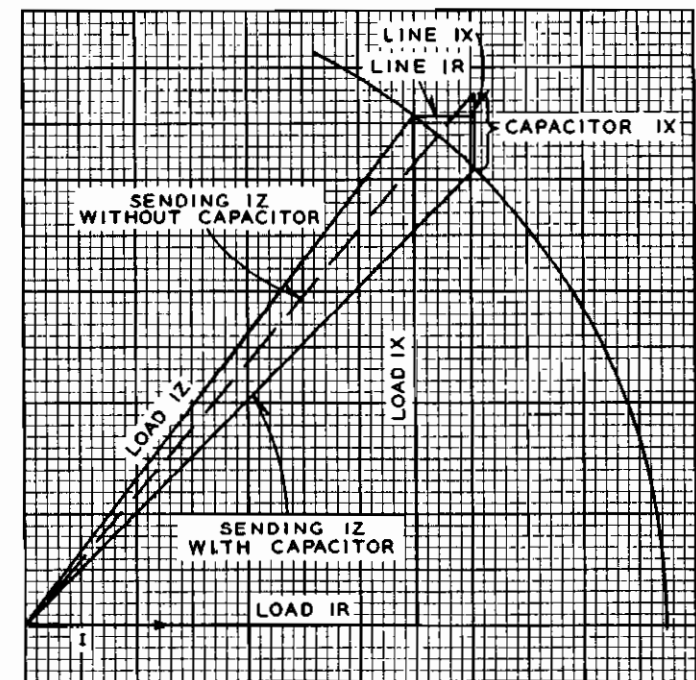

(c)

Fig. 31—The vector diagrams show the voltage drop across the series capacitor required if a capacitor is added so that the sending voltage will be the same as the load center voltage when the load power factor is (a) 90 percent; (b) 75 percent; (c) 60 percent.

tion is one-third the electrical distance between the source and the flicker-producing load, as shown by Fig. 32.

In principle series capacitors are effective in reducing flicker caused by practically all types of fluctuating loads. However, their effect is only beyond their point of instal-

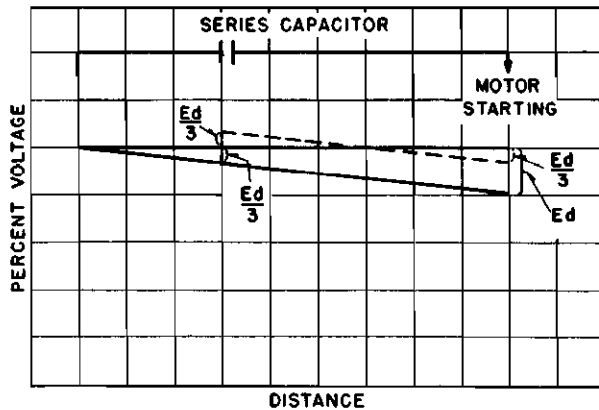

Fig. 32—Percent voltage regulation—in general, by placing the series capacitor about $\frac{1}{3}$ of the electrical distance between the source and the load, the voltage on both sides of it are kept within plus or minus limits in which flicker is not objectionable.

lation; hence they do not correct the system as a whole. For example, a series capacitor installed just ahead of substation *B* in Fig. 33 may remove most of the voltage fluctuation on that bus. However, at Station *A*, there may still be considerable voltage fluctuation, as the series capacitors do not correct the supply circuits. Another point to be noted from Fig. 33 is that the series capacitor must be large enough to carry all loads beyond its point of installation. Consequently, if the flicker-producing load

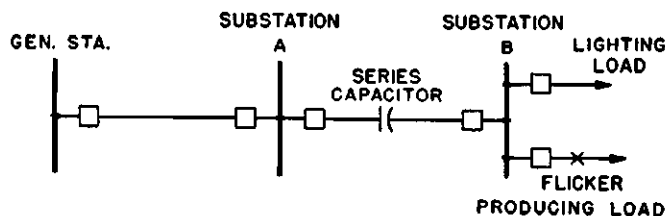

Fig. 33—Series capacitor must be large enough to carry total substation load.

is small as compared with normal load, the cost of the series capacitor is too high for the correction obtained. Series capacitors are therefore economical primarily where the flicker load is a large portion of the total, where the circuit resistance is equal or lower than the reactance, where the flicker-producing load is of low power factor, and where the supply circuits are fairly long.

Under certain circumstances series capacitors will produce, in conjunction with other apparatus, voltage or current surges in the line. The magnetizing inrush current of transformer banks, and the self-excitation of synchronous or induction motors are some of the factors causing this phenomenon, which is too involved for treatment here, but is discussed in items 4 and 5 of the table of references.

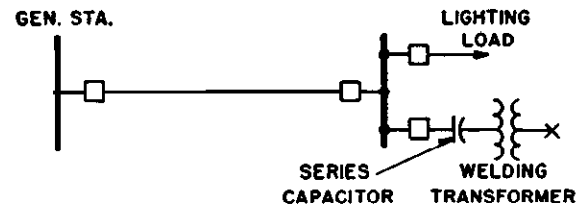

Fig. 34—Series capacitor installed with a welding load to reduce kilovolt ampere demand and improve power factor.

Capacitors in Series with the Equipment—This application is limited to utilization equipment with a constant inductive reactance, for which it is possible to compensate with a series capacitor, so that the load drawn from the supply circuit is practically at unity power factor at all times. Thus, although the power drawn from the line is still fluctuating, the resultant flicker voltage is greatly reduced. Figure 34 shows such compensation applied to a welding transformer. Inasmuch as the load itself is corrected, the benefits are felt all over the supply system. Several such applications have been successfully made to spot and seam welders (see reference 3).

7. Shunt Capacitors

Contrary to frequent misconceptions, permanently connected shunt capacitors are of no benefit whatever in minimizing flicker; in fact, they may make it slightly worse. An example shows the reason readily. A system with 10 percent inductive reactance in the supply leads, serving an intermittent load having an inductive reactance of 100 percent is shown in Fig. 35 (a). Resistance in both line and load will be neglected to simplify the example, but the same general effect will be observed if resistance

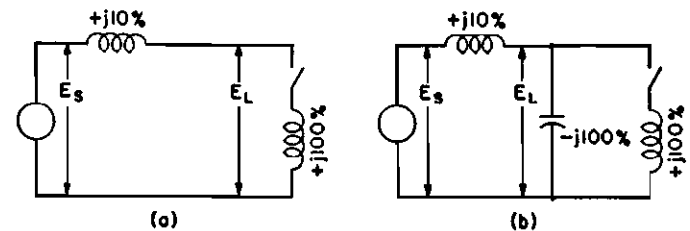

Fig. 35—Shunt capacitors are not effective in reducing voltage dips.

were present. When the switch is open $E_L = E_s$. When the switch is closed, the voltage at $E_L = \frac{+j100}{+j10 + j100} E_s = 91$ percent E_s . Fig. 35 (b) shows a similar circuit except a capacitor having a reactance equal and opposite to that of the load is permanently connected in the circuit. When the switch is open, the voltage $E_L = \frac{-j100}{+j10 - j100} E_s = 111$ percent E_s . When the switch is closed, the net load impedance is $\frac{(-j100)(+j100)}{-j100 + j100} = \infty$. This means that the combination of the capacitor and reactor draws no current from the source, and $E_L = E_s$. Thus, comparing the two cases, without the capacitor the voltage drops from 100 percent to 91 percent, a change of 9 percent. With ca-

capacitors, the voltage drops from 111 percent to 100 percent, a change of 11 percent.

Shunt capacitors connected to utilization equipment so that they are switched in accordance with load, reduce voltage drop. To be effective, the utilization device must draw a current that is substantially constant in magnitude and power factor during the "on" period, as, for example, some forms of resistance welders on which long runs are made without change of set-up. Motor starting is one example of an application to which shunt capacitors cannot be used effectively in this manner for flicker reduction. Motor inrush current approximates six times full load. If this is neutralized by a shunt capacitor, the initial voltage dip is greatly reduced. However, when the motor comes up to speed, the voltage rises above the initial voltage.

8. Voltage Regulators

Voltage regulators are also totally unsuited to correcting flicker. This statement applies both to generator voltage regulators, or to step- or induction-type feeder regulators. These devices operate only when the voltage changes; furthermore there is a time lag before voltage is restored to normal. As shown in Fig. 3, abrupt changes in voltage, the ones that voltage regulators cannot eliminate, are the very ones to which the human eye is most sensitive. Consequently, the flicker is perceived before the regulator can even start. It is sometimes thought that an electronic regulator and exciter can eliminate this difficulty and prevent voltage dips. However, the field time constant of the generator which in large units is as high as 10 seconds and even in very small machines may be one second, makes correction by this means impossible.

9. Compensating Transformers

As illustrated in Fig. 36, a compensating transformer is similar in effect to a line drop compensator used in voltage regulator control except that the size of the elements is that of a power device rather than that of an instrument. The current drawn by the flicker-producing load passes through a resistance and reactance branch, and the voltage

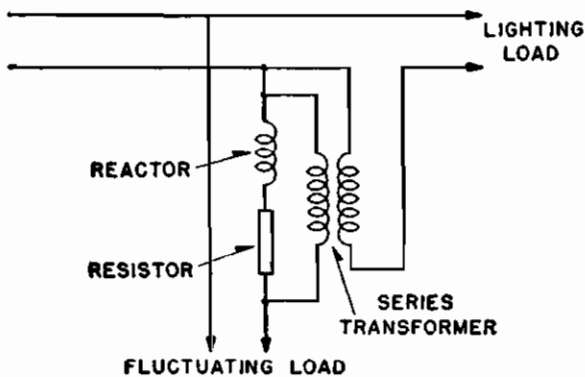

Fig. 36—Compensating transformer can be used in very special cases to reduce voltage dips.

drop thus created is added to the lighting-load voltage by means of a series transformer. By proper selection of the resistance, reactance, and series-transformer ratio, the flicker in the lighting circuit may be eliminated almost

completely. Satisfactory results can often be obtained by omitting the resistor, and in such cases, the apparatus becomes simply a transformer with an air gap in its magnetic circuit.

Despite the technical simplicity of this scheme, it has practical and economic limitations. It is apparent that the improvement in the lighting circuit is obtained at the expense of the flicker-producing load. This limits the application to cases where the lighting load is only a small proportion of the total. In general, the equipment must be individually designed for a specific set of conditions, since the proportions and size are affected by the line voltage, line drop, total current, and ratio of loads. Should system changes necessitate its removal, there is small likelihood of being able to use the compensating transformer elsewhere. The cost of the apparatus is rather high because it is not standard.

10. Motor Starters

As pointed out under "Utilization Equipment," most motors can be started directly across the line because even the larger sizes are usually supplied from heavy feeders compared to the size of the motor. Where this is not the case, a starter may be required if the starting is frequent. It is difficult to generalize on the question of motor starting, because individual cases vary with the motor size, type, and the starting torque of both motor and load.

Starting "compensators" are now being used much less than formerly. This is due largely to the acceptance of across-the-line starting, but also to the realization that the two voltage dips caused by the compensator may be as objectionable as one larger dip when starting across the line. In this respect reactor starting is superior, because the circuit is not opened at transition, and the reactor-short-circuiting operation may not result in a noticeable voltage dip if the motor is substantially up to speed. A reactor starter causes a greater initial voltage drop than a compensator, because the starting kva is decreased only directly as the starting voltage and not as the square of the voltage.

When the continuous-load rating of the feeder is the same as of the motor, the use of wound-rotor motors with stepped-resistance starters in the rotor circuits usually avoids annoying flicker. The cost of the motor and control is greater, but where the motor is near the end of a long line and is started frequently, this may be the most economical choice.

Where motors are started infrequently, but where the resultant voltage dip is still objectionable, some form of increment starter may be warranted. In a starter of this type, the stator current is increased in steps until the motor rotates, and the remaining impedance is cut out of the circuit after the motor has reached full speed. There are no standard starters of this type on the market, and the few that have been built have been specially designed for the particular service. In general, they represent a combination of auto-transformer and reactor starting, the switching being done without opening the circuit during the entire sequence.

Resistance starters in the stator circuits have been employed. On small integral horsepower motors the simplest

and cheapest of these is a single-step resistor which is cut out after the motor comes up to speed. As with reactor starting used on larger motors, the short-circuiting of the resistor does not usually cause a noticeable voltage dip, and the initial dip of course is considerably reduced. Resistance starters should be adjustable for individual requirements; in extreme conditions a variable resistor may be desirable. These starters are in general more expensive and more difficult to maintain by unskilled attendants.

11. Excitation Control

This involves single-step increments of the field excitation of synchronous motors by switches actuated by the equipment causing the flicker. This method is generally ineffective in eliminating flicker caused by abrupt voltage dips as explained under "Voltage Regulators." However, it can reduce considerably the width of the band of voltage regulation, which annoys power-supply companies by causing too frequent operation of feeder-voltage regulators as they attempt to compensate for the voltage swings. Such swings are caused by continuous strip rolling mills, large electric shovels, etc., where the variations of load are large, but where the rates of application and removal are moderate, say 10 to 30 percent per second.

12. Load Control

In some cases it is possible to minimize lamp flicker by controlling manufacturing processes. For example, in a plant operating two or three resistance welders, it may be possible to provide interlocks so that not more than one is operated at the same instant. A remedy of this kind is only possible if the "on" time is short compared to the "off" time, otherwise the production rate would be slowed up considerably. Similarly in arc-furnace work the violence of the current swings during melting can be reduced by lowering production rate during this phase of the cycle. It is also possible to perform flicker-producing operations

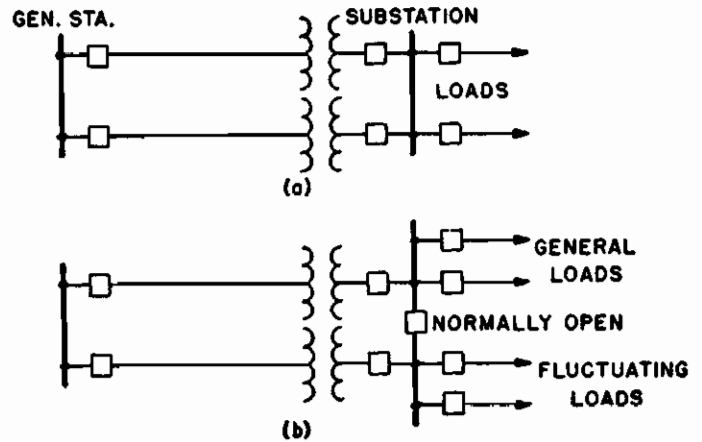

Fig. 37—System layout.

- (a) Fluctuating load on substation bus affected all loads fed from bus.
- (b) Fluctuating load feeders separated from rest of the load.

at a time when the lighting load is low. Control of load is not a very general solution to reduction of flicker, and it is employed in but few cases.

13. Flywheels

A general discussion of the effect of flywheels is given under "Motor-Generator Sets," but the same principles apply to direct-driven apparatus. This method has considerable value for mechanical loads having short durations with long "off" periods, such as shears, punch presses, etc.

14. System Changes

In practically all cases of flicker caused by utilization equipment, there is a direct relationship between the amount of the flicker and the size of the power supply system. For example, assume that a welder causes a three-

TABLE 2

Source of Flicker	Remedial Measures											
	1	2	3	4	5	6	7	8	9	10	11	12
	M-G Sets	Phase Converters	Synchronous Condensers	Series Capacitors	Shunt Capacitors	Voltage Regulators	Compensating Transformers	Motor Starters	Excitation Control	Load Control	Flywheels	Supply Circuit Changes
Generating Equipment												
Prime Movers.....	B	B	B	B	B	B	B	B	B	B	AX	B
Excitation Systems.....	B	B	B	B	B	B	B	B	B	B	B	B
Short Circuits and Switching Surges.	B	B	B	B	B	B	B	B	B	B	B	AX
Utilization Equipment												
Motor Starting.....	AZ	B	AZ	AX	B	B	AZ	AX	B	AZ	B	AY
Motor Driven Reciprocating Loads..	AZ	B	AZ	AY	B	B	AZ	B	B	B	AX	AY
Motor Driven Intermittent Loads...	AZ	B	AZ	AY	B	B	AZ	B	AZ	B	AX	AY
Electric Furnaces.....	AY	AZ	AX	AZ	B	B	AZ	B	B	AY	B	AX
Electric Welders.....	AX	AZ	AY	AX	B	B	AY	B	B	AY	B	AY

A—Technically Suited
 B—Technically Unsited
 X—Frequently Economical

Y—Possibly Economical
 Z—Rarely Economical

percent voltage flicker on a residential substation, where only one percent is acceptable. Tripling the size of the supply to the substation would reduce the flicker to the required level, and this would constitute one way of eliminating the flicker. If this were done by multiplying the number of incoming lines and transformer banks by three it would probably be the most costly of all possible corrective measures. Usually more economical system changes can be made.

A common form of substation supply with two or more feeders from the generating station paralleled to a single bus is shown in Fig. 37(a). With this arrangement, all loads fed from the substation are subjected to any flicker produced on the outgoing feeders. Figure 37 (b) shows a low voltage bus divided into two sections, one for residential and commercial loads, the other for industrial loads. This layout is based on the fact that voltage fluctuations objectionable to residential customers are acceptable to industrial users. There is probably a greater flicker tolerance in shop work than in residence lighting, and industrial plants are usually willing to accept flicker when it is caused by their own operation.

Other methods of stiffening the power system involve changing the voltage of the supply line, tapping nearby high-voltage, high-capacity lines, adding more transformer capacity, or running a separate line to the flicker-producing load. Local conditions determine what remedial measures are most suitable in a particular case. Occasionally system increases are justified if the additional capacity may be needed later anyway.

15. Comparison Chart

A reference chart showing at a glance the remedial measures available and those most promising for a particular type of flicker is shown in Table 2. Inasmuch as the best technical solution may not be the most economical, the remedies are compared from both points of view.

REFERENCES

1. *The Visual Perception and Tolerance of Flicker*, prepared by Utilities Coordinated Research, Inc.—New York, 1937.
2. Lamp Flicker Awaits Ideal Motor Starter, by L. W. Clark, *Electrical World*, April 9, 1938.
3. Power-Factor Correction of Resistance-Welding Machines by Series Capacitors, by L. G. Levoy, Jr., *A.I.E.E. Transactions*, 1940.
4. Analysis of Series Capacitor Application Problems, by Concordia and Butler, *A.I.E.E. Transactions*, 1937. Vol. 56.
5. Self-Excitation of Induction Motors with Series Capacitors, by C. F. Wagner, A.I.E.E. Paper No. 41-139. Presented at Summer Convention, Yellowstone Park.
6. A Lamp Flicker Slide-Rule, by C. P. Xenis and W. Perine, Presented at E.E.I. Transmission and Distribution Committee Meeting, Chicago, May 5, 1937.
7. Power Supply for Resistance-Welding Machines, Committee on Electric Welding, *A.I.E.E. Transactions*, 1940. Vol. 59.
8. Power Supply for Resistance-Welding Machines—Factory Wiring for Resistance Welders, Committee on Electric Welding, A.I.E.E. paper 41-82—Contains a Number of Examples.
9. Power Supply for Welding, by A. S. Douglass and L. W. Clark, *The American Welding Society Journal*, October 1937.
10. Large Electric Arc Furnaces—Performance and Power Supply, by B. M. Jones and C. M. Stearns, *A.I.E.E. Transactions*, 1941. Vol. 60.
11. Arc Furnace Loads on Long Transmission Lines, by T. G. Le Clair, *A.I.E.E. Transactions*, 1940. Vol. 59.
12. 10 000 kva Series Capacitor Improves Voltage in 66 Kv. line Supplying Large Electric Furnace Load, B. M. Jones, J. M. Arthur, C. M. Stearns, A. A. Johnson, *A.I.E.E. Transactions*. Vol. 67, 1948.
13. Voltage Translator Scheme Cuts Light Flicker due to Welders, R. O. Askey, *Electrical World*, January 6, 1945, page 63.
14. Electric Arc Furnaces and Equipment Producing Heavy Fluctuations, Part II—the solutions, by B. M. Jones. Presented before E.E.I. Electrical Equipment Committee, Old Point Comfort, Va., October 10, 1950.
15. Power Company Service to Arc Furnaces, by L. W. Clark, *A.I.E.E. Transactions* 1935.

COORDINATION OF POWER AND COMMUNICATION SYSTEMS

Original Author:

R. D. Evans

Revised by:

R. L. Witzke

THIS chapter deals with the coordination of power and audio-frequency communication systems, including telephone, telegraph, supervisory-control, and pilot-wire relaying circuits. The presentation is from the standpoint of the power engineer with particular attention to the characteristics of power apparatus. Part I, Basic Principles, gives a general background of the coordination problem in order to provide proper perspective to the subjects treated. Detail discussion of the problem is given in Part II, Low-Frequency Coordination, and Part III, Noise-Frequency Coordination.

I. BASIC PRINCIPLES

When a power and a communication circuit are operated in proximity, the power circuit may produce certain conductive or inductive effects, which may interfere with the normal operation of the communication circuit. These electrical *interference* effects, which appear as a result of extraneous voltages and currents in the communication circuit, may be minimized by measures that are applicable to either circuit alone, or to both. Such measures provide the basis for the *coordination* of power and communication circuits to avoid interference, as discussed in this chapter.

1. Interference and Coordination

Definitions of *interference* and *coordination* as adopted by the National Electric Light Association and Bell Telephone System ^{1(a)}, with slight rephrasing, are:

Interference is an effect arising from the characteristics and interrelation of power and communication systems of such character and magnitude as would prevent the communication system from rendering service satisfactorily and economically if methods of coordination were not applied.

Coordination is the location, design, construction, operation, and maintenance of power and communication systems in conformity with harmoniously adjusted methods which will prevent interference.

2. Nature and Importance of the Problem

The electrical-coordination problem arises principally because two distinct types of circuits or systems are employed, namely, (1) *power systems* for generation, transmission, and distribution of electrical energy, and (2) *communication systems* in which electrical energy is used incidentally for the transmission of signals. Another important consideration arises from the fact that the user of electrical energy is generally also a user of electrical communication. For example, power lines for delivering electricity to homes and factories are roughly paralleled

by telephone circuits required to give electrical communication for the same places. The coordination problem becomes cumulatively more severe as the power systems supply increasing amounts of load and the communication systems become increasingly sensitive. There is also the complication caused by the introduction of newer uses for electrical energy and for electrical communication.

The effects of extraneous voltages and currents on communication systems are varied in character, and include hazard to persons, damage to apparatus, and interference with service. The damage to the physical plant includes the effects resulting from overheating, from breakdown of insulation in lines and apparatus, and from electrolysis. The interference with service includes such effects as noise and acoustic shock in the telephone circuits, false signalling in telephone, telegraph, and supervisory-control circuits, as well as disruption of service. Communication circuits are usually equipped with devices that, when subjected to excessive voltages, provide protection, but in so doing may render the circuit inoperative for communication purposes not only for the duration of the abnormal voltage condition but also until maintenance work can be done.

The coordination problem is extremely widespread; practically every type of electrical circuit has interfered with some other type of electrical circuit. For example, power-supply circuits have interfered with audio- and carrier-frequency telephone and telegraph circuits, machine-switching and supervisory-control circuits. Similarly, d-c and a-c railway circuits have interfered with practically every type of communication circuit. It is an interesting and significant fact that communication circuits interfere with one another, not only in the form of "cross fire" between telegraph circuits but also in the form of "crosstalk" between telephone circuits on the same pole line. Power circuits can interfere with each other. For example, a ground fault on a transmission circuit can impress high induced voltages on a neighboring low-voltage distribution circuit and produce apparatus failure or circuit outage.

3. The Origin of Extraneous Voltages

Extraneous voltages in communication circuits arising from power circuits are caused by:

Conduction

- (a) Metallic cross
- (b) Ground potential

Induction

- (a) Magnetic induction, a current effect
- (b) Electric induction, a voltage effect.

Conduction is an important factor where circuits of the two types are located close together as, for example, where the circuits cross each other or are located on the same pole line, or where one pole line is overbuilt by

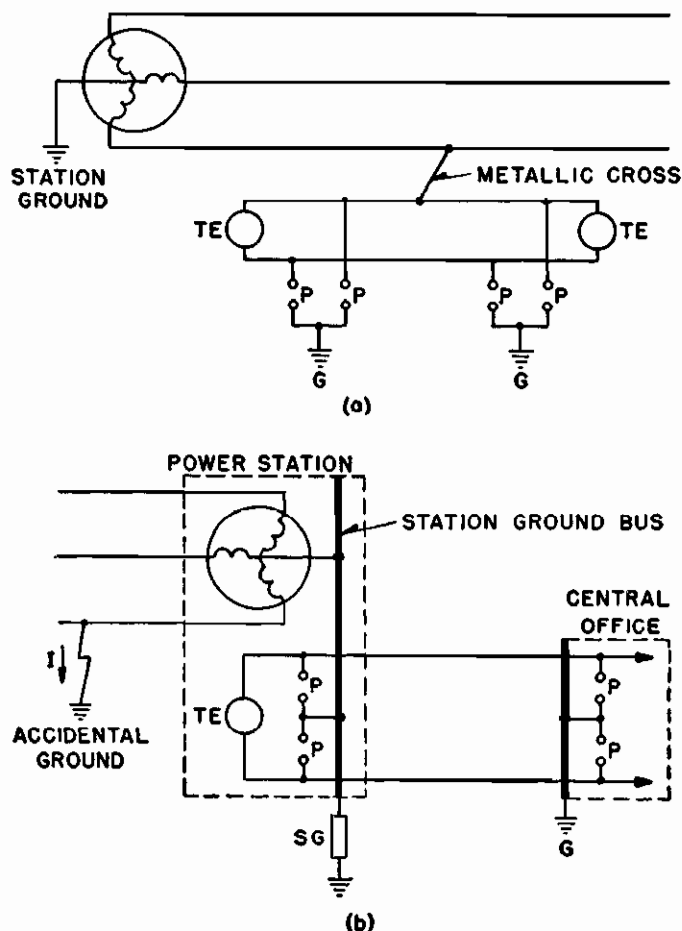

Fig. 1—Schematic diagrams illustrating the production of extraneous voltages in a communication circuit by conduction from a power circuit.

- (a) By metallic cross.
 (b) By rise in ground potential through use of ground connections common to both types of circuits.

TE Telephone terminal equipment.
 P Protectors on communication circuit.
 SG Station-ground resistance.

another. Under these conditions a conductor failure or an extraneous wire may produce a metallic cross between the different types of circuits as illustrated in Fig. 1 (a).

A second and somewhat less obvious method of impressing extraneous voltages and currents on a communication system results by conduction from a common use of earth connections. Power circuits, except railway traction circuits and multi-grounded neutral circuits, do not make intentional use of the earth under normal conditions except as a means for stabilizing the power-system neutral, and under fault conditions to limit the voltages and to provide adequate currents for relaying purposes. For this reason large ground-potential effects are almost invariably associated with fault currents through ground connections.

On a power system a fault to ground causes a rise of potential of the power-station neutral or ground bus as shown in Fig. 1 (b). This potential rise can be estimated from the magnitude of the ground current and of the station-ground resistance SG which is of finite but low value. This rise of ground potential may be impressed on a communication circuit in the following manner. If a telephone circuit connects the power station and a remote central office, telephone protectors are connected to the power-station ground bus to avoid hazard to the user of the telephone circuit at the power station. Similarly, telephone protectors are used at the central office for protection against lightning and other extraneous voltages. Consequently, upon the occurrence of a ground fault, the rise in potential at the power station produces a voltage that is impressed upon the telephone circuit and the two sets of protectors as shown in Fig. 1 (b). This type of problem occurs frequently in connection with power-company communication systems, and in supervisory-control and pilot-wire relaying systems.

A fault causing ground currents in a power circuit also impresses upon a paralleling telephone circuit a component of voltage in phase with the ground current of the power circuit. These conductive or ground-potential effects are closely related to inductive effects and in many cases are difficult to separate. As a matter of convenience, both effects are considered under inductive effects in the subsequent discussions.

Magnetic induction, or electromagnetic induction, as used in this chapter, applies to the voltages induced in a communication circuit as a result of currents flowing in a power circuit. Consider a single-phase metallic* power circuit carrying a current of I amperes, and a metallic* communication circuit located in proximity, as shown in Fig. 2. Magnetic fields around the power conductors are as shown for an elementary section in Fig. 2 (b). The communication conductors C_1 and C_2 lie in positions of different field strengths so that unequal voltages are induced in these conductors.

When ground forms a part of the return circuit for the flow of power current, as when a line-to-ground fault occurs, the problem is quite similar and can be calculated on the basis of a concentrated return current in the earth located at some relatively great distance directly below the line conductor. The determination of the coefficient of induction or the coupling-factor under these conditions constitutes one of the more important problems in the analysis of fundamental-frequency effects.

Electric Induction—An important source of extraneous voltage on communication circuits, under normal operating conditions, may be electric induction from a neighboring power circuit. By this is meant the voltage impressed on a communication circuit because of its position in the electric field, or electrostatic field, produced by the circuit voltages of the power system. A section of line with power conductor P energized from a single-phase grounded source and with communication conductors C_1 and C_2 is shown in Fig. 3. It is to be recognized that there

*By metallic circuit is meant one in which wires constitute the two sides of the circuit; that is, earth does not constitute one side of the circuit.

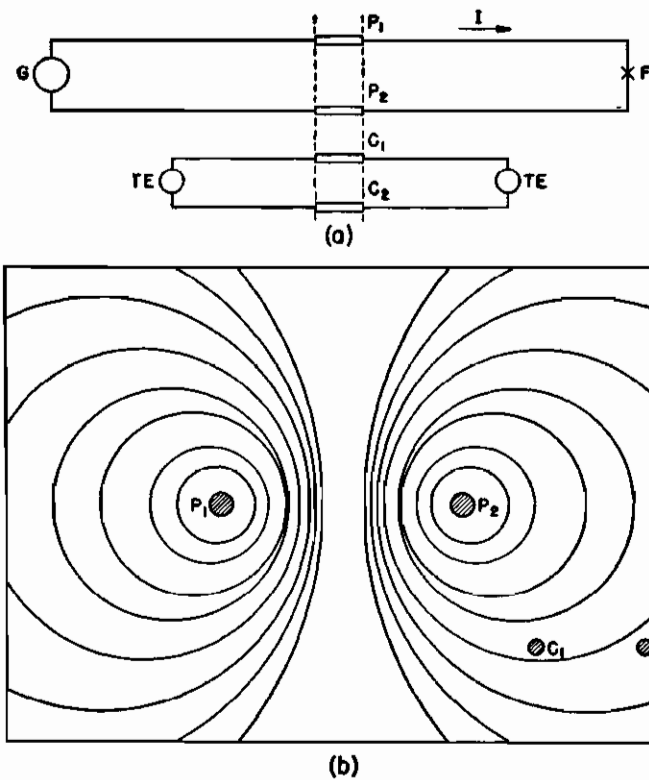

Fig. 2—Schematic diagram illustrating magnetic induction from a metallic power circuit on a metallic communication circuit.

- (a) Elementary section.
- (b) Equi-potential fields.

are capacitances between conductors, and between conductors and ground. In Fig. 3 (b) is shown a cross-sectional view of the line together with equi-potential lines in the electric field produced by the conductor having a potential with respect to ground. If the communication circuit consists of two wires separated even a short distance, different potentials are induced on them for most locations. A typical power circuit involves three phase-wires, and the electric induction produced by the three phases determine the resulting potentials impressed on adjacent communication conductors.

Power-system voltages or currents which produce inductive effects in communication circuits can be classified as (1) positive- and negative-sequence components that are normally confined to the line conductors, and (2) the zero-sequence component for which the line conductors constitute one side of the circuit and the neutral or ground wires, or earth the return. Obviously the coefficients of induction from power-system currents are different for these two cases. Telephone engineers are accustomed to use the term "balanced components" for the positive- and negative-sequence components and the term "residual component" for the quantity equal to the sum of the zero-sequence components in the three phases. Under normal-circuit conditions the negative-sequence component of fundamental frequency is usually negligible with the result that the balanced components are normally related to the positive-sequence component only. Under ground-fault

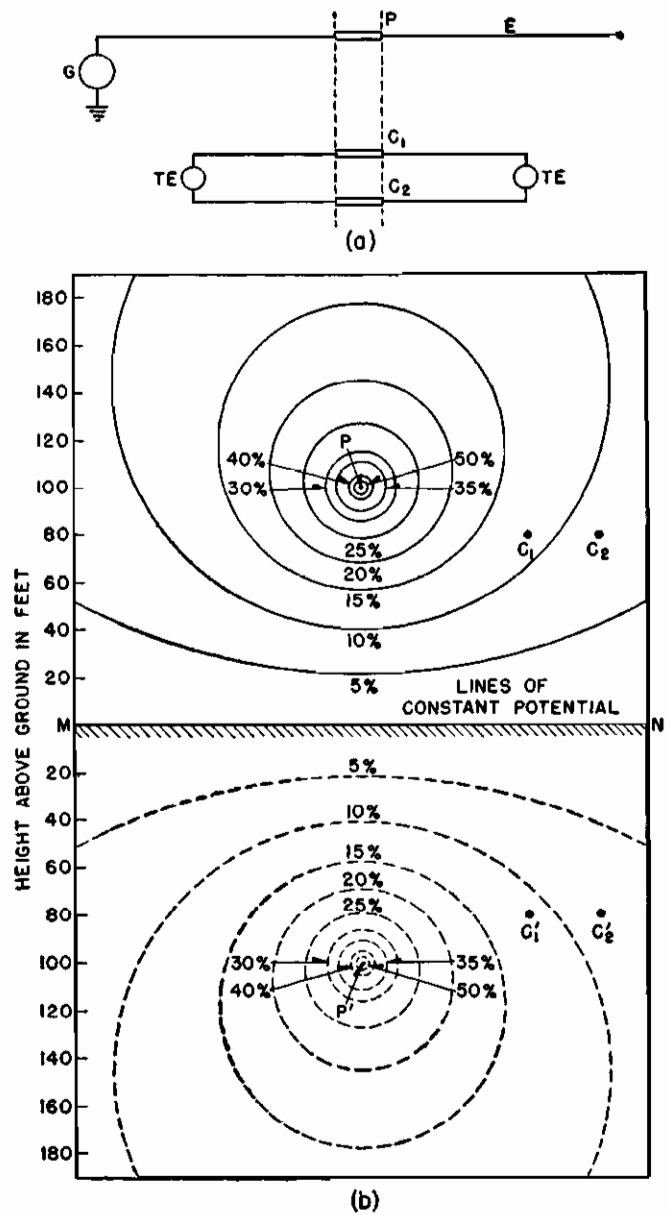

Fig. 3—Schematic diagram illustrating electric induction from a single-phase ground-return power circuit on a communication-circuit conductor.

- (a) Elementary section.
- (b) Equi-potential fields.

conditions the zero-sequence component of fundamental frequency is predominately important because greater coefficients of induction apply for the component that flows through the earth. Harmonic components may be of any of the three sequences as shown later.

Voltages induced in metallic communication circuits can conveniently be resolved into components in a manner analogous to that for symmetrical components of poly-phase circuits. In the case of the metallic telephone circuit the resolution is made into (1) a longitudinal component, and (2) a metallic-circuit component. The longitudinal components of voltage in the two sides of the circuit are identical and the corresponding components of voltages to

ground are identical. The metallic-circuit components of voltage and current associated with each line conductor are equal in magnitude but opposite in phase so that they tend to circulate current around the metallic circuit.

An equivalent circuit for analyzing the effects of electrically induced voltages on a metallic-telephone circuit is shown schematically in Fig. 4 (a). In this diagram, the

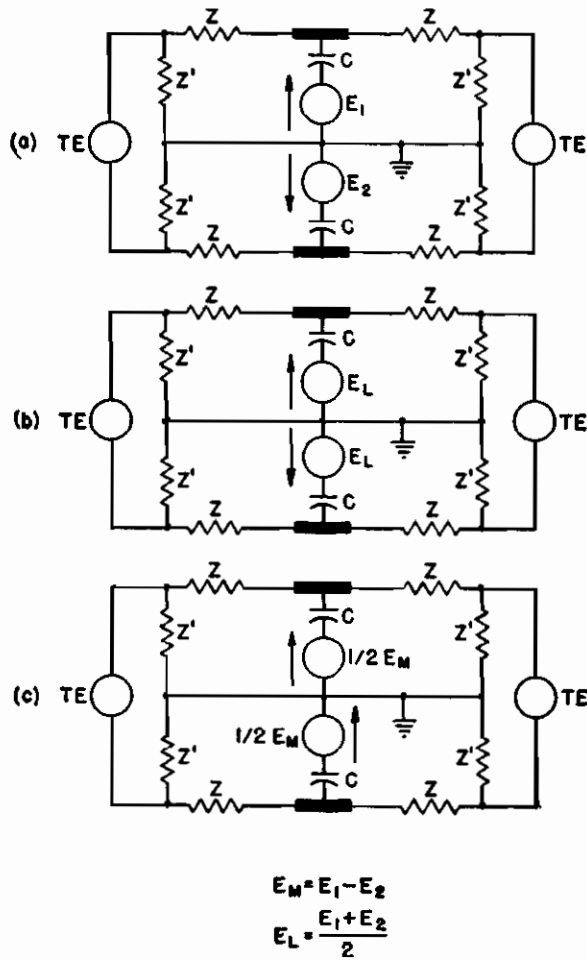

Fig. 4—Equivalent circuit for simulating electric induction and method of resolving induced voltages into longitudinal- and metallic-circuit components.

- (a) Equivalent circuit with total induced voltages.
- (b) Same circuit but with longitudinal-circuit components of induced voltages.
- (c) Same circuit but with metallic-circuit components of induced voltages.

TE Telephone terminal equipment.
 Z Series-impedance circuit element.
 Z' Shunt-impedance circuit element.

induction is assumed to occur in the elementary section at the middle of the line with unequal voltages, E_1 and E_2 , induced on the conductors. The communication circuit is represented as having series impedance elements Z and shunt impedance element Z' , as shown in the diagram, together with terminal equipment TE. The equivalent circuit for electric induction requires the addition of sources of voltage E_1 and E_2 acting through capacitances C . The

two electrically induced voltages E_1 and E_2 may be resolved into longitudinal-circuit components, as shown in Fig. 4 (b), and into the metallic-circuit components, as shown in Fig. 4 (c). The equations relating the longitudinal- and metallic-circuit components and the total induced voltages for each conductor are also included. The impedances of the various circuit elements can be different for the longitudinal and metallic circuits.

The corresponding equivalent circuit for analyzing the effect of magnetically induced voltages is shown in Fig. 5 (a). This diagram corresponds closely with Fig. 4 (a), except that the voltages are shown as being impressed in series with the line in the elementary section. Voltages magnetically induced in the two conductors can be resolved into longitudinal- and metallic-circuit components as illustrated in Figs. 5 (b) and (c), respectively. The equations relating longitudinal- and metallic-circuit components and the total induced voltages in each conductor are also included.

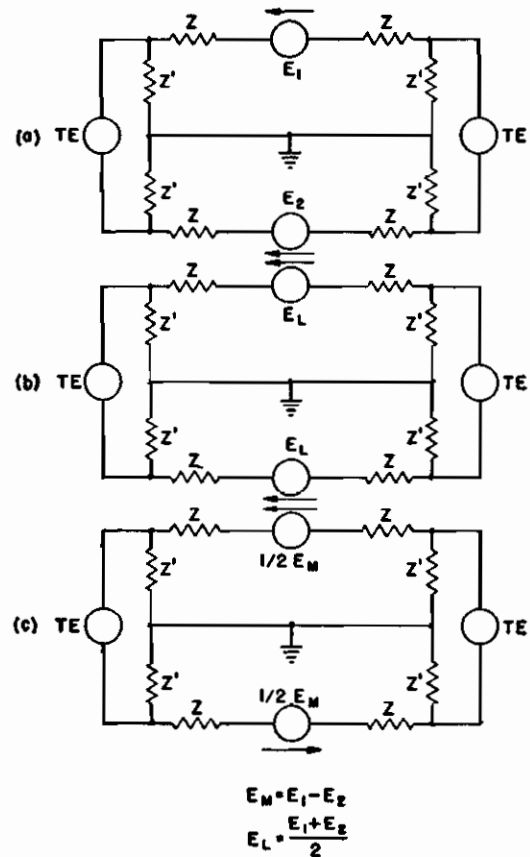

Fig. 5—Equivalent circuit for simulating magnetic induction and method of resolving induced voltages into longitudinal- and metallic-circuit components.

- (a) Equivalent circuit with total induced voltages.
- (b) Same circuit but with longitudinal-circuit components of induced voltages.
- (c) Same circuit but with metallic-circuit components of induced voltages.

TE Telephone terminal equipment.
 Z Series-impedance circuit element.
 Z' Shunt-impedance circuit element.

4. Basic Factors—Influence, Coupling, and Susceptiveness

The coordination problem can be considered from the standpoint of the three basic factors, influence, coupling, and susceptiveness. Definitions of these factors, slightly rephrased from the form given in Reference 1 (a), are:

Influence factors are those characteristics of a power circuit with its associated apparatus that determine the character and intensity of the inductive and conductive fields which they produce.

Coupling factors express the interrelation of neighboring power and communication circuits from the standpoint of induction or conduction.

Susceptiveness factors are those characteristics of a communication circuit with its associated apparatus which determine the extent to which it is capable of being adversely affected in giving service by inductive or conductive fields from power systems.

This segregation of the essential factors constitutes an important step in the solution of the coordination problem since it makes possible the analysis of the contributions from the power system, from the interrelation of the two systems, and from the communication system. This segregation also allows the setting up of standard practices for power and communication systems.

The power-system *influence factors* include the fundamental-frequency voltages and currents during normal operation; their values under fault conditions including duration and frequency of occurrence and divisions among earth-return paths. They include also the magnitude and phase relation of harmonic voltages that may be produced by rotating machines, transformers, and rectifiers and other apparatus and the frequency-impedance characteristic of the system, particularly in respect to resonance for certain harmonics. The symmetry of the system or the balance of phases with respect to ground represents another type of influence factor. *Coupling factors* include the coefficients of magnetic and electric induction at varying separations and the conductive or mutual-resistance factors as well. They comprise those factors which are quantitatively determined by geographical and geometrical relationships, relative conductor positions and earth resistivity. Shield wires, which are not located as a part of either system, and transpositions are also considered under this heading. The *susceptiveness factors* of communication systems include (1) for normal operation the characteristics of sensitivity, power level, frequency response, and balance of the circuit with respect to ground; and (2) for abnormal conditions those characteristics that can be adversely affected by the presence of high extraneous voltages, including the features that may result in hazard, damage to plant, and interference with service. These characteristics are important not only during the presence of abnormal voltage but also because of their reaction on the ability of the circuit to return to the normal condition after the extraneous voltage has been removed. Damage to the physical plant includes overheating of conductors, the breakdown of insulation in lines and apparatus, and the operation of protective equipment. Interference with service includes telephone noise, acoustic shock, false signalling, as well as actual disruption of service. By acoustic shock is meant the adverse reaction on a listener to a telephone

receiver when subjected to excessive currents, normally associated with fundamental-frequency induction of sufficient magnitude to break down telephone-circuit protectors.

5. Procedure for Solution of Coordination Problems

In the United States the solution of coordination problems has been promoted effectively by the pioneering cooperative work of the most vitally interested utilities, the National Electric Light Association (and its successor, the Edison Electric Institute) and the Bell Telephone System. The basic features of the resulting procedure are (1) recognition of the duty of coordination and (2) effective measures for cooperation. These features are covered in the following excerpts from "Principles and Practices for the Coordination of Supply and Signal Systems."^{*1(a)}

Duty of Coordination

(a) In order to meet the reasonable service needs of the public, all supply and signal circuits with their associated apparatus should be located, constructed, operated and maintained in conformity with general coordinated methods which maintain due regard to the prevention of interference with the rendering of either service. These methods should include limiting the inductive influence of the supply circuits or the inductive susceptiveness of the signal circuits or the inductive coupling between circuits or a combination of these, in the most convenient and economical manner.

(b) Where general coordinated methods will be insufficient, such specific coordinated methods suited to the situation should be applied to the systems of either or both kinds as will most conveniently and economically prevent interference, the methods to be based on the knowledge of the art.

Cooperation

In order that full benefit may be derived from these principles and in order to facilitate their proper application, all utilities between whose facilities inductive coordination may now or later be necessary, should adequately cooperate along the following lines:

(a) Each utility should give to other utilities in the same general territory advance notice of any construction or change in construction or in operating conditions of its facilities concerned, or likely to be concerned, in situations of proximity.

(b) If it appears to any utility concerned that further consideration is necessary, the utilities should confer and cooperate to secure inductive coordination in accordance with the principles set forth herein.

(c) To assist in promoting conformity with these principles, an arrangement should be set up between all utilities whose facilities occupy the same general territory, providing for the interchange of pertinent data and information including that relative to proposed and existing construction and changes in operating conditions concerned or likely to be concerned in situations of proximity.

The solution of coordination problems is based on:

1. The establishment of standard coordination practices for both power and communication circuits.
2. The joint determination of appropriate methods for specific situations.

The general coordinated practices of power and communication systems are outlined in the publications of the

*The term "signal system" is frequently used in coordination work as a general term to denote any type of communication circuit.

N.E.L.A. and Bell Telephone System^{1(a)}. All construction is expected to meet these standards unless, in the absence of an interference problem, they are postponed on the basis of deferred coordination. Where general coordinated measures are insufficient, the "best engineering solution" utilizing specific coordinated measures should be applied as outlined in the following excerpt^{1(a)}:

Choice Between Specific Methods

When specific coordinated methods are necessary and there is a choice between specific methods, those which provide the best engineering solution should be adopted.

(a) The specific methods selected should be such as to meet the service requirements of both systems in the most convenient and economical manner without regard to whether they apply to supply systems or signal systems or both.

(b) In determining what specific methods are most convenient and economical in any situation for preventing interference, all factors for all facilities concerned should be taken into consideration including present factors and those which can be reasonably foreseen.

(c) In determining whether specific methods, where necessary, shall be wholly by separation or partly by methods based on less separation, the choice should be such as to secure the greatest present and future economy and convenience in the rendering of both services.

The cooperative work initiated by the National Electric Light Association and the Bell Telephone System, subsequently followed by other utility groups, has provided a practical solution of the coordination problems that have been encountered. In addition, these organizations have carried out an extensive research and development program which has developed basic theoretical and statistical information bearing on the coordination problem. The results of this work carried on by the Joint Subcommittee on Development and Research have provided the most authoritative information available on many phases of the coordination problem. Their Reports⁴ contain in addition much information of value in the power and communication field outside of coordination work, a circumstance that unfortunately has not been recognized as widely as the subject matter deserves.

6. Types of Coordination Problems

Discussion of the coordination problem between power and communication systems can be classified into four groups⁴:

1. Electrolysis
2. Structural
3. Low frequency
4. Noise frequency

Electrolysis Coordination is concerned with the layout and operation of power circuits, power and communication cables, and underground structures, located close together, from the standpoint of accelerated corrosion resulting from leakage currents. This problem is of considerable importance with d-c circuits but not with a-c. Corrosion occurs in areas where the d-c leakage current leaves the underground structures through the earth. Discussion

*Coordination between power-line and other carrier-frequency systems is not considered; these problems are usually solved by frequency separation.

of this subject is beyond the scope of this chapter, but an excellent general reference is given in Reference 2. Mention should, however, be made of the development in cathodic protection³ extensively used for preventing corrosion of pipe lines, cables, and other underground metallic circuits. In this method rectifiers of the copper-oxide or alternative forms are used to maintain the metallic circuit to be protected at a negative but low potential with respect to ground.

Structural Coordination—This problem is concerned with the layout and physical construction of power and communication circuits when located in proximity, particularly with respect to their characteristics in crossings or in constructions involving joint use of poles or overbuilt lines^{1(b),21}. The problem is also quite beyond the scope of this chapter.

The Low-Frequency Coordination and the **Noise-Frequency Coordination** problems are quite distinct. The low-frequency problem arises principally from magnetically-induced fundamental-frequency voltages at times of system faults, while the noise-frequency problem arises from induced voltages and currents of harmonic frequencies, principally for the normal operating condition. Similarly, the effects of induction are also quite different. The low-frequency problem concerns the inductive effects from the standpoint of hazard, damage to apparatus, interference with signalling, acoustic shock, etc., whereas the noise-frequency problem deals with "telephone noise" as it affects telephonic transmission and reception. For these reasons the subsequent discussion is divided into Part II, Low-Frequency Coordination, and Part III, Noise-Frequency Coordination.

II. LOW-FREQUENCY COORDINATION

In low-frequency coordination, the important induced voltages usually result from ground-return currents, although in a few cases induction from balanced currents or from voltages must be considered. In the study of low-frequency problems²², it is customary to calculate first the maximum "open-circuit" longitudinal component of induced voltage for the given exposure. To obtain this open-circuit voltage, the zero-sequence or residual current and the corresponding coupling factors must be determined. This voltage normally includes the effects of conduction through common ground connections or through mutual resistance as well as the inductive effects through mutual reactances, since, as pointed out previously, it is not convenient to separate these components. The open-circuit voltage thus calculated is next reduced to allow for shielding effects exerted by normally-grounded paralleling conductors, such as ground wires and cable sheaths or other grounded structures. In addition, for estimating some effects of induction, allowances can be made for additional shielding resulting from longitudinal currents in communication conductors, which are normally free from connection to ground but which become grounded through protector operation as a result of induction. Distribution of the induced voltage among the various protectors connected to the communication circuit is also to be determined. The final step is, of course, the estimation of the

adverse effects of the resultant voltages upon the operation and maintenance of the communication circuits and the determination, where necessary, of measures required in either or both systems to minimize the resultant effects.

7. Low-Frequency Influence Factors

In low-frequency coordination the principal problem concerning influence factors is determination of zero-sequence or ground-fault currents and their distribution among the various branches of the network for the condition that produces maximum induced voltage in the communication circuit. For a grounded-neutral power system the circuit condition giving the maximum induction in any specific parallel is usually easy to determine as it normally occurs for a fault located at the far end of the parallel from the principal power source so that the maximum ground current flows through the parallel. Consideration must also be given to the various system connections produced in the process of isolating a faulted line-section. For solidly-grounded systems it is customary to assume a single line-to-ground fault. Where the power system is ungrounded or grounded through a ground-fault neutralizer or Petersen coil, it is customary to assume a double line-to-ground fault with the faults located at opposite ends of the exposure. This condition is generally more severe from the induction standpoint than those selected for study on a solidly-grounded system. However, faults at separate locations are more likely to occur with an ungrounded system or a ground-fault neutralizer system than with a grounded system. The method of determining ground fault-current and division of current between line conductors and the earth is best accomplished by the method of symmetrical components discussed in Chap. 2 and more fully elsewhere^{4,5*}.

Neutral Impedances—Control of the influence factors, which for low-frequency induction means control of the ground current, is possible principally by choice of the location of grounding points and by the use of neutral impedance devices. The grounding point can sometimes be located so as to substantially reduce the fault currents through the exposures to magnitudes below those which would exist for other grounding locations; also, the number of faults affecting the exposure may likewise be reduced. Neutral-impedance devices provide an important and effective method for controlling low-frequency induction, particularly where the exposures are in relatively close proximity to a grounding point. The use of neutral-impedance has many effects on power-system operation as discussed in Chap. 19. Introduction of neutral-impedance devices may increase the difficulty of prompt relaying of faults, and may require relay changes. In the low-frequency coordination, the factor of greatest importance is *positive* fault disconnection. Next in importance are the magnitude of current and the speed of fault clearing. When neutral-impedance devices are used to limit ground currents, the several conditions arising in the various steps of fault clearing must be considered. Frequently the introduction of neutral impedance at one point results under fault conditions in lower drop in the voltages at remote

points with the result that increased ground currents are caused to flow through a parallel, either initially or during some stage of the fault-isolating operation. For such cases the resultant induction may not be reduced materially. Thus, effective current limitation may require treatment of many or all grounding points on the system.

For single line-to-ground faults, the ground-fault neutralizer limits the ground currents to negligible magnitudes near the fault, but near the neutralizer the currents nearly equal the neutralizer current. At present it is not practical to relay promptly a system with a ground-fault neutralizer because with such a system there is no suitable quantity related definitely to the location of the fault. If the fault persists, it is generally considered necessary to convert the ground-fault neutralizer system to a solidly-grounded system. Consequently, from the standpoint of maximum magnitude of induced voltages, such a system is substantially like a solidly-grounded system and the possibility of higher induced voltages resulting from double faults, as discussed previously, should also be considered. However, with the ground-fault neutralizer, the frequency of occurrence of large induced voltages is much less than with the system solidly-grounded. In considering such systems, the expectancy of faults should be estimated taking into account the amount of "lightning-proof" construction, particularly with grounded systems. A ground fault on a ground-fault neutralizer system causes high residual voltages which, if prolonged, can produce severe noise on a closely-paralleling telephone circuit. See Secs. 8 and 14.

In calculating ground faults, it is frequently necessary to consider the effect of the fault resistance, which includes the arc resistance and the tower-footing resistance. The effect of fault resistance depends on the location of the fault. Near a large power source at a major neutral-grounding point, it has a large influence in low-voltage systems, and may be important even in higher-voltage systems. On faults distant from a power source, its effect is less pronounced. Where towers are not interconnected by ground wires, tower footing resistance (grounding resistance of vertical ground wire in the case of wood poles) may be an important factor, as it varies through a wide range depending upon the nature of the earth where the fault occurs and the means used for grounding. Ground wires and counterpoises, which are used particularly in connection with lightning protection, reduce the effective footing resistance. The most probable value of fault resistance including tower-footing is about 20 ohms²².

8. Low-Frequency Coupling Factors

Coupling Factors for Magnetic Induction—Low-frequency (60-cycle) coupling depends upon the physical configuration of the circuits and their separation, and for earth-return circuits, also upon the resistivity of the earth.

For a single-phase *metallic-return circuit*, illustrated in Fig. 6 (a), voltage induced in a communication conductor x by magnetic induction can be expressed by the following equation:

$$V_x = +j0.2794 \left(\frac{f}{60} \right) I_a \log_{10} \frac{D_{ax}}{D_{ax}} \quad (1)$$

where V_x is the voltage induced in conductor x per mile

*Engineering Reports Nos. 4, 26 and 37 of Reference 4.

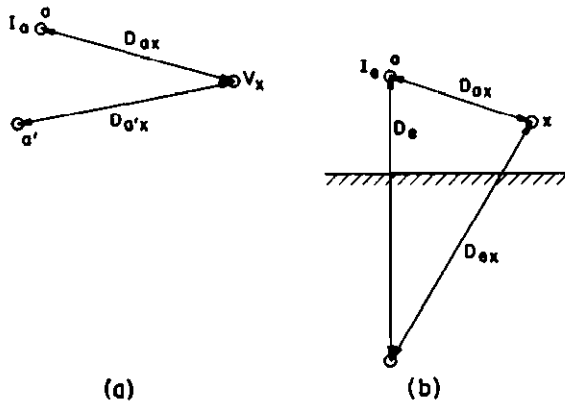

Fig. 6—Diagrams for the calculation of magnetic induction, induced voltage V_x in conductor x .

- (a) Induction from metallic-circuit current—see Eq. (1).
 (b) Induction from earth-return circuit current—see Eq. (4).

of parallel, f is the frequency in cycles per second, I_a is the current in rms amperes flowing in conductor a and returning in conductor a' , D_{ax} and $D_{a'x}$ are the distances from the conductors a and a' to x ; the distances must be expressed in the same units, preferably in feet. Similar equations can readily be written for the voltages induced in the other communication-circuit conductors.

The voltages induced in a communication conductor by magnetic induction from the currents confined to the line conductors of a three-phase power circuit can be written in an analogous manner by resolving the conductor currents into three sets of components, viz.: I , flowing out in conductor a and back in conductor b ; I_m , out in b and back in c ; I_n , out in c and back in a . The solution*, expressed in terms of phase currents, gives:

$$V_x = -j0.2794[I_a \log_{10} D_{ax} + I_b \log_{10} D_{bx} + I_c \log_{10} D_{cx}] \text{ for 60 cycles} \quad (2)$$

where V_x is the voltage induced in conductor x per mile of parallel, I_a , I_b , and I_c are the 60-cycle currents in rms amperes flowing in the conductors, a , b and c . D_{ax} , D_{bx} , and D_{cx} are the distances from conductors a , b , and c to the conductor x ; all the distances must be expressed in the same units, preferably in feet. Frequently the currents of a three-phase power circuit can be assumed to be all of positive-sequence. For this condition Eq. (2) can be simplified to the following form:

$$V_x = +0.2794I_a \left[\pm \frac{\sqrt{3}}{2} \log_{10} \frac{D_{cx}}{D_{bx}} + j \log_{10} \frac{\sqrt{D_{bx}D_{cx}}}{D_{ax}} \right] \text{ for 60 cycles} \quad (3)$$

where the notation is the same as for Eq. (2). The first term in the bracketed expression is positive for phase rotation a, b, c ; negative, if a, c, b .

Usually communication-circuit conductors and sometimes the power-circuit conductors or both are transposed in the exposure section to reduce the resultant induced voltages at noise frequencies, as discussed in Sec. 12. Transpositions are not applicable to ground-return communication circuits and are not of value for reducing longi-

*Equation (2) assumes no current in the earth and is applicable only for close exposures.

tudinal voltages in metallic circuits. Transpositions in a communication circuit reduce the metallic voltage induced by power-circuit currents irrespective of whether the return for the latter is in a metallic conductor or in the earth. Transpositions in a power circuit, however, affect the longitudinal voltage induced in the communication circuit as follows: (1) they reduce the induced voltages for all positive- or negative-sequence currents, (2) they do not affect the induced voltage for those components of zero-sequence current that return in the earth. Calculations can be made by considering separately the induced voltages, for each conductor for each section of the transposition system, and then combining them.

Earth-return circuits are the most common sources of magnetic induction in low-frequency coordination problems. In any location the distribution of current in the earth depends upon the resistivity of the earth, upon the proximity of grounding points and faults, and upon the location of the adjacent grounded conductors. The coupling factors can be estimated by assuming the return current to be concentrated in the earth at a considerable distance below the outgoing current. The voltage induced in conductor x caused by current I_a flowing in a single-phase earth-return circuit, illustrated in Fig. 6 (b), can be determined from the following approximate formula†:

$$V_x = I_a \left(\frac{f}{60} \right) \left[0.0954 + j0.2794 \log_{10} \frac{D_{ex}}{D_{ax}} \right] \quad (4)$$

where V_x is the voltage induced in conductor x per mile of parallel, f is the frequency of the power system in cycles per second, I_a is the rms value of current flowing in the aerial conductor a and returning in the earth, D_o is the equivalent depth of the return current in the earth below the outgoing conductor, D_{ax} is the separation between the power conductor a and the communication conductor x , D_{ex} is the distance between conductor x and the equivalent return for current in conductor a ; D_{ex} and D_{ax} must be expressed in the same dimensions, preferably in feet. The value of D_o is given approximately by Eq. (5).

$$D_o = 2160 \sqrt{\frac{\rho}{f}} \text{ in feet} \quad (5)$$

where f is the power-system frequency in cycles per second and ρ is the resistivity of the earth in meter-ohms. Earth resistivity is expressed in terms of the ohmic resistance between opposite faces of a cubic meter of material. The value of the earth resistivity varies through a wide range from 10 to 1000 or more meter-ohms with 100 meter-ohms perhaps most frequently encountered.

The voltage in conductor x caused by magnetic induction from the currents of a three-phase circuit for the general case of partial return in the earth, can be written in a manner corresponding to Eq. (4), with the following result:

$$V_x = 0.286 \left(\frac{f}{60} \right) I_o + j0.2794 \left(\frac{f}{60} \right) \left[I_a \log_{10} \frac{D_{ex}}{D_{ax}} + I_b \log_{10} \frac{D_{bx}}{D_{ax}} + I_c \log_{10} \frac{D_{cx}}{D_{ax}} \right] \quad (6)$$

†This formula is applicable for close exposures up to about one-half mile.

$$\left. \begin{aligned}
 K_{aa} &= \frac{\left(2 \log_e \frac{h_{bb'}}{r_b}\right)\left(2 \log_e \frac{h_{cc'}}{r_c}\right) - \left(2 \log_e \frac{h_{bc'}}{d_{bc}}\right)^2}{D} \\
 K_{bb} &= \frac{\left(2 \log_e \frac{h_{aa'}}{r_a}\right)\left(2 \log_e \frac{h_{cc'}}{r_c}\right) - \left(2 \log_e \frac{h_{ac'}}{d_{ac}}\right)^2}{D} \\
 K_{cc} &= \frac{\left(2 \log_e \frac{h_{aa'}}{r_a}\right)\left(2 \log_e \frac{h_{bb'}}{r_b}\right) - \left(2 \log_e \frac{h_{ab'}}{d_{ab}}\right)^2}{D} \\
 K_{ab} &= \frac{\left(2 \log_e \frac{h_{ub'}}{d_{ab}}\right)\left(2 \log_e \frac{h_{cc'}}{r_c}\right) - \left(2 \log_e \frac{h_{ac'}}{d_{ac}}\right)\left(2 \log_e \frac{h_{bc'}}{d_{bc}}\right)}{D} \\
 K_{ac} &= \frac{\left(2 \log_e \frac{h_{ac'}}{d_{ac}}\right)\left(2 \log_e \frac{h_{bb'}}{r_b}\right) - \left(2 \log_e \frac{h_{ab'}}{d_{ab}}\right)\left(2 \log_e \frac{h_{bc'}}{d_{bc}}\right)}{D} \\
 K_{bc} &= \frac{\left(2 \log_e \frac{h_{bc'}}{d_{bc}}\right)\left(2 \log_e \frac{h_{aa'}}{r_a}\right) - \left(2 \log_e \frac{h_{ab'}}{d_{ab}}\right)\left(2 \log_e \frac{h_{ac'}}{d_{ac}}\right)}{D} \\
 D &= \begin{cases} \left(2 \log_e \frac{h_{aa'}}{r_a}\right)\left(2 \log_e \frac{h_{bb'}}{r_b}\right)\left(2 \log_e \frac{h_{cc'}}{r_c}\right) \\ + 2\left(2 \log_e \frac{h_{ab'}}{d_{ab}}\right)\left(2 \log_e \frac{h_{ac'}}{d_{ac}}\right)\left(2 \log_e \frac{h_{bc'}}{d_{bc}}\right) \\ - \left(2 \log_e \frac{h_{ab'}}{d_{ab}}\right)^2\left(2 \log_e \frac{h_{cc'}}{r_c}\right) \\ - \left(2 \log_e \frac{h_{ac'}}{d_{ac}}\right)^2\left(2 \log_e \frac{h_{bb'}}{r_b}\right) \\ - \left(2 \log_e \frac{h_{bc'}}{d_{bc}}\right)^2\left(2 \log_e \frac{h_{aa'}}{r_a}\right) \end{cases} \quad (13)
 \end{aligned} \right\}$$

The capacitance coefficients for the usual three-phase transmission line are considerably simplified from those of Eq. (13) because the conductors are normally the same size and the geometric mean spacing usually can be used, particularly if transpositions are employed. The equivalent circuit for the three-conductor case is given in Fig. 9, the capacitances for which should include the conversion constant 0.1786 as discussed in connection with the two-conductor case.

The zero-sequence or residual voltage of an *ungrounded three-phase line* when subjected to balanced voltages can readily be determined with the aid of Eq. (13) and Fig. 9 (b). The admittances between conductors *a*, *b*, *c* and ground per mile of line are given by the following:

$$\left. \begin{aligned}
 Y_a &= 0.1786\omega(K_{aa} - K_{ab} - K_{ac}) \\
 Y_b &= 0.1786\omega(K_{bb} - K_{bc} - K_{ba}) \\
 Y_c &= 0.1786\omega(K_{cc} - K_{ca} - K_{cb})
 \end{aligned} \right\} \quad (14)$$

For a single line-to-ground fault, the voltages from the three conductors to ground consist of a positive-sequence component and a zero-sequence component in each phase. Thus, the currents flowing through the admittances Y_a , Y_b and Y_c can be expressed as follows:

$$\left. \begin{aligned}
 I_a &= (E_0 + E_1)Y_a \\
 I_b &= (E_0 + a^2E_1)Y_b \\
 I_c &= (E_0 + aE_1)Y_c
 \end{aligned} \right\} \quad (15)$$

Since the three-phase system is assumed to be ungrounded,

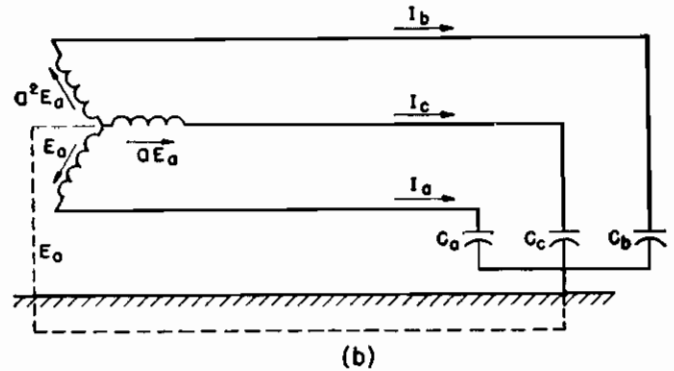
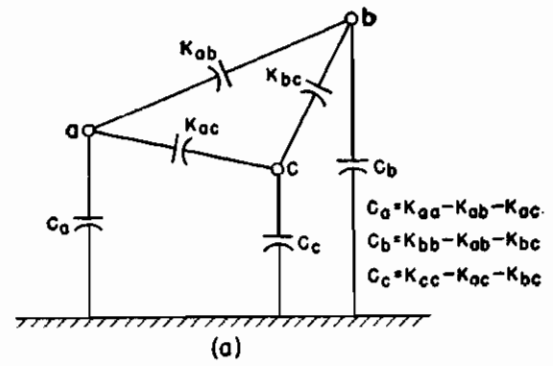

Fig. 9—Electric coupling between three parallel conductors.
 (a) Equivalent capacitance diagram.
 (b) Equivalent circuit for determining zero-sequence voltage of ungrounded three-phase system.

the sum of the three phase-currents is zero. This permits the determination of the ratio of zero- to positive-sequence voltages with result as follows:

$$\frac{E_0}{E_1} = -\frac{Y_a + aY_b + a^2Y_c}{Y_a + Y_b + Y_c} \quad (16)$$

The ratio of the residual voltage to the line-to-neutral or positive-sequence voltage is three times that given by Eq. (16).

Voltages caused by electric induction from a single power conductor with a potential to ground can be obtained from the equivalent network of Fig. 8 (b) with result as follows:

$$\frac{V_b}{V_a} = \frac{K_{ab}}{K_{bb}} = \frac{\log_{10} \frac{h_{ab'}}{d_{ab}}}{\log_{10} \frac{h_{aa'}}{r_a}} \quad (17)$$

The capacitance coefficients for the *four-conductor case* can be obtained in a similar manner with the aid of the equivalent network shown in Fig. 10. This solution can be used to obtain the voltage electrically induced on conductor *x* by a three-phase circuit. If the power system is grounded, the potentials of conductors *a*, *b* and *c* with respect to ground are known and the potential of conductor *x* to ground is calculated by considering only the capacitances K_{ax} , K_{bx} , K_{cx} and $(K_{xx} - K_{ax} - K_{bx} - K_{cx})$. If the power circuit is ungrounded, then it is necessary to determine the zero-sequence voltage of the system to ground. If the conductor *x* is ungrounded or if it is sufficiently re-

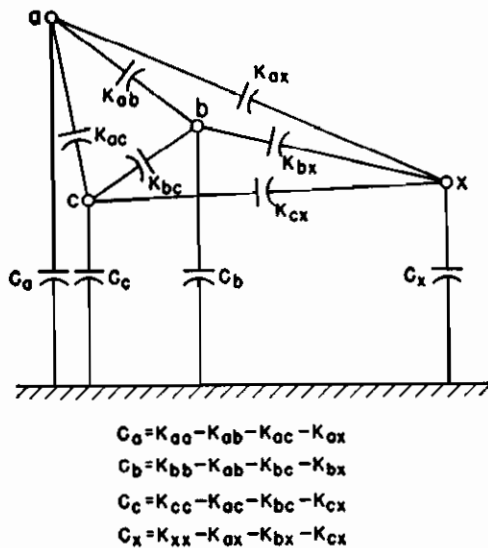

Fig. 10—Electric coupling between four parallel conductors—equivalent capacitance diagram.

mote, then the potential of the system of power conductors with respect to ground is determined by neglecting the conductor *x*. This makes possible the use of the method outlined in connection with Fig. 9. When the potentials of the conductors *a*, *b*, and *c* with respect to ground have been determined, then the potential of conductor *x* can be obtained in the usual way.

Shielding Conductors—Special grounded conductors, which are used for reducing the voltages from electric or magnetic induction on communication circuits, are called shielding conductors. Shielding action may also result from grounded conductors that are a normal part of either power or communication circuits.

Shielding against electric induction is provided by a conductor grounded at one point. The method just described for determining the coupling factors for electric induction can also be used for determining the effectiveness of shielding conductors. A grounded cable sheath provides practically complete protection against electric induction. Shielding against magnetic induction is provided by grounding the shielding conductor at the ends alone or at intermediate points in addition. The ground connections should be of low resistance so as to facilitate the flow of current through the shielding-conductor earth-circuit. The current flowing in the shielding conductor can readily be calculated by the method previously described or as discussed more fully in Chap. 2, in Reference 5 or in Engineering Report No. 48 of Reference 4. The reduction in the voltage induced in the circuit to be protected can then be calculated by considering the voltages that result from the currents flowing through the shielding conductors, using the method discussed in connection with Eq. (4) and Figs. 6 and 7.

The effectiveness of shielding action varies widely, depending upon the physical dimensions of the shielding conductor, the resistance of the conductor and earth connections, and the coupling to the circuit to be protected. A steel ground wire may carry about ten percent of the zero-sequence current in the power circuit. Two 4/0 copper ground wires may increase the shielding action so that 40

percent of the zero-sequence current will return in the ground wires. The shielding at 60 cycles of a full-sized lead-sheath telephone cable is about 50 percent and if the sheath is wrapped with magnetic tape armor (two 40-mil tapes on the larger sizes) the shielding is increased to 80 or 90 percent depending upon the magnitude of induction, assuming that there is good contact with the earth. The shielding given by power cables depends upon construction and varies from 40 to 70 percent. Shielding conductors on either the power circuit or on the communication circuit can provide a remedial measure of value.

9. Low-Frequency Susceptiveness Factors

The effects of low-frequency induction on a communication circuit depend upon its magnitude and duration, and upon the frequency of occurrence of the abnormal condition. Some of these effects can occur at voltages below

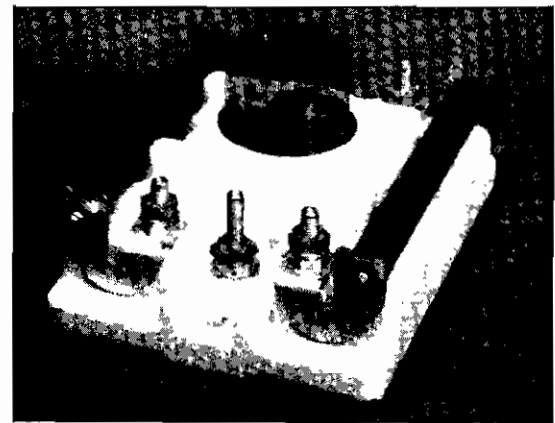

(a)

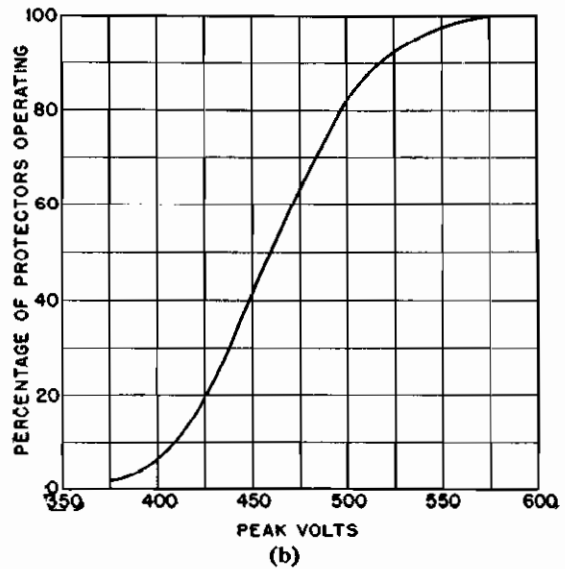

(b)

Fig. 11—Features of standard Bell System telephone protector.

- (a) General appearance of subscriber protector, the No. 98A protector, with two fuses and two sets of protective gaps. The protector blocks (Nos. 26 and 30) within the cap are shown by phantom view.
- (b) Typical breakdown characteristics (Nos. 26 and 30 blocks).

those producing operation of protective equipment. Such effects include false signalling and relay chattering on telephone circuits, distortion of telegraph signals, and false relaying on supervisory control circuits. The more serious effects from low-frequency induction are, however, usually associated with voltages of sufficient magnitude to operate protectors.

Standard Telephone-Circuit Protection—Telephone circuits subjected to the possibilities of extraneous voltages above about 250 volts are equipped with protectors. At subscriber premises these protectors usually consist of seven-ampere fuses and carbon-block discharge gaps with a spacing of three mils. The general appearance of this station protector is shown in Fig. 11, together with a breakdown characteristic of the discharge gap. This curve, obtained under certain conditions in laboratory tests on new blocks, should not be taken as generally representative of behavior under field conditions. Similar protector blocks assembled in a group mounting, with facilities for terminating a large number of cable pairs, are used in central offices. Protectors located at the junction of open-wire and cable are usually provided with similar carbon blocks with six-mil spacing. Where open-wire telephone lines are located in joint-use construction with higher-voltage distribution lines, special protectors capable of withstanding a high discharge current are sometimes placed on the telephone circuits, generally at or near points from which customers are served.

The operation of telephone protector blocks produces several important effects. In the first place the protector blocks do not break down in an identical manner, with the result that unsymmetrical voltages are produced, which cause equalizing currents to flow through the telephone receivers. The high currents flowing through the receiver under such conditions can produce acoustic shock. In considering this type of interference it is necessary to include the adverse psychological reactions to the threat of such action. If the current through the protector blocks is large or prolonged, they may become grounded, rendering the circuit inoperative. The standard Bell System telephone protector blocks consist of two carbon electrodes, one of which is mounted as an insert in a porcelain block so that if the insert is heated as by passage of current, it is released and makes a permanent ground. After protector blocks are grounded, service cannot be restored until they have been replaced by maintenance forces.

The longitudinal-component of voltage impressed on a communication circuit is distributed around the circuit in accordance with the circuit constants; ordinarily the voltages divide across the two ends of a telephone circuit substantially in proportion to the impedances in the two directions from the center of the exposure. Frequently the exposure is not symmetrical with the circuit so that the large part of the total induced voltage appears across one of the protectors. For this reason the total voltage required to produce protector breakdown varies through quite a range and normally is taken only slightly above the breakdown voltage of a single protector.

Cables—The use of cables instead of open-wire construction is an important coordination measure because of the shielding action provided by sheaths, as discussed pre-

viously. The greater cost of cable construction, however, limits the usefulness of this measure to situations where many circuits are involved or where severe exposures are encountered for circuits of fixed location. Reduction of induced voltages by putting circuits inside a cable sheath is generally practicable only where a new communication line is to be built or an old line replaced. The extensive use of cables for both communication and distribution circuits in urban and suburban areas has, however, greatly simplified the coordination problem in these areas of close exposure. Special cables are made with steel-tape armor, and with grounded shielding conductors located inside of the cable sheath. Such cables greatly increase the effectiveness of shielding action, and reduction factors as great as 95 percent are obtainable. In addition, special cables have been built with higher than normal insulation, particularly for use in locations along the right-of-way of a-c railways. Such cables are normally tested at 1000 volts rms between conductors and 3500 volts rms to ground for 20 seconds. When highly-insulated cables are used, it may be necessary to install insulating transformers between the line and terminal equipment.

Special Types of Protective Measures*—Three classes of special measures of value against low-frequency induction are:

1. Special measures to avoid adverse effects of induction without changing insulation or reducing induced voltages.
2. Reduction of induced voltages.
3. Increased circuit insulation with proportionate increase in protector breakdown voltage.

Relay Protector—A relay protector for a pair of wires consists of a set of protectors, usually of the carbon-block type, connected to ground or across the telephone circuit, together with a coil connected in series with the discharge path, and with relay contacts for short-circuiting the protectors, capable of carrying heavy currents for short periods, e.g., 100 amperes for $2\frac{1}{2}$ seconds. The relay operates in one cycle or less to shunt the normal protectors, which are by this means prevented from becoming grounded. After the abnormal voltage condition has disappeared, the relay returns to its normal position and the circuit again becomes operative. This device is used for avoiding maintenance trouble and, except during the fault, interruption of service on telephone and supervisory circuits. The relay protector also is available in a form suitable for application to all the wires of a line. The device is of value for supervisory control if the transmission of signals during the abnormal condition is not essential. The relay protector has the advantage over the vacuum or low-pressure gas-filled protector of having a lower breakdown characteristic for the majority of applications, and for this reason is the more commonly used.

Acoustic-Shock Reducer—The acoustic-shock reducer is a device applied to telephone circuits to minimize the acoustic shock resulting from unsymmetrical discharge of protectors that cause high currents in the telephone re-

*Protection of ground-return signal circuits, particularly telegraph circuits against fundamental-frequency induction from power circuits or a-c railway circuits is discussed at considerable length in Reference 23.

ceiver. The most widely used acoustic-shock reducer consists of two oppositely-poled groups of copper-oxide rectifiers, the combination having high resistance to the low voltages which are used in ordinary communication and having low resistance to the relatively high metallic-circuit voltages produced when telephone protectors are operated, thus by-passing the telephone receiver. The acoustic shock reducer does not, of course, avoid the other disadvantages of protector operation.

Special Protectors—Special vacuum tube, or preferably, low-pressure gas-filled protectors, are sometimes used for protecting circuits subjected to induction that would oper-

ate ordinary protectors. The advantage of the tube-type protector is that wider spacing can be obtained, which minimizes the tendency for protectors to ground. The discharge voltage of the tube protector usually is somewhat higher than that of the standard telephone gap and for that reason is preferably used with somewhat higher than normal insulation.

Drainage Schemes—By providing a drainage path to ground, the resultant voltage on a communication circuit can be reduced sufficiently to avoid the necessity of relief by protector operation. Fig. 12 (a) shows a simple drainage scheme with a balance coil for a telephone or audio-frequency signaling system. Fig. 12 (b) shows a resistance drainage scheme for a d-c signaling system. In this arrangement the voltage impressed on the terminal equipment is reduced by the drop consumed in the line resistances R' caused by the drainage currents flowing through resistors R . This scheme is used in supervisory-control circuits of limited length or limited inductance. Fig. 12 (c) shows a resonant-drainage scheme with elements L and C tuned for the fundamental frequency of the power system, so as to provide low-impedance paths for the induced voltages. The resonant drainage is relatively more effective for steady-state or slow transients than for the abrupt transients. Probably the most successful scheme for protection of supervisory control, shown in Fig. 12 (d), utilizes longitudinal choke coils. Each coil is wound to have negligible inductance in the metallic circuit but high inductance in the longitudinal circuit which is completed through capacitances C . In a typical installation the coils have longitudinal-circuit impedances of 40,000 ohms and the shunt capacitors are 0.25 microfarad. With this scheme, the induced voltage is largely removed from the terminals although left on the line. Hence, this scheme is applicable only when the line insulation can withstand the maximum induced voltage or where other means are used in combination to prevent the adverse effects from induction in the lines. The scheme is sometimes described as a self-neutralizing transformer scheme because the resultant voltage distribution is close to that of the neutralizing-transformer scheme discussed in the next paragraph and the function of the neutralizing wire is provided by the circuit itself.

Neutralizing-Transformer—One of the oldest and most successful schemes for protecting communication circuits against induction is the neutralizing-transformer scheme. In this scheme, shown schematically in Fig. 13, a neutralizing-wire is placed close to the wires of the circuit to be protected so as to be subjected to the same induced voltages. Transformers are connected in the neutralizing-wire circuit and in the circuit to be protected, with the windings so arranged that the voltage produced in the communication circuit by the transformer action opposes and effectively "neutralizes" the voltage directly induced in the communication circuit. The voltage induced in the communication circuit is divided among the several neutralizing transformers. This scheme requires an additional wire and ground connection, the total resistance of which must be low in comparison with the impedance of the ground-return circuit. The neutralizing-transformer scheme was initially used for the protection of telegraph circuits exposed to induction from a-c railway circuits under normal

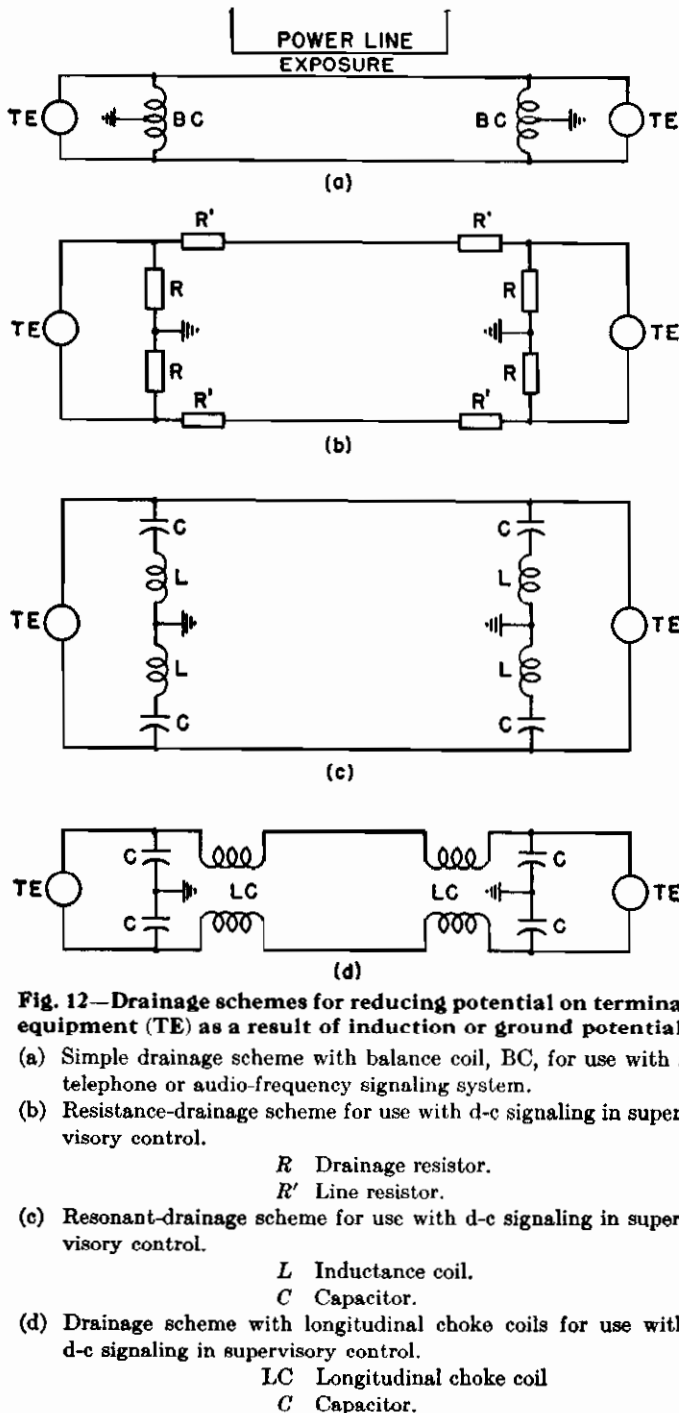

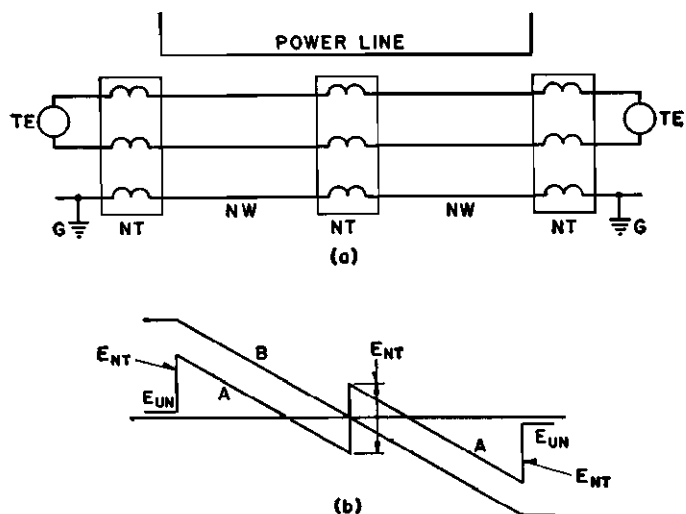

Fig. 13—Neutralizing transformer scheme.

- (a) Schematic diagram.
 - TE Telephone terminal equipment.
 - NT Neutralizing transformer.
 - NW Neutralizing wire, subject to same induction as the telephone wires.
 - G Grounds of low resistance.
- (b) Voltage distribution along telephone line.
 - A With neutralizing transformer.
 - B Without neutralizing transformer.
 - E_{NT} Voltage induced by neutralizing transformer.
 - E_{UN} Unneutralized voltage on terminal equipment.

operation. In recent years it has been used on telephone circuits, particularly to provide protection against rise in ground potential that would otherwise appear in leased circuits used for power-company communication^{23, 24} or for pilot-wire relay protection. If only rise in ground potential is important, that is, if ordinary magnetic induction is negligible, it is necessary merely to connect the neutralizing-wire winding of the neutralizing transformer between the station ground and a remote ground, i.e., a ground out-

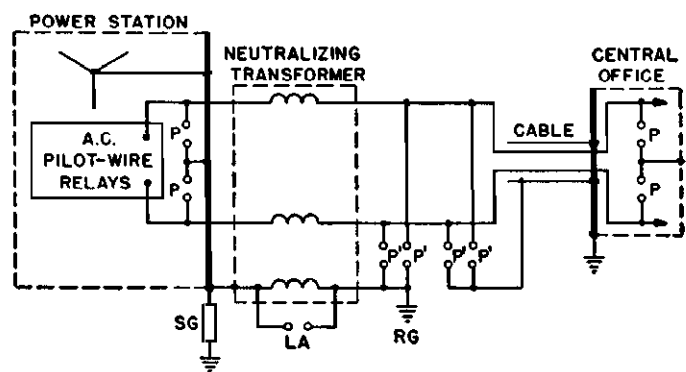

Fig. 14—Schematic diagram of neutralizing-transformer scheme for the protection against rise in station ground potential in leased circuits used for pilot-wire relaying.

- LA Lightning arrester—distribution type.
- P Telephone protector (No. 26 and No. 27 blocks).
- P' Telephone protector (No. 26 and No. 30 blocks).
- SG Station ground.
- RG Remote ground, located beyond influence of station ground.

side of the influence of the station ground. Ordinarily this means a relatively short length of neutralizing-wire. The principal features of this arrangement are shown in Fig. 14. The suitability of a remote ground can be checked by circulating fault current through the station ground and determining the rise of potential of that ground with respect to an unquestionably remote ground, such as the central office. The neutralizing transformer is exposed to lightning voltages that may come from the aerial communication circuit or as a result of heavy discharge through the power-station ground. The insulation of neutralizing transformers is, of course, not high enough to avoid the possibility of breakdown against these lightning voltages. If a plain protective gap were connected across it, there would be the possibility of dynamic-current flow across the gap and into the remote ground and across the protectors P' into the central-office ground which would result in grounded protectors. This can be avoided by the use of a valve-type arrester, such as the available distribution-type power arresters. The voltage class of the lightning arrester should be selected so that its cutoff voltage will be above the maximum expected difference in 60-cycle voltage between the station ground and the remote ground. The neutralizing transformer permits d-c signaling and routine circuit testing in accordance with Bell System practice.

Insulating Transformers—The effects of low-frequency induction can be avoided by increasing the insulation of the communication circuit and by using insulating transformers between lines and terminal apparatus. Such an arrangement is shown in Fig. 15 and is normally used for power-line telephone systems or for exposed lines that are

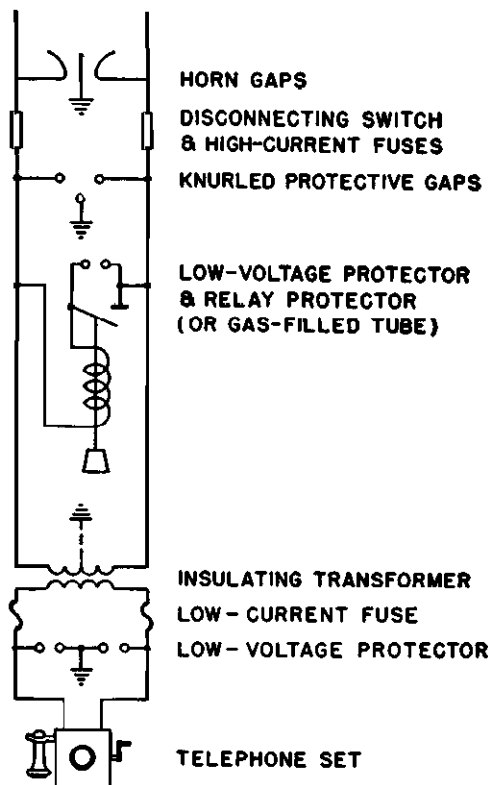

Fig. 15—Protective scheme for exposed or power-line telephone systems.

connected to commercial telephone systems. The arrangement shows the insulating transformer between the line and the local apparatus, together with low-voltage knurled-type protective gaps and with disconnecting switch and high-current fuses. The combination of the horn gap and the high-voltage fuse has been found by experience to provide the best protection. To avoid a burnout of the insulating transformer in case gaps operate on one side of the line only, a low-voltage protector is connected directly across the metallic circuit. To minimize the possibility of bridging this protector a relay-type protector is connected in parallel with it as shown in Fig. 15, or a low-pressure gas-filled protector tube can be used. On some circuits it is necessary to minimize the effect of electric induction under normal operating conditions, by draining the line so that the necessary charging currents can flow. It is possible to use the midpoint of some of these insulating transformers for a drainage connection. For protection against magnetic induction, it is sometimes feasible to insert several insulating transformers distributed along the circuit to be protected.

Pilot-wire relaying channels can be protected against the effect of ground potential as shown in Fig. 16, which

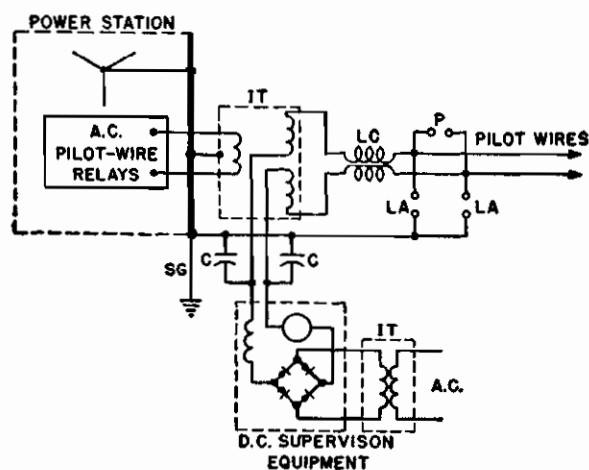

Fig. 16—Schematic diagram illustrating use of insulating transformers for protecting pilot-wire relaying circuit with superposed d-c channel for supervision.

- | | | |
|----|---|-------------------|
| IT | Insulating transformers. | } See Fig. 12 (d) |
| LC | Special coils. | |
| C | Capacitors for grounding. | |
| LA | Lightning arresters—distribution type. | |
| P | Protectors, preferably gas-filled type. | |
| SG | Station ground. | |

includes provision for d-c supervision. In this arrangement if the longitudinal choke coils are not used, the insulating transformers absorb the difference of potential between the station ground and the remote ground. It also has the particular advantage in connection with pilot-wire relaying channels of providing a "turn ratio" device needed to avoid producing high line drop where standard five-ampere secondary current transformers are used for relaying purposes. The conditions in regard to the need for the lightning arrester across the transformer are the same as for the circuit of Fig. 14. The transformer in this case is of simple

design, since it is not required to meet the balance requirements for use on telephone circuits, but merely provides the turn ratio and requisite insulation strength between primary and secondary windings. When a superposed d-c signaling channel is to be used over a circuit equipped with insulating transformers, the line winding is arranged in two sections, the mid-points of which are connected to ground through suitable capacitors as shown in Fig. 16. These mid-points can be used as line connection for the d-c signaling circuit, the source for which can conveniently be provided by copper-oxide rectifiers and suitable insulating transformers. To provide protection against higher induction or ground potential, special longitudinal choke coils LC are added to the circuit as shown in Fig. 16. These coils are arranged to be non-inductive in the metallic circuit but to have high inductance for the longitudinal circuit, and to have considerable dielectric strength for that path. This general arrangement provides supervision features for checking the integrity of a pilot-wire channel against open circuits, short circuits, or grounds. If supervision features are not required, the mid-point connections of the insulating transformer are omitted and the line-side winding arranged in a single section. This results in simple connections for the pilot-wire relaying circuit.

III. NOISE-FREQUENCY COORDINATION

A telephone circuit traversing electric and magnetic fields will, in general, produce extraneous currents in all connected telephone receivers. These extraneous currents interfere with telephonic transmission if they are in the audio- or noise-frequency range and of appreciable magnitude compared with normal voice currents.

Noise-frequency coordination problems involve the same basic factors as the low-frequency problems, namely, influence characteristics of the power circuit, susceptiveness of the communication circuit, and coupling between the circuits. These factors are, however, limited to the characteristics in the audio- or noise-frequency range and are, therefore, different from those encountered in low-frequency coordination. In general, the important frequencies in the noise-frequency problem are the incidental or harmonic frequencies of power-system operation. These harmonics are produced by reluctance changes due to poles and slots in rotating machines, by saturation in magnetic circuits, and by cyclic circuit changes in rectifiers and commutating machines. In the present state of the art these characteristics of electrical apparatus cannot be avoided, and any large improvement would require radical changes in apparatus design that would greatly increase the cost and decrease serviceability. It is, however, to the interest of both power and communication companies to control the harmonics to the greatest practical extent.

The investigation of a noise-frequency coordination problem requires the determination of (1) the noise-frequency or harmonic voltages and currents in the power system for each section involved in an inductive exposure, (2) the coupling factors between the power and communication circuits, and (3) the harmonic currents produced in the telephone receiver, or the telephone noise. The final step involves determination of whether the noise conditions are

satisfactory, and if unsatisfactory the selection of the appropriate remedial measures. The various factors in this problem are first considered, after which a method is given for estimating the resultant noise in the telephone circuit.

10. Frequency-Weighting Curves

The severity of an exposure in noise-frequency coordination is difficult to define because of the many harmonic frequencies that may be present. It becomes desirable, therefore, to find a single factor, representing the effects of all the frequencies present, by means of which the severity of an exposure may be appraised. This is accomplished by the use of frequency-weighting curves as shown in Fig. 17.

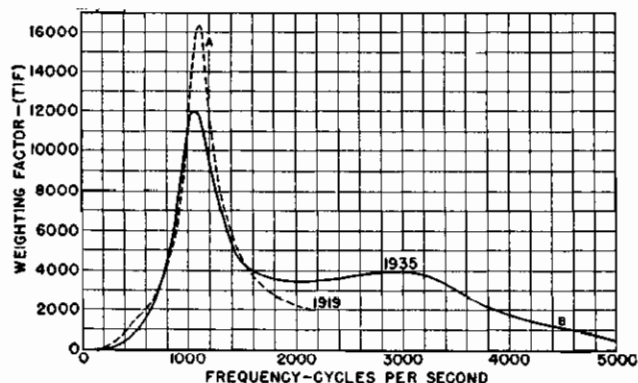

Fig. 17—T.I.F. weighting curves.

- A—Telephone interference factor—based on 1919 frequency-weighting curve.
 B—Telephone influence factor—based on 1935 frequency-weighting curve.

In the determination of such curves consideration is given to the following factors:

1. Coupling between power and telephone circuits.
2. Frequency-response characteristic of the telephone circuit, particularly the telephone receiver.
3. Law of combination for effects of several frequencies.
4. Characteristics of the human ear in regard to its perception of sounds.
5. The effect of telephonic noise in adversely affecting reception because of unintelligibility or annoyance.

To obtain the frequency-weighting curves^{8,9}, extensive "judgment" and "articulation" tests were made on telephone circuits subjected to single-frequency voltages of variable magnitudes. Judgment tests involve comparisons in the presence of speech of the relative interfering effects of the disturbing frequency to that produced by a reference noise in the receiver. Articulation tests involve the comparison of the accuracy in receiving meaningless monosyllables in the presence of variable amounts of the disturbing frequency. When currents of several frequencies are present in the telephone receiver, the overall effect corresponds to a complicated combination of the components. However, experience shows that satisfactory results can be obtained by combining the weighted components for the several frequencies according to the square root of the sum of the squares. These considerations provide the basis

for methods of estimating or measuring the total telephone-circuit noise, discussed in Sec. 14. Thus, starting with the harmonics in the voltages and currents of a power system and using coupling factors and the frequency-weighting curve applicable to the telephone circuit, it is possible to estimate the overall effect from the coordination standpoint. However, for many purposes it is more convenient to obtain a single factor applicable to the harmonics on a power system. To do this it is necessary to modify the frequency-weighting curves applicable to the telephone circuit by factors which take into account the coupling between power and telephone circuits. Experience shows that a factor directly proportional to frequency gives satisfactory results for both current and voltage harmonics. This leads to frequency-weighting curves applicable to harmonics on power systems. These are called T. I. F. curves, where T. I. F. means telephone interference factor or telephone influence factor. Improvements in the telephone receivers over a period of years require different frequency-weighting curves as discussed in the following paragraph.

Telephone Interference Factor, Telephone Influence Factor, and T.I.F. Curves—The original or 1919 frequency-weighting curve applicable to power-system harmonics is given in Curve A of Fig. 17, and the term was called Telephone Interference Factor. In 1935 a new frequency-weighting curve, as shown in Curve B of Fig. 17, was adopted and the term was changed to Telephone Influence Factor as being more descriptive of the actual quantity. The new type of hand set put into production by the Bell System in 1938 makes imminent further changes in the frequency-weighting curves. Originally it

TABLE 1—T.I.F. WEIGHTINGS OF VARIOUS SINGLE FREQUENCIES

Frequency	1919 T.I.F.	1935 T.I.F.
60	8.8	1
180	112	15
300	440	205
360	770	370
420	1 100	590
540	1 770	1 250
660	2 540	2 250
720	3 100	2 990
780	3 870	4 080
900	6 260	7 270
1 020	11 700	11 600
1 080	16 000	11 980
1 140	16 100	11 100
1 260	9 350	7 920
1 380	6 100	5 470
1 440	5 250	4 740
1 500	4 530	4 400
1 620	3 600	3 900
1 740	3 020	3 660
1 800	2 750	3 580
1 860	2 600	3 570
1 980	2 280	3 500
2 100	2 000	3 500
2 500	3 680
3 000	3 940
5 000	480

was intended that the 1935 T.I.F. curve and the term Telephone Influence Factor should replace the earlier forms. However, the transition requires time and has not been made throughout the industry and it appears that this change will not be made until after new curves are adopted. As a consequence, both the 1919 and 1935 T.I.F. curves and the corresponding terms are in use at present and their definitions are as follows:

The *telephone interference factor* of a wave is the ratio of the square root of the sum of the squares of the weighted rms values of certain groups or of all sine-wave components, including in alternating waves both the fundamental and the harmonics to the rms value of wave. The weightings to be applied to the individual components of different frequencies are as given in Curve A of Fig. 17 and Table 1.

The term *telephone influence factor* has the same definition as telephone interference factor except that the frequency weightings are obtained from Curve B of Fig. 17 and Table 1.

These T.I.F. factors for apparatus are of two kinds, balanced and residual component. The definitions of these factors for a synchronous machine are as follows:

The balanced telephone interference factor (or balanced telephone influence factor) of a three-phase synchronous machine is the ratio of the square root of the sum of the squares of weighted rms values of the fundamental and the non-triple series of harmonics to the rms value of the normal no-load voltage wave.

The residual-component telephone interference factor (or residual component telephone influence factor) of a three-phase synchronous machine is the ratio of the square root of the sum of the squares of the weighted values of one-third of the rms fundamental and harmonic residual voltages to the rms value of the normal voltage from line to neutral*.

Balanced T.I.F. is obtained from the positive- and negative-sequence voltages and currents, including both fundamental and harmonics, while the residual component† T.I.F. is obtained from the zero-sequence voltages and currents, including fundamental and harmonics, which, from a practical standpoint, are limited to those of the triple-harmonic series. Balanced and residual T.I.F. terms are also used in connection with systems under load conditions.

Meters are available for measuring the telephone interference factor and the telephone influence factor of both voltage and current waves. In the case of voltage T.I.F. measurements, the reading is the ratio of the current in the metering element in micro-amperes to the rms value of voltage being measured. In the case of current T.I.F. measurements, the drop across a one millihenry inductance in a series relation with the current being measured, is impressed on the meter, and the reading is the ratio of the current in the metering element in micro-amperes to the rms value of the current wave. Usually current and potential transformers are necessary to reduce the voltages and currents to magnitudes suitable for T.I.F. meters. In measurement of balanced T.I.F. for voltage on a machine or for voltage or current on a system, the

*See also Sec. 11, Influence Factors.

†Residual-component quantities are equal to the zero-sequence components, while residual quantities are three times the zero-sequence components.

line-to-line voltage or line currents with zero-sequence components removed are used. For the measurement of residual-component voltage T.I.F. of a machine, the machine may be connected in "open delta" and a potential transformer placed between the meter and the machine. An alternative method applicable to both a machine or system is to connect the primary windings of three potential transformers from line-to-neutral terminals of the machine or system and to connect the secondary windings in opened delta across the T.I.F. meter. When potential transformers are used, they will introduce a small error resulting from the triple harmonics produced by the transformers themselves. This error is, however, unimportant, except where very low values of residual-component T.I.F. are being measured. Residual-current T.I.F. of a system may be obtained by using the sum of the three phase currents to energize the one millihenry coil across which the T.I.F. meter is connected. The terms $KV \cdot T$ and $I \cdot T$ are frequently used in connection with system quantities and give the total weighted factors for voltages and currents respectively, both balanced and residual. In these terms T represents voltage or current T.I.F., KV the rms line-to-line, or residual voltage in kilovolts, and I the rms line current (with zero-sequence component removed), or the residual current in amperes.

11. Noise-Frequency Influence Factors

On commercial power systems of either the three-phase or the single-phase midpoint-grounded types, two kinds of circuits require consideration, namely, (1) the circuits whose paths are limited to the line conductors and (2) the circuits whose paths involve ground. Telephone engineers are accustomed to use the terms *balanced voltages* or *currents* for those which are confined to the line conductors and the term *residual voltages* or *currents* to those which are associated with ground. Power engineers generally use symmetrical components and thus will recognize that the balanced voltages or currents are those of positive- or negative-sequence and that the residual voltages or currents correspond to the sum of three phase quantities or to three times the zero-sequence quantities. Consideration must be given separately to these two types of circuits because the coupling factors between the power circuits as a whole and the communication circuit are much greater for residual or zero-sequence than for the balanced or positive- and negative-sequence; the ratio of these coupling factors, which may be as high as 50, depends upon power-circuit configuration and the separation between power and telephone circuits.

Sequence of Harmonics—Harmonics of symmetrical three-phase systems analyzed by symmetrical components⁵, are of definite sequence. In a symmetrical system the even harmonics are absent and the remaining harmonics are divided between the sequences as shown in the accompanying Table 2.

Thus, positive-sequence harmonics are all of the order $(6n+1)$ where n is any integer; the negative sequence, $(6n-1)$ and the zero sequence, $(6n-3)$. Triple harmonics require separate consideration from the positive- or negative-sequence harmonics because the former are of zero sequence and flow in a different path. In a symmetrical

TABLE 2—SEQUENCE OF HARMONICS IN THREE-PHASE SYSTEMS

Harmonic	Sequence	Harmonic	Sequence
1	Positive	19	Positive
3	Zero	21	Zero
5	Negative	23	Negative
7	Positive	25	Positive
9	Zero	27	Zero
11	Negative	29	Negative
13	Positive	31	Positive
15	Zero	etc.	
17	Negative		

system the line-to-neutral voltages contain all the harmonics present in the line-to-line voltage and in addition contain the zero-sequence harmonics.

Balance of a Power System—If, under normal operating conditions, a power system is symmetrical and if voltages of positive-sequence only are generated, then only currents of positive-sequence can flow. However, if the circuit is unbalanced, the flow of positive-sequence current, for example, through unbalanced series impedances, produces unbalanced voltages that include a zero-sequence component and produce zero-sequence currents, the importance of which from the induction standpoint may be many times that of the original balanced currents. This difference results from the greater coupling inherent in the residual or zero-sequence paths. Frequently, it is desirable to transpose the system in order to balance it.

Wave-Shape Characteristics of Power Apparatus

—Power systems normally operate at a fundamental frequency of 60 cycles, but it is necessary at times to consider 25 and 50-cycle a-c circuits and d-c circuits. The wave-shape characteristics of power systems are influenced principally by the harmonics generated in synchronous machines and converting apparatus and by exciting currents in transformers. In a few cases it has been necessary to consider other types of apparatus that produce harmonics.

Synchronous Machines—The important sources of harmonics in most power systems are synchronous machines, particularly generators. These, including condensers, frequency-changer sets, converters, and motors for industrial drive, have similar wave-shape characteristics. Except in a few applications, the smaller synchronous machines and the synchronous motors for industrial plants are usually unimportant unless larger than say 1000 kva.

The principal sources of harmonics in a synchronous machine are:

1. The field form, particularly with salient-pole construction.
2. The variation in reluctance caused by slots.
3. Saturation in main circuits and leakage paths.
4. Damper windings, which frequently are unsymmetrically spaced.

The most important of the possible methods of controlling the harmonics are:

1. Large air gap.
2. Shaping of pole pieces.
3. Partially-closed slots.

4. Skewing of poles or slots.
5. Number of slots per phase per pole.
6. Chording of the windings.
7. Fractional-slot windings.

Often many of these controls are impractical since they would greatly increase costs. Ordinary closed slots are generally impractical because form-wound coils cannot be used. Skewing of poles or slots is an effective measure but frequently increases losses and introduces mechanical problems in construction and interferes with the rigidity of the support, which is usually not uniform throughout the length of the pole or slot. The more commonly useful factors include:

1. Suitable ratios of slot opening to air-gap length.
2. The avoidance of certain numbers of slots per pole per phase giving slot frequencies in the vicinity of 1100 cycles.
3. Chorded and fractional-slot windings.

By varying the pitch of chorded windings it is possible to eliminate particular harmonics, but this is usually accompanied by an increase in some other harmonic. Consequently, chording is a factor of limited usefulness. One of the most practical controls for slot harmonics is fractional-slot windings. While many combinations are possible, a frequent arrangement is an odd number of slots per pair of poles. This has the effect of keeping the reluctance constant since a change under one pole is compensated by an equal and opposite change under the adjacent pole. However, such windings do interfere with the use of standard parts and generally require greater development for a line of machines than normal.

The most important harmonics of a synchronous machine result from the slot frequencies, and their values are given by:

$$F_s = S(rps) \pm f \quad (18)$$

$$= (2N \pm 1)f \quad (19)$$

where F_s —slot frequencies

S —total number of armature slots

rps —machine speed in revolutions per second

f —fundamental frequency

N —number of slots per pole

The frequency given by the first terms corresponds to the pulsation of reluctance in the magnetic circuit. Because of the effect of rotation of the rotor, the harmonics appearing in the armature circuit are increased and decreased by the fundamental. Thus, if the slot frequency corresponds to the 18th harmonic the frequencies appearing in the output circuit of a synchronous generator are the 17th and 19th harmonics of the fundamental. The slot frequencies always occur in pairs but their magnitudes are frequently quite different, the cause for which has not been fully investigated. Double-frequency pulsations are produced (1) by saturation in the magnetic circuit, particularly in the teeth, and (2) by reflection from currents induced in rotor bars by the slot ripple. Additional frequencies may be produced by damper windings, which usually are not uniformly distributed within the pole or interpolar space. With non-uniform arrangements it is

difficult to estimate the magnitude and equivalent frequency of these harmonics. Consequently, these effects are estimated principally from tests on similar machines.

The foregoing discussion applies to positive- and negative-sequence harmonics and to zero-sequence harmonics as well. However, the zero-sequence or triple harmonics require special attention because, as pointed out previously, they are the only ones acting on the zero-sequence path in a symmetrical system. Triple harmonics in a synchronous machine can be controlled by altering the field form and particularly by using a two-thirds pitch winding. Theoretically, these measures should be sufficient to eliminate the triple harmonics and in practice this is substantially accomplished if a two-thirds pitch winding is used. The windings of two-pole machines are generally designed with a throw less than two-thirds pitch because of the difficulty of getting coils with longer throw through the small bores. Machines with four or more poles are generally designed with coil throws as near full pitch as possible in order to work the material in the most economical manner. To obtain the advantage of keeping the triple harmonics low, a two-thirds pitch winding is required because small departure in pitch would greatly increase the magnitude of these harmonics. A two-thirds pitch winding is, however, not desirable from the standpoint of the balanced harmonics because other windings are more advantageous for controlling the nontriple harmonics, for example, a winding of 0.833 pitch reduces the 5th, 7th, 17th and 19th harmonics by 75 percent of the full pitch value. A two-thirds pitch winding has low impedance to triple harmonics and thus may constitute a contributing factor in the coordination problem for triple harmonics produced in other parts of the system. The two-thirds pitch windings will, in general, increase the cost of machines, but this may be justified in particular cases where severe exposures involving zero-sequence coupling are anticipated.

The wave-shape requirement of synchronous machines are defined in the A.I.E.E. standards in two ways, namely, Deviation Factor and Telephone Interference Factor. The deviation factor is obtained from the magnitude-time curve of the machine no-load normal voltage wave and a sinusoidal wave of the same rms value, the two curves being adjusted so as to give the minimum maximum deviation. The A.S.A. Standards C-50 call for a maximum permissible deviation of 10 percent. However, wave-shape deviation is relatively unimportant in inductive coordination because deviation is usually controlled by the lower harmonics whereas the telephone interference factor is controlled by higher harmonics of much smaller magnitude.

The wave-shape requirements of a generator from the coordination standpoint are normally defined in terms of the no-load voltage telephone interference factor discussed previously. The standard values of voltage T.I.F. for synchronous machines adopted by N.E.M.A. are as given in Table 3. The range above 1000 kva was previously adopted by N.E.L.A.¹⁰

The foregoing levels, it is to be understood, will not avoid the possibility of interference in all cases, nevertheless, they represent the most reasonable limits at the time of their original adoption in 1932 and have given good re-

TABLE 3—TELEPHONE INTERFERENCE FACTORS (T.I.F.)
STANDARD VALUES FOR SYNCHRONOUS MACHINES

Machine Kva Range 60 Cycles	Balanced T.I.F. Line-to-Line Terminals
62.5- 299	300
300 - 699	200
700 - 999	150
1 000 -2 499	125
2 500 -9 999	60
10 000 up	50
5000 kva up	Residual-Component T.I.F.* 30

*There is no standard for machines of less than 2000 volts.

sults since. Where trouble exists or can be anticipated from difficult exposure conditions, and where a grounded-neutral machine is to be used, it is recommended¹⁰ that the purchaser obtain from the manufacturer a quotation on a machine with the foregoing limit, and in addition an alternate quotation on a machine with a residual-component T.I.F. not to exceed 2.5. This figure of 2.5 for T.I.F. is intended to cover a machine having a two-thirds pitch winding or an equivalent wave shape obtained in some other manner. Special filters or resonant shunts for the few cases of trouble may provide a more economical solution than having all machines with low T.I.F. levels.

Specifications for residual-component T.I.F. are not applicable to machines without neutral leads brought out for grounding; they should not be applied to grounded machines unless the system connections are such that zero-sequence harmonics in the machines can be impressed on aerial power circuits that may now or in the future parallel communication circuits. Thus, residual-component T.I.F. is not applicable to the frequently-occurring case of a machine with neutral grounded but which is separated from distribution circuits by a two-winding transformer with at least one set of its windings connected in delta.

When a synchronous machine is connected to a system, paths are provided for currents produced by the harmonic voltages generated in the machine or in the external circuit. These harmonic voltages and currents can be calculated on the basis of internal or generated harmonic voltages and the harmonic impedances of the system (discussed subsequently) and the harmonic reactances of the machine. The internal harmonic voltages of a loaded machine can be greater or less than the no-load normal-voltage value of the harmonics, but are generally taken the same for calculating purposes. The internal reactances at harmonic frequencies are commonly expressed in terms of an equivalent fundamental-frequency value multiplied by the order of the harmonic. This equivalent fundamental-frequency reactance is based on (1) the negative-sequence reactance for positive- or negative-sequence harmonics and (2) the zero-sequence reactance for the zero-sequence harmonics. The equivalent fundamental-frequency reactance for positive- or negative-sequence harmonics is reduced at the higher frequencies because of the smaller amount of flux penetrating the rotor. The amount of reduction is not known accurately but normally is taken as unity for 60 cycles and about 0.8 at 1000 cycles and in proportion for other frequencies.

Synchronous Converters—In the a-c circuits, synchronous converters produce harmonics that are characteristic of synchronous machines as previously discussed. There are also relatively large 5th and 7th harmonics, which are produced by the successive connection and disconnection of winding sections to the d-c output circuit by the commutator and collector rings. In addition, synchronous converters produce in the d-c circuits harmonics due to slots and commutation that are characteristic of d-c machines.

Induction Motors—The harmonics produced by induction motors are rarely important in noise-frequency coordination. The most important harmonics produced by an induction motor are caused by reluctance changes introduced by stator and rotor slots and their harmonic frequencies are:

$$F_s = (S_s)(rps) \pm f \tag{20}$$

$$F_r = (S_r)(rps) \pm f \tag{21}$$

where F_s, F_r —slot frequencies due to stator and rotor slots, respectively

S_s, S_r —total number of stator and rotor slots, respectively

rps —speed of rotor in revolutions per second

f —generated frequency, normally 60 cycles.

The slot harmonics occur in pairs for both stator and rotor slots. These frequencies are related to the actual speed of the induction motor and vary with the slip. Certain slot combinations are undesirable, as for example one that would cause one of the harmonics from stator slots to be the same as one caused by the rotor slots. In addition, other harmonics, principally the 2nd harmonic, can be produced by saturation, mainly in the teeth. The magnitudes of the harmonics vary with the character of the slot, being relatively small for closed slots and large for open slots.

The harmonic voltages produced by an induction motor can be measured only when connected to a source of excitation. Thus, induction motors do not have a characteristic wave shape in the same sense as synchronous machines and no standard method of determining their wave shape has been proposed. In spite of the enormous quantity of induction motors that have been built, only a very few have been involved in noise-frequency coordination problems. In cases of trouble other contributing factors are frequently present, such as resonance in the supply system to the particular slot frequencies generated in the induction motor. In the few cases of trouble, solutions have been obtained by shunt filters or even shunt capacitors, or by changing the motor to another design giving different slot frequencies, thus avoiding resonance with the supply circuit.

D-c Machines—Harmonics in d-c machines are due principally to the slots and commutators and their values are:

$$F_s = S(rps) \tag{22}$$

$$F_c = C(rps) \tag{23}$$

where F_s, F_c —slot and commutator frequencies, respectively

S, C —number of slots and commutator bars, respectively

rps —machine speed, revolutions per second

In addition, harmonics of double the slot and commutator frequencies may be present because of saturation in the magnetic circuits which occurs principally in the armature teeth. The harmonic current can be estimated from the harmonic generated voltage, the harmonic impedance of the external circuit and the harmonic inductance of the machine. The approximate internal inductance of d-c machines is given by the following equation:

$$L_{int} = \frac{150}{kw} \left(\frac{V_{dc}}{600} \right)^2 \text{ millihenries} \tag{24}$$

where kw —rating of machine in kilowatts
 V_{dc} —machine d-c voltage

In particular cases, it may be found desirable to employ machines having especially good wave shape or to use filtering equipment.

Transformers—Saturation of iron in the magnetic circuit of a transformer is its only inherent characteristic that tends to distort the wave shape of a power system. The term "saturation" as used in this chapter may be defined as a deviation from a linear relation of the magnetic flux in the iron and the magnetizing force. If saturation exists, the application of sinusoidal voltage to a transformer will produce non-sinusoidal exciting current and conversely the flow of sinusoidal current will be accompanied by non-sinusoidal voltages across the primary and secondary windings of the transformer. Both the distortion in voltage and exciting current may be important in inductive coordination. It is impractical, however, to build transformers without saturation, and as a consequence, this source of wave-shape distortion is unavoidable.

The phenomena accompanying saturation in a transformer can be analyzed with the aid of equivalent circuits using leakage and magnetizing reactances of the transformer. In the equivalent-T network, shown in Fig. 18,

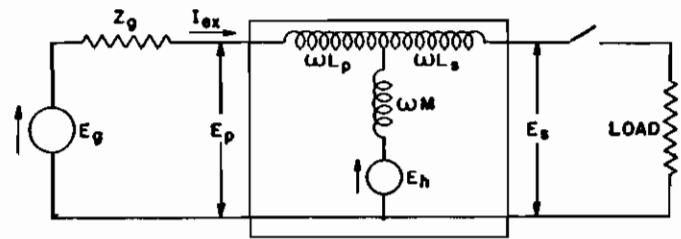

Fig. 18—Equivalent circuit for analyzing harmonic voltages and currents due to saturation in a transformer.

- E_g —Sinusoidal fundamental-frequency source (impedanceless in itself).
- Z_g —Impedance of source, different values for different harmonic frequencies.
- E_p, E_s —Primary and secondary voltages.
- L_p, L_s —Leakage inductances associated with primary and secondary windings.
- M —Mutual inductance of transformer windings.
- E_h —Fictitious impedanceless sources of harmonic voltages of different magnitudes at different frequencies.
- I_{ex} —Exciting current due to sources E_g and E_h .

the leakage reactance is divided into two parts, which are associated with the primary and secondary windings. The division of leakage reactance between the two windings can be estimated from the amount of each winding that is closest to the core. In Fig. 18 the source is represented by an impedanceless generator of sinusoidal fundamental frequency and a "source impedance" that can vary through wide ranges of values, particularly at the harmonic frequencies. It is convenient to think of the harmonic frequencies as being produced by impedanceless harmonic-voltage source E_h connected in series with branch ωM of the equivalent network. These harmonic sources include for a single-phase unit all the odd harmonics with magnitudes decreasing as the order of the harmonic increases. Thus, all the harmonic-frequency loss and reactive kva are supplied to the transformer at fundamental frequency and there converted by the nonlinearity in the magnetic circuit to harmonic sources, which cause harmonic currents to flow back through the actual source. This conception of the equivalent circuit for representing harmonics produced by saturation should be considered as an approximation but it is useful for analyzing transformer operation from the standpoint of the coordination of power and communication systems.

The equivalent circuit of Fig. 18 will now be used to examine the distortion in voltage or exciting current of transformers for various circuit conditions. Consider first an impedanceless source of sinusoidal wave shape, a condition frequently approached in actual operation. Under this condition the primary voltage is sinusoidal but the exciting current contains harmonic components produced by the harmonic sources E_h which cause currents to flow through the impedanceless fundamental-frequency source. The secondary voltage contains some distortion because of the leakage between primary and secondary windings. The secondary harmonic voltage can be estimated if the harmonic components of exciting current and the equivalent primary leakage reactance are known. Consider next the case of a sinusoidal source of low impedance at fundamental frequency but of infinite impedances at harmonic frequencies. Under this condition the exciting current is of fundamental frequency only, but the primary and secondary voltages contain large harmonic components. Occasionally such a condition is approximated under actual operation as when a small transformer carries rated current composed solely of the exciting currents of other transformers. This results in a secondary voltage of badly distorted wave shape. On many systems the supply circuit is of relatively high impedance for particular harmonics so that the corresponding harmonic components of exciting current are suppressed and the corresponding harmonic voltages are increased. This particular condition is frequently encountered with banks of transformers with connections that do not provide a path for the flow of triple-harmonic exciting currents. If a load is connected to the secondary of the equivalent circuit of Fig. 18, it is evident that the harmonic currents will divide between primary and secondary windings. If one of these circuits is resonant at a particular harmonic frequency, then all that harmonic component of exciting current will flow through that transformer winding. If a power system is

maintained constant except for variation in the source impedance at one harmonic frequency, there will be changes in the voltages and currents of other harmonic frequencies. Because of this, there is little reason to undertake accurate calculation of harmonic voltages and currents except for the lower frequencies. Harmonic voltages in the power sources may increase or decrease the harmonic exciting currents, particularly the components flowing in one of the transformer windings. Theoretically, a supply voltage containing harmonics of the proper frequencies, magnitudes, and phase relations can produce sinusoidal exciting current. Sometimes a harmonic in the source and resonance of the transformer with the source impedance at the same frequency produce unexpectedly large distortion of the current or voltage waves.

It is the harmonic components rather than the fundamental-frequency component of exciting current that are important in noise-frequency coordination. However, the harmonic currents can usually be correlated with the total exciting current. The magnitudes of exciting current for typical transformer classes and kva sizes are given in Chap.

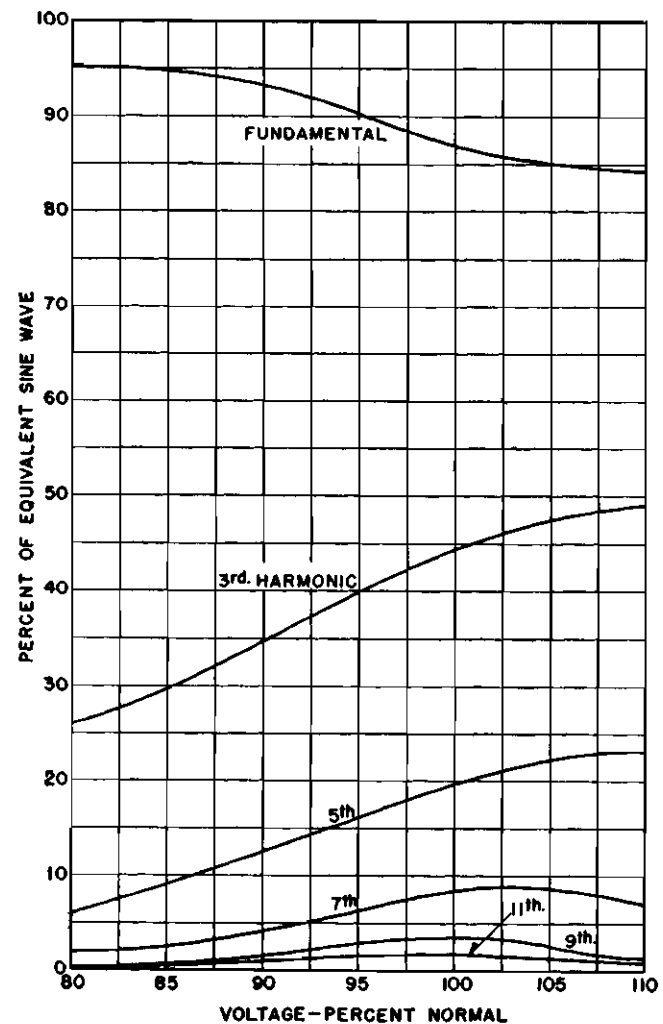

Fig. 19—Fundamental and harmonic components of exciting current for different applied voltages—based on silicon iron used in transformers. For variation of exciting current with voltage see Fig. 40 of Chap. 5.

5. Exciting currents vary importantly with voltage, increasing somewhat more than two to one for each ten percent increase in voltage. Chapter 5 also gives typical curves of exciting-current variation with applied voltage. Examination of such curves emphasizes the importance of avoiding over-excitation of transformers.

Typical harmonic composition of exciting current for silicon iron used at commercial densities in transformers is given in Fig. 19. This curve is based on the free flow

well, and the higher harmonics will likely show wide divergence.

With single-phase transformers supplied from single-phase systems, there is normally a low-impedance path for the flow of all odd-harmonic frequencies produced by transformer saturation. When single-phase transformers are connected in three-phase banks and supplied from three-phase systems, the odd non-triple harmonic exciting currents can flow because they are of positive- or negative-

TABLE 4—TRIPLE-HARMONIC VOLTAGE AND CURRENT CHARACTERISTICS OF COMMON TRANSFORMER CONNECTIONS.

CASE	CONNECTIONS		EQUIVALENT CIRCUIT FOR TRIPLE HARMONICS (SEE FIG. 18)	TRIPLE-HARMONIC VOLTAGE TO GND AT STAR POINT	CIRCUIT TRIPLE HARMONICS			
	PRIMARY	SECONDARY			CURRENTS		VOLTAGES	
					PRIMARY	SECONDARY	PRIMARY	SECONDARY
1				---	NONE	NONE	NONE	NONE
2				SMALL	NONE	NONE	NONE	NONE
3				---	NONE	(a) SMALL (b) NEGLIGIBLE	NONE	SMALL
4				---	(a) LARGE (b) SMALL	(a) LARGE (b) SMALL	(a) SMALL (b) LARGE	(a) SMALL (b) LARGE
5				(a) SMALL (b) LARGE	(a) LARGE (b) SMALL	NONE NONE	(a) SMALL (b) LARGE	(a) SMALL (b) LARGE
6				LARGE	NONE	NONE	LARGE	LARGE

(a) FOR LOW IMPEDANCE TO TRIPLES OF THE SECONDARY OF CASE 3, PRIMARY OR SECONDARY OR BOTH OF CASE 4, & PRIMARY OF CASE 5.
(b) FOR HIGH IMPEDANCE TO TRIPLES OF THE SECONDARY OF CASE 3, BOTH PRIMARY AND SECONDARY OF CASE 4, AND PRIMARY OF CASE 5.

of all the harmonic exciting currents required. The curve can be applied to single-phase transformers with low-impedance sources and to three-phase banks that also include a low-impedance path for triple harmonics. The harmonic components of exciting currents increase rapidly with overvoltage, more rapidly than the total exciting current as indicated in Fig. 19. If a transformer is shifted from one location to another or from one system to another and the exciting currents are compared, it will be found that the total exciting currents will usually correspond, the third- and fifth-harmonic components will check approximately, the 7th- and 9th-harmonics will check less

sequence as pointed out previously. However, the flow of triple-harmonic exciting currents, which are of zero-sequence, depends upon whether the transformer, the supply-system connections or load circuit provides such a path. That the triple harmonics are zero-sequence becomes evident from plots of the fundamental and the triple harmonics for each phase in corresponding phase position to the fundamental which is symmetrically displaced. The actual triple-harmonic voltage and current distribution for the six common forms of two-winding transformers arranged in three-phase banks is illustrated in Table 4. For each of these connections the equivalent

circuit of Fig. 18 has been modified for the representation of zero-sequence harmonics. Thus, the harmonic sources E_h are of triple-harmonic frequency only. The connection of the transformers in the equivalent circuit of Table 4 provide: (1) for delta windings, a path for the flow of triple-harmonic exciting currents within the transformer, (2) for grounded-star connection, a path for the triple-harmonic exciting currents through the external circuit if it is complete, and (3) for ungrounded-star connection, no path is provided for triples either in the transformer or through the external circuit. The distribution of harmonic voltages can be estimated from the triple-harmonic currents flowing through the transformer connection in a manner analogous to that previously described in connection with single-phase transformers on a single-phase system. The results of such analyses are summarized for easy reference in Table 4. Triple-harmonic voltages appear between line and neutral but distribution of voltage between neutral point and ground and line terminals and ground depends on the impedance between these terminals and ground. Thus, for the extreme conditions (1) if the neutral is grounded the triple-harmonic voltages appear between line terminals and ground and are impressed on the external circuit and (2) if the neutral is ungrounded the triple-harmonic voltages appear between neutral and ground and are not impressed on the external circuit.

Three-winding transformers made up of single-phase units can be treated like two-winding transformers. These equivalent circuits may be of either the equivalent- T form with one magnetizing branch and three branches of equivalent leakage reactance or of the equivalent- π form with three magnetizing branches and three leakage reactance branches. Frequently one of the windings does not permit the flow of triple-harmonic currents. This results in a corresponding simplification of the equivalent circuit for determining harmonic-current flow. The interconnected-star can be considered as a special case of the three-winding transformer. Triple-harmonic voltages can appear between the two halves of an interconnected-star winding of symmetrical design but not between line and ground terminals on the interconnected-star side.

Three-phase shell-type transformers have characteristics that correspond to three-phase banks of single-phase transformers of the same electrical connection. In the case of three-phase three-legged core transformers the triple-harmonic fluxes are in the same direction in the same cores at the same time. Consequently, the triple-harmonic exciting currents are suppressed because the resultant leakage path includes a large air path. However, the reluctances of these magnetic circuits are unequal in the three phases, consequently, the exciting currents are not balanced and some exciting current does flow through the neutral.

Phase-shifting transformers may have at the neutral end auxiliary-circuit units that may require consideration in inductive coordination. Ordinarily, however, they are unimportant because of the small exciting kva required. The problem can, however, be analyzed as described for other transformers.

Coordination problems are rarely caused by transform-

ers with delta-connected windings. Occasionally system connections require star-star connections in order to ground the system on both sides or to permit use of auto-transformers. Sometimes transformers originally designed for delta grounded-star connection are reconnected in star-star because of a $\sqrt{3}$ increase in voltage on the delta-winding side. For these it is common practice to use tertiary-delta windings of low reactance having a capacity at least 35 percent of that of the transformer rating. It may be desirable here to limit the triple-harmonic voltages by providing suitable low-impedance paths through other equipment. This can be done by a grounded star-connected generator or by grounded star-delta or grounded interconnected-star transformers. It is important to avoid the creation of a coordination problem because of the triple-harmonic currents that flow through the connecting circuit. In addition, it is also necessary to consider the possible effect of triple-harmonic voltages produced by the generator and impressed on the external circuit through the grounded star-star connections. The use of a generator to provide a path for triple harmonics is usually impracticable if there is an exposure on the intervening circuit, unless the generator has low triple-harmonic voltages as with a two-thirds pitch winding. The triple-harmonic voltages appearing in the external circuit can be estimated from the triple-harmonic exciting currents and the reactances of the external circuit.

If transformers are the cause of harmonic distortion, this fact can usually be established by varying the fundamental-frequency voltage of various system elements. A 10 percent increase in system voltage will be accompanied by an approximately 10 percent increase in harmonics if contributed by a particular rotating machine or rectifier and by a roughly 2 to 1 increase in harmonics if contributed by a particular transformer. This provides a practical basis for studying the effects produced by individual transformers.

If transformers draw large magnetizing currents and if the supply reactances are relatively high, the combination can produce relatively high harmonic voltages, particularly for the 5th harmonic. These harmonic voltages can be reduced by providing nearby a low-impedance path for the particular harmonic. Such a path can be obtained by shunt capacitors or preferably shunt capacitors in combination with reactors tuned to the selected frequency. The harmonic distribution of voltages and currents in a system can be calculated by setting up the equivalent circuit for the system separately for each harmonic frequency. For each transformer, the equivalent circuit should be made as shown in Fig. 18 with the internal harmonic voltages and exciting reactances adjusted to give harmonic currents in the external circuits that correspond to the particular transformer designs. The internal harmonic voltages for each transformer can be taken at an assumed phase relation with the fundamental-frequency voltage at the transformer location and these phase positions related to each other in accordance with the differences in phase relations of the fundamental-frequency voltages at these locations. The a-c network calculator may be used advantageously in solving such harmonic-distribution problems. Further discussion of this method and the results of field tests,

both with and without capacitors are given by Feaster and Harder¹¹.

Shunt Capacitors*—Unlike rotating machines or transformers, capacitors are not, in themselves, sources of harmonics. However, the addition of a capacitor to a circuit will have important effects on the circuit impedances. If harmonics exist in the circuit, then the change in circuit impedance caused by the addition of the capacitor may substantially increase or decrease the harmonic current flowing in the various parts of the circuit. This depends upon the impedances of the capacitor and the remainder of the circuit and upon their relation to the particular harmonic frequencies present.

The elements of the coordination problem with capacitors can be illustrated by a simple series circuit as shown in Fig. 20. The calculated impedances of this circuit over

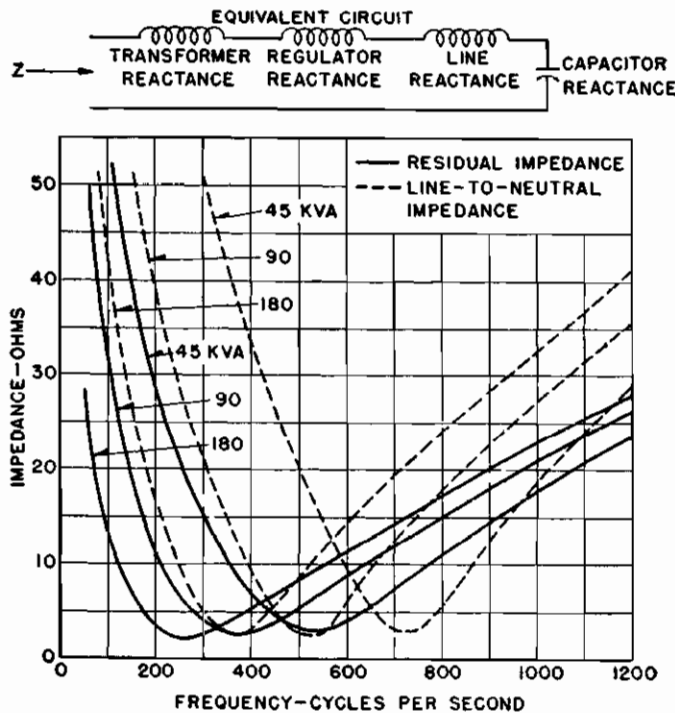

Fig. 20—Effect of capacitors on circuit impedance—calculations based on a two-mile 4-kv circuit.

the frequency range for both the balanced or positive-sequence currents and for the residual currents (three times zero-sequence currents) are plotted in this figure. These curves show how resonance to particular harmonics can be avoided by suitable choice of capacitor size.

When the generated harmonic in the source is of or near the resonant frequency of the circuit with the capacitor connected, there will be an increase in the harmonic voltage drop across the capacitor. When the generated harmonic voltages are well above the resonant frequency of the circuit, there will be some increase in harmonic current resulting from the addition of the capacitor, but the harmonic voltage at the location of the capacitor will be materially reduced. In certain situations, this reduction in harmonic voltage may result in substantial decrease of

*This section is abridged from reference 12.

noise in paralleling telephone circuits for exposures beyond the capacitor location.

The importance of these resonance conditions from the standpoint of inductive coordination depends upon the following power-system characteristics:

Magnitudes and frequencies of the harmonic voltages impressed on the distribution circuit.

Type of distribution system—delta, or wye grounded at substation only, or with neutral-wire grounded at substation and other points†.

Type of capacitor installations—single-phase, or three-phase delta or wye.

Some possible measures applicable to a power system for limiting influence factors increased by a capacitor will now be discussed.

(a) When capacitors are connected in outlying sections to single-phase extensions consisting of a phase wire and multi-grounded neutral, the likelihood of noise induction is greater than if the capacitors are connected in three-phase banks on the three-phase portion of the feeder. This is because of the possibility of long exposures and open-wire telephone circuits in the outlying areas. The connection of capacitors as three-phase banks, rather than individual units on single-phase extensions, usually results in lower power-circuit influence. (b) Where the induction from ground-return currents would otherwise tend to predominate as, for example, in distribution systems with multi-grounded neutral wire, the connection of the capacitors from phase wire to phase wire in the three-phase section minimizes the ground-return currents. (c) A low-voltage gap (instead of a direct connection) between the neutral of a wye-connected capacitor bank and the multi-grounded neutral conductor also is effective in minimizing the ground-return current. Such a gap, if properly set, sparks over when a fault occurs in a capacitor unit in one phase, thus preventing sustained overvoltage (line-to-line voltage) on the remaining capacitor phases. On 4000-volt wye circuits, the gap is so small that it is difficult to maintain. (d) A change in the size of the capacitor on a feeder or in the number of capacitors on a feeder changes the resonant frequency. Knowing the wave shape of the impressed voltage and the constants of the supply system and distribution circuit, a capacitor size or location with decreased inductive influence can be chosen. (e) Another method is to connect an auxiliary reactor in series with the capacitor on each phase. Such a reactor should have a 60-cycle impedance of about five percent of the line-to-neutral impedance of the capacitor and the combination, in effect, appears as a resonant shunt at a frequency of about 270 cycles. On a multi-grounded system this arrangement, theoretically, is particularly effective in minimizing the ground-return currents at frequencies of 300 cycles and above. Some increase in the 180-cycle component may occur in the case of capacitors connected from phase wires to neutral. This arrangement is probably effective in all cases except where the noise induction is controlled by the

†These two forms of grounding are frequently termed uni-grounding and multi-grounding.

180-cycle ground-return currents. An auxiliary reactor of this type increases the 60-cycle impressed voltage across the capacitor by about five percent, and increases the capacitor kva by 10 percent, but the net kva of the installation by only five percent. (f) A similar reactor in the neutral of a wye-connected capacitor can be used to reduce the noise induction caused by residual components. Such a reactor should have a 60-cycle impedance of about four percent of the line-to-neutral impedance of the capacitor,

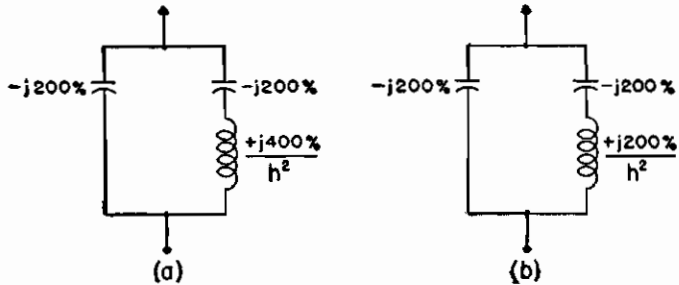

Fig. 21—Schematic diagram illustrating use of reactors in a capacitor installation to give in the external circuit:

- (a)—Open circuit to the h th harmonic.
- (b)—Short circuit to the h th harmonic.

All reactances in the figure are 60-cycle values on capacitor-bank rating.

the combination constituting a resonant shunt at 180 cycles in the residual circuit. It destroys any resonant condition, in the residual circuit, between the capacitor and the line, and reduces all harmonic residual currents.

The installation of a shunt capacitor may increase harmonic currents or voltages on a system. By adding an appropriate amount of reactance in the shunt capacitor the effects of resonance to a particular harmonic can be minimized and the harmonic current drawn over a particular path can be controlled. Fig. 21 has been prepared to illustrate the range of effects that can be obtained. Sometimes it is desirable to provide a resonant shunt at the capacitor location, as illustrated in Fig. 21 (b), in order to minimize the harmonic voltages impressed on the circuit beyond the capacitor. At other times it is undesirable, as a result of a capacitor installation, to draw additional harmonic currents over a particular circuit. To avoid this, the capacitor

may be provided with a reactor as shown in Fig. 21 (a). This combination constitutes a blocking filter and acts as an open circuit to the selected frequency insofar as external circuits are concerned. However, harmonic currents flow in the capacitor as determined by the harmonic voltages impressed upon it. Further discussion of resonant

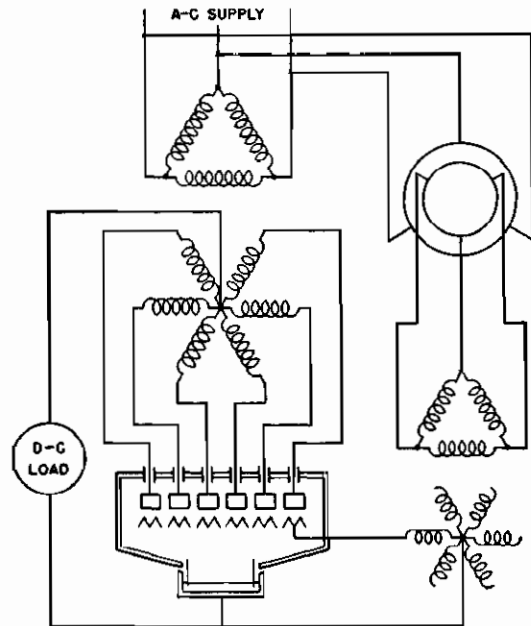

Fig. 22—Schematic wiring diagram of a diametrical six-phase rectifier with grid control by a-c voltage of variable phase position.

shunts and blocking filters are given in the latter part of this section.

Rectifiers and Inverters—With rectifiers and inverters of the ignitron, multi-anode tank or glass-tube types, the alternate periods of conduction and non-conduction for fractional parts of a cycle produce harmonics in both the a-c and d-c circuits. The schematic diagram of a six-phase star rectifier with control grids is shown in Fig. 22 and the conventional voltage- and current-wave shapes for different conditions of rectifier and inverter operation are as shown in Fig. 23. The d-c voltage wave is shown by the

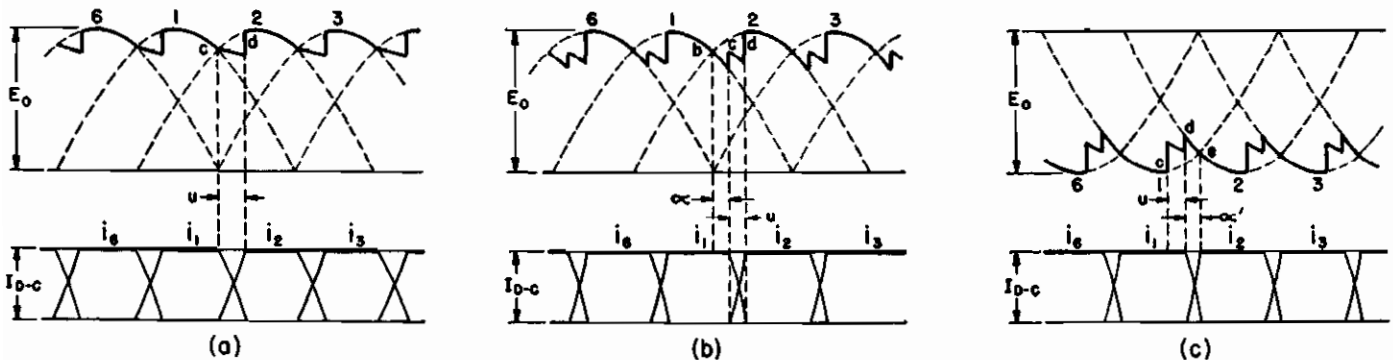

Fig. 23—Instantaneous voltage and current diagrams of diametrical six-phase rectifier for operation as:

- (a)—Rectifier without grid control.
- (b)—Grid-controlled rectifier.
- (c)—Inverter.

u —Angle of overlap—electrical degrees.
 α —Angle of grid delay—electrical degrees.
 $(u + \alpha')$ —Angle of advance (firing)—electrical degrees.
 For other quantities see text.

Load circuit assumed to be of infinite inductance.

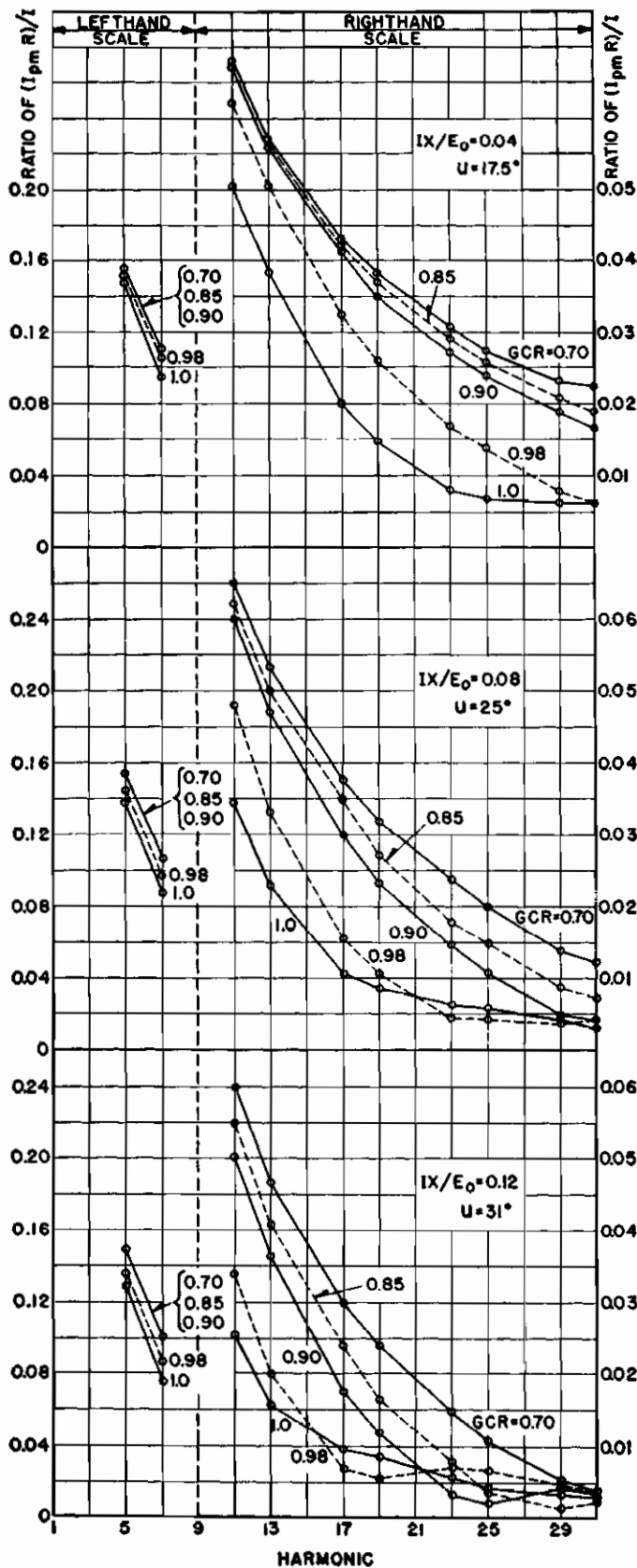

Fig. 25—Harmonic currents in the a-c supply of rectifiers and inverters with control grids. Curves plotted in three sets for three ratios of IX/E_0 , each set plotted for five values of voltage reduction by grid control for rectifiers. Same curves may be

is started in anode 1 at the instant c , and transfer takes place at the end of the commutating period corresponding to the angle u . The end of the conducting period must be sufficiently in advance of the point e , otherwise, transfer cannot be made and proper inverter operation cannot be secured. The angle α' corresponds to the time available for deionization.

The voltage and current-wave shapes of Fig. 23 can be used in a Fourier analysis to obtain the a-c and d-c harmonics of rectifiers with and without grid control and of inverters^{13,14}. In this method as applied to the six-phase rectifier, the a-c currents are obtained by using, for example, a positive wave for one-half of a cycle and a negative wave from another phase for the other half of the cycle. The instantaneous anode current during commutation is defined by:

$$i = I \left(\frac{\cos \alpha - \cos (\theta + \alpha)}{\cos \alpha - \cos (u + \alpha)} \right) \quad (28)$$

where I, u, α —meaning previously described
 θ —represents time in electrical degrees

Harmonic currents in the a-c supply circuits are affected by the amount of grid control present, that is, by the magnitude of the angle of retardation α and the angle of advance $(u + \alpha')$, and also by the factor IX/E_0 . Commercial power rectifiers rarely have less than six phases, consequently, the a-c harmonics given in Fig. 25 are in terms of a six-phase rectifier, which may be of any of the conventional types so long as the direct current per phase group remains the same*. The harmonic frequencies of currents in the primary of a rectifier transformer are as shown in Table 5. With more than six rectifier phases, certain groups of harmonics produced by a six-phase rectifier are theoretically eliminated, and practically are greatly reduced. Tests conducted by the Edison Electric Institute and the Bell Telephone System† indicate that the suppressed harmonics for rectifiers of more than six phases are approximately one-fifth the six-phase values. Thus, a 12-phase rectifier would be expected to have 5th and 7th, 17th and 19th harmonics, etc., of approximately one-fifth those found in six-phase rectifiers, but the 11th, 13th, 23rd harmonics, etc., would correspond to the sum of the harmonics of the two six-phase units comprising the 12-phase arrangement.

The foregoing discussion of a-c harmonics has been based on an inductive supply circuit of linear frequency-impedance characteristic. When this condition is satisfied the theoretical method of estimating the harmonics in the a-c supply circuit gives very good results. In case the

*The phase relation of the harmonics with respect to the fundamental change for the different rectifier connections of the same number of secondary phases.

†Engineering Report No. 22 or Reference 4.

used for inverters with angles of advance firing corresponding to angle of grid delay with rectifiers. Based on Evans and Muller¹⁵.

I_{pm} —Primary current of the m th harmonic.

I —Direct current for each rectifier phase group.

R —Ratio of primary to secondary voltages—both line-to-neutral. For connections with interphase units use curve directly for 6-phase double-wye, multiply ordinate by 1.932 for 12-phase quadruple-wye.

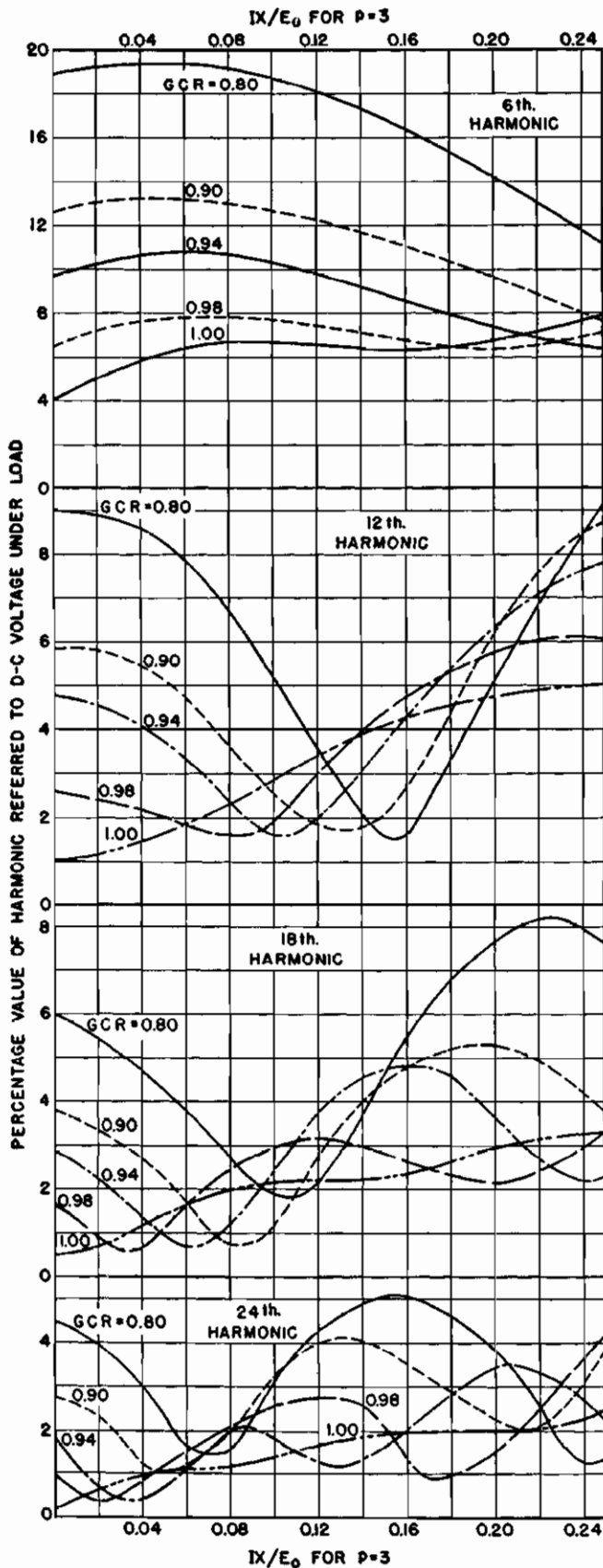

Fig. 26—D-c internal harmonic voltages of a rectifier with grid control supplying a load circuit of infinite inductance. Curves are plotted for each harmonic frequency as a function of the

supply-circuit frequency-impedance curve is not linear, the approximation may be used of computing the magnitude of the harmonics on the basis of fictitious reactances equal to the actual reactance at the harmonic frequency divided by the order of the harmonic.

The harmonic voltages in the supply can be computed from the harmonic currents and the impedances of the supply circuit at harmonic frequencies. The impedance of machines at harmonic frequencies can be considered equal to the negative-sequence impedance of the machines multiplied by the order of the harmonic and by a factor less than one. This factor varies from one at 60 cycles to perhaps 0.8 at 1000 cycles.

The order of the harmonics in the d-c circuit is shown in Table 5. The harmonics in the d-c output voltage wave are similarly obtained by the Fourier method from the d-c voltage waves of Fig. 23. Results of this analysis¹⁴ are given in Fig. 26 which gives the 6th, 12th, 18th, and 24th harmonics as percent of the d-c output voltages under load. The harmonic current flowing in the d-c circuit can be estimated from the magnitude of the harmonic voltages obtained from Fig. 26, taking into account the harmonic impedance of the load circuit and the internal inductance of the rectifier transformer, estimated from

$$L_{int} = \left(\frac{95}{kw}\right) \left(\frac{60}{f}\right) \left(\frac{E_{dc}}{600}\right)^2 \text{ millihenries} \quad (29)$$

The distortion of the current wave shape in the a-c circuit is greater (1) with low-reactance supply systems than with high-reactance systems, (2) with grid control than with non-grid control, and (3) with few rectifier phases than with a large number. Harmonics in the d-c output increase with load and generally with the reactance of the supply system and decrease as the number of rectifier phases increases. The overall influence characteristic or T.I.F. values decrease approximately one-half when using a 12-phase rectifier in place of a six-phase.

With a large number of anodes it is possible to use a large number of rectifier phases, the maximum being equal to the number of anodes. Ordinarily rectifiers are arranged in double three-phase groups giving the equivalent of a six-phase rectifier. Two such sets with anode voltages-to-neutral displaced 30 electrical degrees give the equivalent of a 12-phase rectifier. Similarly, a 24-phase rectifier can be obtained by using four six-phase groups displaced 15 degrees. In some large rectifier installations for electrochemical purposes a large number of anodes are required. Thus, 30, 60, and even as high as 72 phases are readily possible and have been built. With all rectifiers in operation good current and voltage wave shapes are obtained. However, consideration must be given to operation with a single six-phase unit or a string of six-phase units out of service. Under such conditions the harmonics in the supply system for all rectifiers will correspond to the vector sum of those for the total balanced load and the negative of those for the six-phase unit taken out of service. Thus, if five units are in operation to form a 30-phase rectifier,

ratio of IX/E_0 with a family of curves for five different ratios of voltage reduction by grid control—based on Stebbins and Frick¹⁴.

the disconnection of one six-phase unit will produce harmonics which correspond approximately to one-fifth of the total load supplied by a six-phase rectifier and in addition those that correspond to the total load supplied by a 30-phase rectifier. The resultant harmonic conditions are approximately the same as those produced by somewhat more than one-fifth of the total load supplied by a six-phase rectifier.

When a rectifier or inverter is installed and connected to a-c or d-c circuits, which now or in the future may be involved in an inductive exposure, the coordination aspects of the problem should receive consideration. The influence characteristics of a rectifier or inverter are definite for a particular power-supply system if the rectifier load, number of rectifier phases, and amount of voltage control are specified. The foregoing indicates the benefits obtainable from a larger number of rectifier phases or by limiting the amount of grid control. A combination of voltage control with tap changers will produce lower influence factors than one that uses voltage reduction by grid control. Substantial reduction in the harmonics caused by rectifiers of a definite number of phases can be accomplished only with auxiliary equipment, which entails additional cost. Other methods of coordination applicable to the power or communication system may afford a more economical solution. The procedure to be followed when an inductive exposure is possible is outlined in the following excerpt from the recommendations of the Electrical Equipment Committee of the Edison Electric Institute¹⁵.

"In any particular situation consideration should be given by the prospective purchaser to the coordinative measures that may be applied in both power and telephone systems, in accordance with the 'Principles and Practices for the Inductive Coordination of Supply and Signal Systems'^{1(a)}, taking into account possible future, as well as initial, conditions.

"It will generally be found advisable to install a rectifier without specific coordinative measures and then observe conditions, particularly where it is impracticable to make sufficiently accurate estimates of the effect of the rectifier in advance of installation. Experience to date indicates that specific coordinative measures will not be necessary in the majority of cases, particularly if care is given to advance planning of the method of feeding the rectifier. In special cases where there are indications that paralleling communication circuits may be seriously affected, some provisions should be made beforehand for temporary arrangements to take care of the period during which final coordinative measures are being determined and installed.

"When preliminary review indicates that consideration of selective devices in the power system may be necessary after the rectifier has been installed, preliminary cost estimates of these devices* should be obtained from the manufacturer before the purchase of the rectifier equipment so that they may be available in studies relating to the cost of the complete installation.

"It is to be understood that these suggested values may not eliminate the possibility of interference in every case but on the basis of past experience they are believed to be adequate for most of the cases likely to occur.

"If the rectifier gives rise to a noise-interference problem after installation, a joint cooperative study should be made in the

*Characteristics of selective devices that may be assumed for the purpose of this preliminary estimate when the supply frequency is 60 cycles are given in the paragraphs on filtering equipment.

field by the parties affected to determine the best engineering solution. If this solution necessitates the installation of a selective device, its design characteristics should be based upon the actual requirements rather than upon the values of reduction factors employed in the preliminary estimate previously mentioned."

Lighting Circuits—Ordinarily lighting circuits of the constant-potential type are not a factor in coordination problems. However, they may arise with series circuits of the non-adjacent return type or with lamps of arc-discharge type or with auxiliary transformers that become saturated.

Current transformers supplying incandescent or other lamps on series-lighting circuits saturate if the secondary becomes open circuited, as in the event of filament failure. The current wave of the primary circuit remains sinusoidal but the voltage wave becomes distorted on the load side of a constant-current regulator, but usually not on the supply side of the circuit. The inductive effects in adjacent communication circuits may become important if the lighting-circuit return is across the street or in the next block. If only part of the lighting circuit is involved in an inductive exposure, isolating transformers between the parts can be used to minimize the magnitude of induction in the exposure. The most practical solution, however, is to provide a film cutout for connection across the current-transformer secondary. The most successful form of cutout is the disc with a powder which, upon application of high potential, fuses to form a metallic bead that effectively short circuits the current transformer and lamp, thus avoiding the conditions which produce saturation in the transformer.

On series circuits, lamps of the arc-discharge type, including the a-c arc and the sodium-vapor forms, are sources of voltage distortion. Ordinarily these circuits are supplied through constant-current regulators which, because of their high reactance, greatly minimize the distortion of the current wave and of the voltage wave on the supply side of the regulator. The inductive influence of the lighting circuit increases with the number of lamps connected in the circuit. The $KV \cdot T$ factor for a 30-volt, 6.6-ampere lamp is approximately 16 per lamp. There is a slight decrease in the $KV \cdot T$ factor per lamp when a large number of lamps are connected in series which apparently results from partial cancellation of the harmonics as a result of the difference in phase at the individual lamps. Since current distortion is negligible, only electric induction need be considered in coordination work. No problem will exist if either circuit is located in cable with sheath grounded.

The influence characteristics of a series circuit depend upon the balanced and the residual components of harmonic voltages at various points along the circuit. The metallic-circuit $KV \cdot T$ factor increases with the number of lamps in the circuit irrespective of whether they are connected in one side of the circuit or in both. The wire-to-ground and residual $KV \cdot T$ factors are affected by the manner of connecting the lamps in the circuit, that is, whether in one side of the circuit or alternately in both sides as shown in Fig. 27 for an ungrounded circuit. In this figure the wire-to-ground and residual $KV \cdot T$ factors are shown on the basis of equal capacitances to ground

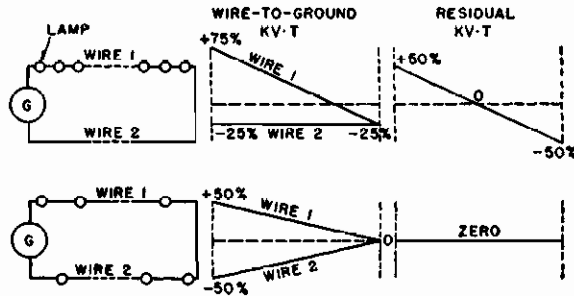

Fig. 27—Distribution of $KV \cdot T$ factors along series lighting circuits.

- (a) All lamps on same side of circuit.
- (b) Adjacent lamps on opposite sides of the circuit.

and equal leakages from the two wires of the circuit, and the lamps being uniformly distributed throughout the length of the circuit. If adjacent lamps are alternately connected in the two sides of the circuit, the residual $KV \cdot T$ factor is zero. If the lighting circuit is accidentally grounded, the maximum residual $KV \cdot T$ factor will occur when the lamps are located in one side only.

The influence of a series-lighting circuit (assumed ungrounded) is a minimum when the two wires of the circuit are kept close together and when adjacent lamps are connected in opposite sides of the circuit. These conditions insure that transpositions in telephone circuits can be made relatively effective. For reasonably uniform exposures at highway separation between open-wire telephone toll circuits and a series lighting circuit on the highway, the noise-induction conditions will not be important¹⁶ if (a) the telephone lead is transposed according to the exposed-line transposition system, or other systems having equal or greater frequency of transposition, and (b) the lighting circuit is not grounded (or is grounded at a balanced point only), the two wires of the circuit occupy adjacent pin positions, and adjacent lamps are connected in opposite sides of the circuit. Noise-induction problems are negligible in situations where only a small number of sodium-vapor lamps are used, for example, at highway intersections.

Fluorescent lamps have wave-shape characteristics similar to those of sodium-vapor or other arc-discharge lamps. However, fluorescent lamps are used on constant-potential circuits and are, therefore, less likely than lamps on series circuits to be involved in coordination problems. In large installations, fluorescent lamps are distributed among the different phases. The phase position at the lamps will vary, with the result that important reductions in harmonics are obtained. Another favorable factor in the application of fluorescent lamps is that they are rarely used in large numbers, except where power-supply or telephone circuits are located in cables, which can provide considerable shielding action against magnetic induction. The current T.I.F.'s of typical fluorescent lamps vary from 30 to 60. Fluorescent lamps are frequently installed with individual shunt capacitors for power-factor correction. Frequently also fluorescent lamps are installed in pairs with reactor-capacitor phase-splitting arrangements to avoid a zero illumination point. When shunt capacitors

are used with fluorescent lamps they may tend to amplify harmonics appearing in the supply circuit, and under some conditions the effect of capacitors at the lamp will be of greater importance than the arc-discharge characteristic of the lamp itself. The use of shunt capacitors at the lamp location presents essentially the same problem as that which occurs with other capacitors on distribution circuits.

Wave-Shape Characteristics of Systems—The harmonic voltages and currents of a particular system can be calculated from wave-shape characteristics of the rotating machines, transformers and rectifiers, and the harmonic-frequency impedances of the connected circuit. The characteristics of the harmonic sources in a-c apparatus and in the d-c circuits of rectifiers have been given in the preceding sections in terms of internal harmonic voltages and internal inductances. For the a-c circuits of rectifiers a method of estimating the harmonic currents and voltages has also been described. In calculating the harmonic-frequency impedance characteristics of a system, the principal problem is the representation of circuit elements

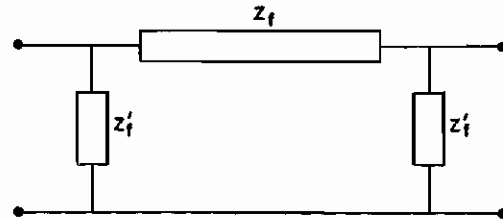

Fig. 28—Equivalent π network for long line with distributed constants. See Eqs. (30) and (31).

with distributed constants. This representation can be made in an approximate way with the equivalent π network of Fig. 28. In this equivalent network resistances are neglected and the series- and shunt-impedance branches are:

$$Z_f = +jhlX_s \frac{\sin \theta}{\theta} \text{ ohms} \tag{30}$$

$$Z'_f = -j \frac{X_c \theta}{hl \tan \frac{\theta}{2}} \text{ ohms} \tag{31}$$

where l —length in miles

X_s —series inductive reactance in ohms per mile at 60 cycles

X_c —shunt capacitive reactance in ohms per mile at 60 cycles

h —order of harmonic frequency using 60 cycles as base

θ —angle of the line calculated from

$$\theta = hl \sqrt{\frac{X_s}{X_c}} \text{ radians} \tag{32}$$

With the equivalent π networks for lines and with the inductance and capacitance characteristics of apparatus, an equivalent circuit of the system for each harmonic frequency can be made. This equivalent circuit can be solved by the aid of network-transformation and reduction methods described in Chap. 4 in connection with the solution of fundamental-frequency problems.

For many purposes it is convenient to have tables of typical power-system harmonic voltages, harmonic currents, *I·T* factors (product of rms current and current T.I.F.), *KV·T* factors (product of rms voltage in kv and voltage T.I.F.) and in addition tables of machine no-load voltage T.I.F., both balanced and residual. Such Tables,

TABLE 6—NON-TRIPLE HARMONIC PHASE-TO-PHASE VOLTAGES

Item	Circuit Voltage Kv	In Percent at Various Frequencies										No. of Tests	
			300	420	660	780	1020	1140	1380	1500	1740		1860
1	2.3	Ave.	1.33	.33	.13	.07	.04	.03	.08	.08	.05	.03	231
		Max.	5.90	1.7	.72	.97	.33	.19	.67	.59	.38	.26	
2	4*	Ave.	.98	.25	.10	.06	.05	.04	.05	.07	.05	.03	383
		Max.	4.6	1.4	.95	.30	.50	.81	.60	1.7	.28	.27	
3	11-13.8	Ave.	1.0	.29	.12	.09	.05	.04	.06	.07	67
		Max.	2.7	.71	.69	.60	.26	.56	.47	.25	
4	19-44	Ave.	1.2	.44	.09	.04	.04	.03	.06	.06	28
		Max.	4.1	1.16	.42	.14	.29	.20	.22	.43	
5	60-69	Ave.	1.1	.35	.13	.17	.04	.03	.03	.03	35
		Max.	3.2	.97	.65	1.0	.23	.18	.15	.11	
6	88-132*	Ave.	2.07	.31	.076	.021	.005	.005	.013	.018	7
		Max.	3.8	.73	.18	.05	.008	.006	.06	.060	

*Harmonics of phase-to-neutral voltage.
 **Grounded 4-wire distribution supplied by delta/star-grounded transformers.

TABLE 7—NON-TRIPLE HARMONIC PHASE CURRENTS

Item	Circuit Voltage Kv	In Percent at Various Frequencies										No. of Tests	
			300	420	660	780	1020	1140	1380	1500	1740		1860
1	2.3	Ave.	1.65	.47	.11	.06	.05	.04	.11	.12	.05	.04	243
		Max.	3.2	4.7	1.3	2.3	.96	1.6	1.4	1.3	3.9	5.3	
2	4	Ave.	1.18	.32	.09	.05	.04	.03	.04	.05	.02	.01	396
		Max.	8.2	7.5	1.2	1.3	.65	1.4	1.1	1.6	.20	.16	
3	11-13.8	Ave.	1.8	.51	.24	.16	.09	.05	.09	.08	157
		Max.	20	7.1	6.8	8.4	2.1	.52	4.8	2.5	
4	19-44	Ave.	4.1	1.2	.35	.18	.10	.07	.22	.17	77
		Max.	16	5.8	2.4	.80	.53	.57	3.1	1.6	
5	60-69	Ave.	3.9	1.3	.35	.20	.09	.07	.09	.09	81
		Max.	45	9.5	5.1	1.7	.94	.49	.79	.82	
6	88-132	Ave.	3.5	1.3	.77	.20	.03	.03	.05	.04	22
		Max.	15	6.1	9.0	1.5	.13	.16	.42	.24	

TABLE 8—RESIDUAL HARMONIC CURRENTS

Item	Circuit Kv	Amperes at Various Frequencies							No. of Tests	
			180	300	420	540	900	1260		1620
1	4.0	Ave.	4.78	.22	.06	.10	.01	.005	.008	266
		Max.	20	2.0	.60	1.3	.61	.89	.89	
2*	11-13.8	Ave.	.54	.05	.02	.05	.04	.03	.06	48
		Max.	4.7	.71	.09	.26	.17	.39	.47	
3**	11-13.8	Ave.	6.96	.08	.06	.22	.02	.02	.10	15
		Max.	25	.45	.15	1.17	.07	.09	.85	
4	19-44	Ave.	.48	.06	.08	.03	.001008	13
		Max.	2.1	.24	.83	.07	.0107	
5	60-69	Ave.	.66	.06	.03	.04	.004	.001	.003	43
		Max.	2.2	.65	.22	.12	.04	.014	.05	
6	80-132	Ave.	.89	.11	.08	.04	.006	.001	.003	18
		Max.	3.0	.41	.51	.15	.032	.006	.016	

*Systems ungrounded or multi-grounded through transformers only.
 **Multi-grounded with at least one ground through a machine neutral.

6, 7, 8, 9 and 10, have been condensed from the report, "System Wave-Shape Survey," the tests for which were conducted from 1927 to 1929 by the National Electric Light Association and Bell Telephone System*. The wave-

*Engineering Report No. 15 of reference 4.

TABLE 9—SUMMARY OF POWER-CIRCUIT INFLUENCE FACTORS
 I·T AND KV·T PRODUCTS
 BASED ON 1919 FREQUENCY WEIGHTING

	Power Circuit Voltage Range (Kilovolts)	I·T Product (Amperes × Current TIF) Magnetic Induction		KV·T Product (Kilovolts line-to-line × Voltage TIF) Electric Induction	
		Average	Maximum	Average	Maximum
Balanced Components	2.3- 4	1,500	23,000	60	400
	11 - 14	2,100	12,000	300	1,400
	19 - 44	1,600	16,000	700	2,000
	60 - 69	1,400	6,000	1,200	3,500
	88 -132	1,400	2,300	1,700	2,300
Residual Components	2.3- 4	0-500	1,100*	No Data	No Data
	11 - 14	10-2700**	400-4800**	No Data	No Data
	19 - 44			15-30	100
	60 - 69	60-800	100-1000	++	50-400
	88 -132			No Data	

*Largest average value—absolute maximum not determined.
 **Upper values were obtained on systems fed by direct-connected generators with grounded neutrals; but note that these conditions alone do not always give high values.
 ++Not enough cases to average.
 Taken from Eng. Report No. 16 of reference 4.

TABLE 10—NO-LOAD VOLTAGE TIF CHARACTERISTICS OF MACHINES

	Balanced TIF (L-L)			Residual Component TIF*		
	Ave.	Max.	No. of Tests	Ave.	Max.	No. of Tests
Synchronous Generators						
Steam.—Kva						
1 000- 2 500	39	105	169
2 501-15 000	18	98	158	15	99	21
15 001-Up	15	110	163	15	66	36
Hydro.—Kva						
0- 999	72	190	116
1 000- 2 500	58	323	110
2 501-15 000	57	590	120	7	13	6
15 001-Up	17	59	25	17	20	4
D-C Generators						
M.G. Sets	109	480	26			
Synchronous Converters	25	103	33			

*Except 2/3 pitch machines.

shape conditions on a particular coordination problem should be compared with the maximum as well as average values from Tables 6 to 10.

Filters for Power Systems—When harmonics on a power system require reduction, consideration may be given to filtering equipment. Filters have important effects on particular harmonic-frequency voltage and current distributions but have little effect on 60-cycle voltages and currents. Filters consist of reactors, capacitors, or a combination of these in units which may or may not be

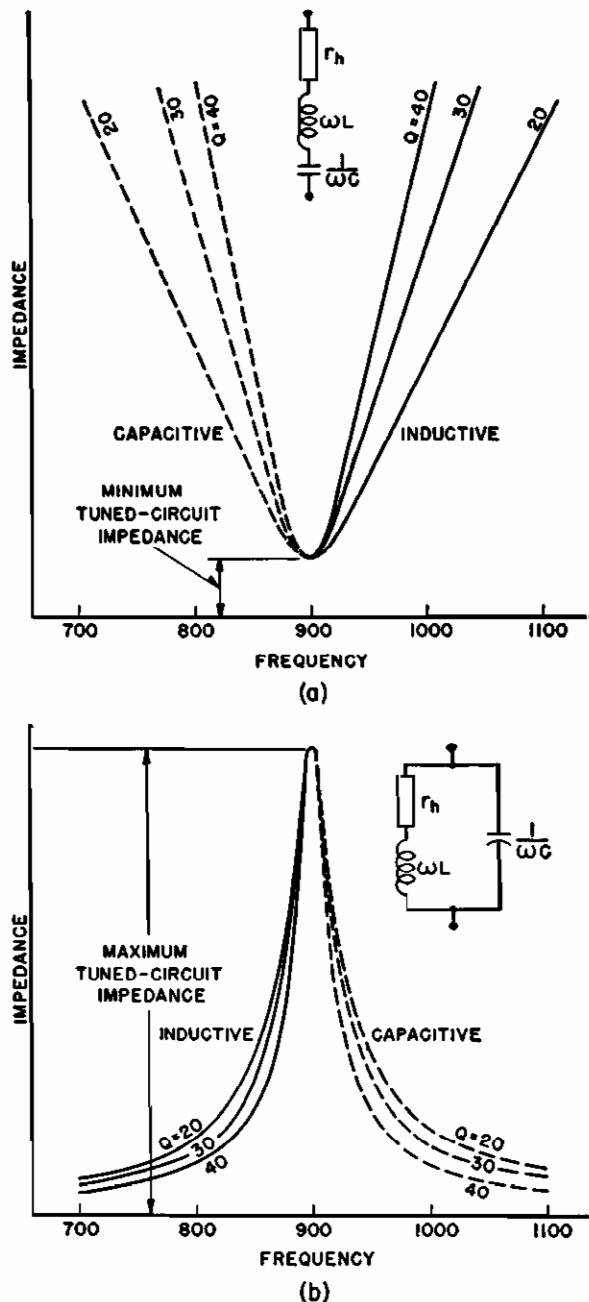

Fig. 29—Frequency-impedance characteristics of filters for several different values of the filter-constant Q .

- (a) Resonant shunt.
- (b) Wave trap.

tuned. Tuned filters are of two types, as illustrated in Fig. 29, namely:

1. Resonant shunts—reactor and capacitor connected in series, the combination being in shunt with the circuit.
2. Wave traps—reactor and capacitor connected in parallel, the combination being in series with the circuit.

The principal characteristics of a resonant shunt or wave trap are the tuned frequency, the tuned impedance, and

the filter constant Q . The constant Q is the ratio of the effective harmonic-frequency reactance of the reactor or capacitor element to the effective harmonic-frequency resistance of the combination, both quantities being at the tuned frequency. The value of Q is normally about 30 but lower values are usually obtained unless special precautions are taken to minimize high-frequency losses. For filters of given tuned-frequency impedance the one with the higher value of Q will require smaller harmonic reactance and frequently smaller volt-ampere capacity. However, a filter of higher Q requires more accurate tuning and is less effective for adjacent harmonic frequencies or for variation in the fundamental frequency of the supply. Thus, for two filters of the same tuned-frequency impedance and the same costs, the one with lower value of Q is usually more desirable.

Tuning of a filter is normally obtained with taps on either the reactor or capacitor element so as to get within $\frac{1}{2}$ percent of the desired natural frequency of the combination. Filters with many capacitors are tuned by selecting the appropriate combination of capacitor units and taps; filters with few capacitors are tuned by adjusting the reactors, using coarse taps and in addition, either fine taps or taps on a suitable auxiliary unit. Filters built in the field are usually tuned by unwinding turns on the reactor until the desired reactance is obtained. Tuning is most conveniently checked by means of a harmonic analyzer, which measures the ratio of the voltage and current at the desired harmonic frequency.

The more common applications for filters, resonant shunts, and wave traps are:

1. Machine-neutral wave trap, or blocking filter.
2. Machine resonant shunt, or by-passing shunt filter.
3. Line shunt filters for modifying resonant characteristic.
4. Rectifier filters which include
 - a. A-c filters
 - b. D-c filters

Machine-neutral wave traps are used when it is desired to reduce the triple-harmonic currents or voltages impressed on a distribution circuit by a synchronous machine con-

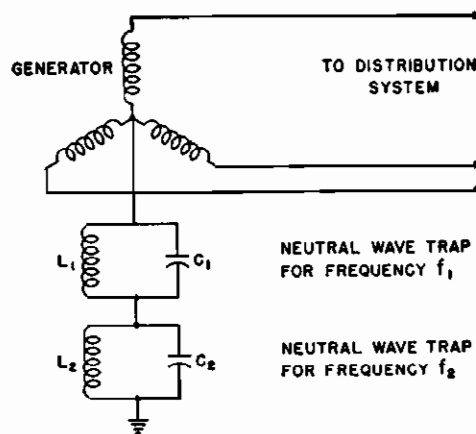

Fig. 30—Synchronous-machine neutral wave trap for suppressing triple-frequency currents f_1 and f_2 —schematic diagram.

nected directly or through star-star transformers. Neutral wave traps consist of one or more units in series between the machine neutral and ground as shown schematically in Fig. 30. In applying a neutral filter, consideration should be given to the following:

1. Suitable tuned-frequency impedance and accurate tuning for each wave trap.
2. Wave trap should withstand fundamental-frequency voltages and currents resulting from single and double line-to-ground faults.
3. The filter should not amplify unduly the currents and voltages for other harmonic frequencies.

The tuned-frequency impedance of each wave trap should be selected to give in combination with the impedance of the machine and external circuit the required reduction in that particular triple-harmonic frequency voltage and current. Neutral resistors are sometimes inserted in the circuit between machine neutral and wave trap to reduce fundamental-frequency voltages and currents impressed on the wave trap. In particular cases, blocking filters in the three phases may be preferred to a neutral filter of high fundamental-frequency inductance for the reasons brought out in the discussion on system transients and grounding in Chaps. 14 and 19. To insure that a filter will not unduly amplify currents and voltages for other harmonic frequencies, it is necessary to know (a) the frequency-impedance characteristic of the distribution circuit as viewed from the machine location, (b) the machine impedance to zero sequence, and (c) the triple-harmonic voltages generated in the machine or on the system. By plotting for the system and the filter a frequency-impedance curve for each harmonic it is possible to estimate whether the magnitude of a particular frequency will be increased. If such a result is obtained, a change in the constants of the network elements may be necessary to give a different impedance at frequencies other than those to be suppressed by the filter.

Machine shunt filters have been employed to by-pass from external circuits the slot-frequency harmonics of machines. Since slot frequencies occur in pairs, the shunt filters are usually built to take care of two frequencies for the lower slot frequencies and a single frequency for the higher slot frequencies. Machine shunt filters are similar to rectifier shunt filters shown schematically in Fig. 32. The design of a filter is usually determined from the internal harmonic voltages of the machine and its harmonic reactance because the filter usually provides substantially a short circuit for these harmonics generated in the machine. The effective tuned-frequency resistance is then chosen so that the harmonic current flowing through it produces a voltage drop that corresponds to the desired reduction in the harmonic voltage applied to the connected circuit. The filter reactor and capacitor constants become definite as soon as the filter-constant Q , the ratio of reactance to resistance at the tuned frequency, has been selected. The required value of Q is usually increased slightly to allow for the imperfection of tuning by taps. In applying shunt filters, it is necessary to consider whether the installation provides a low-impedance path for harmonics originating elsewhere in the system at the same or even different frequencies.

If such a path is provided, harmonic currents may be drawn through the intervening circuit and prevent the desired improvement in the noise-frequency coordination problem. Shunt filters can be located remote from the machine if harmonic currents flowing through the intervening path are not disadvantageous from the coordination standpoint. Such a location, if permissible, will result in smaller volt-ampere capacity in filter parts.

Line resonant shunts have been used in a few instances to prevent amplification of harmonics because of the resonance of a particular feeder at a frequency appearing in the source. The more usual combination is that in which the line capacitance resonates with the inductance of the source. The installation of a line shunt filter may change the resonant point and greatly simplify the coordination problem. Line shunts are sometimes provided with a resistor in parallel with the reactor. This combination is equivalent to a reactor and capacitance in series with a resistance, the value of which is low for low frequencies and high for high frequencies. Thus, the combination not only provides a low-impedance path for the selected frequency but because of the high resistance prevents amplification of the harmonics at the higher frequencies.

Rectifier a-c shunt filters are sometimes used to prevent the operation of the rectifier from increasing the harmonics in the a-c supply system. A-c filters are of two types, the non-tuned filter shown schematically in Fig. 31 and the tuned-frequency filter shown schematically in Fig. 32. The non-tuned filter consists of a reactor in series with the supply, and a shunt capacitor for each phase. Usually the addition of the reactor is objectionable from the regulation

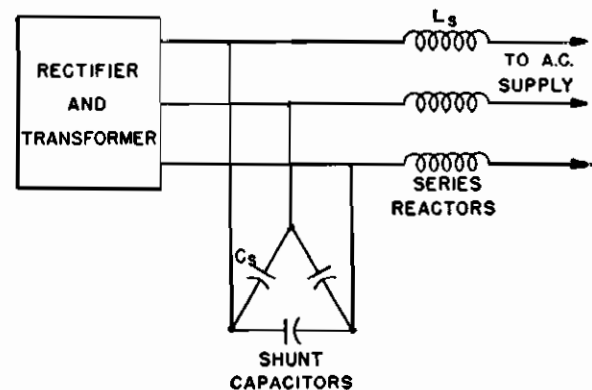

Fig. 31—Non-tuned a-c filter for use with small rectifiers—schematic diagram.

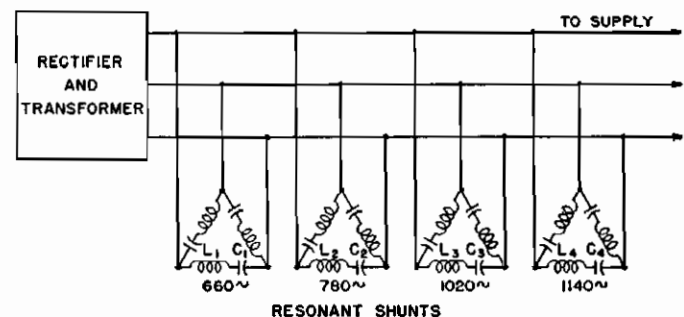

Fig. 32—Four-frequency tuned a-c shunt filter for use with large power rectifiers—schematic diagram.

standpoint for all but small rectifiers or installations such as certain types of broadcasting stations where induction regulators are commonly used. The combination of series reactor and shunt capacitor is usually proportioned so that the natural frequency is less than the lowest frequency produced by the rectifier, that is, lower than 300 cycles. In determining the effectiveness of the non-tuned filter, it is necessary to estimate the harmonic voltage impressed on the supply circuit for all of the important rectifier harmonics using the methods previously discussed in connection with rectifiers.

For most power applications the only permissible type of a-c filter consists of tuned shunts as illustrated in Fig. 32 for four frequencies. Shunt filters usually consist of four to seven elements, proportioned to accomplish different reductions in the harmonic voltages impressed on the supply circuit by the operation of the rectifier. In general, a filter design should be worked out only after full information is available as to the harmonics and frequency-impedance characteristics of the power source as viewed from the filter location. Usually this information is obtainable only after a rectifier is installed. If preliminary study of a rectifier installation indicates that a coordination problem is likely to be encountered and that an a-c filter in the power circuit is likely to be a remedial measure that should receive consideration, an estimate of the filter cost should be obtained from the manufacturer before the purchase of the rectifier equipment so that it will be available in studies relating to the cost of the complete installation. The Electrical Equipment Committee of the Edison Electric Institute in its "Report on Rectifier Wave Shape"¹⁵ recommends for the purpose of such a preliminary estimate, when the supply frequency is 60 cycles, that the characteristics of the filtering equipment be taken as follows:

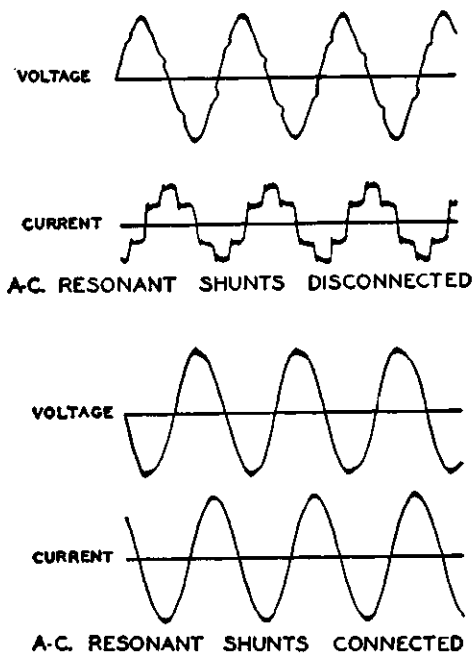

Fig. 33—The a-c line-current and voltage wave shapes of a six-phase rectifier without and with an a-c shunt filter.

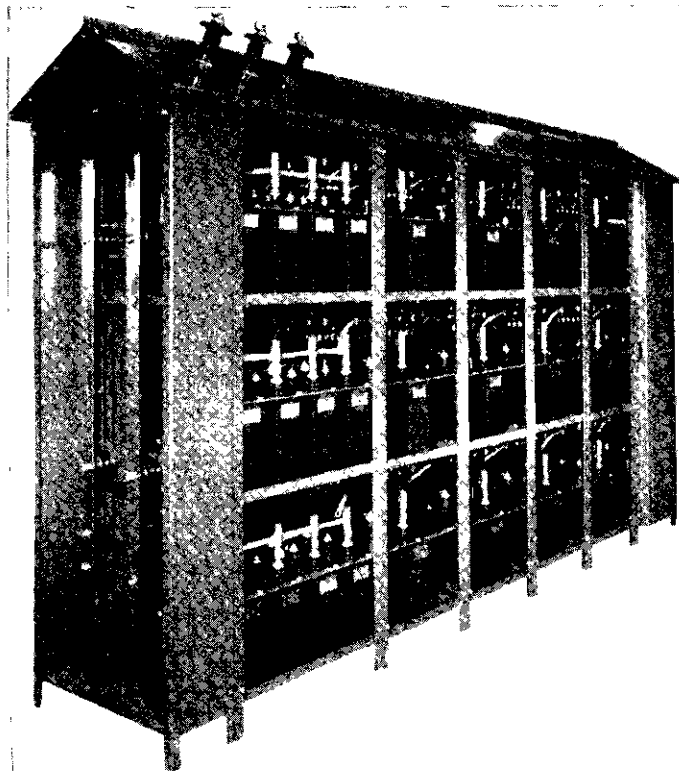

Fig. 34—Six-element a-c shunt filter for power rectifier. The shunts for each phase are arranged in horizontal rows and for each frequency in vertical rows.

"A-c Side. For either a 6-phase or 12-phase rectifier a device to limit the total contribution to the voltage T.I.F. to 20 for the combined effects of the frequencies corresponding to the 11th, 13th, 17th and 19th harmonics."

Rectifier filters can accomplish a very marked improvement in the voltage and current wave shapes of the supply circuit as illustrated in Fig. 33 by the redrawn oscillogram of the actual test results obtained on the first tuned-shunt filter ever built¹³. The general appearance of a shunt filter is illustrated in Fig. 34 for a six-frequency 4000-volt unit. Shunt filters are inherently relatively expensive and should not be considered as a normal part of a rectifier. In any particular case, consideration should also be given to alternative methods, such as:

1. The use of the largest number of phases consistent with the number of anodes required.
2. Rearrangement of power supply or location of feeders so as to avoid exposure.
3. A combination of other methods in the power or communication circuit in the same manner as used for other coordination problems.

D-c filters for rectifiers are much less expensive and complicated than a-c filters. The application of d-c filters is usually restricted to rectifiers which supply propulsion circuits with one side grounded. Normally d-c filters consist of a series reactor and three tuned-shunt elements as illustrated in Fig. 35. This combination operates to reduce the d-c harmonic voltages impressed on the external circuit by consuming them in voltage drop in the rectifier and

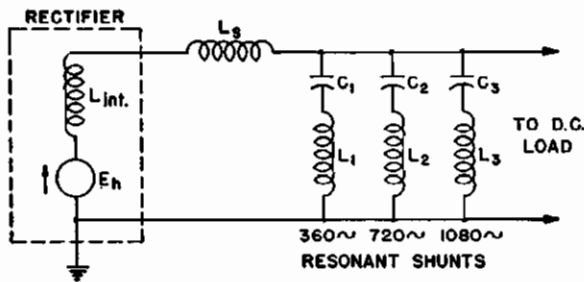

Fig. 35—Schematic diagram of a typical d-c filter for a rectifier.

transformer*, and in the series reactor. The reactor in the d-c circuit usually is of the iron-core type with air gap, mounted in a tank and frequently arranged for outdoor installation. The shunt elements should be so located and installed as to have very short leads, the length of which must be measured between the points through which all the direct current flows. If the filter leads are of considerable length they will reduce its effectiveness and upset tuning. The characteristics of d-c filtering equipment have been pretty well standardized and the recommendations in the E.E.I. Report on Rectifier Wave Shape¹⁵ for preliminary estimating purposes, when the supply frequency is 60 cycles, are as follows:

“D-c Side. For a 6-phase rectifier a device to give a 10 to 1 reduction of the 6th, 12th and 18th harmonic voltages. For a 12-phase rectifier a device to give a 5 to 1 reduction of the 6th and 18th harmonics and a 10 to 1 reduction of the 12th harmonic voltage.”

The foregoing reductions are based on calculated values assuming a load circuit of infinite inductance. These recommendations give considerable attention to the 360-cycle component on the basis of the presence of lower-impedance party line ringing equipment on telephone circuits. Where this type of ringing equipment is not used, it may be permissible to apply a simpler filter consisting of a large series reactor and a single shunt tuned for a frequency of approximately 1000 cycles. For higher d-c voltage systems and close exposures it may be desirable to provide an element for the 24th harmonic frequency.

12. Coupling Factors for Noise-Frequency Induction

The coupling factors for electric and magnetic induction at noise frequencies may be computed with a slight modification of the methods given in the section on low-frequency coupling. The electric coupling factors can be used directly both for metallic circuits and for those involving ground return. The magnetic coupling factors are proportional to frequency but for ground-return circuits it is necessary to introduce a different equivalent depth of return current, which can be calculated with the aid of Eq. (5). In telephone-noise calculations the coupling factors are based on a 400-foot equivalent depth of earth-return current. Some approximate coupling factors are given in Sec. 14, Calculation of Noise on Telephone Circuits.

Relative Location of Circuits—Frequently, by exchange of notice of intention to construct new facilities

*See Eq. (29).

and by cooperative advance planning, it is possible to avoid coordination problems that otherwise would arise. Close irregular parallels, as in overbuilt construction, are particularly to be avoided as this greatly decreases the effectiveness of transpositions. Where parallels have been created without consideration from the standpoint of advance planning, relocation often provides the best remedial measure.

Transpositions†—Probably the most important method for reducing noise-frequency inductive effects is obtained by transpositions, particularly transpositions in telephone circuits. A telephone circuit is said to be transposed when the two sides of the circuit reverse their respective positions at suitable intervals throughout its length. Transpositions are applicable principally to uniform exposures, and their effectiveness is greatly reduced when the separation is not uniform and when transpositions are not located at theoretically correct points. Transpositions are required in telephone circuits to avoid crosstalk and they are also effective in reducing noise-frequency induction from power circuits. The different functions of transpositions within an exposure section are shown in Table 11. This table shows that there are eight

TABLE 11—FUNCTIONS OF TRANSPOSITIONS WITHIN EXPOSURES

Source of Induction In Power Circuit	Direct	Indirect
	Metallic Induction	Metallic Induction
Balanced Voltages	T	P
Balanced Currents	T	P
Residual Voltages	T	*
Residual Currents	T	*

T—Telephone-circuit transpositions reduce these components of induction.

P—Power-circuit transpositions reduce these components of induction.

*—No effect on these components of induction except as they reduce the residuals themselves.

possible sources of noise-frequency induction from a power circuit; four of these result from the direct metallic-circuit induction caused by the balanced and residual components of voltage and of current, and four result from the indirect effect of longitudinal-circuit induction acting on the unbalances of the telephone circuit. Figures 2 and 3 show that unequal voltages may be induced in the two sides of a telephone circuit as a result of induction from both balanced and residual components of voltage and current. These unequal voltages can be resolved into metallic- and longitudinal-circuit components as illustrated in Figs. 4 and 5. It follows, therefore, that transpositions in the telephone circuit will reduce the resultant voltage in the metallic circuit. In a similar manner it can be shown that transpositions in a power circuit reduce the resultant metallic-circuit induction in an untransposed telephone circuit. However, in the practical case the telephone circuits are transposed frequently and the power-circuits infrequently, and the transposition points for the latter are usually located at neutral points on the telephone-circuit transposition system. Under these conditions power-circuit transpositions reduce only the indirect metallic-circuit induction resulting from longitudinal voltages acting on circuit unbalances. Transpositions in the power

†Reference 16 and Engineering Report No. 36 of Reference 4.

construction with newly-created parallels, a scheme known as "whole-line transpositions" has been developed, as illustrated in Fig. 36 (b). The whole-line transposition permits the accurate or approximate balance of the transposition system for the exposure section, but, of course, requires additional transpositions.

In connection with transposition systems, the question naturally arises as to the number that should be used. While some gain is possible by adding transpositions to those normally employed in transposition systems, it is important to recognize that the effectiveness of transposition depends on the uniformity of exposure, the accuracy of location of the transposition points, and the coordination of the transposition system with respect to the power-circuit exposure. These considerations make a definite limit to the number of transpositions that can be used effectively. The amount of reduction in metallic-circuit noise caused by the addition of transpositions is shown in Table 12 taken from the work of the E.E.I. and

TABLE 12—EFFECTIVENESS OF TELEPHONE TRANSPOSITION IN REDUCING METALLIC-CIRCUIT NOISE

Transpositions	Relative Noise In Side Circuits of Phantom Group		
	Min.	Ave.	Max.
Coordinated	1.2	6.	12.
Uncoordinated	8.8	25.	50.
None	50.0	100.	190.

Bell System*. Where a small number of circuits are involved, as for example in the case of a single power-company telephone line, it is possible to obtain a higher degree of effectiveness of transposition than indicated in the table. However, for transpositions applied to many circuits under the usual conditions of installation with some variation in separation, it is necessary to assume much lower effectiveness. Certain recommendations in this connection are given in Sec. 14, Calculation of Noise in Telephone Circuits.

13. Noise-Frequency Susceptiveness Factors

The principal noise-frequency susceptiveness factors on a telephone circuit are power-level and sensitivity, balance, and frequency-response characteristics. These vary with the type of communication circuit.

Power Level and Sensitivity—Noise-frequency coordination problems are always simplified if the ratio of induced or noise currents to speech currents are decreased. This may be done by decreasing the induced currents by control of influence or coupling factors, as discussed in previous sections, or by increasing the speech currents by increasing transmitter output or by using amplifiers. The simplest example of this method of control is the familiar practice of raising the speech level into the transmitter so as to override the noise on a telephone circuit. Unfortunately, this simple measure encounters limitations because of voice distortion and fatigue that result if an effort

*Engineering Report No. 16 of Reference 4.

is made to maintain too high an energy level. However, the same result can be accomplished by improved transmitters, which in effect provide amplifying action in the device itself. Amplifiers can also be used to increase the speech level as is done on long-distance toll circuits. However, in some cases, amplifiers will increase induced currents as well as speech currents. Thus the amplifiers, in themselves, are not a remedial measure of value unless they provide a lower ratio of noise to speech levels. Another factor to be considered is crosstalk since amplifiers may increase the crosstalk level from adjacent circuits. An increase in the energy level to overcome noise on one circuit may require corrective measures in many circuits because of crosstalk from circuits located on the same pole line. From the foregoing discussion it becomes apparent that for commercial communication systems, increasing the power levels rarely provides a feasible solution for a particular exposure. Instead, the most economical transmitters with the highest practical energy output are employed and the applications are made on the basis of the overall communication problem including crosstalk and noise.

For power-line communication systems and other isolated circuits, increased power levels may provide a coordination measure of value. Thus, audio-frequency amplifiers can be used to increase the voice-current output of the transmitter in combination with receivers of decreased sensitivity giving the same resultant receiver output. The amplifier is a relatively inexpensive remedial measure but requires maintenance and a source of energy. Thus, this type of remedial measure is more suitable for communication systems connecting two principal stations than for those that supply circuits with many intermediate taps as, for example, a patrol line. In general, more extensive use of amplifiers on power-line communication systems for reducing noise than is now general practice would be advantageous.

Balance of a Telephone Circuit—The balance of a telephone circuit or the symmetry of the two wires of a metallic circuit or of the four wires of a phantom circuit with respect to each other and to all other wires and to ground is a factor of great importance from the standpoint of noise when the circuits are located in powerful electric or magnetic fields. If the circuits are unbalanced, induced currents are produced which cause unequal drops in the different wires and thus impress a differential voltage on the metallic circuit; the result is noise in connected telephone receivers. Unequal conductor resistance, particularly high-resistance joints, may contribute importantly to the noise problem. Similarly, unsymmetrical capacitance coupling with other circuits may also be a factor of importance. Ordinarily telephone-circuit transpositions insure adequate conductor symmetry so that no special attention to this point is required other than maintenance to avoid high resistance joints or leaks to ground.

Another source of unbalance may exist in telephone-office or subscriber equipment. Some of these unbalances are inherent in standard equipment, particularly of the older types. One of the principal sources of unbalance is produced on party-line systems. One type of set uses a ringer of about 20,000 ohms impedance at 1000 cycles at

subscriber premises connected between one conductor and ground. These ringers offer a relatively low impedance to ground, particularly at the frequencies below 300 cycles and since the ringers are not located symmetrically on the circuit they are sometimes a source of important unbalances. Several remedies have been used, one of which consists in replacing the lower-impedance ringer by a higher-impedance device (about 165,000 ohms at 1000 cycles). Another measure uses ringing equipment at subscriber premises that is connected to the circuit by a tube only when the circuit is being used for ringing purposes. By this means the party-line circuit is not unbalanced under talking conditions. In the newer types of sets these unbalances are minimized.

Quite frequently an exposure will involve only a short parallel, although the telephone circuit itself is long. Unbalances in the telephone circuit outside of the exposure section may contribute importantly to the total telephone noise. This source of trouble can frequently be avoided by installing a repeat coil in the ends of the exposure section, thus effectively isolating the two sections of the circuit. The addition of the repeat coil, of course, introduces some transmission loss and interferes with telegraph use and with telephone-circuit testing, and therefore, can be justified only in special cases.

Frequency Response—In modern high-quality voice-frequency communication systems it is necessary to provide reasonably good response over the frequency range of from about 200 to 3500 cycles, the range that also covers the principal harmonic frequencies of power systems. The older types of receivers produce the effect of resonance in the vicinity of 1100 cycles. For this reason the use of filters in telephone circuits to block the flow of induced current of a particular power-system frequency has often been proposed. However, experimental studies by power and communication companies have shown that such a method of solution is only rarely practical. In the future this method should be of still less value because the trend in communication circuit equipment is toward more uniform response and a wider frequency band.

On rural telephone lines there are frequently high magnitudes of low-frequency induction. These situations can often be improved by reducing the low-frequency response²⁵. For example, with the commonly-used connection for a local battery telephone set, the receiver can be shunted by a 60-millihenry coil and a 0.75 mf capacitor placed in series with the receiver. Another arrangement is to reconnect the set placing the receiver with a 1-mf capacitor in series across the transmitter side of the induction coil. Such measures, while impairing the quality of voice reproduction, may provide an overall improvement in the order of 2:1 where the noise is confined to low frequencies.

Carrier-frequency communication systems are rarely affected by power-system harmonics because the harmonics in the carrier-frequency range are of small magnitude and the effects of the lower harmonics are minimized because of frequency separation.

Type of Circuit—The telephone circuit of maximum susceptibility to induction from a power circuit is the ground-return or rural telephone circuit. Practically all

such circuits are noisy when operated close to power circuits. The metallicizing of such ground-return circuits provides the most important measure for minimizing noise-frequency problems in such cases. Sometimes it is practical to metallicize only the exposure section by installing repeat coils between the exposure section and the remainder of the circuit. Separation of the two wires of a metallic circuit is, of course, an important factor in the problem. Conductors on open-wire telephone circuits are usually located 12 inches apart. The reduced spacing of eight inches has been found advantageous for carrier-frequency circuits. Table 13 shows the relative noise in subscriber

TABLE 13—RELATIVE NOISE IN SUBSCRIBER CIRCUIT EXPOSED TO SINGLE-PHASE COMMON-NEUTRAL POWER CIRCUIT

Item	Type of Service	Relative Noise*	
		One Set on Line	Two Sets on Line
1	Grounded Rural Line, 38B Ringer	1400-1800	1400-1800
2	Individual Line, 8A Ringer	1-10	
3	Party Line, Single-Condenser, 8A Ringer	45-55	40-60
4	Party Line, Single-Condenser, 8J Ringer	12-25	12-25
5	Party Line, Split-Condenser, 8A Ringer	12-25	4-12
6	Party Line, Split-Condenser, 8J Ringer	1-10	1-10

*Based on Engineering Report No. 6 of Reference 4.

sets for rural telephone lines, individual lines, and party lines with various types of ringing equipment.

Duplex conductors or telephone-drop leads have been found advantageous from the noise standpoint in particular situations. The close spacing and twisting of the conductors minimize the possibility of unequal voltages being induced in the two wires. However, these insulated conductors increase transmission loss and are likely to develop leakage unbalances as the insulation deteriorates. Consequently, duplex or similar conductors are impractical as a remedial measure, except for short lengths or for conductors that are intended for short-time service.

Cables provide an important factor in the simplification of noise-frequency coordination problems, particularly in the urban areas where exposures are severe. Cables provide the economical form of construction in many densely-populated districts. With grounded cable sheaths the inductive effects from voltages are negligible. If the cable sheath is grounded at both ends through low-impedance connections, the noise problem from currents is reduced. In cable circuits the principal factor is the indirect metallic-circuit noise resulting from cable unbalances and the induced longitudinal voltages produced by residual currents. Usually, however, cables are relatively well transposed and balanced so that the important unbalances are those caused by central-office cord circuits and by subscriber ringing equipment.

14. Calculation of Telephone-Circuit Noise*

The estimation of telephone-circuit noise resulting from power-circuit induction is an involved procedure. It is possible here only to indicate the general philosophy of telephone-noise calculations and to provide simple formulas useful primarily for indicating order of magnitude of the noise problem in a typical situation.

The general procedure in calculating telephone-circuit noise is to obtain power-circuit harmonic voltages and currents and to resolve these into balanced and residual components. Then the harmonic voltages impressed on the telephone-circuit conductors are calculated with the aid of coupling factors based on the geometry of the circuits, and for residual circuits the equivalent depth of earth-return current for harmonic frequencies. The voltages impressed on the telephone-circuit conductors are then resolved into metallic- and longitudinal-circuit components. For a balanced but untransposed circuit, the noise-frequency currents in the telephone receiver resulting from the metallic-circuit components of induced voltages are readily calculated. Longitudinal voltages impressed on a perfectly balanced circuit cause no current in connected telephone receivers. However, when either series or shunt unbalances are present, longitudinal induced voltages acting upon them produce additional noise-frequency currents in the telephone receivers.

The noise-frequency currents in the telephone receiver, which are obtained by the preceding calculations, are then converted to noise units with the aid of suitable conversion factors. Reference noise has been standardized at 10^{-12} watts at 1000 cycles, which corresponds to 0.0408 micro-amperes on 600-ohm circuits, and to approximately seven noise units for noise measured on the line†.

Telephone circuit noise is frequently expressed in decibels (db). In the decibel scale the ratio of two voltage- or two current-quantities is expressed,

$$\text{Ratio in db} = 20 \log_{10} \text{Ratio} \quad (33)$$

Thus, telephone noise when expressed in db is the ratio to reference noise taking reference noise as seven noise units. Thus, telephone line noise is

$$\text{Noise in db} = 20 \log_{10} \frac{\text{Noise Units}}{7} \quad (34)$$

A convenient figure to remember is that a change of six decibels corresponds to a change of 2:1 in voltage or current ratios. Table 14 gives a list of decibel and current- or voltage-gain ratios and corresponding relation to noise units.

The foregoing discussion applies directly for induced currents of a single frequency. Where several harmonics

Extensive discussions of telephone-noise calculations are given in the Engineering Reports of the Joint Development and Research Subcommittee, Edison Electric Institute and Bell Telephone System, particularly No. 16 for open-wire toll circuits, No. 17 for open-wire subscriber circuits at roadway separation, No. 13 for open-wire subscriber circuits in joint-use situations, No. 9 for subscriber circuits in cable, and No. 40 for ground-return or rural telephone circuits.

†Reference noise based on receiver currents is 14 noise units.

TABLE 14—DB RATIOS—RELATION TO GAIN RATIOS AND NOISE UNITS

Db	Voltage or Current Gain Ratio*	Approximate Noise Units (Based on Line Noise)
0	1	7
6	2	14
10	3.16	22
15	5.62	40
20	10.00	70
25	17.80	125
30	31.6	220
35	56.2	400
40	100.	700
45	178.	1250
50	316.	2200
60	1,000.	7000
80	10 000.
100	100 000.

*Attenuation Ratios are reciprocal of Gain Ratios.

are present, the resultant noise is estimated by combining the individual noises according to the sum of the squares of the individual components. However, as a practical matter, the harmonics in the power system are replaced by an equivalent harmonic that can then be used with suitable coupling factors and with telephone-circuit impedances to give the equivalent noise-frequency current in the telephone receiver. This is essentially the inverse of the process discussed in Sec. 10 for the determination of power-circuit voltage and current T.I.F.'s. In fact, the T.I.F. weighting curve can be used with a coupling factor varying directly with frequency and equal to unity at 1000 cycles to obtain the telephone-receiver weighting curve. When transpositions are present, as is usually the case, their effect can be estimated by a suitable factor. When there are unbalances outside of the exposure section, this circumstance must also be taken into account.

The preceding discussion shows that accurate noise calculations are complex. Fortunately, an important simplification can be obtained by calculating (a) the longitudinal noise-frequency voltages and (b) the direct metallic-circuit noise. The longitudinal voltages are then used in connection with the circuit unbalances to obtain the metallic-circuit noise caused by unbalances. Empirical factors, known as the metallic-longitudinal ratios (M-L ratios) are applied to the longitudinal noise-frequency voltages to obtain the metallic-circuit noise. Further simplification is obtained by considering only the direct metallic-circuit induction component, taking into account at the same time the reduction resulting from transpositions. Formulas for calculating the direct metallic-circuit noise are given below. This is illustrative of other methods and is more accurate when the effect of unbalances are relatively unimportant. This method also gives the best physical picture of the problem and is useful in indicating the severity of a noise problem.

The basic formulas for the calculation of metallic-circuit noise‡ are:

‡These formulas and the K factors of Fig. 37 are based on Engineering Reports Nos. 16 and 17 of Reference 4.

$$\left. \begin{aligned} NM_{E-B} &= K_{E-B}K_f(KV \cdot T_B) \\ NM_{E-R} &= K_{E-R}K_f(KV \cdot T_R) \\ NM_{I-B} &= K_{I-B}K_f(I \cdot T_B) \\ NM_{I-R} &= K_{I-R}K_f(I \cdot T_R) \end{aligned} \right\} \quad (35)$$

where NM_{E-B} , NM_{E-R} —metallic-circuit noise caused by electric induction from balanced or residual voltages—noise units.

NM_{I-B} , NM_{I-R} —metallic-circuit noise caused by magnetic induction from balanced or residual currents—noise units.

K_{E-B} , K_{E-R} —factors* giving ratio of metallic-circuit noise on telephone circuit to balanced or residual voltage on power-circuit in kv. See Fig. 37.

K_{I-B} , K_{I-R} —factors† giving ratio of metallic-circuit noise on telephone circuit caused by balanced or residual current to power-circuit amperes. See Fig. 37.

K_f —length of exposure in kilo-feet.
 KV —power-circuit voltage in kilovolts—fundamental frequency.
 I —power-circuit current in amperes—fundamental frequency.

$KV \cdot T_B$, $KV \cdot T_R$ —power-circuit voltage in kv from line to line multiplied by balanced voltage T.I.F.; corresponding $KV \cdot T$ factor for residual.

$I \cdot T_B$, $I \cdot T_R$ —power-circuit current in amperes multiplied by balanced or residual current T.I.F.

The K factors of Fig. 37 are based on horizontal distances in feet measured between nearest power and telephone conductors. In Fig. 37 the K factors for balanced voltages are plotted for symmetrical horizontal configuration; correction-factor multipliers for several other configurations and for different heights of power conductors are given in the tabulation included in the figure.

The noise resulting from several components of induction can be combined according to the following formula:

$$NM = \sqrt{(NM_{E-B})^2 + (NM_{E-R})^2 + (NM_{I-B})^2 + (NM_{I-R})^2} \quad (36)$$

This is an empirical law of combination but represents the only practical method for combining the effects, which may range from the arithmetic difference to the arithmetic sum of the quantities. The effect of reduction in noise resulting from transpositions may be estimated from Table 15.

The formulas of Eq. (35) do not take into account the beneficial action from mutual shielding of telephone-circuit conductors against electric induction. For this reason the values given will be somewhat high for a large number of telephone-circuit conductors insofar as the noise from induced residual voltage is concerned. These formulas do

* K_{E-B} and K_{E-R} are coefficients of electric induction in volts per kilovolt, multiplied by a constant of 0.077.

† K_{I-B} and K_{I-R} are coefficients of magnetic induction in microhenries per kilofoot, multiplied by a constant of 0.08.

TABLE 15—TRANSPOSITION REDUCTION FACTORS*

Coordination	Subscriber Circuit		Toll Circuit Average			
	Joint Use		Roadway Separation	Side	Phantom	Non-Phantom
	Non-Pole Pair	Pole Pair				
Optimum	0.1 to 0.2	0.05 to 0.1	0.05 to 0.1	0.06	0.3	0.025
Nominal	0.2 to 0.4	0.10 to 0.2	0.2	0.25	0.25

*From Engineering Reports Nos. 16 and 17 of Reference 4.

not take the effects of unbalance into account. These effects, which may be estimated from a knowledge of the unbalances, may be more important from the noise standpoint than the effects of direct metallic-circuit induction.

For joint-use situations, the constants K_{E-B} , K_{E-R} , etc., as given in Table 16 should be used. The effect of reduction in noise resulting from transpositions may again be estimated from Table 15.

Noise Evaluation—The impairment of telephonic transmission produced by a given line noise can be expressed in terms of an increase in the transmission loss of the circuit, which would cause an impairment of telephone service equal to that caused by the noise. With a knowledge of the costs which are involved in providing circuits to meet different standards of transmission, a judgment can be made as to the importance of noise in a given instance. This method of noise evaluation is used by Bell System Engineers²⁶. On toll circuits, line noise of 200 noise units (29 db above reference noise) produces negligible impairment. Many power-company telephone lines are operating under conditions producing more than 800 noise units and some considerably in excess of that figure. The permissible noise of a particular circuit cannot be stated definitely as it depends upon the margin of telephonic-transmission loss, the room noise conditions at the terminals, the nature of the telephone business transacted, i.e., whether individual message or written reports, the quality of the service to be given and the characteristics of the user.

TABLE 16—VALUES OF K_{I-B} , K_{I-R} , K_{E-B} AND K_{E-R} FOR OPEN-WIRE JOINT-USE EXPOSURES‡

Components	Outside Conductor Distances— inches	K_{I-B} and K_{I-R}		K_{E-B} and K_{E-R}	
		Non-Pole Pair	Pole Pair	Non-Pole Pair	Pole Pair
Balanced	15	0.077	0.15	0.16	0.36
	30	0.10	0.62	0.22	0.83
Residual	60-100	0.22	1.40	0.32	1.80
	Any	0.20	0.75	0.42	1.4

Above values apply to four-foot separation between power crossarm and nearest telephone crossarm. For six- and eight-foot separation, multiply K_{I-B} and K_{I-R} by 0.6 and 0.45 and K_{E-B} and K_{E-R} by 0.55 and 0.40, respectively.

‡Based on Engineering Report No. 13 of Reference 4.

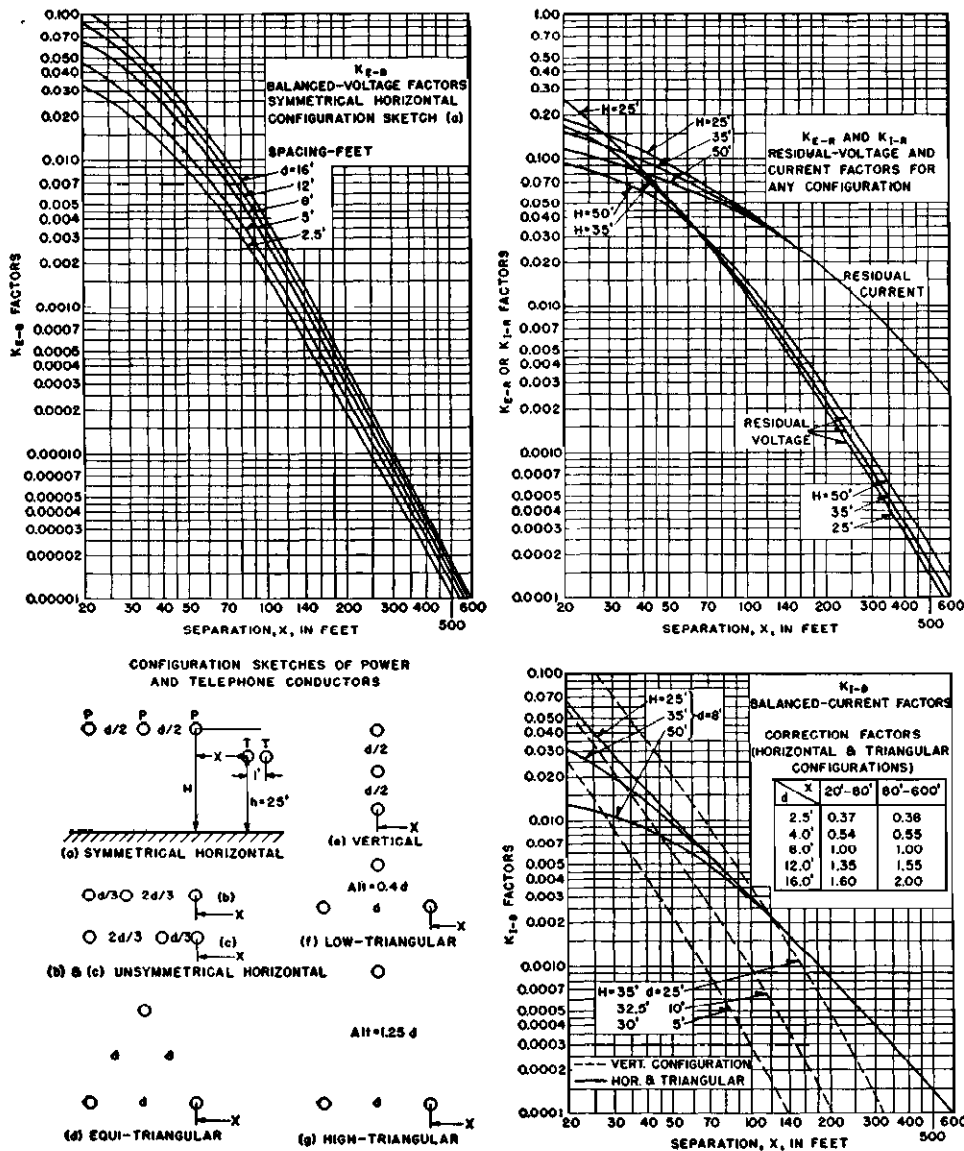

K_{E-B} —CONFIGURATION CORRECTION-FACTOR MULTIPLIERS. See Configuration Sketches (a) to (g).

X	(b) Horizontal		(c) Horizontal		(d) Equi-triangular					(e) Vertical				(f) Low-triangular					X
	5'	8'	5'	8'	2.5'	5'	8'	12'	16'	5'	8'	12'	16'	2.5'	5'	8'	12'	16'	
20'	1.13	1.05	0.77	0.91	1.08	1.19	1.03	1.05	1.01	1.04	20'
60'	1.35	1.24	0.74	0.77	0.69	0.95	0.94	0.92	1.07	0.45	0.35	0.28	0.30	0.85	1.09	1.04	0.99	1.20	60'
100'	1.38	1.34	0.68	0.76	0.72	1.01	1.10	1.15	1.21	0.70	0.58	0.53	0.55	0.68	0.92	0.96	0.97	1.14	100'
300'	1.43	1.40	0.74	0.75	1.08	1.44	1.81	2.23	2.34	1.68	1.91	2.20	2.33	0.38	0.66	0.93	1.23	1.75	300'
600'	1.50	1.46	...	0.65	1.53	1.96	2.57	3.02	4.05	2.25	3.01	3.62	4.28	...	0.49	0.82	1.32	2.09	600'

K_{E-B} —CONFIGURATION C.F.M. (Cont'd)

X	(g) High-triangular				
	2.5'	5'	8'	12'	16'
20'	1.40	1.34
60'	0.84	0.99	1.00	1.11	1.36
100'	0.90	1.18	1.23	1.25	1.24
300'	1.66	2.18	2.60	2.85	...
600'	2.21	3.07	3.85	4.06	...

K_{E-B} —HEIGHT CORRECTION-FACTOR MULTIPLIERS. See Configuration Sketch.

X	H	(a) (b) (c) Horizontal		(d) Equi-triangular		(e) Vertical		(f) Low-triangular		(g) High-triangular		H
		25'	50'	25'	50'	25'	50'	25'	50'	25'	50'	
20'	20'	1.55	0.21	1.20	0.67	0.80	0.75	1.48	0.21	1.20	0.67	20'
60'	60'	1.00	0.85	1.14	0.87	1.25	1.25	0.92	1.00	1.14	0.87	60'
100'	100'	0.90	1.06	1.15	0.93	1.50	0.72	0.88	1.20	1.15	0.93	100'
300'	300'	0.85	1.34	1.00	1.00	1.00	0.95	0.95	1.10	1.00	1.00	300'
600'	600'	0.83	1.34	1.00	1.02	1.00	1.05	1.00	1.03	1.00	1.02	600'

Fig. 37—Charts for the determination of K_{E-B} , K_{I-B} , K_{E-R} and K_{I-R} factors for use with noise formulas, Equations (35). In all cases telephone wires are assumed to be 1 foot apart and 25 feet above ground.

REFERENCES

1. Reports of Joint General Committee of National Electric Light Association and Bell Telephone System on Physical Relations between Supply and Signal System.
 - (a) "Principles and Practices for the Inductive Coordination of Supply and Signal Systems", December 9, 1922.
 - (b) "Principles and Practices for the Joint Use of Wood Poles by Supply and Communication Companies", February 15, 1926.
 - (c) "Inductive Coordination—Allocation of Costs between Supply and Communication Companies", October 15, 1926.
2. *Report of the American Committee on Electrolysis*, B. J. Arnold, Chairman (Published in book form in 1921).
3. Cathodic Protection of Underground Pipe Lines from Soil Corrosion, R. J. Kuhn, *American Petroleum Institute Proceedings*, pp. 153–165, October 1933.
4. *Engineering Reports of Joint Subcommittee on Development and Research*, National Electric Light Association (Edison Electric Institute), and Bell Telephone System.

Engineering Reports Nos. 1 to 8, vol. I, published March 1930.

Engineering Reports Nos. 9 to 15, vol. II, published April 1932.

Engineering Reports Nos. 16 to 25, vol. III, published January 1937.

Engineering Reports Nos. 26 to 38, vol. IV, published January 1937.

Subsequent reports published individually.
5. *Symmetrical Components*, C. F. Wagner and R. D. Evans, McGraw-Hill Book Company, New York, 1933.
6. Earth Resistivity and Geological Structure, R. H. Card, *Transactions A.I.E.E.*, p. 1081, 1935.
7. Calculation of Capacity Coefficients for Parallel Suspended Wires, F. F. Fowle, *Electrical World*, v. 58, pp. 386, 443, 493, August 12, 19 and 26, 1911.
8. Review of Work of Subcommittee on Wave Shape Standard of the Standards Committee, H. S. Osborne, *Transactions A.I.E.E.* Feb. 1919, p. 261.
9. Measurement of Telephone Noise and Power Wave Shape, J. M. Barstow, P. W. Blye, and H. E. Kent, *Transactions, A.I.E.E.*, pp. 1307–15, December 1935.
10. Generator Wave Shape, Joint Report of Electrical Apparatus Committee and Foreign System Coordination Committee of the National Electric Light Association, NELA Publication No. 239, 1932.
11. System Lower Harmonic Voltages—Methods of Calculation and Control by Capacitors, W. C. Feaster and E. L. Harder, *Transactions A.I.E.E.*, pp. 1060–6, 1941.
12. Inductive Coordination Aspects of Shunt Capacitor Installation, *Edison Electric Institute Bulletin*, pp. 382–3, 1938.
13. Harmonics in A-C Circuit of Grid-Controlled Rectifiers and Inverters, R. D. Evans and H. N. Muller, Jr., *Transactions A.I.E.E.*, pp. 861–8, 1939.
14. Output Wave Shape of Controlled Rectifiers, F. O. Stebbins and C. W. Frick, *Transactions A.I.E.E.*, pp. 1259–65, 1934.
15. Rectifier Wave Shape Report, Report of the Electrical Equipment Committee of the Edison Electric Institute, Publication No. E-1, April 1937.
16. Inductive Coordination with Sodium Lighting Circuits, H. E. Kent and P. W. Blye, *Transactions A.I.E.E.*, pp. 325–333, 1939.
17. The Design of Transpositions for Parallel Power and Telephone Circuits, H. S. Osborne, *Transactions A.I.E.E.*, p. 897, 1918.
18. Symposium on Coordination of Power and Telephone Plant, *Transactions A.I.E.E.*, pp. 437–477, 1931.

Trends in Telephone and Power Practices as Affecting Coordination, W. H. Harrison and A. E. Silver.

Status of Joint Development and Research on Noise-Frequency Induction, H. L. Wills and O. B. Blackwell.

Status of Joint Development and Research on Low-Frequency Induction, R. N. Conwell and H. S. Warren.

Status of Cooperative Work on Joint Use of Poles, J. C. Martin and H. L. Huber.
19. *Inductive Coordination*, L. J. Corbett (a book), The Neblett Pressroom Ltd., San Francisco, Calif., 1936.
20. Inductive Coordination of Common-Neutral Power-Distribution Systems and Telephone Systems, J. O'R. Coleman and R. F. Davis, *Transactions A.I.E.E.*, pp. 17–26, 1937.
21. Protective Features for the Joint Use of Wood Poles Carrying Telephone Circuits and Power-Distribution Circuits Above 5000 Volts, J. O'R. Coleman and A. H. Schirmer, *Transactions A.I.E.E.*, pp. 131–40, 1938.
22. Coordination of Power and Communication Circuits for Low-Frequency Induction, J. O'R. Coleman and H. M. Trueblood, *Transactions A.I.E.E.*, pp. 403–12, 1940.
23. Control of Inductive Interference to Telegraph Systems, J. W. Milnor, *Transactions A.I.E.E.*, pp. 469–75, 1940.
24. Neutralizing Transformers to Protect Power-Station Communication, R. K. Honaman, L. L. Lockrow, E. L. Schwartz and E. E. George, *Transactions A.I.E.E.*, pp. 524–9, 1936.
25. Noise Coordination of Rural Power and Telephone Systems, H. W. Wahlquist and T. A. Taylor, *Transactions A.I.E.E.*, pp. 613–21, 1938.
26. Evaluating Effects of Line Noise on Telephone Transmission. *N.E.L.A. Bulletin*, p. 779, December 1930.

CHARACTERISTICS OF DISTRIBUTION LOADS

Author:

H. L. Willis

A T&D system exists to deliver power to electric consumers in response to their demand for electric energy. This demand for electricity, in the form of appliances, lighting devices, and equipment that use electric power, creates *electric load*, the electrical burden that the T&D system must satisfy. In a de-regulated power industry, quality of service – basically quality in meeting the customers’ needs – is paramount. Quality begins with a detailed understanding of the customer’s demand requirements, and includes the design of a system to meet those needs. This chapter discusses electric load and presents several important elements of its behavior that bear on T&D system engineering aimed at satisfying those requirements as economically as possible.

I. ELECTRICAL LOADS

1. Consumers Purchase Electricity for End Use Application

Electricity is always purchased by the consumer as an intermediate step towards some final, non-electrical product. No one wants electric energy itself, they want the products it can provide: a cool home in summer, a warm one in winter, hot water on demand, cold beverages in the refrigerator, and 48 inches of dazzling color with stereo commentary during Monday-night football. Different types of consumers purchase electricity for different reasons, and have different requirements for the amount and quality of the power they buy, but all purchase electricity as a way to provide the end-products they want. These various products are called *end-uses*, and they span a wide range, as shown in Table 1.

TABLE 1—CUSTOMER CLASSES AND END-USE CATEGORIES

Agricultural	Residential	Commercial	Industrial
Lighting	Lighting	Lighting	Lighting
Water heating	Water heating	Water heating	Water heating
Space heating	Space heating	Space heating	Space heating
Air conditioning	Air conditioning	Air conditioning	Air conditioning
Computer	Computer	Computer	Computer
Air circulation	Air circulation	Air circulation	Air circulation
Cooking	Cooking	Cooking	Filtration
Water well pump	Water well	Elevators	Fluid pumps
Grain dryers	Clothes dryers	Inventory System	Finishing dryers

Some end-uses are satisfied only by electric power (televisions, computers). In others, electricity dominates in usage over other alternatives (there *are* gasoline-powered refrigerators, and natural gas can be used for lighting). But for many end-uses, such as water heating, home heating, cooking, and clothes drying in the residential sector, and pulp heating and tank pressurization in the industrial sector, electricity is but one of several possible, competing energy sources.

2. Power Systems Exist to Satisfy Customers, Not Loads

The traditional manner of representing customer requirements for power system engineering has been as aggregate electric loads assigned to nodes for electrical design. For example, customer needs in an area of a city may be estimated as having a maximum of 45 MW. That value is then assigned to a particular bus in engineering studies aimed at assuring that the required level of power delivery can be provided by the system.

Traditionally, the engineering methods used in those design studies have been system-based: performance and criteria are evaluated against the power system itself, not against the customers’ needs. Equipment loading limits, single-contingency backup criteria, and voltage drop/power factor guidelines defined on the distribution system and even at the customer meter point, all view electrical performance from the system perspective, and do not directly address customer needs.

Such engineering methods, while necessary to tailor many aspects of T&D design, are not sufficient to completely address the maximization of customer value. Power systems exist to satisfy customers, not loads. Understanding the specific needs of the customers – how much *quality* they require in power delivery as well as the *quantity* of power they need – can improve the *value* provided by the power system. The “two Qs” – quantity and quality – both need to be considered in designing and operating a power system to provide maximum customer value.

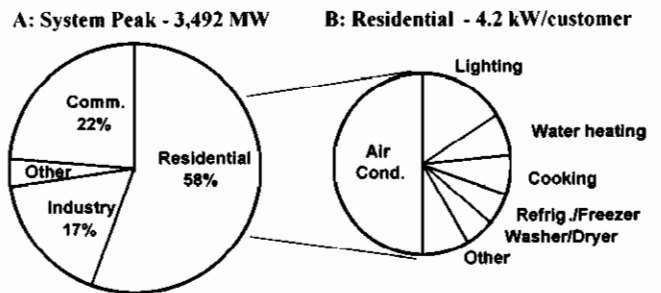

Fig. 1—Left: peak electric demand for a power system in the southern United States, broken out by customer class. Right: within the residential class, which accounts for 58% of the system peak, per capita usage at peak conditions falls into the end-use categories as shown.

End-use analysis of electric load – the study of the basic causes and behavior of electric demand by customer type and end-use category – is generally regarded as the most effective way to study consumer requirements from the standpoints of quantity, quality, and schedule. In any one household,

business, or factory, the various individual end-use loads operate simultaneously, forming the composite load, as depicted in Fig. 1B. The T&D system sees this composite load through the meter as a single load. In aggregate, the loads of all customers produce the system load (Fig. 1A), with each type or class of customer contributing a portion to the overall system demand.

The amount of electric load created on a power system within any end-use category, for example residential lighting, depends on a number of factors, beginning with the basic need for lighting. People or businesses who need more lighting will tend to buy more electricity for that purpose. Also important are the types of appliances used to convert electricity to the end-use. Consumers using incandescent lighting rather than fluorescent lighting will use appreciably more electric power for otherwise similar end-uses.

The schedule of demand for most end-uses varies as a function of time. In most households, demand for lighting is lowest during mid-day and highest in mid-evening, after dusk but before most of the residents have gone to bed. The daily schedule of lighting demand usually varies slightly throughout the year, too, due to seasonal changes in the daily cycle of sunrise and sunset. Some end-uses are only seasonal. Demand for space heating occurs only during cold weather. Peak demand for heating occurs during particularly cold periods, usually in early morning, or early evening, when household activity is at its peak.

The quality of the electric power supplied is more critical to some end-uses than to others. A power system that can provide the quantity of power required may still not satisfy the consumers, either because it does not provide sufficient availability of power (reliability), or because it does not provide sufficient voltage regulation or transient voltage performance (surges, sags). Reliability and voltage regulation needs vary from one end-use to another, as will be discussed later in this chapter, and depends mostly on the value of the end-use to the customer.

The value that consumers place on any particular end-use is a function of its importance to their quality of life, or to the productivity of their factory or commercial business. An important (but for many power engineers, counter-intuitive) concept is that end-use value is not of a function of the cost of the electric power. For example, most personal computers and workstations use only 2-3¢ worth of power per hour, yet users typically report that an hour's interruption due to lack of power has a cost of a dollar or more.

Cost is a major factor in T&D design. In fact, cost is often a consumer's primary concern, for which they are willing to accept major compromises in quality, and quantity, or service. The challenge facing T&D engineers is to meet consumer needs for both "Qs" – quantity and quality – at the lowest possible cost. Building a system that delivers higher reliability levels than customers need is exactly the same as building one that can deliver much more power than they need.

Knowledge of the customer needs for quantity and schedule of power delivery, and of the value they place on reliability, voltage regulation, surge and sag protection, and other factors, are important factors in modern power factor design, as is an

understanding of how customer loads interact with the power system. Most critical, however, is simply the act of keeping in mind that the "electric loads" used in T&D engineering studies represent the energy needs of people using electricity. The best power system is one that satisfies their needs as economically as possible.

II. CUSTOMER ELECTRIC LOAD BEHAVIOR

3. Connected Load

The *connected load* is the sum of the full load (nameplate) continuous ratings of all electrical devices in the composite load system. A typical household in a developed country might have a 4,000-watt water heater, a 1,000-watt water-well motor, a 5,000-watt central air conditioner, a 6,500-watt space heater, thirty lighting fixtures or lamps with an average load of 100 watts each, a 4,000 watt cooking range, a 3,500 watt clothes washer/dryer, a 500 watt refrigerator, and 2,500 watts of miscellaneous home entertainment, personal grooming, and other small appliances, for a total of 30,000 connected watts of load. Whether all or any of these are operating at any one time depends on a number of factors, including the demand for their various end-use products. It is rare that all the connected load in a system or at any one customer's location would be operational at one time (for example, air conditioning and heating would not be running simultaneously).

4. Electric Load Curves

Use of the products created by electric power – light, heat, hot water, images on the TV, and so forth, varies as a function of time of day, day of week, and season of year. As a result, the electric load varies. A *load curve* plots electric consumption as a function of time. Fig. 2 shows seasonal peak day load curves for residential loads from two electric systems in the United States. In one system, demand is highest in summer, during early evening, when a combination of air conditioning demand and residential activity is at a peak. In the other, peak demand occurs on winter mornings, when an electric heating demand is highest.

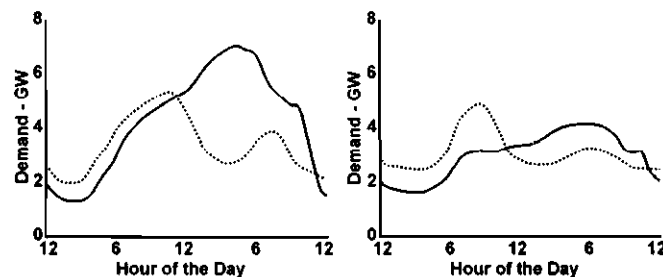

Fig. 2—Typical summer (solid line) and winter (shaded line) peak day load curves for a metropolitan power system in the southern US (left) and a rural system in New England (right).

Load curve shape – when peak load occurs and how load varies as a function of time – depends both on the connected load (appliances) and the activity and lifestyles of the

consumers in an area. Differences between the electric demand patterns of otherwise similar types of customer (as in Fig. 2) occur because of differences in climate, demographics, appliance preferences, and local economy.

5. Demand

Demand is the average value of load over a period of time known as the *demand interval*. Often, demand is measured on an hourly or quarter-hour basis, but it can be measured on any interval – seven seconds, one minute, 30 minutes, daily, monthly, annually. The average value of power, $p(t)$ during the demand interval is found by dividing the kilowatt-hours accumulated during the interval by the number of hours in the interval.

Demand is the average of the load during the interval. The peak and minimum usage rates during the interval may have been quite different from this average (Fig. 3). Demand intervals vary among applications, but commonly used interval lengths are 5, 15, 30, and 60 minutes.

Peak demand, the value often called “peak load,” in design studies, is the maximum demand measured over a billing or measurement period. For example, a period of 365 days contains 35,040 fifteen-minute demand intervals. The maximum among these 35,040 readings is the peak fifteen-minute demand. This value is often used as the basis for an annual demand charge if the readings measure a single customer’s usage, and as a capacity target in engineering studies: the maximum amount the system must deliver.

6. Demand Factor

The *demand factor* of a system is expressed as the ratio of maximum demand to the connected load. Normally the demand factor is considerably less than 1.0.

7. Load Factor

Load factor is the ratio of the average demand to the peak demand during a particular period. Load factor is usually determined by dividing the total energy (kilowatt hours) accumulated during the period by the peak demand and the number of demand intervals in the period, as

$$LF = \frac{\text{Total usage during period}}{(\text{Peak Demand}) \times m} \quad (1)$$

where m = number of demand intervals in period

$$LF = \frac{\text{Average Demand}}{\text{Peak Demand}} \quad (2)$$

Load factor gives an indication of the degree to which peak demand levels were maintained during the period under study. Load factor is typically calculated on a daily, monthly, seasonal, or an annual basis.

8. Power Factor

All loads require real power – kilowatts – to perform useful work such as mechanical rotation or illumination. Reactive loads also require reactive volt-amperes (VAR) to do a type of

“non-productive work” required for their function, such as produce the magnetic field inside a transformer or motor, without which they can not function.

VAR flow on a power system consumes capacity in conductors, transformers, and other equipment, but provides no useful “real” work. It is mitigated by the use of capacitors and other devices, or by changes in the end-use device so that it consumes fewer VARS (see Chapter 8).

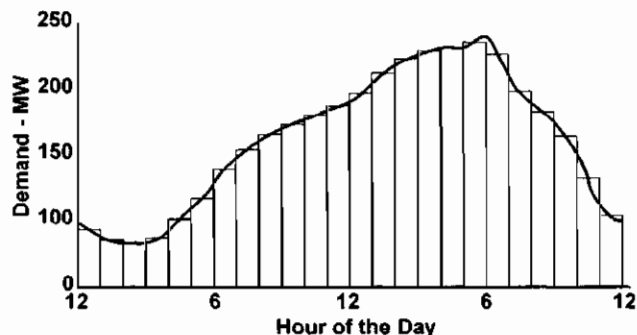

Fig. 3—Demand on an hourly basis (blocks) over a 24 hour period. Continuous line indicates demand measured on a one-minute interval basis. Maximum one-minute demand (at 5:52 PM) is about 4% higher than maximum one-hour demand (5-6 PM).

9. Voltage Sensitivity of Loads

The various electrical appliances connected to the power system exhibit a range of different load vs. voltage sensitivities. Important characteristics include their response to transient voltage changes and their steady state load vs. voltage behavior.

Transient voltage response is difficult to characterize and if important, should be modeled with detailed, and specific, study of the transient response of the particular loads involved. Classification of transient load response into categories is useful in some cases, but no simple generalization works in all cases.

For “steady state” representation, individual electric loads are generally designated as falling into one of three categories depending on how they vary as a function of voltage

Constant impedance loads, for example an incandescent light or the heating element in an electric water heater, are a constant impedance, whose resulting load varies as the square of the voltage.

Constant current loads, including some types of power supplies, many electroplating systems, and other industrial processes, are basically constant current loads. Energy drawn from the system is proportional to voltage.

Constant power loads, such as some types of electronic power supplies, and to an approximate degree, induction motors, vary their load only slightly in response to changes in voltage.

In each category, reference to a load as “1 kW” refers to its value at 1.0 PU voltage. Table 2 shows the value of a 1 kW load in each category, as a function of voltage.

TABLE 2 – ACTUAL LOAD OF A “1 kW LOAD” OF VARIOUS CATEGORIES AS A FUNCTION OF THE PER UNIT SUPPLY VOLTAGE - WATTS

PU Line Voltage	Constant			Ratio	Error
	Power	Current	Imped.		
0.88	1000	880	774	886	0.73%
0.90	1000	900	810	904	0.48%
0.92	1000	920	846	923	0.29%
0.94	1000	940	884	941	0.15%
0.96	1000	960	922	961	0.05%
0.98	1000	980	960	980	0.01%
1.00	1000	1000	1000	1000	0.00%
1.02	1000	1020	1040	1020	0.03%
1.04	1000	1040	1082	1041	0.11%
1.06	1000	1060	1124	1062	0.21%
1.08	1000	1080	1166	1084	0.35%
1.10	1000	1100	1210	1106	0.52%
1.12	1000	1120	1254	1128	0.72%

Correct representation of voltage sensitivity can be an important factor in analysis of power system performance, particularly on systems that are near permissible limits. Usually, engineering studies of transmission system are carried out using representations of the load as constant power. This works well, because the customer loads are usually downstream of load-tap changing transformers and voltage regulators and so are insensitive (in the steady state case) to changes in the voltages being modeled.

On the distribution system, however, correct representation of voltage sensitivity is critical for accurate analysis of voltage drop and equipment loads. As can be determined from study of Table 2, the difference between constant power and constant impedance “1 kW” loads, at 8% voltage drop (typical of the maximum primary feeder voltage drop permitted on many systems), is 15%. Thus, the incorrect categorization of load voltage sensitivity could lead to a significant over or under estimation of voltage drop and loading on a feeder.

Tests to determine voltage sensitivity on a feeder circuit or low-side bus basis, by varying LTC or voltage regulator tap position at the substation, are recommended to determine exact behavior. In the absence of specific information, representation as a constant current (load is proportional to voltage) is recommended. Within the United States, the following rule-of-thumb works somewhat better

Summer peaking residential and commercial feeders as a split of 67% constant power and 33% constant impedance.

Winter peaking residential and commercial feeders as a split of 40% constant power and 60% constant impedance.

Industrial feeders as constant power feeders

In developing countries, rural loads are best represented as 25% constant power and 75% constant impedance and those in urban areas as an even split of constant power and impedance.

Load flow and similar iterative engineering computations are faster and more stable in convergence if loads are represented as constant power than as constant impedance or current (fewer factors change value from iteration to iteration). In some cases, when a load flow computation will not

converge, changing input data to represent all loads as constant power will promote convergence to an approximate solution.

Analytical studies and digital programs can be simplified by deleting the constant current category and using only constant power and constant impedance type loads. Constant current load behavior (the rarest of the three types) can be represented over the range .88 to 1.12 PU voltage, with less than .75% error, if modeled as a mixture of 49.64% constant power, and 50.35% constant impedance load. The column labeled “Ratio” in Table 2 shows this mix of load types, with the right-most column giving the percentage error in representation of an actual constant current load.

10. Characterizing Customers by Class

Usually, electric consumers are grouped into classes of broadly similar demand behavior. *A class is any subset of customers whose distinction as a separate group helps identify or track load behavior in a way that improves the effectiveness of the analysis being performed.* Electric utilities most often distinguish customers by rate class (pricing category). Customer studies (load research) often make additional distinctions based on demographics, income, or SIC (standard industrial classification) code.

Regardless, usually all customers in a class have similar daily load curve shapes and per-customer peak demands, because they employ similar types of appliances, have similar needs and schedules, and respond in a similar fashion to weather and changes in season. Table 3 and Fig. 4 illustrate how customer class values vary in one power system.

TABLE 3—PEAK HOURLY DEMAND VALUES FOR CUSTOMERS IN A UTILITY SYSTEM IN NEW ENGLAND, 1992

Class	Peak kW	kWh	Time of Peak
Farm - residential	6.2	26,200	9 PM Summer
Rural residential	4.4	15,600	8 AM Winter
Suburban residential	3.2	12,000	6 PM Summer
Urban residential	3.3	11,800	6 PM Summer
Small retail commercial	7.0	23,000	4 PM Summer
Small non-retail comm.	5.6	19,600	9 AM Winter
Medium retail commercial	33	110,000	4 PM Summer
Medium non-retail comm.	51	177,000	9 AM Winter
School	610	1,500,000	8 AM Winter
Large commercial	28	109,000	2 PM Summer
Small industrial	88	513,000	2 PM Summer
Medium general service	220	1,350,000	3 PM Summer

11. Customer Class Peaks Occur at Different Times

Often, the various classes do not demand their peak energy at the same time, as shown in Fig. 4. As a result, the system peak load may be substantially less than the sum of the individual customer class loads (Fig.5). This is called *inter-class diversity*, or *inter-class coincidence*, of load. A class’s or customer’s load at time of system peak is its contribution to system peak, and the ratio of its peak contribution to its own peak load is its *peak responsibility factor*. Table 4 shows the peak load and responsibility factors of various classes in a utility system in the central United States.

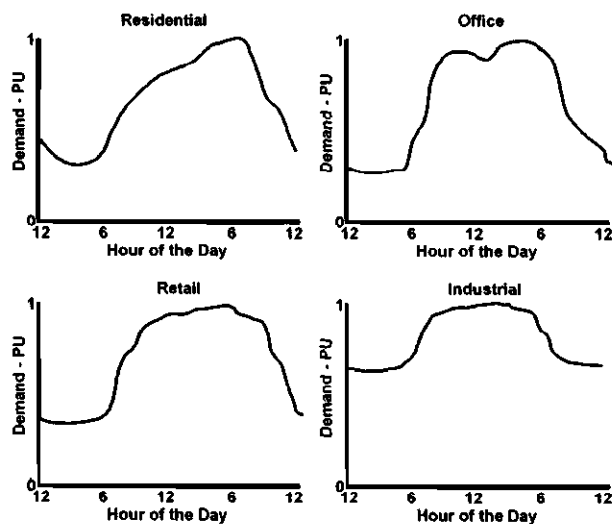

Fig. 4—Customer classes typically display different daily load curves. Shown here are the class summer peak-day loads from a metropolitan utility system in the southern United States.

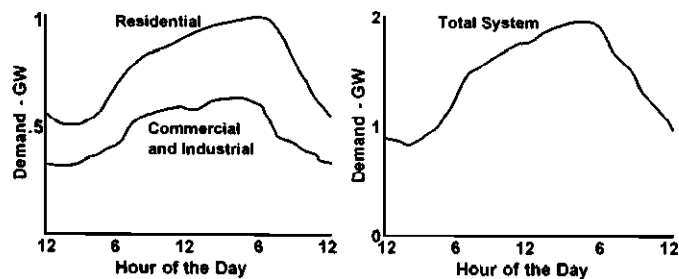

Fig. 5—Peak system load in this metropolitan system in Europe occurs when a combination of both residential and commercial-industrial load is at a maximum.

TABLE 4—SYSTEM PEAK RESPONSIBILITY BY CUSTOMER CLASS FOR A UTILITY SYSTEM IN THE CENTRAL UNITED STATES, 1992

Customer Class	Class Peak - GW	Peak Contr. - GW	Responsibility Factor
Agricultural	.81	.45	.56
Rural residential	.22	.22	1.00
Residential, houses	1.55	1.32	.85
Residential, apartments	.44	.39	.89
Small retail/office	.25	.21	.84
Retail commercial	.88	.79	.89
Offices comm.	.66	.57	.78
Small & medium indus.	.27	.25	.93
Large industrial	.83	.80	.96
Municipal	.23	.18	.85
Military/Fed. Govern.	.06	.06	1.00
Schools	.16	.16	1.00
Other	.10	.6	.6
Total	6.07	5.66	.93

III. CONVERSION OF ELECTRICITY TO END USE

12. Appliances Convert Electricity to End Uses

Each end-use, such as lighting, is satisfied through the application of appliances or devices that convert electricity into the desired end product. For lighting, a wide range of illumination devices can be used, from incandescent bulbs to fluorescent tubes, to sodium vapor and high-pressure monochromatic gas-discharge tubes and lasers. Each uses electric power to produce visible light. Each has advantages with respect to the other illuminating devices that gives it an appeal in some situations. But regardless of type or advantages, all of these devices require electric power to function, and create an electric load when activated.

The term load, in this context, refers to the electric power requirement of a device that is connected to and draws energy from the T&D system to accomplish some purpose (opening a garage door) or to convert that power to some other form of energy (light, heat). Loads are usually rated by the level of power they require, measured in units of volt-amperes, or watts. Large loads are measured in kilowatts (thousands of watts) or megawatts (millions of watts). Power ratings of loads and T&D equipment refer to the device at a specific *nominal voltage*. For example, an incandescent light bulb might be rated 100 watts at 115 volts. If provided more or less voltage, its load would be different from 100 watts. Loads can be single-phase or multi-phase, and they can have real (resistive only) or complex impedance (reactance), too.

The electric load in any one end-use category depends not only on the number of customers and their aggregate demand for the end-use, but also on the types of devices they are using to convert electricity to that end-use. For example, lighting load will be higher if most customers are using incandescent lighting to meet their needs, than if they are using only fluorescent lighting. Similarly, if a large percentage of customers use only resistive space heating instead of more efficient heat pumps, electric demand will be greater, even if the end-use demand is the same. Power quality needs also are function of appliance type. For example, variable-speed chillers are more sensitive to voltage sags than traditional constant-speed building cooling systems.

Therefore, detailed analysis of electric load in a utility system generally proceeds into subcategories within each customer class's end-use categories, with the subcategories characterized by *appliance type*, as shown in Fig. 6. The boxes indicate load curve models, the ellipses are multipliers corresponding to the number of customers or the percentage of customers in a class that have a certain appliance (e.g., thermal storage heating). Only part of the model is shown. Dotted lines indicate links to portions not illustrated.

In detailed load studies, behavior of load in each category is analyzed by use of temporal curves, plotting demand for the end-use (e.g., gallons of hot water, BTU of heating required) or the electrical load, or cost of service interruption, as a function of time. Information on the percentage of customers employing each type of appliance, their end-use demand schedules, and the electrical and efficiency characteristics of the appliances, comprises the end use model.

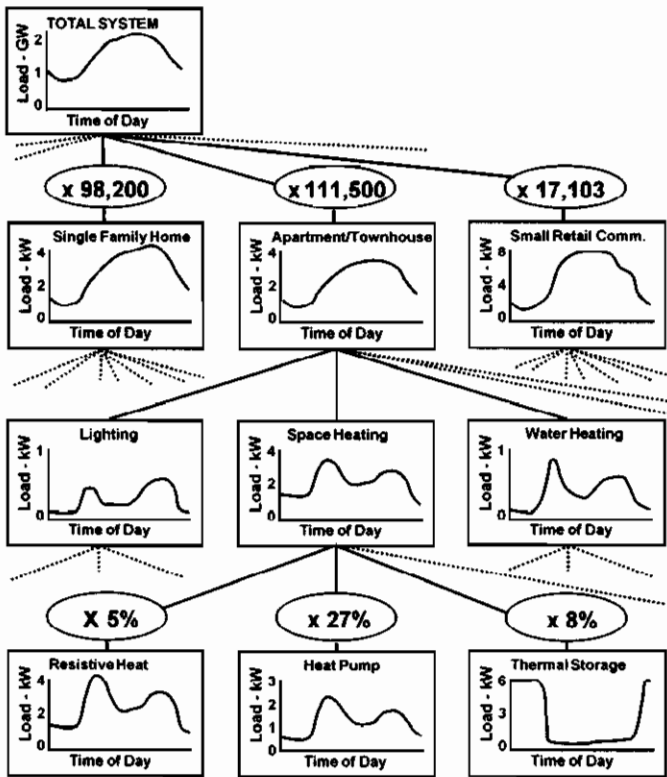

Fig. 6—Structure of an “end-use analysis” based on customer, end-use, and appliance subcategory load curves.

13. Appliance Output Is Controlled by Varying Duty Cycle

Only a minority of electrical devices vary their load as a function of the end-use demand placed upon them. For example, the motor drive in a variable speed heat pump will control its RPM (and hence electric load) to correspond to the pumping requirements of the system, on a moment to moment basis. However, such appliances are a rarity. The majority of loads connected to a power system vary their output as a function of time by changing their duty cycle. *Duty cycle* is the portion of time the device spends operating during any period.

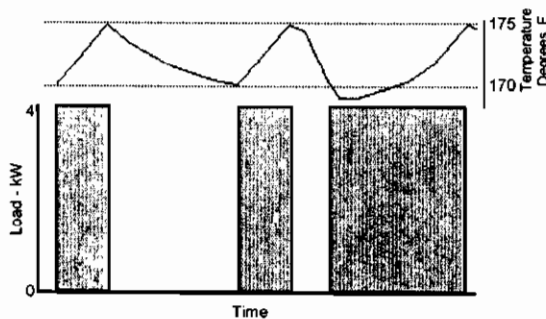

Fig 7—Electric load (bottom) and internal water temperature (top) of a 4,000 watt, 50-gallon storage electric water heater as a function of time.

For example, most storage water heaters function in a simple manner to keep the water they provide at a constant temperature, regardless of demand, as illustrated in Fig. 7. A thermostat is set at the desired temperature, for example 172.5°F. The thermostat has a “deadband,” a narrow range of temperatures on each side of the setting, within which the thermostat does nothing. A typical deadband might be 5°F – for example from 170°F to 175°F when the thermostat is set to 172.5°F. Whenever the temperature drops below the deadband’s lower limit, the thermostat activates a relay (or electric circuit) that turns on the heating element. The element is left in operation until it raises the water temperature above the upper limit of the thermostat’s deadband (175°F), at which point the thermostat activates the relay to shut off the heater. The water temperature rises and falls slightly as the unit cycles on and off, as shown, but the electric load cycles completely from “all on” to “all off,” as the device tries to maintain a constant temperature.

The 4,000-watt water heater, as illustrated in Fig. 7, creates a load of 4,000 watts whenever it is energized by its thermostat. Otherwise it creates no load at all. Over a period of 24 hours, it will vary its duty cycle in response to demand for hot water. When water heating demand is lightest, the water heater may operate only a few minutes in each hour. But when demand is highest, for example in the evening when dishwashing, clothes washing, bathing, and other activities are at a peak, it may operate continuously for an hour or more, as shown in Fig. 8.



Fig. 8—The water heater’s load profile over a typical day.

A large portion of the electric appliances in most electric systems, often a majority of the electric demand, operates in this manner. The consumer does not directly control the appliance’s on-off operation. Instead, the consumers sets a desired end-use measure (temperature, air pressure) on a controlling device (a thermostat, a pressure switch), and this device varies the appliance’s duty cycle in response to end-use demand. In the residential class, air conditioners, space heaters, refrigerators, freezers, water heaters, irons, and ovens fall into this category. In the industrial class, process heaters, air and water pressurization systems, and many fluid handling systems use this method of control. Fig. 8 shows the resulting daily load curve for a water heater. It cycles on and off, operating for longer times during periods of high demand, and only briefly when there is no demand and it must only make up for thermal losses. In all cases, however, when the water heater is operating its load is the same – 4 kW.

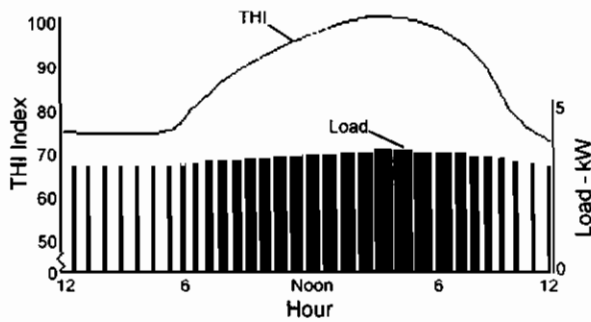

Fig. 9—Daily cycle of THI (temperature-humidity-illumination index) and air conditioner operation. The air conditioner's connected load varies slightly as a function of THI.

Fig. 9 shows a slightly more complicated appliance behavior, in which duty cycle and device characteristics both vary. Here, an air conditioner cycles between on and off under thermostatic control. As temperature rises throughout the day, demand for cooling increases, and the air conditioner spends a greater portion of its time in the "on" state, until in late afternoon it is operating all but a few minutes in every hour. The diagram illustrates a common secondary effect due to AC unit compressor design. When ambient temperature (temperature of the air around the AC radiator) rises, back pressure in the compressor increases, forcing the unit's inductive motor to work harder and creating a slightly higher electrical load. Thus, its connected load varies with temperature, as shown.

14. Appliance Duty Cycles and Coincidence of Load

Fig. 10 shows the type of load curve widely used throughout the power industry as representative of a residential water heater's daily load curve. This particular load curve was taken from a comprehensive water heater load survey done in the 1980s by a utility in the northern United States, prior to design and implementation of a water-heater load control program. This curve shown has a maximum value of 1,100 watts during a brief early morning household activity peak, and a lower, but broader early evening peak.

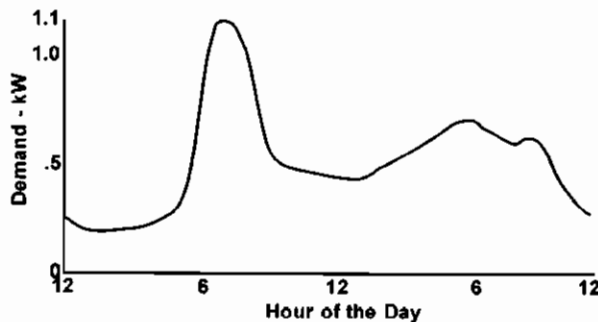

Fig. 10—A average residential water heater's coincident demand curve — 1/100,000 of the load resulting from 100,000 water heaters. Any single water heater has a load curve similar to that shown in Fig. 8, but its contribution to system load is depicted as shown here. This curve is also the expectation of any one water heater's load by time of day.

The daily water heater load curve in Fig. 10 looks nothing like the daily water heater load curve in Fig. 8. In Fig. 10, load varies smoothly from moment to moment, between a minimum of .53 kW and a maximum of 1.1 kW, displaying none of the blocky, on-off cycling shown in Fig. 8. Neither Fig. 10 nor Fig. 8 is incorrect. Each is accurate, but only within its own context. Their difference is attributable to *intra-class coincidence* of load.

Fig. 11 illustrates the relationship between the two water heater load curves. On the top row, load curves A, and B show the load curves for two electric water heaters in neighboring homes on the same day. Curve C shows the curve for the water heater in B, on another day. All three represent the same appliance under nearly identical conditions. Timing of the load blocks varies, but in all cases the load is "all or nothing."

Load curve D shows the combined loads of both neighboring water heaters (the sum of curves A and B) on February 6, 1994. Even during the peak hour, the average water heater operates only a fraction of the time (in the system whose average water heater is shown in Fig. 10, exactly 1,100/4,000 of the time, assuming all water heaters are 4,000 watts connected load). For this reason, instances when the two water heaters operate simultaneously are rare, but this does happen several times each day, for brief periods.

Curve E shows the curve for five water heaters (the units in five neighboring homes, including A and B). With five units, the likelihood of two or more units operating at any one time is increased considerably. However, the likelihood of all five are operating at the same time is quite remote (roughly 1/100,000 raised to the fifth power, or less than .1 percent). Curve F shows the combined load curve of 50 water heaters (all those served by one primary-voltage lateral).

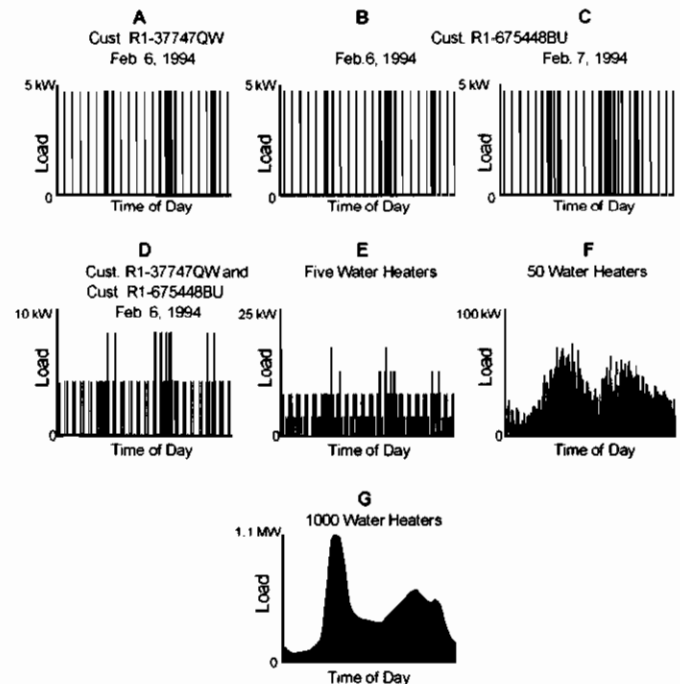

Fig. 11—Daily load curves for different sized groups of residential water heaters.

As an increasingly large number of water heaters is considered *as a group*, the erratic, back-and-forth behavior of the individual water heater load curve gradually disappears. The load curve representing a group's load becomes smoother as the size of the group is increased, the peak load per water heater drops, and the duration at lengthens. By the time 1,000 water heaters are reached (Fig. 11G) the curve shape is quite smooth, and peak load is at its coincident value of 1,100 watts/unit.

Thus, Fig. 10 (same as Fig. 11G), while unlike any individual water heater's actual load curve, is an accurate representation of water heater behavior from either of two perspectives. First, it is a diagram of average contribution to system load, or coincident load, on a per water heater basis – 1/100,000 of the load of the 100,000 water heaters in the system. Second, it is the *expectation* of a water heater's load as a function of time. To a certain extent, the exact timing of the "on" load blocks in Fig. 7- 9, and Fig. 11 is random from day to day. Fig. 10 is a representation of the expected load of one water heater, as a function of time; the best estimate, a day ahead, of load as a function of time.

Note that energy per water heater (area under the load curve) is not a function of group size. The energy used per water heater is constant in any of the load curves in Fig. 11.

15. Coincident Load Behavior in General

Most of the major loads in any home or business behave in a manner similar to the on-off, coincident behavior shown in Fig. 7 - 9 and Fig. 11. Refrigerators and freezers, air conditioners, space heaters, water heaters, and electric ovens in homes; and pressurizers, water heaters, process and other finish heaters, and other equipment in industry; all turn on and off in a performance-regulated duty cycle manner. As a result, individual household load curves, and many commercial and industrial site load curves, display the blocky, on-off load behavior shown in Fig. 12A. As with the water heaters, when a group of similar loads (homes in this case) is considered as a single load, the load curve becomes smoother, the peak load drops, and the minimum load rises. Note that the vertical scale of all six load profiles shown in Fig. 12 is in "load per customer" for each group.

The 22 kW non-coincident needle peak demand shown in Fig. 12A for a single household is high, but not extraordinary for homes in the southern United States. Load curve A represents a 2100 square foot residence with 36 kW connected load (sum of all possible heat pump, water heater, garage door opener, washer-dryer, other appliance and lighting loads). While customer characteristics vary from one system to another, the qualitative curve shape behavior shown in Fig. 12, as well as the tendency of load curves to become smoother, and peak loads lower, as group size is increased, *apply to all power systems*.

16. Coincident Curve: Expectation of Non-Coincident Load

The interpretation of coincident load behavior as the expectation of non-coincident load behavior, as explained in sub-section 14 (water heater example) is generally applicable.

While no single customer within the group depicted in Fig. 12 would have an individual load curve that looked anything like Fig. 12B (every customer's load curve looks something like Fig. 12A), the smooth coincident load curve for the group has *two* legitimate interpretations.

1. *The curve is an individual customer's contribution to system load.* On the average, each customer of this class adds this load to the system. Add ten thousand new customers of this type, and the *system load curve* will increase by ten thousand times this curve.
2. *The curve is the expectation of an individual customer's load.* Every customer has a load that looks something like the on-off behavior shown in Fig. 12A, but each has slightly different on-off times that vary in an unpredictable manner from day to day. Fig. 12B gives the expectation, the probability-weighted value of daily load that one could expect from a customer of this class, selected at random. The fact that the expectation is smooth, while actual behavior is erratic, is a result of the unpredictability of timing in when appliances switch on and off.

Commercial and industrial customers exhibit intra-class coincident behavior qualitatively similar to that discussed here, but the shape of their coincidence curves may be (usually is) different than for residential. By contrast, inter-class coincidence is the difference in timing of peak periods among classes (Fig. 4).

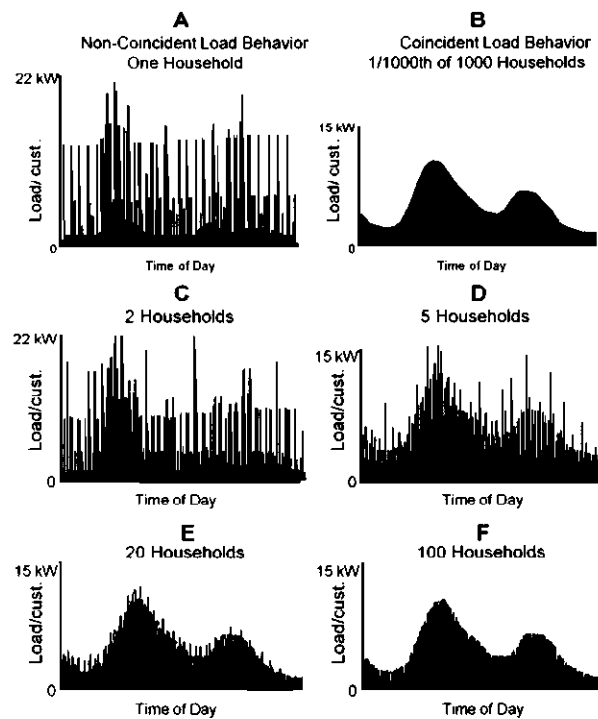

Fig. 12–Non-coincident (A) and coincident (B) winter peak day load curves for home in a suburban area of Florida. Curves B through F show the gradual transformation from non-coincident to coincident behavior as group size increases. Feeders see load curves similar to B. Every service drop sees a load curve like A.

17. Importance of Coincidence Assessment in T&D Design

Coincidence behavior of load, as depicted in Fig. 12, is important to T&D planning and engineering. Equipment such as service drops, service lines (LV), and service transformers, which serve small numbers of customers, must be designed to handle load behavior, including customer needle peaks, of the type depicted in Fig. 12A. Normal service does not require this equipment to handle these load levels for more than a few minutes at a time, a factor that can be considered in determining the load rating of this equipment. By contrast, equipment serving large groups of customers sees fully coincident load curve behavior (Fig. 12B). Peak load per customer is lower, but peak duration is much longer.

Usually, in spite of the high needle peak values, the thermal capacity of service drops, service (LV) circuits, and service transformers can be determined based on coincident peak load values. The thermal time constants for most conductor, cable, and transformers are much longer than the duration of any needle peak. As a result, thermal loading calculated on the basis of coincident curve shape is usually representative of the thermal loads that will result from the actual non-coincident load curves.

Voltage drop and losses are another matter, however. Fig. 13 compares the losses that result in a set of triplex service drops, for the two load curves Fig. 12A and Fig. 12B. The result shown is typical. Use of coincident rather than non-coincident load curve typically results in errors of up to 50% in estimating low voltage system losses, and up to 16% in estimating the total voltage drop to the customer's meter.

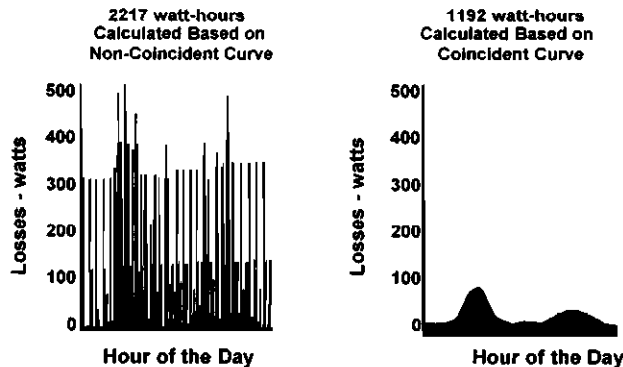

Fig. 13—Electric losses through a typical set of residential service drops, for the load curves in Fig. 12A (left) and 12B (right). Voltage drop would similarly show a significant difference.

Usually, coincident load curve data is readily available, but accurate non-coincident load curve data is not. In addition, many types of recording systems and analysis methods distort non-coincident load curve data when it is recorded, producing a smoother curve and lower peak loads than actually existed in the load. Gathering and verifying accurate load curve shape, load factor, and losses factor data for non-coincident and “partially coincident” (groups of 5-20 customers) equipment analysis requires care and attention to detail. However, it is recommended, due to the potential error that inexact data creates in losses and voltage drop and flicker computations.

18. Coincidence Factors and Curves

Usually, coincident load behavior is summarized for application to power distribution system engineering by the *coincidence factor*, and the coincidence curve. Coincidence factor is a measure of how peak load varies as a function of group size for customers

$$C = \frac{\text{observed peak for the group}}{\sum(\text{individual peaks})} \quad (3)$$

Fig. 12 illustrates well that as the number of customers in the group increases, the peak load/customer usually drops by a considerable amount. Coincidence factor, C , can be represented of as a function of the number of customers, n , in a group

$$C(n) = \frac{\text{peak load of a group of } n \text{ customers}}{n \times (\text{average individual peak load})} \quad (4)$$

where n is the number of customers in the group, and $1 < n < N =$ number of customers in the utility system

Diversity factor, $D(n)$, is the inverse of coincidence factor. It measures how much higher the customer's individual peak is than its contribution to group peak.

$$D = \text{Diversity factor} = 1/\text{Coincidence factor} \quad (5)$$

The coincidence factor, $C(n)$, has a value between 0 and 1, and varies with the number of customers in a fashion identical to the way the peak load varies. Fig. 14 shows a *coincidence curve*, a plot of how $C(n)$ varies with n . Typically, for residential and small commercial load classes, $C(n)$ tends toward an asymptotic value of between .33 and .50 for large values of n . The value for larger commercial and industrial customers is usually higher, — .75 to .85 is typical. Table 5 gives representative asymptotic coincidence values for typical customer classes. Coincidence behavior varies greatly from one utility to another, and among customer classes. The curves and tables shown here are representative of the *type* of behavior seen in all power systems, but can not be quantitatively generalized to all power systems.

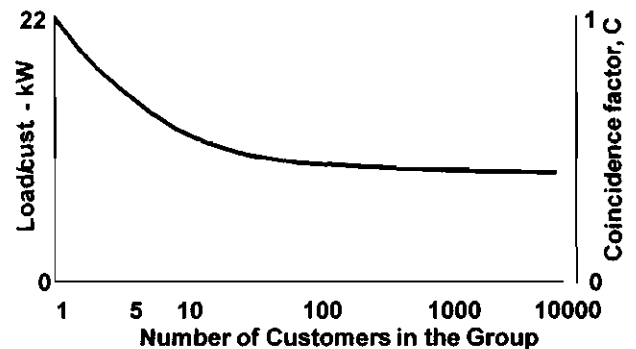

Fig. 14—Peak load per customer as a function of the number of customers in a group (left scale) and coincidence factor (right scale) for residential class, from a power system in the central US.

TABLE 5—ASYMPTOTIC WINTER PEAK SEASON COINCIDENCE FACTOR BY CUSTOMER CLASS, FROM A SYSTEM IN THE CENTRAL UNITED STATES, BASED ON 15 MINUTE DEMAND PERIOD DATA

Customer Class	C(n) for n large	
	Summer	Winter
Agricultural	.56	.38
Residential	.39	.46
Small retail Commercial	.47	.48
Large Commercial	.90	.91
Small Industrial	.52	.50
Large Industrial	.97	.98
Other	.87	.82

19. Coincidence of Load Varies as Demand Varies

The coincidence curves and coincident data normally gathered and applied to power system engineering represent peak period behavior – the load conditions for which the system design is targeted. On occasion, however, off-peak coincidence data are gathered, usually to support detailed study of load control, energy efficiency, and other integrated resource programs (discussed later in this section), or for detailed assessment of losses behavior and equipment performance on an annual basis.

The “connected” load on a power system does not vary substantially as a function of time. Electric demand varies because the portion of devices activated by their control system (whether manual or automatic) varies as a function of time. During peak periods, a greater fraction of all customer appliances are activated: There is a higher coincidence of loads. For example, in some areas in the southern United States, over 90% of all residential space heaters are operating at the time (15-minute demand period) of winter system peak. However, during the maximum demand period of an off-peak day (e.g., a day in late fall) only 20% will be operating.

Regardless, on either a winter peak day, or an off peak fall day, individual households create needle peak loads as major appliances operate through their on-off cycles. However, during off-peak times, there will fewer needle peaks, of less average duration. As a result, the likelihood of overlap of needle peaks (e.g., coincidence) among neighboring customers is less than at peak. As a result, coincidence curves representing load behavior during peak and an off-peak times will differ, as shown in Fig. 15.

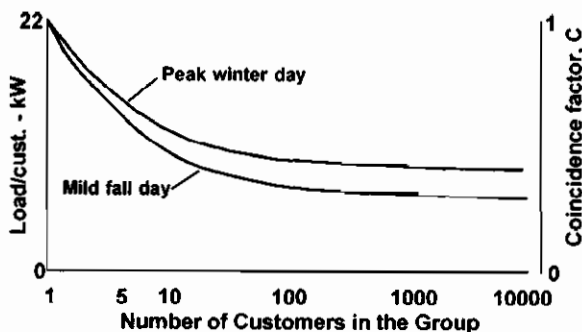

Fig. 15—Coincidence curve for winter peak conditions, and for off-peak conditions (late fall).

20. Load Duration Curves

A convenient way to study load behavior for some engineering purposes is to order the demand samples from greatest to smallest, rather than as a function of time, as shown in Fig. 16. The two diagrams shown in Fig. 16 consist of the same 24 numbers, in a different order. Peak load, minimum load, and energy (area under the curve) are the same for both.

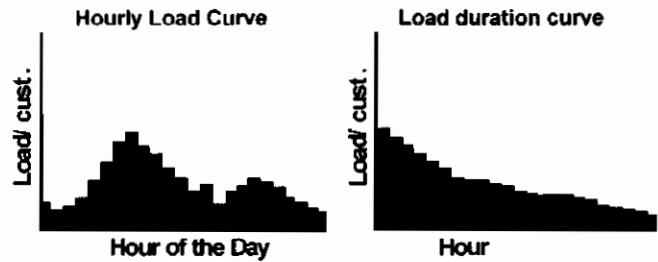

Fig.16—The hourly demand samples in a 24-hour load curve are “re-ordered” from greatest magnitude to least to form a daily load duration curve.

Load duration curve behavior will vary as a function of the level of the system. Load duration curves for small groups of customers will have a greater ratio of peak to minimum than similar curves for larger groups. Those for very small groups (e.g. one or two customers) will have a pronounced “blockiness,” consisting of plateaus – many hours of similar demand level (at least if the load data were sampled at a fast enough rate). The plateaus correspond to combinations of major appliance loads. The ultimate “plateau,” would be a load duration curve of a single appliance, for example a water heater that operated a total of 1,180 hours during the year. This appliance’s load duration curve would show 1,180 hours at its full load, and 7,580 hours at no load, with no values in between.

Annual load duration curves. Most often, load duration curves are produced on an annual basis, reordering all 8,760 hourly loads (or all 35,040 quarter hour samples if using 15-minute demand intervals) in the year from highest to lowest to form a diagram like that shown in Fig. 17. The load shown was above 997 MW (system minimum) 8,760 hours in the year, but above 2,000 MW for only 1700 hours.

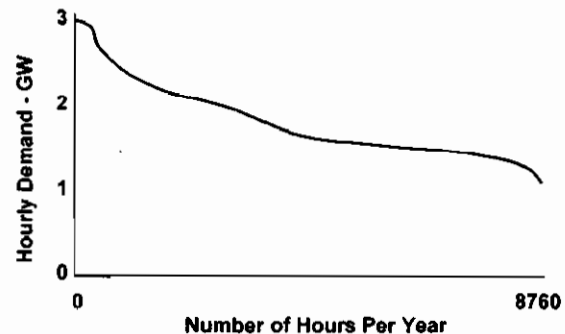

Fig. 17—Annual load duration curve for a power system serving a metropolitan area in the southeastern United States.

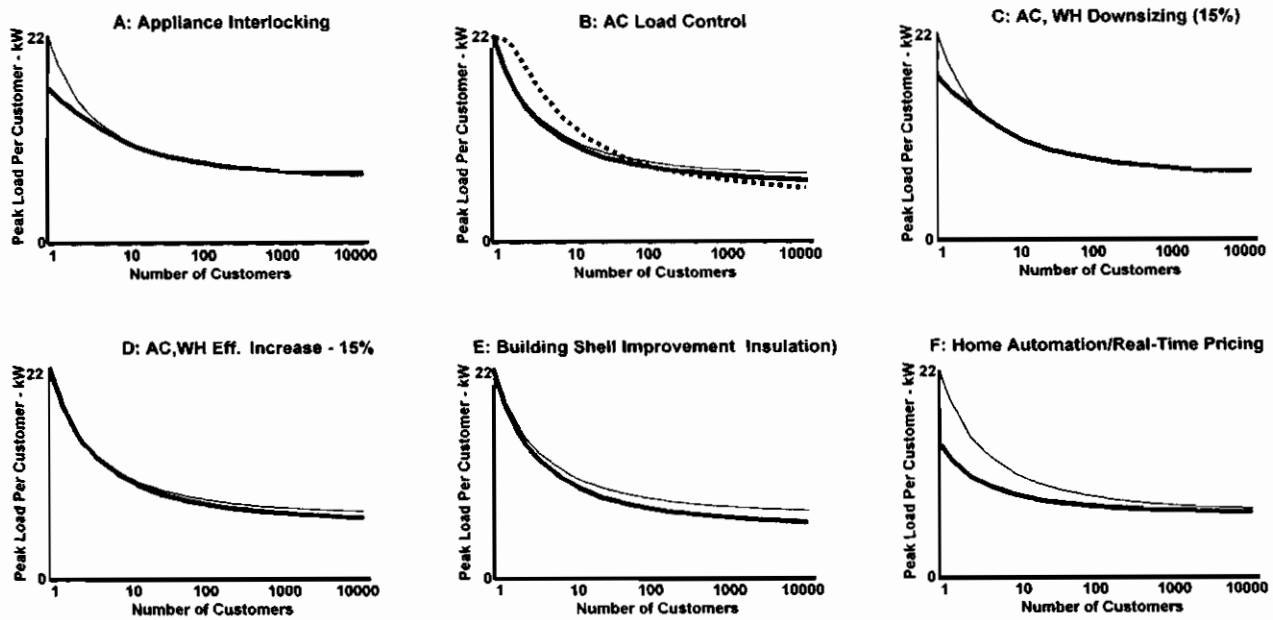

Fig. 18—Examples of coincidence curve modification due to various types of demand-side management (DSM) programs. Thin solid line indicates base coincidence behavior. Heavier lines indicate the coincidence behavior of the load after DSM modification.

21. Coincidence Curve and DSM Interaction

Many integrated resource methods, such as appliance interlocking and load control, and other demand-side management (DSM) measures, change the coincidence behavior of customer loads, not the loads themselves. For example, adding insulation and weather-sealing to a building does nothing to change the load of its air conditioning and heating system. These energy conservation measures slow heat transfer into and out of the building, lengthening the “off” portions of every on-off cycle. The same needle peaks occur, but spaced farther apart in time. Basically, this DSM measure cuts the percent of time the AC/heater is on, and hence the coincidence of these appliances.

Fig. 18A illustrates the change in coincident load behavior made by universal use of appliance interlocking among all residential customers in a large group. Interlocking involves jointly wiring the thermostats for the electric water heater, and the air-conditioner/heater, so that the water heater cannot operate if the air-conditioner/heater is operating. It is a simple form of the appliance schedule optimization that can be affected with home automation systems.

The broad line in Fig. 18A shows the resulting coincidence curve. The 22 kW peak values, which occasionally resulted from the random overlapping of appliances activating simultaneously, are now completely avoided. As a result, the 22 kW peak values, and the value of the coincidence curve at the Y-axis, are both reduced by the magnitude of the water heater’s connected load (4 kW in this example).

However, the water heater is not denied energy. Its use is merely deferred until periods when the air conditioner or heater is switched off. As soon as the master (AC-heater) appliance

switches off, the water heater will activate. Over any lengthy period of time (an hour or more) both appliances usually receive all the energy they need. Thus, over any large group of customers, coincidence of energy usage within any demand period will not be affected. The asymptote is unchanged.

An opposite type of effect is shown by the broad line in Fig. 18B. Appliance load control is basically a method to limit duty cycle, and thus coincidence of load. Typically, load controllers are set to limit the operation of any appliance to no more than a certain number of minutes per demand period. For example, a controller might be set to limit its air conditioner to no more than 12 minutes operation out of any 15 minute period, a duty cycle of 80%. During peak conditions, the average thermostat may want to operate its air conditioner 90% of the time. Thus, this load control effects an 11% reduction in air conditioner energy usage. As a result, the asymptotic value of the coincidence curve, for large groups of customers with load control, is reduced.

Such a load control measure makes no impact on the maximum height of the needle peaks produced by any household. The AC unit is still the same connected load, and still likely to overlap with other appliances to create high needle peaks. As a result, load control has no impact on the value of the coincidence curve for individual customers. In cases where control is poorly coordinated, or the load control is aggressively used to maximize the reduction of coincident peak load, it can produce a “rebound effect,” increasing peak loads on some levels of the system, as shown by the dotted line in Fig. 18B. Fig. 18C through Fig. 18F represent the actions of other often-used DSM approaches.

Fig. 18 illustrates two very important points about DSM programs. First, DSM programs do not necessarily produce

similar amounts of load reduction on all levels of the power system. Second, by use of coincidence curve analysis of the type shown in Fig. 18, it is possible to target a DSM program's load reductions at particular levels of the power system. DSM measures that affect the peak loads of large groups of customers, or small groups, can be selected as needed to target feeder or service (LV) levels.

IV. MEASURING LOAD CURVE DATA

Regardless of the actual behavior of the electric load, it is measured and sampled through the "eyes" of equipment and procedures which may introduce errors by not capturing completely all of the load's characteristics. Many types of load recording perform a type of filtering that makes load behavior look more coincident (smoother, lower peak) than it actually was. Other types mis-recording of load cycles in a way that renders the load curve data virtually useless. In both cases, the data looks like load curves, but is inaccurate. Regardless, power engineers must be aware of the source of all load data, the method used in its recording, and any limitations it creates on the accuracy or use of the resulting data.

22. Load Sampling Rate and Type

Most load measurement, recording, and analysis equipment and procedures work with load curve data as *sampled data*. Load values are measured and recorded at uniform intervals of time. For example, often load curves are represented in engineering studies as 24 hourly loads. Many load recorders measure and store load behavior on a 15-minute basis. There are two very important aspects of sampling. The first is the *type* of sampling used, the second is the *rate* of its application.

Discrete sampling measures and records the load's value at specific periodic instances. For example, load recorder may measure electrical load every 15 minutes. Every quarter hour, this device "opens its eyes" to sample the load, and records the value, and begins a waiting period until the next sampling instant. What the load does in between those 15-minute sample periods is immaterial to the recorder.

This kind of sampling, which is often called *instantaneous sampling*, is the type normally dealt with in textbooks on signal processing as "discrete sampling." Much of the load data used in power systems studies comes from this type of sampling. Many types of distribution load recorders ("load loggers") do only instantaneous sampling. SCADA systems that "trap" load readings on a periodic basis do instantaneous sampling. Manual reading of load strip charts is basically discrete sampling: typically, load data is prepared for computer processing from strip charts by an engineer or analyst who reads the value every so often from the strip chart and codes it into the computer data base.

Demand sampling, also called *period integration*, measures and records the total energy used during each period. If applied on a 15-minute basis, period integration records the energy (demand) during each 15-minute period. At the beginning of each measurement interval, a watt-hour meter is re-set to zero and begins counting the energy used. At the end of the period, the reading is recorded, and the counter is re-set

to zero. Demand recorders as used in revenue metering and most (but not all) electronic meters use this type of load recording.

Essentially, instantaneous sampling records the actual load value at specific instants spaced an interval apart. Period integration averages its load measurement over the entire sample interval between two of those instances. There can be, and usually is, a considerable difference in the recorded data, depending on which of these two different sampling techniques is used.

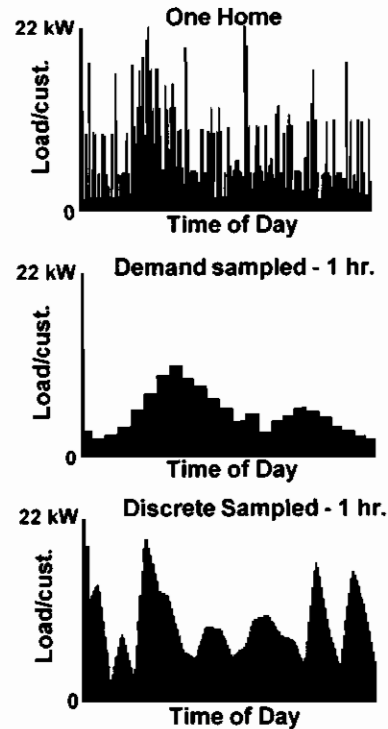

Fig. 19—Two different load sampling methods (middle, bottom) applied on an hourly basis to the residential load curve from Fig. 12A (top), produce quite different data.

Fig. 19 shows the single all-electric household daily load curve from Fig. 12A, along with versions of it obtained by sampling on an hourly basis with period integration (middle) and discrete sampling (bottom).¹ Neither demand sampling nor instantaneous discrete sampling on an hourly basis captures all the details of the load behavior. However, in this case, discrete sampling produces a very spurious-looking load curve, for reasons that will be discussed later.

23. Observed Load Behavior and Sampling Rate

The second important aspect of load curve sampling is the *sampling rate*. Fig. 20 shows Fig. 12A load curve sampled with period integration on a 5, 15, 60 and 120-minute basis. Note that the resulting data displays *significantly* different

¹ The load curve in Fig. 12A was obtained using period integration (demand sampling) on a five-minute interval basis.

behavior, depending on sampling rate. As the sampling is done faster, the curve shape displays more of its blocky, on-off nature: the recorded data comes closer to representing the true load curve shape peak value.

But as shown, if a load is sampled by period integration applied at a slow rate, the resulting load data may look smooth, when, in fact, actual behavior is erratic, with high needle peaks. Fig. 21 shows peak demand for the data in Fig. 12, plotted as a function of period integration sampling rate. The *measured* peak load decreases as the sampling period increases from five-minutes to one hour. The reason is that the *sampling rate, or demand interval, defines the meaning of "peak"*. Sampled at one-minute intervals, the peak is the maximum 60-second demand. Sampling on an hourly basis smooths out a lot of the needle peaks, and yields a curve whose peak is the maximum one hour demand. A *non-coincident curve (top of Fig. 20) can look like it was smoother and very "coincident" simply because it was demand-sampled at too low a sampling rate.*

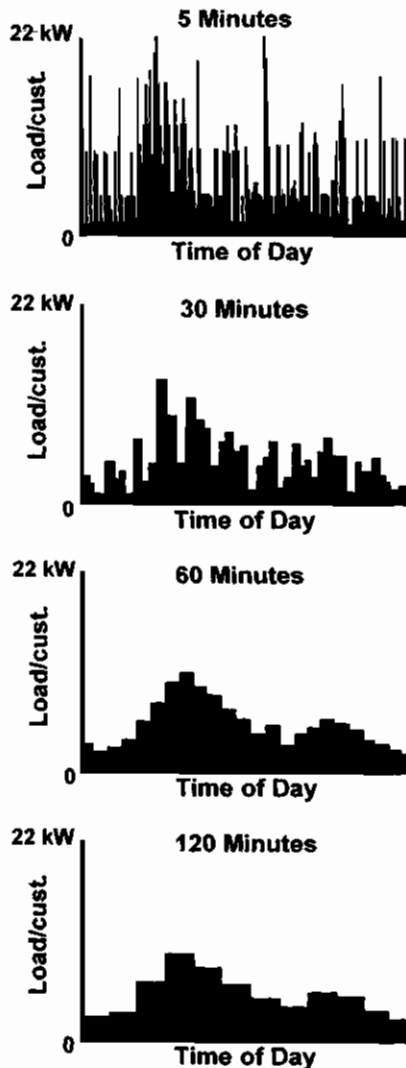

Fig. 20—Single household load (Fig. 12A) sampled by period integration (demand recorder) on a 5, 30, 60, 120-minute basis.

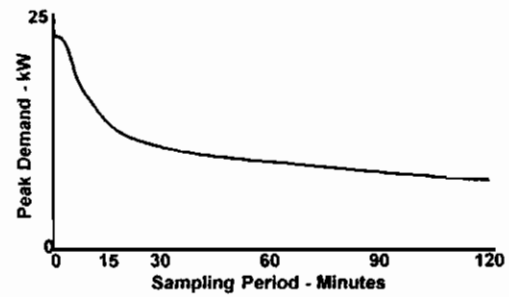

Fig. 21—Measured peak demand of a single residential customer varies greatly depending on the intervals used to sample its load.

As shown in Fig. 20 and Fig. 21, changing the sampling rate changes the perceived or measured peak value and the "choppiness" (variance) seen in the load curve. However, not all types of load curves are equally sensitive to this phenomenon. This effect is most pronounced when sampling non-coincident load curves – those representing small sets of appliances or just a few customer. It is minor or undetectable when sampling load of large groups of customers, such as an entire system.

Thus, the *apparent* coincidence of load changes as a function of sampling rate. Fig. 22 shows coincidence curves for the residential customers used earlier in Fig. 12-16, recomputed based on period integration sampling intervals of 5, 15, and 60 minutes. Because the peak load of a single customer, upon which coincidence factor computation is based, changes a great deal as a function of sampling rate (Fig. 21), the coincidence curve, itself, will change. Characteristics and sensitivity discussed here involve only period integration sampling (i.e., demand recorders), which is the most common approach to gathering load research and load curve data.

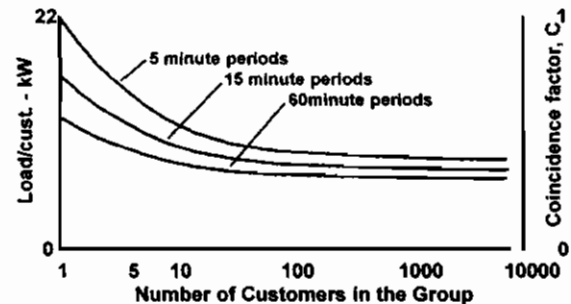

Fig. 22—Coincidence curves based on data measured at 60, 15, and 5 minute demand intervals for residential all-electric homes.

Aliasing. Instantaneous sampling has a far different interaction with sampling rate and recording accuracy than the period integration method discussed above. Fig. 23 shows the load for a single household (Fig. 12A) measured by instantaneous sampling on an hourly basis. One profile is the result of sampling instantaneously every hour, on the hour. The other is sampled hourly a quarter past the hour. The apparent load curve shape, and peak load of these two curves are different. Neither is an accurate representation of the actual load curve behavior.

The problem with instantaneous sampling applied in this case is that its rate is much too slow to “see” the load behavior. But unlike period integration, which smooths the load curve when applied at a slow rate, instantaneous discrete sampling distorts it, badly, as shown. The load being recorded in this case (Fig. 12A), has very erratic on-off load behavior common to non-coincident loads. It is simply random chance whether a particularly hourly recording instant, falls upon a needle peak, or a “needle valley.” For a load that has needle peaks, as does *any* individual household load, instantaneous sampling at a low sampling rate gives very poor, even completely unusable results.

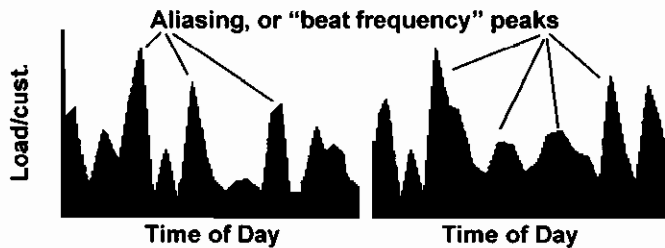

Fig. 23—Single household load curve (top of Fig. 20) sampled with hourly discrete sampling. Left: load curve sampled discretely every hour at the beginning of the hour. Right: sampled every hour 15 minutes after the hour.

While the two load curves in Fig. 23 look quite different, and bear no resemblance to the actual load curve shape, they share one characteristic: Both seem to oscillate back and forth every three to five hours. This is called aliasing, or “frequency folding” in signal theory, and is essentially a “beat frequency” generated by interference between the sampling rate, and the duty cycle rate of the appliances in Fig. 12A. Something similar to this occurs *any time* the measured quantity being sampled cycles back and forth at a faster rate than the sampling. In this example, appliances are cycling on and off at a rate much too fast for the hourly sampling rate to track. The beat frequency, or “aliasing profile” shown here, is a characteristic of under-sampled curves, something to watch for in load data. This type of distortion is common. It is fairly easy to detect by manual inspection (at least if given some training and understanding of what causes it), and its presence means that the load curve data is probably completely invalid.

In the presence of a great deal of erratic on-off load shifts, as occurs in most non-coincident loads, neither period integration (demand sampling) or instantaneous discrete sampling gives a completely accurate measurement of the load curve behavior. The integration method averages behavior over each period. The instantaneous method may chance upon any value. If the load being measured is fairly smooth, for example the load of an entire power system, then the level of error in either case is minute and the issue unimportance. On the other hand, if there is a good deal of non-coincident load behavior, as usually with loads measured on the distribution system, then the sampling rate phenomena discussed here are of concern in the load analysis and subsequent engineering.

24. Signal Engineering Perspective on Load Sampling

Load as a function of time is a signal, a value measured as a function of a continuously varying indexing parameter. A fundamental concept of signal engineering is that any signal can be represented as the sum of a set of sine waves of different frequencies and magnitudes. Low frequencies are slowly undulating sine waves, high frequencies represent rapid shifts in value. Any behavior that is characterized by rapid shifts in value is high frequency behavior. A load curve with a great deal of on-off “choppiness,” as for example Fig. 12A, has a large amount of relatively high frequency behavior. On the other hand, a smooth coincident load curve (Fig. 12B) has no high frequencies.

A fundamental theorem of sampled signal theory is that for instantaneously discrete sampled data to be valid, the sampling must be done at *twice the rate of the highest frequency in the signal*. Thus, to capture completely behavior of a load curve that has rapid shifts in load (and thus avoid errors as depicted in Fig. 23), it is necessary to sample it twice as often as its appliance loads cycle on and off. Since many appliances turn on and off within a fifteen or even ten-minute period, a minimum rate of five-minute sampling is necessary to see peak load, coincidence, and load curve behavior of such rapid cycling on an individual household basis. Better yet, one-minute samples can be used when trying to identify appliance or individual household load behavior in detail.

As mentioned in sub-section 23, instantaneous discrete sampling and period integration sampling differ dramatically in what they do if sampling rate falls short of these requirements. Essentially, period integration samples a load curve but *filters* it simultaneously. The averaging over each demand interval, as discussed above, smooths out choppiness (removes high frequencies). To a very good approximation, this type of sampling can be thought of as responding only to frequencies in the signal that are in the band of frequencies below one-half its sampling rate. The period integration responds to frequencies in the band it can “see” (those below its sampling rate limit) and ignores those above that limit.

Thus, sampling a load at half-hour intervals with period integration will obtain valid information on all frequencies in the load up to one cycle/hour, but will smooth out, or filter, fluctuations that are due to more rapid load behavior. (This perspective is slightly simplistic – i.e., only approximate on several minor technical points – but sufficient for this discussion). Instantaneous sampling, on the other hand, does not filtering, and tries to respond to everything it sees. However, it can only validly see frequencies below twice its sampling rate. It responds to frequencies above that limit by aliasing them, interpreting high frequency changes as low frequency. The result is a recorded load curve that may be invalid for most engineering and analysis purposes, as are those in Fig. 23.

25. Determination of the Sampling Method and Type

Both period integration and instantaneous sampling record only “approximate data” when applied at too low a sampling rate to track non-coincident behavior in the load. Instantaneous

sampling aliases high-frequency load behavior, producing load curve data that is useless for engineering and load analysis purposes. On the other hand, period integration filters out the high-frequency behavior in the load, producing curves that appear “more coincident” than the actual load. While this introduces an inaccuracy in subsequent load analysis and engineering, the curves are at least correct within the context of coincident load analysis.

In all cases, the preferred approach is to use period integration applied at a high enough rate to sample all the behavior pertinent to the engineering. However, choice of sampling rate and method is often a compromise between cost and accuracy. There will always be some load behavior occurring at a rate faster than can be sampled. Most loads contain motor starting transients and switching fluctuations that can only be captured by very high (10 Mhz) sampling rates.

The engineers and load analysts performing load research must either select a load recording method that suits their needs, or make only *valid* use of the data that has been given to them. Recommended practice is to research fully *where* the load curve data came from and *how* it was recorded, and if it has gone through any type of aggregation, filtering, or other process that might have altered coincident demand behavior. Although a majority of recorded load research data comes from demand interval recorders (period integration), a surprising number of sources produce discrete sampling. This includes data taken from SCADA systems, certain types of signal recorders, as well as most portable devices made for logging loads on feeder and service level circuits. In addition, many people forget that data “read by hand” from strip and circular charts is essentially discretely sampled data.

The fact that instantaneous sampling can, and often does, severely alias non-coincident load behavior does not mean it is necessarily a bad recording method, but it must be used with caution. Similarly, while period integration (demand recorders, etc.) always records accurately within its sampling rate limitations, it can be applied at too slow a rate to see needle peaks and non-coincident load behavior that are present.

High sample rate does not guarantee high frequencies. Sampling a signal at a fast rate does not guarantee that there will be high frequencies in the data. It could very well be that the load being sampled is smooth and has no high frequencies. Often, the sensors in recording machinery have a poor response to high-rate fluctuations. For example, strip chart recorders with a very tight dampers cannot respond to fast load shifts. Essentially, such mechanical stabilizers remove high frequencies from the load curve signal.

26. Addition and Averaging Filter Load Curve Data

Suppose every one of 1,000 households served by a particular feeder is sampled on a one-minute demand basis, for a full day (creating 1,440 samples per customer). An average load curve can then be formed by adding all 1000 load curves and dividing by 1000. The result will be a smooth, coincident curve, in fact the same curve shape (except for losses) that would have been recorded by measuring the feeder load at the substation. While adding together 1,000 load curves and

dividing by 1,000 may seem to be a proper way to produce a representative single-household non-coincident load curve, it gives a smooth coincident curve instead.

Addition is a signal filtering process. The “average” curve obtained by addition/division of a number of customer sample load curves is filtered, in a way that removed high frequency load fluctuations. This is the major reason why many T&D engineering studies and load analysis procedures consistently underestimate non-coincident load behavior and often underestimate the amount of coincidence (value of $C(n)$ for n very large). Most of the load curve data available to engineers has been obtained and processed by averaging a group of sampled customer load curves. This averaging produces only coincident load curve data. Most load curve data in use at electric utilities has been produced by averaging, over large enough customer samples, that it is effectively representation of completely coincident behavior.

It makes no difference, in the example cited above, whether the load curves added together were samples for 1,000 households on the same day, as described above, or perhaps 1000 days worth of one minute readings for one house. In either case, the result of adding together the sampled curves and averaging them to create an average with create a smooth, coincident load curve.

The usual reason that a set of load curves is averaged is to produce a single curve that is most representative of the set’s behavior. Simply put, algebraic methods (averaging) cannot be used to produce average non-coincident curves: there is no work-around within normal algebraic approaches. Instead, some form of pattern recognition or clustering analysis must be applied to find the “load curve most like all the others.” For example, the k-means method of cluster analysis can be used to identify one or more curves which have, individually, the most “average” peak load, variation rates, energy usage, and daily curve shape.

27. Sampling Rate Influences Load Duration Curve Shape

Load duration curves will appear different depending on the sampling rate of the load data, too, as shown in Fig. 24. Since data sampled at faster rates “sees” non-coincident needle peaks, it yields load duration curves that reflect that load behavior. Fig. 24 shows annual load duration curves for Fig. 12A, based on 5- and 60-minute demand period sampled data.

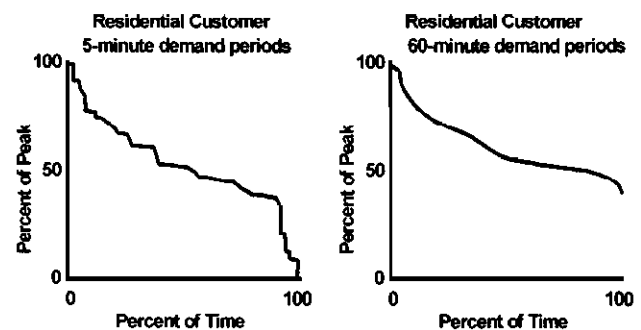

Fig. 24—Load duration curves of single residential customer (e.g., Fig. 12A) based on two sampling rates.

IV. DISTRIBUTION LOSSES ARE NOT PROPORTIONAL TO DEMAND SQUARED

One result of the coincidence behavior and sampling issues illustrated in this chapter is that the load-related losses on a power distribution system generally do not correspond to the square of the metered demand. The difference is due to interaction of demand sampling with the coincidence effects of the loads being served. Fig. 25 illustrates an extreme case, in which losses are a purely linear function of measured demand. The water heater operates for 15 minutes during the hour from 6 to 7 AM, and 30 minutes in the hour from 7 to 8 AM. Demand measured on an hourly basis doubles. Electrical losses in the wiring serving this water heater also double. They do not quadruple (as they would if losses varied as the square of demand) because the peak load in every demand interval is the same: as the demand changes from hour to hour, only the load factor changes.

In the extreme case shown in Fig. 25, losses in the line serving only the water heater, are a purely linear function of demand. This will be true regardless of the demand period intervals. Whether measured and compared on a minute, hour, day, or annual basis, losses are a linear function of demand.

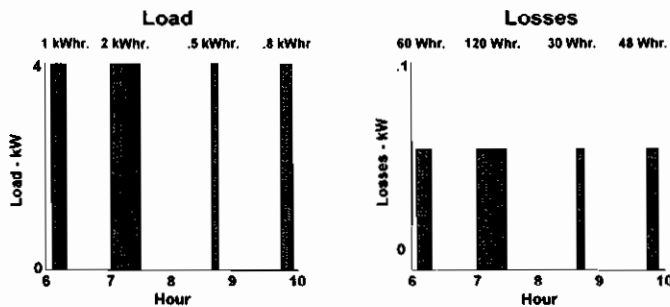

Fig. 25—Load of a water heater over a four-hour period (left) and the losses that result in the line serving it (right).

Load behavior at the service (LV) level is seldom the perfect “all or nothing” on-off load situation depicted in Fig. 25, but neither is the relationship between losses and load an “I²R” relationship. Observed losses vs. demand behavior generally falls somewhere between two extremes characterized by fundamentally different behavior of the load:

Losses are a linear function of demand. In such cases, the peak load is identical in every demand period and load factor changes from one demand period to another.

Losses are a squared (quadratic) function of demand. The losses’ factor remains constant in each demand period but peak load varies in proportion to demand.

The exact nature of the losses vs. demand relationship observed in any situation will depend on the load curve itself, the demand period with which load and losses are measured, and possible errors in the monitoring and recording of the data. Fig. 26 shows three examples of losses vs. demand measurements on the distribution system. In all three, the observed losses vs. demand relationship lies within an envelope defined by the two extremes – linear and squared behavior.

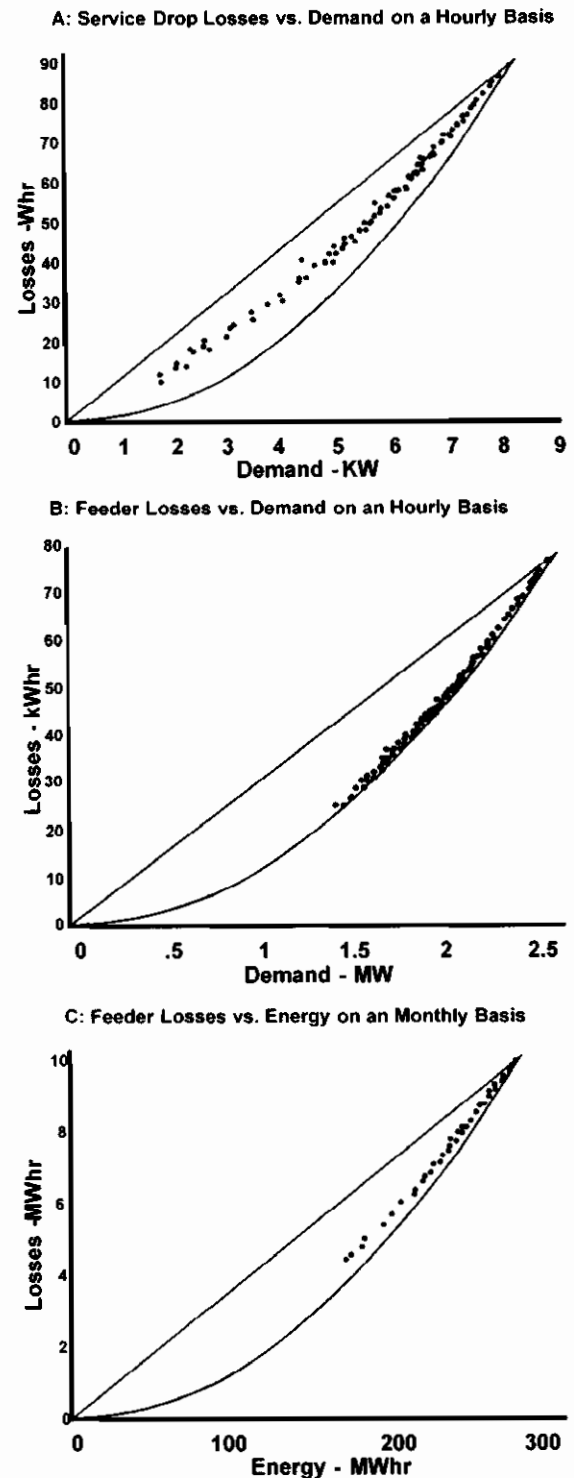

Fig. 26—A: Hourly losses vs. hourly demand over a one-week period for the secondary circuit/drops serving one of the 282 homes in a neighborhood served exclusively by a single distribution primary feeder. Lower (curved) line indicates a squared losses vs. demand relationship, upper (straight) line indicates a linear relationship. B: Hourly load-related losses vs. hourly demand for the 12.47 kV distribution feeder serving these 282 homes. C: Monthly load-related losses vs. monthly energy (this can be converted to “monthly demand by dividing energy by 731 hours/month) for the same feeder over the same period.

28. Relationship Between Losses and Demand

Usually, electrical losses are modeled as a function of demand with an equation fitted to measurements taken during selected periods (e.g., the data in Fig. 26). Most often, the function used estimates hourly losses as a function of hourly demand, using the maximum recorded hourly demand, and maximum recorded hourly losses as factors in the computation. Either of two functional representations are often used. As applied to hourly data, they would be:

$$\text{Losses}(h) = L_{\max} \times \left(a \times D(h)/D_{\max} + b \times (D(h)/D_{\max})^2 \right) \quad (6)$$

$$\text{Losses}(h) = L_{\max} \times (D(h)/D_{\max})^e \quad (7)$$

Where h indicates the hour,

D(h) is the demand observed in hour h,

D_{max} = maximum recorded hourly demand

L_{max} = losses during maximum demand hour

a + b = 1

e is a value between 1.0 and 2.0

The values a and b in equation 6 are essentially the same as the “a and b factors” used in traditional computations of losses factor from load factor.² They represent the extent to which losses behave in a linear, or squared, manner, respectively. Where losses are a linear function of load, a = 1 and b = 0, and the value e in equation 7 would be 1.0. Where losses have a squared relationship to demand, a = 0, b = 1, and e = 2.0.

Significant “non-squared” losses behavior on distribution systems usually occurs in the equipment that serves individual customers with small loads. The most extreme “non-squared” losses vs. demand behavior that is routinely encountered is a single household load, as shown in Fig. 26A (data is taken from the same load as in Fig. 12A. This is the losses vs. load situation for the service drops leading to this single house.

As the measured hourly demand in Fig. 12A varies, both its peak load and load factor vary roughly in proportion to one another. As a result, hourly losses vs. demand behavior is a mixture of the two extremes discussed above. Modeling of hourly losses as a squared function of hourly demand (a = 0 and b = 1 in equation 6, or e = 2.0 in equation 7) gives 35% average absolute error. Error is 13.5% when using 15 minute intervals. Modeling of the losses as a linear function of demand gives roughly twice these levels of error (almost all distribution losses behavior is closer to squared than to linear).

Usually, proper selection of a, b, and e coefficients can cut error by about 3/4. Use of a = .33 and b = .66 in equation 6 minimizes average absolute error, reducing it from 35% to 8.9%. Use of e = 1.51 in equation 7 similarly minimizes error, at 9.1%. The two equations provide different estimates on an hourly basis (with an average absolute difference of 4%) but are roughly equal in overall modeling accuracy. When using quarter-hour demand periods in this example, a = .24, b = .76, and e = 1.6 minimizes average absolute error, at less than 5%.

The load curve shown in Fig. 12A is one of 282 residential loads in a neighborhood served by a 12.47 kV feeder. Fig. 26B

shows the losses vs. demand data for this feeder, on an hourly demand period basis. The relationship appears much closer to squared than when the individual customer data was examined on the same hourly basis (Fig. 26A). Error in estimating losses as a function of demand occurs with a = .07, b = .93, and e = 1.91. (A larger value of b, and a value of e closer to 2, indicates a more “squared” relationship). *Generally, losses vs. demand behavior for equipment serving large groups of customers appears less linear and more quadratic (squared) than for smaller groups.*

In Fig. 26C, the feeder’s losses and energy (essentially the same as demand, demand = energy/173.33 hr./mth.) are compared on a monthly basis, instead of the hourly basis used in Fig. 26B. The observed relationship between losses and demand is much more linear than when hourly intervals were used to analyze the same load: error is minimized with a = .41, b = .59, and e = 1.52. The monthly demand period is much longer than the major cycle periods of the feeder’s load (daily and weekly variations). *Generally, losses vs. demand behavior appears more linear if longer demand intervals are used in the analysis.*

29. Mean Error in Estimating Loads

Representation of losses as a squared function of demand in equations like 6 and 7 usually results in *underestimation* of the average level of losses. Note the plotted lines, representing linear and squared losses behavior in Fig. 26. The curve representing losses as a function of demand squared is lower in all cases than the measured losses. The line representing losses as a linear function of demand is uniformly higher than any of the losses’ measurements. This is always the case when using losses estimation equations such as 6 or 7, calibrated against peak period demand and the values D_{max} and L_{max}.

Generally, if the long-term performance of a load analysis and prediction equation is to overestimate losses, then it is too linear in the calibration of its a and b, or e terms, regardless of the level of its average absolute hourly error. Similarly, if it consistently shows a bias toward underestimating the amount of losses over many demand periods, then it has been calibrated as too quadratic, even if it is giving satisfactory average error on a demand-period basis.

TABLE 6—COEFFICIENTS FOR LOSSES VS. DEMAND ON AN HOURLY DEMAND PERIOD BASIS AS A FUNCTION OF SYSTEM LEVEL

Level of the System	Average Equipment		Best fit*	
	Demand - kW	# custs.	b	e
Transmission	140,000	23,000	.97-1.0	1.95-2
Sub-transmission	42,400	6,900	.95-1.0	1.93-2
Substation	13,400	2,200	.90-.98	1.9-2
Feeder trunk	4,300	700	.90-.95	1.9-2.
Feeder branch	800	130	.85-.92	1.8-1.9
Lateral	120	19	.87-.90	1.7-1.8
Service Xfrmr.	34	5.5	.83-.88	1.6-1.8
Service circuits	17	2.7	.72-.80	1.5-1.7
Service drops	6.2	1.0	.66-.75	1.4-1.6
Total Dist. system	all	all	.75-.87	1.6-1.8

* Note: a = 1-b

² For example, see *Electric Utility Distribution Systems Engineering Reference Book*, Westinghouse Electric Company, 1959, page 28.

30. Modeling Losses on the Distribution System

The relation observed between losses and demand on a T&D system will depend on the customer load behavior, the measuring and recording equipment being used, and the demand period length of the recording and analysis. Generally, coincidence and demand period affect results:

1. *Coincidence.* Equipment that serves small groups of customers, exhibits more linear losses vs. demand behavior (higher ratio of a/b ; lower e) than equipment with many customers downstream. For example, the single customer hourly data shown in Fig. 26A is much more linear than that for the group of 282 customers in Fig. 26B. The two plots show essentially the same load type, observed on the same (hourly) demand period basis. *Losses vs. demand for coincident load situations is closer to quadratic. For non-coincident situations it is usually closer to linear.*

Thus, the best values of a and b , or e , to estimate losses as a function of demand on an hourly basis, will depend on the level of the system being modeled. Table 6 gives typical values for b and e on power systems in North America.

2. *Demand period length.* The losses vs. demand relationship shown in Fig. 26A, for the service drops leading to a household like that shown in Fig. 12A, is a mixture of linear and squared behavior when sampled on an hourly demand basis. The hourly sampling rate is much longer than the natural on-off cycles of many of the major appliances (see sub-section 13 of this chapter). The losses vs. demand relation would appear to be nearly a perfect squared relationship if evaluated on a minute by minute basis (not shown).

Similarly, losses vs. demand data for the feeder has a considerable non-quadratic behavior when viewed on a monthly basis (Fig. 26C), because the demand periods are much longer than the daily and weekly load swings normally seen in the load, as well as the three- to six-day weather-front cycles which often affect the weather-sensitive portion of these loads. Hourly demand periods (Fig. 26B) are much shorter than these cycles, and observed losses vs. demand behavior at this demand period length is very nearly a perfectly squared relation. *Short demand periods produce more quadratic losses vs. demand behavior; while long demand periods result in a relationship that appears more linear.* "Short" and "long" as used here are relative to the dynamic cycles or periodicities of the load behavior.

Therefore, the overall losses vs. demand relationship depends on both the equipment level of the system being studied (amount of load or customers downstream) and the demand period being used for data and analysis. Fig. 27 shows values of b (for equation 6) that work well as a function of level of the system and demand period in a typical residential area in the southwestern United States. The qualitative behavior shown occurs on all power systems.

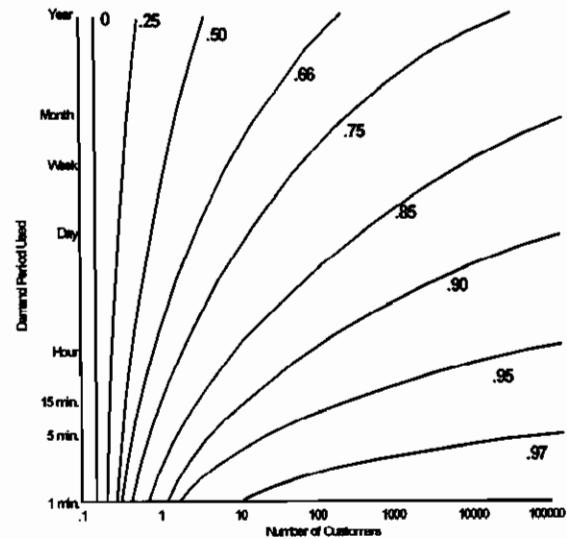

Fig. 27—Values of b for equation 4 that give minimum error in estimating losses from demand for residential load in a utility system in the southwestern United States. Losses vs. demand behavior on other systems will differ quantitatively from the values shown here, but is generally qualitatively similar. "Number of Customers" less than 1 refers to individual appliances loads and household circuits.

31. Losses vs. Demand on the Entire Distribution System

From 25% to 66% of distribution losses occur on portions of the distribution system near the customer, portions that deviate significantly from a "squared" losses vs. demand relationship. As a result, the overall losses vs. demand relationship for an entire distribution system will usually deviate noticeably from a squared relationship. The quantitative relationship varies from one system to another depending on customer loads, system equipment types, and layout and design used in the primary and service levels. Generally, b is in the range of .75 to .88, behavior is more quadratic than linear, but sufficiently non-quadratic that significant error (on the order of 25%) results in predicting hourly losses from demand if a purely squared relationship is assumed.

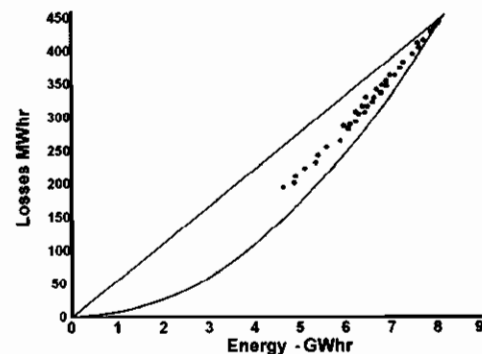

Fig. 28—Monthly energy vs. load-related losses for the system that includes the feeder and loads shown in Fig. 26. This includes losses on feeders, laterals, and secondary/service drops. $b = .78$

VI. T&D SYSTEMS ARE BUILT TO SATISFY CUSTOMERS, NOT LOADS

32. Quantity, Quality, and Value

The diverse types of consumers purchasing electric power from the distribution system have different uses for the power they buy, different needs for quantity (amount of power purchased), and needs for quality (continuous availability, tight voltage regulation), and different dispositions to pay a premium price to get exactly what they need. The *value* a particularly consumer places on electric power is a function of his or her needs for electricity, primarily as defined by the economic or personal value of the end-use (i.e., watching television and keeping food cool, stamping sheet metal into equipment cases, operating a cash register/inventory system), and as fashioned by the demands of the appliances used to convert electricity into the end-use.

The major element of customer quality is *availability* of sufficient quantities of power. Quality can be as or even more important than quantity in determining the customer value, but the important point is that both quantity and quality are major factors to be considered in determining how to maximize customer value. Two common residential appliances that illustrate the opposite extremes in these two “Q dimensions” that can exist among customers. These are an electric water heater and a personal computer.

A typical 50-gallon storage water heater has a connected load of 4,000 watts, and a coincident contribution to system peak of about 1,100 watts. This is a relatively high demand for quantity of power as compared to most household appliances (typically only central air conditioners or heaters use more power). Power to a water heater can be interrupted routinely for several hours at a time (and often is under peak-shaving load control programs). Such interruptions make little impact on its value to the customer, because it can supply reasonable quantities of hot water from its storage tank during power interruptions. In addition, its end-use performance is virtually immune to voltage sags, surges, and even significant long term variations in supply voltage. Thus, while a water heater has a high demand for quantity, it has a low demand for power quality.

A personal computer exhibits demand characteristics exactly the opposite of the water heater’s. A typical PC has a connected load of about 180 watts, and a contribution to coincident peak of the same magnitude. But while its connected load is one twentieth, and its peak demand only one sixth of the water heater’s, its demand for quality is much higher. Measured as the time it can go without power while continuing to perform its end-use function, a PC is about 15,000 times more sensitive to power continuity problems than a water heater. It is also vastly more sensitive to voltage sags and surges, and long-term changes in voltage.

Largely because of the different needs of their appliances and equipment, and the difference values of the net end-use products, electric customers vary greatly in their demand for electric power quality. Fig. 29 gives five examples of “cost of interruption” value of electric customers. The cost vs. time functions shown are not typical, because there is no typical need for power quality, just as there is no typical quantity of power requirement that suits all customers. In general, commercial and industrial consumers have a higher demand for both quantity and quality of power than residential consumers.

In a competitive electric power industry, and a world where attention to quality is taken for granted in many other industries, power system engineers should anticipate increasing levels of attention on quality of power delivered. This does not necessarily mean that quality must be or will be improved. Cost is an important element of value, and a large portion of consumers in most power systems would prefer to pay a lower price for power, even if that means they must sacrifice some amount of power quality in return. The important point is that like quantity of power, quality is an important attribute. As it is with quantity, it is possible to overbuild or underbuild a power system with respect to the amount of quality that needs to be delivered. The challenge facing power engineers is to design the lowest cost system that can deliver the required levels of both, and no more.

VI. GROWTH OF ELECTRIC LOAD AND T&D CAPACITY REQUIREMENTS

33. Spatial Distribution of Load Defines T&D Needs

Electric load is not evenly spread throughout a power system’s service area, but instead, non-homogeneously distributed, with high load density in some areas and no load in others, as shown in Fig. 30. This is due to the heterogeneous distribution of land use and activity within any city, town, or rural region – some areas are more densely settled and active than others. Not shown in Fig. 30, but an important fact in determining electric load, is that customer class varies by location, too. Some areas of a system are nearly entirely residential, others commercial, or industrial, and others mixed.

The load map in Fig. 30 shows some very common characteristics of spatial load distribution, shared by most large metropolitan areas: high load density in the urban core, gradually decreasing toward the periphery, with tendrils of higher load density following major transportation corridors.

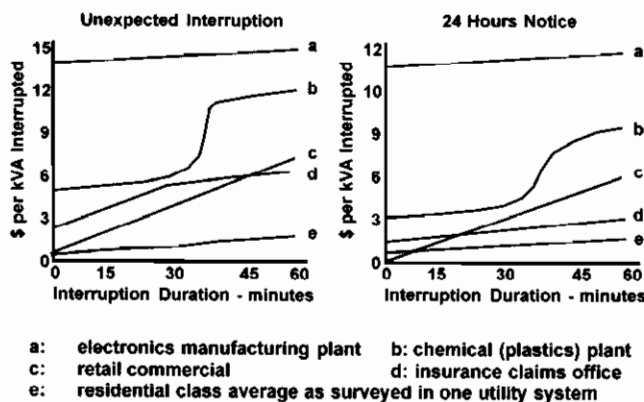

Fig. 29—Cost vs. interruption duration when an interruption is unexpected (top), and when one day’s notice is given (bottom).

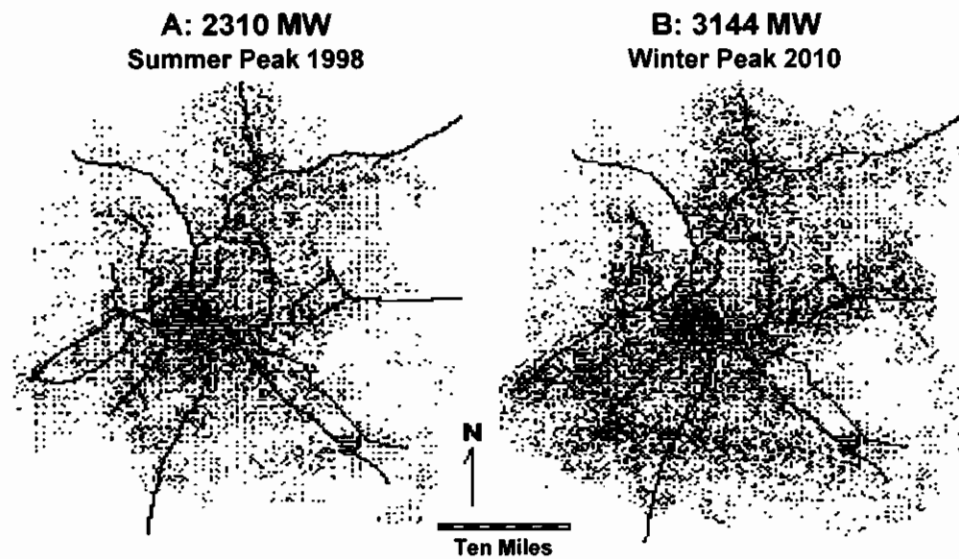

Fig. 30—Spatial distribution of electric load for a city of about 1 million population in the eastern United States. Shading indicates load density. Lines indicate major roads. At the left, 1998 winter peak load. At the right, a forecast of peak load for year 2010, based on projected trends in load density, customer count, area development, peripheral expansion, and end-use loads. The city is projected to grow both up and out during the 12-year period. Some interior areas are projected to increase in load density, but others are not, and load density decreases in a few areas. Load develops in previously vacant areas, particularly along the south periphery.

The load maps in Fig. 30 outline the mission of the T&D system for the region shown. In the year 1998 it must deliver 2,310 MVA of electric power in the geographic pattern shown. Its ability to do so reliably and economically is the major measure of its performance as a power delivery system.

34. Load Density Varies With Location

Fig. 30 illustrates how load density varies as a function of location within a power system. Analysis of load in terms of kW/acre or MW/square mile is a convenient way of relating it to local T&D capacity needs and is often used in power delivery planning. Load density is an important aspect of T&D planning, since the capacity and location requirements of T&D equipment depend on local load characteristics, not system averages. Typical ranges of values for urban, suburban, and developed rural areas are given in Table 7. The values shown are typical, but values specific to each particular system should be obtained by measurement.

TABLE 7—TYPICAL LOAD DENSITIES FOR VARIOUS TYPES OF AREAS

Type of Area	Construction	kVA/acre
Urban	Dense, high rise	600 - 3000
	Low rise office/prof.	50 - 750
	Retail	50 - 300
	Residential - dense	10 - 60
Suburban	Retail	10 - 100
	Office/Ind. Park	5 - 50
	Residential	2 - 25
Rural	Residential	3 - 15
	Agricultural - non irrigation	005 - .1
	Agricultural - irrigation	25 - 3

35. Growth Drives System Expansion

Fig. 30B shows the projected load 12 years later than Fig. 30A, based on a detailed evaluation of economic growth of the region, land availability, demographic and zoning factors, and expected changes in per capita and end-use loads. After this 12-year period of growth, the T&D system will be expected to deliver 3,144 MW in the pattern shown. During the intervening 12 years, additions and changes to the system must be made so that it can grow along with the load. This load growth is the motivation for the equipment additions, and the expansion budget will be well spent only if the equipment is located, and locally sized properly, to match the evolving load pattern in Fig. 30B.

Comparison of Fig. 30A and Fig. 30B reveals several characteristics of load growth as it affects T&D systems:

1. Previously vacant areas develop load, e.g., the swath of load growth across the entire southern frontier of this city between 1998 and 2010. Entirely new parts of the system must be built into these areas.
2. Some vacant areas do not grow. For whatever reason, some areas remain vacant, often because of local covenants or because they are for public use (parks, etc).
3. Load in some developed areas increases in load density, perhaps substantially. Examples in Fig. 30 include the urban core and some areas in outlying areas.
4. Load in some developed areas remains constant, or falls slightly due to increasing appliance efficiency in areas that otherwise remain unchanged (no new building construction or population increase).

The difference between Fig. 30A and Fig. 30B represents the challenge facing this system's T&D planners. They must make additions whose equipment types, capacities, locations, and interconnections to the existing system result in a "12-years hence" system that can reliably and economically serve the pattern shown.

36. Two Causes of Load Growth

Two simultaneous processes create electric load growth or change, both at the system and at the distribution level. Increases in the number of customers in the utility service area, and increases in the usage per customer cause electric load to grow. No other process causes load growth: If the electric demand on a power system increases from one year to the next, it can be due only to one or a combination of both of these processes:

- 1) *New customers* are added to a system due to migration into an area (population growth) or electrification of previously non-electric households. Customer growth causes the spread of electric load into areas that were "vacant" from the power system's standpoint.
- 2) *Changes in per capita usage* occur simultaneously and largely independently of any change in the number of customers. In developing economies this is driven by the acquisition of new appliances and equipment in homes and businesses. In developing nations, per capita load growth often decreases, due to improving appliance efficiency.

In cases where *per capita* consumption is increasing, it is usually due to major shifts in appliance market penetration. For example, the percentage of homes and businesses using electric power to heat the interior of buildings may increase from 20% to 26% over a decade. In such a case, even if appliance efficiency is increased slightly, electric load will grow.

37. Spatial Load Growth and the "S" Curve Characteristic

When viewed from a total system basis, a growing power system generally exhibits a smooth, continuous trend of annual peak load growth. Given a healthy economy, and corrected for variations due to weather, the load in the region will simply continue to grow at a continuous rate.

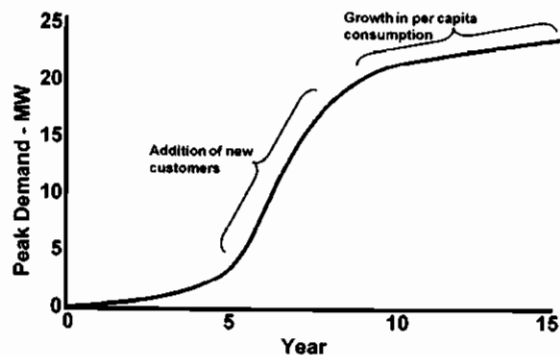

Fig. 31—The "S curve" has an interval of high growth rate sandwiched between two periods of lower rate growth.

By contrast, growth in any relatively small geographic area is not a smooth continuous trend from year to year. Instead, it follows the Gompertz curve, commonly referred to as an "S" curve, shown in Fig. 31. The "S" curve is the basic behavior of load growth as it affects T&D equipment, such as in feeder and substation areas. Nearly every small area within a large power system has a load growth history similar to that shown in Fig. 31, for a very simple reason: *land fills up*.

The S curve has three distinct phases, periods during the local area's history when fundamentally different growth dynamics are at work:

Dormant. The time "before growth", when no load growth is occurring. The small area has no load and experiences no growth: growth "hasn't arrived yet."

Growth ramp. During this period growth occurs at a *relatively* rapid rate, usually due to new construction.

Saturation. The small area is "filled up" – fully developed. Growth may continue, but at a very low level compared to that during the growth ramp.

What varies *most* among the thousands of small areas in a large utility service territory is the *timing* of their growth ramps. Seen in aggregate over several thousand small areas, and the overall system load curve looks smooth and continuous because there are always roughly the same number of small areas in their rapid period of growth. The continuous year-to-year trend for the whole system is due to diversity in the timing of when areas grow: any one area grows for only a short time, but new areas of growth are constantly being added to a growing city, so as a whole, it grows continuously.

Evidence of historical "S" curve load growth exists in every city. Most people can identify areas of their home town or city that developed in the 1960s, the 1970s, the 1980s, or the 1990s. The buildings in these areas are of a common age, because all were built during a "burst" of development in that area, at that time.

38. Relation of Load Growth Causes to "S" Curve Shape

These two causes of load growth are tied to different parts of the "S" curve characteristics, as shown in Fig. 31. The growth ramp occurring over a short period of time is due to new customers in the area. The slow, steady growth thereafter is due to increasing per-capita usage by the customers in the area. In some cases, the slow, steady trend is a reduction over time, due to improving appliance efficiency.

39. Growth Behavior as a Function of Spatial Resolution

Planners of the power supply to an entire region have no need of specific geographic information on the locations of loads, or the areas which are or are not growing rapidly. They have no need of spatial resolution in their planning, for their goal is to plan and operate sufficient power for the entire region.

T&D planners, on the other hand, do have a need for locational information in the planning, routing, design, and

operation of their system. Facilities are utilized more efficiently if they are sited correctly. The need for locational detail in planning and engineering is called *spatial resolution*.

Spatial resolution requirements vary depending on application: feeder planning requires more detail on and is more sensitive to changes in the location of loads, than transmission planning. Table 8 gives typical range of spatial resolutions (knowledge of load as a function of location) that work well in T&D planning. The table indicates that knowledge of how load density, and load growth are usually needed to match equipment locations so that economy and reliability are maximized to the load. Resolution as used in the table refers to the width of a square area used for load studies, and within which reliable information on load locations is not available.

TABLE 8—TYPICAL SPATIAL RESOLUTION (LOCATIONAL DETAIL) FOR PLANNING AS A FUNCTION OF SYSTEM LEVEL

Level of the System	Typical Equipment Capacity – kVA	Spatial Resolution - miles
System	500,000+	none
Transmission (>230 kV)	500,000	none
Transmission (>115 kV)	250,000	5.0
Sub-transmission (<115kV)	75,000	2.0
Substation	30,000	.70
Feeder system	6000	.20
Feeder branches & Lateral	600	.06
Service Level	125	.03

Due to the “S” curve growth dynamics described earlier, observed load growth behavior varies as a function of the spatial resolution used in load analysis and planning. *Load growth behavior will appear to be different simply depending on the small area size used to collect and analyze growth.*

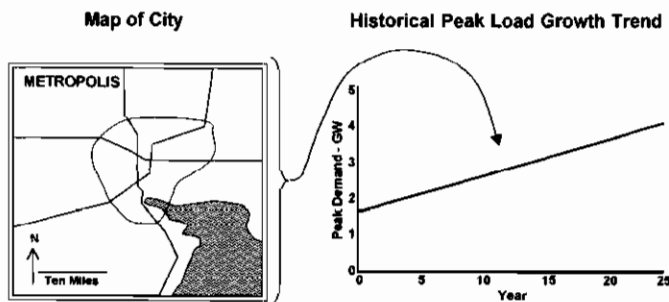

Fig. 32—Annual peak load of a large city over a twenty-five year period, after correction for weather and other anomalies.

To understand this phenomenon, and to see how and why it occurs, it is useful to consider a diagram of the annual peak load of a growing city of perhaps 2,000,000 population, as illustrated by Fig. 32. For simplicity's sake, assume that there have been no irregularities in the historical load trend due to weather, changing economy, or shifts in service territory boundaries. This leaves a smooth growth trend, one that shows

steady annual load growth over a long period of time, as shown. Except for weather and economy, many cities have in fact grown steadily in this manner: Denver, Phoenix, Indianapolis, Bangkok Caracas, and Rabat, to name just a few.

Imagine dividing the metropolitan area illustrated in Fig. 32 into quadrants. Each quadrant would still be very large (in a city like Atlanta or Houston, nearly a thousand square miles). If the exact load history of each quadrant could be plotted, all would be slightly different in amount of load and rate of growth, but all would still have a fairly smooth, continuous trend. This is shown in Fig. 33.

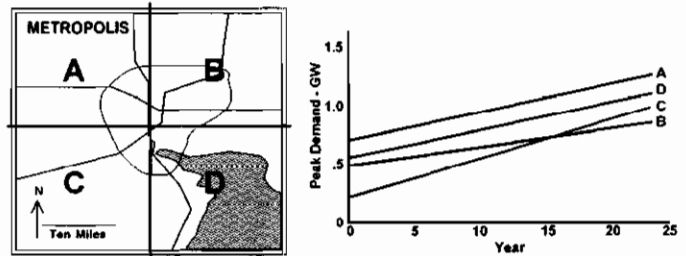

Fig. 33—Quadrants also display smooth, long-term growth trends.

But if this process of hierarchical sub-division continues, splitting each sub-quadrant into sub-sub-quadrants, and so forth, “S” curve load growth trends will begin to be discernible as the common characteristic of growth, when the sub-division reaches a size of about 16 square miles (square areas 4 miles, or 6 km, on a side). Most long-term trends at this spatial resolution would begin to display slight “kinks,” something like those shown in Fig. 34 – an “S” curve, rather than a smooth, long-term steady growth pattern.

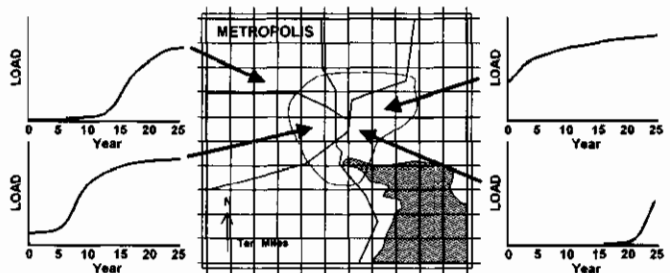

Fig. 34—Areas of about 16 square miles (areas 4 miles on a side) display discernible “S curves” load growth behavior. The city grows at a steady rate (Fig. 32) because the growth ramps of different areas occur at different times.

Carrying the sub-division to the extreme, one could imagine dividing a city into areas so small that each contained only one building. At this level of spatial resolution, annual peak load growth would be characterized by the ultimate “S” curve, a step function. Although the timing would vary from one small area to the next, the basic load growth history of a small area of such size could be described very easily. For many years the area had no load. Then, usually within less than a year, construction started and finished (for example's

sake, imagine that a house is built in this very small area), and a significant load established. For many years thereafter, this annual load peak of the small area varies only slightly – the house is there and no further construction occurs.

The quantitative behavior of the “S curve” growth characteristics will depend somewhat on the spatial resolution (small area size used). There are three important interactions with between growth characteristics and spatial resolution.

1. *The “S” curve behavior becomes sharper as the service territory is subdivided into smaller and smaller areas.* The smaller the small areas being studied (the higher the spatial resolution) the more definite and sharp the “S” curve behavior exhibited, as shown in Fig. 35. Quantitative behavior of this phenomena depends on growth rate, demographics, and other factors unique to a region, and varies from one utility to another. Qualitatively, all utility systems exhibit this behavior: “S” curve load trend becomes sharper as area size is reduced.
2. *As the utility service territory is subdivided into smaller and smaller areas, the number of small areas that have no load and will never have any load increases.* When viewed on a square mile basis (640 acre resolution) there will likely be very few “completely” vacant areas in a city such as Phoenix or Atlanta or Caracas: square miles that are completely devoid of electric load.

But if examined on an acre-parcel basis, a significant portion of land, perhaps as much as 15%, will be “vacant” as far as electric load is concerned, and will stay that way. Some of these vacant areas will be inside city, state, or federal parks, others will be wilderness areas, cemeteries or golf courses, and many other merely ‘useless land’ – areas on very steep or otherwise unusable terrain.

3. *The amount of load growth that occurs within previously vacant areas increases as small area size decreases.* If the load growth of a city such as Denver or Houston were analyzed over the period 1980 to 1990, using a small area size of nine square miles (areas three miles to a side), almost all of the load growth during the period would have occurred in areas that had noticeable amounts of load in 1980.

By contrast, if those same regions were examined at a 2.5 acre spatial resolution (small areas 1/16 mile to a side) nearly half of the decade’s load growth would be found to have occurred in small areas that had no significant load in 1980 – areas that were vacant.

Thus, the observable dynamics of load growth appear somewhat different depending on the amount of *where* detail used in the load analysis. *As spatial resolution is changed, the character of the observed load growth changes, purely due to the change in resolution.*

At low resolution (i.e., when using “large” small areas) load growth appears to behave as steady, long-term trends in areas with some load already established. Few, if any areas, are completely devoid of load. By contrast, if examined at high

spatial resolution, growth is usually a short, intense period of development. It usually happens in areas where there was no previous load, and it does not always occur – many areas stay vacant.

The three changes in growth character discussed above occur *only* because spatial resolution of data collection and analysis changes. The character of the load growth itself does not change, only the way it *appears* to the planner. By asking for more spatial information (the “where” of the T&D planning need) the very appearance of load growth itself, changes.

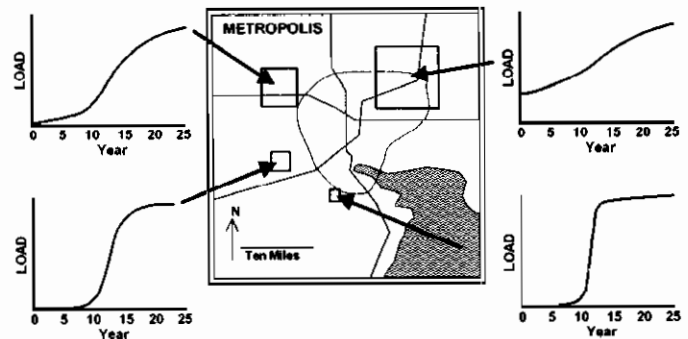

Fig. 35—As small area size for the load growth analysis is decreased, the average small area load growth behavior becomes more and more a sharp “S” curve behavior. (vertical scales of the four plots shown are different, with the full range in each case indicating 100% of the fully-developed load level).

40. Regions “Fill Up” In A Discontinuous Manner

Fig. 36 shows another way to examine the “S” curve growth behavior at the distribution level, and reveals another implication of this growth behavior. Shown is the growth of electric load in a region of about 24 square miles on the outskirts of a large, growing metropolitan area, over a 12-year period. Individual land parcels within this area generally follow the “S” curve growth behavior pattern, with a growth ramp (period from 10% to 90% of eventual saturated load) of about three years at the ¼ square mile resolution. The complete area, however, has a growth ramp of about 15 years.

The development of load within this area is geographically discontinuous, with the timing of various parcels displaying a somewhat random pattern. While growth usually develops from the southwest outward (this area is on the northeast edge of the metropolitan area), the timing of when a parcel of land begins to develop is somewhat random. Growth does not develop as a smooth trend outward, but instead appears to be a semi-random process. Once load has filled up one parcel, it does not automatically proceed to the next in line, but may jump to another nearby area. Thus, early in the process of growth for this whole area, some parcels develop to saturation on its far edge early in the process. *The most unpredictable aspect of small area load growth is the exact timing of parcel development.*

In contrast, experience and research has shown *that the eventual load level in most small areas can be predicted fairly well, as can the expected duration of growth ramps* (see Willis,

1996). However, the exact timing of growth appears to be somewhat random, at least as viewed from *a priori* information likely to be available to the planner. Implications for T&D expansion are clear. The system cannot be extended incrementally outward from the southeast as load grows. Instead, substation siting and feeder expansion must deal with delivering “full load density” to an increasing number of neighborhoods scattered over the entire region, that develop geographically into a higher overall density. This means that full feeder capability (maximum designed load and maximum designed distance) may be needed far sooner than predicted by the “gradually increasing density” concept.

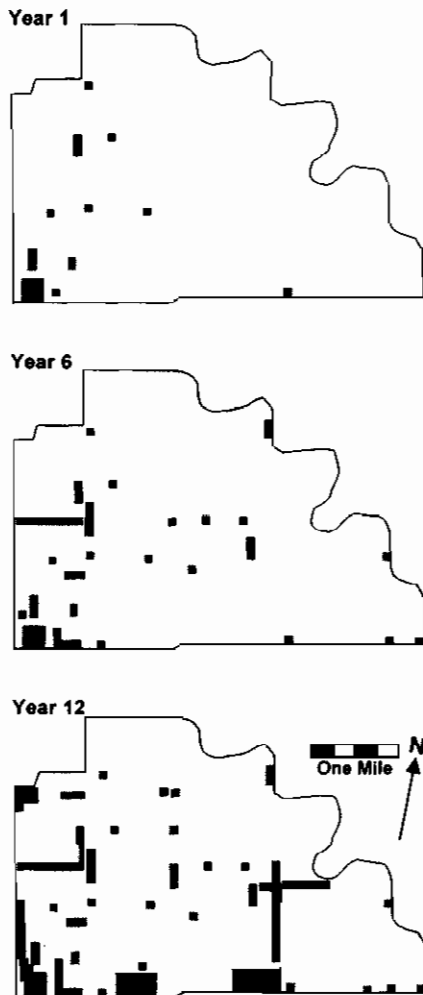

Fig. 36—Load grows as developing parcels of land. As a region fills in with load, individual parcels develop very quickly, but often leave vacant areas between them. The utility may have to build a majority of the primary feeder lines that will be needed eventually, long before a majority of the growth has developed.

Such expansion is difficult to accomplish economically: feeders must be extended over much of this area early in the 12-year period, so the utility can serve the widely scattered pockets of high load density. Great capacity is not needed at that time, because the overall load is not high. However, a good portion of all the routes eventually needed is required

early, in order to reach these disparate locations. An economic dilemma develops because the utility will eventually need a good deal of capacity in these routes when the load fills in the area, but planners do not want to incur the cost of building now for load levels not expected for 10-12 years. The challenge is to find a way to expand the system without building a majority of the routes early, or having to build many long routes with higher capacity than will be needed for years.

41. “Putting Out Fires” Is the Norm in T&D Expansion

T&D planners often speak about “putting out fires” – having to develop plans and install equipment and facilities on a tight time schedule, starting at the last moment, without proper time to develop comprehensive plans or coordinate area development overall. A point illustrated here is that the load growth aspect of this situation is the norm: rapid growth that starts with little warning, fills in an area relatively quickly, and then moves elsewhere, not only happens on a regular basis, but is the *normal mechanism of growth*. The “S Curve” growth characteristic, its tendency to be sharper in smaller areas, and the semi-random, discontinuous pattern of load development described above, are very general characteristics that affect all power systems. Load development in a small area almost always begins with little long-term warning, grows at a rapid rate to saturation, and then moves to other areas, usually near by, but often not immediately adjacent.

This growth characteristic is the basic process that drives T&D expansion, equipment additions, and the planning and engineering process. T&D engineers will never change the nature of load growth and development. The recommended approach is to develop planning, engineering, and equipment procurement procedures that are compatible with this process. These include:

- Master plan* development based on projected area development. As noted above, the eventual load density for any small area, and the overall pattern of development for a region, can be predicted with reasonable accuracy fairly far in advance. Thus, long range plans optimized to the expected pattern of development can be developed.
- Use of modular system layouts* for transmission, substations, feeders and service (LV) parts of the system, that permit modular expansion on an incremental parcel basis. Some types of layout are more expandable on a “fill in the parts” basis than others. In particular, the growing use of multi-branched rather than large-trunk feeder layouts is one reaction to this situation. Such feeders can be expanded on a short range basis, to cover a growing area as needed, yet still fit into an optimized long-range plan.
- Organization* of the planning, engineering, and construction process with short lead times for implementation. Given that a long-range master plan exists for an area, the key to success is a short start-up and lead time for engineering of the details and project implementation, once development begins.

REFERENCES

1. *Power Distribution Engineering – Fundamentals and Applications*, by J. J. Burke, Marcel Dekker, New York, 1994.
 2. *Trends in Distribution Reliability*, by J. J. Burke, ABB Electric systems Technology Institute, Raleigh, NC 1997.
 3. Urban Distribution Load Forecasting, final report on project 079D186, Canadian Electric Association, 1982.
 4. Research into Load Forecasting and Distribution Planning, report EL-1198, Electric Power Research Institute, Palo Alto, CA, 1979.
 5. DSM: Transmission and Distribution Impacts, Volumes 1 and 2, Report CU-6924, Electric Power Research Institute, Palo Alto, Aug. 1990.
 6. *Tutorial on Distribution Planning*, by M. V. Engel et al., editors, Institute of Electrical and Electronics Engineers, New York, 1992.
 7. *Edge City*, by J. L. Garreau, Doubleday, New York, 1991.
 8. Computer Speeds Accurate Load Forecast at APS, by A. Lazzari, *Electric Light and Power*, Feb. 1965, pp. 31-40.
 9. *Model of Metropolis*, by I. S. Lowry, Rand Corp., Santa Monica, 1964.
 10. Sensitivity Analysis of Small Area Load Forecasting Models, by J. R. Meinke, in *Proceedings of the 10th Annual Pittsburgh Modeling and Simulation Conference*, University of Pittsburgh, April 1979.
 11. Electrical Loads Can Be Forecasted for Distribution Planning,” by E. E. Menge et al., in *Proceedings of the American Power Conference*, Chicago, University of Illinois, 1977
 12. Computer Model Offers More Improved Load Forecasting, by W. G. Scott, *Energy International*, September 1974, p. 18.
 13. Load Forecasting Data and Database Development for Distribution Planning, by H. N. Tram et al., *IEEE Trans. on Power Apparatus and Systems*, November 1983, p. 3660.
 14. Load Forecasting for Distribution Planning – Error and Impact on Design, by H. L. Willis, *IEEE Transactions on Power Apparatus and Systems*, March 1983, p. 675.
 15. *Spatial Electric Load Forecasting*, by H. L. Willis, Marcel Dekker, New York, 1996.
 16. *Power Distribution Planning Reference Book*, by H. L. Willis, Marcel Dekker, New York, 1997.
 17. Some Unique Signal Processing Applications in Power Systems Analysis, by H. L. Willis and J. Aanstoos, *IEEE Transactions on Acoustics, Speech, and Signal Processing*, December 1979, p. 685.
 18. Spatial Load Forecasting – A Tutorial Review, by H. L. Willis and J. E. D. Northcote-Green, *Proceedings of the IEEE*, February 1983, p. 232.
 19. Comparison of Fourteen Distribution Load Forecasting Methods, by H. L. Willis and J. E. D. Northcote-Green, *IEEE Transactions on Power Apparatus and Systems*, June 1984, p. 1190.
 20. *Introduction to Integrated Resource T&D Planning*, by H. L. Willis and G. B. Rackliffe, ABB Guidebooks, ABB Power T&D Company, Raleigh, 1994.
 21. Some Aspects of Sampling Load Curves on Distribution Systems, by H. L. Willis, T. D. Vismor, and R. W. Powell, *IEEE Transactions on Power Apparatus and Systems*, November 1985, p. 3221.
 22. A Cluster-based V.A.I. Method for Distribution Load Forecasting, by H. L. Willis and H. N. Tram, *IEEE Transactions on Power Apparatus and Systems*, September 1983, p. 818.
 23. Spatial Electric Load Forecasting, by H. L. Willis, M. V. Engel, and M. J. Buri, *IEEE Computer Applications in Power*, April 1995.
 24. Forecasting Electric Demands of Distribution System Planning in Rural and Sparsely Populated Regions, by H. L. Willis, G. B. Rackliffe, and H. N. Tram, *IEEE Transactions on Power Systems*, November 1995.
 25. Short Range Load Forecasting for Distribution System Planning – An Improved Method for Extrapolating Feeder Load Growth, by H. L. Willis, G. B. Rackliffe, and H. N. Tram, *IEEE Transactions on Power Delivery*, August 1992.
-

APPENDIX

THIS appendix includes a number of tables of statistical transmission line data collected from numerous sources. These tables have been included because they have proved to be of considerable use in dealing with transmission line problems, and it was felt that they could be conveniently used by the reader in this form.

Table 1 gives practices regarding stability features of typical lines as tabulated in "First Report of Power System Stability" by an AIEE Subcommittee on Interconnection and Stability Factors (*A.I.E.E. Transactions*, 1937).

In addition, statistical data on the output and capacity of some of the larger power systems in the United States taken from the Federal Power Commission publications, *Statistics of Electric Utilities in the United States—1948 and Statistics of Publicly Owned Electric Utilities—1948*, are given in Table 2.

Important features of typical lines from the lightning protection point of view have been collected and tabulated by an AIEE Subcommittee on Lightning and Insulators. These tables, which appeared in the *A.I.E.E. Transactions* in 1939 and 1946 have been reproduced in the appendix as Tables 3 and 4.

Tables 5 and 6 and the included descriptive material have been added to facilitate derivation of equivalent circuits for power and regulating transformers from the impedance data usually furnished by the manufacturer.

Table 7 has been abstracted from "Equivalent Circuits of Power and Regulating Transformers" by J. E. Hobson and W. A. Lewis (Westinghouse Reprint 941).

TABLE 1—PRACTICES REGARDING STABILITY FEATURES†

	Los Angeles Bureau of Power & Light	Metropolitan Water District of So. California	Southern California Edison Co.	Pacific Gas & Electric Co.		Puget Sound Power & Light Co.		Southern Sierras Power Co.	Platte Valley Public Power & Irrigation Dist.
	Item I Boulder Dam- Los Angeles	Item I Boulder Dam Line	Item I Big Creek Line	Item I Tiger Creek- Newark	Item II Bucks Creek- Wilson	Item I Baker River Nos. 1 & 2	Item II Rock Island No. 1	Item I Boulder Dam Line	Item I North Platte- Columbus
A. Transmission									
1. Voltage, kilovolts.....	287.5	230	220	220	220	110	110	132	115
2. Distance, miles.....	267	237‡	240	109	185	67	134	222	218.5
3. Frequency, cycles.....	60	60	50	60	60	60	60	60	60
4. Power, kilowatts sent out	265 000	330 000‡	400 000	150 000	120 000	40 000	25 000	32 000	25 000
B. Circuit arrangement									
1. Number of circuits....	2	1	3	2	2	2	1	1	1
2. Intermediate switching stations.....	2	None	4	None	1	1	None	None	2
3. Load taken off at inter- mediate points, kilo- watts.....	None	None	135 000	None	None	None	None	None	12 000
4. Synchronous condenser, kva at intermediate points.....	None	None	None	None	None	None	None	None	8 000
5. Bussing arrangements									
a. Sending end.....	H.T.	H.T.	H.T.	None	None	None	None	None	L.T.
b. Receiving end.....	L.T.	H.T.	H.T.	None	None	None	None	None	H.T.
6. Grounding									
a. Sending end.....	Solid	Solid	Solid	Solid	Solid	Solid	Solid	Solid	Solid
b. Receiving end.....	Solid	Solid	Solid	Solid	Solid	Solid	Solid	Solid	Solid
C. Generator									
1. Kilovolt-amperes.....	Each 82 500	Each 82 500	15 units, total 397 000			39 000	66 668	40 000	2 units, each 14 500
2. Short-circuit ratio (or synchronous reac- tance percent).....	2.74	2.4	1.6					1.6	115.5
3. Transient reactance x_d' percent.....	17.5	17.5	22	27	27	23	30	26	32
4. Inertia constant H	9.5	4.7	3.74	4.1	4.1	4.05	4.45	3.8	2.05
5. Damper winding.....	Copper	Copper	None	None	None	Copper	Copper	Copper	Copper
D. Excitation system									
1. Exciter response, per unit—self- or pilot ex- citer.....	0.5 Pilot	0.5 Pilot	1.0 Pilot	1.5	1.5	240 volts/sec	200 volts/sec	0.5 Pilot	1.0 Pilot
E. Breakers and relays									
1. Breaker speed, cycles....	3	8	8-26	12	12	18	8	10	8
2. Relaying type.....	Carrier current and cross bal- anced between parallel circuits —3 cycles	Instantaneous overcurrent	Instantaneous overcurrent & simultan- eous carrier current on some lines	Overload & directional residual	(Same as item I)	Balanced current	High speed distance	Phase: In- duction impedance G'nd: direc- tional induction 16 (Min.)	Distance
3. Total time, cycles*....	6	8.5	8.5-31	13-14	13-14	27-54	9		9-10
F. Lightning protection									
1. Tower construction....	Steel	Steel	Steel	Steel	Steel	Wood pole H frame	Steel over mountains, rest is wood pole H frame	Steel	Wood pole H frame
2. Ground wires.....	2-50' spacing on 1 circuit towers —40.5 on 2 cir- cuit towers	None	2	None	None	None	None	None	None
3. Counterpoises.....	Continuous— 2 wires per tower line, cross connect to ad- jacent towers.	None	None	None	None	None	None	None	None
4. Insulators.....	Susp: Single—24 10"x5" units Deadend: Double, 22 10½"x6" units	Susp: 13-10" diam., 5¾" spacing Deadend: 15-same	Susp: 12-10" units Deadend: 13-double, same	13 5½" units Semi-fog sec- tion, 14 5½" units Fog section, 20 5½" units	14 5½" units	Susp: 6-10" units Deadend: 7-same	(Same as item I)	Susp: 9-10" units Deadend: 10-same	Susp: 7-10" ×5¾" units Deadend: 8-same
5. Lightning arresters....	Terminal Sta.—Yes Switching Sta.—No	None	None	None	None	Yes	Yes	Yes	Yes

* Note—In certain cases of sequential tripping, time given applies to first breaker only.

† From the "First Report of Power System Stability," A.I.E.E. Subcommittee on Interconnection and Stability Factors, *A.I.E.E. Transactions*, pp. 261-282, Feb. 1937.

‡ Editors Note: 84 miles of single circuit with branches extending 93 and 60 miles. Installed power for this condition 165,000 kw.

TABLE 1—PRACTICES REGARDING STABILITY FEATURES—Cont'd

	Union Electric Light & Power Co.		The Milwaukee Electric Railway & Light Company		Niagara-Hudson Power Corporation			New England Power Service Company	Hydro-Electric Power Comm. of Ontario	The Shawinigan Water & Power Co.
	Item I Osage- Cahokia	Item II Osage- Page	Item I Lakeside- Granville	Item II Port Washing- ton- Granville	Item I Pleasant Valley- Dunwoodie	Item II Inghams- Rotterdam	Item III Buffalo- Lockport	Item I Comerford- Tewksbury	Item I Ottawa River- Toronto	Item I Ile Maligne- Quebec
A. Transmission										
1. Voltage, kilovolts.....	132	132	132	132	132	110	110	230	220	187
2. Distance, miles.....	177.9	135.5	25	23	62.5	47	21	126	200	136
3. Frequency, cycles.....	60	60	60	60	60	60	60	60	25	60
4. Power, kilowatt sent out.....	90 000	45 000	160 000	130 000	120 000	156 000	200 000	160 000
B. Circuit arrangement										
1. Number of circuits.....	2	1	1	1	2	2	2	2	3	2
2. Intermediate switching stations.....	2	None	1	None	1	None	None	1	None	None
3. Load taken off at inter- mediate points, kilo- watts.....	20 000	None	None	None	20 000	None	None	None	None	None
4. Synchronous condenser, kva at intermediate points.....	50 000	None	None	None	None	None	None	None	None	30 000
5. Bussing arrangements a. Sending end..... b. Receiving end.....	None L.T.	None L.T.	L.T. H.T.	L.T. H.T.	H.T. H.T.	H.T. H.T.	H.T. L.T.	H.T. H.T.	H.T. H.T.	L.T. H.T.
6. Grounding a. Sending end..... b. Receiving end.....	Solid Solid	Solid Solid	Solid None	Solid None	Solid Solid	Solid Solid	Solid Solid	30-ohm resistor 30-ohm reactor	Solid Solid	Solid Solid
C. Generator										
1. Kilovolt-amperes.....	4 units, each 23 888	2 units, each 23 888	375 000	94 000	On P. V. 1 388 000 On Dun. 1 900 000	On Ingh. 979 000 On Rott. 2 300 000	On Bfo. 225 000 On Lock. 3 060 000	4 units, each 39 000	Each 23 500 to 28 500	11 units, each 30 000
2. Short-circuit ratio (or synchronous reac- tance percent).....	1.15	1.15	0.87 & 1.24	0.92	81	1.25	90
3. Transient reactance x_d' percent.....	30	30	15	15.5	15.4 9.8	16.1 12.2	12.7 45.8	31	28	41
4. Inertia constant H	3.56	3.56	2.85 6.58	2.9 6.2	4.5 5.05	2.73	3.1	3.03
5. Damper winding.....	None	None	Inner; copper; outer, Ever- dur	None	None
D. Excitation system										
1. Exciter response, per unit —self- or pilot exciter.	1.5 Pilot	1.5 Pilot	Hand reg- ulation	Hand reg- ulation	1.6 Pilot	1.8 Pilot
E. Breakers and relays										
1. Breaker speed, cycles...	7	8	12	8	8	8	8	8	3.5-4	10-12
2. Relaying type.....	Distance	Distance	Induction type	Induction type	Simultan- eous with carrier current	Overcurrent with in- stantan- eous & differential	Differential current & distance	Sequential with bal- anced cur- rent & dis- tance	(Some—8-10) Sequential with imped- ance dis- tance	Parallel line protection with a direc- tional impedance standby 12 up
3. Total time, cycles*.....	8-10	9	93	39	12	10	12	9-11	5-5½ (Some—20)
F. Lightning protection										
1. Tower construction....	120 mi. steel with wood arms 58 mi. steel	Wood pole H frame	Steel	Steel	Steel	Steel	Steel	Steel	Steel	Steel
2. Ground wires.....	147 mi.—2; 31 mi.—1	2	1	1	2	2	2	2	2	2
3. Counterpoises.....	None	None	None	None	None	None	None	None	None	Part contin- uous type & part 250' on each side of tower
4. Insulators.....	147 mi.: 11-5¼" units 31 mi.: 10-4¼" units	11-5¼" units	Susp: 10-4¼" units Deadend: 12-same	(Same as item 1)	Susp: 12 units Deadend: 13 units	Susp: 8 units Deadend: 9 units	Susp: 7 units Deadend: 9 units	Susp: 15-5¼" units Deadend: 17-same	Susp: 18-5" units Deadend: 18-same	Susp: 10 units Deadend: 12 units
5. Lightning arresters....	Yes	Yes	Yes	Yes	Yes	Yes	Yes	Yes	Receiving end	No

*Note: In certain cases of sequential tripping, time given applies to first breaker only.

TABLE 1—PRACTICES REGARDING STABILITY FEATURES—Cont'd

	Super Power Co. Ill. Ill. North. Utilit. Co. & Public Service of Northern Ill.	Super Power Co. of Illinois & Public Service Co. of Northern Illinois		Public Service Co. of Northern Illinois		Northern Indiana Public Service Co.			Public Service Company of Indiana	
	Item I Powerton-Waukegan	Item II Powerton-Waukegan	Item III Powerton-State Line	Item I Waukegan Northwest	Item II Waukegan Northwest	Item I Michigan City-State Line	Item II Michigan City-South Bend	Item III Mich. City S. Bend Monticello	Item I Dresser-Lenore	Item II Columbia-Lenore
A. Transmission										
1. Voltage, kilovolts.....	132	132	132	132	132	132	132	132	132	132
2. Distance miles.....	218.6	243.4	202.4	36.88	36.88	50.6	40.5	101.0	74.8	91.68
3. Frequency, cycles.....	60	60	60	60	60	60	60	60	60	60
4. Power, kilowatts sent out	55 000	55 000	60 000	80 000	80 000	80 000	55 000	25 000	40 000	10 000
B. Circuit arrangement										
1. Number of circuits....	1	1	53 mi: 2 149.4 mi: 1	1	1	1	1	1	2	1
2. Intermediate switching stations.....	2	4	4	None	None	1	None	1	None	1
3. Load taken off at intermediate points, kilowatts.....	30 000	50 000	35 000	None	None	45 000	None	8 000	None	None
4. Synchronous condenser, kva at intermediate points.....	None	20 000	15 000	None	None	None	None	None	None	None
5. Bussing arrangements										
a. Sending end.....	None	None	None	H.T.	H.T.	H.T.	H.T.	H.T.	L.T.	L.T.
b. Receiving end.....	H.T.	H.T.	L.T.	L.T.	L.T.	L.T.	H.T.	L.T.	L.T.	L.T.
6. Grounding										
a. Sending end.....	Solid	Solid	Solid	Solid	Solid	Solid	Solid	Solid	Solid	Solid
b. Receiving end.....	Solid	Solid	Solid	Solid	Solid	Solid	Solid	Solid	Solid	Solid
C. Generator										
1. Kilovolt-amperes.....	61 765	61 765	116 666	2 units, total 129 525	121 000	70 600	70 600	70 600	3 units, each 25 000	2 units, each 78 610
2. Short-circuit ratio (or synchronous reactance, percent).....	120	120	107	1 unit, 152; 1 unit, 154	161	111	111	111	122
3. Transient reactance x_d' percent.....	23	23	20	1 unit, 16.3; 1 unit, 18.6	18.4	23.9	23.9	23.9	13
4. Inertia constant H	5.75	5.75	5.5	1 unit, 4.95 1 unit, 4.14	4.64	4.09	4.09	4.09	3.74
5. Damper winding.....	None	None	None	None	None	None	None	None	None	None
D. Excitation system										
1. Exciter response, per unit—self- or pilot exciter.	0.3 Self	0.3 Self	1.0 Pilot	0.5 Self	1.5 Pilot	0.384 Self	0.384 Self	0.384 Self	Unknown Self	Self
E. Breakers and relays										
1. Breaker speed, cycles....	8-20	8-20	8-20	8	8	12-25	8-12	8-12	6-7	7-13
2. Relaying type.....	Distance	Distance	Distance	Distance & over-current	Distance & over-current	Distance	Distance & over-current	Distance & over-current	Overcurrent	Overcurrent
3. Total time, cycles*....	10-56	10-74	10-74	10-60	10-60	13-67	10-14	12-45	Line: 9-67; G'nd: 9-25	Line: 39-67; G'nd: 12-53
F. Lightning protection										
1. Tower construction....	166 mi.: steel 52 mi.: wood	Steel	Steel	Steel	Steel	Steel	Steel	Steel	Steel	Steel
2. Ground wires.....	185 mi.: 2; 34 mi.: 1	187 mi.: 2; 57 mi.: 1	173 mi.: 2; 30 mi.: 1	2	2	1	1	1	1	1
3. Counterpoises.....	None	None	None	None	None	None	None	None	None	None
4. Insulators.....	103.5 mi.: 12-OB25 620 72.9 mi.: 10-5 1/4" units 42.2 mi.: 8-JD2501	53 mi.: 12-OB25 620 67.4 mi.: 13-OB25 622 123 mi.: 8-JD2501	53 mi.: 12-OB25 620 67.4 mi.: 13-OB25 622 82 mi.: 8-JD2501	8-JD2501	8-JD2501	8-6 1/2" units	8-6 1/2" units	8-6 1/2" units	Susp: 9-10" x4 1/4" units Deadend: 11 same	(Same as item 1)
5. Lightning arresters....	3 stations—yes 1 station—no	3 stations—yes 3 stations—no	4 stations—yes 2 stations—no	None	None	Yes	Yes	Yes	Yes	Yes

*Note: In certain cases of sequential tripping, time given applies to first breaker only.

TABLE 1—PRACTICES REGARDING STABILITY FEATURES—Cont'd

	Detroit Edison Co.	Consumers Power Company**								Tennessee Valley Authority
	Item I Marysville Northeast	Item I Saginaw-Flint	Item II Muskegon-Grand Rapids	Item III Croton-Grand Rapids	Item IV Jackson-Superior	Item V Flint-Delbi	Item VI Kalamazoo-Battle Creek	Item VII Delhi-Jackson	Item VIII Toronto-Akron***	Item I Wilson-Norris
A. Transmission										
1. Voltage, kilovolts.....	120	140	140	140	132	140	140	140	132	154
2. Distance, miles.....	55.5	43.3	36.2	47.1	28.8	19.4	14.3	26.5	64.0	233.4
3. Frequency, cycles.....	60	60	60	60	60	60	60	60	60	60
4. Power kilowatts sent out	40 000	100 000	50 000	67 800	77 500	25 000	25 000	65 000	80 000	50 000
B. Circuit arrangement										
1. Number of circuits....	2	2	1	1	1	1	1	1	1	1
2. Intermediate switching stations.....	None	None	None	None	None	None	None	None	None	None
3. Load taken off at intermediate points, kilowatts.....	None	None	None	None	None	None	None	None	None	None
4. Synchronous condenser, kva at intermediate points.....	None	None	None	None	None	None	None	None	None	None
5. Bussing arrangements										
a. Sending end.....	H.T.	H.T.	H.T.	H.T.	Through transformer	H.T.	H.T.	H.T.	H.T.	H.T.
b. Receiving end....	H.T.	H.T.	H.T.	H.T.	Through transformer	H.T.	H.T.	H.T.	L.T.	L.T.
6. Grounding										
a. Sending end.....	Solid	Isolated** neutral	Isolated** neutral	Isolated** neutral	Isolated** neutral	Isolated** neutral	Isolated** neutral	Isolated** neutral	Solid	2 reactors (each 35 ohms)
b. Receiving end....	Ungrounded	Isolated neutral	Isolated neutral	Isolated neutral	Solid	Isolated neutral	Isolated neutral	Isolated neutral	Solid	Solid
C. Generator										
1. Kilovolt-amperes.....	6 units, total 196 000	140 000	50 000	50 000			50 000		140 000	2 units, each 56 000 (at Norris)
2. Short-circuit ratio (or synchronous reactance, percent).....	1.02	1.0	1.0	1.0			1.0		1.0	1.045
3. Transient reactance X_d' percent.....	23.4	10-12	10-12	10-20					10-12	40.7
4. Inertia constant H	6.6									
5. Damper winding.....	None									Copper
D. Excitation system										
1. Exciter response, per unit—self- or pilot exciter..	Hand regulation	2.0 Pilot	Pilot	Pilot			Pilot		Pilot	1.0 Pilot
E. Breakers and relays										
1. Breaker speed, cycles...	6	8-20	8-20	8	8-20	8-20	8-20	8-20	8-20	8
2. Relaying type.....	Differential	Impedance	Step distance	Step distance	Impedance	Impedance	Impedance	Impedance	High-speed step distance	Simultaneous with carrier, or sequential with distance
3. Total time, cycles*....	8	20-32	10-22	10	20-32	20-32	20-32	20-32	10-22	
F. Lightning protection										
1. Tower construction....	Steel	Steel	Steel	Steel	Steel	Steel	Steel	Steel	Steel	Steel except Tenn. R. to Monteagle (wood)
2. Ground wires.....	1	1	2	1	1	1	1	1	1	2
3. Counterpoises.....	None	None	None	None	None	None	None	None	None	None
4. Insulators.....	Susp: 9-5" units Deadend: 10-same	Susp: 9-4 3/4" units Deadend: 9-5 3/4" units 12-4 3/4" units Deadend 11-5 3/4" units	Susp: 10-5 3/4" units Deadend: 11-same	(Same as item II)	Susp: 10-5" units Deadend: 12-same	Susp: 10-5 3/4" units Deadend: 11-same	Susp: 9-4 3/4" units Deadend: 12-same	Susp: 10-4 3/4" units Deadend: 12-same	Susp: 10-5 3/4" units Deadend: 11-same	17.5 miles; Susp: 19-5 1/2" units Deadend: 21 same 96 miles; Susp: 9-6 1/2" units Deadend: 11 same 120 miles; Susp: 16-16 1/2" units or 19-5 1/2" units Deadends: 21-5 1/8" units Yes
5. Lightning arresters....	Yes	Yes	Yes	Yes	Yes	Yes	Yes	Yes	Yes	Yes

*Note: In certain cases of sequential tripping, time given applies to first breaker only.

**Editor's note: The Consumers Power Company in 1940 changed their 140 kv system from isolated neutral to solidly grounded system. All information in this table holds only up to that time.

***Editor's note: Item VIII Toronto-Akron is part of the Ohio Edison Co. system.

TABLE 1—PRACTICES REGARDING STABILITY FEATURES—Cont'd

	Pennsylvania Water and Power Co.		Philadelphia Electric Co.		Pennsylvania and New Jersey Interconnection		
	Item I Safe Harbor-Washington	Item II Safe Harbor-Perryville	Item I Conowingo-Plymouth Mtg.	Item II Plymouth Mtg.-Westmoreland	Pennsylvania Power & Light Company Philadelphia Electric Company Public Service Electric and Gas Company		
					Item I Plymouth Mtg.-Seigfried	Item II Plymouth Mtg.-Roseland	Item III Seigfried-Roseland
A. Transmission							
1. Voltage, kilovolts.....	230	132	220	66	220	220	220
2. Distance, miles.....	92	30	57.6	10	48.7	75.8	83.7
3. Frequency, cycles.....	60	25—1 phase	60	60	60	60	60
4. Power, kilowattseentout	168 000	49 400	252 000	212 000	185 000†	185 000†	185 000†
B. Circuit arrangement							
1. Number of circuits.....	1	4	2	3	1	1	1
2. Intermediate switching stations.....	None	None	None	None	None	None	None
3. Load taken off at intermediate points, kilowatts.....	None	None	None	None	None	None	None
4. Synchronous condenser, kva at intermediate points.....	None	None	None	None	None	None	None
5. Bussing arrangements							
a. Sending end.....	None	None	H.T.	H.T.	H.T.	H.T.	H.T.
b. Receiving end.....	None	None	H.T.	H.T.	H.T.	H.T.	H.T.
6. Grounding							
a. Sending end.....	Solid	Midpoint of transfs. grounded through 330-ohm resistance	Solid	Solid	Solid	Solid	Solid
b. Receiving end.....	Solid		Solid	Solid	Solid	Solid	Solid
C. Generator							
1. Kilovolt-amperes.....	5 units, total 155 500	35 000—Gen. 31 250—Freq. chgr.	7 units, total 280 000	Intersystem tie	Intersystem tie	Intersystem tie
2. Short-circuit ratio (or synchronous reactance percent).....
3. Transient reactance x_2 percent.....	26.7-29.0	27.5	26-28
4. Inertia constant H	3.31	4.3	2.84-3.69
5. Damper winding.....	Copper	Copper	None
D. Excitation system							
1. Exciter response, per unit—self- or pilot exciter.	225 volts/sec	200 volts/sec	3.2-3.5
E. Breakers and relays							
1. Breaker speed, cycles...	8	3.5	8-12	8	8-12	3.5-8	3.5-10
2. Relaying type.....	Distance	Voltage balance	Phase: Hi-speed diff., Induction impedance G'nd: hi-speed diff. & hi-speed overcurrent	Phase: Induction impedance G'nd: hi-speed directional overcurrent	Phase: Directional impedance Ground: Hi-speed directional overcurrent	(Same as Item I)	(Same as Item I)
3. Total time cycles*.....	9-10	8.5	Phase: 9-18 G'nd: 9-18	Phase: 20-60-150 G'nd: 9-18-60	Phase: 9-75 Gr'd: 9-35 or 70-90	Phase: 9-75 Gr'd: 9-35 or 50-100	Phase: 12-60 Gr'd: 12-30 or 60-100
F. Lightning protection							
1. Tower construction....	Steel	Steel	Steel	Steel	Steel	Steel	Steel
2. Ground wires.....	2	2	2	2	2	2	2
3. Counterpoises.....	Crowfoot system	Crowfoot system	None	Continuous type, 3.7 mile section	None	None except grdg. cable at high-res. tower footings	(Same as Item II)
4. Insulators.....	20-5¼" units	12-5¼" units	Susp: 16-5¼" units Deadend: 18-same	Susp: 8-5¼" units Deadend: 9-same	Susp: 16-5¼" units Deadend: 18-same	Susp: 16 or 18-5¼" units Deadend: 18 or 20-same	Susp: 14, 16, or 18-5¼" units Deadend: 18 or 20-same
5. Lightning arresters....	Yes	None	Yes	Yes	Plymouth Mtg. only	Plymouth Mtg. only	None

*Note: In certain cases of sequential tripping, time given applies to first breaker only.
 †Based on thermal conditions. ‡High-speed directional impedance phase relays installed at Plymouth Meeting end of Items I and II.

TABLE 2—STATISTICS OF UTILITIES WITH SALES EXCEEDING TWO-BILLION KWH

PRIVATELY OWNED ELECTRIC UTILITIES(a)

Line No.	Company	Sales Million Kw Hr	Generation Million Kw Hr	Installed Capacity in Kw		
				Steam	Hydraulic	Total(c)
1	Consolidated Edison Company of New York, Inc.....	10 176	11 177	2 567 700(e)		2 567 700
2	Commonwealth Edison Company.....	9 582	8 793	1 590 000		1 590 000
3	Pacific Gas and Electric Company.....	9 047	8 660	667 629	969 233	1 637 748
4	Philadelphia Electric Company.....	7 369	6 268	1 255 250		1 255 250
5	Southern California Edison Company.....	6 164	6 799	521 500	441 020(e)	962 520
6	The Detroit Edison Company and Subsidiaries.....	6 136	6 876	1 300 000	8 300(e)	1 308 300
7	The Ohio Power Company.....	5 065	5 127	799 000	4 000	803 000
8	Public Service Electric and Gas Company.....	4 989	5 871	1 411 150		1 411 150
9	Duke Power Company.....	4 785	5 225	660 150	497 273(e)	1 157 498
10	Appalachian Electric Power Company, Inc.(f).....	4 399	4 362	601 890	121 517	724 257
11	Alabama Power Company.....	4 351	4 302	285 000(g)	414 500(h)	699 560
12	Union Electric Power Company.....	4 228	4 176	602 500	116 000	718 500
13	The Niagara Falls Power Company.....	4 194	3 485		374 800(e)	374 800
14	The Cleveland Electric Illuminating Company.....	4 123	4 421	690 000		690 000
15	Buffalo Niagara Electric Corporation.....	3 979	3 589	625 000	46 787	671 787
16	Duquesne Light Company.....	3 779	3 953	624 000		624 000
17	Georgia Power Company.....	3 770	3 509	444 000	286 300(i)	730 914
18	Consumers Power Company.....	3 633	3 932	602 000	148 015	750 015
19	West Penn Power Company.....	3 303	3 469	588 500	50 215(j)	638 715
20	Public Service Company of Northern Illinois.....	3 252	1 801	365 000	600	365 600
21	Consolidated Gas, Electric Light and Power Company of Baltimore.....	3 166	2 565	519 500		519 500
22	Pennsylvania Power and Light Company.....	2 974	2 589	406 462	44 373	451 035
23	Boston Edison Company.....	2 804	2 879	557 610	250(e)	557 860
24	Union Electric Company of Missouri.....	2 796	859	118 500(e)	129 000	247 500
25	Wisconsin Electric Power Company.....	2 780	3 029	674 500		674 500
26	Virginia Electric and Power Company.....	2 427	2 629	447 500	37 141(e)	484 841
27	Northern States Power Company.....	2 412	2 556	452 920	16 040(e)	490 225
28	Chicago District Electric Generating Corp.....	2 362	2 362	358 000		358 000
29	The Montana Power Company.....	2 300(k)	2 485		317 540	317 540
30	Beech Bottom Power Company, Inc.(l).....	2 280(l)	2 280(l)	300 000(l)		300 000(l)
31	Puget Sound Power and Light Company.....	2 250	1 629	93 000	194 750(e)	287 750
32	New England Power Company(m).....	2 249	378	17 500	132 420	149 920
33	The Washington Water Power Company.....	2 146	1 374		203 210	203 210
34	The Cincinnati Gas and Electric Company.....	2 130	2 253	470 000		470 000
35	Indiana and Michigan Electric Company(t).....	2 102	1 575	300 000	22 004	322 004
36	Central New York Power Corporation(n).....	2 046	2 549	270 000	220 102(o)	490 102
37	Ohio Edison Company.....	2 043	2 118	427 000	1 950	428 950
38	Potomac Electric Power Company.....	2 007	2 369	505 000		505 000

TABLE 2—STATISTICS OF UTILITIES WITH SALES EXCEEDING TWO-BILLION KWH—Cont.

PUBLICLY OWNED ELECTRIC UTILITIES(b)

Line No.	Company	Sales(d) Million Kw Hr	Generation Million Kw Hr	Installed Capacity in Kw		
				Steam	Hydraulic	Total(c)
1	Tennessee Valley Authority(p).....	12 245	14 248	425 850	1 809 582	2 236 282
2	Bonneville Power Administration(q).....	10 272				
3	U.S. Bureau of Reclamation Columbia Basin Project (Grand Coulee Dam)(p).....	6 894	6 940		992 000	992 000
4	U.S. Bureau of Reclamation Boulder Canyon Project(r)...	5 285	5 334		1 034 800	1 034 800
5	U.S. Corps of Engineers—Bonneville Dam Project(p).....	3 992	3 998		518 400	518 400
6	Los Angeles Department of Water and Power(p).....	3 435	1 192	257 500(s)	126 025	383 525

- a Data taken from *Statistics of Electric Utilities in the United States—1948*, published by the Federal Power Commission.
- b Data taken from *Statistics of Publicly Owned Electric Utilities—1948*, published by the Federal Power Commission.
- c Total includes internal combustion engine capacity.
- d Sum of sales to ultimate customers and sales for resale.
- e Excludes some capacity owned by others and operated by respondent or capacity leased from others. See Federal Power Commission publication(a) for exact amount.
- f Report reflects acquisition of Holston River Power Company; acquired June 30, 1948.
- g Excludes 40 000 kw leased from others and 10 340 kw owned and operated by others for the account of respondent.
- h Excludes 8000 kw owned by others and operated as a joint facility.
- i Includes 2000 kw leased to others; excludes 2800 kw leased from others.
- j Includes 50 000 kw leased to others.
- k Excludes 56 882 thousand kwh billed but not delivered.
- l Company has no utility plant but operates the Windsor steam electric generating station for the account of its two owners, West Penn Power Company and Ohio Power Company. The output of the station is also included in the energy accounts of the owner-companies.
- m Report reflects acquisition of properties of the Bellow Falls Hydro-Electric Corporation on July 28, 1948 but not the acquisition of Eastern Massachusetts Electric Company acquired at the close of business on December 31, 1948.
- n Report reflects acquisition of Northern Development Corporation; acquired July 31, 1948.
- o Includes 8000 kw jointly owned; excludes 7040 kw leased from others.
- p Report for year ended June 30, 1948.
- q Marketing agent for power generated at Bonneville Dam Project and Columbia Basin Project (Grand Coulee Dam). Report for year ended June 30, 1948.
- r Report for year ended May 31, 1948.
- s Excludes 50 000 kw leased from others.
- t Report reflects acquisition of Indiana Service Corp.; acquired August 31, 1948.

TABLE 3—LIGHTNING PERFORMANCE AND CONSTRUCTION OF 110 KV TO 165 KV LINES*

Company	Line	KV	Line Construction														Lightning Protection										
			Circuits	Miles (R.W.)	Steel—Wood	Struct. (Fig. No.)	Conductor Height at Tower Min.—(Ft.)			Gr. W. Height (Ft.) Above Top Cond.	Insulators			Clearance-Line To Structure (In.)	Conductor Alum.—Cop.	Armor Rods	Vibration Dampers	Avg. Span (Ft.)	Ground Wires	Counter-Poles		Grounds Rod		Gr. Res. of Structures			
							Number		D. E.		Spacing (Inches)	Susp.	D. E.							Fig. No.	% of Line	Per Tower	% of Line	Avg.			Max.
							Top	Mid.																Bot.	Before Op.-Gr.	After Op.-Gr.	
1	A	132	1	82.5	W	1(i)	52	52	52	11.8	5 3/4	10	12	62/50	A	Yes	Yes	1000	2	1(p)	68	1	7.9	18	27		
2	AA	110	1	38.8	W	1(j)	30	30	30	5.1	5 1/2	6	7	36/45	A	No	Yes	632	0	No	0	1	100	91	81.7	260	
3	B	120	1	37.6	W	1(j)	30	30	30	5.7	5 1/2	8	9	42/45	A	Yes	No	645	1	No	0	0	0	0	0	0	
4	C	110	1	55.3	W	1(j)	60	50	40	5.7	5 1/2	7	8	38/45	A	Yes	No	491	0	No	0	0	0	0	0	0	0
5	D	110	2	52.9	W	1(b)	60	60	60	9	5 1/2	8	9	O	No	No	881	2	No	0	0	0	0	0	0	
6	A	154	2	28.7	W	1(a,l)	36	36	36	12.6	5 1/2	10	12	55/-	O	Yes	No	977	1	No	0	0	0	0	0	0	
7	A	115	2	16.5	W	1(l)	46	46	46	8	5 1/2	9	9	36/45	O	No	Yes	600	2	No	0	0	0	0	0	0	
8	B	115	2	30.6	W	1(l)	46	46	46	8	5 1/2	9	9	36/45	O	No	Yes	600	2	No	0	0	0	0	0	0	
9	C	115	2	13.2	W	1(l)	46	46	46	8	5 1/2	9	9	36/45	O	No	Yes	600	2	No	0	0	0	0	0	0	
10	D	115	2	20.7	W	1(l)	46	46	46	8	5 1/2	9	9	36/45	O	Yes	Yes	600	2	No	0	0	0	0	0	0	
11	E	115	1	19.5	W	1(l)	46	46	46	8	5 1/2	9	9	36/45	O	No	Yes	600	2	No	0	0	0	0	0	0	
12	F	115	1	17.8	W	1(l)	46	46	46	8	5 1/2	9	9	36/45	O	No	Yes	600	2	No	0	0	0	0	0	0	
13	A	132	2	11.9	W	1(b)	100	87	74	13	5 1/2	9	11	42/45	A	No	No	790	2	No	0	0	0	0	0	0	
14	B	132	2	10.9	W	1(b)	100	87	74	13	5 1/2	9	11	42/45	A	No	No	814	2	No	0	0	0	0	0	0	
15	C	132	2	4.5	W	1(b)	100	87	74	13	5 1/2	9	11	42/45	A	No	No	795	2	No	0	0	0	0	0	0	
16	D	132	2	23.4	W	1(b)	100	87	74	13	5 1/2	9	11	42/45	A	No	No	840	2	No	0	0	0	0	0	0	
17	E	132	2	28.8	W	1(b)	97	84	71	13	5 1/2	9	11	42/45	A	No	Yes	512	2	No	0	0	0	0	0	0	
18	A	110	1	23.6	W	1(b)	70	60	50	8.5	5 1/2	6	8	60/30	O	No	No	560	2	No	0	0	0	0	0	0	
19	A	132	1	79.9	W	1(a)	69	57	45	10	5	10	11	48/45	A	Yes	Yes	880	1	No	0	0	0	0	0	0	
20	B	132	1	54.0	W	1(a)	76	64	52	10.7	5	10	11	48/45	A	Yes	Yes	970	1	No	0	0	0	0	0	0	
21	C	132	1	26.4	W	1(d)	69	57	45	10	5	10	11	48/45	A	Yes	Yes	880	1	No	0	0	0	0	0	0	
22	D	132	1	8.2	W	1(a)	76	64	52	10.3	5	10	11	48/45	A	Yes	Yes	970	1	No	0	0	0	0	0	0	
23	DD	132	1	23.9	W	1(a)	75	63	51	10.3	5	10	11	51/45	C	No	No	770	1	No	0	0	0	0	0	0	
24	A	132	1	14.8	W	1(a)	76	64	52	9.3	6 1/2	9	11	45/45	C	No	No	701	1	No	0	0	0	0	0	0	
25	A	132	1	30.9	W	1(b)	74	61	48	9	6 1/2	8	8	60/30	C	No	No	500	(a)	No	0	2	100	3	5		
26	B	132	1	27.9	W	1(b)	74	61	48	9	6 1/2	8	8	60/30	C	No	No	500	(a)	No	0	2	100	3	5		
27	C	132	1	30.9	W	1(b)	81	68	55	10.4	6 1/2	8	8	60/30	C	No	No	500	1	No	0	2	43	3	5		
28	D	132	1	42.2	W	1(b)	84	71	58	9	6 1/2	8	8	60/30	C	No	No	880	(a)	1(n)	3	2	45	10	50		
29	E	132	1	61.7	W	1(b)	84	71	58	9	6 1/2	8	8	60/30	C	No	No	880	(a)	1(a)	3	2	43	10	50		
30	F	132	1	24.4	W	1(b)	84	71	58	10.4	6 1/2	8	8	60/30	C	No	No	880	1	No	0	No	0	10		
31	G	132	1	29.7	W	1(b)	84	71	58	9	6 1/2	8	8	60/30	C	No	No	880	1	No	0	No	0	85	10		
32	H	132	2	36.9	W	1(b)	84	71	58	9	6 1/2	8	8	60/30	C	No	No	880	2	No	0	No	0	51	8		
33	I	132	1	10.6	W	1(b)	84	71	58	9	6 1/2	8	8	60/30	C	No	No	880	2	No	0	No	0	56	10		
34	A	110	1	79.4	W	1(j)	43	43	43	5 1/2	8	8	31/45	C	No	No	509	0	No	0	No	0	0	0	0	
35	B	110	1	83.7	W	1(j)	49	49	49	10.5	5 1/2	8	9	A	Yes	No	592	2	No	0	2	100		
36	A	132	1	50.3	W	1(a)	70	58	46	8.5	4 1/2	10	12	47/50	A	No	No	588	1	No	0	0	0	0	0		
37	B	132	1	27.9	W	1(a)	70	58	46	8.5	4 1/2	10	12	37/50	A	No	No	608	1	No	0	0	0	0	0		
38	C	132	1	22.4	W	1(a)	70	58	46	8.5	4 1/2	10	12	47/50	A	No	No	612	1	No	0	0	0	0	0		
39	D	132	1	29.4	W	1(a,b,e)	70	58	46	8.5	4 1/2	10	12	47/50	A-C	No	No	588	1-2	No	0	4	?	1.96	4.8		
40	E	132	1	22.8	W	1(a,b)	72	59	47	9.5	5 1/2	9/11	12/14	37/50	C	No	No	602	1-2	No	0	4	?	3.5	14.1		
41	F	132	1	7.9	W	1(a)	72	59	47	9.5	4 1/2	10	12	37/50	C	No	No	591	1	No	0	No	0	?		
42	G	132	1	52.3	W	1(a,b,e)	70	58	46	8.5	4 1/2	10/12	12/14	37/50	A-C	No	No	590	1-2	No	0	4	?	2.2	14.1		
43	H	132	1	76.1	W	1(a)	70	58	46	8.5	4 1/2	10	12	37/50	A	No	No	603	1	No	0	2-3	(d)		
44	A	132	1	5.8	W	1(a)	76	63	50	11	5	10	12	48/38	O	No	No	644	1	No	0	2-3	(d)		
45	B	132	2	18.0	W	1(a)	76	63	50	11	5	10	12	48/38	C	No	No	680	1	No	0	2-3	(d)		
46	C	132	2	18.0	W	1(a)	76	63	50	11	5	10	12	48/38	C	No	No	680	1	No	0	2-3	(d)		
47	D	132	2	8.9	W	1(a)	76	63	50	11	5	10	12	48/38	C	No	No	715	1	No	0	2-3	(d)		
48	E	132	1	8.9	W	1(a)	76	63	50	11	5	10	12	48/38	C	No	No	715	1	No	0	2-3	(d)		
49	F	132	2	9.9	W	1(a)	76	63	50	11	5	10	12	48/38	C	No	No	710	1	No	0	2-3	(d)		
50	G	132	2	9.9	W	1(a)	76	63	50	11	5	10	12	48/38	C	No	No	710	1	No	0	2-3	(d)		
51	H	132	2	6.4	W	1(a)	76	63	50	11	5	10	12	48/38	C	No	No	650	1	No	0	2-3	(d)		
52	I	132	1	6.1	W	1(a)	76	63	50	11	5	10	12	48/38	C	No	No	675	1	No	0	2-3	(d)		
53	J	132	2	5.1	W	1(a)	76	63	50	11	5	10	12	48/38	C	No	No	715	1	No	0	2-3	(d)		
54	K	132	2	6.5	W	1(a)	76	63	50	11	5	10	12	48/38	C	No	No	680	1	No	0	2-3	(d)		
55	L	132	2	53.2	W	1(a)	76	63	50	11	5	10	12	48/38	C	No	No	695	1	No	0	2-3	(d)		
56	M	132	2	8.1	W	1(a)	76	63	50	11	5	10	12	48/38	C	No	No	700	1	No							

TABLE 3—LIGHTNING PERFORMANCE AND CONSTRUCTION OF 110 KV TO 165 KV LINES—Cont'd

Grading & Arc Devices	Fault Clearing Time (Cycles)		Line Operation												Avg. Out-ages/100 Mile of Line/Year	Cases of		Lightning Territory?	Isokeraunic Level	Operating Record Satisfactory	Considering Improvements To Better Line Performance	Company	Line
	Primary (Min.)	Back Up (Min.)	OCB (Min.)	Years in Service	Outages Due to Lightning One Circuit / Two Circuit											Burned Down Conductors	Prolonged Outages						
					1928	1929	1930	1931	1932	1933	1934	1935	1936	1937									
28	29	30	31	32	33	34	35	36	37	38	39	40	41	42	43	44	45	46	47	48	49	1	2
RR	Inst.	15	7
RR
T
P-T
P
RR-Pc	12	66	8	5
HH ¹	4	1	10	10	0/9	0/5	0/14	0/6	0/6	0/8	0/10	0/11	0/15	0/8	0/35.5	0	1	S	50	No	Yes-T	2	3
RR	1	25	8	12	3/0	4/5	0/1	3/0	3/0	3/0	3/0	4/0	6/0	5/1	25/7.3	0	0	M	22	Yes	No	4	4
RR	1	16	8	11	4/0	8/0	5/0	1/0	3/0	5/0	2/0	4/0	5/0	6/0	14/0	0	0	M	22	Yes	No	4	4
RR	1	35	8	9	0/0	0/0	2/0	0/0	0/0	0/0	0/0	0/0	1/0	1/0	3.8/0	0	0	M	22	Yes	No	4	4
RR	1	16	17	9	0/0	7/1	0/0	0/0	6/0	1/0	1/0	7/0	4/0	14/0.5	0	0	M	22	Yes	No	4	4
RR	3	20	17	7
RR	1	5	1	1
RR	4	120	6	10	0/0	0/0	0/0	0/0	1/0	0/0	0/0	0/0	0/0	0/0	1.8/0	0	0	M	28	Yes	No	6	6
RR	6	180	12	9	0/0	2/0	1/0	0/0	0/0	0/1	0/0	0/0	1/0	1/0	3.6/1.8	0	0	M	28	Yes	No	6	6
RR	6	168	12	9	0/0	2/0	0/0	0/0	0/0	0/0	0/0	0/0	0/0	0/0	4.4/2.2	0	0	M	28	Yes	No	6	6
RR	6	174	6	9	0/0	0/0	0/0	0/1	0/0	0/0	0/0	0/0	0/1	0/0	0/1	0	0	M	28	Yes	No	6	6
RR	12	150	12	9	0/0	0/1	1/1	1/0	0/0	1/1	3/2	3/1	2/2	2/2	5.4/3.5	0	0	M	28	No	Yes-Cp.	6	6
No	18	120	18	26	0	0	1	2	0	4	3	2	4	1	7.2 ^o	0	0	S	35	Yes	Yes-Cp. & Gr. Rds	9	9
LH	3	42	13	11	1	3	4	6	5	1	1	5	3	2	3.9	0	0	H	40	Yes	Yes-Reduce Gr. Res.	13	13
LH	3	15	13	9	0	3	0	0	1	2	2	3	2	3	3.9	0	0	M	40	Yes	Yes-Reduce Gr. Res.	13	13
LH	3	29	13	12	1	0	0	0	1	0	2	1	1	2	3.0	0	0	M	40	Yes	Yes-Reduce Gr. Res.	13	13
LH	3	29	8	11
LH	3	29	8	11
No	1	60	8	10
LR	5	No	16	14	2	1	0	1	0	2	0	0	0	0	1.9	0	0	S	42	Yes	No	15	15
No	5	No	16	11	0	0	1	0	0	0	0	0	0	0	0.35	0	0	S	42	Yes	No	15	15
No	2	No	16	7
No	2	No	16	11
No	5	No	16	9
RR ^b	5	No	11	8
No	1	No	16	13	0	1	1	0	0	0	1	1	0	0	7.3	0	0	S	42	Yes	No	15	15
No	1	No	16	10	0	1	1	0	0	0	0	1	0	0	1.0	0	0	H	42	Yes	No	15	15
No	1	No	16	13	0/0	0/0	0/1	0/0	0/0	1/0	1/0	1/0	1/0	1/0	1.5/0.3	0	0	H	42	Yes	No	15	15
HH	12	No	16	9	0	0	0	0	0	0	0	0	0	0	0.9	0	0	H	42	Yes	No	15	15
.....	7	42	12	7
LH	60	No	12	14	6	7	7	7	7	3	3	2	4	2	5.5	0	0	H	33	No	16	16
LH	60	No	12	12	1	2	2	0	0	0	0	1	3	7	9.5	0	0	H	35	No	No	17	17
FC	60	No	12	12	2	6	2	1	0	0	1	0	0	0	4.0	0	0	H	35	No	No	17	17
LH-P	81	No	12	13
P-T	31	No	8	2
FC	27	No	12	12	1	2	0	0	0	0	0	0	0	0	2.2	0	0	H	35	Yes	No	17	17
LH-P	60	No	12	2
LH	60	No	12	12
No	12	1	3	0	0	2	1	1	0	0	0	0	13.8	0	0	M	38	Yes	No	18	18
No	12	0/0	3/0	0/0	0/0	0/1	0/0	0/0	0/0	0/0	0/0	0/0	2.8/0.6	0	0	M	38	Yes	No	18	18
No	10	0	1/0	0/0	0/0	0/0	0/0	0/0	0/0	0/0	0/0	0/0	1.7/0	0	1	M	38	Yes	No	18	18
No	11	0/0	0/0	0/0	0/0	0/0	0/1	0/0	0/0	0/0	1/0	0/0	1.1/1.1	0	0	M	38	Yes	No	18	18
No	10	0	1	0	0	1	0	1	0	0	0	0	4.4	0	0	M	38	Yes	No	18	18
No	1
No	12	1/1	1/0	0/0	0/0	0/1	0/0	0/0	0/0	0/0	0/2	1/0	3.0/4.0	0	1	M	38	Yes	No	18	18
No	12	0/0	0/0	0/0	0/0	0/0	0/0	0/0	0/0	1/0	2/0	1/0	6.3/0	0	0	M	38	Yes	No	18	18
No	14	1	1	0	0	3	0	0	0	0	0	0	8.2	0	0	M	38	Yes	No	18	18
No	5
No	5
No	9	0/0	0/0	0/0	1/1	1/0	0/0	1/0	2/1	0/0	1/0	1/0	1.0/0.4	0	0	M	38	Yes	No	18	18
No	7
No	9	0/0	0/0	0/0	0/0	0/0	0/0	2/0	0/0	0/0	0/0	0/0	3.1/0	0	0	M	38	Yes	No	18	18
LH	12	No	26	17	0/0	7/2	3/0	2/0	3/1	0/2	2/0	1/2	3/0	1/0	3.3/1.2	0	0	M	38	No	Yes-Gr. Rds. & Cp.	18	18
LH-FC	12	No	13-8	3/0	4/0	1/0	1/3	0/0	0/0	0/0	0/0	0/0	0/0	1/0	2.3/0.7	0	0	M	35	Yes	Yes-Gr.Rds.&Gr.Wr.	20	20
LH	12	No	18	16	14	17	23	6	10	13	7	6	4	26.2	1	1	M	35	Yes	Yes-Cp.	20	20	
LH	3	No	10	0	3	1	2	0	2	5	0	4	1	4.7	0	0	M	35	Yes	Yes-Cp.	20	20	
LH	3	No	20	1	2	5	4	4	21</														

TABLE 3—LIGHTNING PERFORMANCE AND CONSTRUCTION OF 110 KV TO 165 KV LINES—Cont'd

Grading & Arc Devices ¹	Fault Clearing Time (Cycles)			Line Operation																			Considering Improvements To Better Line Performance	Company	Line
	Relays			Years in Service	Outages Due to Lightning One Circuit / Two Circuit										Cases of			Operating Record Satisfactory							
	Primary (Min.)	Back Up (Min.)	OCB (Min.)		1928	1929	1930	1931	1932	1933	1934	1935	1936	1937	Avg. Out-ages/100 Mile of Line/Year	Burned Down Conductors	Prolonged Outages		Lightning Territory ²	Isokeraunic Level					
																					31	32			
28	29	30	31	32	33	34	35	36	37	38	39	40	41	42	43	44	45	46	47	48	49	1	2		
RR	1	46	8	9	1/0	2/0	0/0	0/1	0/0	2/0	1/0	3/1	3/0	4.6/0.8	0	0	H	45	Yes	No	23	M		
RR	1	29	8	9	5/1	6/3	2/0	3/1	9/1	4/0	4/2	3/0	11/0	6.5/1.1	0	0	H	46	Yes	No-FB Now Inst.	23	N		
RR	1	41	8	10	7	9	1	6	5	11	0	6	13.6	0	9	H	41	No	Yes-Gr.Cp.Inst.1938	23	O		
RH-T ³	1	41	8	13	10/2	9/2	1/3	3/5	2/2	2/4	16/9	14/9	6/0	12/1	10.4/5.0	0	0	S	45	Yes	No	23	P		
RR-RH	1	18	8	13	2	1	0/0	0/1	0/2	1/1	0/4	2/0	5/3	2/0	6.0/6.3	0	0	S	46	Yes	No	23	R		
RR	1	24	8	8	3	3	5	3	9	5/3	7/2	8/2	11/6	7.8/3.3	0	0	H	45	Yes	Yes-Gr.-Cp.-T-FB	23	S		
RR	1	29	8	12	5/7	24/3	11/1	19/4	8/5	10/4	13/3	10/6	11/4	11/7	7.7/2.6	0	0	S	50	Yes	No	23	U		
RR-T ³	1	41	8	11	7.6	12.1	17.5	13.7	4.5	9.7	1	3	7	12	23.4	0	0	S	55	No	Yes-T Revamp	23	V		
RH	1	29	8	12	6/4	11/5	8/3	15/11	4/6	3/2	7/9	6/2	23/20	10/15	21.7/18.0	0	0	S	54	No	Yes-Gr.-Cp.-FB	23	W		
RH	1	41	8	10	5	13	7	9	7	6	13	2	19	4	16.4	0	0	S	56	Yes	No	23	X		
RR	1	24	22	7	4/5	2/2	4/3	2/1	1/1	8/0	2/4	9.4/6.6	0	0	S	51	Yes	No	23	AA		
No	1	18	8	8	11	17	7	19	17	21	20	37.2	0	0	S	54	No	Yes-Gr.-Cp.	23	BB		
RH	1	41	8	10	16/2	11/9	7/1	10/7	8/8	6/7	3/9	6/6	13/7	9/7	18.6/13.2	0	0	S	54	No	No	23	CC		
RH	1	24	8	10	5	16	9	21	16	9	6	16	22	5	32.2	0	0	S	55	No	Yes-Gr.-Cp.-FB	23	DD		
RR	1	41	8	9	4/3	1/2	3/1	1/1	1/3	3/1	5/4	11/8	0	0	S	53	Yes	No	23	EE		
RH	1	41	8	12	12/1	11/4	4/1	5/5	2/0	11/3	8/5	0/2	11/2	1/3	16.0/6.4	0	0	S	54	Yes	No	23	FF		
T	1	29	8	8	2.1	0	0	S	52	Yes	No	23	GG		
RR	1	35	8	8	9.5/6.9	0	0	H	40	Yes	No	23	HH		
RH	1	24	8	9	9.3	0	0	H	42	No	Yes-2-Circ. 1938	23	II		
RH	10	35	8	13	0/0	1/2	1/0	0/0	2/1	0/0	0/0	2/0	0/1	1/0	14.3/8.2	0	0	H	41	Yes	No	23	JJ		
HH	1	29	22	22	2/0	2/0	0/0	0/2	1/0	1/0	0/1	1/0	1/1	0/0	1.5/0.7	0	0	M	45	Yes	No	23	KK		
RR	1	18	22	8	6.8/2.0	0	0	H	45	Yes	No	23	LL		
RR	Inst.	102	8	13	1/1	3/1	0/1	7/0	8/2	1/0	6.4/1.2	0	0	S	55	Yes	No	25	AA		
RR	Inst.	90	8	8	0	0	S	55	Yes	No	25	AA		
No	Inst.	24	8	7	0/0	0/0	1/0	0/0	0/0	0/0	0.12/0	0	0	S	55	Yes	No	25	BB		
No	Inst.	24	8	7	0	0	S	55	Yes	No	25	BB		
HH	18	No	26	7	6/0	2/0	0/0	0	0	1	0	0	0	0	0.21	0	0	S	55	Yes	No	25	CC		
No	12	90	8	3	0	0	H	35	Yes	No	26	AA		
LH	18	51	12	8	0/0	1/1	0/1	2/2	1/0	0/0	1/0	2.1/1.7	0	0	H	45	Yes	No	27	AA	
LH ³	28	Inst.	12	24	0/1	0/0	0/1	0/0	0/0	0/0	1/0	0/0	0/0	1/0	1/1	0.6/0.6	1	1	M	35	Yes	No	29	AA	
LH ³	36	Inst.	14	24	0/0	0/0	1/1	0/1	0/0	1/0	0/0	0/0	0/0	1/1	0.4/0.4	0	0	M	35	Yes	No	29	BB		
No	23	Inst.	13	20	0	0	0	0	0	0	0	0	0	0	0	0	0	M	35	Yes	No	29	CC		
No	34	Inst.	22	20	1	0	0	1	0	0	0	0	1	1	0.5	0	0	M	35	Yes	No	29	DD		
No	30	No	11	0	0	1	0	0	0	0	0	0	3	0	0.5	1	1	M	35	Yes	No	29	EE		
No	41	No	14	14	0	0	0	0	0	0	0	0	0	0	0	0	0	M	35	Yes	No	29	FF		
No	1	8	16	9/0	0/0	0/0	2/0	0/0	11.4/0	0	0	M	30	Yes	No	30	AA		
No	1	8	8	1/0	0/0	1/0	0/0	0/0	1.8/0	0	0	M	30	Yes	No	30	BB		
No	1	8	15	0/0	1/1	0/1	0/0	0/0	0.4/0.7	0	0	M	30	Yes	No	30	CC		
No	1	20	12	7/5	7/1	6/1	0/2	11/3	5.7/2.2	0	0	M	30	No	No	30	DD		
No	1	20	7	8/0	2/1	2/3	1/0	3/1	4.5/1.4	0	0	M	30	Yes	No	30	FF		
No	20	Inst.	7	11	0	0	L	25	Yes	No	31	AA		
No	45	Inst.	3	17	0	0	L	25	Yes	No	31	BB		
No	2	17	5	14	8/0	5/2	1/0	2/0	1/1	2/0	1/0	0/0	0/1	5/3	6.6/1.1	0	2	H	35	Yes	No	32	AA		
LH	2	15	5	10	2	1	3/0	3/0	2/0	7/0	4/0	1/0	2/0	3/1	5.6/0.2	1	1	H	35	Yes	No	32	BB		
LH	2	26	5	11	1/0	1/0	0/0	0/0	0/0	1/0	0/0	0/0	4/0	2/0	5.0/0	0	0	H	35	Yes	No	32	CC		
LH	2	32	5	14	7/0	3/0	1/0	1/0	1/0	0/0	0/0	0/0	2/0	2/0	11.3/0	0	0	H	35	Yes	No	32	DD		
LH	2	36	5	14	9/0	1/0	1/0	3/1	4/1	1/0	2/0	2/0	1/0	4/1	7.9/0.8	0	0	H	35	Yes	No	32	EE		
LH	2	33	5	13	2/0	2/1	1/0	1/0	2/1	1/0	2/0	0/0	2/0	0/1	5.0/1.2	1	1	H	35	Yes	No	32	FF		
LH	2	19	5	13	1/0	0/0	1/0	2/0	3/1	1/0	2/0	0/0	1/0	7/1	11.2/1.9	1	1	H	35	Yes	No	32	GG		
LH	2	22	5	14	0/0	0/0	0/0	0/0	0/0	0/0	0/0	0/0	0/0	0/0	0/0	0	0	H	35	Yes	No	32	HH		
LH	2	24	5	14	2/0	0/0	0/0	1/0	0/0	1/0	0/0	1/0	4/0	0/0	5.9/0	1	2	H	35	Yes	No	32	II		
LH	2	24	5	12	2/0	0/0	0/0	2/0	0/0	0/0	0/0	0/0	0/0	0/1	3.5/0.7	1	3	H	35	Yes	No	32	JJ		
LH	2	27	5	12	2/0	2/0	1/0	0/0	0/0	1/0	0/0	2/0	4/0	3/1	7.3/0	2	2	H	35	Yes	No	32	KK		
LH	2	27	5	10	0/0	1/0	0/0	2/0	0/0	1/0	0/0	2/0	0/0	1/0	4.0/0	0	0	H	35	Yes	No	32	LL		
LHJ	1	75	8	13	22	6	2	4	5	3	8	0	11	3	9.0	0	2	M	68	Yes	No	34	AA		
RR ⁴	1	70	8	9	5	1	2	1	1	1	1	6	2.5	0	0	H	68	Yes	No	34	BB			
LH	1	60	8	11	10	6	7	4	7	9	6	7	12	7	8.4	3	10	H	68	Yes	No	34	CC		
LH	1	50	8	24	17/11	9/4	6/6	3/11	7/2	1/4	11/30	2/7	4/13	7/9	13.8/20	18	31	H	68	No	Yes	34	DD		
RR	1	60	8	10	37	14	7	17	18	19	23	15	38	17	15.9	0	5	S							

TABLE 4—LIGHTNING PERFORMANCE AND DESIGN FEATURES OF 220-KV LINES*

Ref.	Name of Co. Reporting	Line Designation	Date First in Service	Length of Line R or W Miles	No. of Circuits	Circuits per Structure	Clearing Kv. Phase to Phase	Towers			Insulators			Conductors				Wire Sag			Type of Country	Nature of Soil	Lightning Severity	Isokeraunic Level	Insul. Arcing Devices	
								No. per Line	Type (Fig. No.)	Avg. Span (Feet)	No. per String	Spacing (2) (Inches)	Size (INCH)	Material	Number	Gr. Wire Size (In. or A.C.M.)	Material	Gw. on Avg. Span (Feet)	Cond. of Avg. Span (Feet)	Avg. Elev. above Sea Level (Feet)					Type	Arc. Dist. (Inches)
1	New England Pwr. Serv. Co.	Fifteen Mile Falls—Tewksbury	9-30-30	126.4	2	1	231	1127	1(c)	590	15/17	5%	795	ACSR	2	1/2"	S	12	16	900	Mountains and Hills	Rock-Clay Sand	—	24	Rings	79.5
2	Shawinigan Water and Power Co.	No. 25-26	8-6-27	135.3	2	2	190	796	1(l)	910	10/12	4 3/4/5%	397	ACSR	2	3/8"	S	17	20	1000	Hills Rolling	Gravel	Moderate	15	(3) Horns	(4) 47.5
3	Shawinigan Water and Power Co.	No. 31	1-38	108.1	1	1	240	538	1(c)	1060	16/16	5/5%	795	ACSR	2	3/8"	S	24	29	600	Hills Rolling Flat	Rock Sand	Moderate	15	None	—
4	Shawinigan Water and Power Co.	No. 35	11-40	74.3	1	1	200	388	1(c)	1010	14/16	5/5%	605	ACSR	2	3/8"	S	25	25	200	Rolling Flat	Rock Clay Sand	Moderate	15	None	—
5	Philadelphia Electric Co.	Conowingo-Plymouth—Meeting	3-5-28	57.7	2	1	220	261	1(c)	1170	16/18	5%	795	ACSR	2	184	ACSR	29.2	34.8	360	Rolling	Rock Clay	Moderate	35	Rings	83.3
6	Philadelphia Electric Co.	Plymouth Meeting—Siegfried	2-18-28	9.9	1	1	220	57	1(c)	916	16/18	5%	795	ACSR	2	184	ACSR	18.4	21.9	300	Rolling Flat	Rock Clay	Moderate Severe	35	None	—
6A	Pennsylvania Pwr. & Light Co.	Plymouth Meeting—Siegfried	2-18-28	38.8	1	1	220	186	1(c)	1100	16/18	5%	795	ACSR	2	184	ACSR	29.0	43.0	500	Rolling Flat	Rock Clay	Moderate	35	Rings	82.3
7	Pennsylvania Pwr. & Light Co.	Siegfried-Wallenpaupack Tap—Roseland	4-11-26	66.2	1	1	220	317	1(c)	1100	14-16/16-18/18-20	5%	795	ACSR	2	(21) 184	ACSR CW	18.5	31.5	1000	Mountains Rolling Hills	Rock Clay Sand	Severe	35	Rings & Horns	72.0
7A	Public Serv. Elec. & Gas Co.	Siegfried-Roseland	4-8-32	45.8	1	1	220	211	1(c)	1150	16-18/18-20	5%	795	ACSR	2	203	ACSR	32.9	35.8	700	Rolling	Rock Clay	Moderate	35	Rings	83.3
8-	Public Serv. Elec. & Gas Co.	Plymouth Meeting—Roseland	8-31-30	46.2	1	1	220	235	1(c)	1040	16/18	6	795	ACSR	2	203	ACSR	27.0	29.4	205	Rolling Flat	Clay Sand	Moderate	33	Rings Grade Shield	85.3
8A	Philadelphia Electric Co.	Plymouth Meeting—Roseland	8-31-30	29.6	1	1	220	145	1(c)	1080	16/18	5%	795	ACSR	2	203	ACSR	26.0	29.4	335	Rolling	Rock-Clay	Moderate	35	Rings Grade Shield	83.3
9	Pennsylvania Water & Pwr. Co.	Safe Harbor—Riverside	11-1-37	50.0	1	1	220	281	1(c)	940	20/20	5 1/4/5%	795	ACSR	2	3/8"	CW	17.1	26.5	330	Rolling	Rock-Clay Sand	Severe	36	None	—
10	Pennsylvania Water & Pwr. Co.	Safe Harbor—Takoma Tap—Westport	12-6-31	92.0	1	1	220	477	1(c)	1020	20/20	5 1/4/5%	795	ACSR	2	203	ACSR	21.5	26.5	475	Rolling	Rock-Clay Sand	Severe	36	None	—
11	Commonwealth Edison Co.	Powerton—Chicago	9-28-40	147.0	2	1 & 2	240	761(6)	1(c,l)	1020	18/20	5%	900	ACSR	2	1/2"	CW	9.2 (18A) /26.8	16.6 (18A) /38.6	650	Rolling Flat	Mostly Loam	—	45	None	—
12	Bonneville Pwr. Administration	Covington Coulees No. 1	7-16-42	183.0	1	1	230	850	1(c)	1140	(8) 16/18	5%	795	ACSR	(7)	—	—	—	34	2500	Mountains to Flat	Rock-Clay Sand	Moderate	8	—	—
13	Bonneville Pwr. Administration	Coulees—Spokane 3 & 4	3-15-43	82.8	2	2	230	422	1(l)	1035	16/18	5%	795	ACSR	(7)	—	—	33.5	51.5	2800	Hilly to Flat	Rock-Clay Sand	Moderate	8	(9) 60	
14	City of Los Angeles	Boulder Dam—Los Angeles 1 & 2	10-36	263.5	2	(10) 1 & 2	287.5	2693	1(c,l)	790/970	24/22	5/6	1.4"	CU	2	3/8"	CW	37.8/15.8	45.8/23.6	2400	Mountains to Flat	Rock-Clay Sand	Moderate Light	15	Horns	110
15	City of Los Angeles	Boulder Dam—Los Angeles 3	5-40	263.5	1	1	287.5	1428	1(c)	970	24/22	5/6	1.4"	CU	2	1/2"	S	37.8	45.8	2400	Mountains to Flat	Rock-Clay Sand	Moderate Light	15	Horns	110
16	Pacific Gas & Electric Co.	Pitt Lines No. 1 & 2. Horiz. Config. Sect.	(11) 1923	83	2	1	230	—	1(c)	(13) 720	13/12	5	518	ACSR	0	—	—	—	17	2000	Hills Rolling to Flat	Various	Light	5	Horns Horn or Shield	71
16A	Pacific Gas & Electric Co.	Pitt Lines No. 1 & 2. Vert. Config. Sect.	(12) 11-23	214	2(14)	2	230	—	1(l)	—	13/12	5/5 1/2	500	CU	0	—	—	—	24	200	—	Light	5	Horns Horn or Shield	71	
17	Pacific Gas & Electric Co.	Tiger Creek—Newark. Horiz. Config. Sect.	6-31	16	2	1	230	—	1(c)	(13) 790	13/13	5 1/2	518	ACSR	0	—	—	—	17	2500	Mountains Hills to Flat	Various	Light	5	Disc Shield Disc Shield	71.5
17A	Pacific Gas & Electric Co.	Tiger Creek—Newark. Vert. Config. Sect.	6-31	93	2	2	230	—	1(l)	—	13/13	5 1/2	500	CU	0	—	—	—	24	500	—	Light	5	Disc Shield Disc Shield	71.5	
18	Pacific Gas & Electric Co.	Bucks Creek—Bellota. Horiz. Config. Sect.	(23) 1926	33	1	1	230	—	(23)	—	14/16	5%	795	ACSR	0	—	—	—	17.5	1000	Mountains Rolling to Flat	Rock Various	Light	5	Disc Shield Disc Shield	80.5
18A	Pacific Gas & Electric Co.	Bucks Creek—Bellota. Horiz. Config. Sect.	1-44	110	1	1	230	—	1(l)	—	14/16	5%/5 1/2	795	ACSR	0	—	—	—	24	150	—	Light	5	Disc Shield Disc Shield	77	
18B	Pacific Gas & Electric Co.	Bucks Creek—Bellota. Horiz. Config. Sect.	6-31	102	2	2	230	—	1(l)	—	14/16	5%/5 1/2	500	CU	0	—	—	—	24	150	—	Light	5	Disc Shield Disc Shield	77	
19	Metropolitan Water Dist. of So. Cal.	Boulder	11-1-38	237	1	1	280	945	1(c)	1320	13/15	5%	795	ACSR	(20) 2	1/2"	S	24	35	2000	Hills to Flat	Mostly Clay	Moderate	15	None	—
20	Hydro-Electric Pwr. Commission of Ontario	Paugan—Chatsfalls—Leaside, Hastings—Leaside Sect.	10-1-28	110.7	3	1	220	1666	1(c)	1050	18/18	5/5%	795	ACSR	2	3/8"	S	32	36	600	Hills	Rock Clay Sand Rock Clay Sand	—	25	None	—
20A	Hydro-Electric Pwr. Commission of Ontario	Paugan—Chatsfalls—Leaside, Paugan—Chatsfalls—Hastings Sect.	10-15-31	117.3	2 & 3	1	220	1631	1(c)	1050	18/18	5/5%	795	ACSR	2	3/8"	S	32	36	800	Hills	—	—	25	None	—
21	Hydro-Electric Pwr. Commission of Ontario	Beauharnois—Masson—Chatsfalls	7-1-33	128.2	1	1	220	516	1(c)	1310	18/18	5/5%	795	ACSR	2	3/8"	S	32	36.5	250	Flat	Mostly Clay	—	25	None	—
22	Hydro-Electric Pwr. Comm. of Ontario	Leaside—Burlington	8-41	44.8	2	2	220	273	1(l)	870	18/18	5/5%	500	CU	1	3/8"	S	25.3	34	550	Rolling	Clay	—	25	None	—
23	Hydro-Electric Pwr. Comm. of Ontario	Beauharnois—Leaside	4-9-41	300.5	1	1	220	1404	1(c)	1125	18/18	5/5%	795	ACSR	2	3/8"	S	32	36	250	Hills Rolling Flat	—	—	25	None	—
24	So. Cal. Edison Co., Ltd.	North & South Lighthipe—Lafress	2-27-30	9.7	2	2	220	57	1(l)	900	13/15	—	667	ACSR	1	2/0	CU	12	13	—	Flat	Sand	—	5	Ring & Horn	—
25	So. Cal. Edison Co., Ltd.	Big Creek 2-2A-3	7-15-28	5.9	1	1	220	29	1(c)	1080	13/15	6 1/2	667	ACSR	2	3/0	CU	31	39	2950	Mountains	Rock	Light	5	Ring & Horn	—
26	So. Cal. Edison Co., Ltd.	East & West, Eagle-Bell	1923	26.8	2	1	220	132(27)/128	1(c)	1090	13/15	5%/6 1/2	667	ACSR	1 & 2	1/2"	S	19	23	1490	Mountains to Flat	Rock-Clay Sand	Light	5	Ring & Horn	—
27	So. Cal. Edison Co., Ltd.	Big Creek 3—Magunden	1-24-28	128	1	1	220	457	1(c)	1480	13/15	6 1/2	1034	ACSR	2	1/2"	S	33	34	2630	Mountains to Flat	Rock-Clay Sand	Light	5	Ring & Horn	—
28	So. Cal. Edison Co., Ltd.	Magunden—Eagle Rock	11-14-26	102.6	1	1	220	470	1(c)	1150	13/15	6 1/2	1034	ACSR	(28) 2	1/2"	S	30	31	3020	Mountains to Flat	Rock-Clay Sand	Severe	5	Ring & Horn	—
29	So. Cal. Edison Co., Ltd.	Chino-Barre	9-20-39	26	2	(29) 1 & 2	220	116	1(c,l)	1190	15/16	5%	605	ACSR	(30) 1 & 2	1/2"	S	21	28	905	Hills to Flat	Clay Sand	—	5	Horns	—
30	So. Cal. Edison Co., Ltd.	Chino—Laguna Bell	1-29-42	33.4	1	1	220	132	1(c)	1340	15/15	5%/6 1/2	605	ACSR	1 & 2	1/2"	S	17	23	830	Hills to Flat	Clay Sand	—	5	Ring & Horn	—
31	So. Cal. Edison Co., Ltd.	East & West Lighthipe—Laguna Bell	10-30-27	7.0	2	1	220	68	1(c)	1090	14/15	6 1/2	1034	ACSR	1	1/2"	S	14	16	80	Flat	Sand	—	5	Ring & Horn	—
32	So. Cal. Edison Co., Ltd.	Barre—Lighthipe	8-10-41	15.8	1	1	220	91	1(l)	920	14/15	6 1/2	605	ACSR	1	1/2"	S	12.5	15	68	Flat	Sand	Light	5	Horns	—
33	So. Cal. Edison Co., Ltd.	East & West Big Creek	4-14-14	243.7	2	1	(32) 220	3448	1(c)	700	11/13	5%	667	ACSR	2	1/2"	S	8	11	2870	Mountains to Flat	Rock-Clay Sand	Light	5	Ring & Horn	—
34	So. Cal. Edison Co., Ltd.	East & West Long Beach—Lighthipe	6-16-28	9.8	2	2	220	55	1(l)	945	15/15	6 1/2	650	CU	1	4/0	CU	27	24	—	Flat	Sand	—	5	—	—
35	So. Cal. Edison Co., Ltd.	North & South Boulder—Chino	(33) 11-15-41	233.7	2	1	220	1652	1(c)	750	15/16	5%	605	ACSR	2	1/2"	S	18	31	2870	Mountains to Flat	Rock-Clay Sand	Light	15	Horns	—

Footnotes on page 798.

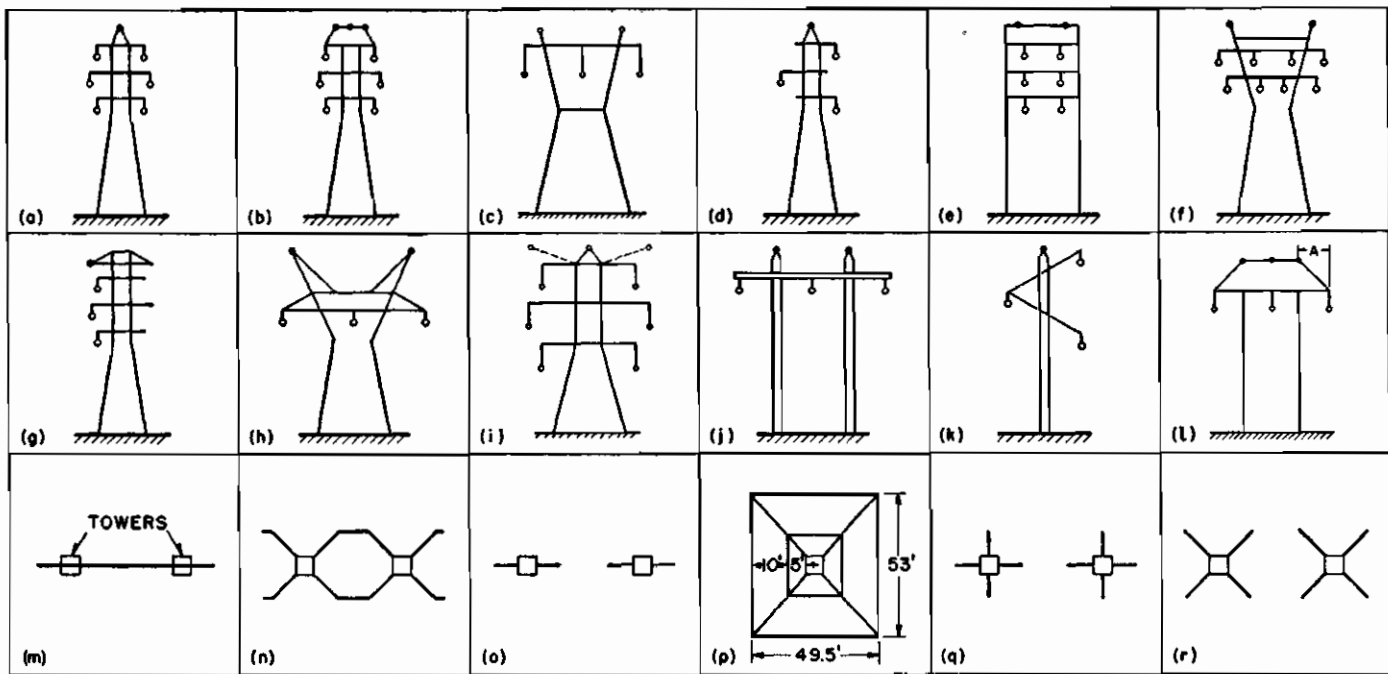

Fig. 1.—Typical transmission structure and counterpoise configurations

FOOTNOTES FOR TABLE 4

*Taken from "Lightning Performance of 220-kv Transmission Lines—II"
by AIEE Subcommittee on Lightning and Insulators, *A.I.E.E. Transactions*, 1946.

1. Suspension assemblies: 12 units after 1943-44.
2. First value suspension; second value dead end.
3. Armor rods on 25 percent of line.
4. 57 inches after 1943-44.
- 4A. 4.8 after 1943-44.
5. 10.5 after 1943-44.
6. 637 towers: 1 circuit per tower. 124 towers: 2 circuits per tower.
7. 1 mile of ground wire at terminals only.
8. 20 percent porcelain, 80 percent glass.
- 8A. Apparently now being added.
9. Experimental devices on 25 percent of line (not described).
10. 222.65 miles: 1 circuit per tower. 40.85 miles: 2 circuits per tower.
11. 60 miles in 1923, 9 miles added in 1925, 14 miles added in January 1944.
12. 142 miles: 2 circuits in 1923. 43 miles: 1 circuit added in March 1944. 29 miles: 2 circuits added in April 1944.
13. Data from 1935: 220-kv paper.
14. Except 43 miles of single circuit.
15. See note 23.
16. Estimated.
17. To August 1, 1945.
18. Data not reported.
- 18A. First value for 2-circuit towers. Second value for 1-circuit towers.
19. To September 1, 1945.
20. Ground wire installed 1943.
21. Line completely equipped with ground wire 1941.
22. Counterpoise as required to reduce resistance to 25 ohms. First 10 miles from Chate Falls only.
23. Operating at 165 kv to January 1944. Tower construction is not shown in Fig. 1. See original reference.
24. 88.5 miles is 3 circuit. 28.8 miles is 2 circuit.
25. First number for outer conductor. Second number for middle conductor.
26. On basis of 50 isokeraunic level.
27. First figure for east line. Second figure for west line.
28. No ground wire for 64 miles of line due to severe sleet loading.
29. 17 miles: 1-circuit towers. 9 miles: 2-circuit towers.
30. 17 miles: 2-ground wires. 9 miles: 1-ground wire.
31. Also some 12 and 14 units of fog type in suspension.
32. Originally designed for 150 kv.
33. North line June 22, 1939.

TRANSFORMER EQUIVALENT CIRCUITS

The procedure to be followed in calculating the impedance values for a transformer equivalent circuit depends on the form of the original data, and whether the final values are to be expressed in ohms or percent. Procedure I, below, is convenient for the simpler cases when the original impedances are expressed in percent on a circuit base and the final values are to be expressed in percent. Procedure II is generally recommended for the more complicated cases, particularly for the ones involving neutral impedances or series transformers. Procedure III may be used when the basic impedance data are expressed in percent on a winding base.

Procedure I. The impedances of two- and three-winding transformers are normally given in percent on a circuit kva base. With the basic data in this form it is convenient to calculate the equivalent-circuit impedance values directly in percent. The equivalent circuits and equations for calculating the sequence quantities are given in Table 5 for 13 of the more common transformer connections. The following notation is employed in the table:

1. Terminal designations.

- Circuit 4—abc terminals.
- Circuit 5—a'b'c' terminals.
- Circuit 6—a''b''c'' terminals.

2. Impedances.

- $Z_{45}\%$ —impedance circuit 4 to circuit 5 in percent on 3-phase rated kva of circuit 4.
- $Z_{46}\%$ —impedance circuit 4 to circuit 6 in percent on 3-phase rated kva of circuit 4.
- $Z_{56}\%$ —impedance circuit 5 to circuit 6 in percent on 3-phase rated kva of circuit 5.
- $Z_1\%$, $Z_0\%$, $Z_{H1}\%$, $Z_{M1}\%$, $Z_{L1}\%$, $Z_{H0}\%$, $Z_{M0}\%$, and $Z_{L0}\%$ are all in percent on the 3-phase rated kva of circuit 4.
- U_4 , U_5 , and U_6 designate the 3-phase kva ratings of circuits 4, 5 and 6, respectively.

The impedances can be converted from one base to another by the relations,

$$\begin{aligned} Z_{45}\% &= \frac{U_4}{U_5} Z_{54}\% \\ Z_{56}\% &= \frac{U_5}{U_6} Z_{65}\% \\ Z_{46}\% &= \frac{U_4}{U_6} Z_{64}\% \end{aligned}$$

Procedure II. In many cases, particularly the ones involving neutral impedances or series transformers, less confusion results if the equivalent-circuit impedance values are calculated in ohms, rather than in percent. However, as the basic data are normally in percent, it is first necessary to convert to ohms using the following relations:

$$\begin{aligned} Z_{45} &= \frac{10Z_{45}\%E_4^2}{U_4} \\ Z_{46} &= \frac{10Z_{46}\%E_4^2}{U_4} \\ Z_{56} &= \frac{10Z_{56}\%E_5^2}{U_5}, \text{ where} \end{aligned}$$

$Z_{45}\%$, $Z_{46}\%$, $Z_{56}\%$ are as defined in I.

E_4 , E_5 and E_6 = line-to-line voltages, in kv, in circuits 4, 5 and 6, respectively.

U_4 , U_5 and U_6 = 3-phase kva ratings of circuits 4, 5 and 6, respectively.

Z_{45} = impedance between circuits 4 and 5 in ohms on circuit 4 voltage base.

Z_{46} = impedance between circuits 4 and 6 in ohms on circuit 4 voltage base.

Z_{56} = impedance between circuits 5 and 6 in ohms on circuit 5 voltage base.

The equations in Table 7 are expressed in terms of the impedances between windings, rather than circuits, so the second step requires converting the ohmic impedances to a winding base. Conversion factors are given in Table 6 for the cases included in Table 5. After this conversion is made, the ohmic impedances can be substituted directly in the equations in Columns 3 and 5 of Table 7.

Procedure III. Table 7 includes in Columns 4 and 6, equivalent circuits based on impedance values expressed in percent on a winding base. These circuits may be employed when the basic data are expressed in this manner.

TABLE 5—TRANSFORMER EQUIVALENT CIRCUITS USED IN PROCEDURE I

TWO-CIRCUIT TRANSFORMERS			
DESCRIPTION	DIAGRAM OF CONNECTIONS	POSITIVE-SEQUENCE EQUIVALENT CIRCUIT	ZERO-SEQUENCE EQUIVALENT CIRCUIT
A-1 STAR/STAR SOLIDLY GROUNDED NEUTRALS (FOR 3 PHASE CORE TYPE SEE TABLE 7)		 $Z_1\% = Z_{45}\%$	 $Z_0\% = Z_{45}\%$
A-4 STAR/STAR NEUTRALS CONNECTED BUT UNGROUNDED (FOR 3 PHASE CORE TYPE SEE TABLE 7)		SAME AS A-1	 $Z_0\% = \infty$
A-5 STAR/DELTA SOLIDLY GROUNDED NEUTRAL		 $Z_1\% = Z_{45}\%$	 $Z_0\% = Z_{45}\%$
A-6 DELTA/STAR SOLIDLY GROUNDED NEUTRAL		SAME AS A-5	 $Z_0\% = Z_{45}\%$
A-7 DELTA-DELTA		SAME AS A-1	SAME AS A-4
TWO-CIRCUIT AUTOTRANSFORMERS			
B-1 STAR/STAR SOLIDLY GROUNDED NEUTRAL (FOR 3 PHASE CORE TYPE SEE TABLE 7)		SAME AS A-1	SAME AS A-1
B-3 STAR/STAR UNGROUNDED NEUTRAL (FOR 3 PHASE CORE TYPE SEE TABLE 7)		SAME AS A-1	SAME AS A-4
THREE-CIRCUIT TRANSFORMER			
C-1 STAR/STAR/ STAR SOLIDLY GROUNDED NEUTRALS		 $Z_{M1}\% = \frac{1}{2} [Z_{45}\% + Z_{46}\% - \frac{U_4}{U_5} Z_{56}\%]$ $Z_{L1}\% = \frac{1}{2} [Z_{46}\% + \frac{U_4}{U_5} Z_{56}\% - Z_{45}\%]$ $Z_{H1}\% = \frac{1}{2} [\frac{U_4}{U_5} Z_{56}\% + Z_{45}\% - Z_{46}\%]$	 $Z_{M0}\% = Z_{M1}\%$ $Z_{L0}\% = Z_{L1}\%$ $Z_{H0}\% = Z_{H1}\%$

TABLE 5 CONT'D

THREE-CIRCUIT TRANSFORMERS (CONT'D.)			
DESCRIPTION	DIAGRAM OF CONNECTIONS	POSITIVE-SEQUENCE EQUIVALENT CIRCUIT	ZERO SEQUENCE EQUIVALENT CIRCUIT
C-3 STAR / STAR / DELTA SOLIDLY GROUNDED NEUTRALS		 $Z_{M1}\% = \frac{1}{2} \left[Z_{45}\% + Z_{46}\% - \frac{U_4}{U_5} Z_{56}\% \right]$ $Z_{L1}\% = \frac{1}{2} \left[Z_{46}\% + \frac{U_4}{U_5} Z_{56}\% - Z_{45}\% \right]$ $Z_{H1}\% = \frac{1}{2} \left[\frac{U_4}{U_5} Z_{56}\% + Z_{45}\% - Z_{46}\% \right]$	 $Z_{M0}\% = Z_{M1}\%$ $Z_{L0}\% = Z_{L1}\%$ $Z_{H0}\% = Z_{H1}\%$
C-6 DELTA / STAR / DELTA SOLIDLY GROUNDED NEUTRAL		 $Z_{M1}\% = \frac{1}{2} \left[Z_{45}\% + Z_{46}\% - \frac{U_4}{U_5} Z_{56}\% \right]$ $Z_{L1}\% = \frac{1}{2} \left[Z_{46}\% + \frac{U_4}{U_5} Z_{56}\% - Z_{45}\% \right]$ $Z_{H1}\% = \frac{1}{2} \left[\frac{U_4}{U_5} Z_{56}\% + Z_{45}\% - Z_{46}\% \right]$	 $Z_{M0}\% = Z_{M1}\%$ $Z_{L0}\% = Z_{L1}\%$ $Z_{H0}\% = Z_{H1}\%$
C-7 DELTA / DELTA / DELTA		SAME AS C-1	 $Z_{M0}\% = Z_{M1}\%$ $Z_{L0}\% = Z_{L1}\%$ $Z_{H0}\% = Z_{H1}\%$
THREE-CIRCUIT AUTOTRANSFORMERS			
D-1 STAR / STAR / DELTA SOLIDLY GROUNDED NEUTRAL		 $Z_{M1}\% = \frac{1}{2} \left[Z_{45}\% + Z_{46}\% - \frac{U_4}{U_5} Z_{56}\% \right]$ $Z_{L1}\% = \frac{1}{2} \left[Z_{46}\% + \frac{U_4}{U_5} Z_{56}\% - Z_{45}\% \right]$ $Z_{H1}\% = \frac{1}{2} \left[\frac{U_4}{U_5} Z_{56}\% + Z_{45}\% - Z_{46}\% \right]$	 $Z_{M0}\% = Z_{M1}\%$ $Z_{L0}\% = Z_{L1}\%$ $Z_{H0}\% = Z_{H1}\%$
D-2 STAR / STAR / DELTA UNGROUNDED NEUTRAL		SAME AS D-1	 $N' = \frac{E_5}{E_4}$ $Z_0\% = N'(N'-1) \left[\frac{U_4}{U_5} Z_{56}\% - \frac{Z_{46}\%}{N'} + \frac{Z_{45}\%}{N'-1} \right]$

TABLE 6—CONVERTING OHMIC IMPEDANCES TO A WINDING BASE

Case	Conversion	Case	Conversion
A-1, A-2, A-3, A-4, A-5	$Z_{FS} = Z_{45}$ (a)	C-9	(g) Obtain Z_{M1} , Z_{H1} and Z_{L1} as for Case C-8.
A-6, A-7	$Z_{FS} = 3Z_{45}$	D-1	
A-8	(b)	D-2	Obtain Z_{M1} , Z_{H1} and Z_{L1} as for Case C-8.
A-9	$Z_1 = Z_{45}$ (c) $Z_{ST} = Z_0'$ (d)		$Z_{ST} = N'(N'-1) \left[\frac{Z_{56}}{(N')^2} - \frac{Z_{45}}{N'} + \frac{Z_{45}}{N'-1} \right]$
A-10	$Z_1 = Z_{45}$ (c)(e)		
B-1, B-2, B-3	$Z_{FS} = \frac{N^2}{(N-1)^2} Z_{45}$ (a)	D-3	$Z_{FS} = Z_{TS} = \frac{1}{2}Z_{45} + 3Z_{45}$ $Z_{FT} = Z_{45}$
B-4, B-5	$Z_1 = Z_{45}$ (a)(c)	D-4	
C-1, C-2, C-3, C-4, C-5	$Z_{FS} = Z_{45}$ $Z_{FT} = Z_{45}$ $Z_{ST} = Z_{56}$	E-7	(g) $Z_1 = Z_{45}$ $Z_{FS} = \left(\frac{N}{N-1} \right)^2 Z_{45}$ $Z_{FT} = Z_{45}$ $Z_{ST} = N(N-1) \left[\frac{Z_{56}}{N^2} - \frac{Z_{45}}{N} + \frac{Z_{45}}{N-1} \right]$
C-6	$Z_{FS} = 3Z_{45}$ $Z_{FT} = 3Z_{45}$ $Z_{ST} = Z_{56}$		
C-7	$Z_{FS} = 3Z_{45}$ $Z_{FT} = 3Z_{45}$ $Z_{ST} = 3Z_{56}$	E-8	See E-7, above
C-8	$Z_{M1} = \frac{1}{2} \left[Z_{45} + Z_{45} - \left(\frac{E_4}{E_5} \right)^2 Z_{56} \right]$ $Z_{H1} = \frac{1}{2} \left[Z_{45} + \left(\frac{E_4}{E_5} \right)^2 Z_{56} - Z_{45} \right]$ $Z_{L1} = \frac{1}{2} \left[Z_{45} + \left(\frac{E_4}{E_5} \right)^2 Z_{56} - Z_{45} \right]$ $Z_{ST} = Z_{56}$ (f)	E-9 to G-6	See note (h)

a In the case of three-phase core-form transformers, the complete zero-sequence equivalent circuit includes impedances that are a function of the zero-sequence exciting characteristics of the transformer. These impedances are therefore affected by the magnitude of the zero-sequence voltage applied to the transformer windings during fault conditions. In any accurate calculation of zero-sequence currents or voltages it is necessary to represent these impedances by a saturation curve rather than by a fixed impedance, which results in a step-by-step analytical solution. In cases where the three-phase core-form transformer has a delta tertiary, or where other ground sources are present, satisfactory results can be obtained by neglecting the zero-sequence exciting impedances of the transformer. If this procedure is followed the transformer is treated as three single-phase units or a three-phase shell-form unit.

b The rating of a zig-zag grounding bank is normally expressed in terms of line-to-line voltage and neutral amperes. In the case of standard grounding transformers which have 100 percent impedance,

$$Z_{FS} = \frac{\sqrt{3}E}{I_n} \text{ where}$$

E = line-to-line voltage in kv.

I_n = neutral current in amperes.

When a zig-zag transformer has less than 100 percent impedance, Z_{FS} must be modified accordingly.

c In many cases it is simpler to obtain the sequence impedances directly from the circuit impedances without converting the latter to a circuit base.

d When a transformer has a zig-zag winding the manufacturer should furnish the zero-sequence impedance as viewed from the zig-zag side.

e Obtain Z_{ST} as in Case A-9 for a solidly grounded transformer.

f The manufacturer should furnish the zero-sequence impedance of the transformer as viewed from the zig-zag side. Z_{FT} is then equal to this impedance expressed in ohms.

g Refer to manufacturer.

h In those cases involving series transformers, the exciting transformer and the series transformer should be treated as separate units when deriving the basic impedance data. To obtain the conversion factors for the exciting transformer, refer to the two or three-winding transformer case employing the same connections.

In furnishing impedance data on a series transformer, the manufacturer will usually treat the unit as a simple two-winding transformer. The impedance is usually expressed in percent on a kva base corresponding to the parts used in the series transformer. The percent impedance is based on the voltage rating of the winding to be connected in the main power circuit. For example, in Case E-9, the rated voltage of the V winding is used in obtaining the percent impedance. This impedance is converted to ohms as follows:

$$Z_{vw} = \frac{10E_v^2 Z_{vw}\%}{U_v} \text{ where}$$

E_v = kv rating of the V winding (actual winding voltage in the case of single-phase series transformers and $\sqrt{3}$ times winding voltage in the case of three-phase series transformers).

U_v = kva rating of the series transformer (per-phase rating for single-phase transformers and three-phase rating for three-phase transformers).

TABLE 7—EQUIVALENT CIRCUITS OF POWER AND REGULATING TRANSFORMERS

Convention of Notation and Definitions of Symbols

In all cases the left hand circuit (terminals $a-b-c$) is taken as the input circuit; and the remaining circuits (terminals $a'-b'-c'$ and $a''-b''-c''$) are taken as output circuits. It is assumed that the transformation ratios will always be step up from the input to the output circuit (terminals $a'-b'-c'$), and, if shift in phase is involved, the phase angle will be advanced. If the actual conditions differ from those assumed suitable corrections may be readily applied.

The a terminal designates the reference phase of the input circuit; the a' and a'' terminals designate the reference phases of the output circuits.

Individual windings are designated, as for example:

$P(1)$ denotes the P winding, the number of turns of which is proportional to unity.

$S(n_1)$ denotes the S winding, the number of turns of which is proportional to n_1 .

Windings drawn parallel in the diagram of connections are on the same magnetic core; except that for those arrangements involving series transformers all six windings for the three series transformers are drawn parallel and only those windings drawn adjacent to each other are on the same magnetic core.

$I_a, I_a',$ and I_a'' are the line currents in the reference phases at the terminals $a, a',$ and a'' , respectively.

$E_{ag}, E_{ag}',$ and E_{ag}'' are line-to-ground voltages of the reference phases at the terminals $a, a',$ and a'' , respectively.

The ideal transformers included in the equivalent circuits serve only to maintain proper voltage and current relationships, in magnitude and phase, between the input and output circuits. The ideal transformer is defined as having infinite exciting impedance, zero leakage impedance, and zero exciting or no-load current.

$1:N$ ($1:N'$, etc.) is the turns ratio of the ideal transformer in the equivalent circuit maintaining nominal current and voltage relationships between two circuits.

N (N', N'' , etc.) is the overall transformation ratio of the transformer bank at no load.

$e^{j\alpha}$ represents a phase angle transformation of α degrees.

α (α', α'' , etc.) is the phase angle difference between output and input voltages of the transformer bank at no load.

$I_1, I_0,$ and I_2 are symmetrical components of the line currents at the $a-b-c$ terminals.

$I_1', I_0',$ and I_2' are symmetrical components of the line currents at the $a'-b'-c'$ terminals.

$I_1'', I_0'',$ and I_2'' are symmetrical components of the line currents at the $a''-b''-c''$ terminals.

$E_1, E_0,$ and E_2 are symmetrical components of the line-to-ground voltages at the $a-b-c$ terminals.

$E_1', E_0',$ and E_2' are symmetrical components of the line-to-ground voltages at the $a'-b'-c'$ terminals.

$E_1'', E_0'',$ and E_2'' are symmetrical components of the line-to-ground voltages at the $a''-b''-c''$ terminals.

Z_1 is the equivalent positive- (or negative-) sequence impedance as viewed from the input ($a-b-c$) terminals, expressed in ohms.

Z_1' is the equivalent positive- (or negative-) sequence impedance as viewed from the output ($a'-b'-c'$) terminals, expressed in ohms.

Z_0 (Z_{H0}, Z_{L0}, Z_{M0} , etc.) is the equivalent zero sequence impedance (or a constituent part of the equivalent circuit) as viewed from the input ($a-b-c$) terminals.

Z_0' ($Z_{H0}', Z_{L0}', Z_{M0}'$, etc.) is the equivalent zero sequence impedance (or a constituent part of the equivalent circuit) as viewed from the output ($a'-b'-c'$) circuit.

Z_{PS} (Z_{PT}, Z_{VW} , etc.) is the leakage impedance between the P and S windings, as measured in ohms on the P winding with the S winding short-circuited, all other windings on the same core being open-circuited.

Z_{SP} is the leakage impedance between the S and P windings, as measured in ohms on the S winding with the P winding short-circuited, all other windings on the same core being open-circuited.

Z_{PE} (Z_{BE}, Z_{VE} , etc.) is the exciting impedance as measured on the P winding, with all other windings on the same core open circuited and zero sequence voltage applied to the terminals of the three windings one of which is designated by P , connected to form a three-phase unit.

Z_{GP} (Z_{GS}, Z_G , etc.) is the impedance, in ohms, connected between the neutral of a star winding and ground.

$I_1^{1/1}, I_0^{1/1},$ and $I_2^{1/1}$, are symmetrical components of the line currents at the $a-b-c$ terminals, expressed in per unit. Thus $I_1^{1/1} = \frac{I_1}{I_N}$,

where I_N is the base (or normal) current for the input circuit, corresponding to the base (or normal) kva, U_c , and voltage of that circuit. Similar definitions apply for $I_1^{1'/1}, I_0^{1'/1}, I_2^{1'/1}, I_1^{1''/1}$, etc.

$E_1\%, E_0\%,$ and $E_2\%$, are symmetrical components of the line-to-ground voltages at the input ($a-b-c$) terminals, expressed in per cent of the base, or normal) voltage for the input circuit. Similar definitions apply for $E_1'\%, E_1''\%$, etc.

$Z_1\%$ is the equivalent positive- (or negative-) sequence impedance as viewed from the input ($a-b-c$) terminals, expressed in per cent on the base (or normal) kva. and voltage of the input circuit.

$Z_1'\%$ is the equivalent positive- (or negative-) sequence impedance as viewed from the output ($a'-b'-c'$) terminals, expressed in per cent on the base (or normal) kva. and voltage of the output circuit.

$Z_0\%$ is the equivalent zero-sequence impedance as viewed from the input ($a-b-c$) terminals, expressed in per cent on the base (or normal) kva. and voltage of the input circuit.

$Z_0'\%$ is the equivalent zero-sequence impedance as viewed from the output ($a'-b'-c'$) circuit, expressed in per cent on the base (or normal) kva. and voltage of the output circuit.

$Z_{PS}\%$ ($Z_{PT}\%, Z_{VW}\%$, etc.) is the leakage impedance between the P and S windings, expressed in per cent on the kva. and voltage at which the P winding is operating.

$Z_{SP}\%$ is the leakage impedance between the P and S windings, expressed in per cent on the kva. and voltage at which the S winding is operating.

$Z_{PE}\%$ ($Z_{BE}\%, Z_{VE}\%$, etc.) is the exciting impedance of the P winding as defined under Z_{PE} expressed in per cent on the kva. and voltage at which the P winding is operating.

Note: To use the equations as given, the base (or normal) kva. must be assumed for all circuits, and the base (or normal) voltages of the circuits must be related by the transformation ratios indicated on the equivalent circuit for positive sequence. The operating kva. and voltage for an individual winding must be taken as the value existing in the winding when the base (or normal) kva. assumed for the circuit is being transmitted through the transformer. The assumed base kva. for the circuit, and the corresponding winding kva's, may be either three-phase or single phase values, but consistency must be maintained.

U_c is the base (or normal) kva. of the input circuit (at the $a-b-c$ terminals).

U' is the base (or normal) kva. of the output circuit (at the $a'-b'-c'$ terminals).

U'' is the base (or normal) kva. of the output circuit (at the $a''-b''-c''$ terminals).

U_P (U_B, U_T, U_V, U_W , etc.) is the kva. at which the P winding is operating when the input circuit carries U_c kva.

Note: When the above quantities appear in equations, all must be in three phase quantities, or all in single phase quantities.

Z_{NC} is the base (or normal) impedance, in ohms, corresponding to the base kva. and voltage of the input circuit (at the $a-b-c$ terminals).

The equivalent circuit for negative sequence is identical with that shown for positive sequence, except that when a shift in phase angle is involved, the phase angle shift in the equivalent circuit for negative sequence shall be taken with the opposite sign to that indicated in the equivalent circuit for positive sequence (for example, instead of α use $-\alpha$, instead of 30° use -30° , etc.).

TABLE 7 CONT'D—TWO-CIRCUIT TRANSFORMERS

DESCRIPTION	DIAGRAM OF CONNECTIONS	POSITIVE-SEQUENCE EQUIVALENT CIRCUIT		ZERO-SEQUENCE EQUIVALENT CIRCUIT	
		Expressed in Ohms	Expressed in Per Cent	Expressed in Ohms	Expressed in Per Cent
A-1 STAR/STAR. SOLIDLY GROUND NEUTRALS (FOR 3 PHASE CORE TYPE, SEE A-3)		 $N = n$ $Z_1 = Z_{ps}$ $Z_2' = n^2 Z_{ps} = 2z_p$	$Z_1\% = Z_{ps}\%$ $Z_2\% = Z_{ps}\%$	 $N = n$ $Z_0 = 2z_p$ $Z_0' = 2z_p + n^2 z_0$	$Z_0\% = 2z_p\%$
A-2 STAR/STAR. IMPEDANCE - GROUNDED NEUTRALS. (FOR 3 PHASE CORE TYPE, SEE A-3)		SAME AS A-1	SAME AS A-1	 $N = n$ $Z_0 = 2z_p + 3Z_{cp} + \frac{3(N-1)^2 Z_0}{N^2}$ $Z_0' = 2z_p + 3N^2 Z_{cp} + 3Z_{cs} + 3(N-1)^2 Z_0 + n^2 z_0$	$Z_0\% = 2z_p\% + 3Z_{cp}\% + 3Z_{cs}\%$ $+ \frac{3(N-1)^2 Z_0\%}{N^2} \times 100$
A-3 STAR/STAR. IMPEDANCE - GROUNDED NEUTRALS. (3 PHASE CORE TYPE)		SAME AS A-1	SAME AS A-1	 $N = n$ APPROXIMATE EXPRESSIONS $Z_{L0} = \frac{1}{2} Z_{ps} + 3Z_{cp} + \frac{3(N-1)^2 Z_0}{N^2}$ $Z_{L0}' = \frac{1}{2} Z_{ps} + \frac{3}{N^2} [3Z_{cs} - 3(N-1)Z_0]$ $Z_{L00} = Z_{L0} - \frac{1}{2} Z_{ps} + \frac{3}{N^2} Z_0$ $= \frac{1}{2} Z_{ps} + \frac{3}{N^2} Z_0$ IF $Z_{ps} = \frac{1}{2} Z_{ps}$ USE $\frac{1}{2} (Z_{ps} + \frac{3}{N^2} Z_0)$ IN EITHER OF ABOVE	APPROXIMATE EXPRESSIONS $Z_{L0}\% = \frac{1}{2} Z_{ps}\% + 3Z_{cp}\% + \frac{3(N-1)^2 Z_0\%}{N^2} \times 100$ $Z_{L00}\% = Z_{L0}\% - \frac{1}{2} Z_{ps}\% + \frac{3}{N^2} Z_0\% \times 100$ $= Z_{ps}\% + \frac{3}{N^2} Z_0\% \times 100 = \frac{1}{2} Z_{ps}\%$ IF $Z_{ps}\% = \frac{1}{2} Z_{ps}\%$ USE $\frac{1}{2} (Z_{ps}\% + Z_0\%)$ IN EITHER OF ABOVE
A-4 STAR/STAR. NEUTRALS CONNECTED BUT UNGROUND.		SAME AS A-1	SAME AS A-1	 $N = n$ APPROXIMATE EXPRESSIONS $Z_0 = (N-1)^2 Z_{ps} + n^2 z_0$ $Z_0' = \infty$ EXCEPT FOR 3 PHASE CORE TYPE Z_0 AND Z_0' ARE NOT TRANSFORMED	APPROXIMATE EXPRESSIONS $Z_0\% = (N-1)^2 Z_{ps}\% + n^2 z_0\%$ $Z_0'\% = \infty$ EXCEPT FOR 3 PHASE CORE TYPE
A-5 STAR/DELTA.		 $N = \frac{n}{\sqrt{3}}$ $Z_1 = Z_{ps}$ $Z_2' = N^2 Z_{ps} = \frac{1}{3} Z_{ps}$	$Z_1\% = Z_{ps}\%$ $Z_2\% = \frac{1}{3} Z_{ps}\%$	 $Z_0 = 2z_p + 3Z_{cp}$ $Z_0' = \infty$	$Z_0\% = 2z_p\% + 3Z_{cp}\%$ $Z_0'\% = \infty$
A-6 DELTA/STAR		 $N = \sqrt{3}n$ $Z_1 = \frac{1}{3} Z_{ps}$ $Z_2' = N^2 Z_1 = Z_{ps}$	$Z_1\% = \frac{1}{3} Z_{ps}\%$ $Z_2\% = Z_{ps}\%$	 $Z_0 = \infty$ $Z_0' = Z_{ps} + 3Z_{cs}$	$Z_0\% = \infty$ $Z_0'\% = Z_{ps}\% + 3Z_{cs}\%$
A-7 DELTA/DELTA		 $N = n$ $Z_1 = \frac{1}{3} Z_{ps}$ $Z_2' = N^2 Z_1 = \frac{1}{3} Z_{ps}$	$Z_1\% = \frac{1}{3} Z_{ps}\%$ $Z_2\% = \frac{1}{3} Z_{ps}\%$	 $Z_0 = \infty$ $Z_0' = \infty$ $Z = \frac{1}{3} Z_{ps}$	$Z_0\% = \infty$ $Z_0'\% = \infty$ $Z\% = \frac{1}{3} Z_{ps}\%$
A-8 ZIG-ZAG GROUNDING		 $N = \sqrt{3}n$ $Z_1 = \frac{1}{3} [Z_{ps} + 2z_p + \frac{2}{N^2} Z_0]$ $Z_2' = N^2 Z_1$	$Z_1\% = \frac{1}{3} [Z_{ps}\% + 2z_p\% + \frac{2}{N^2} Z_0\%]$ $Z_2\% = Z_1\%$	 $Z_0 = \infty$ $Z_0' = 2z_p$	$Z_0\% = \infty$ $Z_0'\% = \frac{2}{3} z_p\%$
A-9 STAR/ZIG-ZAG SOLIDLY GROUND NEUTRALS. (FOR 3 PHASE CORE TYPE, SEE A-1)		 $N = \sqrt{3}n$ $Z_1 = \frac{1}{3} [Z_{ps} + 2z_p + \frac{2}{N^2} Z_0]$ $Z_2' = N^2 Z_1$	$Z_1\% = \frac{1}{3} [Z_{ps}\% + 2z_p\% + \frac{2}{N^2} Z_0\%]$ $Z_2\% = Z_1\%$	 $Z_0 = \infty$ $Z_0' = 2z_p$	$Z_0\% = \infty$ $Z_0'\% = \frac{2}{3} z_p\%$
A-10 STAR/ZIG-ZAG IMPEDANCE GROUND NEUTRALS (FOR 3 PHASE CORE TYPE, SEE A-1)		SAME AS A-9	SAME AS A-9	 $Z_0 = \infty$ $Z_{L0} = 2z_p + 3Z_{cp}$ $Z_{L0}' = 3Z_0$ $Z_0' = Z_{L0}' + Z_{L0}'' = 2z_p + 3(Z_{cp} + Z_0)$	$Z_0\% = \infty$ $Z_{L0}\% = 2z_p\% + 3Z_{cp}\%$ $Z_{L00}\% = 3Z_0\%$ $Z_0'\% = Z_{L0}'\% + Z_{L0}''\%$

TABLE 7 CONT'D—AUTOTRANSFORMERS

DESCRIPTION	DIAGRAM OF CONNECTIONS	POSITIVE-SEQUENCE EQUIVALENT CIRCUIT		ZERO-SEQUENCE EQUIVALENT CIRCUIT	
		Expressed in Ohms	Expressed in Per Cent	Expressed in Ohms	Expressed in Per Cent
<p>B-1</p> <p>STAR/STAR, GROUNDED NEUTRAL FOR 3 PHASE CORE TYPE, SEE B-2</p> <p>PARTS RATIOS</p> $\frac{U_2}{U_1} = \frac{N_2}{N_1}$ $\frac{U_3}{U_1} = \frac{N_3}{N_1}$		$N = 1+n$ $Z_1 = \frac{N-1}{N} Z_{ps} + \frac{N-1}{N} Z_{st}$ $Z_1' = N^2 Z_1$	$Z_1 = \frac{N-1}{N} Z_{ps} + \frac{N-1}{N} Z_{st}$ $Z_1' = Z_1$	$N = 1+n$ $Z_0 = \frac{N-1}{N} (Z_{ps} + 3Z_0)$ $Z_0' = 3N^2 Z_0$	$Z_0 = \frac{N-1}{N} Z_{ps} + \frac{3(N-1)}{N} Z_0$ $Z_0' = 3N^2 Z_0$
<p>B-2</p> <p>STAR/STAR, GROUNDED NEUTRAL, 3 PHASE CORE TYPE.</p> <p>PARTS RATIOS SAME AS B-1</p>		SAME AS B-1	SAME AS B-1	$N = 1+n$ <p>APPROXIMATE EXPRESSIONS</p> $Z_{ps} = \frac{N-1}{N} Z_{ps} + \frac{3(N-1)}{N} Z_0$ $Z_{st} = \frac{N-1}{N} Z_{st} + \frac{3(N-1)}{N} Z_0$ $Z_{so} = 2Z_0 + \frac{N-1}{N} Z_{ps} + \frac{3}{N} Z_0$	<p>APPROXIMATE EXPRESSIONS</p> $Z_{so} = \frac{1}{2} Z_{ps} + \frac{3(N-1)}{2N} Z_0 \times 100$ $Z_{st} = \frac{N-2}{2N} Z_{ps} + \frac{3(N-1)}{2N} Z_0 \times 100$ $Z_{so} = 2Z_0 + \frac{N-1}{2N} Z_{ps} + \frac{3(N-1)}{2N} Z_0 \times 100$
<p>B-3</p> <p>STAR/STAR, UNGROUNDED NEUTRAL.</p> <p>PARTS RATIOS SAME AS B-1</p>		SAME AS B-1	SAME AS B-1	$Z_0' = Z_0$ $Z_0 = Z_0$ $Z_{so} = \infty$ EXCEPT FOR 3 PHASE CORE TYPE. $Z_0 \text{ AND } Z_0' \text{ ARE NOT TRANSFORMED.}$	$N = 1+n$ $Z_0' = N^2 Z_0$ $Z_0 = \frac{1}{N} Z_0 + \frac{3(N-1)}{N} Z_0$ $Z_{so} = \infty$ EXCEPT FOR 3 PHASE CORE TYPE.
<p>B-4</p> <p>STAR/STAR, TWO SERIES WINDINGS, GROUNDED NEUTRAL.</p> <p>PARTS RATIOS</p> $\frac{U_2}{U_1} = \frac{N_2}{N_1}$ $\frac{U_3}{U_1} = \frac{N_3}{N_1}$		$N = \frac{1+n_1+n_2}{1+n_1}$ $Z_1 = \frac{N-1}{N} Z_{ps} + \frac{N-1}{N} Z_{st} + \frac{n_2}{N} Z_{st}$ $Z_1' = N^2 Z_1$	<p>NOTE THIS APPLIES ONLY WHEN $n_2 > n_1$</p> $Z_1 = \frac{N-1}{1+n_1} Z_{ps} + \frac{n_2}{1+n_1} Z_{st} + \frac{N-1}{1+n_1} Z_{st}$ $Z_1' = Z_1$	$N = \frac{1+n_1+n_2}{1+n_1}$ $Z_0 = Z_1 + 3 \frac{N-1}{N} Z_0$ $Z_0' = N^2 Z_0 + 3N^2 Z_0$	$Z_0 = Z_1 + 3 \frac{N-1}{N} Z_0$ $Z_0' = 3N^2 Z_0$
<p>B-5</p> <p>STAR/STAR, TWO SERIES WINDINGS, GROUNDED NEUTRAL 3 PHASE CORE TYPE</p> <p>PARTS RATIOS SAME AS B-4</p>		SAME AS B-4	SAME AS B-4	$N = \frac{1+n_1+n_2}{1+n_1}$ $Z_{so} = 3 + N^2 Z_{ps} + \frac{1}{2} (3 + N^2 - 1) (Z_{ps} + Z_{st})$ $- \frac{1}{2} Z_{st} + \frac{3}{2} Z_0$ $Z_{so} = \frac{N-1}{2N} (N-1+n_1) Z_{ps} + (N-1+n_1) Z_{st}$ $- \frac{1}{2} Z_{st} + \frac{3(N-1)}{2N} Z_0$ $Z_{so} = \frac{N-1}{2N} (N-1+n_1) Z_{ps} + (N-1+n_1) Z_{st}$ $- \frac{1}{2} Z_{st} + \frac{3(N-1)}{2N} Z_0$	<p>NOTE THIS APPLIES ONLY WHEN $n_2 > n_1$</p> $Z_{so} = \frac{1}{2} (N-1) [N Z_{ps} + \frac{1}{2} (1 + \frac{N-1}{N}) (Z_{ps} + Z_{st}) + 3Z_0]$ $+ \frac{N-1}{2N} Z_{st} + \frac{3}{2} Z_0 \times 100$ $Z_{so} = \frac{N-1}{2N} (N-1+n_1) Z_{ps} + (N-1+n_1) Z_{st}$ $- \frac{1}{2} Z_{st} + \frac{3(N-1)}{2N} Z_0 \times 100$ $Z_{so} = \frac{N-1}{2N} (N-1+n_1) Z_{ps} + (N-1+n_1) Z_{st}$ $- \frac{1}{2} Z_{st} + \frac{3(N-1)}{2N} Z_0 \times 100$
<p>D-1</p> <p>STAR/STAR/DELTA, GROUNDED NEUTRAL</p> <p>PARTS RATIOS</p> $\frac{U_2}{U_1} = \frac{N_2}{N_1}$ $\frac{U_3}{U_1} = \frac{N_3}{N_1}$ <p>(VECTORIAL SUBTRACTION)</p>		$N = 1+n$ $N' = \frac{2N}{N-1}$ $Z_{s1} = \frac{N-1}{2N} [Z_{ps} + Z_{st} + \frac{2Z_0}{N-1}]$ $Z_{s2} = \frac{N-1}{2N} [Z_{ps} + Z_{st} + \frac{2Z_0}{N-1}]$ $Z_{s3} = \frac{N-1}{2N} [Z_{ps} + Z_{st} + \frac{2Z_0}{N-1}]$ $Z_{L1} = \frac{N-1}{2N} [Z_{ps} + Z_{st} + \frac{2Z_0}{N-1}]$	$Z_{s1} = \frac{N-1}{2N} [Z_{ps} + Z_{st} + \frac{2Z_0}{N-1}]$ $Z_{s2} = \frac{N-1}{2N} [Z_{ps} + Z_{st} + \frac{2Z_0}{N-1}]$ $Z_{s3} = \frac{N-1}{2N} [Z_{ps} + Z_{st} + \frac{2Z_0}{N-1}]$ $Z_{L1} = \frac{N-1}{2N} [Z_{ps} + Z_{st} + \frac{2Z_0}{N-1}]$	$N = 1+n$ $Z_0 = \infty$ $Z_{so} = Z_{s1} + \frac{3(N-1)}{2N} Z_0$ $Z_{so} = Z_{s1} - \frac{3(N-1)}{2N} Z_0$ $Z_{so} = Z_{s1} + \frac{3}{2N} Z_0 \times 100$	$Z_{so} = Z_{s1} + \frac{3(N-1)}{2N} Z_0$ $Z_{so} = Z_{s1} - \frac{3(N-1)}{2N} Z_0$ $Z_{so} = Z_{s1} + \frac{3}{2N} Z_0 \times 100$
<p>D-2</p> <p>STAR/STAR/DELTA, UNGROUNDED NEUTRAL.</p> <p>PARTS RATIOS SAME AS D-1</p>		SAME AS D-1	SAME AS D-1	$Z_0 = 3Z_T$ $Z_0 = Z_0$ $Z_0 = \infty$ $Z_0 \text{ AND } Z_0' \text{ ARE NOT TRANSFORMED}$	$N = 1+n$ $Z_0 = N^2 Z_0$ $Z_0 = \frac{Z_0}{N^2}$ $Z_0 = \infty$
<p>D-3</p> <p>DELTA/DELTA/STAR, SYMMETRICAL CASE. (SEE NOTE.)</p> <p>PARTS RATIOS</p> $U_2 = U$ $U_3 = \frac{1}{2} U + j \frac{\sqrt{3}}{2} U'$ $U_4 = \frac{1}{2} U + j \frac{\sqrt{3}}{2} U'$ <p>(VECTORIAL ADDITION)</p>		$N = \frac{2N}{N-1}$ $Z_{s1} = \frac{1}{2} (4Z_{ps} - Z_{st})$ $Z_{L1} = Z_{st}$	$Z_{s1} = \frac{1}{2} (4Z_{ps} - Z_{st})$ $Z_{L1} = \frac{1}{2} Z_{st}$	$Z_0 = \frac{1}{2} Z_{st}$ $Z_0 = \frac{1}{2} (4Z_{ps} - Z_{st}) + 3Z_0$ <p>NOTE: Z_0 AND Z_0' ARE NOT TRANSFORMED</p>	$Z_0 = \frac{1}{2} Z_{st}$ $Z_0 = \frac{1}{2} (4Z_{ps} - Z_{st}) + 3Z_0$ $Z_0 = \frac{1}{2} Z_{st} + \frac{3}{2} Z_0 \times 100$
<p>D-4</p> <p>DELTA/DELTA/STAR, GENERAL CASE.</p> <p>PARTS RATIOS SAME AS D-3</p> <p>NOTE: FOR SYMMETRICAL CASE $Z_{ps} = Z_{st}$ (IN OHMS)</p>		$N = \frac{2N}{N-1}$ $Z_{s1} = \frac{1}{2} (Z_{ps} - Z_{st})$ $Z_{s2} = \frac{1}{2} (2Z_{ps} + 2Z_{st} - Z_{st}) - Z_{st}$ $Z_{L1} = Z_{st} - Z_{st}$	$Z_{s1} = \frac{1}{2} (Z_{ps} - Z_{st})$ $Z_{s2} = \frac{1}{2} (2Z_{ps} + 2Z_{st} - Z_{st}) - Z_{st}$ $Z_{L1} = \frac{1}{2} Z_{st} - Z_{st}$	$N = \frac{2N}{N-1}$ $Z_{so} = \frac{1}{2} Z_{st} (Z_{ps} - Z_{st})$ $Z_{so} = \frac{1}{2} (2Z_{ps} + 2Z_{st} - Z_{st}) - Z_{st} - Z_{so}$ $Z_{so} = \frac{1}{2} Z_{st} - Z_{so}$ <p>NOTE: Z_0 AND Z_0' ARE NOT TRANSFORMED</p>	$Z_{so} = \frac{1}{2} Z_{st} (Z_{ps} - Z_{st})$ $Z_{so} = \frac{1}{2} (2Z_{ps} + 2Z_{st} - Z_{st}) - Z_{st} - Z_{so}$ $Z_{so} = \frac{1}{2} Z_{st} - Z_{so}$ <p>NOTE: Z_0 AND Z_0' ARE NOT TRANSFORMED</p>

TABLE 7 CONT'D—THREE-CIRCUIT TRANSFORMERS

DESCRIPTION	DIAGRAM OF CONNECTIONS	POSITIVE-SEQUENCE EQUIVALENT CIRCUIT		ZERO-SEQUENCE EQUIVALENT CIRCUIT	
		Expressed in Ohms	Expressed in Per Cent	Expressed in Ohms	Expressed in Per Cent
C-1 STAR/STAR/STAR SOLIDLY GROUND NEUTRALS		 $N' = n_1$ $N' = n_2$ $Z_{M1} = \frac{1}{3} [E_{ps} + 2Z_T - \frac{2Z_C}{N^2}]$ $Z_{M2} = \frac{1}{3} [E_{ps} + \frac{2Z_C}{N^2} - 2Z_T]$ $Z_{L1} = \frac{1}{3} [2Z_T + \frac{2Z_C}{N^2} - 2Z_C]$	 $Z_{M1} \% = \frac{1}{3} [E_{ps} \% + 2Z_T \% - \frac{2Z_C}{N^2} \%]$ $Z_{M2} \% = \frac{1}{3} [E_{ps} \% + \frac{2Z_C}{N^2} \% - 2Z_T \%]$ $Z_{L1} \% = \frac{1}{3} [2Z_T \% + \frac{2Z_C}{N^2} \% - 2Z_C \%]$	 $N' = n_1$ $N' = n_2$ $Z_{M0} = 2Z_{M1}$ $Z_{M2} = 2Z_{M1}$ $Z_{L0} = 2Z_{L1}$	 $Z_{M0} \% = 2Z_{M1} \%$ $Z_{M2} \% = 2Z_{M1} \%$ $Z_{L0} \% = 2Z_{L1} \%$
C-2 STAR/STAR/STAR IMPEDANCE GROUND NEUTRALS		SAME AS C-1	SAME AS C-1	 $N' = n_1$ $N' = n_2$ $Z_{M0} = 2Z_{M1} + 3Z_{CG} + \frac{3Z_C(N^2 - 1)}{N^2} Z_C$ $Z_{M2} = 2Z_{M1} + \frac{3Z_C}{N^2} - \frac{3Z_C(N^2 - 1)}{N^2} Z_C$ $Z_{L0} = 2Z_{L1} + \frac{3Z_C}{N^2} + \frac{3Z_C(N^2 - 1)}{N^2} Z_C$	 $Z_{M0} \% = 2Z_{M1} \% + \frac{3Z_{CG}}{Z_{CN}} + \frac{3Z_C(N^2 - 1)}{N^2} \frac{Z_C}{Z_{CN}} \times 100$ $Z_{M2} \% = 2Z_{M1} \% + \frac{3Z_C}{N^2} \% - \frac{3Z_C(N^2 - 1)}{N^2} \frac{Z_C}{Z_{CN}} \times 100$ $Z_{L0} \% = 2Z_{L1} \% + \frac{3Z_C}{N^2} \% + \frac{3Z_C(N^2 - 1)}{N^2} \frac{Z_C}{Z_{CN}} \times 100$
C-3 STAR/STAR/DELTA SOLIDLY GROUND NEUTRALS		 $N' = n_1$ $N' = \frac{n_2}{\sqrt{3}}$ $Z_{M1} = \frac{1}{3} [2Z_{ps} + 2Z_T - \frac{2Z_C}{N^2}]$ $Z_{M2} = \frac{1}{3} [2Z_{ps} + \frac{2Z_C}{N^2} - 2Z_T]$ $Z_{L1} = \frac{1}{3} [2Z_T + \frac{2Z_C}{N^2} - 2Z_C]$	 $Z_{M1} \% = \frac{1}{3} [2Z_{ps} \% + 2Z_T \% - \frac{2Z_C}{N^2} \%]$ $Z_{M2} \% = \frac{1}{3} [2Z_{ps} \% + \frac{2Z_C}{N^2} \% - 2Z_T \%]$ $Z_{L1} \% = \frac{1}{3} [2Z_T \% + \frac{2Z_C}{N^2} \% - 2Z_C \%]$	 $N' = n_1$ $Z_C = \infty$ $Z_{M0} = 2Z_{M1}$ $Z_{M2} = 2Z_{M1}$ $Z_{L0} = 2Z_{L1}$	 $Z_C \% = \infty$ $Z_{M0} \% = 2Z_{M1} \%$ $Z_{M2} \% = 2Z_{M1} \%$ $Z_{L0} \% = 2Z_{L1} \%$
C-4 STAR/STAR/DELTA IMPEDANCE GROUND NEUTRALS		SAME AS C-3	SAME AS C-3	 $N' = n_1$ $Z_C = \infty$ $Z_{M0} = 2Z_{M1} + 3Z_{CG} + 3 \frac{Z_C(N^2 - 1)}{N^2} Z_C$ $Z_{M2} = 2Z_{M1} + \frac{3Z_C}{N^2} + 3 \frac{Z_C(N^2 - 1)}{N^2} Z_C$ $Z_{L0} = 2Z_{L1} + 3 \frac{Z_C}{N^2}$	 $Z_C \% = \infty$ $Z_{M0} \% = 2Z_{M1} \% + 3Z_{CG} \% + 3 \frac{Z_C(N^2 - 1)}{N^2} \frac{Z_C}{Z_{CN}} \times 100$ $Z_{M2} \% = 2Z_{M1} \% + \frac{3Z_C}{N^2} \% + 3 \frac{Z_C(N^2 - 1)}{N^2} \frac{Z_C}{Z_{CN}} \times 100$ $Z_{L0} \% = 2Z_{L1} \% + 3 \frac{Z_C}{N^2} \% \times 100$
C-5 STAR/STAR/DELTA NEUTRALS CONNECTED BUT UNGROUNDED		SAME AS C-3	SAME AS C-3	 $N' = n_1$ $Z_C = \frac{1}{3} [2Z_T + 3Z_{CG} + \frac{3Z_C(N^2 - 1)}{N^2} Z_C]$	 $N' = n_1$ $Z_C \% = \frac{1}{3} [2Z_T \% + 3Z_{CG} \% + \frac{3Z_C(N^2 - 1)}{N^2} \frac{Z_C}{Z_{CN}} \times 100]$
C-6 DELTA/STAR/DELTA		 $N' = \sqrt{3} n_1$ $N' = n_2$ $Z_{M1} = \frac{1}{3} [2Z_{ps} + 2Z_T - \frac{2Z_C}{N^2}]$ $Z_{M2} = \frac{1}{3} [2Z_{ps} + \frac{2Z_C}{N^2} - 2Z_T]$ $Z_{L1} = \frac{1}{3} [2Z_T + \frac{2Z_C}{N^2} - 2Z_C]$	 $Z_{M1} \% = \frac{1}{3} [2Z_{ps} \% + 2Z_T \% - \frac{2Z_C}{N^2} \%]$ $Z_{M2} \% = \frac{1}{3} [2Z_{ps} \% + \frac{2Z_C}{N^2} \% - 2Z_T \%]$ $Z_{L1} \% = \frac{1}{3} [2Z_T \% + \frac{2Z_C}{N^2} \% - 2Z_C \%]$	 $N' = \sqrt{3} n_1$ $Z_C = \infty$ $Z_{M0} = 2Z_{M1}$ $Z_{M2} = 2Z_{M1} + \frac{3Z_C}{N^2}$ $Z_{L0} = 2Z_{L1}$	 $Z_C \% = \infty$ $Z_{M0} \% = 2Z_{M1} \%$ $Z_{M2} \% = 2Z_{M1} \% + \frac{3Z_C}{N^2} \%$ $Z_{L0} \% = 2Z_{L1} \%$
C-7 DELTA/DELTA/DELTA		 $N' = n_1$ $N' = n_2$ $Z_{M1} = \frac{1}{3} [2Z_{ps} + 2Z_T - \frac{2Z_C}{N^2}]$ $Z_{M2} = \frac{1}{3} [2Z_{ps} + \frac{2Z_C}{N^2} - 2Z_T]$ $Z_{L1} = \frac{1}{3} [2Z_T + \frac{2Z_C}{N^2} - 2Z_C]$	 $Z_{M1} \% = \frac{1}{3} [2Z_{ps} \% + 2Z_T \% - \frac{2Z_C}{N^2} \%]$ $Z_{M2} \% = \frac{1}{3} [2Z_{ps} \% + \frac{2Z_C}{N^2} \% - 2Z_T \%]$ $Z_{L1} \% = \frac{1}{3} [2Z_T \% + \frac{2Z_C}{N^2} \% - 2Z_C \%]$	 $N' = n_1$ $Z_C = \infty$ $Z_{M0} = 2Z_{M1}$ $Z_{M2} = 2Z_{M1}$ $Z_{L0} = 2Z_{L1}$	 $Z_C \% = \infty$ $Z_{M0} \% = 2Z_{M1} \%$ $Z_{M2} \% = 2Z_{M1} \%$ $Z_{L0} \% = 2Z_{L1} \%$
C-8 210-ZAG/STAR/DELTA SYMMETRICAL CASE SEE NOTE, C-11 PARTS RATIOS $\frac{U_1}{U_2} = \frac{U_3}{U_4} = \frac{U_5}{U_6}$		 $N' = \frac{n_1}{\sqrt{3}}$ $N' = \frac{n_2}{\sqrt{3}}$ $Z_{M1} = \frac{1}{3} [2Z_{ps} + 2Z_T + 2Z_C]$ $Z_{M2} = \frac{1}{3} [2Z_{ps} + 2Z_C + 2Z_T - 2Z_C]$ $Z_{L1} = \frac{1}{3} [2Z_T + 2Z_C + 2Z_C]$	 $Z_{M1} \% = \frac{1}{3} [2Z_{ps} \% + 2Z_T \% + 2Z_C \%]$ $Z_{M2} \% = \frac{1}{3} [2Z_{ps} \% + 2Z_C \% + 2Z_T \% - 2Z_C \%]$ $Z_{L1} \% = \frac{1}{3} [2Z_T \% + 2Z_C \% + 2Z_C \%]$	 $N' = \frac{n_1}{\sqrt{3}}$ $Z_C = \infty$ $Z_{M0} = 2Z_{M1} + 3Z_{CG}$ $Z_{M2} = 2Z_{M1} + 3Z_{CG}$ $Z_{L0} = 2Z_{L1} + 3Z_{CG}$	 $Z_C \% = \infty$ $Z_{M0} \% = 2Z_{M1} \% + 3Z_{CG} \% \times 100$ $Z_{M2} \% = 2Z_{M1} \% + 3Z_{CG} \% \times 100$ $Z_{L0} \% = 2Z_{L1} \% + 3Z_{CG} \% \times 100$
C-9 210-ZAG/STAR/DELTA GENERAL CASE FOR SYMMETRICAL CASE, SEE C-8) PARTS RATIOS SAME AS C-8		 $N' = \frac{n_1}{\sqrt{3}}$ $N' = \frac{n_2}{\sqrt{3}}$ $Z_{M1} = \frac{1}{3} [2Z_{ps} + 2Z_T + 2Z_C]$ $Z_{M2} = \frac{1}{3} [2Z_{ps} + 2Z_C + 2Z_T - 2Z_C]$ $Z_{L1} = \frac{1}{3} [2Z_T + 2Z_C + 2Z_C]$	 $Z_{M1} \% = \frac{1}{3} [2Z_{ps} \% + 2Z_T \% + 2Z_C \%]$ $Z_{M2} \% = \frac{1}{3} [2Z_{ps} \% + 2Z_C \% + 2Z_T \% - 2Z_C \%]$ $Z_{L1} \% = \frac{1}{3} [2Z_T \% + 2Z_C \% + 2Z_C \%]$	 $N' = \frac{n_1}{\sqrt{3}}$ $Z_C = \infty$ $Z_{M0} = 2Z_{M1} + 3Z_{CG} + 3Z_C$ $Z_{M2} = 2Z_{M1} + 3Z_{CG} + 3Z_C$ $Z_{L0} = 2Z_{L1} + 3Z_{CG} + 3Z_C$	 $Z_C \% = \infty$ $Z_{M0} \% = 2Z_{M1} \% + 3Z_{CG} \% + 3 \frac{Z_C}{N^2} \times 100$ $Z_{M2} \% = 2Z_{M1} \% + 3Z_{CG} \% + 3 \frac{Z_C}{N^2} \times 100$ $Z_{L0} \% = 2Z_{L1} \% + 3Z_{CG} \% + 3 \frac{Z_C}{N^2} \times 100$

TABLE 7 CONT'D—REGULATORS FOR VOLTAGE CONTROL

DESCRIPTION	DIAGRAM OF CONNECTIONS	POSITIVE-SEQUENCE EQUIVALENT CIRCUIT			
		Expressed in Ohms	Expressed in Per Cent	Expressed in Ohms	Expressed in Per Cent
E-1 TO E-6 STAR/STAR AUTOTRANSFORMER REGULATORS.	REFER TO CORRESPONDING AUTOTRANSFORMER. E-1 GROUND NEUTRAL, 3 PHASE CORE TYPE. SEE B-2. E-2 GROUND NEUTRAL, 3 PHASE CORE TYPE. SEE B-2. E-3 UNGROUND NEUTRAL. SEE B-3. E-4 TWO SERIES WINDINGS, GROUND NEUTRAL. SEE B-4. E-5 TWO SERIES WINDINGS, GROUND NEUTRAL, 3 PHASE CORE TYPE. SEE B-5. E-6 TWO SERIES WINDINGS, UNGROUND NEUTRAL. SEE B-6.				
E-7 STAR/STAR AUTO WITH DELTA TERTIARY, GROUND NEUTRAL. PARTS RATIOS $\frac{U_2}{U_1} = \frac{U_3}{U_4} = \frac{N-1}{N}$		 $N = 1 + \frac{N_2}{N_1}$ $Z_1 = \left(\frac{N-1}{N}\right)^2 Z_{20}$	 $Z_1 \% = \frac{N-1}{N} Z_{20} \%$	 $N = 1 + \frac{N_2}{N_1}$ $Z_{20} = \frac{1}{3} \left[\frac{Z_{20} + Z_{20} + Z_{20}}{3} + \frac{Z_{20}}{3} \times 100 \right]$ $Z_{L0} \% = \frac{1}{2} (Z_{20} \% + Z_{20} \% - Z_{20} \%)$ $Z_{H0} \% = \frac{1}{2} \left[\frac{Z_{20} + Z_{20} + Z_{20}}{3} + \frac{Z_{20}}{3} \times 100 \right]$ $Z_{0} \% = \frac{1}{2} \left[\frac{Z_{20} + Z_{20} + Z_{20}}{3} + \frac{Z_{20}}{3} \times 100 \right]$	 $N = 1 + \frac{N_2}{N_1}$ $Z_{0} \% = \frac{N-1}{N} Z_{20} \%$
E-8 STAR/STAR AUTO WITH DELTA TERTIARY, UNGROUND NEUTRAL. PARTS RATIOS SAME AS E-7		SAME AS E-7	SAME AS E-7	$Z_0 = Z_{20}$ I_0 AND E_0 ARE NOT TRANSFORMED.	$N = 1 + \frac{N_2}{N_1}$ $Z_0 \% = \frac{N-1}{N} Z_{20} \%$
E-9 STAR SERIES, STAR/STAR AUTO EXCITING, GROUND NEUTRAL. PARTS RATIOS $\frac{U_2}{U_1} = \frac{U_3}{U_4} = \frac{N-1}{N}$ $\frac{U_2}{U_1} = \frac{U_3}{U_4} = \frac{N-1}{N}$		$N = 1 + \frac{N_2}{N_1}$ $Z_1 = \frac{1}{3} [Z_{20} + (N-1)^2 Z_{20}]$ $Z_1' = N^2 Z_1 = Z_{20} + (N-1)^2 Z_{20}$	$Z_1 \% = \frac{N-1}{3} (Z_{20} \% + \frac{2}{3} Z_{20} \%)$ $Z_1' \% = Z_1 \%$	$N = 1 + \frac{N_2}{N_1}$ $Z_0 = \frac{1}{3} [Z_{20} + (N-1)^2 Z_{20} + 3Z_0]$ $Z_0' = N^2 Z_0 = Z_{20} + (N-1)^2 Z_{20} + 3Z_0$	$Z_0 \% = \frac{N-1}{3} (Z_{20} \% + \frac{2}{3} Z_{20} \%)$ $Z_0' \% = \frac{1}{3} [Z_{20} \% + \frac{2}{3} Z_{20} \% + 100]$ $Z_0 \% = Z_0 \%$
E-10 STAR SERIES, STAR/STAR AUTO EXCITING, GROUND NEUTRAL, (3 PHASE CORE TYPE) PARTS RATIOS SAME AS E-9		SAME AS E-9	SAME AS E-9	APPROXIMATE EXPRESSIONS $N = 1 + \frac{N_2}{N_1}$ $Z_{20} = \frac{1}{3} [Z_{20} + (N-1)^2 Z_{20} + 3Z_0]$ $Z_{L0} = \frac{1}{2} [Z_{20} + (N-1)^2 Z_{20}] (Z_{20} - \frac{1}{2} Z_{20})$ $Z_{H0} = \frac{1}{2} [Z_{20} + (N-1)^2 Z_{20}] (Z_{20} + \frac{1}{2} Z_{20})$ $Z_0 = \frac{1}{3} [Z_{20} + (N-1)^2 Z_{20} + 3Z_0]$	APPROXIMATE EXPRESSIONS $Z_{20} \% = \frac{1}{3} [Z_{20} \% + (N-1)^2 Z_{20} \% + 3Z_0 \%]$ $Z_{L0} \% = \frac{1}{2} [Z_{20} \% + (N-1)^2 Z_{20} \%] (Z_{20} \% - \frac{1}{2} Z_{20} \%)$ $Z_{H0} \% = \frac{1}{2} [Z_{20} \% + (N-1)^2 Z_{20} \%] (Z_{20} \% + \frac{1}{2} Z_{20} \%)$ $Z_0 \% = \frac{1}{3} [Z_{20} \% + (N-1)^2 Z_{20} \% + 3Z_0 \%]$
E-11 STAR SERIES, STAR/STAR AUTO EXCITING, UNGROUND NEUTRAL. PARTS RATIOS SAME AS E-9		SAME AS E-9	SAME AS E-9	APPROXIMATE EXPRESSION $Z_0 = \frac{1}{3} [Z_{20} + (N-1)^2 Z_{20} + 3Z_0]$ NOTE: Z_{20} AND Z_{20}' ARE ∞ EXCEPT FOR 3 PHASE CORE TYPE. $Z_0' = Z_0$ I_0 AND E_0 ARE NOT TRANSFORMED.	APPROXIMATE EXPRESSION $Z_0 \% = \frac{1}{3} [Z_{20} \% + (N-1)^2 Z_{20} \% + 3Z_0 \%]$ NOTE: Z_{20} AND Z_{20}' ARE ∞ EXCEPT FOR 3 PHASE CORE TYPE. $Z_0 \% = \frac{1}{3} Z_0 \%$
E-12 STAR SERIES, STAR/STAR AUTO EXCITING WITH DELTA TERTIARY, GROUND NEUTRAL. PARTS RATIOS $\frac{U_2}{U_1} = \frac{U_3}{U_4} = \frac{N-1}{N}$ $\frac{U_2}{U_1} = \frac{U_3}{U_4} = \frac{N-1}{N}$		SAME AS E-9	SAME AS E-9	$N = 1 + \frac{N_2}{N_1}$ $Z_{20} = \frac{1}{3} [Z_{20} + (N-1)^2 Z_{20} + 3Z_0]$ $Z_{L0} = \frac{1}{2} [Z_{20} + (N-1)^2 Z_{20}] (Z_{20} - \frac{1}{2} Z_{20})$ $Z_{H0} = \frac{1}{2} [Z_{20} + (N-1)^2 Z_{20}] (Z_{20} + \frac{1}{2} Z_{20})$ $Z_0 = \frac{1}{3} [Z_{20} + (N-1)^2 Z_{20} + 3Z_0]$	$N = 1 + \frac{N_2}{N_1}$ $Z_{20} \% = \frac{1}{3} [Z_{20} \% + (N-1)^2 Z_{20} \% + 3Z_0 \%]$ $Z_{L0} \% = \frac{1}{2} [Z_{20} \% + (N-1)^2 Z_{20} \%] (Z_{20} \% - \frac{1}{2} Z_{20} \%)$ $Z_{H0} \% = \frac{1}{2} [Z_{20} \% + (N-1)^2 Z_{20} \%] (Z_{20} \% + \frac{1}{2} Z_{20} \%)$ $Z_0 \% = \frac{1}{3} [Z_{20} \% + (N-1)^2 Z_{20} \% + 3Z_0 \%]$
E-13 STAR SERIES, STAR/STAR AUTO EXCITING WITH DELTA TERTIARY, UNGROUND NEUTRAL. PARTS RATIOS SAME AS E-12		SAME AS E-9	SAME AS E-9	$Z_0 = Z_{20} + (N-1)^2 Z_{20}$ $Z_0' = Z_0$ NOTE: Z_0 AND E_0 ARE NOT TRANSFORMED.	$N = 1 + \frac{N_2}{N_1}$ $Z_0 \% = \frac{1}{3} [Z_{20} \% + (N-1)^2 Z_{20} \% + 3Z_0 \%]$ $Z_0' \% = \frac{1}{3} [Z_{20} \% + (N-1)^2 Z_{20} \% + 3Z_0 \%]$
E-14 STAR SERIES, STAR/STAR EXCITING, GROUND NEUTRAL. PARTS RATIOS $\frac{U_2}{U_1} = \frac{U_3}{U_4} = \frac{N-1}{N}$ $\frac{U_2}{U_1} = \frac{U_3}{U_4} = \frac{N-1}{N}$		$N = 1 + \frac{N_2}{N_1}$ $Z_1 = \frac{1}{3} [Z_{20} + (N-1)^2 Z_{20}]$ $Z_1' = N^2 Z_1 = Z_{20} + (N-1)^2 Z_{20}$	$Z_1 \% = \frac{N-1}{3} (Z_{20} \% + Z_{20} \%)$ $Z_1' \% = Z_1 \%$	$N = 1 + \frac{N_2}{N_1}$ $Z_0 = \frac{1}{3} [Z_{20} + (N-1)^2 Z_{20} + 3Z_0]$ $Z_0' = N^2 Z_0 = Z_{20} + (N-1)^2 Z_{20} + 3Z_0$	$Z_0 \% = \frac{N-1}{3} (Z_{20} \% + Z_{20} \%)$ $Z_0' \% = \frac{1}{3} [Z_{20} \% + \frac{2}{3} Z_{20} \% + 100]$ $Z_0 \% = Z_0 \%$
E-15 STAR SERIES, STAR/STAR EXCITING, GROUND NEUTRAL, (3 PHASE CORE TYPE) PARTS RATIOS SAME AS E-14		SAME AS E-14	SAME AS E-14	APPROXIMATE EXPRESSIONS $N = 1 + \frac{N_2}{N_1}$ $Z_{20} = \frac{1}{3} [Z_{20} + (N-1)^2 Z_{20} + 3Z_0]$ $Z_{L0} = \frac{1}{2} [Z_{20} + (N-1)^2 Z_{20}] (Z_{20} - \frac{1}{2} Z_{20})$ $Z_{H0} = \frac{1}{2} [Z_{20} + (N-1)^2 Z_{20}] (Z_{20} + \frac{1}{2} Z_{20})$ $Z_0 = \frac{1}{3} [Z_{20} + (N-1)^2 Z_{20} + 3Z_0]$	APPROXIMATE EXPRESSIONS $Z_{20} \% = \frac{1}{3} [Z_{20} \% + (N-1)^2 Z_{20} \% + 3Z_0 \%]$ $Z_{L0} \% = \frac{1}{2} [Z_{20} \% + (N-1)^2 Z_{20} \%] (Z_{20} \% - \frac{1}{2} Z_{20} \%)$ $Z_{H0} \% = \frac{1}{2} [Z_{20} \% + (N-1)^2 Z_{20} \%] (Z_{20} \% + \frac{1}{2} Z_{20} \%)$ $Z_0 \% = \frac{1}{3} [Z_{20} \% + (N-1)^2 Z_{20} \% + 3Z_0 \%]$

TABLE 7 CONT'D—REGULATORS FOR PHASE-ANGLE CONTROL

DESCRIPTION	DIAGRAM OF CONNECTIONS	POSITIVE-SEQUENCE EQUIVALENT CIRCUIT		ZERO-SEQUENCE EQUIVALENT CIRCUIT	
		Expressed in Ohms	Expressed in Per Cent	Expressed in Ohms	Expressed in Per Cent
F-1 DELTA SERIES, STAR/STAR AUTO EXCITING, GROUNDED OR UNGROUNDED NEUTRAL. PARTS RATIOS $\frac{U_V}{U_C} = \frac{\sqrt{3} n_2}{N(1+n_1)} \sin \alpha$ $\frac{U_W}{U_C} = \frac{n_1}{1+n_1} \sin \alpha$		 $N = \sqrt{1 + \frac{3n_2^2}{(1+n_1)^2}} = \sec \alpha$ $\alpha = \tan^{-1} \frac{\sqrt{3} n_2}{(1+n_1)}$ $Z_1 = \frac{1}{N^2} [Z_{10} + n_1^2 (n_2^2 - 1) Z_{20}]$ $Z_2 = Z_{20} + n_2^2 (n_2^2 - 1) Z_{30}$	$\alpha = \tan^{-1} \frac{\sqrt{3} n_2}{(1+n_1)}$ $Z_1 \% = \sin \alpha (Z_{10} \% + \frac{n_1}{1+n_1} Z_{20} \%)$ $Z_2 \% = Z_{20} \%$	 $Z_0 = Z_{00}$ $Z_0' = Z_0$ I_0 AND E_0 ARE NOT TRANSFORMED.	$N = \sqrt{1 + \frac{3n_2^2}{(1+n_1)^2}} = \sec \alpha$ $Z_0 \% = \sec \alpha \tan \alpha Z_{00} \% = n_2^2 \sin \alpha Z_{00} \%$ $Z_0' \% = \frac{1}{N^2} Z_0 \% = \sin \alpha Z_{00} \%$
F-2 DELTA SERIES, STAR/STAR AUTO EXCITING, GROUNDED NEUTRAL, (3 PHASE CORE TYPE EXCITING TRANSFORMER) (IF UNGROUNDED, SAME AS F-1) PARTS RATIOS SAME AS F-1		SAME AS F-1	SAME AS F-1	 $N = \sqrt{1 + \frac{3n_2^2}{(1+n_1)^2}} = \sec \alpha$ APPROXIMATE EXPRESSIONS $Z_{100} = \frac{1}{N^2} [(1+n_1)^2 Z_{10} - n_1 Z_{20}] + \frac{1}{N^2} Z_0$ $Z_{20} = (n_2 - 1) Z_{100}$ $Z_{30} = \frac{1}{N^2} Z_{100} - \frac{(n_2-1)}{N} Z_{200}$	APPROXIMATE EXPRESSIONS $Z_{100} \% = \cot \alpha \left[\frac{(1+n_1)^2}{1+n_1} Z_{10} \% - Z_{20} \% \right] + \frac{3Z_0}{N^2} \% \times 100$ $Z_{20} \% = (n_2 - 1) Z_{100} \%$ $Z_{30} \% = \sin \alpha Z_{100} \% - \frac{(n_2-1)}{N} Z_{200} \%$
F-3 DELTA SERIES, STAR/STAR AUTO EXCITING WITH DELTA TERTIARY, GROUNDED NEUTRAL (IF UNGROUNDED, SAME AS F-2) PARTS RATIOS $\frac{U_V}{U_C} = \frac{\sqrt{3} n_2}{N(1+n_1)} \sin \alpha$ $\frac{U_W}{U_C} = \frac{n_1}{1+n_1} \sin \alpha$		SAME AS F-1	SAME AS F-1	 $N = \sqrt{1 + \frac{3n_2^2}{(1+n_1)^2}} = \sec \alpha$ $Z_{100} = \frac{1}{N^2} [(1+n_1)^2 Z_{10} - n_1 Z_{20} + \frac{1}{N^2} Z_{30}] + \frac{1}{N^2} Z_0$ $Z_{20} = (n_2 - 1) Z_{100}$ $Z_{30} = \frac{1}{N^2} Z_{100} - \frac{(n_2-1)}{N} Z_{200}$	$Z_{100} \% = \cot \alpha \left(\frac{1}{N^2} Z_{10} \% - \frac{1}{N^2} Z_{20} \% + Z_{30} \% \right) + \frac{3Z_0}{N^2} \% \times 100$ $Z_{20} \% = (n_2 - 1) Z_{100} \%$ $Z_{30} \% = \sin \alpha Z_{100} \% - \frac{(n_2-1)}{N} Z_{200} \%$
F-4 DELTA SERIES, STAR/STAR EXCITING, GROUNDED OR UNGROUNDED NEUTRAL. PARTS RATIOS $\frac{U_V}{U_C} = \frac{\sqrt{3} n_2}{N}$ $\frac{U_W}{U_C} = \frac{n_1}{N}$ $= \sin \alpha$		$N = \sqrt{1 + 3n_2^2} = \sec \alpha$ $\alpha = \tan^{-1} \sqrt{3} n_2$ $Z_1 = \frac{1}{N^2} (Z_{10} + 3n_2^2 n_1^2 Z_{20})$ $Z_2 = n_2^2 Z_1 = Z_{20} + 3n_2^2 n_1^2 Z_{30}$	$\alpha = \tan^{-1} \sqrt{3} n_2$ $Z_1 \% = \sin \alpha (Z_{10} \% + 3n_1^2 Z_{20} \%)$ $Z_2 \% = Z_1 \%$	$Z_0 = Z_{00}$ $Z_0' = Z_0 + Z_{00}$ I_0 AND E_0 ARE NOT TRANSFORMED.	$N = \sqrt{1 + 3n_2^2} = \sec \alpha$ $Z_0 \% = \sec \alpha \tan \alpha Z_{00} \% = n_2^2 Z_{00} \%$ $Z_0' \% = \frac{1}{N^2} Z_0 \% = \sin \alpha Z_{00} \%$
F-5 DELTA SERIES, STAR/STAR EXCITING, GROUNDED NEUTRAL, (3 PHASE CORE TYPE EXCITING TRANSFORMER) (IF UNGROUNDED, SAME AS F-4) PARTS RATIOS SAME AS F-4		SAME AS F-4	SAME AS F-4	 $N = \sqrt{1 + 3n_2^2} = \sec \alpha$ $Z_{100} = \frac{1}{N^2} Z_{10} + \frac{1}{N^2} Z_0$ $Z_{20} = (n_2 - 1) Z_{100}$ $Z_{30} = \frac{1}{N^2} Z_{100} - \frac{(n_2-1)}{N} Z_{200}$	$Z_{100} \% = \cot \alpha Z_{10} \% + \frac{3Z_0}{N^2} \% \times 100$ $Z_{20} \% = (n_2 - 1) Z_{100} \%$ $Z_{30} \% = \sin \alpha Z_{100} \% - \frac{(n_2-1)}{N} Z_{200} \%$
F-6 DELTA SERIES, STAR/STAR EXCITING WITH DELTA TERTIARY, GROUNDED NEUTRAL, (IF UNGROUNDED, SAME AS F-4) PARTS RATIOS $\frac{U_V}{U_C} = \frac{\sqrt{3} n_2}{N}$ $\frac{U_W}{U_C} = \frac{n_1}{N}$ $= \sin \alpha$		SAME AS F-4	SAME AS F-4	 $N = \sqrt{1 + 3n_2^2} = \sec \alpha$ $Z_{100} = \frac{1}{N^2} Z_{10} + \frac{1}{N^2} Z_0$ $Z_{20} = (n_2 - 1) Z_{100}$ $Z_{30} = \frac{1}{N^2} Z_{100} - \frac{(n_2-1)}{N} Z_{200}$	$Z_{100} \% = \cot \alpha Z_{10} \% + \frac{3Z_0}{N^2} \% \times 100$ $Z_{20} \% = (n_2 - 1) Z_{100} \%$ $Z_{30} \% = \sin \alpha Z_{100} \% - \frac{(n_2-1)}{N} Z_{200} \%$
F-7 DELTA EXCITED SERIES. PARTS RATIOS $\frac{U_V}{U_C} = \frac{\sqrt{3} n_2}{N}$ $\frac{U_W}{U_C} = \frac{n_1}{N}$ $= \sin \alpha$		$N = \sqrt{1 + 3n_2^2} = \sec \alpha = \frac{1}{\cos \alpha}$ $\alpha = \tan^{-1} \sqrt{3} n_2$ $Z_1 = \frac{Z_{10}}{N^2}$ $Z_2 = n_2^2 Z_1 = Z_{20}$	$\alpha = \tan^{-1} \sqrt{3} n_2$ $Z_1 \% = \frac{1}{N^2} Z_{10} \% = \sin \alpha Z_{10} \%$ $Z_2 \% = Z_1 \%$	$Z_0 = Z_{00}$ $Z_0' = Z_0 + Z_{00}$ I_0 AND E_0 ARE NOT TRANSFORMED.	$N = \sqrt{1 + 3n_2^2} = \sec \alpha$ $Z_0 \% = \sin \alpha Z_{00} \% = \sec \alpha \tan \alpha Z_{00} \%$ $Z_0' \% = \frac{Z_0}{N^2} \% = \sin \alpha Z_{00} \%$
F-8 STAR SERIES, DELTA/STAR EXCITING, GROUNDED OR UNGROUNDED NEUTRAL. PARTS RATIOS $\frac{U_V}{U_C} = \frac{U_V}{U_C} = \frac{\sqrt{3} n_2}{N}$ $\frac{U_W}{U_C} = \frac{n_1}{N}$ $= \sin \alpha$		$N = \sqrt{1 + 3n_2^2} = \sec \alpha$ $\alpha = \tan^{-1} \sqrt{3} n_2$ $Z_1 = \frac{1}{N^2} (Z_{10} + n_1^2 n_2^2 Z_{20})$ $Z_2 = n_2^2 Z_1 = Z_{20} + n_1^2 n_2^2 Z_{30}$	$Z_1 \% = \sin \alpha (Z_{10} \% + Z_{20} \%)$ $Z_2 \% = Z_1 \%$	$Z_0 = Z_{00} + n_1^2 n_2^2 Z_{30}$ $Z_0' = Z_0$ I_0 AND E_0 ARE NOT TRANSFORMED.	$Z_0 \% = \sec \alpha \tan \alpha (Z_{10} \% + Z_{20} \%)$ $Z_0' \% = \frac{1}{N^2} Z_0 \% = Z_1 \%$

TABLE 7 CONT'D—REGULATORS FOR VOLTAGE AND PHASE-ANGLE CONTROL

DESCRIPTION	DIAGRAM OF CONNECTIONS	POSITIVE-SEQUENCE EQUIVALENT CIRCUIT		ZERO-SEQUENCE EQUIVALENT CIRCUIT	
		Expressed in Ohms	Expressed in Per Cent	Expressed in Ohms	Expressed in Per Cent
G-1 INDEPENDENT SERIES STAR/INDEPENDENT/ STAR EXCITING GROUNDED NEUTRAL					
PARTS RATIOS $\frac{U_1}{U_2} = \frac{N_1}{N_2}$ $\frac{U_1}{U_0} = \frac{N_1}{N_0}$ $\frac{U_2}{U_0} = \frac{N_2}{N_0}$ $\frac{U_1}{U_2} = \frac{N_1}{N_2}$ $\frac{U_1}{U_0} = \frac{N_1}{N_0}$ $\frac{U_2}{U_0} = \frac{N_2}{N_0}$		$N = \sqrt{(1+n_1n_2)^2 + 3n_1^2n_2^2}$ $\alpha = \tan^{-1} \frac{3n_1n_2}{1+n_1n_2}$ $Z_1 = \frac{1}{N} [Z_{2w} + n_1^2 Z_{2s} + 3n_1^2 n_2^2 Z_{2t}]$	$Z_1 \% = \frac{100}{N} \sqrt{(1+n_1n_2)^2 + 3n_1^2n_2^2} [(n_1^2 + 3n_2^2) Z_{2w} \% + n_1^2 Z_{2s} \% + 3n_1^2 n_2^2 Z_{2t} \%]$	$N = \sqrt{(1+n_1n_2)^2 + 3n_1^2n_2^2}$ $Z_0 = \frac{1}{N} [Z_{2w} + n_1^2 Z_{2s} + 3n_1^2 n_2^2 Z_{2t}]$ ZERO-SEQUENCE RATIO DIFFERS FROM POSITIVE-SEQUENCE RATIO	$N = \frac{100}{N} \sqrt{(1+n_1n_2)^2 + 3n_1^2n_2^2} [(n_1^2 + 3n_2^2) Z_{2w} \% + n_1^2 Z_{2s} \% + 3n_1^2 n_2^2 Z_{2t} \%]$
G-2 INDEPENDENT SERIES STAR/INDEPENDENT/ STAR EXCITING GROUNDED NEUTRAL 3 PHASE CORE TYPE		SAME AS G-1	SAME AS G-1		APPROXIMATE EXPRESSIONS $Z_{2w} \% = \frac{100}{N} [Z_{2w} + n_1^2 Z_{2s} + 3n_1^2 n_2^2 Z_{2t}]$ $Z_{2s} \% = \frac{100}{N} [Z_{2s} + n_1^2 Z_{2w} + 3n_1^2 n_2^2 Z_{2t}]$ $Z_{2t} \% = \frac{100}{N} [Z_{2t} + n_1^2 Z_{2w} + 3n_1^2 n_2^2 Z_{2s}]$
G-3 INDEPENDENT SERIES STAR/INDEPENDENT/ STAR EXCITING UNGROUNDED NEUTRAL		SAME AS G-1	SAME AS G-1		APPROXIMATE EXPRESSIONS $Z_{2w} \% = \frac{100}{N} [Z_{2w} + n_1^2 Z_{2s} + 3n_1^2 n_2^2 Z_{2t}]$ NOTE: Z_{2s} AND Z_{2t} ARE ∞ EXCEPT FOR 3 PHASE CORE TYPE. Z_0 AND E_0 ARE NOT TRANSFORMED.
G-4 INDEPENDENT SERIES DELTA/STAR/ INDEPENDENT EXCITING					
PARTS RATIOS $\frac{U_1}{U_2} = \frac{N_1}{N_2}$ $\frac{U_1}{U_0} = \frac{N_1}{N_0}$ $\frac{U_2}{U_0} = \frac{N_2}{N_0}$ $\frac{U_1}{U_2} = \frac{N_1}{N_2}$ $\frac{U_1}{U_0} = \frac{N_1}{N_0}$ $\frac{U_2}{U_0} = \frac{N_2}{N_0}$		$N = \sqrt{(1+n_1n_2)^2 + 3n_1^2n_2^2}$ $\alpha = \tan^{-1} \frac{3n_1n_2}{1+n_1n_2}$ $Z_1 = \frac{1}{N} [Z_{2w} + n_1^2 Z_{2s} + 3n_1^2 n_2^2 Z_{2t}]$ $Z_1 = N^2 Z_1 = Z_{2w} + n_1^2 Z_{2s} + 3n_1^2 n_2^2 Z_{2t}$	$Z_1 \% = \frac{100}{N} \sqrt{(1+n_1n_2)^2 + 3n_1^2n_2^2} [Z_{2w} \% + n_1^2 Z_{2s} \% + 3n_1^2 n_2^2 Z_{2t} \%]$	$N = \sqrt{(1+n_1n_2)^2 + 3n_1^2n_2^2}$ $Z_0 = \frac{1}{N} [Z_{2w} + n_1^2 Z_{2s} + 3n_1^2 n_2^2 Z_{2t}]$ $Z_0 = Z_0$ Z_0 AND E_0 ARE NOT TRANSFORMED	$N = \sqrt{(1+n_1n_2)^2 + 3n_1^2n_2^2}$ $Z_0 \% = \frac{100}{N} [Z_{2w} \% + n_1^2 Z_{2s} \% + 3n_1^2 n_2^2 Z_{2t} \%]$
G-5 STAR AND DELTA SERIES, STAR/STAR/STAR EXCITING, GROUNDED NEUTRAL 3 PHASE CORE TYPE					
PARTS RATIOS $\frac{U_1}{U_2} = \frac{N_1}{N_2}$ $\frac{U_1}{U_0} = \frac{N_1}{N_0}$ $\frac{U_2}{U_0} = \frac{N_2}{N_0}$ $\frac{U_1}{U_2} = \frac{N_1}{N_2}$ $\frac{U_1}{U_0} = \frac{N_1}{N_0}$ $\frac{U_2}{U_0} = \frac{N_2}{N_0}$		$N = \sqrt{(1+n_1n_2)^2 + 3n_1^2n_2^2}$ $\alpha = \tan^{-1} \frac{3n_1n_2}{1+n_1n_2}$ $Z_1 = \frac{1}{N} [Z_{2w} + n_1^2 Z_{2s} + 3n_1^2 n_2^2 Z_{2t}]$	$Z_1 \% = \frac{100}{N} \sqrt{(1+n_1n_2)^2 + 3n_1^2n_2^2} [Z_{2w} \% + n_1^2 Z_{2s} \% + 3n_1^2 n_2^2 Z_{2t} \%]$	APPROXIMATE EXPRESSIONS $Z_{2w} \% = \frac{100}{N} [Z_{2w} + n_1^2 Z_{2s} + 3n_1^2 n_2^2 Z_{2t}]$ $Z_{2s} \% = \frac{100}{N} [Z_{2s} + n_1^2 Z_{2w} + 3n_1^2 n_2^2 Z_{2t}]$ $Z_{2t} \% = \frac{100}{N} [Z_{2t} + n_1^2 Z_{2w} + 3n_1^2 n_2^2 Z_{2s}]$	$N = \sqrt{(1+n_1n_2)^2 + 3n_1^2n_2^2}$ $Z_0 \% = \frac{100}{N} [Z_{2w} \% + n_1^2 Z_{2s} \% + 3n_1^2 n_2^2 Z_{2t} \%]$
G-6 STAR AND DELTA SERIES, DELTA/STAR/STAR AUTO EXCITING.					
PARTS RATIOS $\frac{U_1}{U_2} = \frac{N_1}{N_2}$ $\frac{U_1}{U_0} = \frac{N_1}{N_0}$ $\frac{U_2}{U_0} = \frac{N_2}{N_0}$ $\frac{U_1}{U_2} = \frac{N_1}{N_2}$ $\frac{U_1}{U_0} = \frac{N_1}{N_0}$ $\frac{U_2}{U_0} = \frac{N_2}{N_0}$		$N = \sqrt{(1+n_1n_2)^2 + 3n_1^2n_2^2}$ $\alpha = \tan^{-1} \frac{3n_1n_2}{1+n_1n_2}$ $Z_1 = \frac{1}{N} [Z_{2w} + n_1^2 Z_{2s} + 3n_1^2 n_2^2 Z_{2t}]$	$Z_1 \% = \frac{100}{N} \sqrt{(1+n_1n_2)^2 + 3n_1^2n_2^2} [Z_{2w} \% + n_1^2 Z_{2s} \% + 3n_1^2 n_2^2 Z_{2t} \%]$	$Z_0 = Z_{2w} + Z_{2s} + n_1^2 Z_{2t}$ $Z_0 = Z_0$ Z_0 AND E_0 ARE NOT TRANSFORMED	$N = \sqrt{(1+n_1n_2)^2 + 3n_1^2n_2^2}$ $Z_0 \% = \frac{100}{N} [Z_{2w} \% + Z_{2s} \% + n_1^2 Z_{2t} \%]$

TABLE 9—TRIGONOMETRIC FUNCTIONS

Angle in degrees	Name of function	Value of function for each tenth of a degree										Angle in degrees	Name of function	Value of function for each tenth of a degree									
		0.0	0.1	0.2	0.3	0.4	0.5	0.6	0.7	0.8	0.9			0.0	0.1	0.2	0.3	0.4	0.5	0.6	0.7	0.8	0.9
0	sin	0.0000	0.0017	0.0035	0.0052	0.0070	0.0087	0.0105	0.0122	0.0140	0.0157	25	sin	0.4226	0.4242	0.4258	0.4274	0.4289	0.4305	0.4321	0.4337	0.4352	0.4368
	cos	1.0000	0.9998	0.9996	0.9993	0.9990	0.9987	0.9984	0.9981	0.9978	0.9975		cos	0.9063	0.9056	0.9048	0.9041	0.9033	0.9026	0.9018	0.9011	0.9003	0.8996
	tan	0.0000	0.0017	0.0035	0.0052	0.0070	0.0087	0.0105	0.0122	0.0140	0.0157		tan	0.4663	0.4684	0.4706	0.4727	0.4748	0.4770	0.4791	0.4813	0.4834	0.4856
1	sin	0.0175	0.0192	0.0209	0.0227	0.0244	0.0262	0.0279	0.0297	0.0314	0.0332	26	sin	0.4384	0.4399	0.4415	0.4431	0.4446	0.4462	0.4478	0.4493	0.4509	0.4524
	cos	0.9998	0.9998	0.9998	0.9997	0.9997	0.9997	0.9996	0.9996	0.9995	0.9995		cos	0.8988	0.8980	0.8973	0.8965	0.8957	0.8949	0.8942	0.8934	0.8926	0.8918
	tan	0.0175	0.0192	0.0209	0.0227	0.0244	0.0262	0.0279	0.0297	0.0314	0.0332		tan	0.4877	0.4899	0.4921	0.4942	0.4964	0.4986	0.5008	0.5029	0.5051	0.5073
2	sin	0.0349	0.0366	0.0384	0.0401	0.0419	0.0436	0.0454	0.0471	0.0488	0.0506	27	sin	0.4540	0.4555	0.4571	0.4586	0.4602	0.4617	0.4633	0.4648	0.4664	0.4679
	cos	0.9994	0.9993	0.9992	0.9991	0.9990	0.9989	0.9988	0.9987	0.9986	0.9985		cos	0.8910	0.8902	0.8894	0.8886	0.8878	0.8870	0.8862	0.8854	0.8846	0.8838
	tan	0.0349	0.0367	0.0384	0.0402	0.0419	0.0437	0.0454	0.0472	0.0489	0.0507		tan	0.5095	0.5117	0.5139	0.5161	0.5184	0.5206	0.5228	0.5250	0.5272	0.5295
3	sin	0.0523	0.0541	0.0558	0.0576	0.0593	0.0610	0.0628	0.0645	0.0663	0.0680	28	sin	0.4695	0.4710	0.4726	0.4741	0.4756	0.4772	0.4787	0.4802	0.4818	0.4833
	cos	0.9986	0.9985	0.9984	0.9983	0.9982	0.9981	0.9980	0.9979	0.9978	0.9977		cos	0.8829	0.8821	0.8813	0.8805	0.8797	0.8788	0.8780	0.8771	0.8763	0.8755
	tan	0.0524	0.0542	0.0559	0.0577	0.0594	0.0612	0.0629	0.0647	0.0664	0.0682		tan	0.5317	0.5340	0.5362	0.5384	0.5407	0.5430	0.5452	0.5475	0.5498	0.5520
4	sin	0.0698	0.0715	0.0732	0.0750	0.0767	0.0785	0.0802	0.0819	0.0837	0.0854	29	sin	0.4848	0.4863	0.4879	0.4894	0.4909	0.4924	0.4939	0.4955	0.4970	0.4985
	cos	0.9976	0.9974	0.9973	0.9972	0.9971	0.9969	0.9968	0.9966	0.9965	0.9963		cos	0.8746	0.8738	0.8729	0.8721	0.8712	0.8704	0.8695	0.8686	0.8678	0.8669
	tan	0.0699	0.0717	0.0734	0.0752	0.0769	0.0787	0.0805	0.0822	0.0840	0.0857		tan	0.5543	0.5566	0.5589	0.5612	0.5635	0.5658	0.5681	0.5704	0.5727	0.5750
5	sin	0.0872	0.0889	0.0906	0.0924	0.0941	0.0958	0.0976	0.0993	0.1011	0.1028	30	sin	0.5000	0.5015	0.5030	0.5045	0.5060	0.5075	0.5090	0.5105	0.5120	0.5135
	cos	0.9962	0.9960	0.9959	0.9957	0.9956	0.9954	0.9952	0.9951	0.9949	0.9947		cos	0.8660	0.8652	0.8643	0.8634	0.8625	0.8616	0.8607	0.8598	0.8590	0.8581
	tan	0.0875	0.0892	0.0910	0.0928	0.0945	0.0963	0.0981	0.0998	0.1016	0.1033		tan	0.5774	0.5797	0.5820	0.5844	0.5867	0.5890	0.5914	0.5938	0.5961	0.5985
6	sin	0.1045	0.1063	0.1080	0.1097	0.1115	0.1132	0.1149	0.1167	0.1184	0.1201	31	sin	0.5150	0.5165	0.5180	0.5195	0.5210	0.5225	0.5240	0.5255	0.5270	0.5284
	cos	0.9945	0.9943	0.9942	0.9940	0.9938	0.9936	0.9934	0.9932	0.9930	0.9928		cos	0.8572	0.8563	0.8554	0.8545	0.8536	0.8526	0.8517	0.8508	0.8499	0.8490
	tan	0.1051	0.1069	0.1086	0.1104	0.1122	0.1139	0.1157	0.1175	0.1192	0.1210		tan	0.6009	0.6032	0.6056	0.6080	0.6104	0.6128	0.6152	0.6176	0.6200	0.6224
7	sin	0.1219	0.1236	0.1253	0.1271	0.1288	0.1305	0.1323	0.1340	0.1357	0.1374	32	sin	0.5299	0.5314	0.5329	0.5344	0.5358	0.5373	0.5388	0.5402	0.5417	0.5432
	cos	0.9925	0.9923	0.9921	0.9919	0.9917	0.9914	0.9912	0.9910	0.9907	0.9905		cos	0.8480	0.8471	0.8462	0.8453	0.8443	0.8434	0.8425	0.8415	0.8406	0.8396
	tan	0.1228	0.1246	0.1263	0.1281	0.1299	0.1317	0.1334	0.1352	0.1370	0.1388		tan	0.6249	0.6273	0.6297	0.6322	0.6346	0.6371	0.6395	0.6420	0.6445	0.6469
8	sin	0.1392	0.1409	0.1426	0.1444	0.1461	0.1478	0.1495	0.1513	0.1530	0.1547	33	sin	0.5446	0.5461	0.5476	0.5490	0.5505	0.5519	0.5534	0.5548	0.5563	0.5577
	cos	0.9903	0.9900	0.9898	0.9895	0.9893	0.9890	0.9888	0.9885	0.9882	0.9880		cos	0.8387	0.8377	0.8368	0.8358	0.8348	0.8339	0.8329	0.8320	0.8310	0.8300
	tan	0.1405	0.1423	0.1441	0.1459	0.1477	0.1495	0.1512	0.1530	0.1548	0.1566		tan	0.6494	0.6519	0.6544	0.6569	0.6594	0.6619	0.6644	0.6669	0.6694	0.6720
9	sin	0.1564	0.1582	0.1599	0.1616	0.1633	0.1650	0.1668	0.1685	0.1702	0.1719	34	sin	0.5592	0.5606	0.5621	0.5635	0.5650	0.5664	0.5678	0.5693	0.5707	0.5721
	cos	0.9877	0.9874	0.9871	0.9868	0.9866	0.9863	0.9860	0.9857	0.9854	0.9851		cos	0.8290	0.8281	0.8271	0.8261	0.8251	0.8241	0.8231	0.8221	0.8211	0.8202
	tan	0.1584	0.1602	0.1620	0.1638	0.1655	0.1673	0.1691	0.1709	0.1727	0.1745		tan	0.6745	0.6771	0.6796	0.6822	0.6847	0.6873	0.6899	0.6924	0.6950	0.6976
10	sin	0.1736	0.1754	0.1771	0.1788	0.1805	0.1822	0.1840	0.1857	0.1874	0.1891	35	sin	0.5736	0.5750	0.5764	0.5779	0.5793	0.5807	0.5821	0.5835	0.5850	0.5864
	cos	0.9848	0.9845	0.9842	0.9839	0.9836	0.9833	0.9829	0.9826	0.9823	0.9820		cos	0.8192	0.8181	0.8171	0.8161	0.8151	0.8141	0.8131	0.8121	0.8111	0.8100
	tan	0.1763	0.1781	0.1799	0.1817	0.1835	0.1853	0.1871	0.1890	0.1908	0.1926		tan	0.7002	0.7028	0.7054	0.7080	0.7107	0.7133	0.7159	0.7186	0.7212	0.7239
11	sin	0.1908	0.1925	0.1942	0.1959	0.1977	0.1994	0.2011	0.2028	0.2045	0.2062	36	sin	0.5878	0.5892	0.5906	0.5920	0.5934	0.5948	0.5962	0.5976	0.5990	0.6004
	cos	0.9816	0.9813	0.9810	0.9806	0.9803	0.9800	0.9797	0.9794	0.9791	0.9788		cos	0.8097	0.8086	0.8076	0.8065	0.8054	0.8043	0.8032	0.8021	0.8010	0.7999
	tan	0.1944	0.1962	0.1980	0.1998	0.2016	0.2035	0.2053	0.2071	0.2089	0.2107		tan	0.7265	0.7292	0.7319	0.7346	0.7373	0.7400	0.7427	0.7454	0.7481	0.7508
12	sin	0.2079	0.2096	0.2113	0.2130	0.2147	0.2164	0.2181	0.2198	0.2215	0.2233	37	sin	0.6018	0.6032	0.6046	0.6060	0.6074	0.6088	0.6101	0.6115	0.6129	0.6143
	cos	0.9781	0.9778	0.9774	0.9770	0.9767	0.9763	0.9759	0.9755	0.9751	0.9748		cos	0.7986	0.7976	0.7965	0.7955	0.7944	0.7934	0.7923	0.7912	0.7902	0.7891
	tan	0.2126	0.2144	0.2162	0.2180	0.2199	0.2217	0.2235	0.2254	0.2272	0.2290		tan	0.7536	0.7563	0.7590	0.7618	0.7646	0.7673	0.7701	0.7729	0.7757	0.7785
13	sin	0.2250	0.2267	0.2284	0.2300	0.2317	0.2334	0.2351	0.2368	0.2385	0.2402	38	sin	0.6157	0.6170	0.6184	0.6198	0.6211	0.6225	0.6239	0.6252	0.6266	0.6280
	cos	0.9744	0.9740	0.9736	0.9732	0.9728	0.9724	0.9720	0.9715	0.9711	0.9707		cos	0.7890	0.7889	0.7889	0.7888	0.7887	0.7886	0.7885	0.7884	0.7883	0.7882
	tan	0.2309	0.2327	0.2345	0.2364	0.2382	0.2401	0.2419	0.2438	0.2456	0.2475		tan	0.7813	0.7841	0.7869	0.7898	0.7926	0.7954	0.7983	0.8012	0.8040	0.8069
14	sin	0.2419	0.2436	0.2453	0.2470	0.2487	0.2504	0.2521	0.2538	0.2554	0.2571	39	sin	0.6293	0.6307	0.6320	0.6334	0.6347	0.6361	0.6374	0.6388	0.6401	0.6414
	cos	0.9703	0.9699	0.9694	0.9689	0.9684	0.9681	0.9677	0.9673	0.9668	0.9663		cos	0.7771	0.7760	0.7749	0.7738	0.7727	0.7716	0.7705	0.7694	0.7683	0.7672
	tan	0.2493	0.2512	0.2530	0.2549	0.2568	0.2586	0.2605	0.2623	0.2642	0.2661		tan	0.8068	0.8127	0.8156	0.8185	0.8214	0.8243	0.8273	0.8302	0.8332	0.8361
15	sin	0.2588	0.2605	0.2622	0.2639	0.2656	0.2672	0.2689	0.2706	0.2723	0.2740	40	sin	0.6428	0.6441	0.6455	0.6468	0.6481	0.6494	0.6508	0.6521	0.6534	0.6547
	cos	0.9659	0.9655	0.9650	0.9646	0.9641	0.9636	0.9632	0.9627	0.9622	0.9617		cos	0.7600	0.7609	0.7638	0.7627	0.7615	0.7604	0.7593	0.7581	0.7570	0.7559
	tan	0.2679	0.2698	0.2717	0.2736	0.2754	0.2773	0.2792	0.2811	0.2830	0.2849		tan	0.8391	0.8421	0.8451	0.8481	0.8511	0.85				

TABLE 9—TRIGONOMETRIC FUNCTIONS—Cont'd

Angle in degrees	Name of function	Value of function for each tenth of a degree										Angle in degrees	Name of function	Value of function for each tenth of a degree									
		0.0	0.1	0.2	0.3	0.4	0.5	0.6	0.7	0.8	0.9			0.0	0.1	0.2	0.3	0.4	0.5	0.6	0.7	0.8	0.9
50	sin	0.7660	0.7672	0.7683	0.7694	0.7705	0.7716	0.7727	0.7738	0.7749	0.7760	75	sin	0.9659	0.9664	0.9668	0.9673	0.9677	0.9681	0.9686	0.9690	0.9694	0.9699
	cos	0.6428	0.6414	0.6401	0.6388	0.6374	0.6361	0.6347	0.6334	0.6320	0.6307		cos	0.2588	0.2571	0.2554	0.2538	0.2521	0.2504	0.2487	0.2470	0.2453	0.2436
	tan	1.1918	1.1960	1.2002	1.2045	1.2088	1.2131	1.2174	1.2218	1.2261	1.2305		tan	3.7321	3.7583	3.7848	3.8118	3.8391	3.8667	3.8947	3.9232	3.9520	3.9812
51	sin	0.7771	0.7782	0.7793	0.7804	0.7815	0.7826	0.7837	0.7848	0.7859	0.7869	76	sin	0.9703	0.9707	0.9711	0.9715	0.9720	0.9724	0.9728	0.9732	0.9736	0.9740
	cos	0.6293	0.6280	0.6266	0.6252	0.6239	0.6225	0.6211	0.6198	0.6184	0.6170		cos	0.2419	0.2402	0.2385	0.2368	0.2351	0.2334	0.2317	0.2300	0.2284	0.2267
	tan	1.2349	1.2393	1.2437	1.2482	1.2527	1.2572	1.2617	1.2662	1.2708	1.2753		tan	4.0108	4.0408	4.0713	4.1022	4.1335	4.1653	4.1976	4.2303	4.2635	4.2972
52	sin	0.7880	0.7891	0.7902	0.7912	0.7923	0.7934	0.7944	0.7955	0.7965	0.7976	77	sin	0.9714	0.9718	0.9721	0.9725	0.9729	0.9733	0.9737	0.9741	0.9745	0.9749
	cos	0.6157	0.6143	0.6129	0.6115	0.6101	0.6088	0.6074	0.6060	0.6046	0.6032		cos	0.2250	0.2233	0.2215	0.2198	0.2181	0.2164	0.2147	0.2130	0.2113	0.2096
	tan	1.2799	1.2846	1.2892	1.2938	1.2985	1.3032	1.3079	1.3127	1.3175	1.3222		tan	4.3315	4.3662	4.4015	4.4373	4.4737	4.5107	4.5483	4.5864	4.6252	4.6646
53	sin	0.7986	0.7997	0.8007	0.8018	0.8028	0.8039	0.8049	0.8059	0.8070	0.8080	78	sin	0.9781	0.9785	0.9789	0.9792	0.9796	0.9799	0.9803	0.9806	0.9810	0.9813
	cos	0.6018	0.6004	0.5990	0.5976	0.5962	0.5948	0.5934	0.5920	0.5906	0.5892		cos	0.2079	0.2062	0.2045	0.2028	0.2011	0.1994	0.1977	0.1959	0.1942	0.1925
	tan	1.3270	1.3319	1.3367	1.3416	1.3465	1.3514	1.3564	1.3613	1.3663	1.3713		tan	4.7046	4.7453	4.7867	4.8288	4.8716	4.9152	4.9594	5.0045	5.0505	5.0970
54	sin	0.8090	0.8100	0.8111	0.8121	0.8131	0.8141	0.8151	0.8161	0.8171	0.8181	79	sin	0.9810	0.9820	0.9823	0.9826	0.9829	0.9833	0.9836	0.9839	0.9842	0.9845
	cos	0.5878	0.5864	0.5850	0.5835	0.5821	0.5807	0.5793	0.5779	0.5764	0.5750		cos	0.1908	0.1891	0.1874	0.1857	0.1840	0.1822	0.1805	0.1788	0.1771	0.1754
	tan	1.3764	1.3814	1.3865	1.3916	1.3968	1.4019	1.4071	1.4124	1.4176	1.4229		tan	5.1446	5.1929	5.2422	5.2924	5.3435	5.3955	5.4486	5.5026	5.5578	5.6140
55	sin	0.8192	0.8202	0.8211	0.8221	0.8231	0.8241	0.8251	0.8261	0.8271	0.8281	80	sin	0.9848	0.9851	0.9854	0.9857	0.9860	0.9863	0.9866	0.9869	0.9871	0.9874
	cos	0.5736	0.5721	0.5707	0.5693	0.5678	0.5664	0.5650	0.5635	0.5621	0.5606		cos	0.1736	0.1719	0.1702	0.1685	0.1668	0.1650	0.1633	0.1616	0.1599	0.1582
	tan	1.4281	1.4335	1.4388	1.4442	1.4496	1.4550	1.4605	1.4659	1.4715	1.4770		tan	5.6713	5.7297	5.7894	5.8502	5.9124	5.9758	6.0405	6.1066	6.1742	6.2432
56	sin	0.8290	0.8300	0.8310	0.8320	0.8329	0.8339	0.8348	0.8358	0.8368	0.8377	81	sin	0.9877	0.9880	0.9882	0.9885	0.9888	0.9890	0.9893	0.9895	0.9898	0.9900
	cos	0.5592	0.5577	0.5563	0.5548	0.5534	0.5519	0.5505	0.5490	0.5476	0.5461		cos	0.1561	0.1544	0.1527	0.1510	0.1493	0.1475	0.1458	0.1441	0.1424	0.1409
	tan	1.4826	1.4882	1.4938	1.4994	1.5051	1.5108	1.5166	1.5224	1.5282	1.5340		tan	6.3138	6.3859	6.4596	6.5350	6.6122	6.6912	6.7720	6.8548	6.9395	7.0264
57	sin	0.8387	0.8396	0.8406	0.8415	0.8425	0.8434	0.8443	0.8453	0.8462	0.8471	82	sin	0.9903	0.9905	0.9907	0.9910	0.9912	0.9914	0.9917	0.9919	0.9921	0.9923
	cos	0.5446	0.5432	0.5417	0.5402	0.5388	0.5373	0.5358	0.5343	0.5328	0.5313		cos	0.1392	0.1375	0.1357	0.1340	0.1322	0.1305	0.1288	0.1271	0.1253	0.1236
	tan	1.5399	1.5458	1.5517	1.5577	1.5637	1.5697	1.5757	1.5818	1.5880	1.5941		tan	7.1154	7.2066	7.3002	7.3962	7.4947	7.5958	7.6996	7.8062	7.9158	8.0285
58	sin	0.8480	0.8490	0.8499	0.8508	0.8517	0.8526	0.8536	0.8545	0.8554	0.8563	83	sin	0.9925	0.9928	0.9930	0.9932	0.9934	0.9936	0.9938	0.9940	0.9942	0.9943
	cos	0.5299	0.5284	0.5270	0.5255	0.5240	0.5225	0.5210	0.5195	0.5180	0.5165		cos	0.1219	0.1201	0.1184	0.1167	0.1149	0.1132	0.1115	0.1097	0.1080	0.1063
	tan	1.6003	1.6066	1.6128	1.6191	1.6255	1.6319	1.6383	1.6447	1.6512	1.6577		tan	8.1443	8.2636	8.3863	8.5126	8.6427	8.7769	8.9152	9.0579	9.2052	9.3572
59	sin	0.8572	0.8581	0.8590	0.8599	0.8607	0.8616	0.8625	0.8634	0.8643	0.8652	84	sin	0.9945	0.9947	0.9949	0.9951	0.9952	0.9954	0.9956	0.9957	0.9959	0.9960
	cos	0.5150	0.5135	0.5120	0.5105	0.5090	0.5075	0.5060	0.5045	0.5030	0.5015		cos	0.1045	0.1028	0.1011	0.0993	0.0976	0.0958	0.0941	0.0924	0.0906	0.0889
	tan	1.6643	1.6709	1.6775	1.6842	1.6909	1.6977	1.7045	1.7113	1.7182	1.7251		tan	9.5114	9.6768	9.8448	10.019	10.199	10.385	10.579	10.780	10.985	11.205
60	sin	0.8660	0.8669	0.8678	0.8686	0.8695	0.8704	0.8712	0.8721	0.8729	0.8738	85	sin	0.9962	0.9963	0.9965	0.9966	0.9968	0.9969	0.9971	0.9972	0.9973	0.9974
	cos	0.5000	0.4985	0.4970	0.4955	0.4939	0.4924	0.4909	0.4894	0.4879	0.4863		cos	0.0872	0.0854	0.0837	0.0819	0.0802	0.0785	0.0767	0.0750	0.0732	0.0715
	tan	1.7321	1.7391	1.7461	1.7532	1.7603	1.7675	1.7747	1.7820	1.7893	1.7966		tan	11.430	11.665	11.909	12.163	12.429	12.706	12.996	13.300	13.617	13.951
61	sin	0.8746	0.8755	0.8763	0.8771	0.8780	0.8788	0.8796	0.8805	0.8813	0.8821	86	sin	0.9976	0.9977	0.9978	0.9979	0.9980	0.9981	0.9982	0.9983	0.9984	0.9985
	cos	0.4848	0.4833	0.4818	0.4802	0.4787	0.4772	0.4756	0.4741	0.4726	0.4710		cos	0.0698	0.0680	0.0663	0.0645	0.0628	0.0610	0.0593	0.0576	0.0558	0.0541
	tan	1.8040	1.8115	1.8190	1.8265	1.8341	1.8418	1.8495	1.8572	1.8650	1.8728		tan	14.301	14.669	15.056	15.464	15.895	16.350	16.832	17.343	17.886	18.465
62	sin	0.8829	0.8838	0.8846	0.8854	0.8862	0.8870	0.8878	0.8886	0.8894	0.8902	87	sin	0.9986	0.9987	0.9988	0.9989	0.9990	0.9991	0.9992	0.9993	0.9994	0.9995
	cos	0.4695	0.4679	0.4664	0.4648	0.4633	0.4617	0.4602	0.4586	0.4571	0.4555		cos	0.0523	0.0506	0.0488	0.0471	0.0454	0.0436	0.0419	0.0401	0.0383	0.0366
	tan	1.8807	1.8887	1.8967	1.9047	1.9128	1.9210	1.9292	1.9375	1.9458	1.9542		tan	19.081	19.740	20.417	21.205	22.022	22.904	23.859	24.898	26.031	27.272
63	sin	0.8910	0.8918	0.8926	0.8934	0.8942	0.8949	0.8957	0.8965	0.8973	0.8980	88	sin	0.9994	0.9995	0.9995	0.9996	0.9996	0.9997	0.9997	0.9997	0.9998	0.9998
	cos	0.4540	0.4524	0.4509	0.4493	0.4478	0.4462	0.4446	0.4431	0.4415	0.4399		cos	0.0349	0.0332	0.0314	0.0297	0.0279	0.0262	0.0244	0.0227	0.0209	0.0192
	tan	1.9626	1.9711	1.9797	1.9883	1.9970	2.0057	2.0145	2.0233	2.0322	2.0413		tan	28.636	30.145	31.821	33.694	35.801	38.189	40.917	44.066	47.740	52.081
64	sin	0.8988	0.8996	0.9003	0.9011	0.9018	0.9026	0.9033	0.9041	0.9048	0.9056	89	sin	0.9998	0.9999	0.9999	0.9999	0.9999	1.0000	1.0000	1.0000	1.0000	1.0000
	cos	0.4384	0.4368	0.4352	0.4337	0.4321	0.4305	0.4289	0.4274	0.4258	0.4242		cos	0.0175	0.0157	0.0140	0.0122	0.0105	0.0087	0.0070	0.0052	0.0035	0.0017
	tan	2.0503	2.0594	2.0686	2.0778	2.0872	2.0965	2.1060	2.1155	2.1251	2.1348		tan	57.290	63.657	71.615	81.847	95.490	114.550	143.24	190.98	256.48	372.96
65	sin	0.9063	0.9070	0.9078	0.9085	0.9092	0.9100	0.9107	0.9114	0.9121	0.9128	90	sin	1.0000	1.0000	1.0000	1.0000	1.0000	1.0000	1.0000	1.0000	1.0000	1.0000
	cos	0.4226	0.4210	0.4195	0.4179	0.4163	0.4147	0.4131	0.4115	0.4099	0.4083		cos	0.0000	0.0000	0.0000	0.0000	0.0000	0.0000	0.0000	0.0000	0.0000	0.0000
	tan	2.1445	2.1543	2.1642	2.1742	2.1842	2.1943	2.2045	2.2148	2.2251	2.2355		tan	∞	∞	∞	∞	∞	∞	∞	∞	∞	∞

Law of sines

TABLE 8—EXPONENTIAL FUNCTIONS e^{-x}

X	0	0.01	0.02	0.03	0.04	0.05	0.06	0.07	0.08	0.09
0	1.00000	0.99005	0.98020	0.97045	0.96079	0.95123	0.94176	0.93239	0.92312	0.91393
0.1	0.90484	0.89583	0.88692	0.87810	0.86936	0.86071	0.85214	0.84366	0.83527	0.82696
.2	0.81873	0.81058	0.80252	0.79453	0.78663	0.77880	0.77105	0.76338	0.75578	0.74826
.3	0.74082	0.73345	0.72615	0.71892	0.71177	0.70469	0.69768	0.69073	0.68386	0.67706
.4	0.67032	0.66365	0.65705	0.65051	0.64404	0.63763	0.63128	0.62500	0.61878	0.61263
.5	0.60653	0.60050	0.59452	0.58860	0.58275	0.57695	0.57121	0.56553	0.55990	0.55433
.6	0.54881	0.54335	0.53794	0.53259	0.52729	0.52205	0.51685	0.51171	0.50662	0.50158
.7	0.49659	0.49164	0.48675	0.48191	0.47711	0.47237	0.46767	0.46301	0.45841	0.45384
.8	0.44933	0.44486	0.44043	0.43605	0.43171	0.42741	0.42316	0.41895	0.41478	0.41066
.9	0.40657	0.40252	0.39852	0.39455	0.39063	0.38674	0.38289	0.37908	0.37531	0.37158
1.0	0.36788	0.36422	0.36059	0.35701	0.35345	0.34994	0.34646	0.34301	0.33960	0.33622
1.1	0.33287	0.32956	0.32628	0.32303	0.31982	0.31664	0.31349	0.31037	0.30728	0.30422
1.2	0.30119	0.29820	0.29523	0.29229	0.28938	0.28650	0.28365	0.28083	0.27804	0.27527
1.3	0.27253	0.26982	0.26714	0.26448	0.26185	0.25924	0.25666	0.25411	0.25158	0.24908
1.4	0.24660	0.24414	0.24171	0.23931	0.23693	0.23457	0.23224	0.22993	0.22764	0.22537
1.5	0.22313	0.22091	0.21871	0.21654	0.21438	0.21225	0.21014	0.20805	0.20598	0.20393
1.6	0.20190	0.19989	0.19790	0.19593	0.19398	0.19205	0.19014	0.18825	0.18637	0.18452
1.7	0.18268	0.18087	0.17907	0.17728	0.17552	0.17377	0.17204	0.17033	0.16864	0.16696
1.8	0.16530	0.16365	0.16203	0.16041	0.15882	0.15724	0.15567	0.15412	0.15259	0.15107
1.9	0.14957	0.14808	0.14661	0.14515	0.14370	0.14227	0.14086	0.13946	0.13807	0.13670
2.0	0.13534	0.13399	0.13266	0.13134	0.13003	0.12873	0.12745	0.12619	0.12493	0.12369
2.1	0.12246	0.12121	0.12003	0.11881	0.11765	0.11648	0.11533	0.11418	0.11304	0.11192
2.2	0.11080	0.10970	0.10861	0.10753	0.10646	0.10540	0.10435	0.10331	0.10228	0.10127
2.3	0.10026	0.09926	0.09827	0.09730	0.09633	0.09537	0.09442	0.09348	0.09255	0.09163
2.4	0.09072	0.08982	0.08892	0.08804	0.08716	0.08629	0.08543	0.08458	0.08374	0.08291
2.5	0.08208	0.08127	0.08046	0.07966	0.07887	0.07808	0.07730	0.07654	0.07577	0.07502
2.6	0.07427	0.07353	0.07280	0.07208	0.07136	0.07065	0.06995	0.06925	0.06856	0.06788
2.7	0.06721	0.06654	0.06587	0.06522	0.06457	0.06393	0.06329	0.06266	0.06204	0.06142
2.8	0.06081	0.06020	0.05961	0.05901	0.05843	0.05784	0.05727	0.05670	0.05613	0.05558
2.9	0.05502	0.05448	0.05393	0.05340	0.05287	0.05234	0.05182	0.05130	0.05079	0.05029
3.0	0.04979	0.04929	0.04880	0.04832	0.04783	0.04736	0.04689	0.04642	0.04596	0.04550
3.1	0.04505	0.04460	0.04416	0.04372	0.04328	0.04285	0.04243	0.04200	0.04159	0.04117
3.2	0.04076	0.04036	0.03996	0.03956	0.03916	0.03877	0.03839	0.03801	0.03763	0.03725
3.3	0.03688	0.03652	0.03615	0.03579	0.03544	0.03508	0.03474	0.03439	0.03405	0.03371
3.4	0.03337	0.03304	0.03271	0.03239	0.03206	0.03175	0.03143	0.03112	0.03081	0.03050
3.5	0.03020	0.02990	0.02960	0.02930	0.02901	0.02872	0.02844	0.02816	0.02788	0.02760
3.6	0.02732	0.02705	0.02678	0.02652	0.02625	0.02599	0.02573	0.02548	0.02522	0.02497
3.7	0.02472	0.02448	0.02423	0.02399	0.02375	0.02352	0.02328	0.02305	0.02282	0.02260
3.8	0.02237	0.02215	0.02193	0.02171	0.02149	0.02128	0.02107	0.02086	0.02065	0.02045
3.9	0.02024	0.02004	0.01984	0.01964	0.01945	0.01925	0.01906	0.01887	0.01869	0.01850
4.0	0.01832	0.01813	0.01795	0.01777	0.01760	0.01742	0.01725	0.01708	0.01691	0.01674
4.1	0.01657	0.01641	0.01624	0.01608	0.01592	0.01576	0.01561	0.01545	0.01530	0.01515
4.2	0.01500	0.01485	0.01470	0.01455	0.01441	0.01426	0.01412	0.01398	0.01384	0.01370
4.3	0.01357	0.01343	0.01330	0.01317	0.01304	0.01291	0.01278	0.01265	0.01253	0.01240
4.4	0.01228	0.01216	0.01203	0.01191	0.01180	0.01168	0.01156	0.01145	0.01133	0.01122
4.5	0.01111	0.01100	0.01089	0.01078	0.01067	0.01057	0.01046	0.01036	0.01025	0.01015
4.6	0.01005	0.00995	0.00985	0.00975	0.00966	0.00956	0.00947	0.00937	0.00928	0.00919
4.7	0.00910	0.00900	0.00892	0.00883	0.00874	0.00865	0.00857	0.00848	0.00840	0.00831
4.8	0.00823	0.00815	0.00807	0.00799	0.00791	0.00783	0.00775	0.00767	0.00760	0.00752
4.9	0.00745	0.00737	0.00730	0.00723	0.00715	0.00708	0.00701	0.00694	0.00687	0.00681
5.0	0.00674

EXTENSION TABLE A*

X	0.001	0.002	0.003	0.004	0.005	0.006	0.007	0.008	0.009
e^{-x}	0.99900	0.99800	0.99700	0.99601	0.99501	0.99402	0.99302	0.99203	0.99104

EXTENSION TABLE B*

X	0.0001	0.0002	0.0003	0.0004	0.0005	0.0006	0.0007	0.0008	0.0009
e^{-x}	0.99990	0.99980	0.99970	0.99960	0.99950	0.99940	0.99930	0.99920	0.99910

*General Formula: $e^{-(x+x_A+x_B)} = (e^{-x})(e^{-x_A})(e^{-x_B})$
 Example: $e^{-0.1365} = (e^{-0.13})(e^{-0.006})(e^{-0.0005})$
 $= (0.87810)(0.99402)(0.99950) = 0.87241$

INDEX

	PAGE		PAGE
ABCD Constants		Aluminum Conductors—	
Circle Diagram	278	Characteristics of	32, 50
Definition	332	Ammeter—Surge Crest	553
Example of Calculations	465, 466	Analog Computer	503, 519
Network Combination	327	Angle, Internal, of Synchronous	
Transmission Line	266, 268, 270	Machines	149
Transmission Type Network	328, 329	Angle Time or Swing Curves	457, 464
A-C Network Calculator		Arc Characteristics—Transient	
Circuit Elements	475	Voltages	512
Description	475	Arc Furnace	726
Fault Calculations for Relay and		Demand Charts	727
Circuit-Breaker Application		Electrical Characteristics	727
.	389, 457, 501	Series Capacitor Application	263
Step-by-Step Calculation	458 to 460	Arcing	
Synchronous Machine		Horns, Typical Practice	792, 796
Representation	172, 175	Rings, Typical Practice	596, 792, 796
Transient Stability Studies	457, 476	Arcing Grounds	627
Transient Studies	501, 502	Field Test Data	517
Uses	476	Laboratory Test Data	513 to 516
Acceleration, in Stability		Theory	511
Studies	458, 463, 468	Arcing Rings on Insulators	596
Acoustic Shock	745, 746, 753	Attenuation	
Acoustic Shock Reducer	753	Effect of Series Resistance	536
Admittance		Effect of Wave Front	540
Constants for Circle Diagram	332	Effect of Wave Polarity	540
Driving Point and Transfer	332	Empirical Data	538
Parallel	307	Power Line Carrier Systems	425, 428
Representation of Loads	294	Traveling Wave	536 to 540
Symmetrical Components	17	Units of	410
Aerial Conductors		Autotransformers	
A.C.S.R., Characteristics of	50	Advantages	117, 119
Clearance, Minimum	587, 792 to 797	Disadvantages	117
Copper, Characteristics of	49	Efficiency	117, 119
Copperweld, Characteristics of	53	Equivalent Circuit, Three-	
Copperweld-Copper, Character-		Winding	141 to 144, 799, 801, 805
istics of	52	Equivalent Circuits, Two-	
Current Carrying Capacity	47, 48	Winding	117, 799, 800, 805
Expanded A.C.S.R.	32, 50	Grounding	119, 664
Geometric Mean Radius	36	Impedance	117, 119
Hollow (Anaconda)	32	Kva Parts	116, 117
Hollow (Type HH)	33	Operating Characteristics	119
Impedance—See <i>Aerial Lines</i>		Taps	118, 119
Skin Effect	34	Tertiary Currents During Faults	119
Spacing, Transmission Line		Tertiary Rating	118
.	8, 587 to 592, 792 to 797	Theory	116, 117
Steel	34	Three-Winding	118
Steel Ground Wires	34	Three-Winding Kva Parts	118
Temperature Effect on		Volts per Turn	118, 119
Resistance	33, 34	Zero-Sequence Impedance	143, 144
Temperature Rise	47, 48, 49	Balanced System with Sequence	
Types	32, 33	Components	21
Aerial Lines—See Also <i>Transmission Line</i>		Balancing Transformers	713
Capacitive Reactance	46, 47	Banked Transformers	683, 684
Characteristics of—Chap. 3	32	Base Kva	295
Conductors—See <i>Aerial Conductors</i>		Base Voltage	295
Equivalent Spacing	8, 37, 38	Basic Impulse Insulation Level—	
Geometric Mean Distance	38	See Also <i>Insulation Coordination</i>	
Inductive Reactance	34, 35	Reduced	611
Minimum Conductor to Tower		Selection of	612
Clearance	587, 792 to 797	Standard	611
Parallel Circuits, Reactance	40	Bonding, Cable, Effect of	74
Positive-and Negative-Sequence		Burning Clear Secondary Faults	
Reactance	34 to 40	702 to 704, 712, 714, 715
Resistance	33, 34	Bus-Conductors	
Reactance Curves	38, 39	Channel	397
Reactance Spacing Factors	54, 55	Impedance Data	396
Transposition	37, 38	Layouts—Power Station	9, 10, 11
Typical Constants	279, 280, 395, 396	Protection	354
Typical Construction	8, 587 to 592,	Rectangular	396
.	785 to 789, 792 to 797	Structure—Metal Clad	10
Typical Impedance Data		Square Tubular	397
.	279, 280, 395, 396	Bushings	
Zero-Sequence Impedance		Standard Test Voltages	620
Derivation	41 to 44	Volt-Time Characteristics of	619
Formulas	45	Cable	
Air-Blast Equipment	685, 696	Aerial—See <i>Aerial Conductors</i>	
Air Circuit Breakers—See		Approximate Impedance Data	395
<i>Circuit Breakers, Air</i>		Belted	64
Air-Flashover of Standard Rod Gaps	583	Bonding, Effect of	74
Aluminum Cable—Characteristics of		Capacitive Reactance	79 to 85
.	32, 50	Characteristics of	79 to 85
Aluminum Cable Steel Reinforced		Compression	65
Characteristics of	32, 50	Conductor Shape	65, 66
Description	32	Cable (continued)	
Expanded	50	Construction	64
		Current Carrying Capacity	
		Discussion	81, 84
		Tables	86 to 92
		Current Division of Paralleled	84, 94
		Dielectric Constant of Insulation	78
		Effect of Iron Conduit	395
		Electrical Characteristics	66, 78, 84
		Gas Filled	65
		Geometric Factor	68, 69, 70
		Geometric Mean Distance	67, 72 to 77
		Geometric Mean Radius	
		66, 67, 72 to 77
		Geometry of Cross Section	66, 67
		Grounding, Effect of	74
		High Pressure	65
		Impedance—Low Voltage Cables	73
		Impedance of Parallel	84, 94
		Impulse Strength	93, 94
		Insulation Resistance	78
		Lead Sheathed	64
		Oil Filled	64, 65
		Overhead—See <i>Aerial Conductors</i>	
		Paper Insulated	64
		Parallel	84, 94
		Positive and Negative-Sequence	
		Impedance	84, 94
		Positive-and Negative-Sequence	
		Reactance	72
		Pressure	65
		Propagation of Surge, Velocity	525
		Proximity Effect	68, 70, 71
		Resistance A-C	68, 70 to 72
		Resistance and Reactance	
		Tables	79 to 85
		Sector	65, 66, 67
		Segmental	66
		Sheath Currents, Effect of	71
		Shielded	64
		Shunt Capacitive Reactance	77 to 78
		Skin Effect	68
		Surge Capacitance	524
		Surge Impedance	524
		Surge Inductance	524
		Tables of Characteristics	79 to 85
		Zero-Sequence Impedance	84 to 94
		Zero-Sequence Reactance	74 to 77
		Zero-Sequence Resistance	74 to 77
		Cable, Telephone	
		Coordination, Effect on	753, 779
		Shielding	752
		Special Insulation	753
		Calling Systems for Carrier	
		Communication	404
		Camera, Boy's	546, 547
		Capacitance Coefficients	750
		Capacitance for Surge	524
		Capacitance to ground	
		Induction Motors	186
		Synchronous Machine	185, 186
		Capacitances, Transmission Lines	644
		Also see <i>Aerial Lines</i>	
		Capacitive Loading, Unbalanced Short	
		Circuit	179
		Capacitive Reactance	
		Aerial Lines	46, 47
		Cable	79 to 85
		Formulas	47, 77, 78
		Tables	49 to 53, 55, 79 to 85
		Capacitors—See <i>Series Capacitors</i>	
		and <i>Shunt Capacitors</i>	
		Application to Power Systems—	
		Chap. 8	233
		Protection of Rotating Machines	639
		Capacity Factor	1, 2
		Carrier—See <i>Power-Line Carrier</i>	
		Carrier-Frequency Systems	
		Coordination	746, 747, 779
		Carrier—Pilot Relaying	361
		Directional Comparison System	362
		Phase Comparison System	362
		Carson's Formulas	40, 41
		Cathode-Ray Oscillograph	553, 561
		Cathodic Protection	746

PAGE		PAGE		PAGE
	Central-Station Industry	1		
	Channel Bus Conductors, Reactance of	397		
	Characteristic Impedance	409		
	Characteristics, Electrical of Cables— see <i>Cable</i>			
	Characteristics of Aerial Lines— Chap. 3	32		
	Charge and Field Distribution in Thunder Clouds	545		
	Choke Coils—Longitudinal	754, 756		
	Chopped Wave Surge	619		
	Circle Diagram	324		
	ABCD Constants Used	278		
	Admittance Constants	332		
	Construction	326, 329, 330		
	Determination of Initial Loads	442		
	Equivalent Pi	277		
	Examples of Calculation to Determine Real and Reactive Power Flow	333 to 341		
	For Three Generating Stations Along One Main Line and Intermediate Substation	339		
	For Two-Source System	333		
	Impedance Constants	333		
	Interpretation	324 to 326, 332		
	<i>l, m, n</i> Constants	330		
	Long Transmission Lines	275		
	Loop System	339		
	Power	434, 442		
	Power-System Stability	434		
	Real and Reactive Power Flow	333		
	Short Transmission Lines	273		
	Transmission Line Construction	326 to 333		
	Interpretation	324 to 326, 332		
	Use	324 to 326		
	Circuit Breakers			
	Abnormal Operating Conditions	387		
	Air—See <i>Circuit Breakers, Air</i>			
	Application, Fault Calculation	339, 395		
	Cascade	388		
	Compressed Air	379		
	Conditions Assumed in Rating of	381		
	Control Schemes for	376		
	Current Rating of	381		
	De-ionizing Time	491		
	De-Rating Factors	382		
	Duty Cycle of	382		
	Effect of Altitude on Ratings	381		
	Equivalent Three-Phase Ratings of	384 to 389		
	Four-Pole Equivalent Rating	385, 386		
	Frequency Rating of	381		
	High-Voltage	380		
	Independent Pole Equivalent Rating	385		
	Interrupting Capacity at Reduced Voltage	382		
	Interrupting Capacity—Factors for Obtaining	390		
	Interrupting Current Rating of	381		
	Interrupting Time of	381		
	Latching Current Rating of	384		
	Low-Voltage	378		
	Low-Voltage in Cascade	388		
	Low Voltage, Reactance of Series Trip Coils	396		
	Making and Latching Current Rating of	384		
	Mechanical Stresses in, Factors for Obtaining Current that Determines	390		
	Medium-Voltage	379		
	Neutral Equivalent Rating	385		
	Non Oil-Tight	382		
	Oil, Pictures of	380, 381		
	Oil-Tight	382		
	Operating Duty of	382		
	Primary Feeder	671		
	Reclosing Duty Cycle Factors	382		
	Reclosing Time of	382		
	Selective Tripping	388		
	Selector in Generating Stations	10		
	Short-Time Current Ratings of	383		
	Circuit Breakers (continued)			
	Single-Phase Equivalent Rating	387		
	Single-Phase Switching	491		
	Single Pole Equivalent Rating Solidly Grounded Systems	385 to 387 652		
	Stability—Quick Fault Clearing 463, 470, 478, 490 to 492			
	Stability—Quick Reclosure	438, 490		
	Standard and Equivalent Rat- ings	384 to 387		
	Switching Capacitive Current	387		
	Trip-Free Control	377		
	Tripping, A-C	378		
	Two-Phase Equivalent Rating	386		
	Two Pole Equivalent Rating Voltage Rating of	385 to 387 381		
	Circuit Breakers, Air			
	Cascade	388		
	Factors for Selecting Interrupting Rating	390		
	Low Voltage, Reactance of Series Trip Coils	396 to 398		
	Operating Duty	383		
	Pictures of	378, 379		
	Selective Tripping	388		
	Circuit Constants—General Transmission	327		
	Circuit Current, Momentary Rating	383, 390		
	Clouds—See <i>Thunderclouds</i>			
	Coal—Pounds per Kw-hr	2		
	Communication Circuits and Un- grounded Neutral Systems	650, 651		
	Communication Circuits Drainage Schemes	754		
	Communication Circuits Susceptive- ness	745, 752		
	Special Low-Frequency Protec- tive Measures	753		
	Telephone-Circuit Low-Frequency Protection	752		
	Telephone-Circuit Noise-Frequency Factors	778		
	Communication System, Power-Line Carrier	401		
	Automatic Simplex	403		
	Calling Systems	404		
	Duplex	401, 402		
	Emergency	405		
	Hybrid Unit	402, 403		
	Power Supply	405		
	Simplex	401, 402		
	Compensation Theorem—for Network Solution	301		
	Completely Self-Protecting Transformers	630, 637, 638		
	Complex Hyperbolic Functions	267		
	Condensers—See <i>Synchronous Condensers</i>			
	Conduction (between Power and Communication System)	742		
	Conductors See <i>Aerial Conductors, Cable, Bus Conductors</i>			
	Clearances, Minimum	587, 792, 796		
	Spacing Transmission Lines	8, 792, 796		
	Conduit, Approximate Effect of Iron on Impedance of Cables	396		
	Conjugate Sets of Vectors	20, 21		
	Constants—Synchronous Machines (See <i>Synchronous Machines</i>)			
	Construction Details of Typical Lines 8, 587 to 592, 785 to 789, 792 to 797			
	Conversion—Different Kva Base	295		
	Conversion—Different Voltage Base	295		
	Conversion Formulas for Transmission- Type Networks	327		
	Coordination of Power and Communication Systems	741		
	Cooperation, Principle of	745		
	Duty of	745		
	Effects	741, 745, 756		
	Engineering Solution	745		
	Factors, Basic	745		
	Coordination of Power and Com- munication Systems (continued)			
	Measures General (Definition)	745		
	Specific	746, 747, 754 to 756, 772 to 775, 776 to 779		
	Practices Deferred	746		
	Standard	745		
	Principles, Basic	741		
	Procedure	745, 746		
	Copper Conductors			
	Copperweld	33		
	Copperweld-Copper	33		
	Hollow (Anaconda)	32		
	Hollow (Type HH)	33		
	Core Form Transformers	104, 105, 138		
	Corona	56 to 62		
	Bundle Conductors	60 to 62		
	Conductor Condition	56		
	Conductor Selection	60		
	Effect on Front of Negative Voltage Waves	540		
	Effect on Traveling Waves	538		
	Energy Loss	539		
	Factors Affecting	56		
	Loss Curves—Comparative	57 to 60		
	Loss Curves for Design	61		
	Loss, Fair Weather	57 to 60		
	Prevention by Shielding in Cable	64		
	Radio Influence	58 to 60		
	Radio Influence Curves	62		
	Cost			
	Capacitors vs. Synchronous Condensers	255		
	Induction Motor	193		
	Synchronous Machines	190		
	Inertia Constant	190		
	Short Circuit Ratio	190		
	Transformer	131 to 133		
	Counterpoise Arrangements	594, 595		
	Depth Below Surface	595		
	Grounding	594, 595		
	Propagation of Surge	525		
	Typical Practice	785 to 789, 792 to 797		
	Coupling Capacitors	415		
	Coupling Factor Between Conductor and Two Ground Wires for Traveling Wave	535		
	Electric Induction	749, 750		
	Magnetic Induction, Low Frequency Aerial Circuits	747		
	Carson's Method	749		
	Earth-Return Circuits	748		
	Noise-Frequency	752		
	Power and Communication Circuits	745		
	Transpositions	752, 776, 780 to 782		
	Traveling Waves	534		
	Coupling—Lightning Protection	582		
	Current Division	316		
	Example	308, 312, 316, 317		
	Current—Due to Ground Fault	657, 658		
	Current Flow—Sequence Networks	22		
	Current—Symmetrical Components on Three-Phase System	19		
	Current Transformers—Approximate Impedance for Short-Circuit Calculations	397		
	Damper Windings Balancing Action	182		
	Effect on Stability	456, 486		
	Effect upon X_2 and R_2	182, 183		
	Elimination of Distortion	182		
	Hunting	183		
	Ratio X_d''/X_d'	182, 183		
	Stability Effects on	456, 486		
	Types	181 to 183		
	D-C Machines Internal Inductance of	761		
	Wave Shape	761, 772		

	PAGE		PAGE		PAGE
D-C Transmission	494	Equivalent Circuits (continued)		Faults (continued)	
Decibel	424, 425	T	267	Power-System	
Decibel Scale	780	Transformers	799 to 809	Arc-Suppression Measures	494
Decrements Similar Parallel Machines	393, 394	Equivalent Impedances for Transmission Lines		Current Curves	497, 498, 499
De-ion Tube—See <i>Protector Tube</i>		Equivalent Pi	267 to 269	Current Formulas	497
Delta-Star Conversion	17, 18, 306	Equivalent T	267, 268	De-Ionizing Time	489
Delta-Star Transformation of Voltage and Current	19, 20	Simplified Methods	267 to 270	Effect on Stability	438, 482, 491
Depth of Penetration—Surges	537	Equivalent Networks	305	Flashover-Prevention Measures	494
Design Features of Lines	785 to 789, 792 to 797	Representation of Induction	744	Representation in Stability Studies	442, 462, 466
Determinants	303	Representation of Long Lines at Harmonic Frequencies	771	Voltage Curves	497 to 499
Deviation Factors of Synchronous Machines	760	Equivalent Pi of Transmission System	328	Voltage Formulas	497
Diesel Engine—Light Flicker	721	Equivalent Spacing on Unsymmetrical Lines	37, 38	Reactance Data to Use	395
Differential Protection		Equivalent T of Transmission System	328	Single Line-to-Ground	23, 25
Generators, A-C	348	Excitation Change on Synchronous Machines	165 to 172	Synchronous Machine	152, 158, 176 to 181
Resistance Grounded Generators	663	Excitation Response Curves	170, 172, 489	Three Phase	22, 25
Transformers	348	Excitation—Synchronous Machines, Fundamental Equation	166	Typical Clearing Times 785 to 789, 792 to 795	
Direct Stroke Protection	578, 579, 630, 631	Excitation Systems—Chap. 7	195	Voltages and Currents During	369 to 372
Direct Stroke Theory	578, 579	Ceiling Voltage	196	Feeder Breakers	
Directional Relaying for Bus Protection	356	Common Exciter Bus	195	Interrupting Duty	699
Disconnect Switches in Power Stations	9	Definitions	196	Primary Network	698
Distortion of Traveling Waves	536	Dynamic Stability of Power System	455	Feeder Losses, Shunt Capacitors to Reduce	242
Distribution Systems		Effect on Flicker	722	Feeder Voltage Regulators— Approximate Impedance	395
Component Parts	666	Effect on System Stability	195, 455, 487 to 489	Feeders	
Feeders—Primary		Effect on Voltage	169 to 174	Emergency Connections	680
Distribution	666 to 678	History	195	Primary Distribution	666 to 678
Loop Type	684 to 685	Hydroelectric Generator	231	Rating	681
Networks—D-C	667	Per Unit Base	196, 197	Regulation	681
Radial Type	667	Power System Stability	195, 487 to 489	Filters	772 to 776
Recovery Voltage	508	Response Ratio	196, 197	A-C	774, 775
Secondaries	666, 667, 682	Self-Excited	219	Capacitor	766
Shunt Capacitor Application	241	Stability	196	Constant Q	772, 773
Substations	666, 667, 669	Synchronous condenser	223, 224, 231	D-C	775
Subtransmission	666 to 668	Typical Practice	785 to 789	In Neutral	663
Transformers	666, 667, 682	Unit of Voltage	196, 197	Line	766, 774
Driving Point Admittance	332	Exciter—See <i>Electronic Main Exciter</i> , <i>Excitation Systems</i> , <i>Main Exciter</i> , <i>Pilot Exciter</i>		Machine	773
Duplex Communication System	402, 403	Exciter Response	196, 197	Rectifier	774, 775
Dynamic Stability	455, 489	Effect on Power System Stability	195, 455, 487 to 489	Sequence Segregating	373 to 376
Earth Conduction—Effect on Cable Impedance	74 to 77	Effect on Short-Circuit Current	166	Firm Capacity	5
Earth Resistivity	580, 595, 596, 747	Effect on Voltage Drop	172	Flexibility for Load Growth	
Earth-Return Circuits		Exponential Functions	812	Primary Network	693, 696
Low Frequency, at	747 to 749	Extinction Voltage		Secondary Network	710
Noise Frequency, at	776	Definition	517	Flicker—Chap. 22	719
Economics		Effect on Transient Voltages	517 to 521	Comparison Chart	739, 740
Primary Network	694	Fault Bus Relaying Scheme	356	Correction Table	739
Secondary Network	709	Fault Current		Cyclic	719, 720
Electric Furnace—Flicker	725	A-C Component	389	Diesel-Engine Source	721
Electric Furnace—Oscillogram of Power Supply	726	Asymmetrical	389	Distribution Systems	682, 683
Electric Induction Between Circuits	742	Autotransformer Tertiary	119	Due to Generators	721
See Also <i>Noise-Frequency Coordination</i>		Calculation for Coordination of Power and Communication System	747	Due to Heavy Special Equipment	729
Calculation at Low Frequency	747	Damage to Capacitors	243, 247	Due to Prime Movers	721
Electric Welders—Discussion of Various Types	728	D-C Component	389	Effect of Excitation Systems	722
Electrolysis	746	Effect of Location on System	390	Electric Furnaces	725
Electromechanical—Natural Frequency of Synchronous Machines	456	Generators	658	Electric Welders	327
Electronic Main Exciter	212, 213	Induction Motor	191	Frequency of	719
Ignitron Firing Circuit	215	Rms Total Component of	389	History	719
Permanent-Magnet Generator	213, 215	Secondary Network Mains	704, 707, 712, 714, 715	Intermittent Loads	725
Power Supply	216	Shunt Capacitor Banks	244, 245	Motor Starting	723
Response	216	Shunt Capacitor Contribution	256	Origin	721
Service Continuity	215, 216	Symmetrical	389	Perceptible	719
Source of Power	213, 214	Synchronous Machines	152, 158, 176 to 181	Permissible	719, 720
Equipment Symbols for Graphical Representation	291	Faults		Reciprocating Loads	723, 724
Equivalent Circuits		Burning Clear in Secondary Network	702 to 704, 712, 714, 715	Reduced by Series Capacitor	257
ABCD Constants	266 to 268, 270, 278	Calculations for Circuit-Breaker and Relay Application	389	Remedial Measures	731
Fault Representation in Stability Studies	442, 462, 466	Double Line-to-Ground	23, 25	Booster or Compensating Trans- former	738
Long Transmission Lines	265 to 267	Frequency and Distribution of	358	Capacitors	735 to 737
Pi	267, 268, 272	Induction Motor	191	Excitation Control	739
Sequence Networks	21	Line-to-Line	23, 25	Flywheel	732, 733
Short Transmission Lines	265, 270			Load Control	739
Simplification for Stability Studies	473			Motor-Generator Sets	731

PAGE		PAGE		PAGE
	Fluorescent Lamps		Impedance (continued)	
	Coordination Characteristics..... 771		Transmission Lines—See also	
	Wave Shape..... 771		<i>Aerial Lines</i>	
	Flywheel—Effect on		Equivalent Pi..... 267 to 269	
	Peak Demand..... 732, 733		Equivalent T..... 267, 268	
	"Follow-up Method"..... 167, 168		Simplified Method..... 295	
	Four-Wire System—Grounding... 663, 664		Unbalanced, Resolved by Sym-	
	Frequency—Choice of		metrical Components..... 16	
	Power Line Carrier..... 401, 430		Zero Sequence..... 41 to 45	
	Power System..... 6		Impulse Strength	
	Frequency Modulation..... 409		Bushings..... 620	
	Frequency—Weighting Curves		Cables..... 93, 94	
	Power-System Voltages and		Insulators..... 107, 108, 619, 620	
	Currents..... 757		Transformers..... 107, 619, 620	
	Telephone—System Voltages		Impulse Testing—See <i>Surge Testing</i>	
	and Currents..... 779		Inductance for Surge..... 524	
	Fulchronograph		Induction Coordination—See <i>Coordina-</i>	
	Description..... 554		<i>tion of Power and Communication</i>	
	Records..... 572		<i>Systems</i>	
	Fuse Characteristics for		Induction Motor..... 161, 190 to 194	
	Capacitors..... 248, 249		Capacitance to Ground..... 186	
	Fuses—Distribution		Cost..... 193	
	Feeder and Sub Feeder..... 679		Electro-Mechanical Starting	
	Repeater..... 679		Transient..... 192	
	Secondary..... 682, 684		Equivalent Circuit..... 191	
	Substation..... 671, 678		Hunting..... 262	
	Transformer..... 667, 682, 684		Relaying..... 368	
	Fuses, Shunt Capacitor..... 243		Residual Voltage..... 193	
	Gas Filled Cable, See <i>Cable</i>		Self-Excitation..... 240, 241	
	General Transmission Circuit		Shaft Power..... 191	
	Constants..... 327		Short Circuit of..... 191	
	Generating Stations		Shunt Capacitor Application... 241	
	Auxiliary Power Supply..... 10		Sub-Synchronous Resonance... 261	
	Bus Layout..... 8 to 10		Time Constants..... 193	
	Bus-Tie Reactors..... 9		Wave Shape of Supply..... 761	
	Fire Walls..... 10		Induction Regulators—Approximate	
	Operating Problems..... 8 to 11		Impedance Data.....	
	Sealed Compartments..... 10		Inductive Coordination	
	Synchronizing Bus..... 9, 10, 656		Shunt Capacitors..... 253, 254	
	Generators—See <i>Synchronous</i>		Inductive Interference—See <i>Interference</i>	
	<i>Machines</i>		<i>of Power and Communication Systems</i>	
	Geometric Factor, Cable..... 68, 69, 70		Inductive Reactance	
	Geometric Mean Radius		Fundamental Theory..... 34, 35	
	Aerial Conductors..... 36		Parallel Circuits..... 40, 84 to 94	
	Cable..... 66, 67		Positive Sequence..... 34 to 40, 72	
	Governors..... 456		Quick Reference Curves..... 38, 39	
	Grading Shields—Typical		Spacing Factors..... 54	
	Practice..... 792, 796		Zero-Sequence..... 40 to 45, 74 to 77	
	Graphical Symbols for Diagrams		Industrial Plant Networks..... 715, 716	
	Equipment..... 291		Industrial Plants	
	Windings..... 292		Shunt-Capacitor	
	Grid, Interwoven Low-		Application..... 238 to 241	
	Voltage..... 689, 702, 710		Inertia Constant..... 175, 189, 190, 458, 486	
	Ground Currents for Faults..... 657		Inertia, Rotating Machines	
	Ground Fault Current		Effect on Stability 437, 457, 486, 491	
	Calculation..... 657, 658		Equivalent Single-Machine... 457	
	Ground Gradients		Formulas..... 457, 458, 491	
	During Fair Weather..... 542, 550		Inrush Current	
	During Thunderstorms..... 550		Capacitor Banks..... 250 to 252	
	Ground Potential..... 742, 755, 756		Transformers..... 126 to 128	
	Ground Relaying..... 365		Instruments for Measuring	
	Ground—Return Circuits..... 747		Lightning Surges..... 551	
	Ground Wires		Insulating Transformers for Exposed	
	Coupling Factor—Traveling		Communication Circuits..... 755	
	Waves..... 534		Insulation Coordination	
	Transmission Lines..... 579		Basic Concept..... 610	
	Typical Practice 785 to 789, 792 to 797		Basic Impulse Insulation Level... 611	
	Zero-Sequence Formulas..... 45		History..... 610	
	Zero-Sequence Impedance... 41 to 45		Protective Devices, Application of 625	
	Grounded Systems		Protective Devices,	
	Basic Insulation Level..... 611, 612		Characteristics of..... 621	
	Effectively..... 646, 652		Protective Devices, Coordination	
	Reactance..... 646, 647		of with Apparatus	
	Resistance..... 644, 651		Insulation..... 627, 628	
	Resonant or Ground Fault		Reduced Insulation Levels... 611	
	Neutralizer..... 647, 648, 653		Rotating Machines, Surge Pro-	
	Solidly..... 646		tection for..... 638, 639	
	Trends and Practices..... 655		Selection of BIL..... 612	
	Grounding		Standard BIL..... 611	
	Cable, Effect of..... 74		Summary..... 632, 642	
	Circulating Harmonics..... 658		Surge Testing..... 613	
	Communication Circuit		Transformers, Distribution,	
	Influence..... 659		Protection of..... 632	
	Counterpoise..... 594, 595		Insulation Strength of Typical Lines	
		 588 to 590, 785 to 789, 792 to 797	
	Grounding (continued)			
	Damage at Fault Points..... 660			
	Devices—Time Ratings..... 660			
	Distribution Transformer With			
	Secondary Resistor..... 662, 663			
	Driven Rods..... 593, 594			
	Effect of Method of Grounding			
	on Relaying..... 349			
	Effect on Relaying..... 349, 660			
	Effect on Stability..... 484			
	Effect on Transient Voltages 515, 516			
	Four-Wire System..... 663, 664			
	Generator, Trends and Practices. 665			
	Generator with Distribution			
	Type Transformer..... 662 to 663			
	Generators..... 348, 349, 655, 656			
	Ground Fault Detection..... 661			
	History..... 643			
	Inductive Coordination..... 659			
	Neutral Breaker..... 660			
	Potential Transformer..... 661			
	Power System Neutrals..... 643			
	Power System, Trends and			
	Practices..... 655			
	Reactance..... 646, 647, 658			
	Summary Table..... 649, 650			
	Three-Wire System..... 663			
	Time Rating of Neutral			
	Device..... 660, 661			
	Transformers..... 120, 121			
	Transformers Zig-Zag..... 653			
	Transient Overvoltages			
 515 to 521, 652, 659 to 660			
	Transmission System..... 654, 655			
	Transmission Towers			
 785 to 789, 792 to 797			
	Wood Poles..... 596, 598			
	Zig Zag Transformers..... 120			
	Grounds—Arcing..... 511, 659, 660			
	Harmonic Voltage—Shunt Capacitor			
	Capacity for..... 252, 253			
	Harmonic Voltages..... 627			
	Harmonics..... 757, 758			
	See Also <i>Frequency-Weighting</i>			
	<i>Curves</i>			
	See Also <i>Noise-Frequency</i>			
	<i>Coordination</i>			
	See Also <i>Wave Shape of Apparatus</i>			
	<i>or Circuit</i>			
	High Voltage Equipment			
	Lightning Protection..... 632			
	High-Voltage Switch, Secondary Net-			
	work..... 705, 715			
	Hollow Copper Conductors (Anaconda) 51			
	Hollow Copper Conductors (Type HH) 51			
	Hunting			
	Effect of Damper Winding on 182, 183			
	Synchronous Machines—			
	Natural Frequency..... 456			
	Hyperbolic Functions..... 267			
	Ignitron Tube Main Exciter... 213 to 215			
	Impedance			
	Aerial Lines—See <i>Aerial Lines</i>			
	Cable—See <i>Cable</i>			
	Characteristic..... 409			
	Constants for Circle Diagrams... 332			
	Conversion of Ohms to Percent... 294			
	Converting Transformer Impedance			
	to Winding Base..... 589			
	Data for Fault Calculation..... 395			
	Diagram of System..... 290, 291			
	Line Input..... 410, 411			
	Linear..... 310			
	Mesh..... 302			
	Parallel..... 305			
	Relaying..... 360, 361			
	Relaying for Bus Protection... 355			
	Representation of Loads..... 294			
	Self..... 332			
	Series..... 305			
	Surge..... 280, 281, 524			
	Synchronous Machines..... 188, 189			
	Transformers..... 98 to 100, 799 to 808			

	PAGE		PAGE		PAGE
Insulators		Lightning—Chap. 16 (continued)		Low-Frequency Coordination of Power and Communication Systems	
Flashover Characteristic of Suspension Type	597	Surges—Cathode-Ray Oscillogram		Chap. 23—Part II	746 to 756
Flashover Characteristics	583, 615 to 619	Currents	570	Coupling Factors	747
Number on Typical Transmission Lines	785 to 789, 792 to 797	Voltages	561	Electric Induction	749
Size and Spacing	596	Surges—Crest Magnitudes		Magnetic Induction	747
Interference of Power and Communication Systems—See Coordination of Power and Communication Systems		Currents	564	Shielding Conductors	752
Definition	741	Voltages	559	Influence Factors of Power System	747
Types	741	Surges—Current		Neutral Impedances	747
Interlocking of Supply Circuits		Frequency of Occurrence	568	Procedure	746
690, 694, 701, 708, 712		Magnitude	564	Susceptiveness Factors of Communication System	746
Internal Voltage	157, 175	Wave Shape	570	Special Protective Measure	753 to 756
Interrupting Duty in Primary Network	699	Surges—Fronts of	561, 573	Telephone-Circuit Protection	752
Intersection Bus Faults in Primary Network	692	Surges—Long Duration Tails on	574		
Inverters		Surges on Transmission Lines			
Wave Shape (See Rectifier Wave Shape)	766	Direct Strokes	568		
Isokeraunic, Thunderstorm Charts	557, 558	In Arresters	569		
I. T. Factors, Power Systems	758, 772	Induced Surges	559		
		Surges—Time to Half Value	573		
Joint Use of Poles	746	Surges, Voltage—Frequency of on Transmission Lines	560		
Klydonograph	551	Surges—Wave Fronts of	561, 573		
Klydonograph—Use of	559, 560	Surges—Wave Shape of			
Kva—Base	295	Currents	570		
KV. T Factors	758	Voltages	561		
Lighting Circuits	770	Thunderstorm Days per Year	585		
Power Systems	772	Traveling Waves	523		
Lagging Reactive Power	291, 292	Wave Shape	561, 570, 573, 574		
Lamp Flicker—see Flicker		Wave Shape of Initial High			
Lattice Network for Current	531	Currents	573		
Lattice Network for Traveling Waves	530	Lightning Arresters	599, 623, 624, 632, 637		
Lead-Sheathed Cable, See Cable		Effect of Soil Resistivity on Discharge Currents	575		
Lighting Circuit		Effect of System Grounding on Discharge Currents	575		
Coordination Characteristics	770	Expulsion Type	622		
Wave Shape	770	Resistance Grounded Systems	651		
Lightning—Chap. 16	542	Ungrounded Systems	650		
Charge	567	Rating, Selection of	625		
Crest Magnitude	559, 564 to 567	Special, Characteristics of	641, 642		
Direct Strokes to Unshielded Substations	630, 631	Valve Type	623		
Discharges—Charge in	567	Lightning Performance of Typical Transmission Lines	587 to 592		
Frequency of Occurrence	556	Limiters	704, 715		
Ground Gradients	550	Line-Drop Compensator	697		
Hot and Cold	549	Line Losses	334		
Initial Leaders		Line Losses, Example	314, 335		
Low Objects	547	Line Trap	416, 417		
Stroke Discharge	547	Linear Coupler	355		
Tall Objects	551	Load Division, Secondary Network	707, 708		
Measuring Instruments	551	Load-Frequency Control	406		
Mechanism	546	Load Growth	694, 710		
Multiple Strokes	548, 563	Load to Transformer—Capacity, Ratio of	708		
Number of Strokes to Line	568	Loads			
Number of Surges Discharged by Arresters	569	Converting Kw and Kva to Admittance or Impedance	294		
Number of Surges in Line	560	Intermediate	323		
Performance of Lines		Representation in Single-Line Diagram	293		
588 to 590, 792 to 797		Representation in Stability Studies	441, 462, 464, 465, 471		
Phenomena	542	Representation of	293		
Polarity	543, 544, 567	Longitudinal Choke Coils	754, 756		
Protection—Coupling	582	Longitudinal Circuits	742		
Protection—Examples of Tower Footing Resistance	584	Longitudinal (-Circuit) Induction	743		
Protection Features of Lines		Loop Systems			
785 to 789, 792 to 797		Closed	297		
Protection, Transmission Lines—Direct Stroke Theory	578, 579	Sum of Angular Shifts not Zero	300		
Return Stroke		That do not close	298		
Low Objects	547	Loop Type			
Tall Objects	551	Distribution System	684		
Return Stroke Discharge	548	Subtransmission	669		
Stroke Discharge, Mechanism of	546	Loss			
Initial Leaders	547	Power Line Carrier			
Return Stroke	547	Channels	425 to 429		
Strokes—Multiple	548, 563	Synchronous Machines During Faults	176		
Strokes—Polarity	567	Transformers	101 to 103		
Strokes to Tall Buildings	551	Losses in Primary Network	693		
		Losses in Secondary Network	709		
		Losses of Transmission Lines			
		Long Lines	273, 278		
		Short Lines	271, 282, 286		
				Natural Frequency of Synchronous Machine	186

- | PAGE | | PAGE | | PAGE |
|------|---|--------------------|--|---|
| | Negative-Sequence Losses in Stability Studies..... | 442 | | Planning the Secondary Network..... |
| | Negative-Sequence Reactance of Synchronous Machines..... | 160 | | Polarity—Effect on Wave Attenuation..... |
| | Negative Sequence Vectors..... | 14 | | Poles, Joint Use of..... |
| | Network | | | Portable Substation..... |
| | Distribution Systems | | | Positive- and Negative-Sequence Impedance |
| | A-C..... | 689 | | Aerial Lines..... |
| | Buildings..... | 713 | | Cable..... |
| | D-C..... | 689 | | Cables in Parallel..... |
| | Industrial Plants..... | 715, 716 | | Cables in Parallel..... |
| | Low-Voltage..... | 689 | | Cables in Parallel..... |
| | Power Plants..... | 689, 702 | | Cables in Parallel..... |
| | Primary..... | 689 | | Cables in Parallel..... |
| | Secondary..... | 689, 698, 701 | | Cables in Parallel..... |
| | Equivalents..... | 305 | | Cables in Parallel..... |
| | Fault Representation in Stability Studies..... | 442 | | Cables in Parallel..... |
| | Linear..... | 301 | | Cables in Parallel..... |
| | Passive..... | 332 | | Cables in Parallel..... |
| | Passive Linear..... | 301 | | Cables in Parallel..... |
| | Protectors, Network | | | Cables in Parallel..... |
| | Relaying of..... | 689, 705 | | Cables in Parallel..... |
| | Reduction..... | 304 to 308 | | Cables in Parallel..... |
| | Reduction—Example..... | 317 | | Cables in Parallel..... |
| | Relaying..... | 689, 698, 705, 706 | | Cables in Parallel..... |
| | De-sensitizing Relay..... | 698, 706 | | Cables in Parallel..... |
| | Relays..... | 698, 705 | | Cables in Parallel..... |
| | Representation—Impedance Diagram..... | 290, 291 | | Cables in Parallel..... |
| | Representation—Single-Line Diagram..... | 290 | | Cables in Parallel..... |
| | Simplification in Stability Studies..... | 462, 466, 473, 478 | | Cables in Parallel..... |
| | Solution—See <i>Network Solution</i> | | | Cables in Parallel..... |
| | Star with Mutuals Converted to Star without Mutuals..... | 306 | | Cables in Parallel..... |
| | Transmission Type..... | 324 | | Cables in Parallel..... |
| | Network Calculator (See <i>AC Network Calculator</i>) | | | Cables in Parallel..... |
| | Network Calculator, Fault Calculations for Circuit-Breaker and Relay Application..... | 389, 457, 501 | | Cables in Parallel..... |
| | Network Calculator, Planning a Secondary Network..... | 710, 712 | | Cables in Parallel..... |
| | Network Solution | | | Cables in Parallel..... |
| | Alteration of Network..... | 321 | | Cables in Parallel..... |
| | By Circulating Currents..... | 311 | | Cables in Parallel..... |
| | By Determinants..... | 303 | | Cables in Parallel..... |
| | By Equations..... | 302 | | Cables in Parallel..... |
| | By Reduction..... | 305 | | Cables in Parallel..... |
| | Compensation Theorem..... | 301 | | Cables in Parallel..... |
| | Conversions in Admittance Form..... | 307 | | Cables in Parallel..... |
| | Conversion of Impedance | | | Cables in Parallel..... |
| | Forms..... | 305 to 307 | | Cables in Parallel..... |
| | Current Division..... | 305 to 308, 316 | | Cables in Parallel..... |
| | Equivalent Pi of Transmission System..... | 328 | | Cables in Parallel..... |
| | Equivalent T of Transmission System..... | 328 | | Cables in Parallel..... |
| | Example of Solution by Circulating Currents..... | 311 | | Cables in Parallel..... |
| | Example of Solution by Reduction..... | 308 | | Cables in Parallel..... |
| | Intermediate Loads..... | 323 | | Cables in Parallel..... |
| | Mesh Currents and Voltages..... | 302 | | Cables in Parallel..... |
| | Mesh Impedance..... | 302 | | Cables in Parallel..... |
| | Notation—in..... | 301 | | Cables in Parallel..... |
| | Power..... | 298 | | Cables in Parallel..... |
| | Reciprocal Theorem..... | 301 | | Cables in Parallel..... |
| | Reference Current and Voltage Directions..... | 301 | | Cables in Parallel..... |
| | Regulation by Self and Mutual Drops..... | 316, 318 | | Cables in Parallel..... |
| | Representation of Solution..... | 314 | | Cables in Parallel..... |
| | Representation of Solution—Method of Self and Mutual Drops..... | 314 | | Cables in Parallel..... |
| | Self and Mutual Drops—Example..... | 317 | | Cables in Parallel..... |
| | Single—and Multiple-Source System Having Shunt Branches other than Loads..... | 320 | | Cables in Parallel..... |
| | Single-Source System Without Shunt Branches other than Loads..... | 316 | | Cables in Parallel..... |
| | Star-to-Mesh Conversion..... | 307 | | Cables in Parallel..... |
| | Superposition Method..... | 301 | | Cables in Parallel..... |
| | Theorems (General)..... | 290 | | Cables in Parallel..... |
| | Network Solution (continued) | | | Cables in Parallel..... |
| | Thevenin's Theorem..... | 309 | | Cables in Parallel..... |
| | Transmission Type Network..... | 324 | | Cables in Parallel..... |
| | Network Supply—Station | | | Cables in Parallel..... |
| | Connections..... | 10 | | Cables in Parallel..... |
| | Networks, D-C..... | 667 | | Cables in Parallel..... |
| | Neutral Breaker..... | 660 | | Cables in Parallel..... |
| | Neutral Displacement..... | 658 | | Cables in Parallel..... |
| | Neutral Displacement on Four-Wire System..... | 664 | | Cables in Parallel..... |
| | Neutral Grounding Devices—Time Ratings..... | 660, 661 | | Cables in Parallel..... |
| | Neutral Impedance..... | 22 | | Cables in Parallel..... |
| | Neutral Impedance—Coordination of Power and Communications Systems..... | 747 | | Cables in Parallel..... |
| | Neutral Reactor Size..... | 646, 647, 652, 658 | | Cables in Parallel..... |
| | Neutral-Tuned Filter..... | 663 | | Cables in Parallel..... |
| | Neutralizing Transformers..... | 754 | | Cables in Parallel..... |
| | Neutralizing Wires..... | 754 | | Cables in Parallel..... |
| | Noise | | | Cables in Parallel..... |
| | Impulse..... | 413 | | Cables in Parallel..... |
| | Measurement on Power Lines..... | 414 | | Cables in Parallel..... |
| | Noise-Frequency Coordination of Power and Communication System | | | Cables in Parallel..... |
| | Chap. 23—Part III..... | 756 | | Cables in Parallel..... |
| | Coupling Factors..... | 776, 782 | | Cables in Parallel..... |
| | Transpositions..... | 776 | | Cables in Parallel..... |
| | Frequency-Weighting Curves..... | 757 | | Cables in Parallel..... |
| | Influence Factors of Power Systems | | | Cables in Parallel..... |
| | Balance..... | 759 | | Cables in Parallel..... |
| | Filters, Effects of..... | 772 to 776 | | Cables in Parallel..... |
| | Wave Shape of Apparatus | | | Cables in Parallel..... |
| | See Particular | | | Cables in Parallel..... |
| | Apparatus..... | 759 to 770 | | Cables in Parallel..... |
| | Wave Shape of Lighting Circuits..... | 770 | | Cables in Parallel..... |
| | Wave Shape of Power Systems..... | 771 | | Cables in Parallel..... |
| | Procedure..... | 756 | | Cables in Parallel..... |
| | Susceptiveness Factors of Communication Systems | | | Cables in Parallel..... |
| | Balance..... | 778 | | Cables in Parallel..... |
| | Circuit Type..... | 778 | | Cables in Parallel..... |
| | Frequency Response..... | 779 | | Cables in Parallel..... |
| | Power Level..... | 778 | | Cables in Parallel..... |
| | T.I.F. Factors and Curves..... | 756 | | Cables in Parallel..... |
| | Telephone Noise | | | Cables in Parallel..... |
| | Calculation..... | 780 | | Cables in Parallel..... |
| | Evaluation..... | 782 | | Cables in Parallel..... |
| | Oil Filled Cable, See <i>Cable</i> | | | Cables in Parallel..... |
| | Open Wires on Transmission Line..... | 25 | | Cables in Parallel..... |
| | Oscillations—Electromechanical..... | 456 | | Cables in Parallel..... |
| | See also <i>Stability—Power System</i> | | | Cables in Parallel..... |
| | Oscillograms—Traveling Waves..... | 537 | | Cables in Parallel..... |
| | Oscillograph—Crater Lamp..... | 554 | | Cables in Parallel..... |
| | Outages, Consumer..... | 693 | | Cables in Parallel..... |
| | Overcurrent Protection..... | 358 | | Cables in Parallel..... |
| | Overhead Conductors, | | | Cables in Parallel..... |
| | Characteristics of—Chapter 3 (See <i>Aerial Conductors</i>)..... | 32 | | Cables in Parallel..... |
| | Overhead Secondary Network..... | 707 | | Cables in Parallel..... |
| | Overvoltage..... | 626, 627 | | Cables in Parallel..... |
| | Parallel Conductors in Secondary Mains..... | 703 | | Cables in Parallel..... |
| | Peak Load of Power Systems..... | 675 | | Cables in Parallel..... |
| | Per Unit System..... | 163 | | Cables in Parallel..... |
| | Performance of Transmission Lines..... | 792 to 798 | | Cables in Parallel..... |
| | Petersen Coil..... | 643 | | Cables in Parallel..... |
| | Phase Balancers..... | 733 | | Cables in Parallel..... |
| | Phase Converter..... | 733 | | Cables in Parallel..... |
| | Phase Shift in Transformers..... | 297 | | Cables in Parallel..... |
| | Pi to T Conversion..... | 306 | | Cables in Parallel..... |
| | Pilot Exciter | | | Cables in Parallel..... |
| | Compound Wound..... | 216 | | Cables in Parallel..... |
| | Rototrol..... | 217, 229, 230, 231 | | Cables in Parallel..... |
| | Rototrol Buckboost..... | 230 | | Cables in Parallel..... |
| | Pilot Wire Relaying..... | 364 | | Cables in Parallel..... |
| | Pilot Wire Relaying Circuit | | | Cables in Parallel..... |
| | Protection Against | | | Cables in Parallel..... |
| | Induction..... | 754 to 756 | | Cables in Parallel..... |
| | See also <i>Low-Frequency Coordination</i> | | | Cables in Parallel..... |

	PAGE		PAGE		PAGE
Power Station—Bus Layouts	8 to 11	Reactance		Relay (continued)	
Power Systems		See Specific Apparatus, Line, or Cable		Overcurrent	689, 692, 698, 699, 701
Effect on Stability—Layout	482	Constants, Also See <i>Capacitive and Inductive Reactance</i>		Pilot Wire Relay, Type HCB	364
Largest in U.S.	790	Reactive Power		Protection of Synchronous	
Operation Effect on Stability	484	Capability of Generator	152	Machines	348
Oscillations, Electromechanical—		Sign Convention	291	Protector	753, 755, 756
See <i>Stability, System Oscillations</i>		Reactors		Reclosing	376, 691, 692, 698, 699
Output and Peak Load	790	Application	133, 134	Settings, Fault Current Basis for	391
Stability—See <i>Stability, Power Systems</i>		Bus Sectionalizing	9	Single-Phase Switching	491
Stability Features of	785	Cost	135	Stability—Quick Breaker	
Statistical Data	785	Dry-Type	134	Reclosure	438, 439
Power Transmission—General Con-		In Spot Networks	714	Stability—Quick Fault Clearing	
siderations—Chap. I	1	Installation	134	464, 470, 477, 490 to 492	
Primary Feeders		Oil Immersed	134, 135	Symbols	358
Interconnected	689, 714	Rating, Determining	134, 135	Relay Elements	
Interlacing	690, 694, 700, 701, 708, 711	Short-Circuit Current	133, 134	Auxiliary Circuits	348
Primary	689, 690, 692, 694, 700	Size for Generator Neutral	658	Balance Beam	345, 348
Secondary		Standards	134, 135	Induction	343 to 347
Network	702, 706 to 709, 711	Real and Reactive Power Flow—		Inductor Loop	344, 348
Primary Network	689	Examples of Calculation by Circle		Instantaneous	343, 344
Circulating Currents	697	Diagrams	333 to 341	Polar	345
Consumer Outages	693	Reciprocal Theorem—for Network		Relaying	
Desensitizing Relay	698	Solution	301	Application Chart, Relay	350, 351
Design	699	Reclosing	376	Application Factors	343
Economics	694	Primary Feeders	679, 680, 694	Back-Up Protection	367
Feeder Breaker	698	Primary-Network Subtransmission		Bus Protection	354
Flexibility for Load Growth	693, 696	Circuits	701	Carrier Pilot System	361
Interlacing Supply		Single Pole	491 to 493	Connections, Three-Phase	370, 371
Circuits	690, 694, 700, 701	Tie Feeders	692, 698	Current-Voltage Product	
Intersection Bus Faults	692	Reclosing Breakers—Stability,		Relaying	366
Losses	693	Effect on	437, 438, 439, 490	Differential	348
Mid-Tie Breakers	699	Recovery Voltage Coordination with		Directional, for Bus Protection	356
Modifications	701	De-ion Protector Tube		Double-Winding Generators	349
Operation of System	691, 692	Characteristics	504, 505	Effective Grounding	649, 660
Overcurrent Relays	689, 698, 699, 701	Recovery Voltage		Fault Bus Scheme	356
Relaying	698	Data on Typical Systems	505 to 507	Fault Voltage and Currents	369 to 371
Reversed Reactance Compensation	697	Distribution System	508	Feeder	660
Subtransmission Circuits		Theory	504, 505	Field Protection of Generators	
.	690, 692, 694, 700	Rectifier		General Considerations	349, 352
Switchgear	698	Filters	774 to 776	Generators, A-C	348, 660
Transformer	689 to 691, 696	Internal Inductance of	769	Ground	365
Unit	690, 691, 694, 696, 699	Wave Shape	766 to 770	Impedance, for Bus Protection	355
Completely-Self-Protected		Reflected Waves	526	Impedance, for Transmission	
Transformer	696	Due to Shunt Networks	530	Lines	359, 360
Switchgear	698	For Different Line Conditions	533	Impedance Measurements	372
Transformer	696	Reflections—Traveling Waves	526	Impedance, Modified	360
Primary Switch		Regulating Transformers		Incorrect Operation	343
Primary Network	696	Equivalent Circuits	803	Industrial Interconnections	368
Secondary Network	705, 715	Phase Shift	297	Linear Coupler Scheme	355
Propagation Constant	409	Relaying	353	Microwave	364
Protective Devices		Regulation	313	Motor Protection	368
Application of	625	Distribution Feeder	681	Multi-Restraint Relay	355
Characteristics of	621	Distribution Transformers	683	Negative-Sequence Directional	366
Coordination of, with Apparatus		Example	313, 316, 319	Out-of-Step Protection	369
Insulation	627, 628	Secondaries	683	Overcurrent, for Bus Protection	354
Distribution Transformers	636	Self and Mutual Drops	316, 318	Overcurrent Ground	366
Distribution Transformers,		Services	683	Overcurrent Protection	358
Methods of Connecting for	632, 633	Synchronous Machines	151, 152	Pilot-Wire	364
Lightning Arresters		Regulation, Transmission Lines		Power House Auxiliary	368
.	622, 623, 632, 637, 641, 642	Long Lines	271, 288	Power-Line Carrier	405
Location and Connection of	628, 629	Short Lines (See Also <i>Voltage</i>		Protective Zone	342
Protector Tubes	621, 632, 636	Regulators (See Also <i>Voltage</i>		Quantities, how obtained	369
Rod Gaps	615, 621, 632, 636	<i>Regulators</i>)		Reactance	366
Protective Ratio	621, 624	Appendix	803	Regulating Transformers	353
Protector Tube (De-ion Tubes)		Approximate Impedance Data	395	Relay Operations	343
.	622, 632, 636	Distribution Voltage	670, 677, 681	Remote Trip	354
Applied to Old Construction	605	Quick Response	479, 487, 488	Series Capacitors	261
Characteristics	601, 602	Relay (See Also <i>Relaying</i>)		Shunt Capacitors	246
Correction Operation	605	Application Chart	350, 351	Symbols	358
Effect of Erosion	602, 603	Application, Fault		Testing and Maintenance	369
Isolated-Neutral System	605	Calculations	389, 395	Three-Terminal Lines	369
Mounting	603	Carrier, HKB	362	Three-Winding Transformers	353
On Grounded Systems	603, 604	Desensitizing	698, 706	Transmission Lines, Protection of	355
Recovery Voltage	600, 601	Elements	343 to 348	Typical System, Protection of	342, 357
Selection of	603, 604	Failure	343	Repeat Coil	778
System Recovery Voltage	505	HCB Pilot Wire	364	Reserve Transformer Capacity	
Theory of Operation	600	High-Speed, Fault Current Basis		693, 694, 700, 707, 708, 714, 715
Typical Application	605, 606, 608	for Preliminary Settings	391	Reversed Reactance Compensation	697
Voltage Rating	602	Impedance Type, High		Residual-Component T.I.F.	
Proximity Effect, Cable	68, 70, 71	Speed	360, 361	Machine Guarantee	760
Pull-Out Power	446 to 452	Impedance Type, Modified	360	Machine Measurement	758, 772
Radial Systems—Phase Shifts in	297	Impedance Type, Normal Speed	359	System Measurement	772
Radial-Type Distribution System	667	Induction Type, Characteristics of	359	Residual (Voltage or Current), Relation	
		Multi-Restraint	355	to Zero-Sequence	748

	PAGE		PAGE
Residual Voltages of Ungrounded Power Systems.....	751	Self Impedance.....	332
Resistance		Sensitive-Tripping Characteristic of Network Relays.....	698, 706
Armature.....	176, 189	Sequence Impedances of Lines, Transformers, and Rotating Machinery... 22	
Conductors.....	33, 34	See Also Particular Apparatus	
Grounding.....	644	Sequence Networks.....	21
Negative Sequence of Machines.....	161, 189	Connections.....	22
Solid Conductor to Surges.....	538	Direction of Current Flow.....	22
Synchronous Machines.....	182, 189	Distribution Factors.....	22
Temperature Effect.....	33	Equations.....	25
Zero Sequence.....	41 to 45	Example of Fault Calculation.....	29 to 31
Resistivity of Earth.....	595, 596, 747	Fault Representation.....	442, 462, 466
Resonant-Grounded Systems.....	647, 648	Multiple Unbalances.....	26
Resonant Shunts.....	766, 772 to 776	Shunt and Series Unbalances.....	24
Response—Typical Exciter (See <i>Excitation Systems</i>).....	785	Sequence-Segregating Filters.....	373 to 376
Reversed Reactance Compensation.....	697	Sequence Voltages and Currents—	
Ring—Subtransmission.....	669	Phase Shift in Transformers.....	297
Rms A-C Component of Fault Current.....	389	Series Capacitors.....	183
Rod Gaps.....	615 to 619, 621, 636	Application Considerations.....	256, 257
Flashover Characteristics of.....	615 to 619	Arc Furnace Correction.....	263
Rod Grounding.....	593, 594	Arrangement in Banks.....	259
Rotating Machines, Surge Protection, Choke Coil and Capacitor Method.....	640	Construction.....	256
Rototrol.....	208	Distribution Systems.....	682
See <i>Main Exciter Rototrol</i>		Ferro-Resonance.....	262
Salient-Pole Machines—Effect on Stability.....	444, 445, 453	Hunting of Motors.....	262
Saturation Curves for Typical Synchronous Machines.....	147	Lamp Flicker.....	257, 263
Saturation Factors for Synchronous Machines.....	187	Location.....	259
Secondaries—Distribution.....	666, 667, 682	Method of Improving Stability.....	482
Secondary Circuits, Surge Protection for.....	635	Power-Factor Improvement.....	258
Secondary Faults, Burning Clear.....	702 to 704, 707, 712, 714, 715	Power Transfer.....	257
Secondary Loop.....	715	Progress in Application.....	263, 264
Secondary Mains.....	702, 707, 708, 711, 714, 715	Protection	
Clearing Faults.....	702 to 704, 707, 712, 714, 715	Dielectric Failure.....	260, 261
Fault Currents.....	704, 707, 712, 714, 715	Fault.....	259, 260
Interconnected Grid.....	689, 702, 710	Overload.....	260
Limiters.....	704, 715	Radial Feeders, Effect on.....	256, 257
Parallel Conductors.....	703, 715	Rating.....	258
Planning.....	711	Reactance.....	294
Tie Points.....	703	Reduction of Flicker.....	735 to 737
Secondary Network		Relaying.....	261
Desensitizing Relay.....	706	Sub-synchronous Resonance.....	261, 262
Economics.....	709	Ten Thousand Kvar Installation.....	263
Fault Currents.....	704, 707, 712, 714, 715	Tie Feeders, Effects on.....	257
Flexibility for Load Growth.....	710	Sheath Currents, Cable, Effect of.....	71
For Power Plants.....	714, 715	Shell Form Transformers.....	104, 105
In Buildings.....	713	Shielding	
In Industrial Plants.....	715	Action.....	746, 752, 776
In Small Towns.....	715	Cable Sheaths.....	752, 753
Interlacing of Supply Circuits.....	708, 711	Conductors.....	752
Limiters.....	704, 715	Station for Direct Strokes.....	630, 631
Load Division.....	707, 708	Short Circuit Calculations.....	390
Load to Transformers—Capacity Ratio.....	708	Calculations for Circuit Breaker and Relay Application.....	389 to 395
Losses.....	709	Current, Effect of Location on System.....	390
Operation of System.....	707	Currents, Simplified Procedure for Calculating.....	389
Overhead.....	707	Induction Motor.....	191
Planning.....	710	Synchronous Machines	
Primary Feeder Faults.....	707	Change in Excitation.....	165 to 172
Primary Feeders.....	706 to 708, 711	Three Phase.....	152 to 158, 166, 167
Secondary Faults.....	702 to 704, 712, 714, 715	Unbalanced.....	158
Secondary Mains.....	702, 707, 711	Without Damper	
Special Applications.....	713	Windings.....	177 to 181
Subtransmission Circuits.....	706	Short-Circuit Ratio.....	149, 150, 448, 449
Transformer.....	702, 704, 706 to 708, 711, 712	Shunt-Capacitive Reactance	
Secondary—Network Unit.....	702, 704, 712, 714	Formulas.....	47
High-Voltage Switch.....	705, 715	Overhead Lines.....	46, 47
Protector.....	689, 702, 705, 706	Shunt Capacitors.....	737
Transformer.....	702, 704, 706 to 708, 711, 712	Automatic Control.....	250
Sectionalizing Breaker.....	687	Construction.....	233
Selector Breaker.....	10	Damage Due to Fault Current.....	243
		Discharge Currents.....	253
		Distribution Circuits.....	241, 242, 681
		Economics.....	235, 255, 256
		Effect on System.....	233
		Factory Tests.....	238
		Failure Rate.....	234
		Fault Current Damage.....	247
		Fault Current in Large Banks.....	244, 245
		Filters, Shunts and Wave Traps, Use in.....	766 to 772
		Fundamental Effects.....	234 to 236
		Fuses for.....	243
		Shunt Capacitors (continued)	
		Harmonic Voltages.....	252, 253
		High-Voltage Banks.....	242
		History.....	233
		Induction Motor Installation.....	241
		Inductive Coordination.....	253, 254
		Industrial Plant Application	
		Effect of Rates.....	239, 240
		Location.....	238, 239
		Inrush Current.....	250, 251
		Loss Reduction by Use of.....	235, 236
		Overvoltage.....	243
		Overvoltage During Faults.....	244
		Overvoltage on.....	238
		Portable.....	254
		Power Factor Correction.....	234, 235
		Protection	
		Delta Banks.....	245, 246
		Fuse Characteristics.....	248 to 250
		Group Fusing.....	247, 248
		Individual Fusing.....	248, 249
		Large Banks.....	243
		Wye Grounded.....	245, 246
		Wye Ungrounded Banks.....	245, 246
		Reactance.....	294
		Relaying for Faults.....	246
		Self Excitation of Induction Motors.....	240, 241
		Size.....	234
		Stability, Power System.....	254
		Standard Ratings.....	238
		Stored Energy.....	253
		Surge Protection.....	254, 255
		Switching.....	387
		Switching of Large Banks.....	242
		Synchronous Condensers	
		versus.....	255, 256
		Synchronous Condensers with.....	256
		Voltage Drop Reduced by.....	236, 237
		Voltage During Switching.....	252
		Voltages on Banks with Faulty Capacitors.....	244, 245
		Wave Shape, Effect on.....	778
		Signal System.....	745
		Signal-to-Noise Ratio, Power-Line Carrier.....	431, 432
		Simplex Communication System	
		Automatic.....	403
		Single Frequency.....	402
		Single-Line Diagram—Symbols.....	293
		Single Sideband Modulation.....	408, 409
		Skin Effect	
		Cable.....	68
		Traveling Waves.....	524
		Wires.....	34
		Sodium Lamps	
		Coordination Characteristics.....	771
		Wave Shape.....	771
		Span Lengths, Typical Practice.....	588 to 590, 792 to 797
		Spark Gaps for Measuring Surge Voltages.....	551
		Spot Network.....	714
		Balancing Transformer.....	714
		Circulating Currents.....	714
		Reactors.....	714
		Stability Features of Typical Lines.....	785
		Stability, Power-System (Chap. 13).....	433
		Acceleration.....	438, 439, 458 to 460
		A-C Network Calculator.....	457 to 460
		Circuit Elements.....	475
		Machine Representation.....	172, 175
		Angle-Time or Swing Curves.....	457, 463, 470
		Arc-Suppression Measures.....	494
		Armature Resistance.....	176
		Bussing Arrangement, Effects of.....	482
		Calculation, Methods of	
		Analytical.....	440, 460, 463, 474
		Examples.....	460
		Short-Cut.....	470, 476
		Step-by-Step.....	458 to 460, 463, 468
		Circuit Breakers and Relays	
		Quick-Fault Clearing.....	463, 470, 477, 489, 490

- | | PAGE | | PAGE | | PAGE |
|--|------------------------------|--|------------------------------|--|---------------|
| Stability, Power-System (continued) | | Stability Power-System (continued) | | Supervisory-Control Circuit—See | |
| Quick Reclosure | 438, 439, 490 | Synchronous Machine Pull-Out (cont.) | | Also <i>Low-Frequency Coordination</i> | |
| Single-Phase Switching | 491 | Synchronous-Reactance | | Protection Against | |
| Criterion of | 438, 435 | Method | 448 | Induction | 753 to 756 |
| Critical Point in System Oscillation | 436 | Synchronous Machine | | Supply Line Faults | 692, 707 |
| Critical Load | 436 | Representation | 172, 175 | Surge | |
| Damper Windings, Effect of | 455, 486 | Internal Voltage | 446, 454 | Admittance | 524 |
| Definitions | 435 to 437, 454 | Steady State | 444 to 453 | Capacitance | 524 |
| Dynamic Stability | 195, 455 | Transient | 453, 460, 464 | Crest Ammeter | 553 |
| Equal-Area Criteria | 457 | Synchronous Machines | | Front Recorder | 554 |
| Equivalent Single-Machine | | Damper Windings | 455, 486 | Fusible Wires for Measuring | 553 |
| Constants | 450 | Inertia | 457, 486, 491 | Impedance | 280, 281, 524 |
| Excitation System, Effects of | | Internal Voltage | 446, 488 | Impedance Loading | 280, 281, 479 |
| | 195, 455, 487 to 489 | Loss of Field | 436 | Impedance—Self and Mutual | 532 |
| Faults | | Short-Circuit Ratio | 485 | Impedance—Several Conductors | |
| Arc-Suppression Measures | 494 | Transient Reactance | | in Parallel | 533 |
| Effect of Duration | | | 453, 464, 465, 485 | Inductance | 524 |
| | 438, 482, 483, 491, 492 | Two Winding | 487 | Integrator | 555 |
| Representation in Stability | | System Oscillations | | Paper Gaps for Measuring | 553 |
| Studies | 442, 466 | | 456 to 460, 435 to 438 | Protection—Distribution Trans- | |
| Flashover Prevention Measures | 494 | Transient Calculations | | formers, General Considerations | 632 |
| Generator Characteristics—See | | A-C Network Calculator | 476 | Interconnection | |
| <i>Synchronous Machines</i> | | Transient Limit | 436, 440 | Method | 632, 633 |
| Governors, Effects of | 456 | Transient Stability | | Protective Devices for | 636 |
| Grounding, Effects of | 484 | | 436, 460, 461, 465, 471, 477 | Separate Connection | |
| Hunting | 455 | Faults with Circuit Isolation | | Method | 632, 633 |
| Impedance Elements | | | 438, 463, 464, 466, 471, 482 | Three-Point Connection | |
| | 440, 462, 464, 466, 471, 482 | Faults with Reclosure | 439, 489, 490 | Method | 634 |
| Impedance Terminal Equipment | 481 | Illustration of Features Affected | | Protection—High Voltage Equip- | |
| Inertia Constants | 175, 457, 458 | by Fault | 454, 482, 489, 490 | ment, Considerations Applying | |
| Equivalent Single-Machine | 457, 458 | Load Increases | 436 | to | 632 |
| Initial Operating Conditions | 442 | Switching | 437 | Protection—Rotating | |
| Limit, Definition of | 435 | Transmission Line Loading | 479 | Machines | 638, 639 |
| Load Increases | 436 | Transmission Lines Permissible | | Protection—Secondary Circuits | 635 |
| Load Representation | | Loading Curve | 481 | Protection—Shunt | |
| | 441, 462, 464, 466, 471 | Two-Machine Systems | | Capacitors | 254, 255 |
| Loss in Synchronous Machines | | | 434 to 439, 463, 470 | Spark Gaps for Measuring | 553 |
| During Faults | 176 | Two-Reaction Method | 445, 453, 476 | Switching—See <i>Switching Surges</i> | |
| Loss Representation, Negative | | Unidirectional Component of | | Testing | 612 |
| Sequence | 442 | Short-Circuit Current | 176 | Bushings | 620 |
| Low-Frequency Transmission | 494 | Voltage Regulators | 455, 487, 488 | Chopped Wave | 619 |
| Machine Representation | 175 | Stability Studies, Equal-Area Criteria in | | Testing Atmospheric Conditions, | |
| Mechanical Analogy | 439 | | 437 to 439, 457 | Effect of | 614 |
| Methods of Improving | 482 to 494 | Star-Delta Conversion | 17, 306 | Testing Equipment | 613 |
| Metropolitan-Type Systems | 476, 490 | Star-Delta Transformations of Voltage | | Testing—Rod Gaps and | |
| Multi-Machine Systems | 473, 476 | and Current | 19 | Insulation, Flashover | |
| Negative-Sequence Resistance | 176 | Starters for Motors | 738 | Characteristics of | 615 to 619 |
| Network Simplification | | Steady-State Performance of Systems | | Testing Transformers, Standard | |
| | 462, 466, 473, 478 | Including Methods of Network | | Impulse Tests for | 619, 620 |
| Oscillation, Electromechanical | | Solution | 290 | Testing Volt-Time Curves | 614 |
| Calculation | 456 to 461, 463, 468 | Steady-State Stability—See <i>Stability,</i> | | Testing Wave Shape | 613 |
| Equal-Area Criteria | 436 to 438 | <i>Power System</i> | | Testing Voltage | 523 |
| Hunting | 455 | Steam Power | 2 | Voltage Theory | 511, 512 |
| Natural Frequency | 456 | Steam Pressures | 3 | Surge Impedance | 280, 281 |
| Power-Angle Diagrams | | Steel Conductors | 34 | Surge Impedance Loading | 479 |
| Complex System | 467 | Steel Ground Wires—Characteristic | | Typical Values | 280, 281 |
| Simple System | 434 to 439, 454 | Curves | 34 | Swing Curves, See <i>Angle-Time Curves</i> | |
| Power-Circle Diagram | 434, 442 | Steel Rolling Mill—Power | | Switching Stations—Effect on | |
| Determination of Initial Loads | 442 | Demand | 729, 730 | Stability | 482 |
| Power-System Layout | 482 | Step-by-Step Methods in Stability | | Switching Surges | 627 |
| Power-System Operation | 484 | Studies | 458 to 460, 463, 468 | Field Test Data | 517 |
| Prime-Mover Inertia | 457, 486 | Step-Type Voltage Regulators | 395 | Laboratory Test Data | 513 to 516 |
| Reclosing Breakers | 438, 490 | Stored Energy of Rotating | | Theory | 511, 512 |
| Saliency Effects in | | Machines | 437, 457, 458 | Symbols | |
| Machines | 444, 445, 453 | Structural Coordination | 746 | Equipment | 291 |
| Saturation Effects in | | Substations | | Relay | 358 |
| Machines | 446, 454 | Direct Stroke Protection for | 630, 631 | Windings | 293 |
| Series Capacitors | 257, 482 | Distribution | 666, 667, 669 | Symmetrical Components—Chap. 2 | 12 |
| Short-Cut Methods | 470, 476 | Portable | 116 | Admittances | 17 |
| Shunt Loads | 441 | Primary Network | | Cable Circuits | 68, 70 to 78 |
| Single-Machine Systems | | | 690, 694, 696, 699, 701 | Degrees of Freedom | 14 |
| | 457 to 460, 463 | Unit Type | 675 | Delta Currents | 16 |
| Single-Phase Switching | 491 | Subtransient Reactance of | | Delta Voltages | 15 |
| Single-Pole Reclosing | 491 to 493 | Synchronous Machines | 154 | Direction of Current Flow | 22 |
| Single-Tie Line | 492, 493 | Subtransmission Circuits | 666 to 668 | Example of Fault Calculation 27 to 29 | |
| Steady-State Stability | 436, 444 | Grid | 669 | Fundamental Principle | 12 |
| Illustration of Factors Affecting | | Interlacing | 690, 694, 700, 701, 708, 711 | Harmonics, Sequence of | 758 |
| | 434, 443, 454, 473, 486, 489 | Loop | 669 | History | 12 |
| Step-by-Step Procedure | 453, 463, 468 | Radial | 668 | Line and Delta Currents | 19 |
| Switching Operation | 437 | Sudden Application of Load | | Multiple Unbalances | 26, 27 |
| Switching Stations, Effect of | 482 | Saturated Machines | 169 | Mutual Coupling Between | |
| Synchronous Machine Pull-Out | | Unsaturated Machines | 168, 169 | Sequences | 15 |
| Air-Gap Method | 451 | Superposition Theorem—for Network | | Mutual Impedances | 17 |
| Potier-Voltage Method | 446 | Solution | 301 | | |
| Short-Circuit-Ratio Method | 448 | Supervisory Control | 407, 430 to 432 | | |

	PAGE		PAGE		PAGE
Symmetrical Components (continued)		Synchronous Machines (continued)		Synchronous Machines (continued)	
Positive- and Negative-Sequence Impedance		Grounding—Unit System	661 to 663	T.I.F. Guarantees	760
Aerial Lines	33 to 40	Harmonics and Grounding	658	T.I.F. Measurements	760, 772
Cables	67, 72 to 74, 79 to 84	High-Speed Excitation Effect on Terminal Voltage	171, 172	Time Constants	188, 189
Cables in Parallel	84 to 94	Hunting of	262, 455	Armature Short Circuit	155, 159
Relationship of Line-to-Line and Line-to-Neutral Voltages	18	Hydrogen Cooling	3	Open-Circuit Transient	154
Resolution of Unbalanced Three-Phase Currents	15	Inertia Constants	457, 458, 486	Short-Circuit Transient	154
Resolution of Unbalanced Three-Phase Voltage into Positive-, Negative- and Zero-Sequence Components	14, 15	Internal Voltages in Stability Studies	446, 461, 488	Subtransient	155
Sequence Filters	373 to 376	Mechanical Strength of Windings	659	Transient Overvoltages	660
Sequence Networks	21	Natural Frequency (Electromechanical)	186, 456	Two-Winding Generators	487
Shunt and Series Unbalances	22	Negative-Sequence Resistance	161	Typical Constants	187 to 190
Three-Phase Power	20	Power Loss During Faults	176	Unbalanced Short Circuit	158, 177
Unbalance Factor	15	Power Output		Unsymmetrical Short-Circuits Under Capacitive Loading	179
Used with Network Calculator	13	Connected to Infinite Bus	164	Voltage Drop with High-Speed Excitation	171, 172
Vector Diagram	15	Loaded with Resistance and Reactance	164	Voltage, Internal (e_d)	149
Vector Operator "a"	13	Pull Out Power	444 to 452	Wave Shape	759, 772
Voltage Drops for Both Self- and Mutual-Impedances	17	Comparison of Methods of Calculation	452	Zero Power Factor Regulation Curve	150, 151
Zero-Sequence Impedance		Estimating Curves	452, 453	Synchronous Motor	
Aerial Lines	41 to 45	Reactance		Characteristic for Rapid and Slow Load Changes	725
Cable	67, 74 to 77, 79 to 84	Adjusted Synchronous	151	Light Flicker	724
Synchronous		Armature	147	Synchronous Reactance—See <i>Synchronous Machines</i>	
Machines	163, 188, 189	Armature Leakage	146	System Grounding—Chap. 19—See <i>Grounded Systems</i>	643
Transformers	138, 139	Effect of Dampers	182	System Oscillation—See <i>Stability—Power System</i>	
Synchronizing Bus Arrangement	9, 656	Negative-Sequence	155, 159, 160	T to Pi Conversion	306
Synchronous Condenser		Negative-Sequence, Method of Test	162	Tap Changing Mechanisms	
Constants	183	Potier	150, 189, 446	UNR	121
Cost	190	Steady-State Stability	443	URS	122
Current Limiting in	224	Subtransient	154, 187 to 189	UT	121
Effect on Flicker	734, 735	Summary Table	189	Tap Changing Under Load	121, 122, 696
Losses	255	Synchronous	147, 189, 448	Telegraph Circuits, Cross Fire in	741
Shunt Capacitors versus	255, 256	Synchronous—Determination	148	Telegraph Systems—See also <i>Low-Frequency Coordination</i>	
Shunt Capacitors with	256	Synchronous—Direct Axis	149	Coordination with Power Systems	741, 745, 777
Synchronous Converters, Wave Shape	761, 772	Synchronous—Quadrature Axis	149, 188, 189	Telemetering	430 to 432
Synchronous Generator—See <i>Synchronous Machines</i>		Transient	153, 187 to 189	Impulse Duration vs. Impulse Rate	405
Synchronous Machines		Transient Stability	453, 476, 485	Power-Line Carrier	405, 406
Angle, Internal	148, 149	Zero-Sequence	163, 188, 189	Telephone Circuit	
Capacitance to Ground	185, 186	Reactance Grounding	520	Balance of	745
Change in Excitation	165, 172	Reactive Power Capacity	152	Crosstalk in	741
Effect Upon Short Circuit	169, 170	Regulation	151, 152	Frequency Response of	779
Graphical Method of Determining	171	Relay Protection of	348	Party-Line Ringers, Effect on Balance of	745
Machine and Infinite Bus	168	Relaying	660	Power Level of	778
Resistance-Reactance Load	169 to 171	Double-Winding Machines	349	Protector Action, Effect on Balance of	753
Condenser		Resistance		Ringers, Party Line	778, 779
Constants	183	Equivalent, During Faults	176, 177	Sensitivity of	778
Cost	190	Negative-Sequence Method of Test	160, 162	Telephone Influence Factor—See Also <i>I.T. and KV.T. Factors, Telephone Interference Factor</i>	757
Effect on Flicker	734, 735	Positive Sequence	165	Lighting Circuits	770
Constants for Stability		Resistance Grounding	519	Telephone Interference Factor—See Also <i>I.T. and KV.T. Factors</i>	757
Problems	172 to 175	Saliency Effects in Stability	444, 445, 476	Machines	760, 772
Armature Resistance	176	Saturation	149, 150, 187	System Wave-Shape Survey	771, 772
Inertia Constant	175, 189, 190	Saturation Curves	147	Telephone Noise	780
Network Calculator Studies	175	Saturation Effects	446, 454	Calculation	780
Representation of Machine	175	Self-Excitation	183	Decibel Scale	781
Constants—Summary Table	189	Short-Circuit Ratio	149, 150, 448, 449	Evaluation	782
Converters—Wave Shape	760, 772	Short-Circuit Ratio Curves	190	Longitudinal (-Circuit Component)	744, 780, 781
Cost	190	Short Circuits	152, 158, 176 to 181	Metallic (-Circuit Component)	744, 780, 781
Damper Windings—See <i>Damper Windings</i>		Sizes	3	Reference Level	781
D-C Component of Armature Current	155	Standard Turbine Generators	3	Telephone Systems	
Deviation Factor	760	Steady-State Performance		Low-Frequency Coordination with Power Systems	
Drop in Terminal Voltage with Sudden Application of Load	172	Cylindrical Rotor	146	Cable	753
Excitation, High Speed Effect on Terminal Voltage	171, 172	Salient-Pole	148	Induced Voltage	
Field Protection	349	Saturation	149	Calculation	746 to 756
First Turbo-Unit in U.S.	2	Steady-State Stability		Protection, Standard	753
Flicker Due to Generators	721	Air-Gap Method	451	Special Protective Measures	753 to 756
Flicker Due to Motors	723, 725	Estimating Curves	452, 453	Noise-Frequency Coordination with Power Systems	
"Follow-Up Method"	167	Potier-Voltage Method	446	Balance	778
Grounding	655, 656	Short-Circuit-Ratio Method	448		
Grounding—Surge Protection	659	Synchronous-Reactance Method	448		
Grounding—Transient Voltages	517 to 521	Sub-Synchronous Resonance	261		
		Sudden Application of Load	168 to 170		
		Surge Protection	638, 639, 659		
		Synchronous Condenser Losses	255		
		Three-Phase Short Circuit	152		
		Effect of External Impedance	156		
		From Loaded Condition	156 to 158		
		Salient-Pole Machine	158		

	PAGE		PAGE		PAGE
Telephone Systems (continued)		Transformers (continued)		Transformers (continued)	
Noise-Frequency Coordination with		Cooling	105, 106	Relay Protection for	352
Power Systems (continued)		Coordination, Effects on	761	Remote Trip for Faults	354
Frequency Response	779	Core Form	104, 105	Resistance-Grounded Systems	651
Noise Calculation	780	Cost	131 to 133	Secondary Network	704, 706
Noise Evaluation	782	Derivation of Equivalent		Sequence Equivalent Circuits	138, 139
Power Level	778	Circuits	139, 140	Shell Form	104, 105
Sensitivity	778	Dielectric Tests	107	Short-Circuit Currents	109
Type of Circuit	779	Differential Protection—Phase		Short-Time Overloads	114
Power-Company		Shifts	297, 352	Single Phase Versus Three Phase	105
Noise Levels	781	Distribution	666, 667, 682	Star Delta, Equivalent Circuit	140, 141
Power Line	755	Distribution CSP	637, 638	Star-Delta Transformations	19, 20
Protective Scheme	752 to 756	Distribution, Protective Devices		Step-by-Step Temperature	
Transpositions	776	for	636	Calculation	112
Temperature—Effect on Resistance	33	Distribution, Surge Protection of	632	Tap Changing Under Load	121, 122
Tertiary Windings in Transformers—		Eddy Current Loss	126	Telephone Interference	129, 130
Effects on Third Harmonics	664	Effect on Transmission Line		Temperature	109 to 112
Thevenin's Theorem	309	Performance	288	Temperature During Variable Load	112
Three-Phase Power	20	Efficiency	101 to 104	Temperature Standards	109
Three-Phase Voltages—Symmetrical		Efficiency Chart	102	Temperature—Time Curves	109 to 112
Components of	14	Efficiency, Typical Values	103, 104	Theory	96 to 98
Three-Point Protection for Distribu-		Equivalent Circuits	97, 98, 799 to 808	Three Phase Versus Single Phase	105
tion Transformers	634	Four Winding	137	Three Winding	
Three-Wire System—Grounding	663	Three Winding	136 to 138	Impedance	99
Thunderclouds		Two Winding	97	Relaying	353
Charge and Field Distribution	545	Estimating Inrush Current	128	Ungrounded Systems	651
Charge Formation in	542	Estimating Prices	131 to 133	Vector Diagram	98
Electric Gradients	546, 550	Exciting Current	124 to 130	Water Cooled	106, 133
Rate of Charge Accumulation in	545	Harmonic Content	126	Zero-Sequence Impedance	138, 139
Simpson's Theory of Charge		Suppression of Third-Harmonic		Zig-Zag Grounding	120, 653
Formation	543	Component	129, 130	Transient Reactance of Synchronous	
Wilson's Theory of Charge		Typical Values	126	Machines	153
Formation	542	Variation with Terminal Voltage	11	Use in Stability Studies	453, 485
Thunderstorm		Ferro-Resonance	262	Transient Recording Apparatus	433
Cloud Heights	545	First A-C System	1	Transient Stability—See <i>Stability—</i>	
Frequencies	556	Force Cooled	105, 106, 133	<i>Power System</i>	
Isokeraunic Charts	557, 558	Forced Air Cooled	106, 133	Transient Studies	
Tie Feeders	689, 692, 699, 700	Forced Oil Cooled	106	A-C Network Calculator	502, 504
Breakers	691, 692, 698	Four Winding	137, 138	Analog Computer	503, 519
Fault	691, 692, 698, 699	Grounding Transformers	120, 121	Transient Voltages—See <i>Arcing</i>	
Mid-Tie Breaker	709	Guides for Loading	112 to 115	<i>Grounds and Switching Surges</i>	
Overcurrent Relaying	689, 698, 699, 701	Harmonics, Effects of	761	Transmission	
Tie Lines, Transient Stability of		Hot-Spot Temperature	111	High Voltage D-C	494
Typical	492	Hottest-Spot Copper Gradient	113	High Voltage, Low Frequency	
T.I.F. Balanced	758	Hysteresis Losses	126	A-C	494
Machine Guarantee	760	Ideal	574	History	1
Machine Measurement	758, 771, 772	Impedance	98, 100, 799	Liability	5
System Measurement	772	Impedance, Typical Values	99	Purpose of	6
T.I.F. Meters	758	Impulse Testing	107, 108	Supply Schemes	10, 11
Time Constants	188	Impulse Tests, Standard	619, 620	Type Networks—Conversion	
Armature Short-Circuit	155, 159	Induced Potential Tests	107, 108	Formulas	327
Induction Motor	193	Insulation Classes	108	Transmission Line	
Open-Circuit Transient	154, 188	Insulation, Impulse Characteristics		Application of Estimating and	
Short-Circuit Transient	154, 159	of	618, 619	Performance Curves	586, 587
Subtransient	155	Iron Losses	102, 103	Arcing Rings on Insulators	596
Time Over-Current Relays, Basis for		Lightning Protection	115	Capacitance for Surge	524
Settings	391	Loading	112 to 115	Charging Kva	280
Time Ratings—Grounding Devices	660	Loss Product	102, 103	Choice of Conductors	3
Timer—Ignitron Electric	728	Loss Ratio	102, 103	Circle Diagrams	
Tower Footing Resistance	579	Losses	101 to 103	General Equivalent	277
Tower Top Potential Due to		Magnetizing Inrush Cur-		In Terms of ABCD Constants	278
Lightning	581, 584	rents	126 to 128	Long Lines	275
Transfer Admittance	332	Magnetizing Inrush, Effect on		Short Lines	273
Transformations—in Impedance Form	305	Relaying	353	Clearances	579, 584, 596, 792, 796
Transformations—Ratio and Angular	297	Negative-Sequence Impedance	138	Conductor Spacing	8, 792, 796
Transformer Breaker, Primary		Neutral Insulation	108, 109	Construction Details	
Network Unit	698, 699	Neutral Insulation Levels	109	785 to 789, 792 to 797	
Transformer Capacity, Ratio of Load to	708	No Load Losses	126	Corona	56 to 62
Transformers		Noise	130	Coupling	592
Air Blast	714	Oil Immersed, Self Cooled	105	Curves for Estimating Line	
Air Cooled	106	Overload Capacity	112 to 115	Insulation and Per-	
Ambient Temperature	113	Parallel Operation	130, 131	formance	581, 582
Applied Potential Tests	107, 108	Three Winding	131	Dampers	792
Automatic Loading Control	114, 115	Percent Impedances	98, 144	Design Based Upon Direct	
Autotransformers—See		Phase Shift In	297	Strokes—Chap. 13	578
<i>Autotransformers</i>		Polarity Markings	106, 107	Design for Given Performance	585
Balancing	714	Portable Substation	116	Design—Inherent Protection	579
Banking	683	Power, CSP	630	Determination of Economical	
Capacity Factor	113	Primary Network	696	Voltage and Conductor Size	7
Common Connection Diagrams,		Reactance Tolerances	99	Effect of Transformers on Line	
Equivalent Circuits	799	Regulating, Relaying	353	Performance	288
Compensating	738	Regulating Voltage and Phase-		Equations for Voltages and Currents	
Completely Self Protected		Angle Control	122 to 124	Long Lines	
Construction	115, 116, 630, 637, 638	Regulation	100, 101	265, 266, 275, 278 to 283	
	104, 105	Regulation Chart	100	Short Lines	265, 270, 271, 273

PAGE		PAGE		PAGE
	Transmission Line (continued)		Transmission Line (continued)	
	Equivalent Circuits		Voltage Regulation of	
	ABCD Con-		Long Lines	271, 288
	stants	266 to 268, 270, 278	Short Lines	270, 271, 286
	Equivalent Pi	267, 269, 272	Voltages Due to Lightning	559, 560
	Equivalent T	267	Wave Shape	560
	Long Lines	266, 267	Wave Propagation on, Chap. 15	523
	Short Lines	265, 270	Wood Con-	
	Equivalent Impedances		struction	588, 589, 591, 596, 598
	Equivalent Pi	267 to 269, 272	Transmission System, Mechanical	
	Equivalent T	267, 268	Analogy	439
	Simplified Method	267 to 270	Transpositions	
	Equivalent Pi vs. ABCD	268	Fundamental Frequency Effects	748
	Equivalent Spacing	280	Noise Frequency Effects	778
	Fault Clearing		Traveling Waves	523
	Times	785 to 789, 792 to 797	Applied to 60-Cycle Conditions	540
	Flashover Characteristics of Sus-		Attenuation and Distortion	
	pension Insulators	597	536 to 540
	Footing Resistance	579	Attenuation Empirical Data	538
	Ground Wires	606, 607	Conditions at the Beginning of	
	Impedance Data—(See <i>Aerial</i>		a Parallel	534
	<i>Lines</i>)		Coupling Factor	534
	Impedance Data—		Coupling Factor for Two Ground	
	Typical	279, 280, 395, 396	Wires	535
	Impedance in One Line	25	Current	524
	Increasing Protection Level	585, 586	Depth of Penetration	537
	Inductance for Surge	524	Distortion of	536
	Insulators Required for		Illustrations	523, 526
	Switching Surges	584	In Reverse Direction	525
	Lightning		Junction of Several Lines	528
	Performance	587 to 592, 792 to 797	Line Terminated by a Capacitor	529
	Lightning Protection	578, 579	Line Terminated by an Inductance	
	Lightning Stroke Current		Any Wave Form	528
	Probability Curve	585	Square Topped Wave	528
	Loss		Line Terminated by Network	530
	Long Lines	273, 278	Line Terminated by Resistance	527
	Short Lines	271, 282, 286	Mathematical Expression	525
	Loss Diagram	278	Mechanical Analogy	523
	Lowering Tower-Footing		Mutually Coupled Circuits—	
	Impedance	593	Analytical Representation	532
	Mid-Span Potential Due to		On Parallel Conductors	533, 534
	Lightning	581, 584	Points of Discontinuity	526
	Mid Span Spacings	584	Principle of Superposition	525
	One Line Open	25	Reflections	526
	Permissible Loading	479, 480	Reflections by Lattice Network	530
	Permissible Loading Curve	479, 480	Reflections Due to Shunt Network	530
	Power Equations		Square-Topped	528
	General Equivalent	277	Transmitted and Reflected	530
	In Terms of ABCD Constants	278	Velocity of Propagation	525
	Long Lines	275	Wave in One Conductor with a	
	Short Lines	273	Parallel Conductor Grounded	533
	Vector Equations	273	Trigonometric Function Tables	810
	Probability of Outage	586	Trip-Free Control, Circuit Breakers	377
	Protective Angle	579, 592	Triple Harmonics	
	Quick-Estimating		Power System	772
	Charts 38, 39, 281 to 283, 285, 287		Synchronous Machines	760
	Quick-Estimating Table	7	Transformers	761
	Recent Design		Tripping A-C, for Circuit Breakers	378
	Practice	785 to 789, 792 to 797	Tuning Devices for Power-Line	
	Regulation and Loss Chart	287	Carrier	417 to 420
	Relay Protection of	356	Turbine Generators	
	Series Capacitors	482	Progress in Design	3
	Stability Features	785	Standard 3600-Rpm Condensing	3
	Statistical Data 785 to 789, 792 to 797		Two-Reaction Method	444, 476
	Steady-State Analyzed by		Unbalanced Currents in Cables	84
	Traveling Waves	540	Unbalance Factor	15
	Steel Towers	590, 591	Unbalanced Faults—Use of Symmetri-	
	Surge Impedance	280, 281, 524	cal Components	24, 26
	Surge Impedance		Underground Secondary Network	702
	Loading	280, 281, 479, 480	Ungrounded Systems	
	Switching	387	Application	649 to 651
	Tower Footing Resistance	579	Discussion	643, 644
	Tower Top Potential Due to		Vector	
	Lightning	581, 584	Conjugate of	20
	Transient Stability With Reclosure	492	Operator "a"	13
	Two Lines Open	25	Rotation	13, 14
	Typical Constants 279, 280, 395, 396		Sequence	14
	Typical Fault Clearing		Velocity of Propagation—Traveling	
	Times	785 to 789, 792 to 795	Waves	525
	Typical Impedance		Vertical Networks	713
	Data	279, 280, 395, 396	Vibration Dampers—Typical	
	Use of Protector Tubes (See Also		Practice	792 to 795
	<i>Protector Tubes</i>)	599	Volt-Time Curves	614
	Vibration Dampers	792		
			Voltage	
			Base	295
			Choice of	6
			Drop Due to Self and Mutual	
			Impedances	16
			Drop, Examples	313, 316, 319
			Drop in	
			Distribution Feeders	681
			Distribution Transformers	683
			Maximum During Fault Conditions	626
			Recovery Theory	504, 505
			Regulation	696
			Surge	523
			Theory of Recovery	504, 505
			Trend	6
			Unbalanced Three Phase	14, 15
			Voltage-Regulator	
			Approximate Impedance Data	395
			Automatic Control Unit	226
			B-J	220 to 222
			Cross-Current Compensation	220, 222
			Current-Limiting Device	224, 231
			Damping	221, 222
			Damping Transformer	220
			Direct-Acting Rheostatic	217, 220
			Electronic	232
			Field Forcing	221, 222
			Flicker	738
			For Machines	455, 479, 487 to 489
			Hunting	221, 222
			Impedance Type	224, 225
			Indirect Acting Exciter	
			Rheostatic	220 to 222
			Line-Drop Compensation	223
			Manual Control Unit	228
			Minimum Excitation Unit	227
			Sensitivity	217
			Silverstat	218 to 220
			Static Potential Unit	225
			Synchronous Condenser	223, 224
			Types	217
			Voltage Adjusting Unit	226
			Voltage Regulation	
			Tap Changing Under Load	121, 122
			Water-Cooled Transformers	106, 133
			Water Power	4
			Wave Front—Effect on Attenuation	540
			Wave Propagation on Transmission	
			Lines—Chap. 15	523
			Wave Shape	
			Capacitors	252 to 254, 761
			D-C Machines	761, 772
			Deviation Factor	760
			Filters, Effect of	775
			Guarantees	760
			Induction Motors	761
			Inverters	766
			I.T. Factors	758, 772
			K.V.T. Factors	758, 770, 772
			Lighting Circuits	770
			Lightning Discharge Currents	570, 571
			Power-System Survey	771, 772
			Rectifiers	766
			Synchronous Machines	759, 761, 772
			System	771, 772
			T.I.F. Factors	757, 760, 771, 772
			Transformers	761
			Wave Traps	766, 772 to 776
			Welders—Various Types	727
			Wood—Flashover Kv	598
			Wood Pole Structures	596, 598
			Zero Sequence	
			Capacitive Coupling in	
			Transformers	662
			Current in a Delta Winding	19
			Isolating Device	653
			Vectors	14
			Voltages of Ungrounded Systems	751
			Zero-Sequence Impedance	
			Aerial Lines	28, 41 to 47, 396
			Cable	74 to 77, 79 to 94
			Synchronous Machines	520
			Transformers	138, 139, 799 to 808